

**VALEO**

**INVESTOR DAY**

— Paris 2019 —



# LEADERSHIP IN ELECTRIFICATION

## DRIVING GREENER MOBILITY



SMART TECHNOLOGY FOR SMARTER MOBILITY



**XAVIER DUPONT**

POWERTRAIN SYSTEMS  
BUSINESS GROUP PRESIDENT

**MICHEL FORISSIER**

POWERTRAIN SYSTEMS  
CHIEF TECHNOLOGICAL OFFICER



SMART TECHNOLOGY FOR SMARTER MOBILITY

# VALEO POWERTRAIN SYSTEMS



# OUR MISSION

**GREENER**  
MOBILITY

# ELECTRIFICATION IS A FUNDAMENTAL TECHNOLOGICAL SHIFT

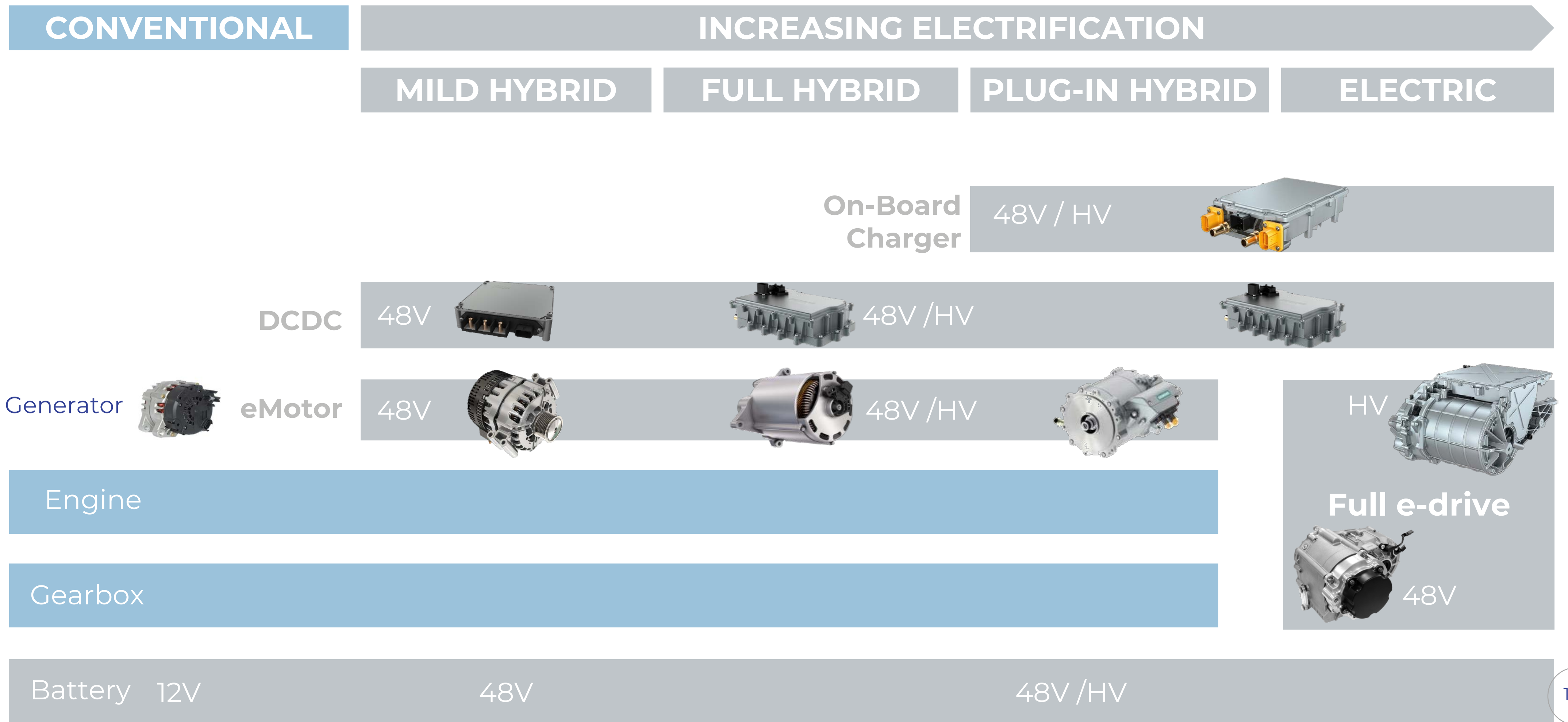

# ELECTRIFICATION IS A FUNDAMENTAL TECHNOLOGICAL SHIFT

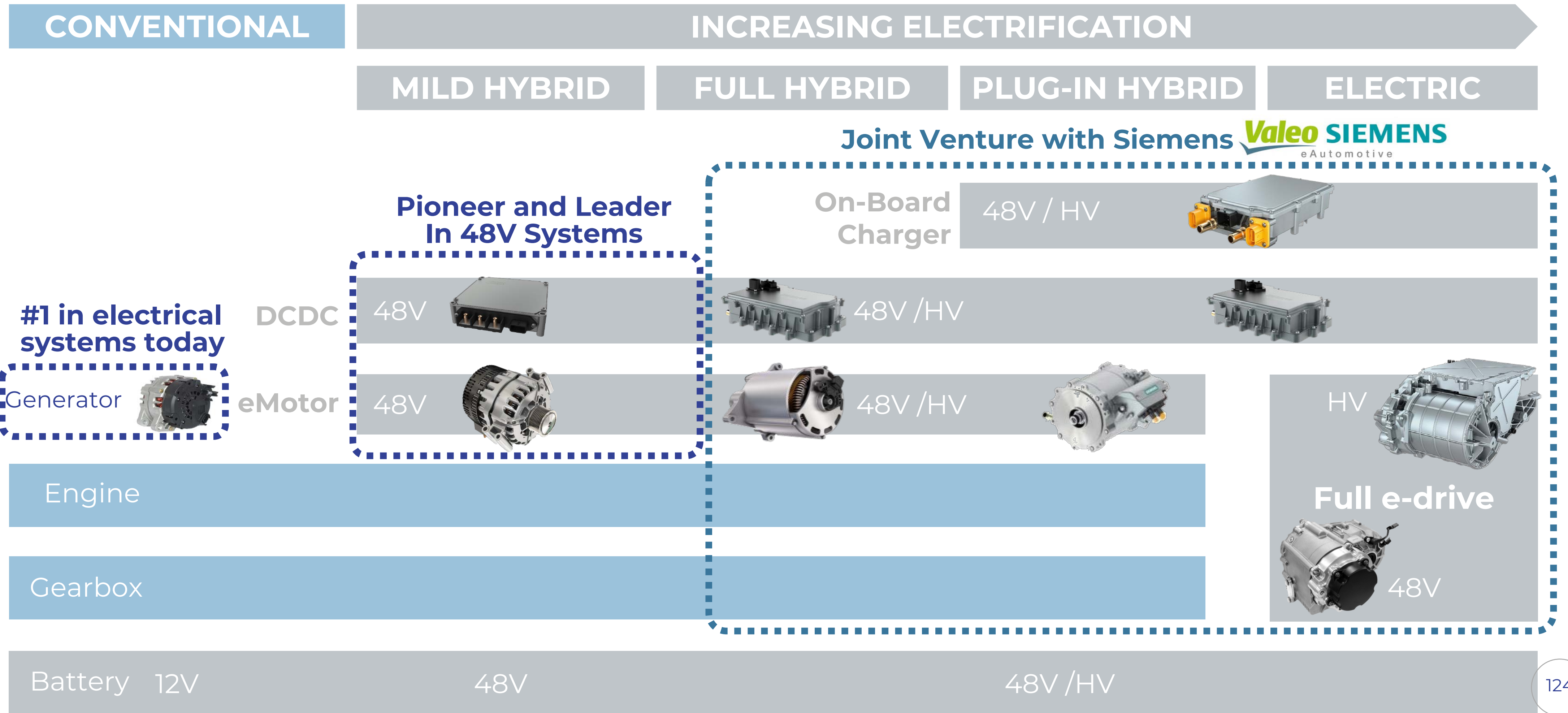

# ELECTRIFICATION IS NOT AN OPTION

## REASON #1 = CO<sub>2</sub> REGULATION

EU CO<sub>2</sub> EMISSIONS REDUCTION POLICY (g/km)

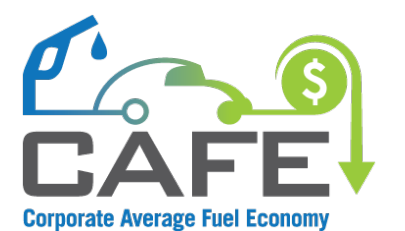
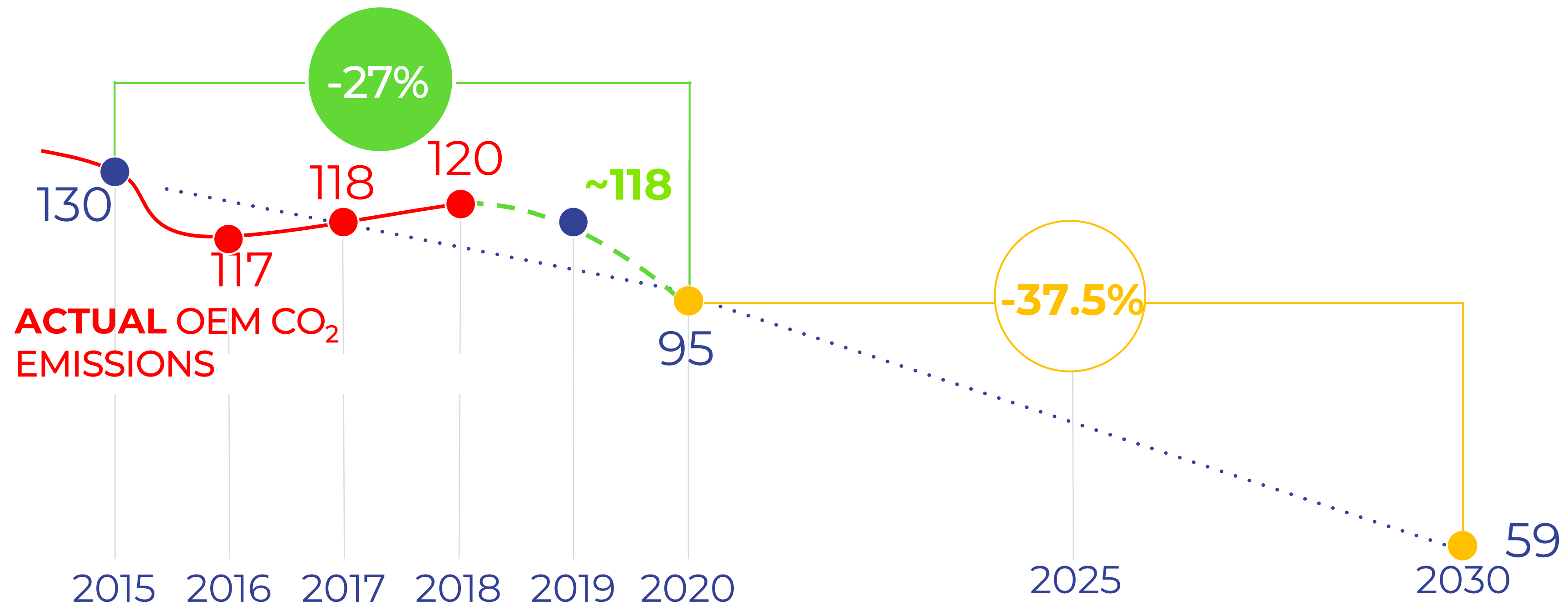



# ELECTRIFICATION IS NOT AN OPTION

## REASON #1 = CO<sub>2</sub> REGULATION

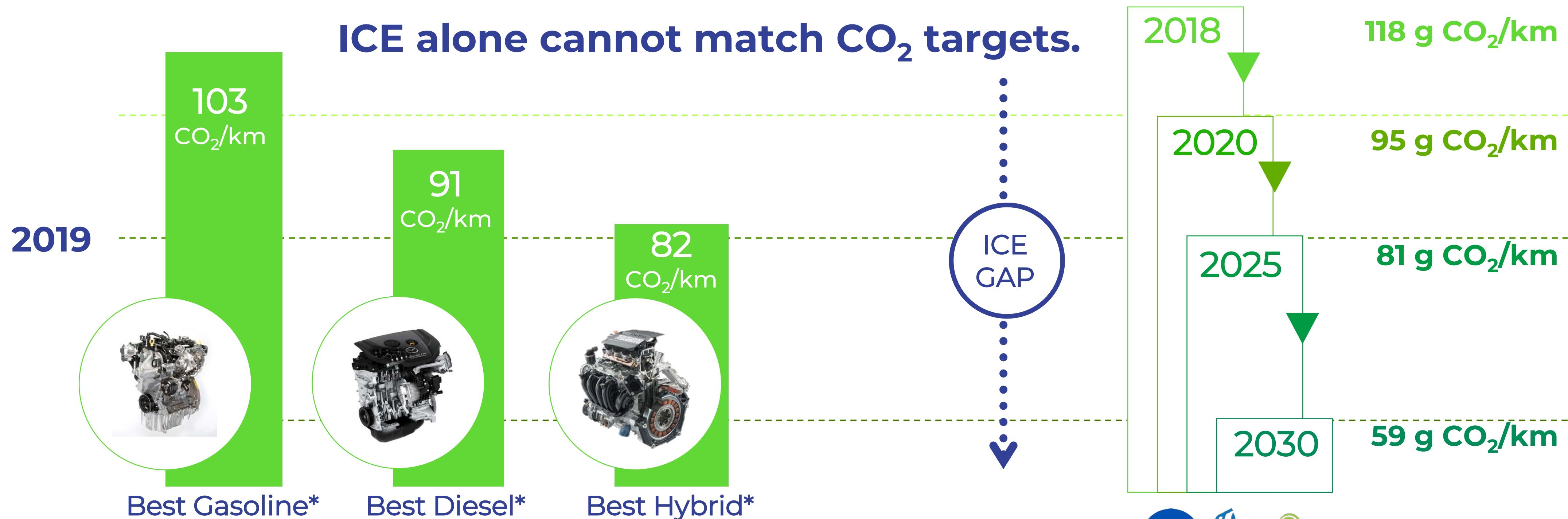

(\*) : Best performer in C-segment

# ELECTRIFICATION IS NOT AN OPTION

## REASON #2 = CITIES BAN DIESEL



# ELECTRIFICATION IS NOT AN OPTION

## REASON #3 = Countries Ban all Thermal engines

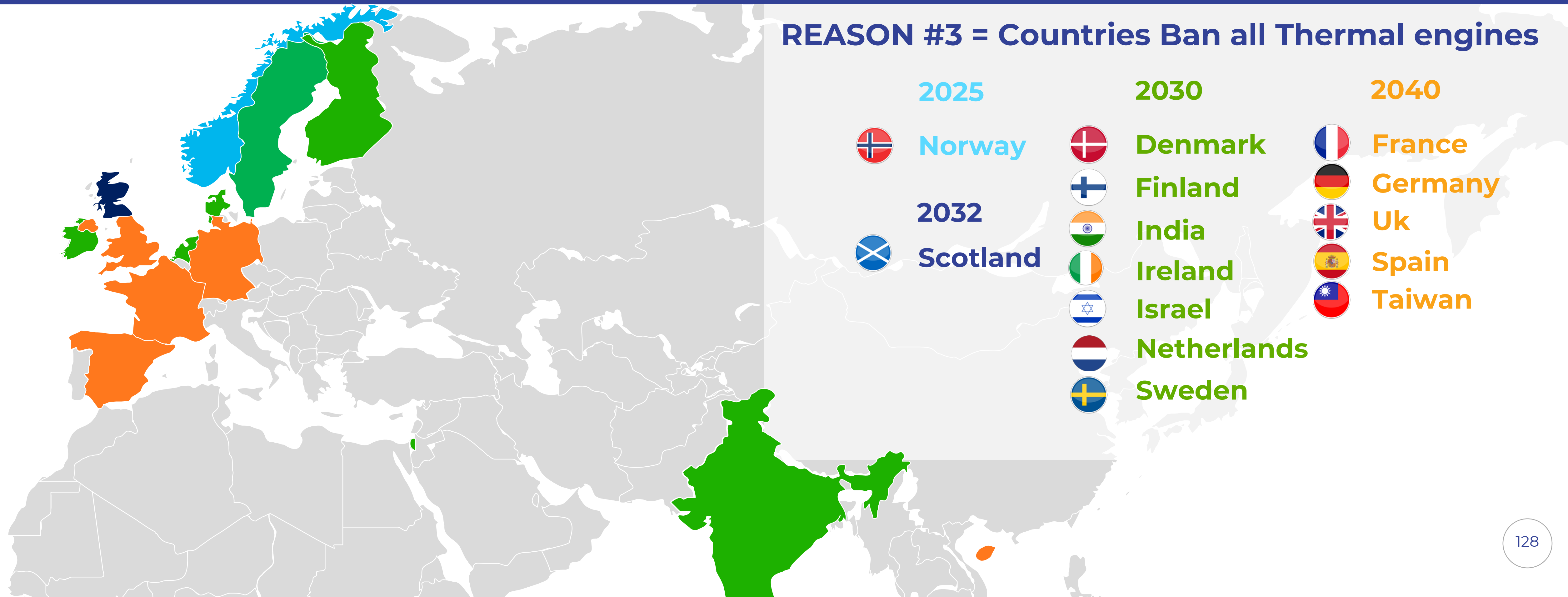

# ELECTRIFICATION IS NOT AN OPTION

## REASON #4 = DIESEL DECLINE

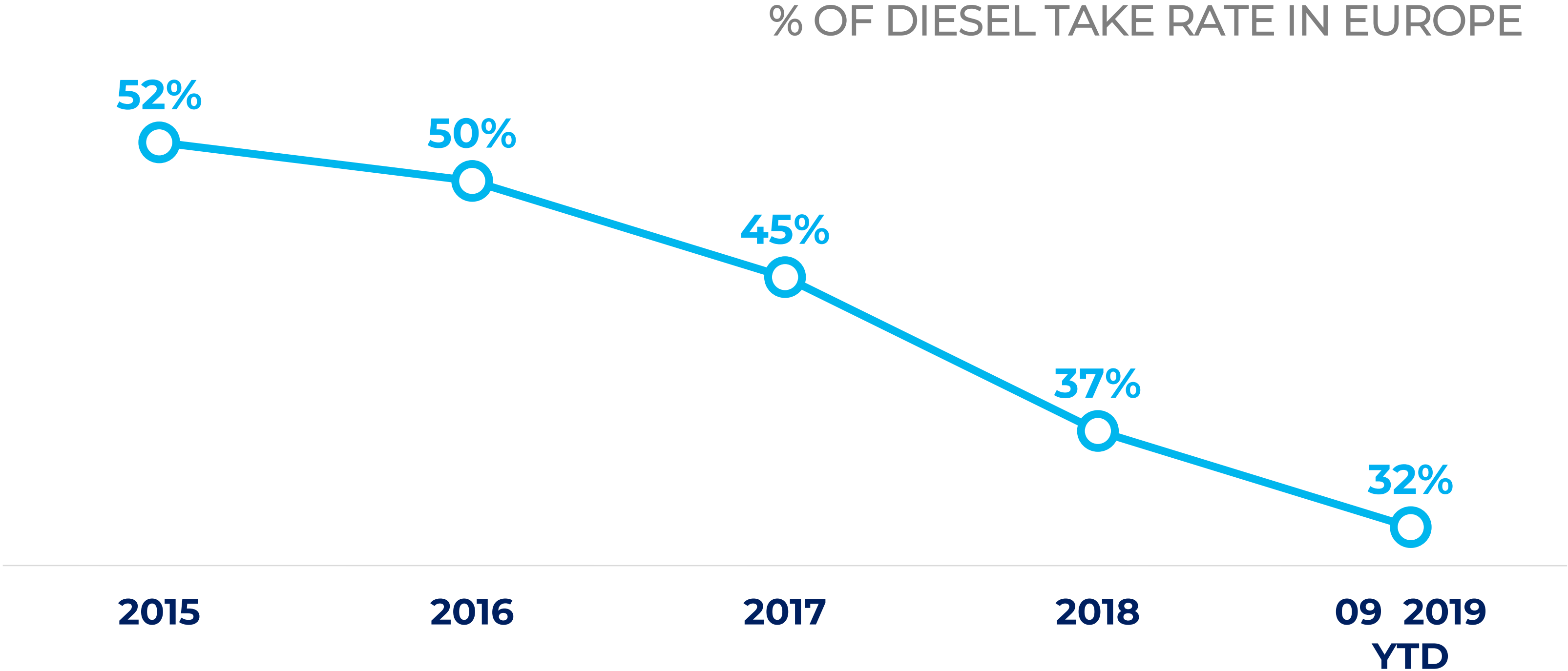

# ELECTRIFICATION IS NOT AN OPTION

## REASON #5 = CHINA

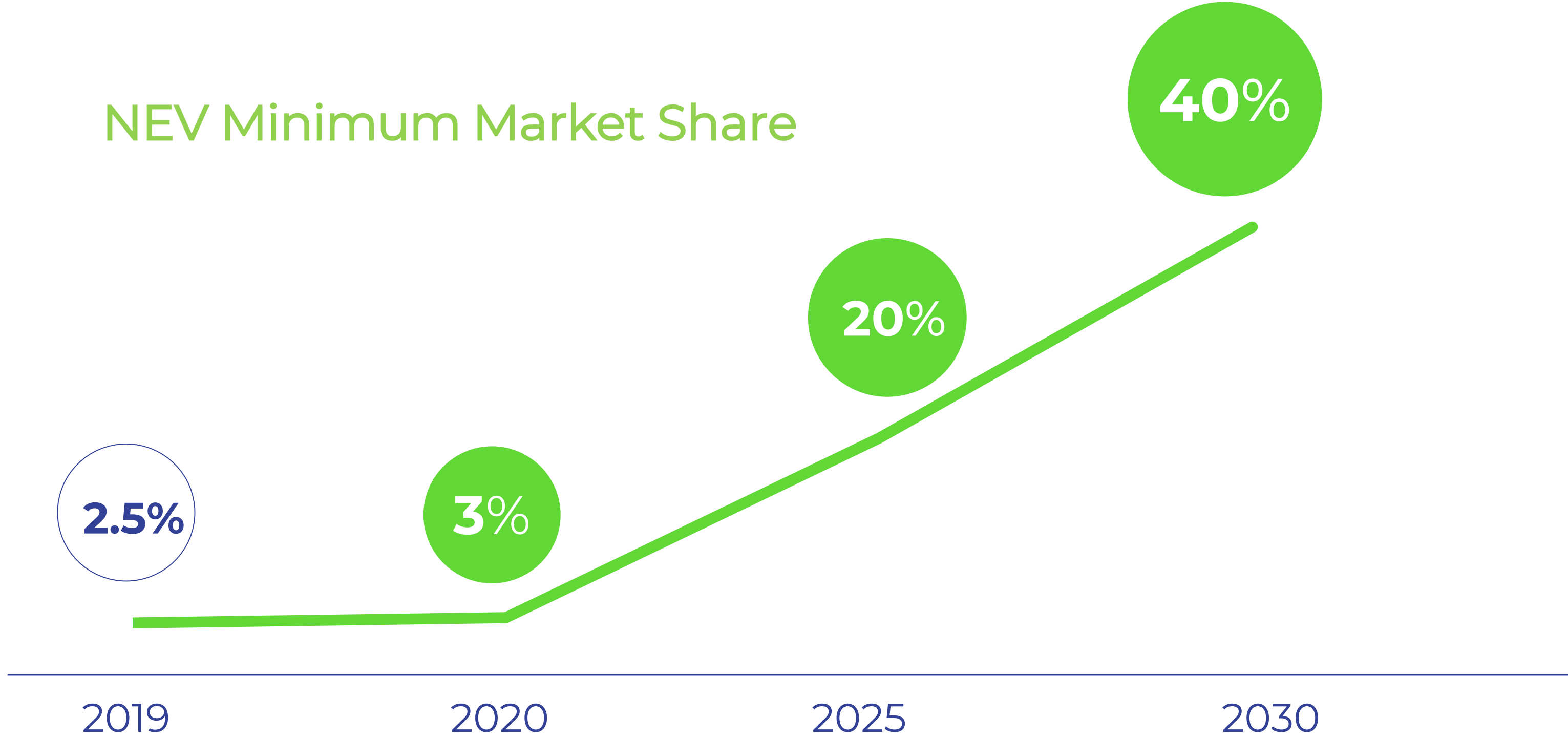

# ELECTRIFICATION IS NOT AN OPTION

## REASON #6 = A NEW USER EXPERIENCE

**ZERO EMISSIONS**  
(No CO<sub>2</sub>, CO, NO<sub>3</sub>, HC,  
particulates...)



**LUDICROUS  
ACCELERATION**



**NO NOISE  
NO VIBRATIONS**



**... AND MOREOVER  
COOL DRIVING**



# ELECTRIFICATION IS NOT AN OPTION

REASON #7 = ELECTRIC CAR OFFER IS TAKING OFF ... NOW

CUMULATED NUMBER OF  
NEW ELECTRIC CAR SILHOUETTES

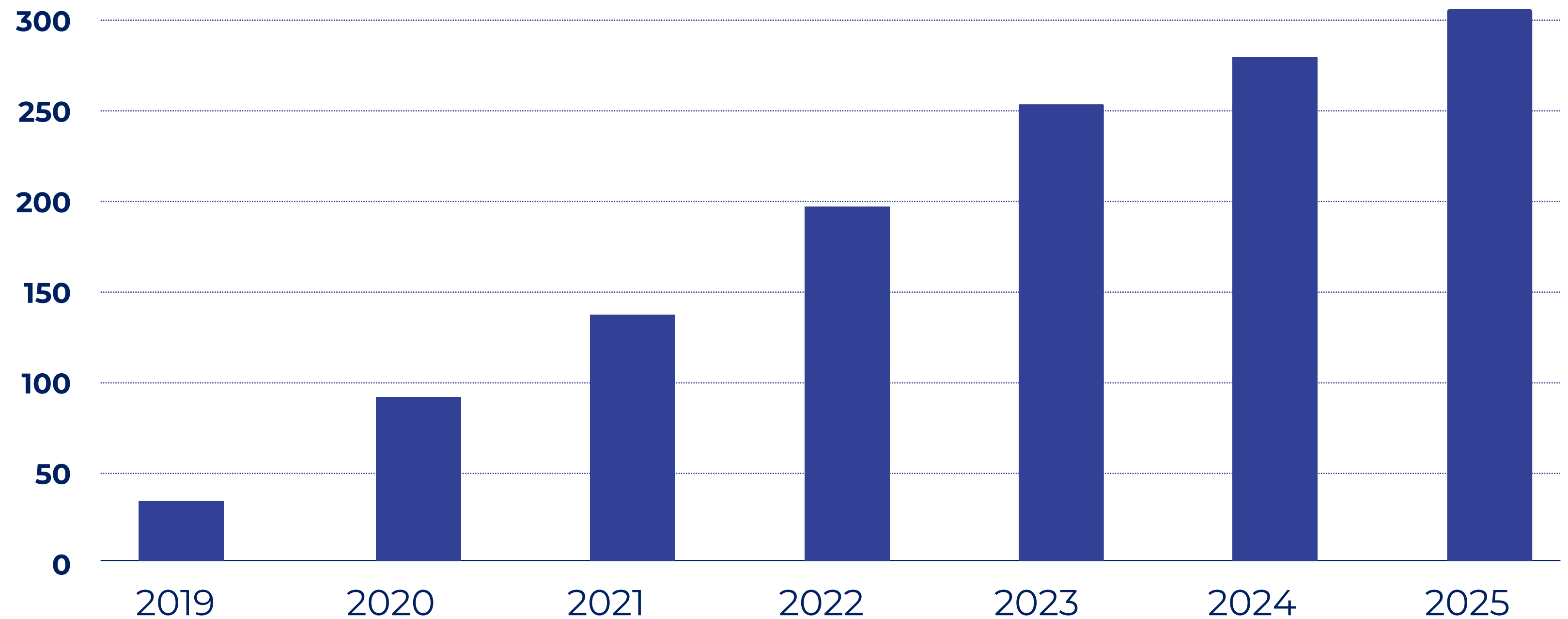

# ELECTRIFICATION

**GROWTH** IS THERE



# ELECTRIFICATION: GROWTH IS THERE FOR BOTH 48V AND HIGH VOLTAGE SOLUTIONS

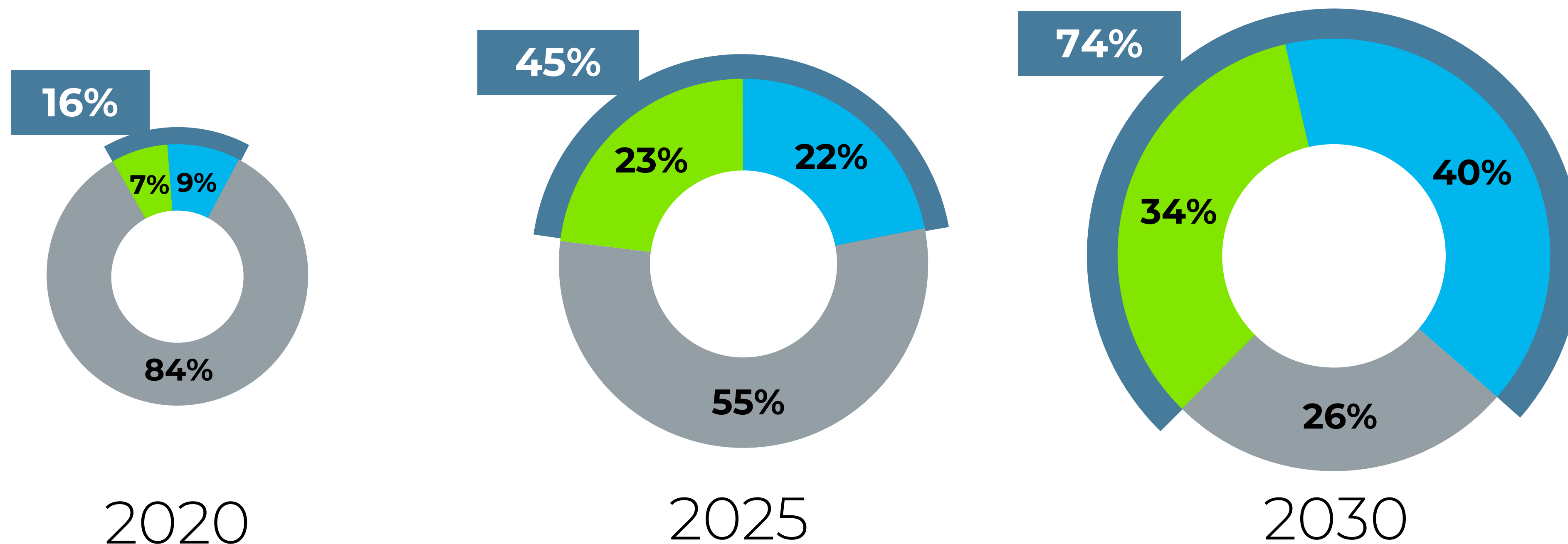

\* Incl. 48V and 12V+12V

\*\* Incl. HV BEV, PHEV, FCEV & FHEV  
Passenger Car & Light Commercial vehicles

- 48V ELECTRIFICATION\*
- HIGH VOLTAGE ELECTRIFICATION\*\*
- INTERNAL COMBUSTION ENGINE ONLY

# ELECTRIFICATION: GROWTH IS THERE

**SMART MOBILITY  
IS GOING  
ALL-ELECTRIC**

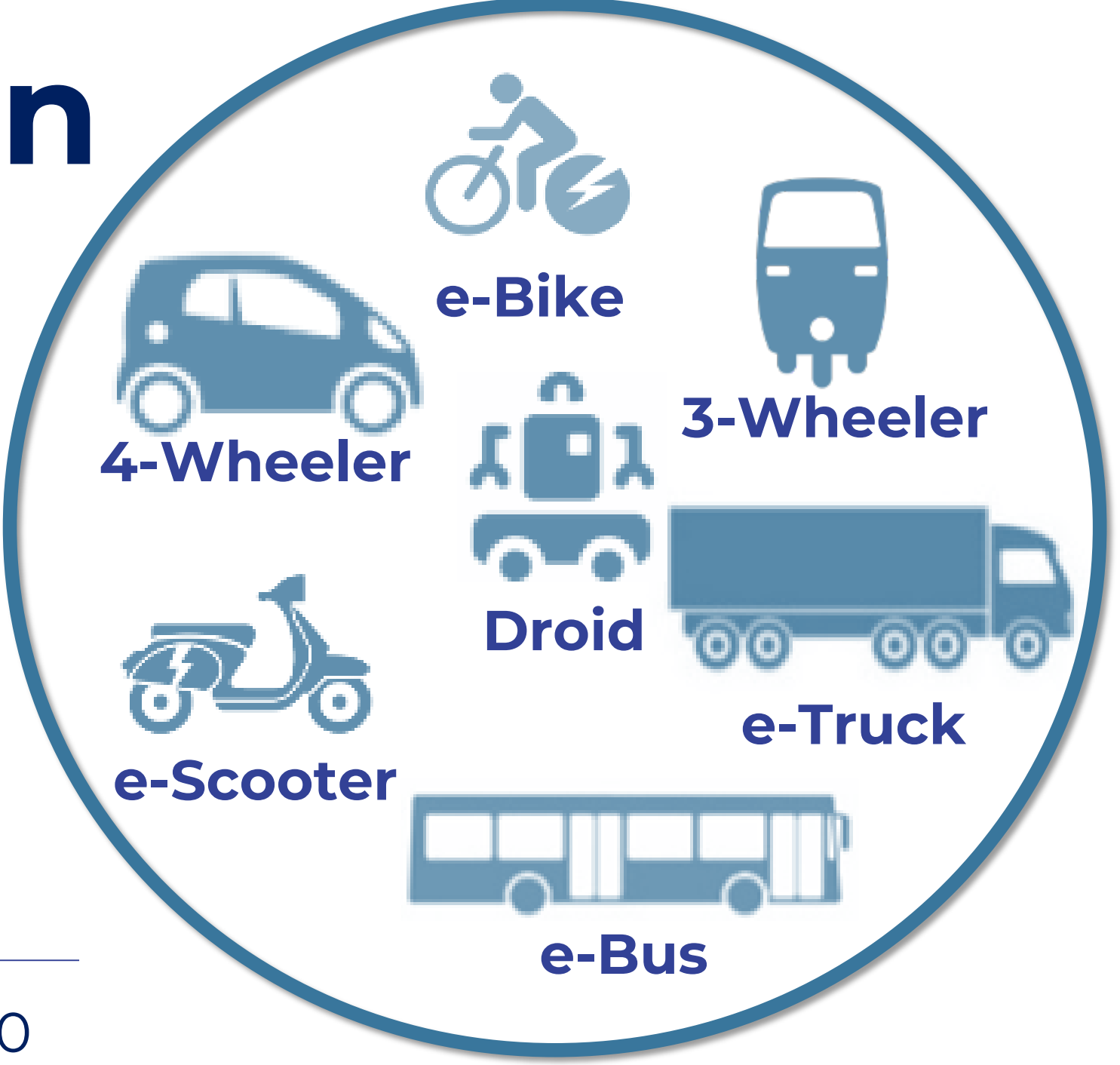

Smart e-Mobility Market

# ELECTRIFICATION: GROWTH IS THERE

2030  
ELECTRIFICATION  
MARKET\*

€131Bn

SMART e-MOBILITY  
(Mainly 48V)

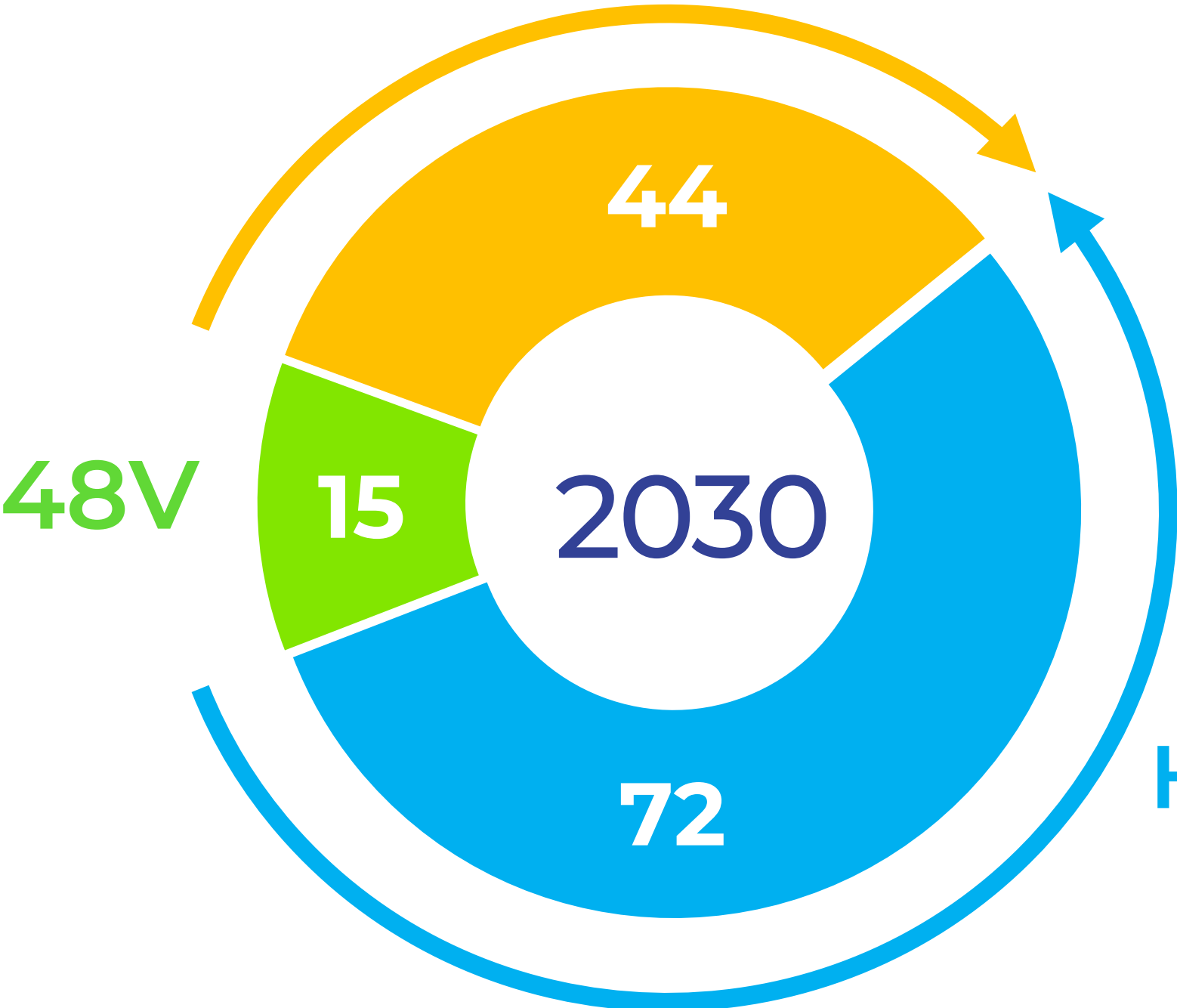

HIGH VOLTAGE  
**Valeo** SIEMENS  
eAutomotive

\* Valeo addressable market, excluding batteries

# 48V ELECTRIFICATION: GROWTH IS THERE

2030  
48V ELECTRIFICATION  
MARKET

€15Bn



MAX  
Content  
per car

x2

€7.5Bn ORDER INTAKE

# WE HAVE INVENTED AND PIONEERED THE 48V ELECTRIC MARKET

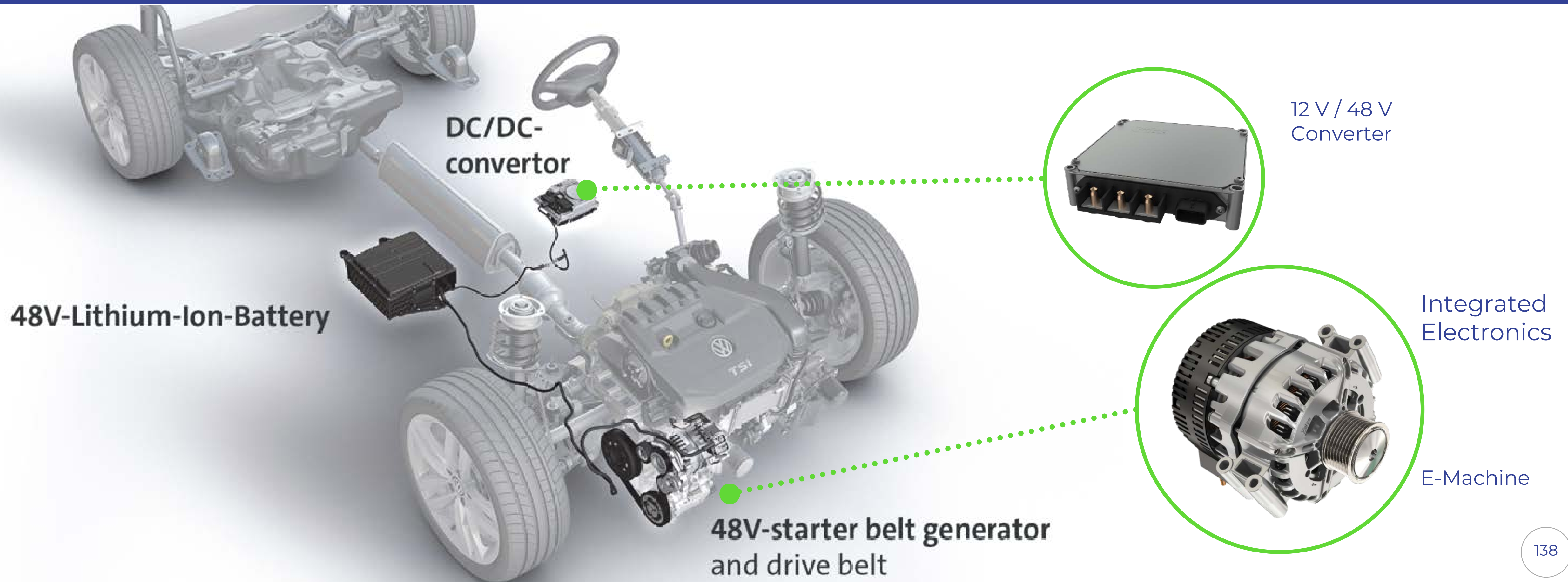

**WE HAVE BUILT**

**48V**

TECHNOLOGICAL  
PLATFORMS

# 48V e-MACHINE PLATFORM



**>300 000**  
Machines shipped

**>40%**  
Market Share in 2022

**Key enabler**  
For CO<sub>2</sub> reduction

# 48V e-MACHINE A COMPLEX ELECTRONIC SYSTEM





# NEXT GENERATIONS ARE BASED ON THE SAME PLATFORM

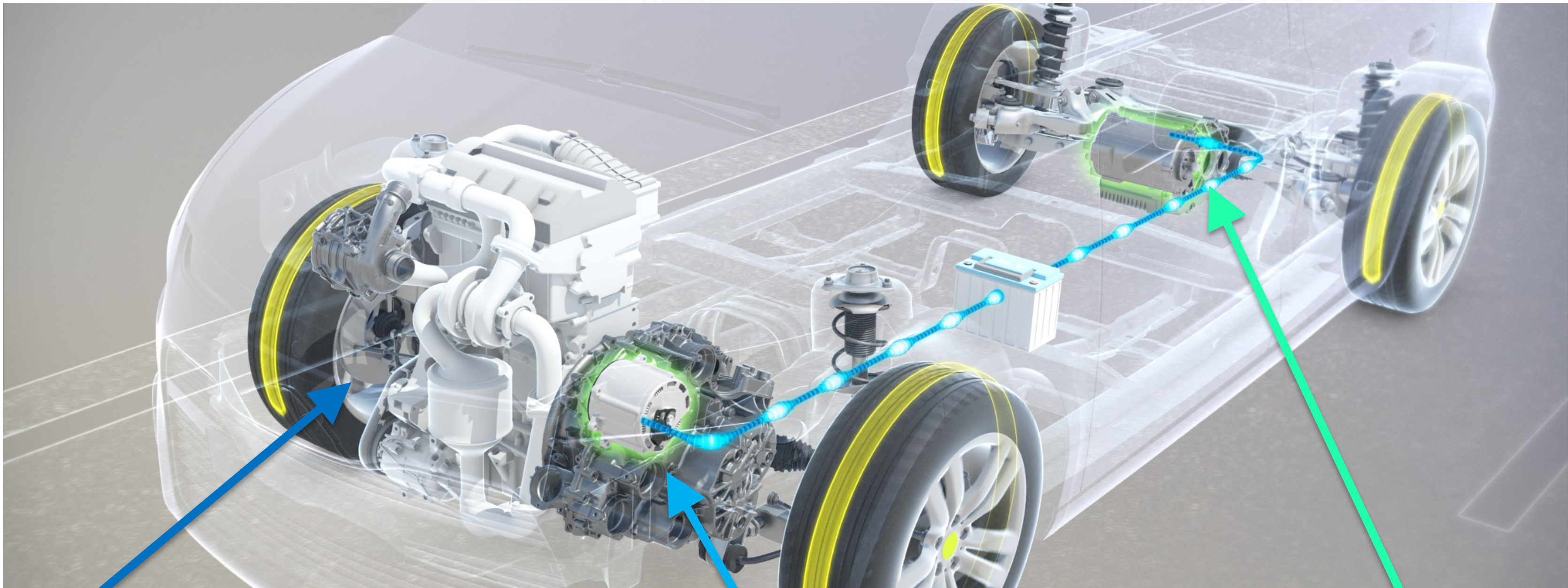

**Starter Generator  
4-12 kW**

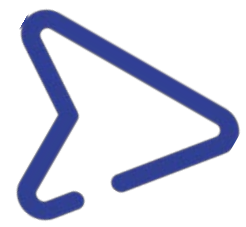

**Electric motor  
15 kW**

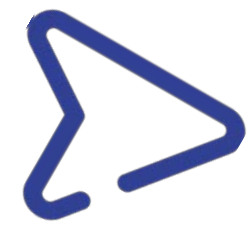

**Full Electric rear axle  
25 kW**

# 48V DC/DC PLATFORM



**10 000 000 units**  
Already booked

**50%**  
Market Share in China

**All 48V cars**  
Need one

# 48V ELECTRIFICATION: GROWTH IS THERE

2020 - 2022



Valeo 48V  
inside 60 vehicles

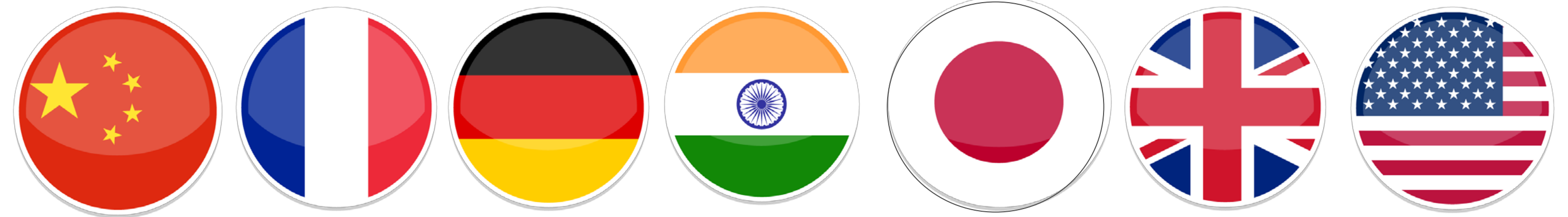

# 48V ELECTRIFICATION: GROWTH IS THERE

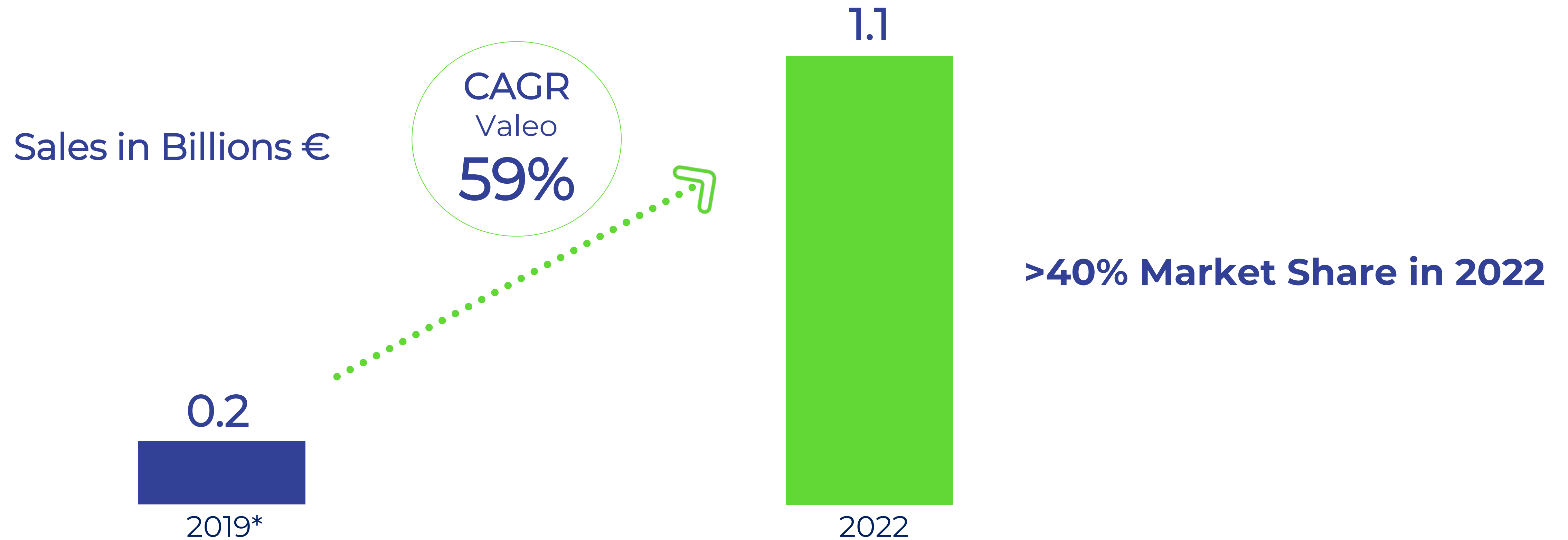

\*Estimated 2019.

**WE HAVE BUILT SUCCESSFUL  
TECHNOLOGICAL PLATFORMS**

**WE LEVERAGE**

OUR TECHNOLOGICAL PLATFORMS  
WITH NEW VALUE SPACES



January 7-10, 2020

# SMART e-MOBILITY IS MORE THAN CARS



# SMART e-MOBILITY BASED ON 48V PLATFORM



# SMART e-MOBILITY: GROWTH IS THERE

2030  
SMART e-MOBILITY  
MARKET

€44Bn



MAX  
Content  
per  
vehicle

1.000€

**ALREADY SEVERAL AWARDS**



# WE ARE ALREADY ENTERING SMART e-MOBILITY MARKET

European  
OEM



SOP

Q1 2020

Indian  
OEM



SOP

Q2 2020

European  
OEM



SOP

Q3 2020



Expected in 2021

# HIGH VOLTAGE ELECTRIFICATION: GROWTH IS THERE

2030  
HV ELECTRIFICATION  
MARKET

€72Bn

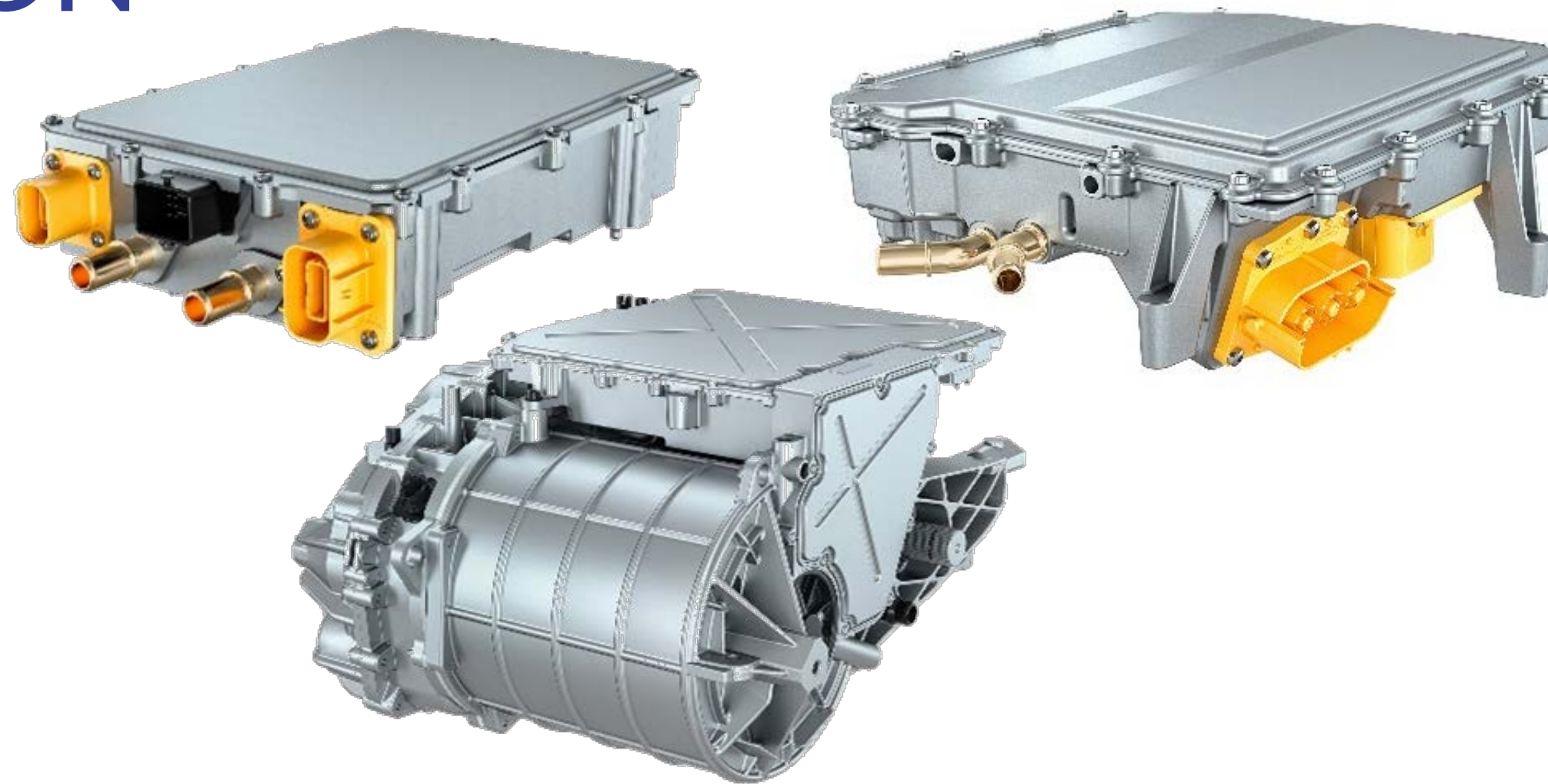

MAX  
Content  
per car

x9

€11Bn ORDER INTAKE

**VALEO SIEMENS e-AUTOMOTIVE  
HAS BUILT**

**HIGH VOLTAGE**  
TECHNOLOGICAL  
PLATFORMS

# A STRONG INVESTMENT IN DEVELOPMENT

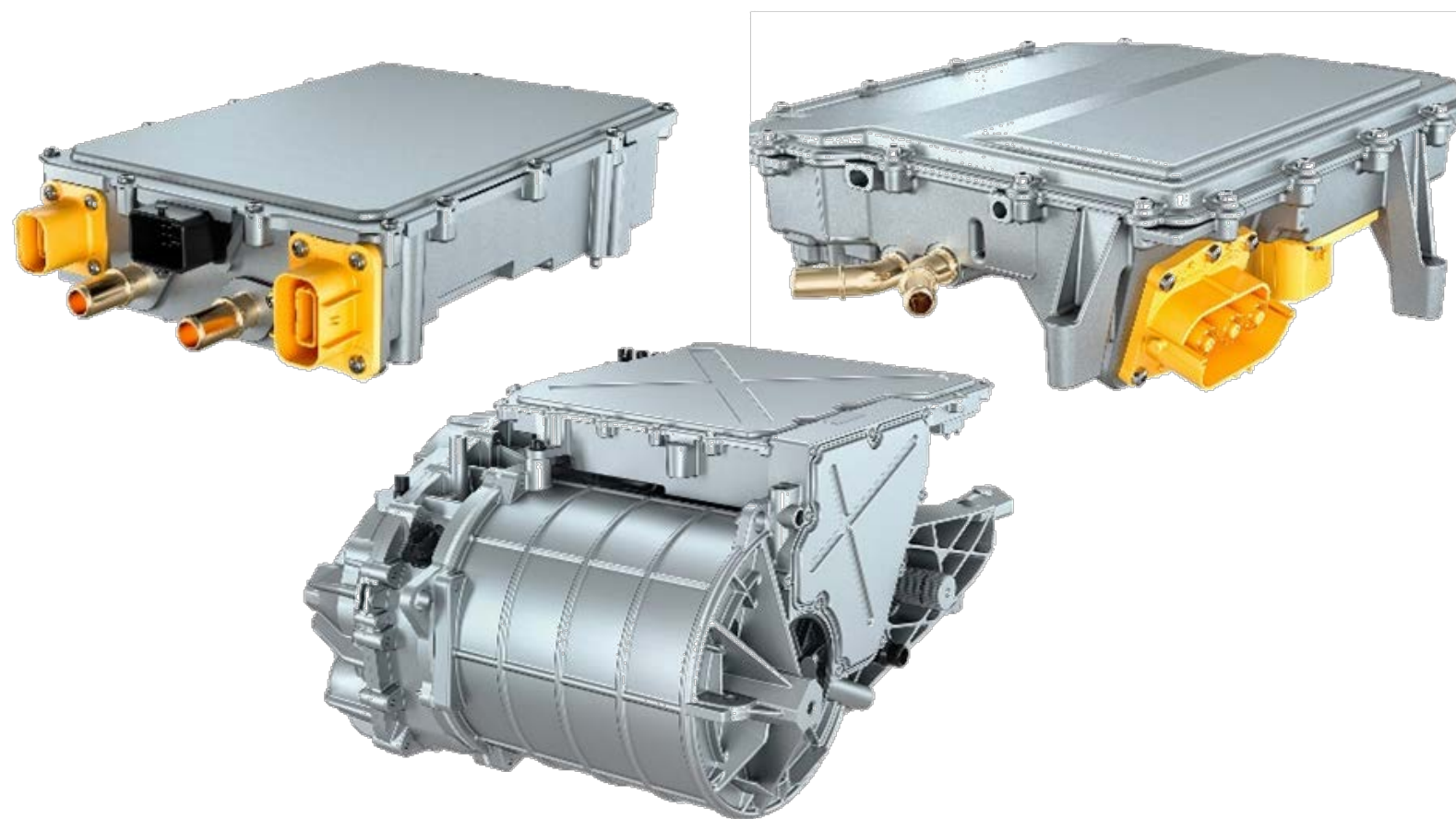

**2017 → 2020**  
Development  
of new platforms

**Best products  
on the market**

**More than  
2000 engineers**

**Unique  
test equipment**

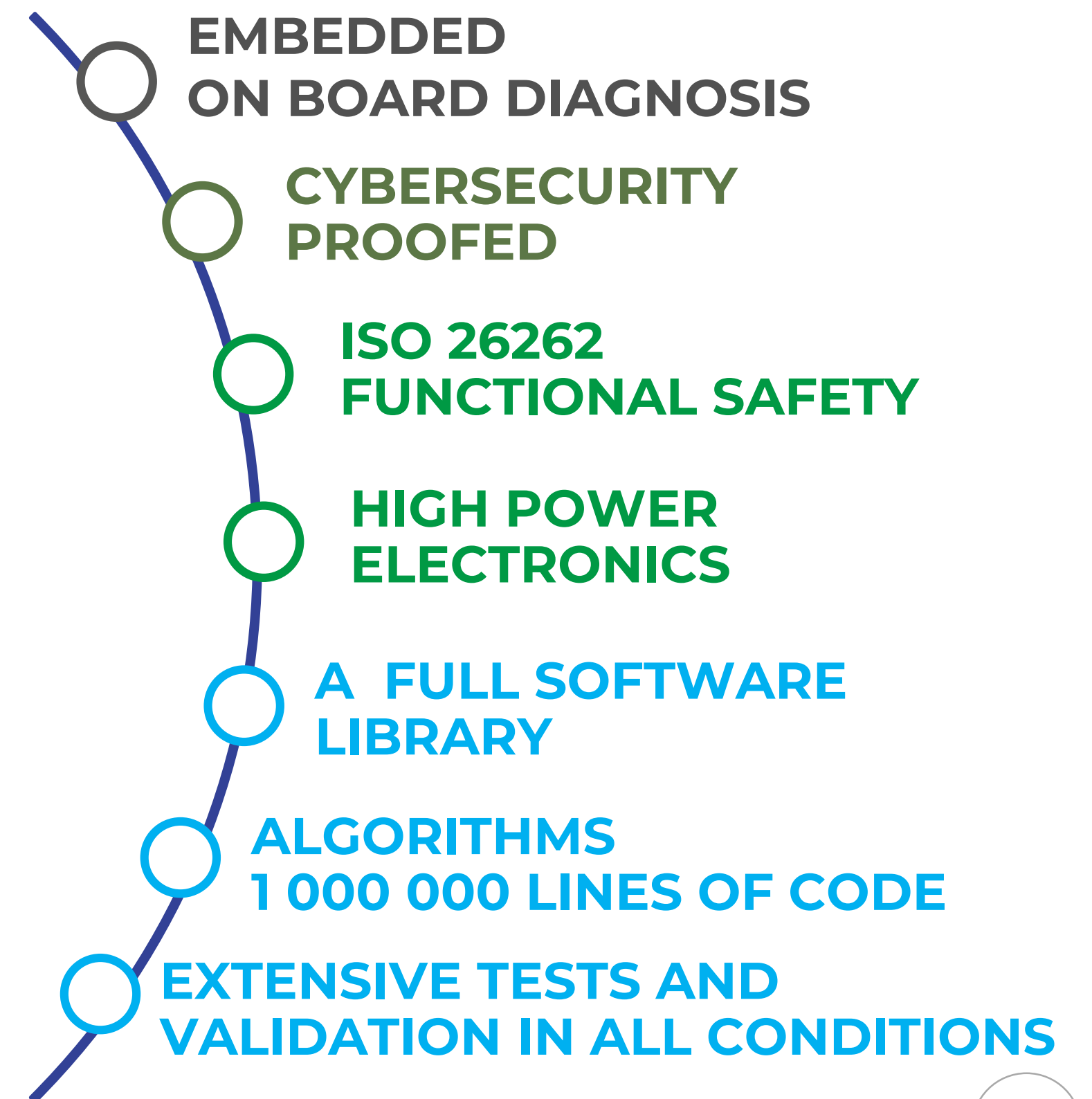

# HIGH VOLTAGE INVERTER PLATFORM



**€4.4Bn**  
Order Intake

**51%**  
Sales CAGR 18-24

**The BRAIN**  
Of the electric car

# HIGH VOLTAGE ON-BOARD CHARGER PLATFORM



**9 customers**  
already trust us

**3 to 22 kW**  
Charging Power

**Vehicle-to-Grid**  
For 2022

# HIGH VOLTAGE e-DRIVE PLATFORM



**60 to 340 kW**

Peak Power

**Full propulsion system**

Motor + Inverter + Transmission

**Up to 4 000€**

Per electric car

# THE INVESTMENT IN SOFTWARE ALLOWS COST REDUCTION

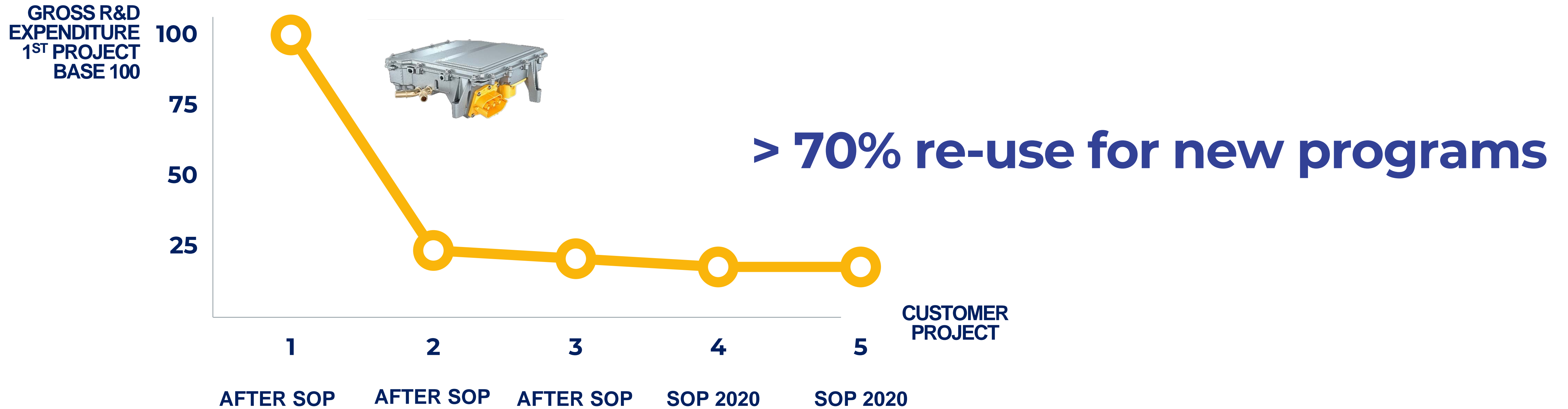

**1 000 000**  
Lines of Code

**> 1 000**  
Software engineers

**Fully configurable**  
Software architecture



# UNIQUE TEST AND VALIDATION CAPABILITIES



**154**

Test beds in parallel

**250**

Vehicles in test  
Including Summer and Winter tests

**Zero Defect**

On functional tests

# HIGH VOLTAGE ELECTRIFICATION: GROWTH IS THERE



Sales  
in Billions €



CAGR  
VSeA  
**67%**

CAGR  
Market  
**18%**



> 2 Bn€ in 2024

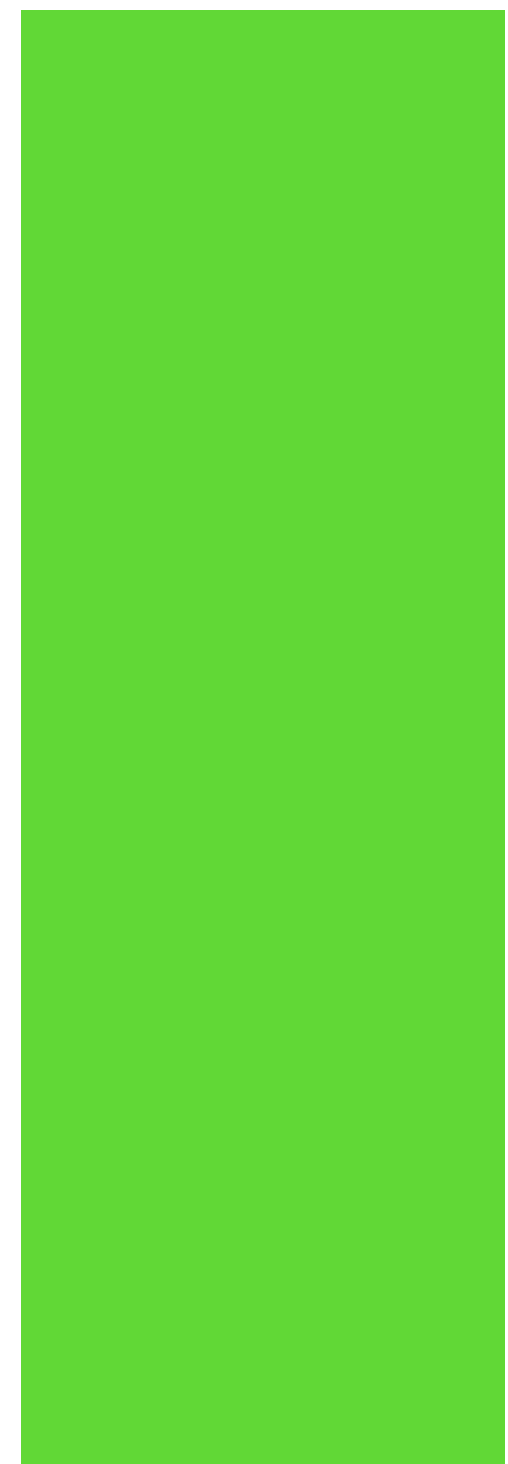

**We are outperforming  
the market by a factor of 3**

# VALEO-SIEMENS IS ACCELERATING



Launches on  
**90** vehicles  
up to **2022**



Volvo V60

2012



BMW i3

2013

2014



Renault ZOE



Volvo XC90

2015



Chevrolet Malibu



Renault Kangoo ZE

2016



BMW 3.30e



Smart For2



Smart For4



2017



Renault Master ZE



BMW 5.30e



LEV TX5



GAC Trumpchi GE3



BAIC EU400



Cadillac XT5



GMC Sierra  
Chevrolet Silverado

2018



eGO Life



Volvo XC60



Volvo S90



Volvo V90

2019



DS7 Crossback e-tense



Peugeot 3008



Opel GrandLand X



BAIC C10



Tata Nexon



Renault Clio



Land Rover Discovery



Renault ZOE2



Renault Captur

2020 and Beyond



VW ID3



And 60 more to come

2020 and Beyond

# VALEO-SIEMENS SUCCESS IS ALREADY VISIBLE TODAY OUTSIDE



**Volvo S90**



**Land Rover Defender**



**New Smart**



**New VW ID3**



**New Renault ZOE**

**Renault Master**



**BMW 330e**



**New DS7 E-TENSE**

# WE HAVE CREATED A LEADER IN ELECTRIFICATION

## Order Intake to date

Source: Public announcement & Valeo estimates

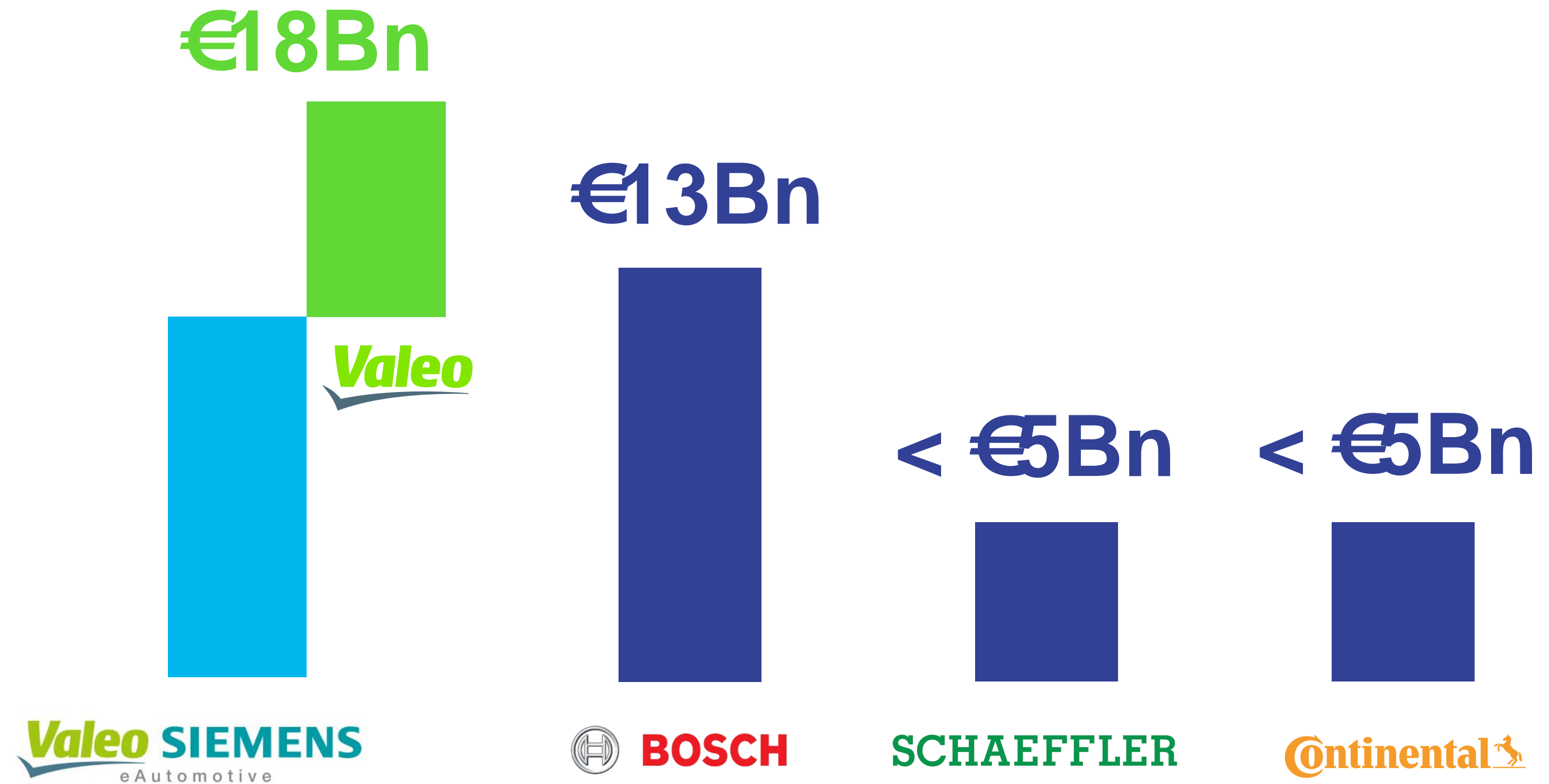

**1 of every 3**  
new car worldwide has  
a Valeo electric machine

**69%**  
Sales CAGR  
2018-2022

**VALEO**

**INVESTOR DAY**

Paris **2019**



**LEADERSHIP IN ADAS**  
DRIVING SAFER AND  
SMARTER MOBILITY



SMART TECHNOLOGY FOR SMARTER MOBILITY



**MARC VRECKO**

COMFORT & DRIVING ASSISTANCE SYSTEMS  
BUSINESS GROUP PRESIDENT

**JOACHIM MATHES**

COMFORT & DRIVING ASSISTANCE SYSTEMS  
CHIEF TECHNOLOGICAL OFFICER



SMART TECHNOLOGY FOR SMARTER MOBILITY



# OUR MISSION

**SAFER**  
&  
**SMARTER**  
**MOBILITY**

## TOWARDS A SAFER MOBILITY

**1.35** million people die  
**in traffic accidents every year,**  
as if an Airbus A320 with 150  
people on board was crashing  
every hour of every day, every  
month in the year

J. KRAFCIK (Waymo CEO)



# ADAS & AD

**WHAT** DO WE MEAN?



# SAFER MOBILITY WILL BE DRIVING ADAS MARKET GROWTH

DRIVERLESS



AUTOMATED DRIVING



DRIVER SUPPORT



ACTIVE SAFETY

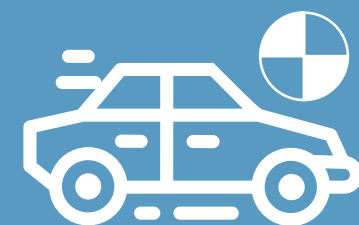

Market Share in Value

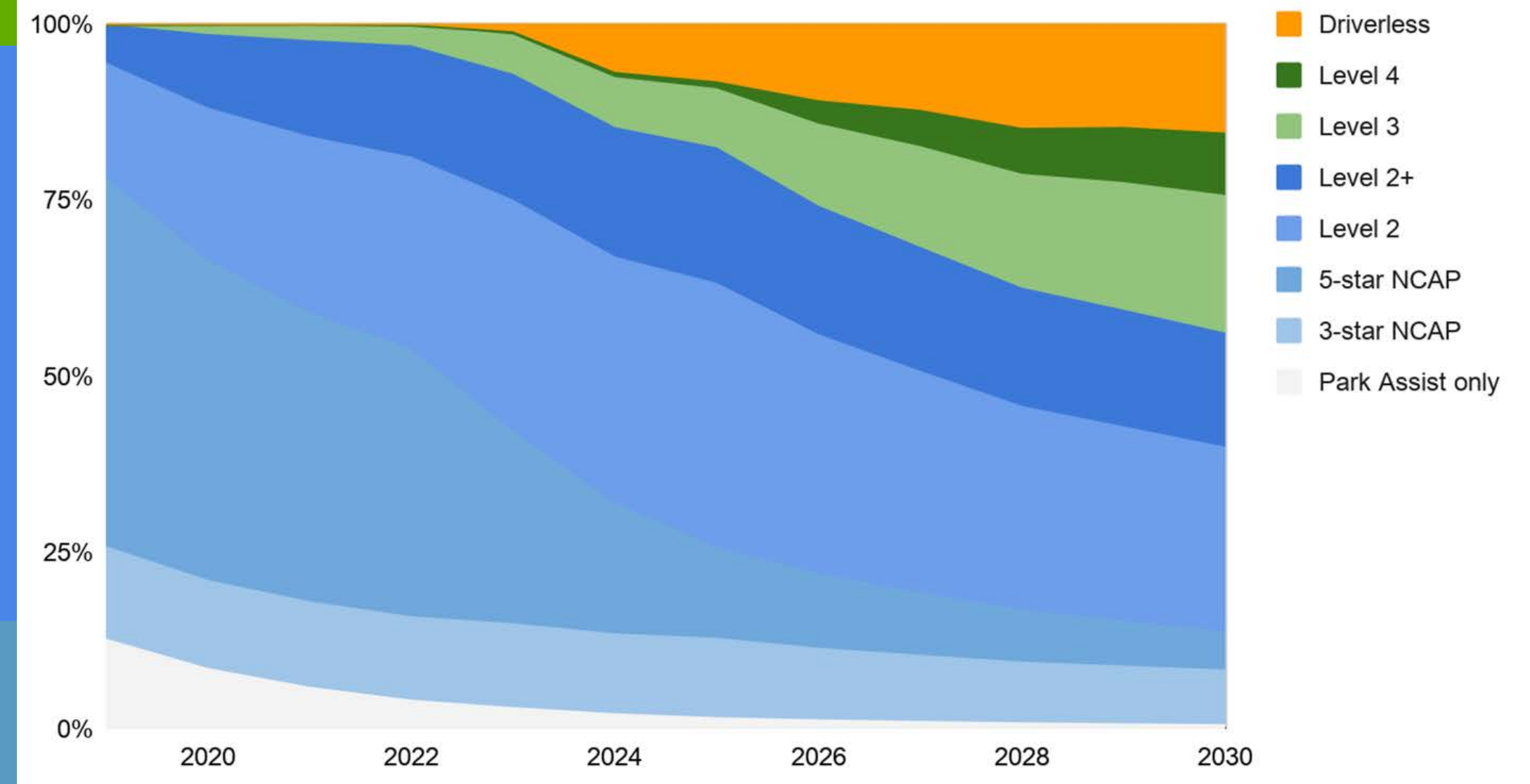

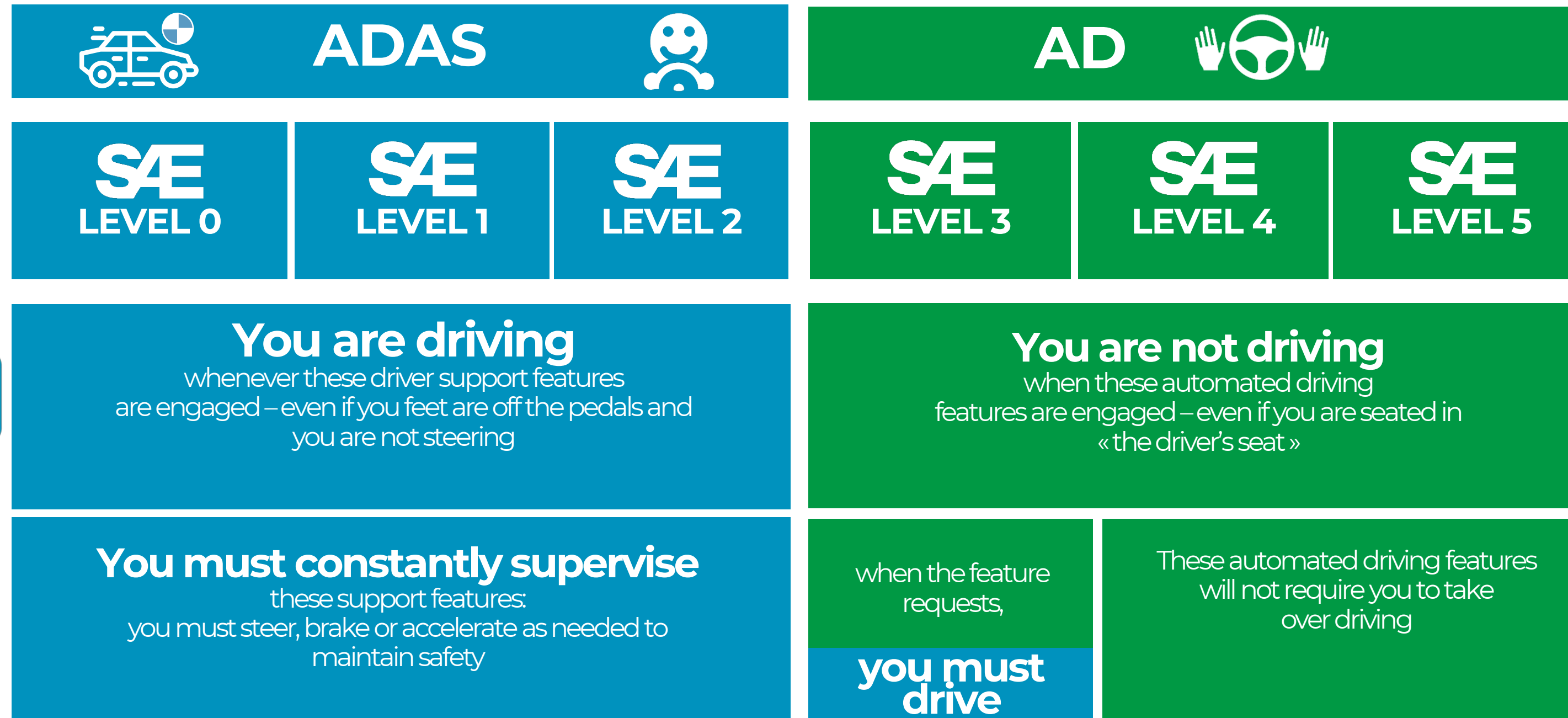

**Driver is responsible** 

**Liability passes to OEM** 

# SAFER MOBILITY WILL BE DRIVING ADAS MARKET GROWTH

Driverless 

These are driver support features

These are automated driving features

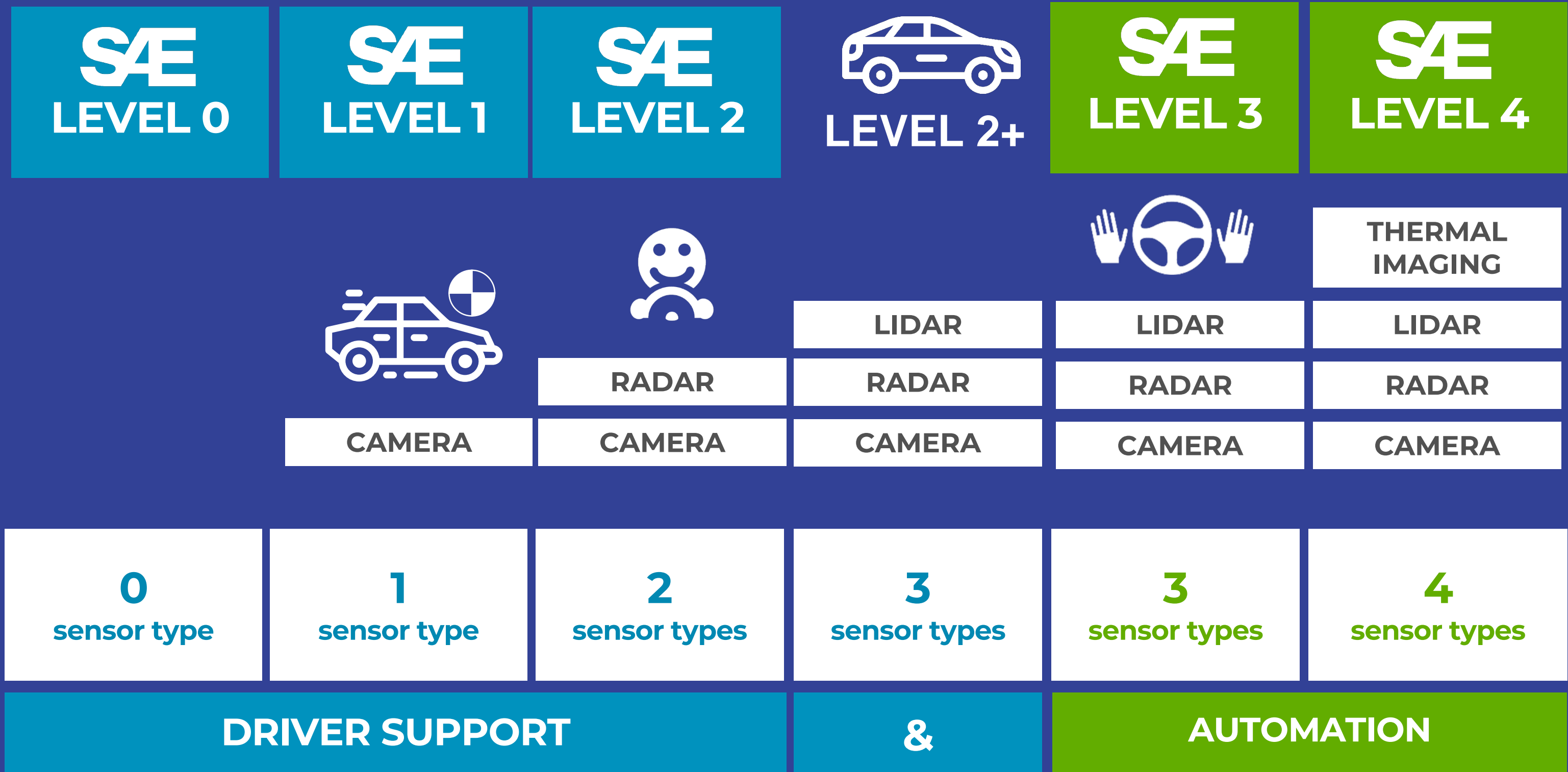

## Main AD hurdles:

Regulatory Approval

Product Liability



# NEW VALUE SPACES - CHINA CAN ACT AS THE CATALYST FOR AUTOMATION



Established players in the western hemisphere...

[&]



... agile ecosystem / favourable government

# Opportunities for local innovation

- Favorable Regulations
- Massive data collection
- Megacities boost demand
- Mobility and Delivery Platforms
- Governmental support/strategy

# ADAS & AD

**GROWTH** IS THERE



# THREE MAIN DRIVERS

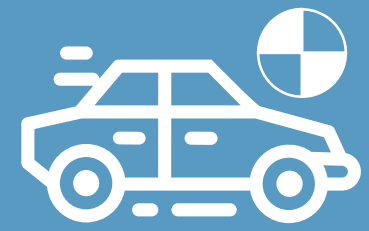

**Regulators are pushing**



**Consumers want it**



**Technology gets ready**

# REGULATION DRIVES ACTIVE SAFETY TOWARDS STANDARD FITMENT



**Regulators are pushing**

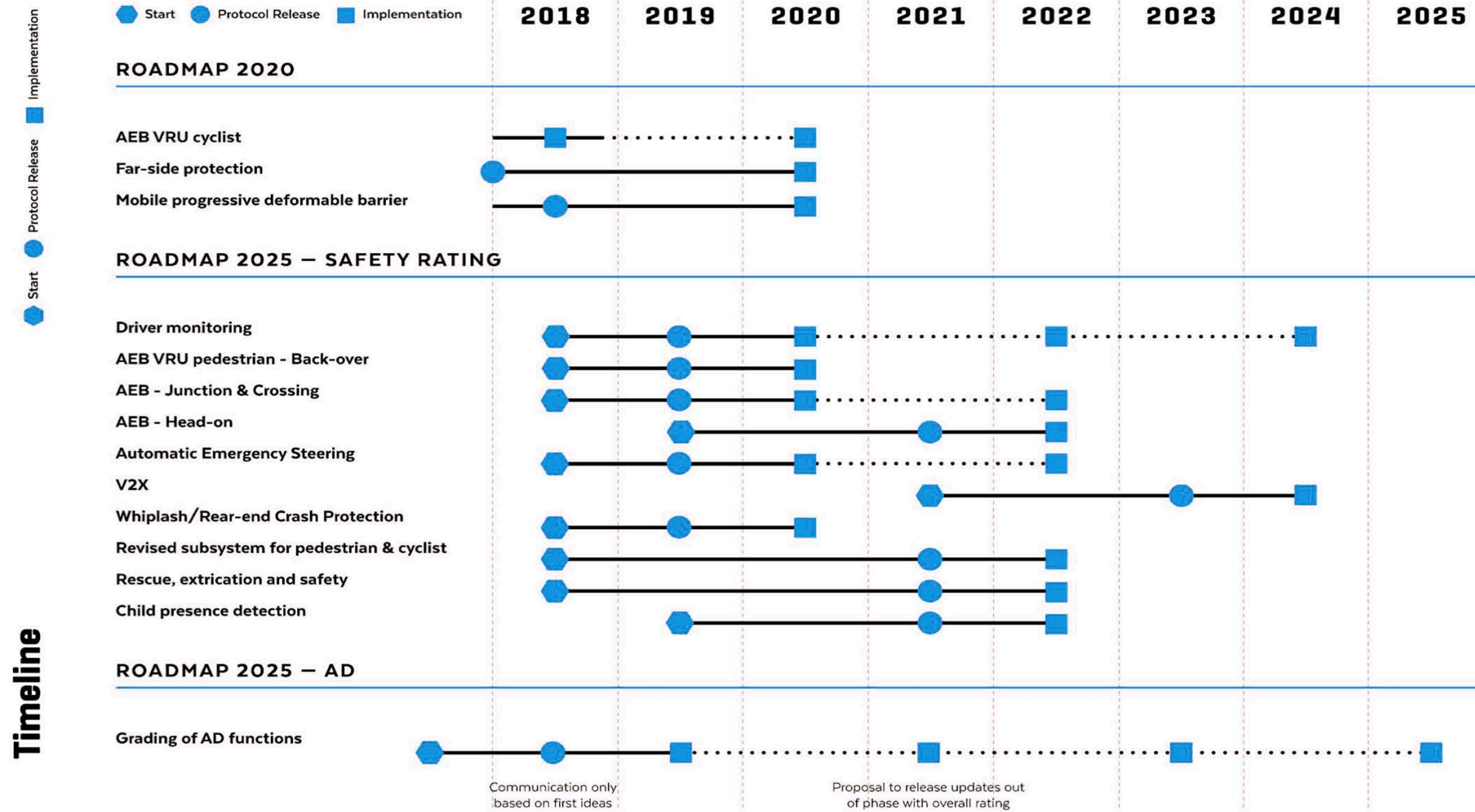

# TAKE RATES FOR ADAS SYSTEMS CONTINUE TO INCREASE



**Consumers want it**

**Regulators are pushing**

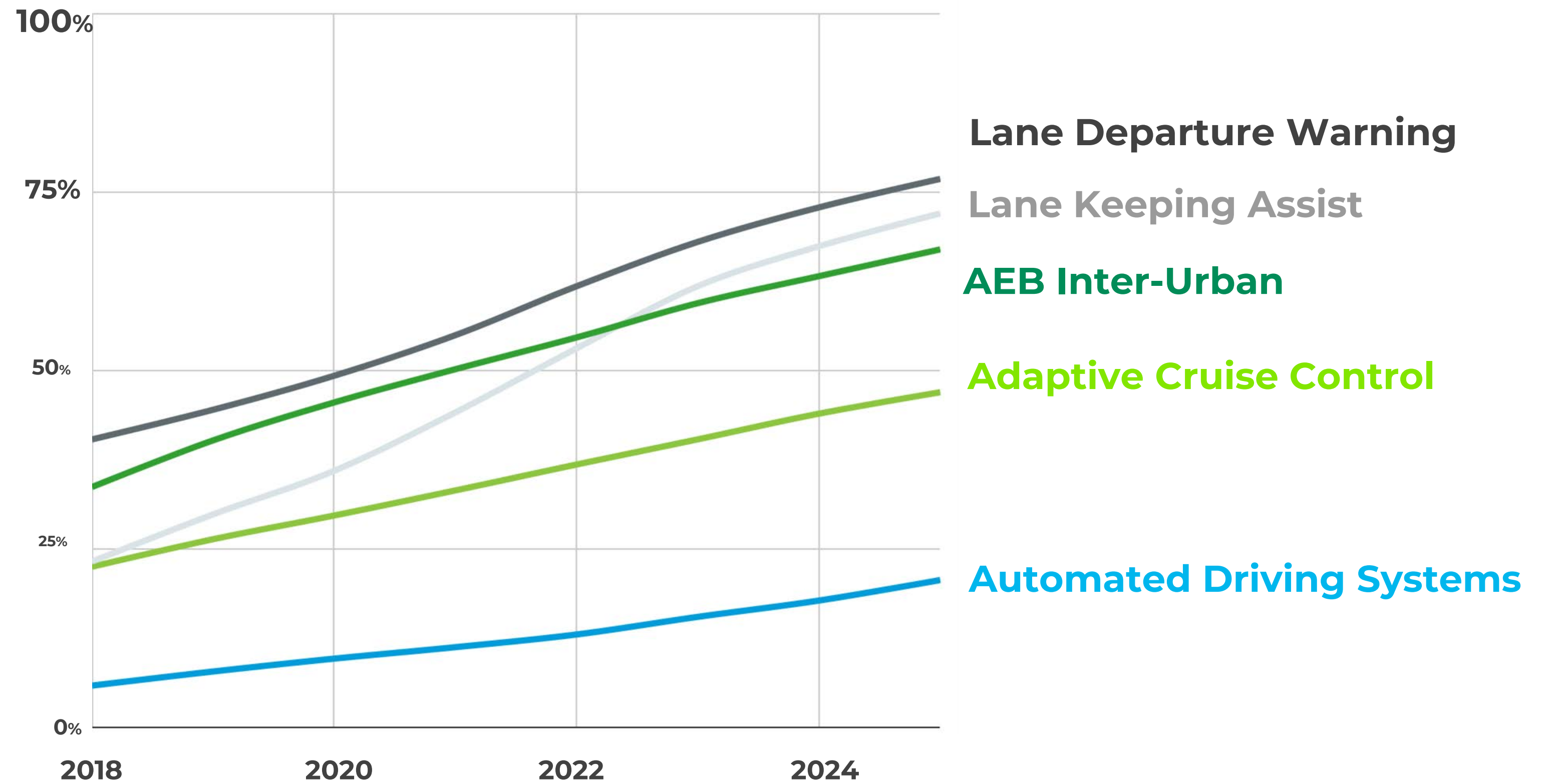

# OEMS MAKE ADAS & AD A BACKBONE IN VEHICLE ARCHITECTURE



Technology gets ready

Consumers want it

Regulators are pushing

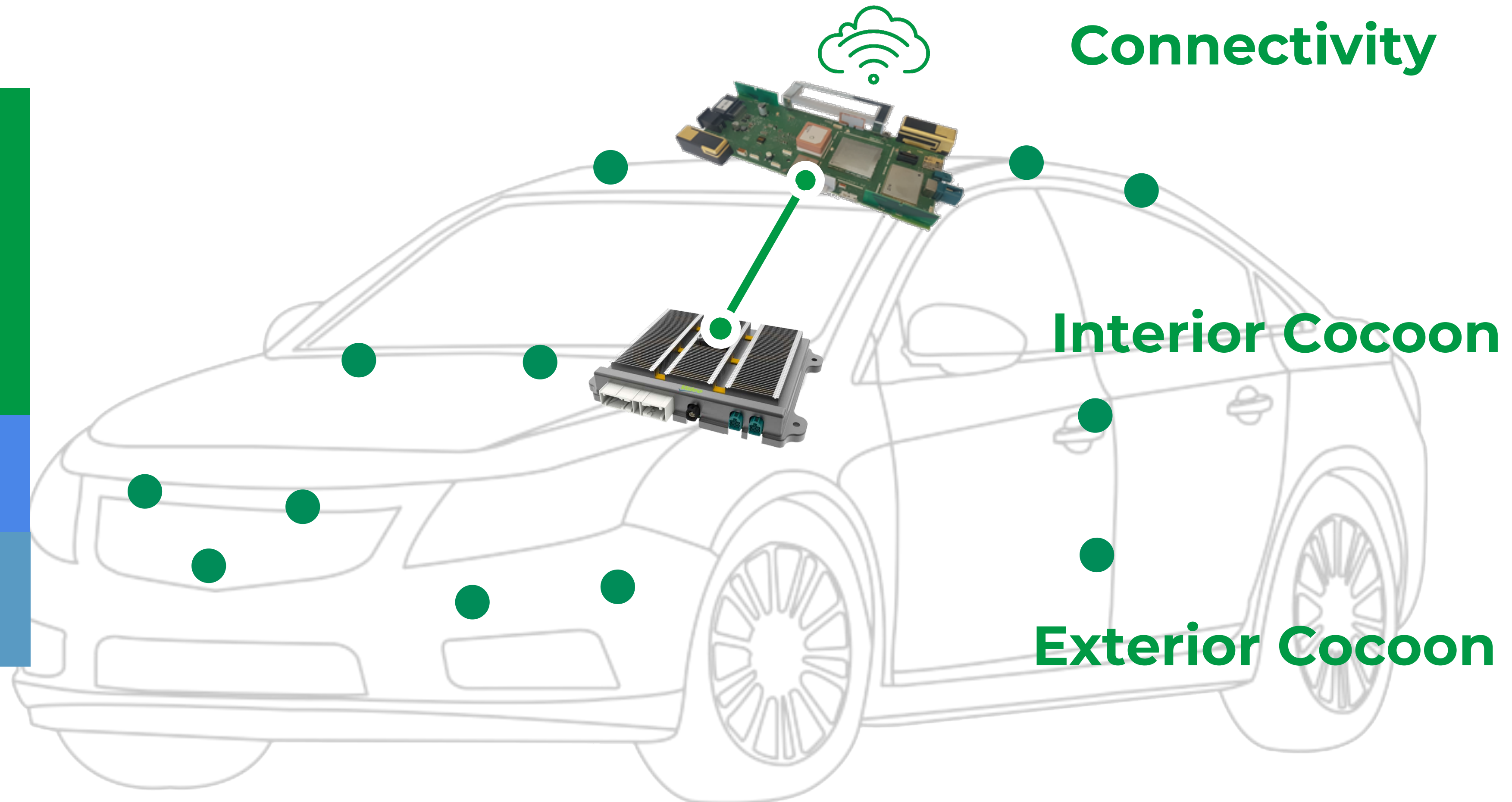

# THE HIGHER AUTONOMY LEVEL, THE MORE FUNCTIONS, THE HIGHER CONTENT FOR VALEO

## Premium

48



**L4**

Park4U Garage  
Park4U Home

AVP ready (mapped area)

**L2**

Beyond NCAP  
Emergency Evasion

**L3**

Auto Lane Change  
Stop on Hard Shoulder

Voyage<sup>XR</sup> ready

Valeo content  
[in 2025]

2 500 €

## Mainstream

24



**L2**

360Vue  
Park4U Fusion

AVP ready (mapped area)

**-**

5-star AEB  
Blind Spot

**L2**

Hands-off  
Stop in Lane

600 €

## Entry

11



**-**

Rear Camera  
Park Aid

**-**

3-star AEB  
Rear AEB

**L2**

ACC Stop&Go  
Lane Centering

200 €

Sensor Suite

Park4U<sup>®</sup>

(((Safe4U)))

Cruise4U

Full System



# A FAST GROWING MARKET

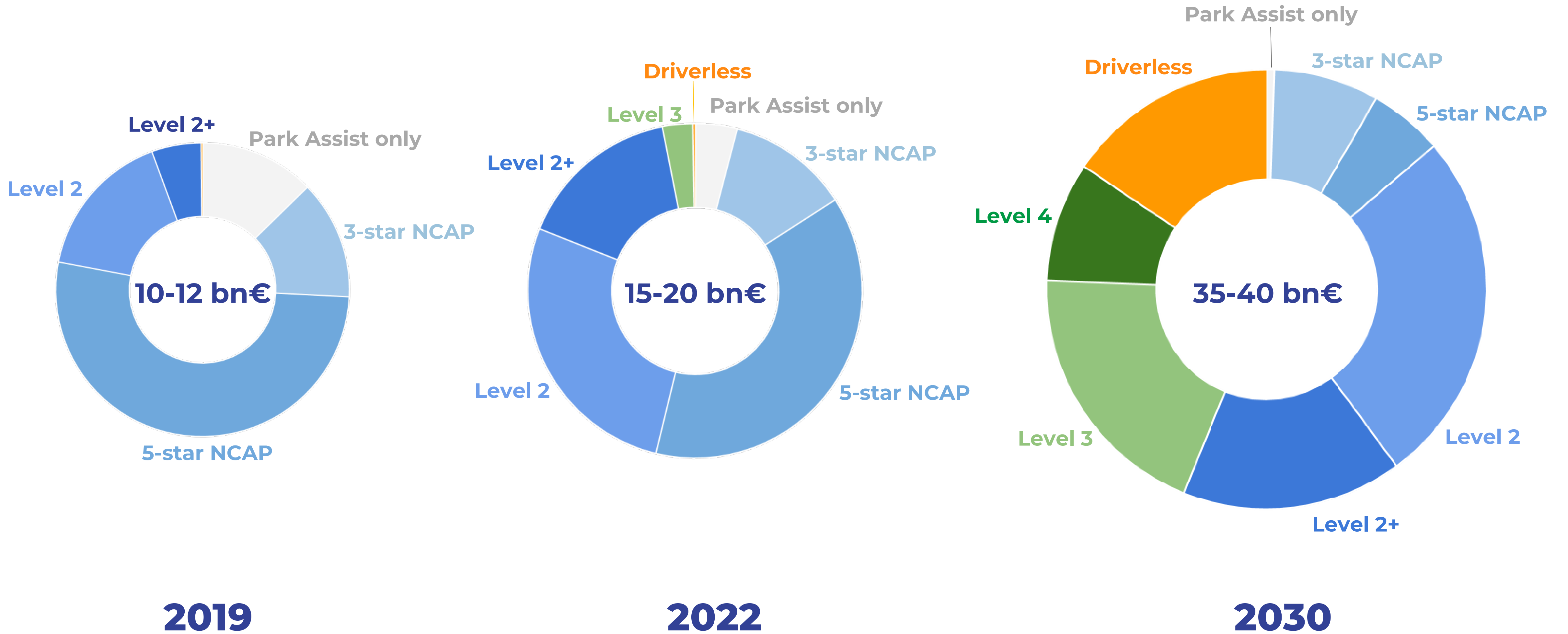

**WE HAVE BUILT**

**SUCCESSFUL TECHNOLOGICAL  
PLATFORMS**

# THE BROADEST SENSOR PORTFOLIO ON THE MARKET FOR EXTERIOR AND INTERIOR COCOONS

## INTERIOR COCOON

Driver and cabin monitoring

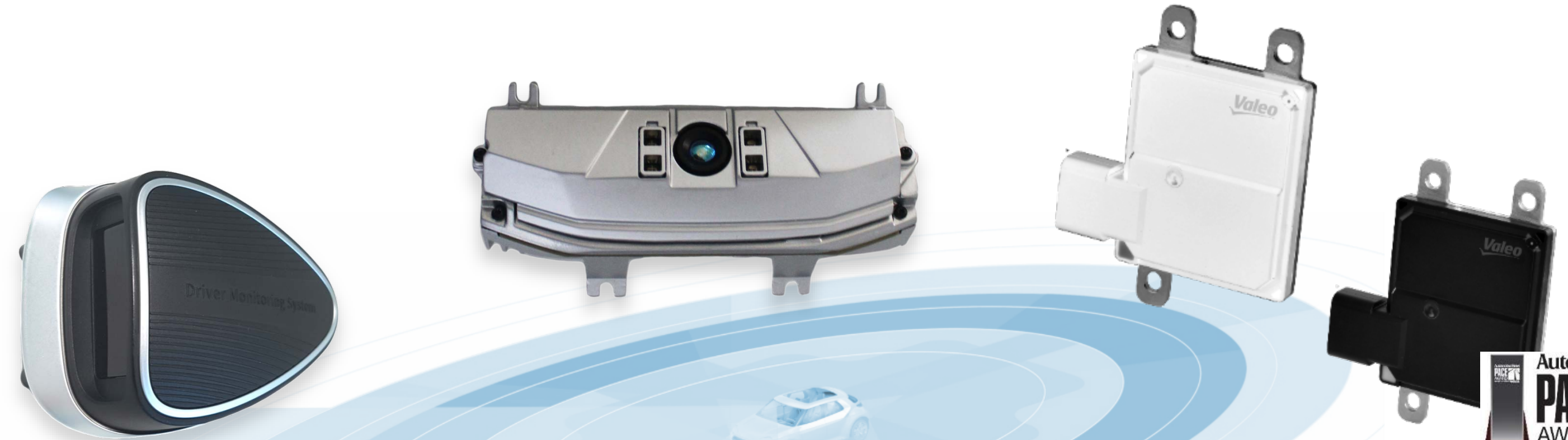

## EXTERIOR COCOON

Perception and Situational Awareness

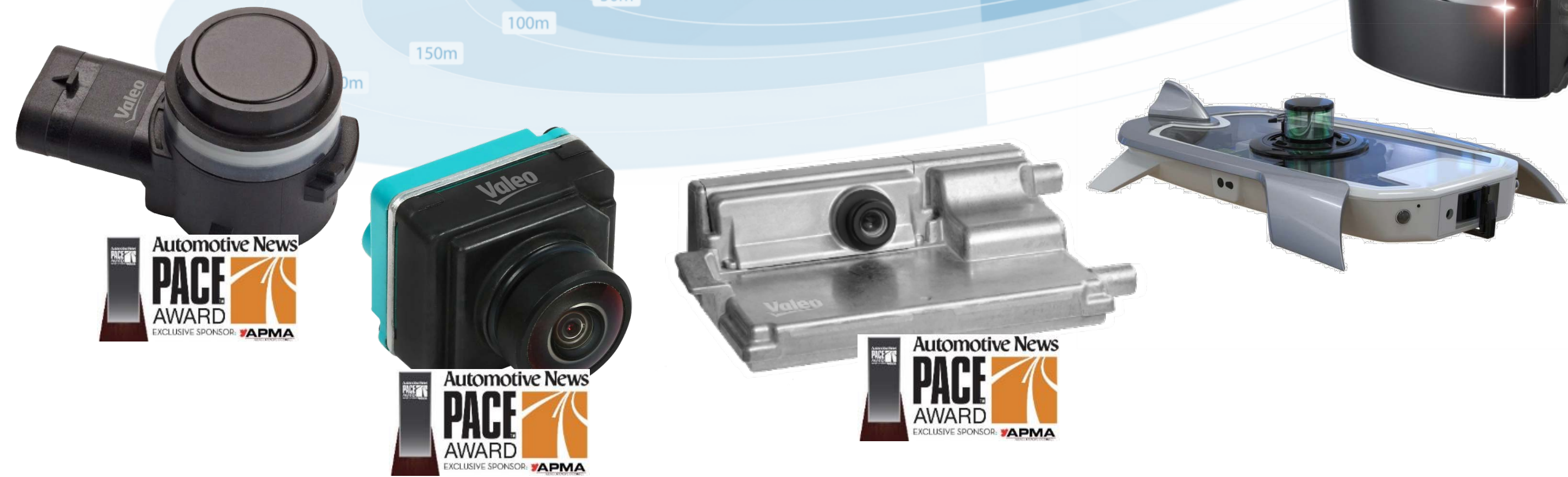



## ULTRASONIC PLATFORM



**>170mio**  
sensors in 2019

**>1.1 bn**  
sensors since 1990

**A.I. ready**  
new generation in 2021

# ARTIFICIAL INTELLIGENCE IS POWERING VALEO'S PERCEPTION SYSTEMS

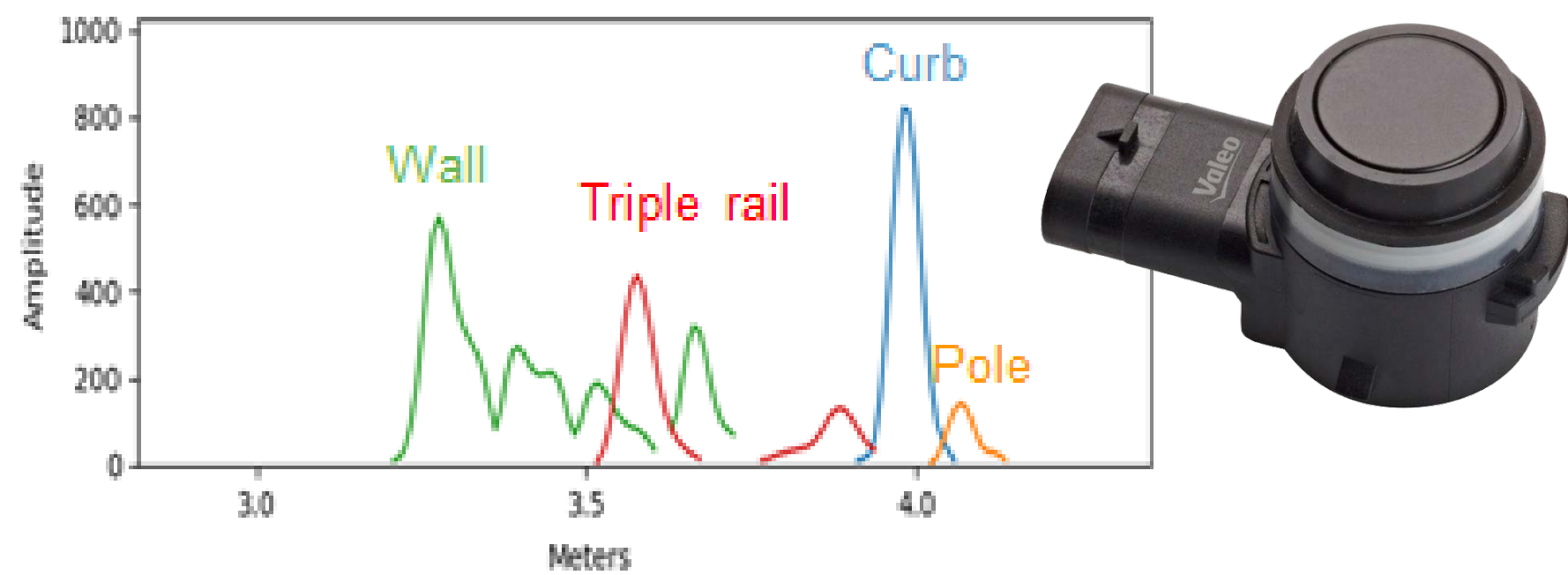

**valeo.ai**  
A dedicated team  
of researchers

A global network  
of **200+ AI Experts**

# SURROUND VIEW CAMERA PLATFORM



**35%**

market share in 2019

**XtraVue Trailer**

system launched in 2019

**12%**

camera CAGR 2019-2022

# FRONT CAMERA PLATFORM

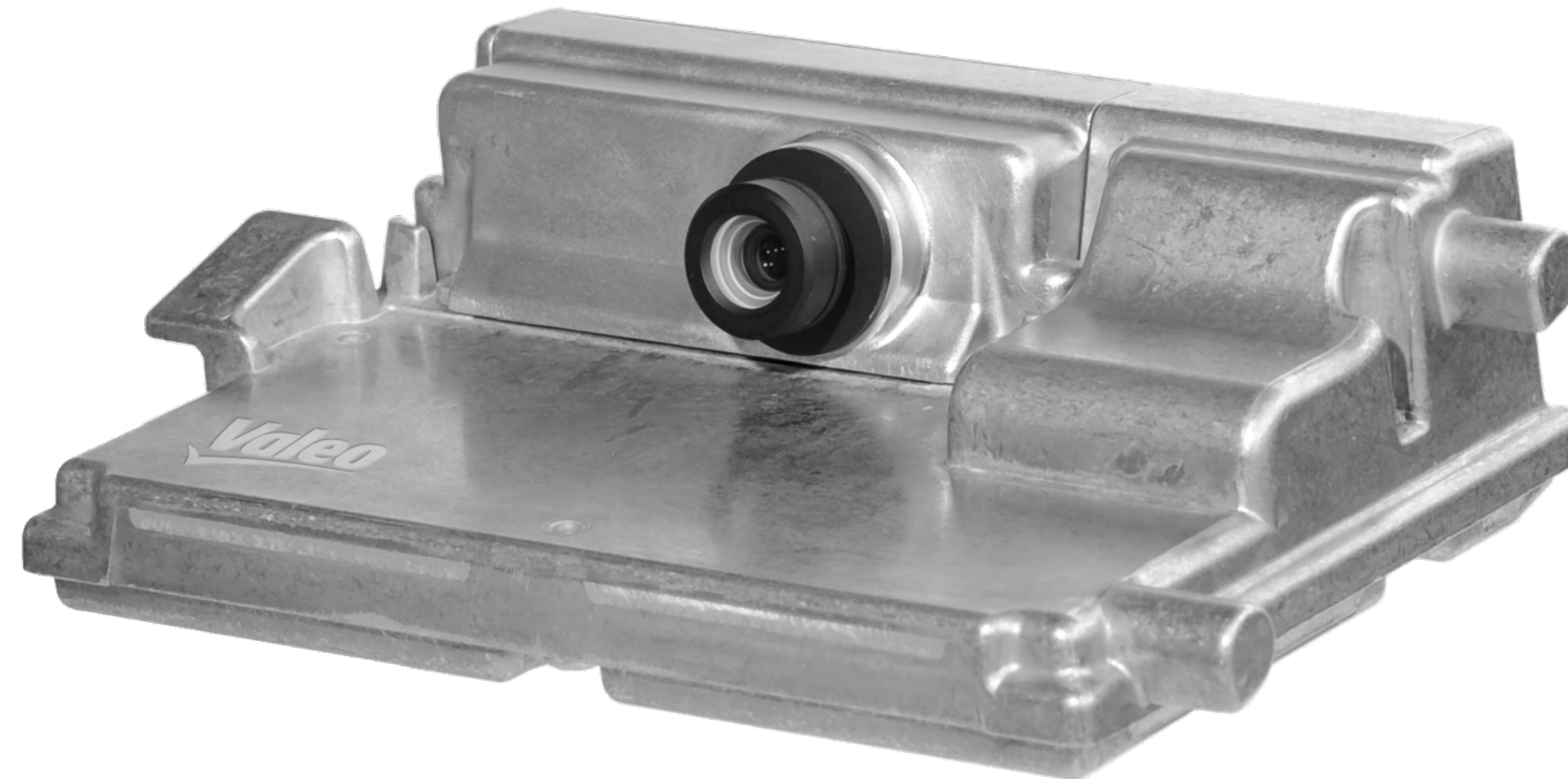

**>€4bn**

order intake since 2017

**50**

model launches in 2019/2020

**World's 1<sup>st</sup>**

Stand-alone  
SAE Level 2 in 2019

# VALEO'S SMART FRONT CAMERA LEVEL 2 ADAS SYSTEM



*Honda's Fit abolishes millimeter-wave radar, changed from Bosch to Valeo*

日経 **XTECH**  
 Nikkei Automotive Technology  
 2019, October 1st

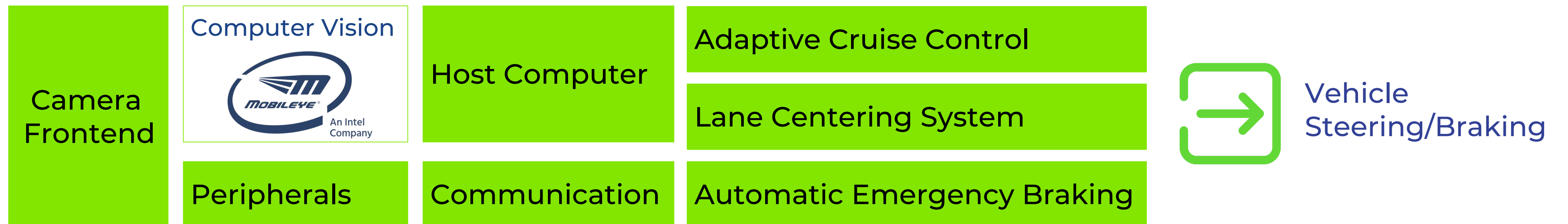

 Developed / integrated by Valeo

# DRIVER MONITORING PLATFORM



**World's 1<sup>st</sup>  
A-pillar**

**Driver Monitoring System**

**World's 1<sup>st</sup>  
Emotion**

**Detection System**

**Selfie  
Function**

**for 2021 SOP**

# LIDAR SCALA® PLATFORM



**>100 000**  
Valeo SCALA® shipped

**€500mio**  
order intake

**Key enabler**  
for safe automated driving

# LIDAR IS A KEY ENABLER FOR SAFE AUTOMATED DRIVING

**Valeo SCALA<sup>®</sup>**  
can detect

overhead objects



road debris



road markings



offset static objects





**ADAS & AD**

**SCALABLE SOFTWARE  
SYSTEM**

# WE ARE A FULL SYSTEM SUPPLIER

From architecture, design to validation and manufacturing



 **Scalable System Automated Driving**

 **Scalable System Automated Parking**

 **Full NCAP Roadmap Compliance solutions**

# SCALABLE ADAS SOFTWARE SYSTEM

AUTOMATED  
PARKING SYSTEM

Park4U<sup>®</sup>

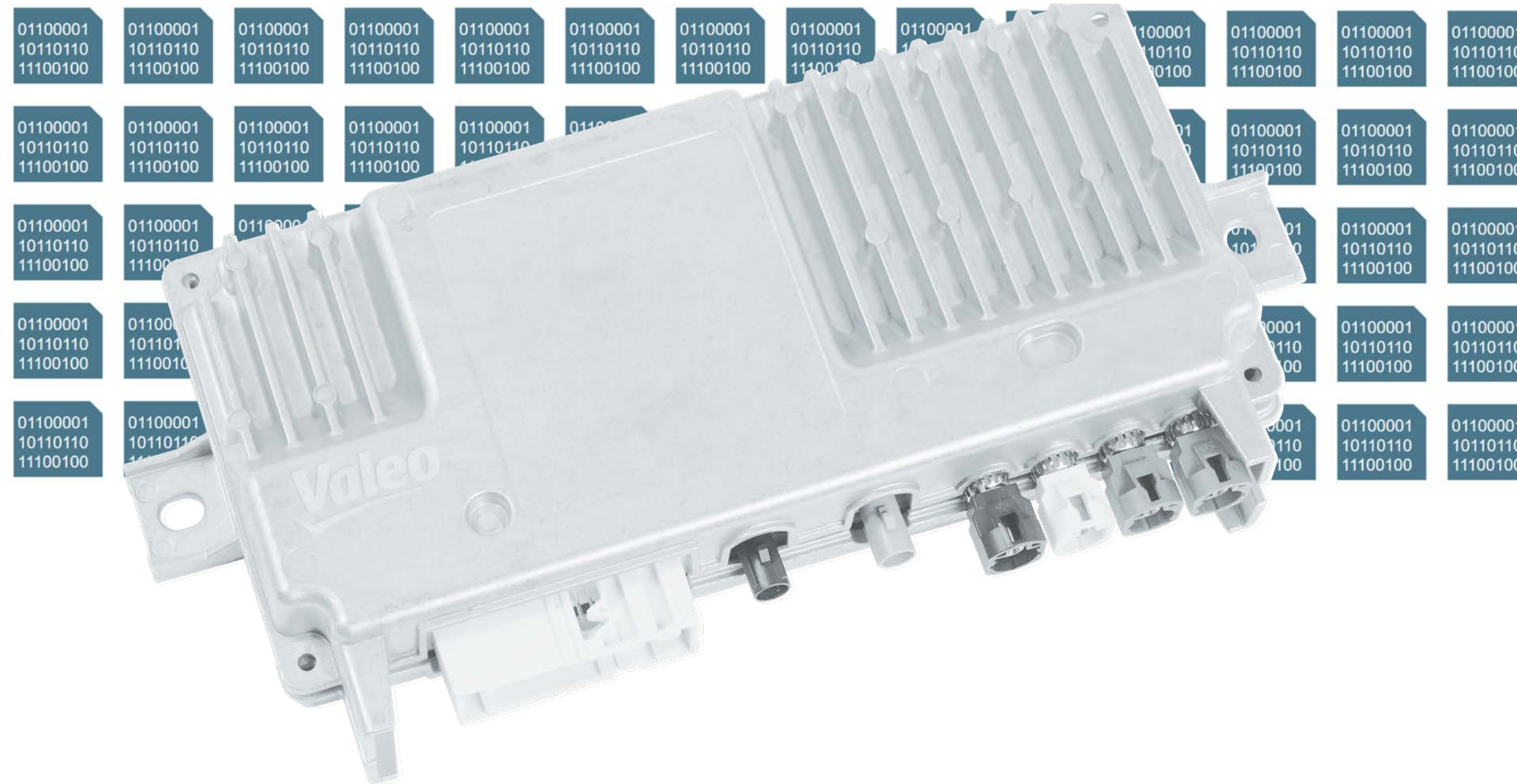

AUTOMATED  
DRIVING SYSTEM

Cruise4U

**100mio**  
lines of code in  
System and Software  
library

**70**  
validated re-configurable  
software modules

**3 500+**  
SW developers  
worldwide

**WE HAVE DEVELOPED**

**KEY ASSETS  
IN SYSTEM VALIDATION**

# WE HAVE DEVELOPED KEY ASSETS IN SYSTEM VALIDATION

## AUTOMATION

AI-based labeling  
Automatic KPI generation

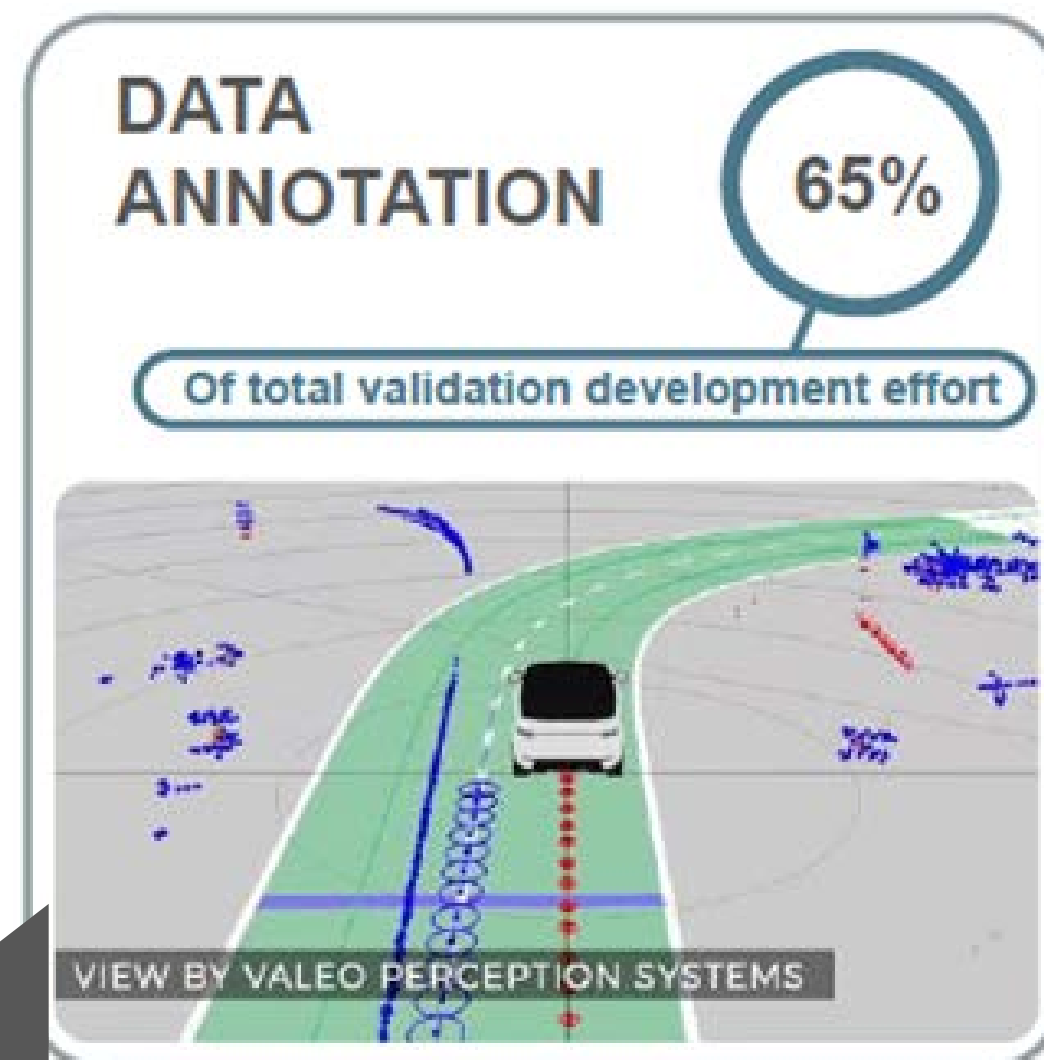

## DATA MANAGEMENT

Big data storage and archiving  
GDPR / China compliance



## VIRTUALIZATION

SIL strategy  
(Software In the Loop)  
Simulation of sensors and systems



## STANDARDIZATION

Modular Tool Chain  
and Reference Systems



# WE HAVE DEVELOPED KEY ASSETS IN SYSTEM VALIDATION

**Deterministic testing**  
test track scenarios

**Statistical testing**  
worldwide campaigns

**Reprocessing of recorded data**  
in SIL/HIL environment

**Virtual World testing**  
in simulation environment



**12**

**Petabyte Recorded Data**

**6**

**Vehicle Test Tracks**

**>100**

**Test vehicles**

# WE HAVE DEVELOPED KEY ASSETS IN SYSTEM VALIDATION

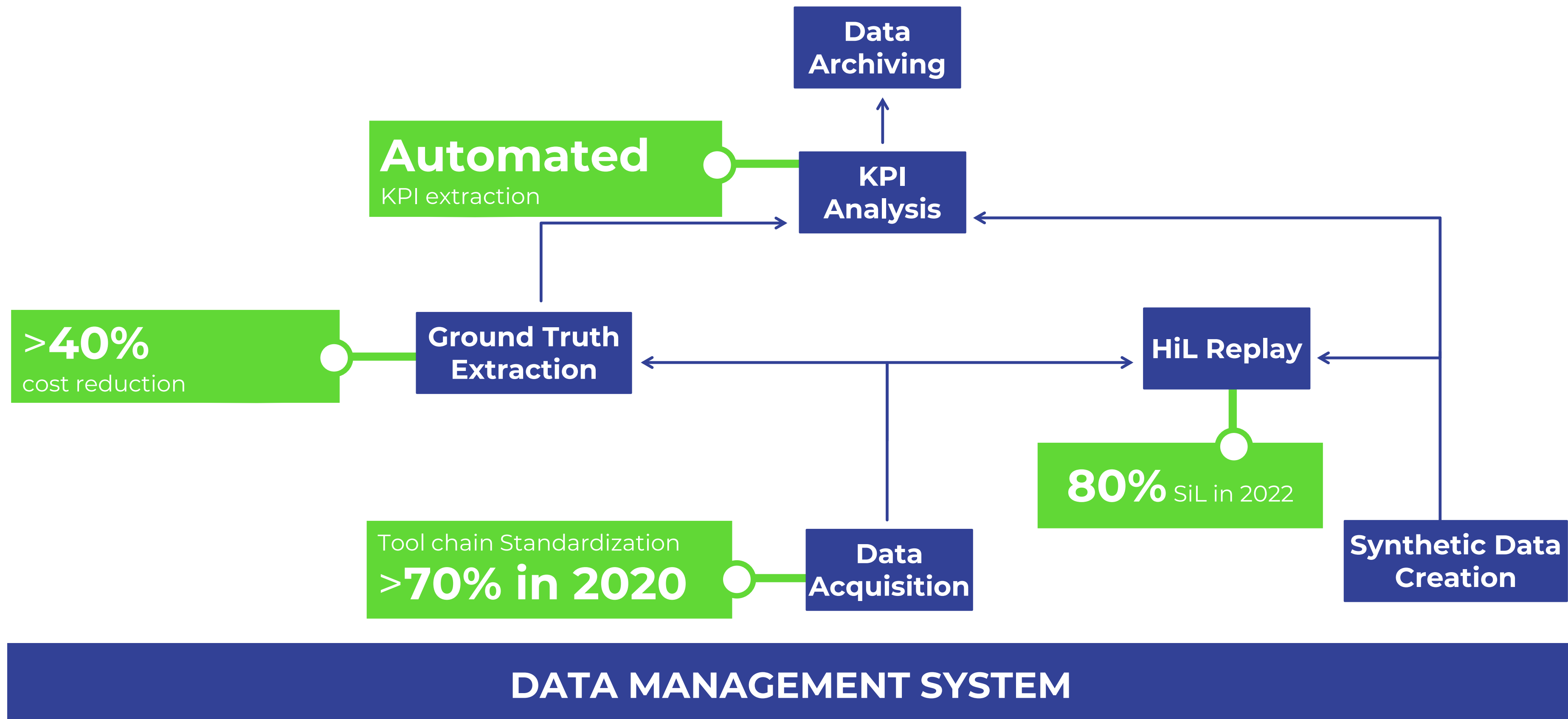

**WE HAVE BUILT SUCCESSFUL TECHNOLOGICAL PLATFORMS**

**WE LEVERAGE  
OUR TECHNOLOGICAL PLATFORMS  
WITH NEW VALUE SPACES**



# WE ARE A KEY PARTNER TO NEW MOBILITY PLAYERS

  
**DRIVERLESS**

  
AUTOMATED DRIVING

  
DRIVER SUPPORT

  
ACTIVE SAFETY

**PERCEPTION:**

**FULL SENSOR PORTFOLIO INTEGRATION,  
CLEANING AND PERCEPTION ALGORITHMS**

**FUNCTIONS:**

**MAPPING AND LOCALIZATION**



**TELEOPERATION**





# WE ARE A KEY PARTNER TO NEW MOBILITY PLAYERS

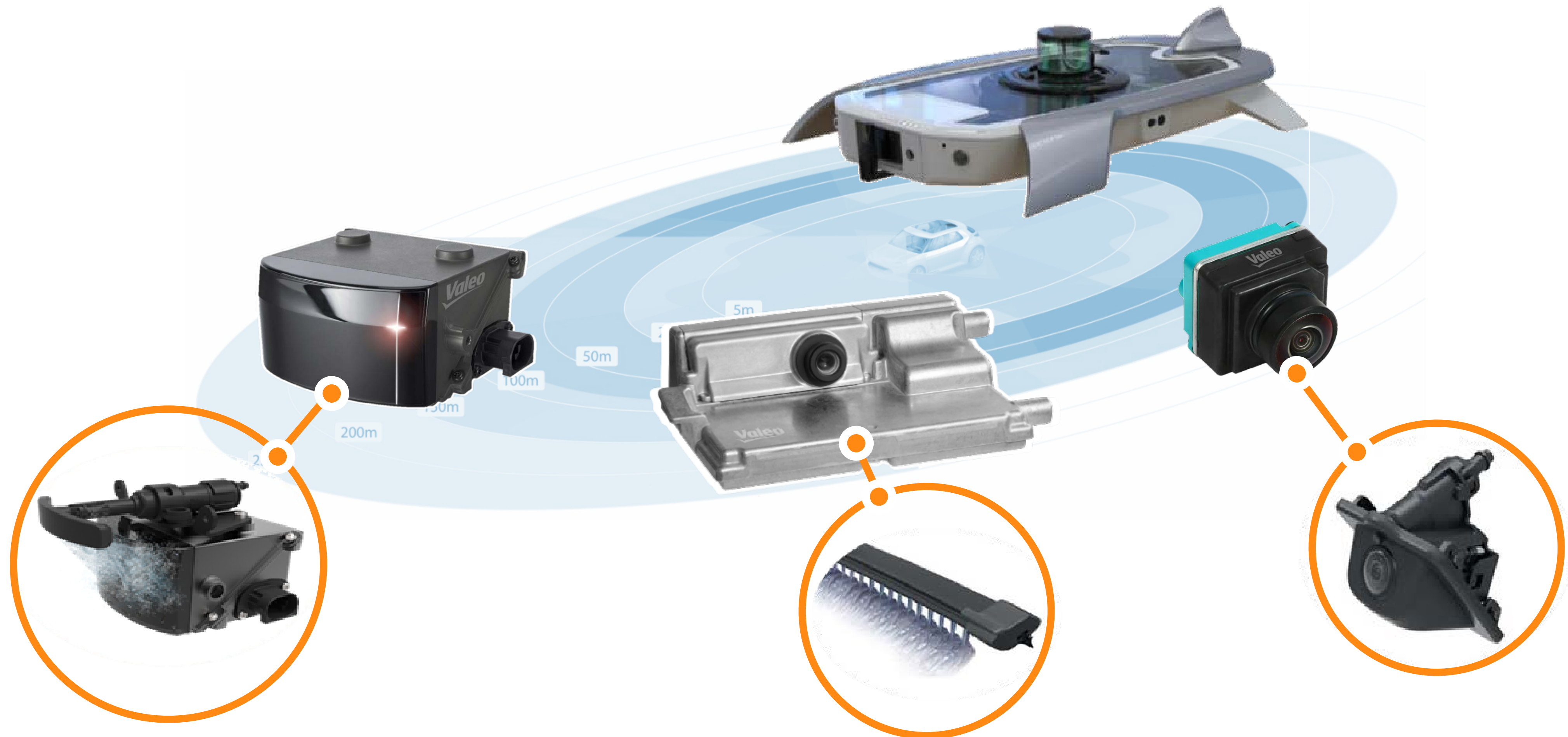

**ENSURING AVAILABILITY OF SERVICE  
THROUGH AUTOMOTIVE GRADE QUALITY**



January 7-10, 2020

# SMART MOBILITY IS MORE THAN CARS



# 30 YEARS OF SUCCESSFUL INNOVATION

**1991** Ultrasonic Parking Aid

**1995** Mirror-integrated Rain Sensor

**1998** Programmable ASIC

**2004** Lane-Departure Warning

**2006** Multi-beam Radar

**2006** Rear Camera w/ distance overlay

**2007** Semi-automatic Park Assist

**2009** Rain-Light-Humidity Sensor

**2009** 5-camera Surround View

**2009** Cross Traffic Alert

**2010** Perpendicular & Braking Park Assist

**2010** Seamless Top View

**2011** Parking Aid w/ flankguard

**2013** Rear Camera w/ obj. detection

**2015** Multi-function Front Camera

**2015** Map-based Park Assist

**2015** Hidden ultrasonic installation

**2015** 3D Surround View w/ obj. detection

**2016** Park Assist w/ remote option

**2016** Parking Domain ECU

**2017** Automotive-grade 3D Laser Scanner

**2020** Laser Scanner w/ increased vFoV

**2020** Front Camera w/ 100° lens

**2020** Vision-only L2 driving function

**2020** Invisible Trailer rear view

**2021** Camera design for high resolution

**2021** New vision/fusion based features

**2021** New Ultrasonic Sensor Interface

**Awards:** Automotive News PACE AWARD, Deloitte APMA 2020 FINALIST

# THE LEADER IN ADAS & AD

**>€11bn**  
order intake  
2017-2019

**18%**  
CAGR  
2019-2022

**~€3.2bn**  
Sales in  
2022

**IT IS JUST**

**THE BEGINNING**

# SAFE HARBOR STATEMENT

Statements contained in this document, which are not historical fact, constitute “forward-looking statements”.

These statements include projections and estimates and their underlying assumptions, statements regarding projects, objectives, intentions and expectations with respect to future financial results, events, operations, services, product development and potential, and statements regarding future performance. Even though Valeo’s Management feels that the forward-looking statements are reasonable as at the date of this document, investors are put on notice that the forward-looking statements are subject to numerous factors, risks and uncertainties that are difficult to predict and generally beyond Valeo’s control, which could cause actual results and events to differ materially from those expressed or projected in the forward-looking statements. Such factors include, among others, the Company’s ability to generate cost savings or manufacturing efficiencies to offset or exceed contractually or competitively required price reductions. The risks and uncertainties to which

Valeo is exposed mainly comprise the risks resulting from the investigations currently being carried out by the antitrust authorities as identified in the Registration Document, risks which relate to being a supplier in the automotive industry and to the development of new products and risks due to certain global and regional economic conditions. Also included are environmental and industrial risks as well as risks and uncertainties described or identified in the public documents submitted by Valeo to the French financial markets authority (Autorité des marchés financiers – AMF), including those set out in the “Risk Factors” section of the 2018 Registration Document registered with the AMF on March 29, 2019 (under number D.19-0224).

The Company assumes no responsibility for any analyses issued by analysts and any other information prepared by third parties which may be used in this document. Valeo does not intend or assume any obligation to review or to confirm the estimates of analysts or to update any forward-looking statements to reflect events or circumstances which occur subsequent to the date of this document.

**VALEO**

**INVESTOR DAY**

— Paris 2019 —