

## Applications

- Broadcast
- Harsh Environment
- Long-haul Networks
- Military

## Features

- Non-reflective black matte finish
- Integrated cam-lock/drag system
- Velcro cable/connector straps
- Rugged construction
- Built-in crank handle

## Benefits

- Secure assembly storage
- Easy method of transport
- Fast deployment and extraction
- Eliminates slack during install/recoil
- Holds cable/connectors secure during transport
- Highly durability in demanding environments

## About Timbercon

Timbercon, Inc., founded in 1997, is a fiber optic product and solution manufacturing company providing a variety of connectivity solutions to the defense, aerospace, medical, data storage, telecommunications, industrial, broadcast and networking industries. In addition to standard fiber optic assemblies and attenuated loopbacks, Timbercon has pioneered many proprietary products. Additional company information can be found at [www.timbercon.com](http://www.timbercon.com).

## Overview

Timbercon deployable reels offer a number of advantages for applications requiring long fiber runs, temporary connections or easy storage and transportation of long, bulky cable assemblies. Developed to work in conjunction with tactical, multi-fiber and outside plant type assemblies, Timbercon's deployable reels utilize rugged metal construction with a number of user accessible features to facilitate the rapid deployment or recoil of any fiber optic cable assembly.

Timbercon deployable reels are heavy duty, hardwearing and provide connector and cable protection when they are not in use. The use of deployable reels also prevents handling damage and allows for cable testing to be done on the reel prior to installation.

Deployable reels are available in multiple sizes, configurations and mount types to suit a wide variety of applications and cable assembly types. For application specific requirements, Timbercon deployable reels can be easily customized to provide an ideal, project-specific solution.



# Deployable Reels

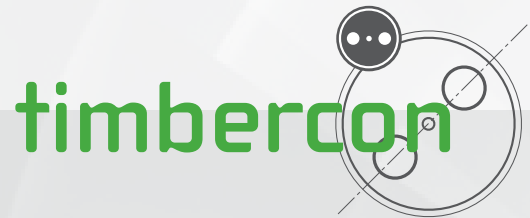

## Small Deployable Reel

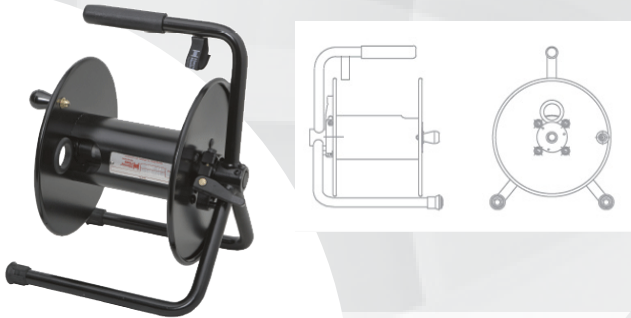

- Crank handle permanently attached to disc
- Equipped with cam-lock/drag brake system
- Equipped with Velcro cable fastener
- Non-reflective black matte finish standard



## Large Deployable Reel

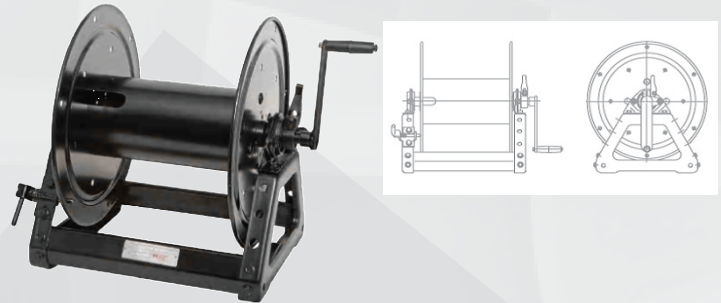

- Standard direct crank, permanently attached
- Manual rewind models, spring actuated pin-lock, cam-lock/drag brake
- Non-reflective black matte finish options
- Heavy-duty locking caster wheel set, includes 2 locking and 2 non-locking casters with mounting plates
- Frame mounted carry handles
- Divider discs, available with a cut-out (Note: this disc location must be specified)

## Construction

	Small Deployable Reel	Large Deployable Reel
Weight (w/o cable assembly)	17 lbs.	33 lbs.
Dimensions (inches) W x H x D	15.5 x 19 x 12.75	16.5 x 18.12 x 32.5
Carrying Capacity (Meters)		
6mm OD Cable	335	1994
7mm OD Cable	245	1458
8mm OD Cable	188	1120
9mm OD Cable	149	887
10mm OD Cable	120	719
11mm OD Cable	100	592
12mm OD Cable	84	498
13mm OD Cable	72	425

20245 SW 95th Avenue • Tualatin, OR 97062 • USA  
 503.827.8141 • 800.221.6992 • 503.228.6747 fax  
 www.timbercon.com • info@timbercon.com