

Your equipment. Our responsibility.



SHIPPING SOLUTIONS FROM
MUELLER TRANSPORTATION, INC.

MUELLER

Get to Know Mueller Transportation, Inc.

MUELLER TRANSPORTATION, INC. (MTI) excels in transporting freight of any size safely, timely, and directly to your specified destination. Our commitment lies in on-time delivery, with our experienced team utilizing our specialized trailers within our state-of-the-art fleet to offer tailored solutions for your transportation needs.

Our dedication enables MTI to cater to a diverse range of freight needs, from the routine to the extraordinary. Our pledge to you is a service that embodies safety, timeliness, professionalism, and readiness, equipped with the resources and determination to meet and even exceed your expectations in freight delivery.

MUELLER

TRANSPORTATION, INC.





A Safe Partner for Your Transportation Needs

YOUR EQUIPMENT. OUR RESPONSIBILITY.

MTI specializes in customized solutions for your oversized freight requirements. Our dedicated team prioritizes the safe and timely delivery of your equipment, treating each shipment with the utmost care.

- Specialty hauling equipment.
- Custom-engineered cradles and structures ensure your load is secure and protected.
- Skilled and knowledgeable professional drivers handle your equipment with care.
- Comprehensive planning and scheduling facilitate seamless delivery and offloading at your site.

ENSURE YOUR PEACE OF MIND.

At MTI, we meticulously plan and manage the intricate risks of transporting your cargo. Our mission is to address and solve logistical challenges before they reach you, ensuring a seamless journey for your load.

- Expert management of weather-related and construction-based logistics.
- Rigorous adherence to compliance with federal, state, county, and local regulations.
- Implementation of a formalized safety training program, prioritizing the security of our drivers, equipment, and your cargo.
- Customized insurance coverage, designed for oversized freight.

CONTACT US TO EXPLORE SHIPPING SOLUTIONS FOR YOUR NEXT PROJECT!

MTI Trailer Fleet

SPECIALIZED EQUIPMENT FOR SPECIALIZED NEEDS.

As cargo dimensions grow, navigating the complex network of regulations for oversized freight becomes more challenging and requires a blend of creativity and expertise. At MTI, we understand that each piece of oversized freight comes with unique transportation requirements and that is why we have invested in a diverse fleet of trailers. Our array includes everything from perimeter trailers to steerables, ensuring we have the best solution for your freight. Partnering with MTI means gaining a dedicated ally throughout the entire process. From design enhancements to loading, our expert team is here to support you every step of the way to guarantee the safe and efficient delivery of your freight.

With MTI, you gain a partner adept at transforming logistical challenges into seamless operations, tailored just for your specialized freight needs.



Conestoga

48" LONG.

The conestoga trailer features a protective cover designed for products that are difficult to tarp or shrink-wrap.

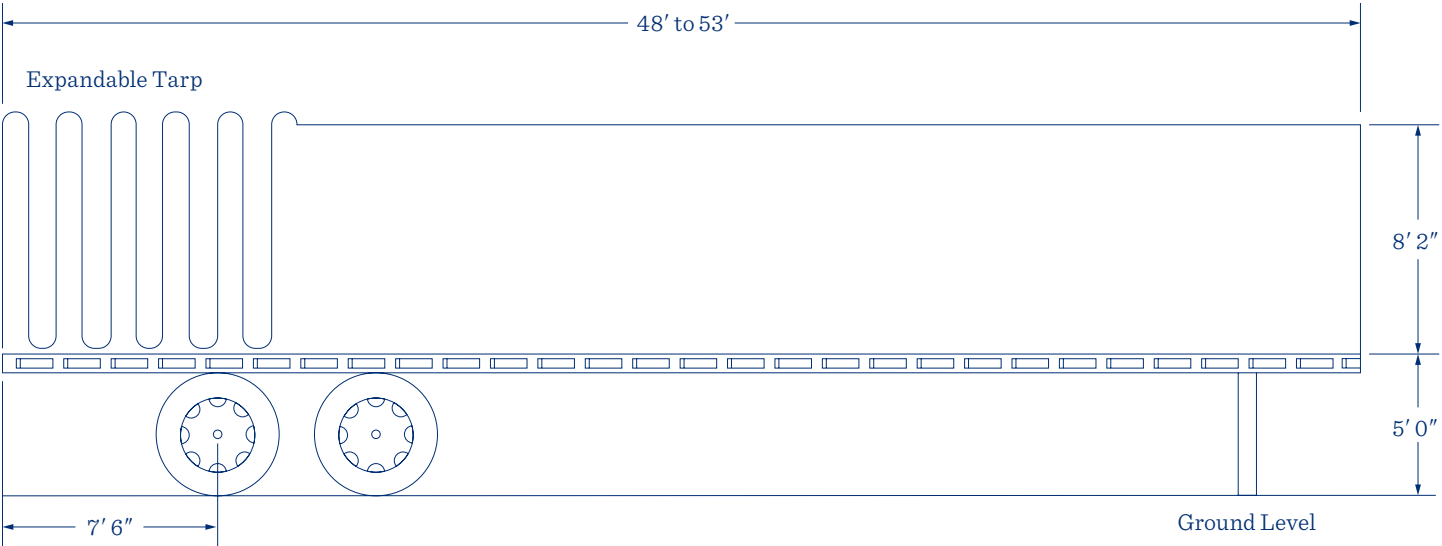

MTI Trailer Fleet

Step Deck

48" TO 53" LONG.

Both closed and spread axle (California and Canada), the step deck trailer features a low deck height to accommodate taller loads.



Spread axle step deck trailer.

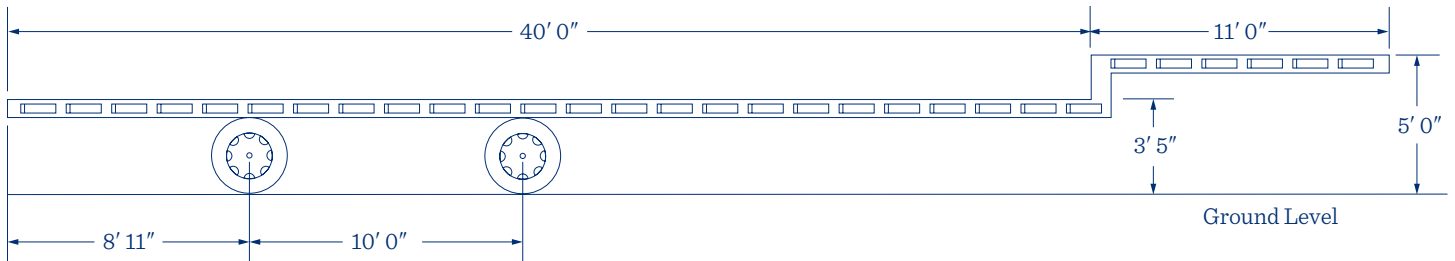

Closed axle step deck trailer.

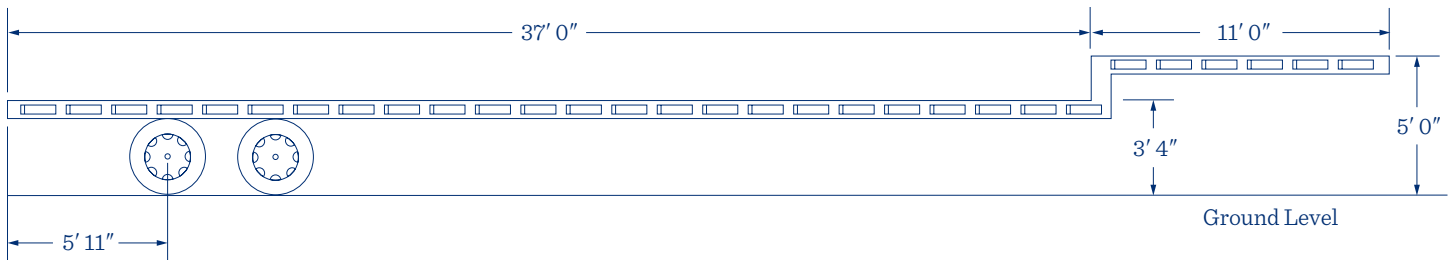

Flat Bed

48" LONG.

The flat bed trailer is a versatile and standard option, ideal for transporting a wide range of product sizes to meet diverse transportation requirements.

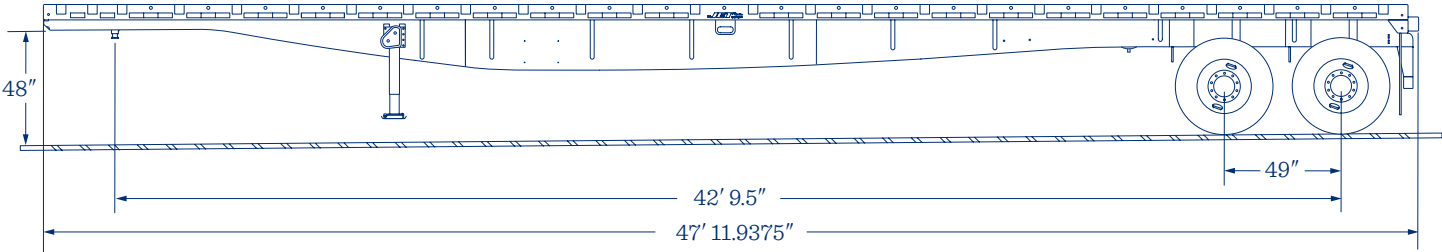

MTI Trailer Fleet

Talbert

102" TO 144" LONG.

The talbert trailer is a specialized unit designed for transporting exceptionally tall cylindrical products.

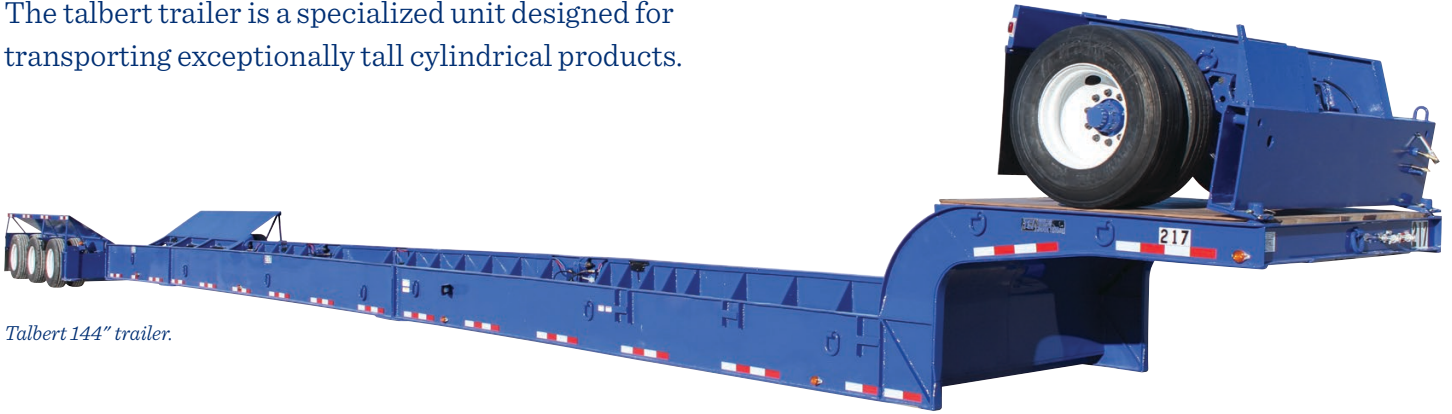

Talbert 144" trailer.

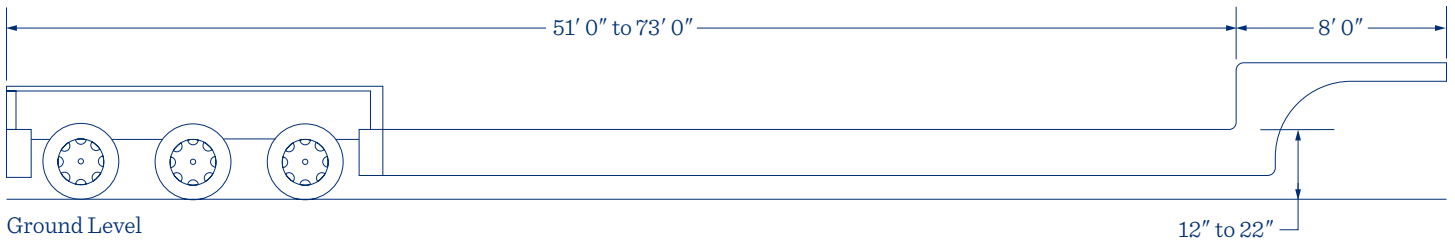

Talbert 102" trailer.

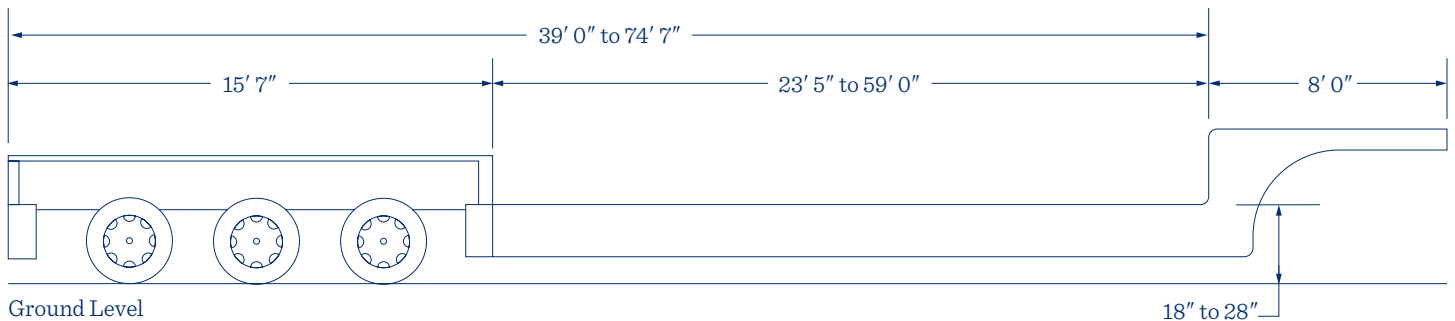

Perimeter

48" TO 52" LONG.

The perimeter trailer is a specialized model featuring a low 12-inch deck height, designed to accommodate exceptionally tall loads.

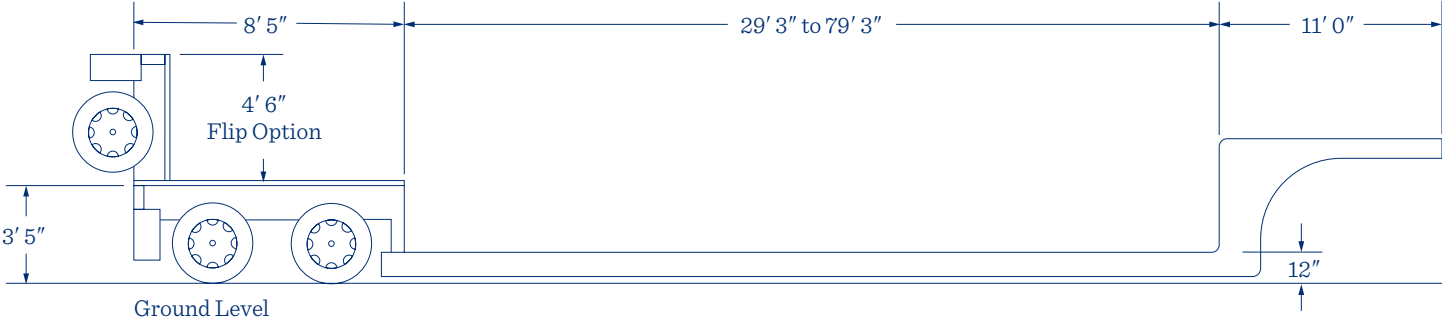

MTI Trailer Fleet

Steerable

112" LONG.

The steerable trailer is a specialized vehicle designed to transport the largest and longest loads, featuring advanced steering capabilities to navigate tight turns effortlessly.

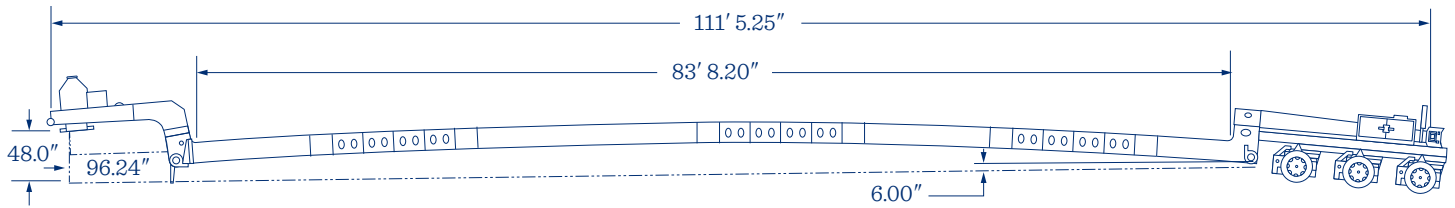
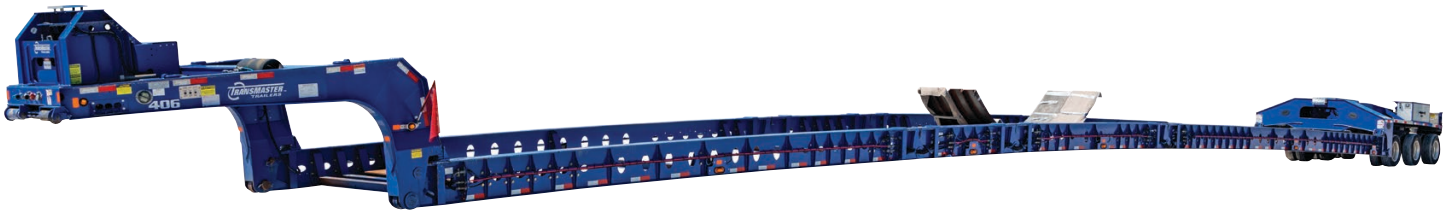

RGN (Removable Goose Neck)

48" TO 53" LONG.

The RGN is a specialized trailer designed to haul tall loads and features a removable gooseneck on the front

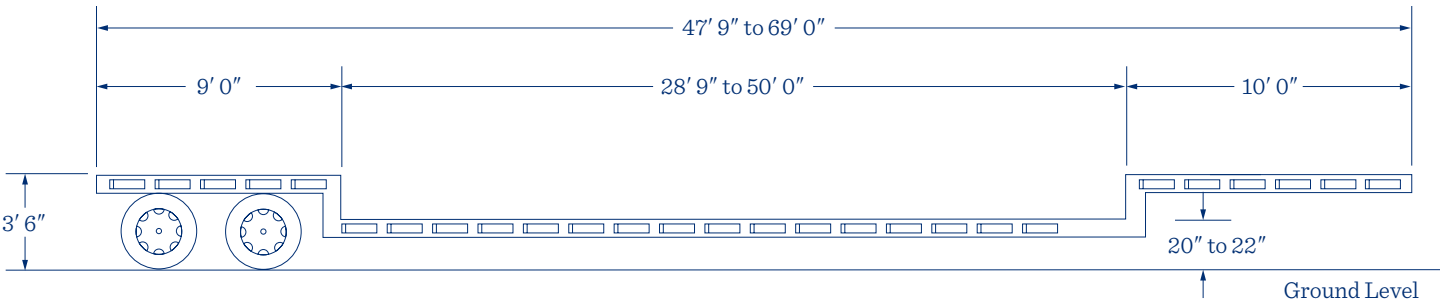

MUELLER

TRANSPORTATION, INC.



CONTACT US TO EXPLORE SHIPPING SOLUTIONS FOR YOUR NEXT PROJECT!

transportation@paulmueller.com

417-575-9000 | WWW.PAULMUELLER.COM

©2024 Paul Mueller Company | 24-2403180225p | FF-1810-1