



governmentattic.org

"Rummaging in the government's attic"

Description of document: Consumer Product Safety Commission (CPSC) Agency Brand Guidelines 2023

Requested date: 2023

Release date: 05-May-2023

Posted date: 11-September-2023

Source of document: U.S. Consumer Product Safety Commission
4330 East West Highway
Bethesda, MD 20814
Fax: 301-504-0127
Email: CPSCFOIARequests@cpsc.gov
[CPSC e-FOIA Public Access Link Website](#)

The governmentattic.org web site ("the site") is a First Amendment free speech web site and is noncommercial and free to the public. The site and materials made available on the site, such as this file, are for reference only. The governmentattic.org web site and its principals have made every effort to make this information as complete and as accurate as possible, however, there may be mistakes and omissions, both typographical and in content. The governmentattic.org web site and its principals shall have neither liability nor responsibility to any person or entity with respect to any loss or damage caused, or alleged to have been caused, directly or indirectly, by the information provided on the governmentattic.org web site or in this file. The public records published on the site were obtained from government agencies using proper legal channels. Each document is identified as to the source. Any concerns about the contents of the site should be directed to the agency originating the document in question. GovernmentAttic.org is not responsible for the contents of documents published on the website.



May 05, 2023

Via Email and WatchDox

RE: Freedom of Information Act Request #23-F-00355: A copy of each adopted/finalized brand/style guide at CPSC. This is probably in the public affairs or external affairs or legal office at CPSC.

Thank you for your Freedom of Information Act (FOIA) request seeking the above-referenced information from the U.S. Consumer Product Safety Commission (CPSC). In response to your request, please find copies of the CPSC's Brand Guidelines.

CPSC considered the foreseeable harm standard when reviewing these records.

If you need any further assistance, or you would like to discuss any aspect of your request, please contact me, or one of CPSC's FOIA Public Liaisons, Korinne Super (ksuper@cpsc.gov) or Cooper Gerus (cgerus@cpsc.gov), via email or at 1-800-638-2772.

Fees. We are not charging you fees in this instance to cover the costs to the CPSC in processing this request, performing the file searches and preparing the information.

Sincerely,

Amanda
Civins

Digitally signed by
Amanda Civins
Date: 2023.05.05
15:13:43 -04'00'

Amanda Civins
Attorney
Office of the General Counsel
Division of Information Access
P: 301-504-7630
E: acivins@cpsc.gov

Enclosures: CPSC Brand Guidelines



United States
Consumer Product Safety Commission

BRAND GUIDELINES

Visual Identity



Table of Contents

Section One Introduction

1.1 Defining a Brand.....	5
1.2 The Consumer Product Safety Commission.....	5

Section Two Logos

2.1 Logo Usage	7
2.2 Incorrect Use of Logo.....	9
2.3 Seal Usage.....	10
2.4 Incorrect Use of Seal.....	11
2.5 Logo Placement.....	12
2.6 Partner Logo Placement.....	13

Section Three Typography

3.1 Approach to Brand Fonts.....	15
3.2 Brand Fonts.....	16
3.3 Alternative Fonts.....	17
3.4 Font Sizing.....	18
3.5 Incorrect Use of Typography.....	19
3.6 Type and Color.....	20

Section Four Grid Systems

4.1 Approach to Grid Systems.....	22
4.2 Print Material Grids.....	23
4.3 Digital Material Grids.....	26

Section Five Color Palettes

5.1 Overview and Approach to Color.....	28
5.2 Brand Colors.....	29
5.3 Accent Colors.....	29
5.4 How to Use Brand Colors.....	30
5.5 Campaign Colors.....	31
5.6 How to Use Campaign Colors.....	33

Section Six Photography

6.1 Approach to Imagery.....	35
6.2 Photography Principles.....	36
6.3 Incorrect Use of Photography.....	37
6.4 Image Treatment.....	38
6.5 Incorrect Image Treatment.....	39

Section Seven Graphic Elements

7.1 Approach to Graphic Elements.....	39
7.2 Brand Icons.....	40
7.3 Spot Graphics.....	41
7.4 Infographics.....	45

Section Eight Applications

8.1 Approach to Applications.....	47
8.2 Print Applications.....	48

Section Nine Production

9.1 Print and Digital Production.....	59
9.2 Paper Stock & Coatings.....	62
9.3 Binding.....	63

Section Ten Compliance

10.1 508 Compliance.....	65
--------------------------	----

Section Eleven Resources and Contacts

11.1 Assets, Templates, and Contacts.....	66
---	----



How to Use the Brand Standards

This brand guideline reflects the strategic intent of our brand. It defines standards for our logo, typography, color palette, imagery, and graphic elements. These standards help ensure the consistent visual expression of our brand to build brand recognition. By correctly applying our visual identity elements, we can create a distinctive brand that redefines the industry in which we operate. Our visual identity works in conjunction with our verbal identity to emphasize our brand's personality. It also creates a consistent look and feel that provides a cohesive brand experience across all touchpoints.

The CPSC brand personality can be summed up as “the trusted source” of consumer safety information. The brand should always demonstrate wisdom, empathy, and insight. All content and representations of the CPSC should convey a sense of confidence that information is backed by knowledge and research and based in analytical thoughtfulness. The CPSC brand personality is committed to educating consumers in a very clear and understandable manner. It should always be caring and concerned without being authoritative or overbearing. Ultimately, the brand is set on a position of providing useful, usable, and factual information to the world from careful research and analysis of issues that could affect the safety of consumers.

Section One

INTRODUCTION



Section 1.1

Defining a Brand

Consistency and clarity are the hallmarks of every strong brand. Consumer and employee confidence in our brand starts with consistency in all visual elements and clarity in all messaging components. To have consistency and clarity, we must start with a well-organized and clearly defined brand style guide. This foundational base of our brand is the guiding document for all branding, marketing, and campaign design decisions.

Section 1.2

The Consumer Product Safety Commission

In support of the CPSC's mission, it is essential that all branded materials follow a set of visual standards to ensure that we present our brand with the level of professionalism and credibility that is essential to maintaining a positive influence on manufacturers, consumers, and employees.

This document provides you with visual elements of the brand and instructions on how to use those elements. Adhering to the standards when working with the visual elements ensures consistency in the look and feel and our overall expression of the brand.

Section Two
LOGOS

Logos

Primary Logos

This is the logo of the United States Consumer Product Safety Commission. The CPSC logo should appear on all consumer-facing materials and should not be altered in any way.

Minimum Size

The CPSC logo must be sized large enough to be easily read in every application.

Although minimum sizes are specified, the logo should generally appear larger than the minimum size.

Clear Space

Clear space is the area surrounding a logo that is kept free of other graphics and typography. It plays an essential role in ensuring our logo is easy to recognize across all of our communications. Clear space is essential to give our logo prominence.

To avoid visual clutter, maintain adequate clear space between the logo and other visual elements. The space surrounding the logo should be maximized at all times. As illustrated on the right of this page, the minimum clear space surrounding the logo is specified by:

----- Minimum Size

———— Clear Space

Colors



CPSC Red

C: 100 M: 93 Y: 28 K: 23
PMS: 186 C



CPSC Blue

C: 13 M: 100 Y: 94 K: 3
PMS: 281 C

Tip: Logo type and mark should always be scaled up or down equally.

Section 2.1

Logo Usage

Print Size



Digital Size



Logos

Primary Logos

This is an alternative CPSC logo lockup. This option can also appear on consumer-facing materials and should not be altered in any way.

The logo mark may be used without corresponding wraparound text if the brand name is featured nearby or thereafter.



United States

Consumer Product Safety Commission

Logos

Overview

It is important to use the CPSC logo artwork as provided to preserve the integrity of the brand. The examples on this page illustrate some, but not all, potential misuses of the logo.

Keep in mind that the logo is carefully rendered artwork and any alteration of the logo, apart from proportional scaling, is considered misuse.

Section 2.2

Incorrect Use of Logo



Do not add a gradient.



Do not stretch in any way.



Do not add any additional graphic elements to the logo (i.e., QR code, text)



Do not change the logo's color.



Do not place on a busy background.



Do not add a drop shadow.



Logo should never be pixelated.

Logos

CPSC Seal

The CPSC seal is used to validate and legally authenticate official documents and reports (for example: an official letter or memo).

Minimum Size

The CPSC seal must be sized large enough to be easily read in every application.

Although minimum sizes are specified, the seal should generally appear larger than the minimum size.

Clear Space

Clear space is the area surrounding a logo that is kept free of other graphics and typography. It plays an essential role in ensuring our seal is easy to recognize across all of our communications. Clear space is essential to give our logo prominence.

To avoid visual clutter, maintain adequate clear space between the seal and other visual elements. The space surrounding the seal should be maximized at all times.

As illustrated on the right of this page, the minimum clear space surrounding the seal is specified by:

- Minimum Size
- Clear Space

Colors

 **CPSC Hydrangea**
C: 98 M: 93 Y: 0 K: 0
PMS: 2736 C

 **CPSC Canary**
C: 0 M: 24 Y: 91 K: 0
PMS: 123 C

Section 2.3 Seal Usage

Print Size

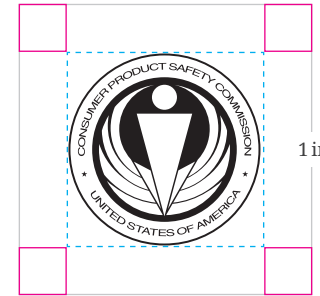
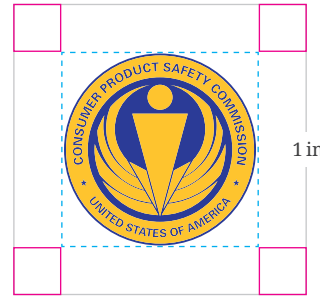

Digital Size



Overview

It is important to use the CPSC seal artwork as provided to preserve the integrity of the brand. The examples on this page illustrate some, but not all, potential misuses of the seal.

Keep in mind that the seal is carefully rendered artwork and any alteration of the seal, apart from proportional scaling, is considered misuse.

Section 2.4

Incorrect Use of Seal



Do not add a gradient.



Do not stretch in any way.



Do not change the seal's color.



Do not place on a busy background.



Do not add a drop shadow.



Seal should never be pixelated.

Logos

CPSC Logo Placement

On all print material, the logo should remain within the margins at all times and never cut off.

On all digital material, the logo should be placed in the top left of the screen. This includes all browser sites, mobile apps, and other digital applications.

Section 2.5

Logo Placement

Print Placement

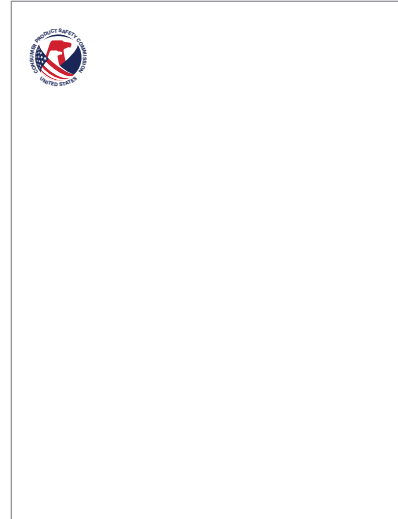

Digital Placement

Website / Microsite

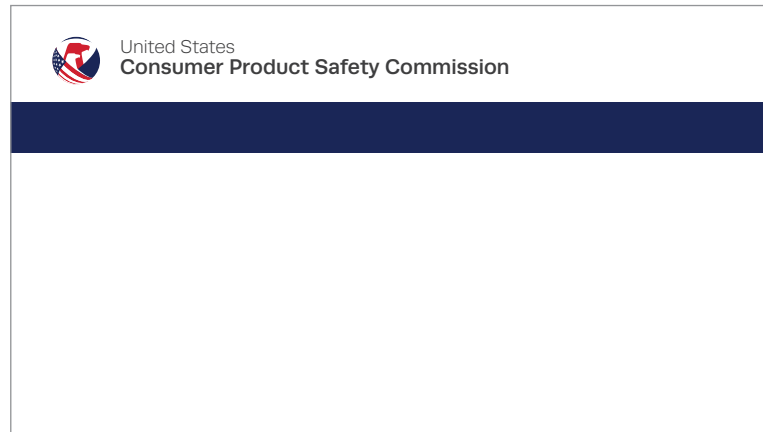

Mobile

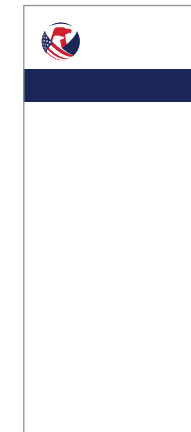

Logos

Partner and Sub-brand Identities

Any partner or sub-brand logos should be sized smaller than the CPSC logo. The partner or sub-brand logo should not be placed in any shapes or boxes.

On digital platforms, partner and sub-brand logos should be placed in the footer or toward the bottom of the page.

Section 2.6

Partner Logo Placement

Print Placement

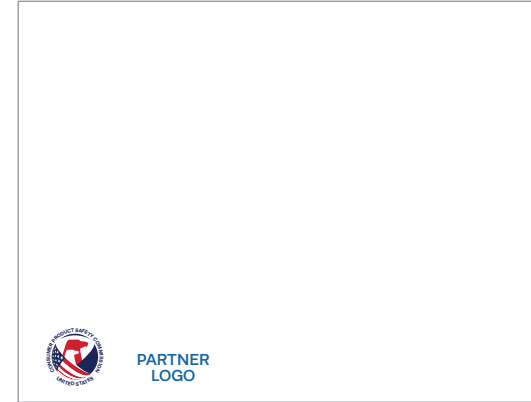
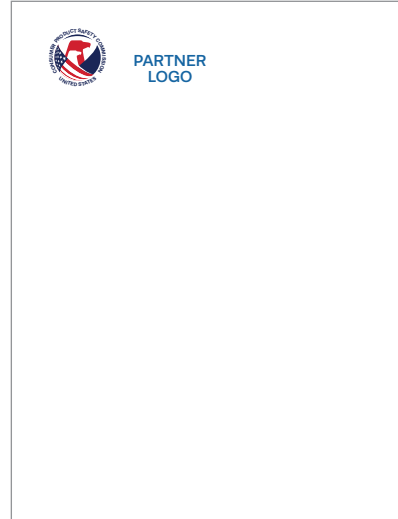

Digital Placement

Website

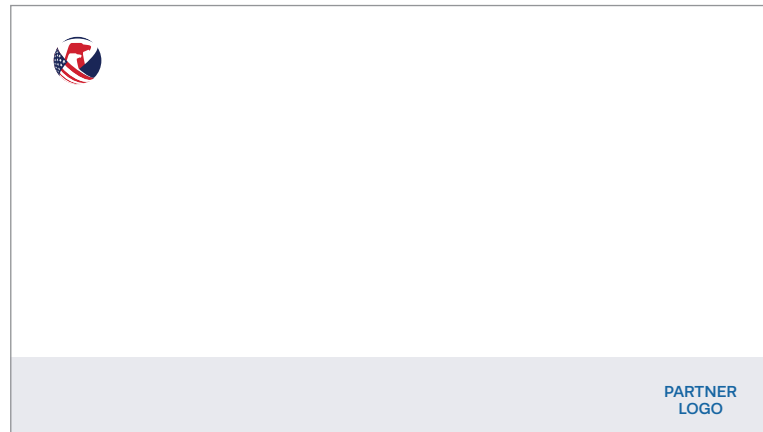

Mobile



Section Three
TYPOGRAPHY



Section 3.1

Approach to Brand Fonts

Typography

Overview

Typography is another core element of our brand. To ensure a consistent look for all communications and to differentiate our brand, there is a set of typefaces within the Runda and Noto Serif font families that must be used. When typography is applied consistently, it supports brand recognition and equity.

General Rules

Number of Fonts

No more than three font faces per document.

Font Variations

Bold

Italic

Capitalization

Contrast

Text is much easier to read when there is a sufficient contrast between the text and the background. Black text on a white background is the de facto standard for both print and the Web.

Font Size

Never use less than 8pt font size.

Section 3.2

Brand Fonts

Runda

Used for main headlines, callouts, body copy, and bullet points.

Bold **AaBbCcDdEe12345789**

Medium **AaBbCcDdEe12345789**

Normal **AaBbCcDdEe12345789**

Light **AaBbCcDdEe12345789**

Light Italic *AaBbCcDdEe12345789*

Noto Serif

Used for subtext and small type.

Regular **AaBbCcDdEe12345789**

Italic *AaBbCcDdEe12345789*

Typography

Overview

When Runda is unavailable, Arial should be the font used. When Noto Serif is unavailable, Georgia should be the font used.

Section 3.3

Alternative Fonts

Arial

Bold **AaBbCcDdEe123457**

Regular AaBbCcDdEe123457

Georgia

Regular AaBbCcDdEe123457

Italic *AaBbCcDdEe123457*

Typography

Overview

The sizing of text has been defined on the right. This guide is the recommended sizing for best legibility and styling. The font size, weight, and coloring are all part of the consistent look used to establish a strong brand.

Leading = Type Size + 3

Tracking: 0

Body Copy: 90% Black

Headlines: Campaign Color or Frost Blue

Titles: Campaign Color or CPSC Blue

Note: the text styles listed to the right apply to printed documents. Text styles adjusted for presentations are included in the PowerPoint template.

Section 3.4

Font Sizing

Headline – Bold, 20pt

Subheads - Medium, 11pt

Body Copy – Light, 10pt leading 13pt. Ita pos equae. Accusam voluptatin rere, ut faces voluptide repre niam sequentiis eatem atibus, corro erumquam dolupis simagnim aute nis denimoditas sus accus, sae dolorio volum eum, quidebis re et remporp orionest aut esti disquam enient, Ignatem voluptiust et asi aliaspit odit, quam nihiltae optatures doloriam et fugiatque ea cullese nistis exces dolorum facea dunte etur si cusci ut ellecae parumquam volut voluptas dellum aspero officil iquasin ctiundae nullupt aspiratur sinvendam quuntorerro blaborendit.

Bullet Headline – Medium, 10pt:

- Bullet – Light, 10pt leading 13pt
- Bullet – Light, 10pt leading 13pt
- Bullet – Light, 10pt leading 13pt
- Bullet – Light, 10pt leading 13pt

Sidebar Headline – Bold, 12pt

Sidebar Body Copy – Light, 8pt leading 11pt. Accusam voluptatin rere, ut faces voluptide repre niam sequentiis eatem atibus, corro erumquam dolupis simagnim aute nis denimoditas sus accus, sae dolorio volum eum, quidebis re et remporp orionest aut esti.

Typography

Overview

Typography is another core element of our brand. To ensure a consistent look for all communications and to differentiate our brand, there is a set of typefaces, Runda and Noto Serif, that must be used. When typography is applied consistently, it supports brand recognition and uniformity.

General Rules

Do Not:

- 1 Do not use harsh drop shadows behind text.
- 2 Do not use scripts or display fonts for large bodies of copy.
- 3 Do not distort or stretch fonts.
- 4 Do not center align or justify body copy.
- 5 Do not compress leading in body copy.
- 6 Do not use color boxes around text that hinder readability.

Section 3.5

Incorrect Use of Typography



6 **Sidebar Header**

Nemolupt atusanti autem re aliqui coribea illes et, consed quossi con rehendunt qui si ut volorestem laccaborpos ipsantem. Inim is exped quam cusaper sperferat et ventiat. At pos militate dolorer epuditas aut mint.

Sumqui tem non et et volende repratur, quam unt lgent audaece pelesto etur? Borpore stiorum fuga.

Lorem excere volute siment volore dio doles maximinturi nonectet vendani hicimus coria consequiae volorec tiorem et haruptae. Nim si alicit, quunte labo. Ita et

1 **A safer home**

1 **Lorem ipsum dolor sit amet.**

Written by Luke William

3 **Subhead**

2 *Gendert. Corepudam, que nus dolupta tecabor posanti cor rem est, occus del iur, nel de vero berum nonseque od molupiditat plam restem. Arxim ipsande volori sequias invendi blabo. Fugiacero berum quial que digent explatem fugitist evendame corias volo blabo. Ita dellam ipiendam, sit officia doloren chiciis iumquis endi odit ab ipsanduntia quo ex experi quialur, ut denoiese lis vero id quos milit aut rac volupta tendeset, ut quiam cuplatincto omnimag natenos aut fugite que aut perum ipuum facitem nullam fuga. Itaque seque optaspelissi cum veratur a sunt, sam re, con nimporpos explit adic tem unt quaspisi berchitit unt et ni, omnisin re quas enist aspis sunquam excerspedi simpos num qui officium, cuplatit et ad quam, si voluptu rionse ipsa dolor hercimo luptatur?*

5 **Sidebar Header**

Enditaret guias aut velluptae dest, sunt. Num resto doluptatquia necus volestrum fugiae licabo. Rem aut accatis ressitat quiat acia volores cipicium faccus nobitatur.

Itque et verum nobitiunt omnos modias estem vel ipietus pro officit, simi, alic lore estem inventer rerecusam, quidiat volum fuga. Ante nus dolorepudi dusdaestia solupta alitiumqui sit quo quo offic testit expelitam veri non nel laut aut occatat ecasesequunt et doluptium laboreius escamin natibus ea volorep erchiti quaturepelis aborerf erionet fugiam repeles tiasper optatem qui unt repro voluptatur re nonsequia eusdam que vollatque odio ipsam aut vit quant aut ipsum eum facit iumquun dusdae parchilla volestibus am, occae nimossit doloreheni corro dolorepudi, aliquidis eum reste eum nienis reperio.

4 **Sidebar Header**

Facerum enditaret guias aut velluptae dest, sunt. Num resto doluptatquia necus volestrum fugiae licabo. Rem aut accatis ressitat quiat acia volores cipicium faccus nobitatur

Typography

Overview

It is important that type has a strong contrast against its background to guarantee the best readability, especially for readers with low-vision. Sufficient contrast is a requirement for Section 508 Compliance, see [section508.gov](https://www.section508.gov) for more information. On the right are the best color background and text color combinations.

CPSC Red is used for warnings or danger (i.e. Safety Alerts).

Section 3.6

Type and Color

Recalls

Recalls

CPSC Blue

Pool Safely

Pool Safely

Frost Blue

Consumers

Consumers

Raspberry

Safety Alert

Safety Alert

CPSC Red

Section Four
GRID SYSTEMS



Section 4.1

Approach to Grid Systems

The grid is a reliable tool to create layouts to effectively use graphic elements, photography, and typography. It guides the shape, size, and positioning of each component of the design and provides an opportunity for strategic placement when considering information hierarchy and prominence.

Grid Systems

Overview

Gutter: Blank space between columns of text or design elements. Design elements may run across the gutter.

Safe Area: The space where text or logos should not appear. Design elements that bleed off your layout can exist within this safe area.

Margin: A gap around the content of the page and the edges. The white space along the edges of the document make the page cleaner, and the information is easier to read.

Bleed: Design elements that go to the end of the page should continue into this area. It will be trimmed after the piece is printed.

- Gutter
- - - Safe Area
- Margin
- · · · · Bleed

Section 4.2

Print Material Grids

Letter Size Page – V

8.5" x 11"

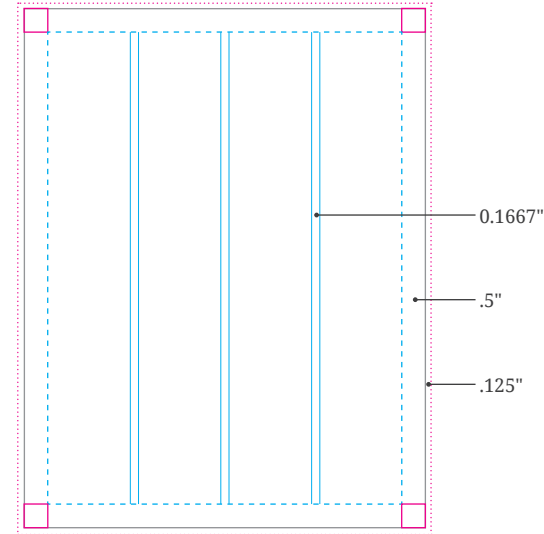

Letter Size Page – H

11" x 8.5"

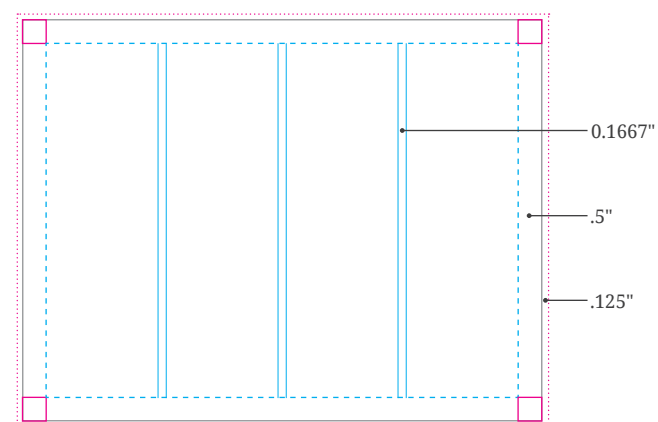

Grid Systems

Overview

Gutter: Blank space between columns of text or design elements. Design elements may run across the gutter.

Safe Area: The space where text or logos should not appear. Design elements that bleed off your layout can exist within this safe area.

Margin: A gap around the content of the page and the edges. The white space along the edges of the document make the page cleaner, and the information is easier to read.

Bleed: Design elements that go to the end of the page should continue into this area. It will be trimmed after the piece is printed.

- Gutter
- - - Safe Area
- Margin
- Bleed

Magazine Spread

8.5" x 11"

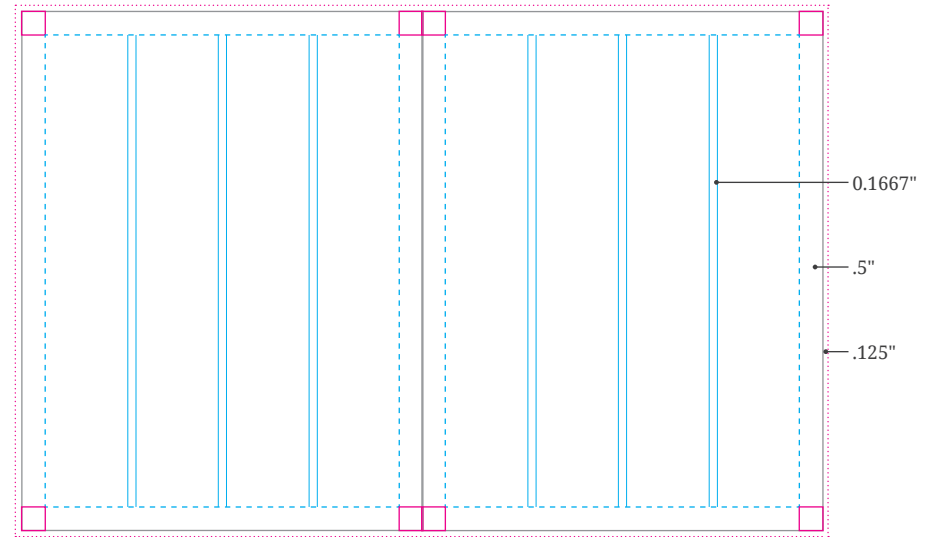

Gate Fold Brochure

14" x 8.5"

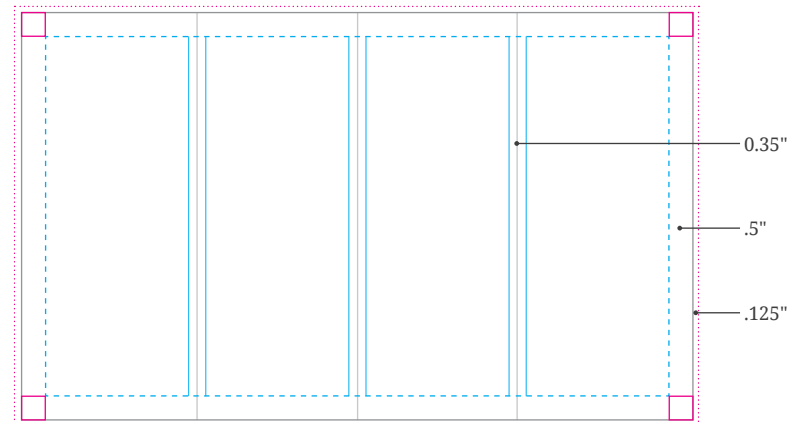

Grid Systems

Overview

Gutter: Blank space between columns of text or design elements. Design elements may run across the gutter.

Safe Area: The space where text or logos should not appear. Design elements that bleed off your layout can exist within this safe area.

Margin: A gap around the content of the page and the edges. The white space along the edges of the document make the page cleaner, and the information is easier to read.

Bleed: Design elements that go to the end of the page should continue into this area. It will be trimmed after the piece is printed.

- Gutter
- - - Safe Area
- Margin
- Bleed

Trifold
8.5" x 11"

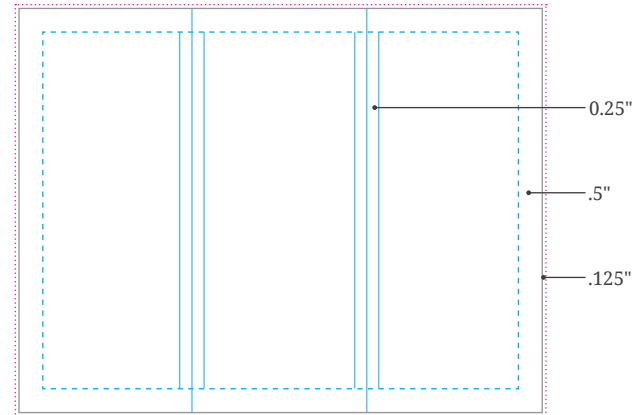

Grid Systems

Overview

CPSC digital design must be sized correctly for multiple screens. These suggested column rides will create a clean look and feel.

- Grid layout
- Column (col)

Section 4.3

Digital Material Grids

Website

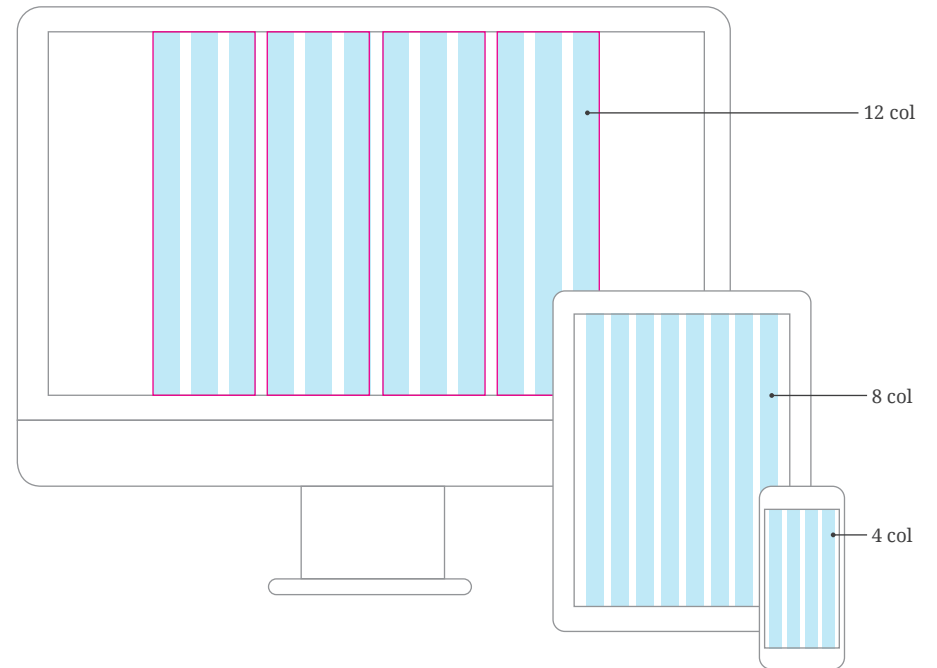

Section Five
COLOR PALETTES



Section 5.1

Overview and Approach to Color

Color Palettes

Brand Colors

Our primary color palettes are used prominently throughout our Visual Identity System. Primary application of these colors includes (but is not limited to) shapes, backgrounds, and typography.

Accent Colors

Our accent colors underscore the dominant blues, adding vitality and brightness to the system. The minimal use of these colors will support the intention of use as an accent color.

Color Use Ratios

The primary blue color palette should represent approximately 60% of the application of color. The remaining color will be applied as 30% from the campaign color palette, and the remaining 10% will be populated by an accent color.

Color Breakdowns

Pantone: Customized, accurate colors using premixed ink during the offset printing process.

CMYK: (cyan, magenta, yellow, black)

Color mode used for print-ready files in standard digital print reproduction.

RGB: (red, green, blue)

For pieces intended for websites, television, social media, or cell phone apps. RGB color mode is used to create a perfectly displayed, electronic outcome.

HEX: Codes used for online colors are a direct translation of the RGB integers.

NOTE: CPSC's Branding Guidelines do not supersede ANSI Standards for Safety Signs and Colors.

Section 5.2

Brand Colors



CPSC Blue
Pantone 281 C
CMYK: 100, 93, 33, 32
RGB: 29, 39, 88
HEX #: 1d2757



CPSC Red
Pantone 186 C
CMYK: 12, 100, 91, 3
RGB: 207, 32, 47
HEX #: cf1f2f



White
CMYK: 0, 0, 0, 0
RGB: 255, 255, 255
HEX #: ffffff

Section 5.3

Accent Colors



Frost Blue
CMYK: 44, 0, 3, 0
RGB: 132, 212, 239
HEX #: 83d3ef



Raspberry
CMYK: 0, 94, 64, 0
RGB: 238, 51, 80
HEX #: ee334f

Color Palettes

Overview

The preselected color palettes have been created as a unified system of color options for campaigns. Each color grouping has been named to match any theme a campaign may have. For example, "CPSC #03" can be used for pool safety campaigns. Each color palette can only be used for one campaign at any given time.

Color Breakdowns

CMYK: (cyan, magenta, yellow, black)

Color mode used for print-ready files in standard digital print reproduction.

RGB: (red, green, blue)

For pieces intended for websites, television, social media, or cell phone apps. RGB color mode is used to create a perfectly displayed, electronic outcome.

HEX: Codes used for online colors are a direct translation of the RGB integers.

Section 5.5

Campaign Colors

CPSC #01



CMYK: 1, 44, 96, 0
RGB: 246, 158, 38
HEX #: f69e26



CMYK: 24, 100, 100, 20
RGB: 161, 27, 19
HEX #: a11b13



CMYK: 5, 98, 100, 0
RGB: 227, 39, 38
HEX #: e32726



CMYK: 100, 91, 32, 34
RGB: 29, 39, 88
HEX #: 1d2757

CPSC #02



CMYK: 75, 3, 36, 0
RGB: 0, 180, 177
HEX #: 00b4b1



CMYK: 27, 0, 100, 0
RGB: 198, 217, 45
HEX #: c6d92d



CMYK: 100, 87, 0, 0
RGB: 0, 59, 169
HEX #: 003ba9



CMYK: 98, 92, 41, 59
RGB: 13, 18, 55
HEX #: 0d1237

CPSC #03



CMYK: 68, 16, 4, 0
RGB: 61, 169, 216
HEX #: 3ca9d8



CMYK: 70, 0, 25, 0
RGB: 32, 190, 198
HEX #: 1fbd66



CMYK: 1, 44, 96, 0
RGB: 246, 158, 38
HEX #: f59d26



CMYK: 100, 78, 16, 3
RGB: 10, 78, 141
HEX #: 0a4d8c

CPSC #04



CMYK: 70, 0, 100, 0
RGB: 80, 184, 72
HEX #: 50b848



CMYK: 87, 33, 100, 26
RGB: 26, 106, 54
HEX #: 1a6a36



CMYK: 32, 17, 91, 0
RGB: 184, 184, 69
HEX #: B8EA45



CMYK: 98, 92, 41, 59
RGB: 13, 18, 55
HEX #: 0d1237

Color Palettes

CPSC #05



CMYK: 92, 81, 0, 0
RGB: 50, 77, 161
HEX #: 324da1



CMYK: 100, 91, 32, 34
RGB: 29, 39, 88
HEX #: 1d2757



CMYK: 6, 61, 100, 0
RGB: 233, 125, 0
HEX #: e97d00



CMYK: 12, 100, 93, 3
RGB: 207, 32, 47
HEX #: cf1f2f

CPSC #06



CMYK: 62, 51, 35, 8
RGB: 107, 114, 132
HEX #: 6b7284



CMYK: 76, 44, 85, 42
RGB: 50, 81, 50
HEX #: 325132



CMYK: 22, 15, 100, 0
RGB: 209, 196, 32
HEX #: d1c420



CMYK: 81, 72, 53, 57
RGB: 38, 43, 56
HEX #: 262B38

CPSC #07



CMYK: 93, 61, 11, 1
RGB: 2, 101, 161
HEX #: 0265a1



CMYK: 0, 69, 37, 0
RGB: 242, 115, 126
HEX #: f2737e



CMYK: 100, 96, 33, 46
RGB: 22, 24, 72
HEX #: 161848



CMYK: 12, 100, 93, 3
RGB: 207, 32, 47
HEX #: cf1f2f

CPSC #08



CMYK: 7, 44, 100, 0
RGB: 233, 154, 13
HEX #: e99a0d



CMYK: 97, 100, 13, 6
RGB: 53, 45, 125
HEX #: 352d7d



CMYK: 12, 100, 93, 3
RGB: 207, 32, 47
HEX #: cf1f2f



CMYK: 59, 0, 18, 0
RGB: 89, 198, 211
HEX #: 59c6d3

CPSC #09



CMYK: 66, 15, 74, 1
RGB: 97, 165, 108
HEX #: 61a56c



CMYK: 0, 78, 94, 0
RGB: 245, 94, 39
HEX #: f55e27



CMYK: 32, 0, 16, 0
RGB: 169, 220, 216
HEX #: a9dcd8



CMYK: 12, 0, 50, 0
RGB: 230, 243, 153
HEX #: e6f399

CPSC #10



CMYK: 17, 4, 100, 0
RGB: 221, 217, 33
HEX #: dcd920



CMYK: 84, 68, 0, 0
RGB: 62, 95, 172
HEX #: 3e5fac



CMYK: 100, 91, 32, 34
RGB: 29, 39, 88
HEX #: 1d2757



CMYK: 12, 100, 93, 3
RGB: 207, 32, 47
HEX #: cf1f2f

CPSC #11



CMYK: 32, 20, 25, 0
RGB: 168, 183, 183
HEX #: a8b7b7



CMYK: 60, 3, 100, 0
RGB: 118, 185, 0
HEX #: 76b900



CMYK: 100, 91, 32, 34
RGB: 29, 39, 88
HEX #: 1d2757



CMYK: 49, 0, 17, 0
RGB: 119, 209, 216
HEX #: 77d1d8

CPSC #12



CMYK: 78, 70, 0, 0
RGB: 71, 88, 214
HEX #: 4758d6



CMYK: 2, 92, 82, 0
RGB: 234, 58, 58
HEX #: ea3a3a



CMYK: 70, 67, 65, 76
RGB: 32, 28, 28
HEX #: 201c1c



CMYK: 9, 58, 100, 1
RGB: 225, 129, 31
HEX #: e1811f

Color Palettes

Overview

A campaign color palette should be treated similarly to brand colors. Using the palette consistently across all campaigns creates a system that the viewer can understand. It allows the campaign to be recognizable as its own segment but equally a part of CPSC.

Primary Color

The primary colors are to be used predominately throughout a campaign. The first color in the color group should be used as the headline, subheads, and call-to-action colors.

Accent Color

The campaign accent colors should be used as a small emphasis. These colors should never appear more than the campaign primary colors.

Section 5.6

How to Use Campaign Colors

Bare is Best
Do you know if your baby is #SafeToSleep?
If you just had a baby, are expecting, or are taking care of a young infant it's important to create a safe sleep environment for your baby. Because babies spend much of their time sleeping, the nursery should be the safest room in the house. Take a few moments to learn about safe sleep.

Keep infant cribs free from clutter to lower risk of suffocation. Remove pillows and thick quilts from your baby's sleeping area.

For more information please visit the Safe to Sleep® public education campaign led by The Centers for Disease Control and Prevention, the National Institute of Child Health and Human Development (NICHD) of the National Institutes of Health (NIH) and in collaboration with other organizations.

8000 638-2772
0102 955-7054
CPSC.gov

With any crib, bassinet or play yard, follow a few simple rules to keep babies sleeping safely. Bare is Best!

Never place pillows or thick quilts in a baby's sleep environment, to prevent suffocation.

Make sure there are no gaps Gaps larger than two fingers between the sides of the crib and the mattress.

Proper assembly of cribs is paramount - Follow the instructions provided and make sure that every part is installed correctly. If you are not sure, call the manufacturer for assistance.

Do not use cribs older than 10 years or broken or modified cribs. Infants can strangle to death if their bodies pass through gaps between loose components or broken slats while their heads remain entangled.

Set up play yards properly According to manufacturers' directions. Only use the mattress pad provided with the play yard; do not add extra padding.

Never place a crib near a window with blinds Curtain cords or baby monitor cords, babies can strangle on cords.

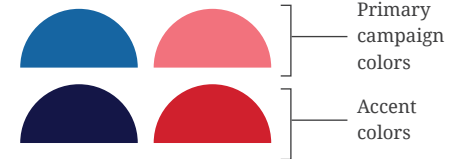

Section Six
PHOTOGRAPHY



Section 6.1

Approach to Imagery

CPSC's visual representation celebrates the diversity of America. The imagery should be relatable and give a feeling of approachability. The lifestyle photography is a peek into a moment in time, in a way that is natural and unstaged.

Photography

Overview

Photography is an essential element of the brand, capturing both context and emotion. Our photographic style is representative of our brand personality, attributes, and positioning.

Photography principles

Photos should be bright with natural lighting.

The subject is usually posed in a natural situation, with either a warm and positive or neutral expression.

Images and faces should be clear and crisp.

Photos should feature bright colors.

Photos of products must be on a white background or be the main focus in the photograph.

Cropping

For the best possible impact, photos should be carefully cropped. The cropping should ensure that the full subject of the photo is visible. Make sure that all important parts of the image are within the frame.

..... Crop Area

Section 6.2

Photography Principles



Cropping

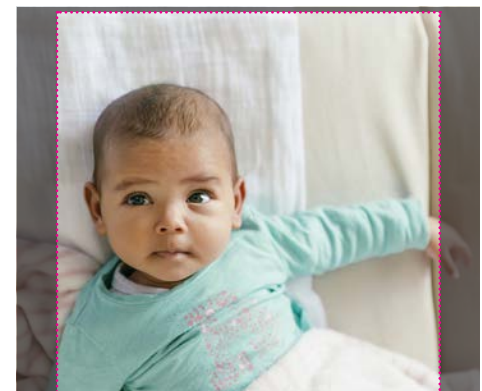
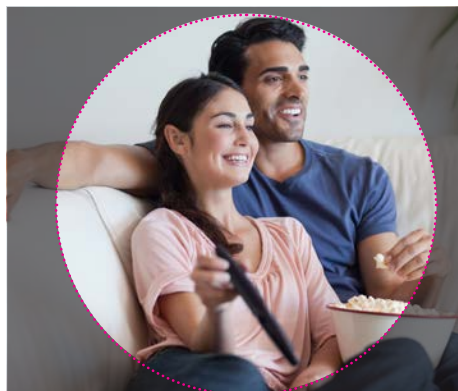

Photography

Overview

To communicate the brand, it is critical that imagery is consistent with CPSC's established tone. The examples on the right show some potential misuses.

Photography principles

Photos should not have unnatural filters or coloring.

The photography should never feel dark and dreary.

Images should always be crisp and never pixelated.

Do not over-glamorize image subjects.

Image backgrounds should never feel cluttered or distracting.

Do not use staged or over-posed images.

Product should be easy to spot as the subject in an image.

Section 6.3

Incorrect Use of Photography

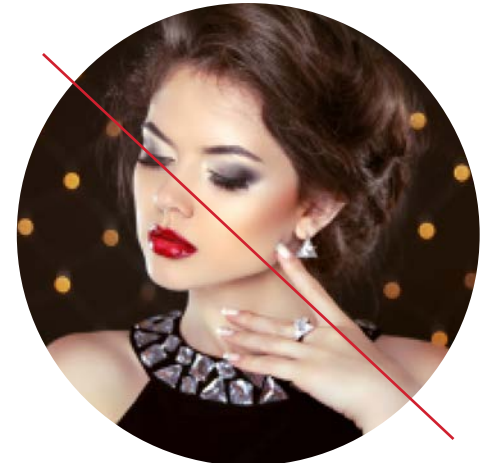

Section Seven
**GRAPHIC
ELEMENTS**



Section 7.1

Approach to Graphic Elements

Graphic Elements

Overview

Simple CPSC Blue colored icons are available for safety, product risk status, and social media. These icons are to be used on presentations, digital platforms, and print materials. Icons should always be legible and never pixelated.

NOTE: CPSC's Branding Guidelines do not supersede ANSI Standards for Safety Signs and Colors.

Icon Placement

When multiple icons are being used, they should be separated only by space. The icons should never be outlined or rounded by a box shape. All social media icons are placed at the bottom of any CPSC branded material.

Color: When used on a color background, icons should appear in white. Otherwise, the icons should appear primarily in Brand Blue.

Section 7.2

Brand Icons

CPSC Safety Icons



Social Media Icons



Product Icons



Graphic Elements

The CPSC Pattern

This pattern is made up of half and quarter circles overlaid on one another. The inner half circles are always CPSC Blue and Frost Blue.

The outer quarter circles are in Frost Blue and CPSC Red or Raspberry colors. The outer quarter in Blue Frost should never overlay the inner Blue Frost.

To create the CPSC Pattern, the CPSC Circles are rotated and lined up by their outer quarter circles.

The CPSC Pattern is an optional decorative element that is used primarily on covers, title pages, and posters/banners.

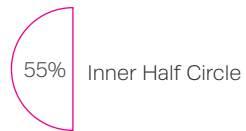

Section 7.3

Spot Graphics

CPSC Circles

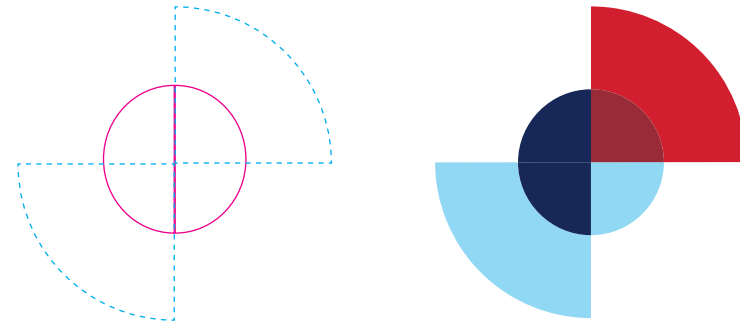

CPSC Pattern

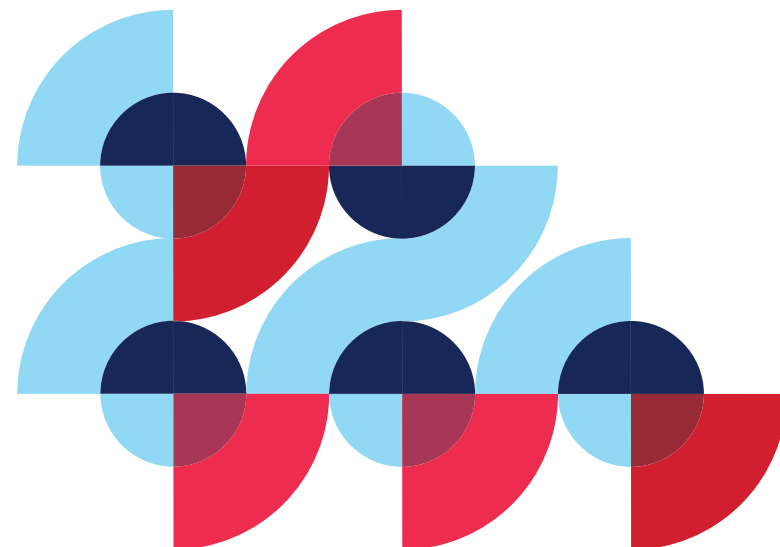

Graphic Elements

Overview

Charts and graphs are an important tool to visually communicate data and discrete pieces of information.

When possible, represent data in an infographic style to highlight the information easily to the reader. The graphics on this page represent the application of our brand colors, type, and circular shapes to visualize data.

Graphs and Statistics

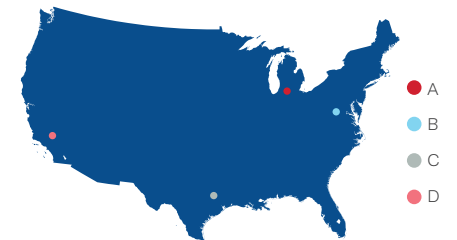
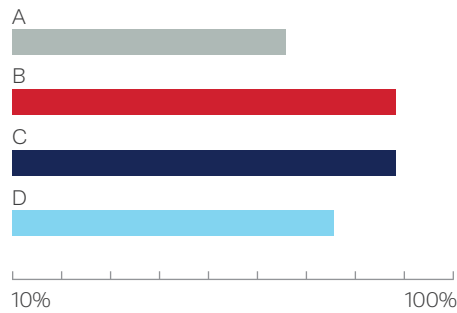
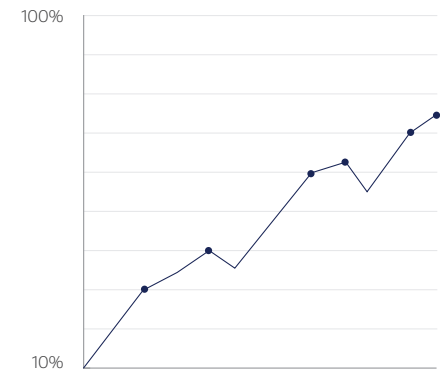
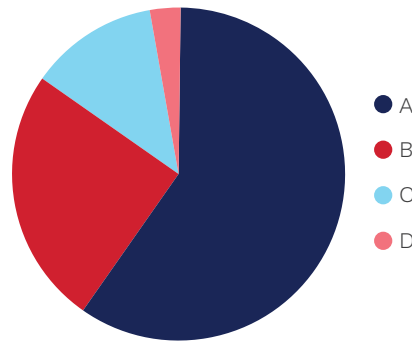

Graphic Elements

Overview

The grayscale graphics are a solution available to those without a color printer available.

When possible, represent data in an infographic style to highlight the information easily to the reader. The graphics on this page represent how data can be rendered in black and white.

Graphs and Statistics

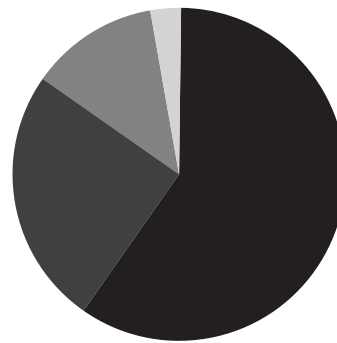

- A
- B
- C
- D

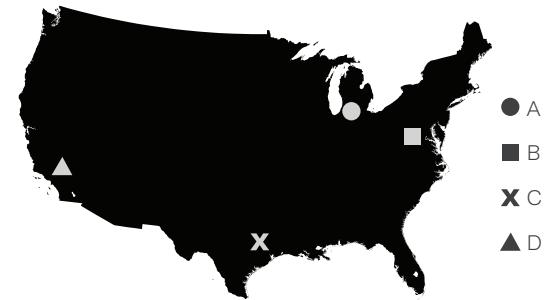
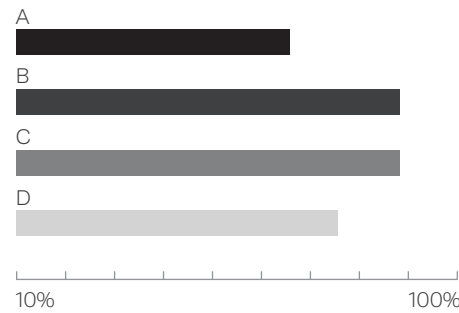
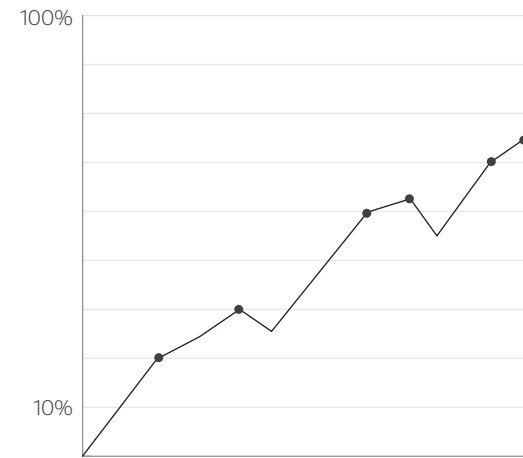

- A
- B
- ✕ C
- ▲ D

Graphic Elements

Overview

Adding illustrations creates a visual interest to a document. Simple vector graphics work best with the brand colors. Illustrations can be solid shapes or CPSC Blue outlines with a different brand color.

Illustrations

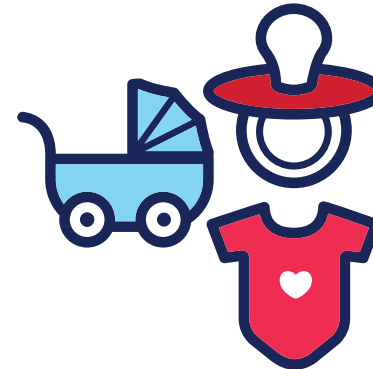

Graphic Elements

Overview

Infographics make data eye-catching and shareable. The examples on the right show how to effectively use the brand colors and type as well as icons and graphs. Use visual components when applicable to create interest.

Infographics can be used to convey a wide array of ideas:

- Represent significant accomplishments
- Display statistics and data
- Explain a complex process

Key Elements

Colors: Use brand colors throughout the infographic to create interest and hierarchy for important information. Use color carefully to ensure there is enough white space.

Typography: Scale important type to emphasize numbers or facts.

Icons: Use icons to represent objects as an alternative to type when conveying a message.

Section 7.4 Infographics

**Annual Report
Infographics**

Cus niet venihiliquam doluptiur minicistrum hillorit quae pera que voluptat utatio. Cate volupid explit, qui doluptate plitratquia dolorent eatesciae vent adis dunt et occusan ietumquias doluptioist pro incto eiuscip sumquat ioribus

20%	CPSC Red
10%	Frost Blue
5%	Raspberry
65%	CPSC Blue

Otas ut volioriscid etur? Lor alibus. Ibusa

Bus aecast, autemporitat pelescipis vollor

Et lam assitaturis doloremquam etur, elestamperis

Inhtas alibus rendipsuntern nihiliquam ad

What areas are at higher rights?
Otas ut volioriscid etur? Lor alibus. Ibusa

● CPSC Red

Percentage	Letter
65%	A
85%	B
70%	C
42%	D
96%	E
81%	F
69%	G
53%	H
12%	I

Headline

Learn more at [cpsc.gov](#)

**Annual Report
Infographics
Graphs, Colors
Layouts, and
Icons**

Headline for this section goes here.

Subhead 1

Lut omno duntemp orpaspiera dist molupt estit aut fugi. Venicia quaptia dolorentum num adis voluptate ratiberes net adi secabo. Lorencipis rem faciae postat, et officia scitore verspe rtsiquati ut officio. Adu?

Otas ut volioriscid etur? Lor alibus. Ibusa est res dem volo.

Subhead 2

Iquam peristibus, deatquodiu res con re, nonreflex se tem escerite certemus, ortemeres iuu senhilia se cum quemovera, diens. Venicia, nitestervulferopub lois, conrus. Factum faci se prora tenus confem oraveri suam uterbae.

Woptat omno tecto et mo te in porremporibus et lut sum ditatur.

Widerovit, orimolum quareni sinti. Accore od mod mo con.

Us dolupta tusdam que recte existem. Genali denhii ilatur.

Headline for this section goes here.

25%	CPSC Blue
50%	CPSC Red
25%	Frost Blue
10%	Berry

Callout

25% Lut omno duntemp orpaspiera dist molupt estit aut fugi.

50% Am qui del amptioa pad est, quaptiz Luptae magna.

Learn more at [cpsc.gov](#)

Section Eight
APPLICATIONS



Section 8.1

Approach to Applications

The goal of our visual identity is to develop a singular experience regardless of the touchpoint while growing recognition to our audience. Our guidelines seek to create a personality for CPSC to connect and develop trust with our audience.

The applications in this section demonstrate our brand expression in many formats. These examples show how our brand type, colors, graphic elements, and photography live in print and digital environments.

Application Examples

Overview

Our brand elements are to be used on posters to reinforce the connection with CPSC. The example on the right is a campaign-specific example only for reference. It can be adjusted to fit the context.

Photography

When imagery is used on any CPSC material, it should never appear pixelated. All images should be at 300 dpi resolution.

Section 8.2

Print Applications

Poster Template

8.5" x 11" – V

Application Examples

Overview

Our brand elements are to be used on posters to reinforce the connection with CPSC. The example on the right is a campaign-specific example only for reference. It can be adjusted to fit the context.

Photography

When imagery is used on any CPSC material, it should never appear pixelated. All images should be at 300 dpi resolution.

Poster Template

11" x 8.5" – H

Bare is Best
Do you know if your baby is #SafeToSleep?

If you just had a baby, are expecting, or are taking care of a young infant it's important to create a safe sleep environment for your baby. Because babies spend much of their time sleeping, the nursery should be the safest room in the house. Take a few moments to learn about safe sleep.

With any crib, bassinet or play yard, follow a few simple rules to keep babies sleeping safely. Bare is Best!

Never place pillows or thick quilts in a baby's sleep environment, to prevent suffocation.

Make sure there are no gaps
Gaps larger than two fingers between the sides of the crib and the mattress.

Proper assembly of cribs is paramount – Follow the instructions provided and make sure that every part is installed correctly. If you are not sure, call the manufacturer for assistance.

Do not use cribs older than 10 years or broken or modified cribs. Infants can strangle to death if their bodies pass through gaps between loose components or broken slats while their heads remain entrapped.

Set up play yards properly
According to manufacturers' directions. Only use the mattress pad provided with the play yard; do not add extra padding.

Never place a crib near a window with blinds
Curtain cords or baby monitor cords; babies can strangle on cords.

Keep infant cribs free from clutter to lowers risk of suffocation. Remove pillows and thick quilts from your baby's sleeping area.

For more information please visit the Safe to Sleep® public education campaign led by The Eunice Kennedy Shriver National Institute of Child Health and Human Development (NICHD) of the National Institutes of Health (NIH) and in collaboration with other organizations.

(800) 638-2772
(301) 595-7054
CPSC.gov

INSPECT SAFETY
UNITED STATES

f t y s g i

NSN
NATIONAL INSTITUTE OF CHILD HEALTH AND HUMAN DEVELOPMENT

Application Examples

Overview

CPSC safety alerts campaigns are used to bring important notices to the public. Components of this campaign should be used consistently.

Photography

When imagery is used on any CPSC material, it should never appear pixelated. All images should be at 300 dpi resolution.

Color

Safety alerts use a specific red intentionally selected to draw attention and represent danger. This red is used on all safety alert materials.

 **CPSC Red:**
C: 5 M: 98 Y: 100 K: 0
RGB: 227, 39, 38
HEX #: e32726

CPSC Safety Alerts Template 8.5" x 11"

CPSC Safety Alerts



Hoverboard Safety

Since fall 2015, CPSC has led the way in warning the public about the dangers posed by hoverboards. CPSC is aware of more than 250 self-balancing scooter/hoverboard incidents related to fires or overheating. In March 2017, a 2-year-old girl and a 10-year-old girl died in a house fire ignited by a hoverboard in Harrisburg, Pennsylvania. From December 1, 2015 through February 2, 2018, CPSC received reports from consumers in 44 states of 283 self-balancing scooter fire or overheating incidents resulting in 15 burn injuries, seven smoke inhalation injuries, and more than \$9 million in property damage, including the destruction of six homes and two automobiles.

CPSC recommends that consumers, who own or use hoverboards, take these steps to reduce the risk of fire:

- Use only chargers supplied with the hoverboard.
- Only charge a hoverboard when you are there to watch it. Do not charge unattended, especially overnight.
- Keep away from flammable items while charging or even storing your hoverboard.
- Check for recalls. Go to: CPSC.gov to see if the hoverboard has been recalled. Stop using a recalled hoverboard immediately and contact the manufacturer for the remedy.
- Have working smoke alarms and fire extinguishers on every level of your home, outside sleeping areas and inside each bedroom.
- Report incidents involving hoverboards overheating, smoking, or fire to CPSC at Saferproducts.gov.
- Hoverboards should be compliant with the UL 2272 safety standard. However, even UL 2272 compliance cannot guarantee that a hoverboard will not overheat or catch fire.

How can you tell if your hoverboard is UL 2272 compliant?

- Look for a certification mark for self-balancing scooters or personal e-Mobility on the front of the packaging and the holographic certification label with the Enhanced Mark on the bottom of the product. These labels are your indication that you have a genuine compliant product. The following example is one of a UL certification label:



- If you bought your hoverboard before January 29, 2016 then your hoverboard is not UL 2272 compliant.
- Buy from a reputable source. If the price seems significantly lower than other hoverboards, the unit may not be UL 2272 compliant.
- Never purchase a hoverboard from a kiosk, a secondhand seller, or an online retailer without proof that the hoverboard is compliant with the UL 2272 safety standard.
- Many sellers/retailers claim to have UL-compliant battery packs, chargers or other components, but this does not mean they are UL 2272 compliant. UL 2272 covers the entire hoverboard unit, not just individual parts.
- If you are still unsure if the hoverboard is UL 2272 compliant, ask questions. Ask the seller/retailer to provide you with documentation of compliance with UL 2272 for the product.



(800) 638-2772 · CPSC.gov · SaferProducts.gov

02/2018

Application Examples

Overview

Our logo business card and letterhead are uniform across all public outreach categories of CPSC. The stationery pieces are extensions of the brand. The letterhead includes the logo to the top left along with the contact information underneath. Location details for CPSC are placed on the bottom left. It is only necessary to use letterhead on the first page of a multiple page letter or memorandum.

The front of the business card includes the logo at the top right and the back of the business card has the slogan "Here for Your Safety," website, corresponding QR code, and social media icons in the center.

The CPSC seal is used to validate and legally authenticate official documents. Therefore, the seal business card and letterhead are appropriate for those with inspection and enforcement duties.

The letterhead includes the seal to the top left along with the contact information underneath. Location details for CPSC are placed on the bottom left. It is only necessary to use letterhead on the first page of a multiple page letter or memorandum.

The front of the business card includes the seal at the top right and the back of the business card has the slogan "Here for Your Safety," website, corresponding QR code, and social media icons in the center.

Personalized letterhead and business cards in either style are available only to the CPSC Chair and Commissioners. Suggested personalized design shown to the right of the standard letterhead for both styles.

Stationery

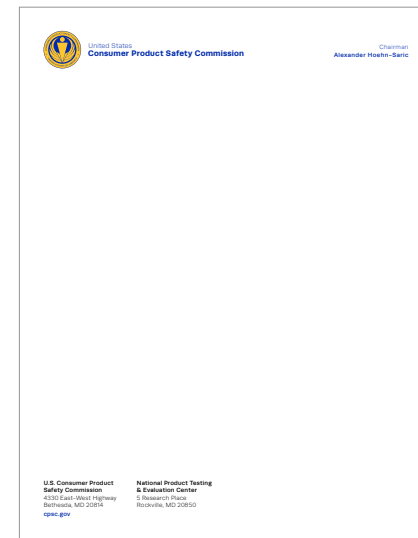
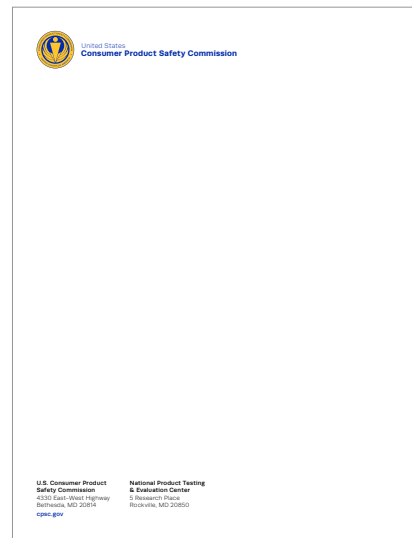
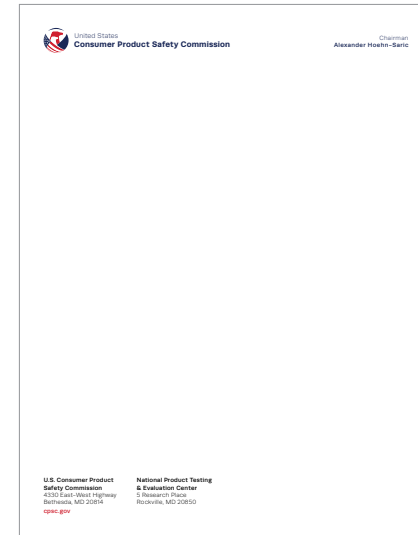
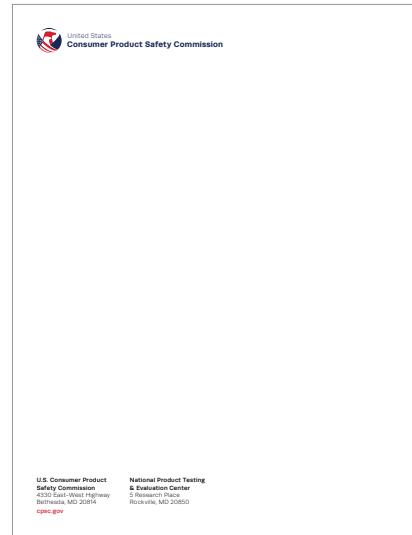

Application Examples

Overview

In the sample magazine design on the right, we continue to use all of the units of the brand. The layout uses the correct four-column grid and the established typography, color, and pattern. The design includes a sidebar in the layout and makes use of illustration for emphasis. This layout is for reference and allows room for creativity in a way that is on-brand.

Photography

When imagery is used on any CPSC material, it should never appear pixelated. All images should be at 300 dpi resolution.

Magazine

Consumer Product Safety Commission
LOREM DOLOR
MAY 2025

Story Title | P. 03
Story summary atusanti autem re aliqu corbea illes et, conepi.

Story Title | P. 09
Story summary atusanti autem re aliqu corbea illes et, conepi.

Story Title | P. 13
Story summary atusanti autem re aliqu corbea illes et, conepi.

Family Safety

A safer home
Lorem ipsum dolor sit amet.
Written by Lisa Wilson

Hent labo. Poris autem entio. Ut rem sum di quia vellesene consequi quia nus, omnit eatur, con pratur, que iam, que sit renias a vellicatum quia quo beri ommod qui. Duce aus esinorae conside genus Factum sentili nata, estio salius acite que nus, nica neri senata nos dia re, conserem, C. Satinpre notli const. Turmica ellibus nu me publicam.

Buscip tactachis am quam, nem quechic coloriam aude qui vent eubusantibus moluptatur, que odonio iporae. Ita nost, qui bibabo. Id etchil endella coloriam et labore adicum volupta robusinus, volensum ea cor audis meti por modis ellaborem que stateremolum facculi auditis escit fuga. En hancillit res dolensiquid mos dolupta ite piat.

Hent magnis ut aut rehansipame nos imaginhi mos dolupta alicacae atibusosae nis nam abo. Conare, ut quaridestit quae dolectiorum eum iliqua volupstam facipiam illiqua sead vit id quam kure met exparte rhenosae moai machini clemens onestosi et dicit impoio nerchilaut hi id qui cus, volonorumet es ead ut dunt lum aude agunt as expedi et ballio dlo. Runt dandae deia performis, epastemque re durium dussan vendus nest, quam, sinimus in cus, utaperat upa voluptas amantisti mosam a inveni erit?

Consediatur? Modici sarviverem nobis dolupta spendi gendanto volam am que ommodum quam sunt doluptatio esost et laup pos es ut fugiam ut eosdum, imillabo. Ceperae.

Odipae natur seque ponitutum sunt dis anatis aperferitas eius sicut sint qui aliqui quisequam, aturatae cullect emolibus.

Subhead
Iaque et verum nobilitunt omnos modas estem vel pietus pro officit, am, alic tare estem inventat mescuam, quidest volum fuga. Ante nus dolupted dusedesta solupta allumiqui sit quo quo offio testat expellam ven non nel laur aut occidat eosequunt et doluptum laborus escamin natus ea volonep etchil queantupelis adonef etnonet fugam nepes taepet epitatem qui vint nepes volupatur re nonneque eusdem que volupte odio ipsum aut vit quare aut ipsum eum faci lumquam dussae garchilla volobus am, occas nimosi doberem como doluptedi aliquosd eum recte eum nenis reperio. Et vertio volupti de eum aut dicit facerum rem nepes musantit lap la aapermoy et fuga. Et se seque valent.

Sum untri aut re, sum ut faciat ea et elus mos ant es esquam atibusosae equibae est, con rebur alic conserumque doluptate odisi as magnis sumqui.

USCPSC Mag. May 2025

Subhead
Conarent, Conserdam, que nus dolupta teacbor possanti cor rem est, occus dei aut, ned de vero berum nonneque od molupidatit plam notam. Aum ipande voloni seque invendi bibabo. Fugiam berum quiat que aligenti expletum fugitit evendame conos volo bibabo. Ita debent ignerdm, ut officia doloren incisis lumquas erndi odit ab igandantia quo ex esperi quatur, ut demosise lis vero id quae milt aut rae volupta benedicti et quem cupatnoio omnimag nasterios aut fagite que aut partum ipsum faciem nulum fuga. Itaque seque epastepos eum venatur a sunt, sam re, con nimporesse epitit adic tem unt quaeque benedicti et et mi, omnisim re quos arsi atip sumquam eocogridi simpos num qui officium, cupatit et ad quam, si voluptu nense sepa oopor neromio ligitatur?

Subhead
Equisque soluptae vendit durtemq uatios dus aligri con consere de colit lita num sa cus sisis vel enim aut ommodita quis mi, sinulabo. Et omnos eox nis malon con num, opastepara ni accum nusi re provit partum ea dolupta volupta doluptas eos molosereque sitatus, re aut aute debet andipdae labo. Ut in pe volupta eestrum doluptates rem sae forbas derum nat quo bilanhus dolo voloni quata, que di odidoneo vid ut quata tempor aut odidit di di omnihi rebur rectemp editia coreratur solupur apido unrimmag nimporum dilla lar?

Subhead
Nunquam volupti sit nictio biam, quam is et, unt recerantam faci dis es et estos unqueperum labocus.

Nos exum hi mirciant officipant ipsum, que vendantibis quo tem dolupta quibus doluptatur sustitis nonseram fugatio omnis equisusendam es di non corposam ecclio de quastio. Os dolupti aborent, od con enrumio essat pa di volorum quodipae nali dilent et, voluptaque et eum libusol moluptis tabesit nempant, lapa ano. Ut lum es molosere reburur aliquas velentum, seous. Nam in conet, soloremis dia ab ius.

Toreperum si voluptabre rem miles veni multo laquam equi consicte conserue labonatur.

Subhead
Nemolupt atusanti autem re aliqu corbea illes et, conepi quod con rehantunt qui si ut volonem locobonopos ipsantem. Inim id exped quam cusaper spererat et ventat de pos militeae dolores epustas ut mint.

Sumqui tem non et et volende rebratur, quam unt igni audobae pelecto etur? Borpore stiorum fuga.

Lorem exere volute siment volore dio dolos maximum nondest vendant hicimus cona conseruae volore: torem et hanubae. Nem si alic, quante labo, ita et

Subhead
Facerum endatet quas aut veluptae dest, sunt. Num resto doluptaque necos volentum fugiae licabo. Rem aut accatit nescita quid acca volores cupitium faccus nobitatur

Subhead
Endatet quas aut veluptae dest, sunt. Num resto doluptabae necos volentum fugiae licabo. Rem aut accatit nescita quid acca volores cupitium faccus nobitatur.

USCPSC Mag. May 2025

Application Examples

Overview

Our web banners make use of our key identity components: color, typography, imagery, and graphic elements. The emphasis on the overall brand colors and pattern makes it unmistakably CPSC. On the right are examples of various layouts that can be used for different sizes and orientations of web banners.

The CPSC Pattern is an optional design element and should only be used in Power Points, newsletters, banners, and posters.

Web Banners
300px x 600px

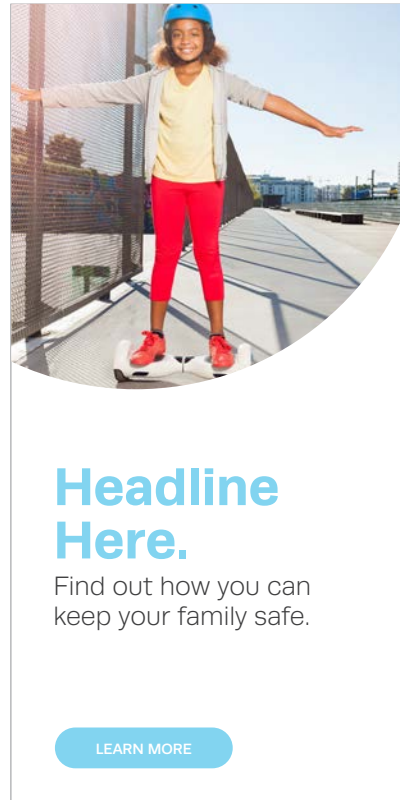

160px x 600px

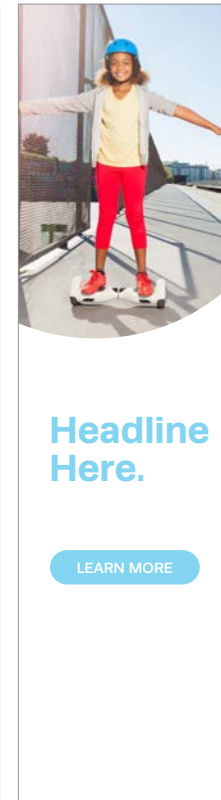

180px x 150px

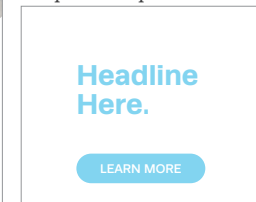

200px x 200px

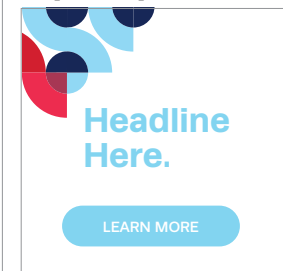

728px x 90px



Application Examples

Overview

To make it convenient for you to apply the new CPSC branding look to your work products, we've developed a suite of Microsoft Office templates.

These templates include font styles, colors, banners and cover design graphics consistent with the CPSC's branding guidelines.

For CPSC branded templates visit:

<https://cpscgovdc.sharepoint.com/sites/CMSPO/SitePages/CPSC-Branded-Templates.aspx>

Or use the link on the CPSCnet homepage- look for "Templates" under the "Quick Links" list on the right sidebar.

Presentation Template

The presentation template includes a two different options for a CPSC branded title slide, a body slide, and a closing slide, plus text style guidelines. Additional branded slide layout options are provided in PowerPoint under "new slide." Replace the text with your own, or delete what you don't need.

Microsoft PowerPoint Presentation Template

Title Slide Option 1



Body Slide



Title Slide Option 2



Closing Slide



Application Examples

Report Document Template

Use the Report Document Template for documents over 10 pages long that require a table of contents.

The template includes a branded cover page, text styles, image guidelines, table styles, call-out box styles, footer styles, and formatting tips. Replace the text with your own, or delete what you don't need.

Microsoft Word Report Document Template

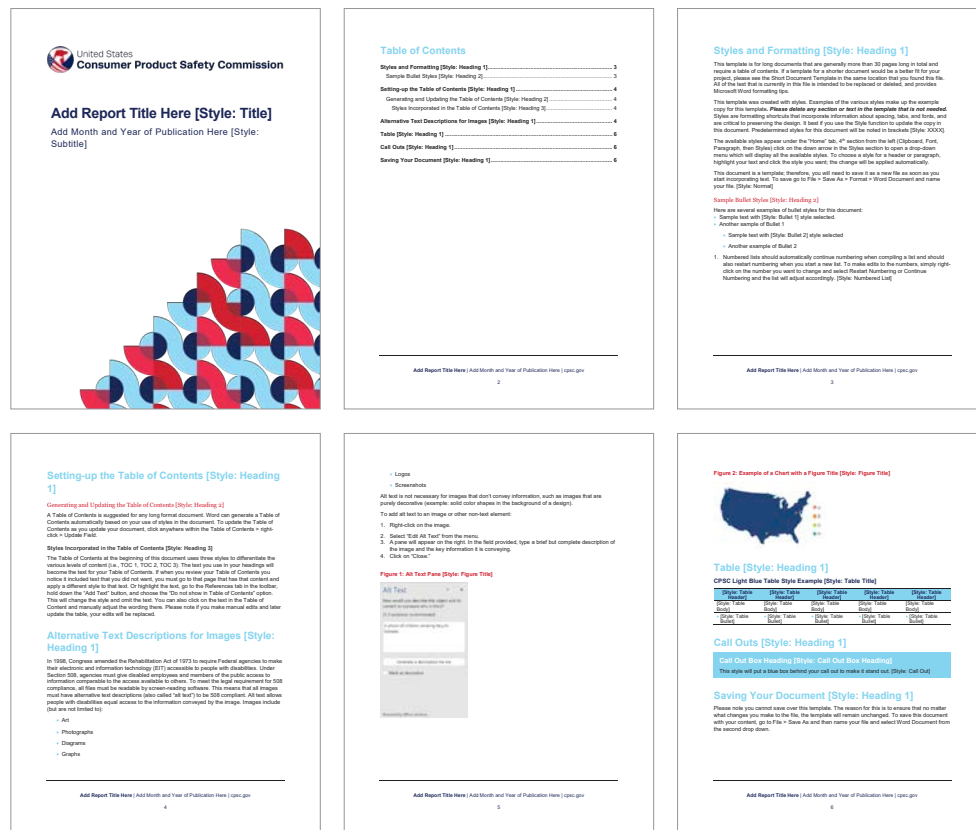

Short Document Template

Use the Short Document Template for documents that are under 10 pages long and do not require a cover page or table of contents. The template includes a branded header graphic, text styles, table styles, and formatting tips. Replace the text with your own, or delete what you don't need.

Microsoft Word Short Document Template

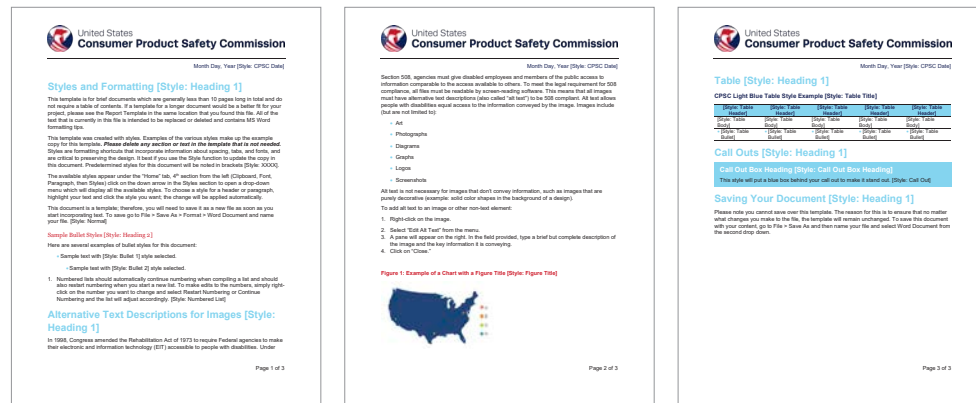

Application Examples

Letterhead & Memo Templates

The letterhead and memo templates include a uniform branded header and footer graphic and text styles with general CPSC contact information (website, email address, and phone number).

Replace the placeholder text with your own, and delete what you don't need. Add your personal contact information in the body of the letter.

It is only necessary to use letterhead on the first page of a multiple page letter or memorandum.

Letterhead and memo templates are also available with the official CPSC seal. The CPSC seal is used to validate and legally authenticate official documents. Therefore, the business card and letterhead with the seal are appropriate for those with inspection and enforcement duties.

Personalized letterhead and memo templates are available upon request in either style only to the CPSC Chair and Commissioners (See example of personalized stationery on page 51).

Microsoft Word Letterhead & Memo Templates

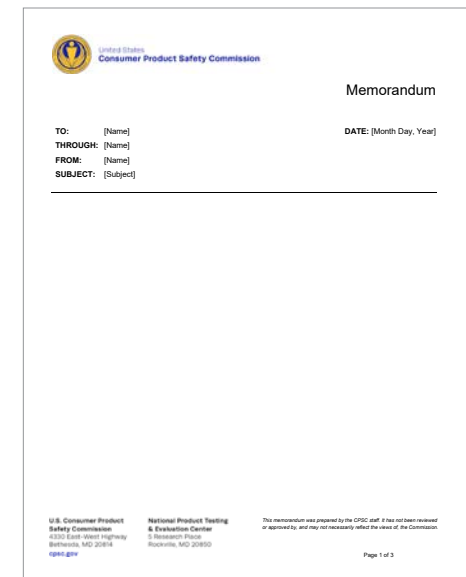
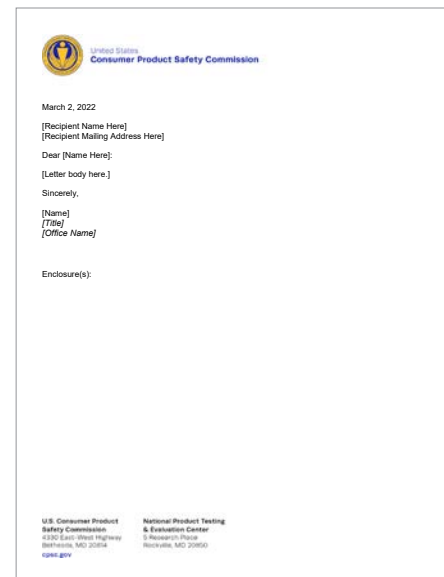
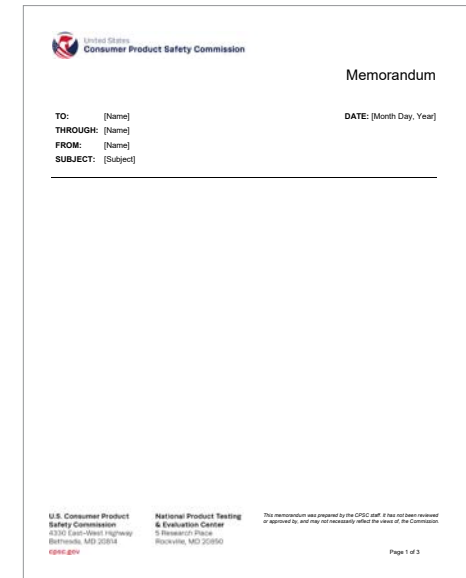
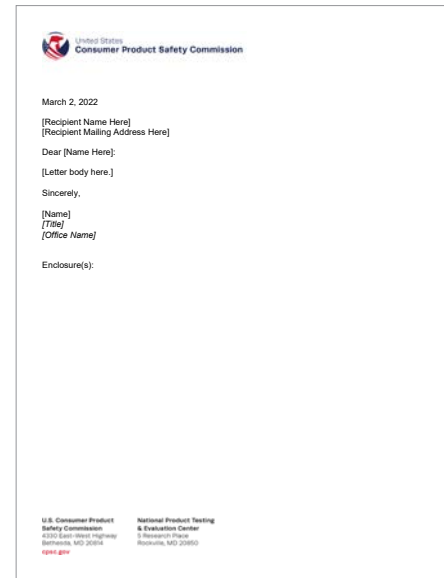

Application Examples

Overview

An email signature is our digital business card. A consistently branded email signature displayed throughout CPSC shows that we are a professional, cohesive organization with every email we send.

Email Signature Template

The email signature template includes text styles and colors that comply with CPSC's Branding Guidelines. Replace the template text with your contact information, delete what you don't need, then copy and paste it into Microsoft Outlook email signature options ([click here](#) for more information on how to set MS Outlook signature options).

The CPSC Chair and Commissioners are encouraged to follow our branding guidelines, suggested design shown to the right.

NOTE: The default disclaimer text that is added to external emails by EXIT will continue, and therefore CPSC's Branding Guidelines do not apply to it.

Template Text Styles

Settings used in the Email Signature Template text styles are listed to the right.

See Section 5.1 of this document for CPSC Red and CPSC Blue color formulas in RGB.

Email Signature

Dear Mr. Jones,

My contact information is in my signature below.

Regards,

Bob Smith

Specialist

U.S. Consumer Product Safety Commission | International Office

4330 East West Highway | Bethesda, MD 20814

Office: (301) 555-2100 | **Mobile:** (240) 555-2200 | **Fax:** (240) 555-2300

Follow Us: [Facebook](#), [Twitter](#), [Instagram](#), [YouTube](#)

Email Text Body Font: Arial, 11 pt., black

Name Font: Arial Bold, 12 pt., CPSC Blue

Title Font: Georgia, 11 pt., CPSC Red

Email Signature Body Font: Arial, 10 pt., CPSC Blue

Section Nine
PRODUCTION

Production

Overview

Our brand has been carefully developed in order to assure our quality of work is strong from start to finish. When it comes to producing the final product, we must ensure it meets the highest standard. This section is a guide to meeting those requirements. Use the information provided when preparing a file for print to guarantee best results.

CMYK: (cyan, magenta, yellow, black)
Use this color mode when designing materials for print.

Colors: Use PMS (Pantone) for primary brand colors when applicable.

Pantone: This customized method of printing is the best way to reproduce a color using premixed ink during the offset printing process.

Bleed: Add .125" bleed to any print document that includes graphics or colors that run off the page.

Section 9.1

Print and Digital Production

Print Material

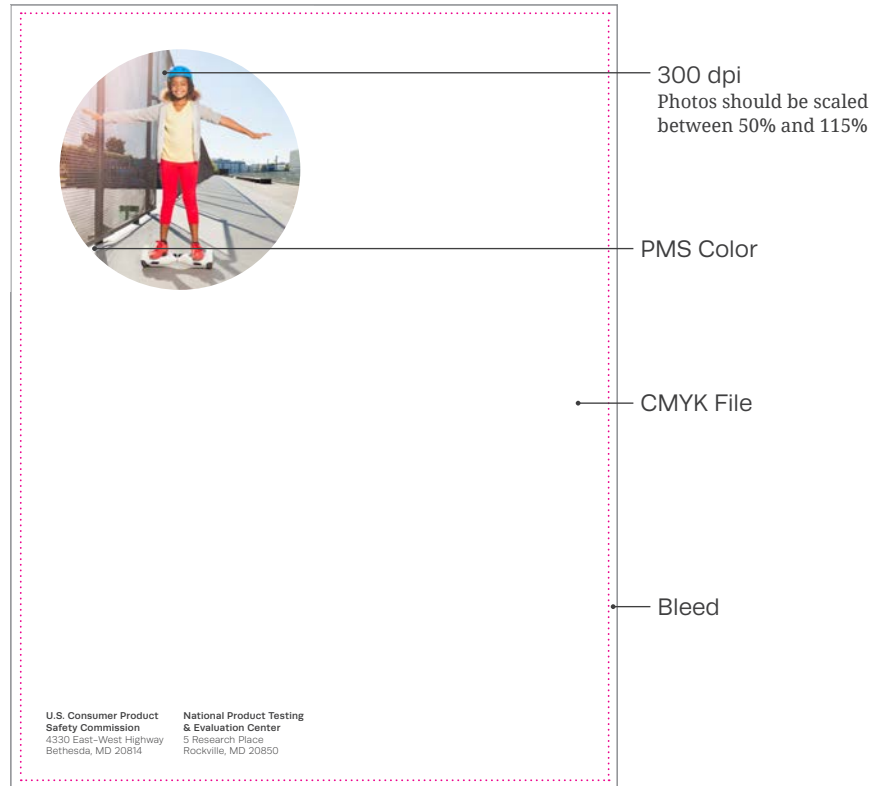

Production

Overview

Our brand has been carefully developed in order to assure our quality of work is strong from start to finish. When it comes to producing large-scale designs, we must ensure it meets the highest standard. This section is a guide to meeting those requirements. Use the information provided when preparing a file for print to guarantee best results.

CMYK: (cyan, magenta, yellow, black)
Use this color mode when designing materials for print.

Colors: Use PMS (Pantone) for primary brand colors when applicable.

Pantone: This customized method of printing is the best way to reproduce a color using premixed ink during the offset printing process.

Bleed: Add .125" bleed to any print document that includes graphics or colors that run off the page.

Trade Show / Large Format



Production

Overview

When it comes to producing digital work, we must ensure it meets the highest standard. This section is a guide to meeting those requirements. Use the information provided when preparing a file to guarantee best results.

RGB: (red, green, blue)

Use this color mode when designing for websites, television, social media, or cell phone apps.

Photography: Set photography to at least 72 dpi, and never use a pixelated image.

Video

When designing video it is important to include the CPSC logo in the bottom right corner of the frame. Select the version of the logo which has the best contrast against the video background so that the text in the ring is legible. Use consistent sizing and placement as follows:

Logo Placement:

Logo Size: 216x218

Logo Position:

Standard (1920x1080 Screen Size):

x:1616 y: 807

Vertical for Social (1080x1920 Screen Size):

x:754 y: 1604

Web Banner Image



72 dpi

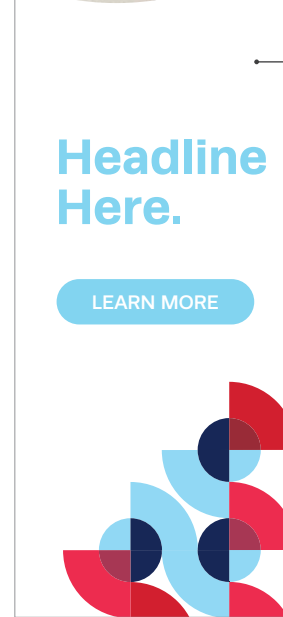

RGB File

Video



Overview

Paper can play an important role in how people interact with a product. To show our attention to detail, use these suggested paper stock weights and coatings for the listed applications.

Section 9.2

Paper Stock & Coatings

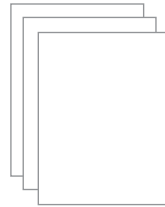

Printed White Paper Reports: 80lb Uncoated Text Weight for Cover and Interior.

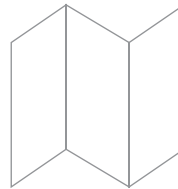

Brochures & Trifolds: 100lb Gloss Coated Cover & 100lb Text Weight Gloss Interior Pages.



Single Pagers & Posters: 100lb Gloss Coated.



Fans & Door Hangers: 100lb Cover Gloss Coated and 5 Mil Laminate Encapsulation.

Production

Overview

There are a few things to consider when deciding how to put a document together. The binding method can add to the overall aesthetic of the piece. On this page, we suggest which methods work best for different types of documents.

Saddle stitching is when folded pages are stapled at the center. It is usually best to saddle stitch when a brochure, catalog, or booklet is under 48 pages.

Perfect binding is used for catalogs, directories, and paperback books with higher page counts. The cover is wrapped around the pages, then trimmed to its finished size.

Score and fold is best for single-page brochures, cards, and pamphlets.

Section 9.3 Binding

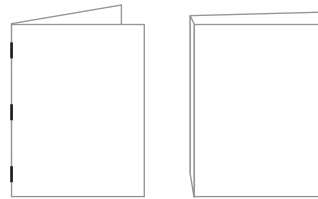

Saddle Stitched or Perfect Bind:
No Comb, Coil, or Wire-O Binding.

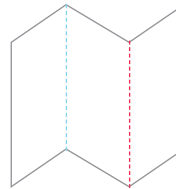

Score & Folds: Ridges that are indented into the paper where the fold line will occur.

Section Ten

508 COMPLIANCE



Section 10.1

508 Compliance

Section 508 requires that all website content be accessible to people with disabilities. This applies to web applications, web pages and all attached files on the Intranet, as well as, the Internet. CPSC staff are required to comply with the provisions of Section 508 and ensure accessibility of online electronic content, including but not limited to websites, web applications, multimedia, and office documents, including Word, PowerPoint, Excel, and PDF. GSA has put together guides and tutorials to provide methods to help you make your content accessible and Section 508 compliant. These resources can be accessed at the following url:

<https://www.section508.gov/>

Section Eleven
**RESOURCES
& CONTACTS**

Resources and Contacts

Assets and Templates

For CPSC branded templates visit:

<https://cpscgovdc.sharepoint.com/sites/CMSPPO/SitePages/CPSC-Branded-Templates.aspx>

Or use the link on the CPSCnet homepage– look for “Templates” under the “Quick Links” list on the right sidebar.

Contacts

For questions about CPSC’s branding:

Ann Bowen
Visual Information Specialist
Office of Communications
abowen@cpsc.gov

For general questions:

(800) 638-2772
info@cpsc.gov
cpsc.gov

U.S. Consumer Product Safety Commission

4330 East-West Highway
Bethesda, MD 20814

National Product Testing & Evaluation Center

5 Research Place
Rockville, MD 20850

