



# governmentattic.org

*"Rummaging in the government's attic"*

Description of document:	Beacon Hill Report: Problems of Air Force Intelligence and Reconnaissance, Project Lincoln, Massachusetts Institute of Technology (MIT), 1952
Request date:	28-July-2013
Released date:	27-May-2014
Posted date:	23-June-2014
Source of document:	SAF/AII (MDR) 1000 Air Force Pentagon Washington DC 20330-1000

The governmentattic.org web site ("the site") is noncommercial and free to the public. The site and materials made available on the site, such as this file, are for reference only. The governmentattic.org web site and its principals have made every effort to make this information as complete and as accurate as possible, however, there may be mistakes and omissions, both typographical and in content. The governmentattic.org web site and its principals shall have neither liability nor responsibility to any person or entity with respect to any loss or damage caused, or alleged to have been caused, directly or indirectly, by the information provided on the governmentattic.org web site or in this file. The public records published on the site were obtained from government agencies using proper legal channels. Each document is identified as to the source. Any concerns about the contents of the site should be directed to the agency originating the document in question. GovernmentAttic.org is not responsible for the contents of documents published on the website.



**DEPARTMENT OF THE AIR FORCE**  
WASHINGTON DC 20330-1000

**OFFICE OF THE SECRETARY**

May 27, 2014

SAF/AA (MDR)  
1000 Air Force Pentagon  
Washington, DC 20330-1000

Reference your letter dated 28 July 2013 to the Air Force for a Mandatory Declassification Review (MDR), for a copy of Beacon Hill Report: Problems of Air Force Intelligence and Reconnaissance.

The following document has been provided in response to our request.

Address questions concerning this case to the undersigned at 703-693-2560 and refer to case number 13-MDR-079

A handwritten signature in black ink, appearing to read "PJ", written over a light blue horizontal line.

PENNY JENKINS  
Mandatory Declassification Review Manager

1 Attachment  
Sanitized Copy

# IRIS Public Record

## Key Information

Main: MASSACHUSETTS INSTITUTE OF TECHNOLOGY

Document Type:  
Call Number: **K146.02-9**  
IRIS Number: **01067249**

Revd:	Rel	2011/01/0
Indexer ID: 25	Entered Date:	
QC ID: 28	QC'd Date::	2011/01/0
Scanner ID:	Scanned Date:	
Acc ID	Acc Date:	

Accessions Notes:  
Old Accession Nbr:

Title:  
Beginning Date:  
End Date:  
Publication Date: **1952/06/15**

Classification **CONFID**

Media Roll #: **0000039548** First Frame: **987** Last Frame: **0** Linear Feet: **0**  
Old MFlm Roll # Audio Rec:

NUMPAGE **0**

Title Extensions:

### Abstract

Descriptive Notes: FULL TEXT DOCUMENT IS AVAILABLE IN ELECTRONIC FORM VIA CLASSIFIED NETWORK.

Title Added Entries: **BEACON HILL REPORT, PROBLEMS OF AIR FORCE INTELLIGENCE AND RECONNAISSANCE, PROJECT LINCOLN**

Author:

Subject:

Major Command:

Doc Link: <http://207.84.84.190/GS/K146.2-9/19520615/01067249.pdf>

## Administrative Markings

Originating Authority Determination Requested -- OR -- Other administrative markings

Security Review Information:

K146.02-9  
15 Jun 52

RETURN TO  
Air Force  
Historical Research Center  
Maxwell AFB, AL 36112

BEACON HILL REPORT  
Problems of Air Force Intelligence  
and  
Reconnaissance  
15 June 1952

EXEMPTED FROM  
DECLASSIFICATION LAW EO 12958  
REVIEWER 60 REVIEW DATE 2/20/98  
REFER TO DIA  
EXEMPTION(S) ① 2 3 4 5 6 7 8 9

CLASSIFIED BY \_\_\_\_\_  
DECLASSIFY ON: DDO Dir 5700.01

PROJECT LINCOLN  
MASSACHUSETTS INSTITUTE OF TECHNOLOGY  
~~CONFIDENTIAL~~  
MICROFILMED BY TIM

SANITIZED COPY 21 MAY 2014

SECURITY INFORMATION

CONFIDENTIAL

# BEACON HILL REPORT

## PROBLEMS OF AIR FORCE INTELLIGENCE AND RECONNAISSANCE

15 JUNE 1952



PROJECT LINCOLN  
MASSACHUSETTS INSTITUTE OF TECHNOLOGY

SECURITY INFORMATION

RETURN TO  
Air Force  
Historical Research Center  
Maxwell AFB, AL 36112

K146.02-9  
15 JUN 52

01067349

86155

ALL - ~~A~~ 36774-2-C  
C. No. 198

198

~~CONFIDENTIAL~~

RETURN TO HQ USAF/DC MAXWELL AFB AL 36112-6078	
--	--

ERRATA

BEACON HILL REPORT

We regret that one page of Chapter 3 was omitted and several pages of Chapters 3 and 5 were inadvertently transposed in context in the assembly of this report. The correct sequence of reading is as follows:

Chapter 3

Read page 26, 28, 29, 27, new page 27a (attached), 30, 31, 32, 33.

Chapter 5

Read page 68, 70, 69, 72, 71.

We apologize for any confusion this may cause the reader.

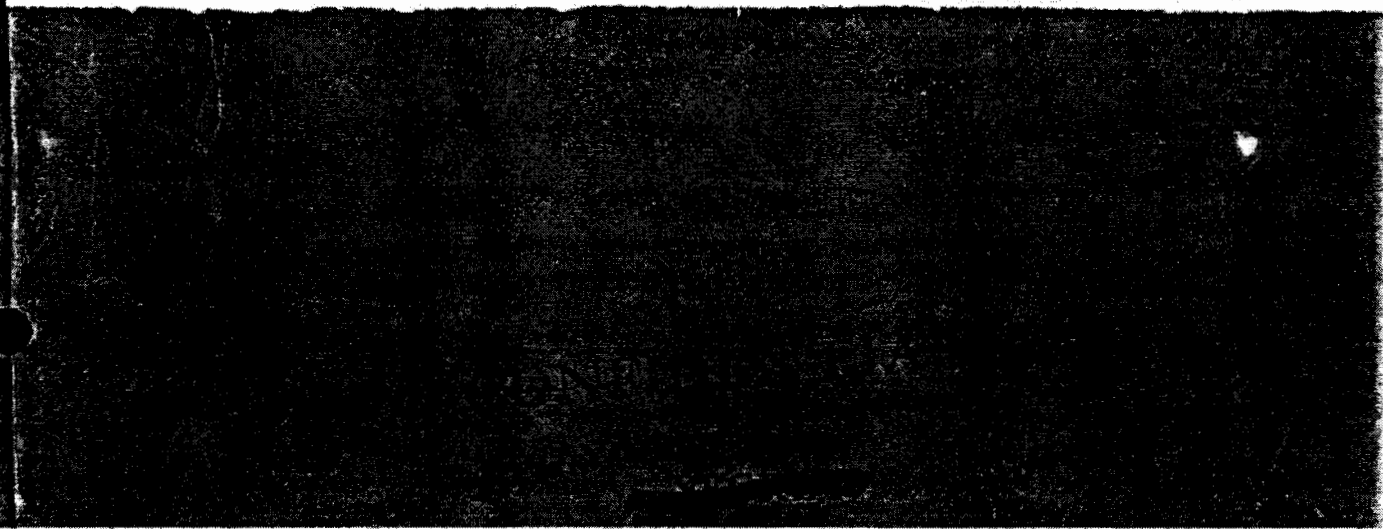

86155



~~CONFIDENTIAL~~

This document consists of  
292 pages. Copy 198  
of 700 copies.

PROJECT LINCOLN

BEACON HILL REPORT

PROBLEMS OF  
AIR FORCE INTELLIGENCE  
AND  
RECONNAISSANCE

15 June 1952

This document contains information affecting the national defense of the United States within the meaning of the Espionage Act, Title 18 U.S.C., Sections 793 and 794. The transmission or the revelation of its contents in any manner to an unauthorized person is prohibited by law.

MASSACHUSETTS INSTITUTE OF TECHNOLOGY

CAMBRIDGE

MASSACHUSETTS

~~CONFIDENTIAL~~



~~DOWNGRADED AT 12 YEAR  
INTERVALS, NOT AUTOMATICALLY  
DECLASSIFIED. DOD DIR 5200.10~~

[REDACTED]

~~CONFIDENTIAL~~

The Chief of Staff,  
United States Air Force

Dear Sir:

The Report transmitted with this letter deals with Air Force intelligence and reconnaissance. A research and development program of considerable magnitude already exists in this field. The purpose of the BEACON HILL Report is to point out opportunities for improving this program by changes in emphasis and extensions to new areas.

The study of Air Force intelligence and reconnaissance problems was first proposed to the Massachusetts Institute of Technology in May 1951 by the Deputy Chief of Staff, Development. In July 1951, the subject of strategic reconnaissance and intelligence was included in the scope of PROJECT LINCOLN.

As its initial activity in this field, PROJECT LINCOLN has assembled, under the chairmanship of Dr. Carl F. J. Overhage, a group of civilian consultants from various fields to make a survey of the current Air Force program in intelligence and reconnaissance and to suggest directions for future technical effort. This committee has been active from January to April 1952 as the BEACON HILL Study Group.

It was clear from the outset that in the short time available this group would reach useful conclusions only by concentrating its attention on a limited number of specific problems. The Report does not attempt to answer all the important questions directed at the Committee by the Air Force in the course of its briefings. A few major areas were excluded by prior agreement with the Air Staff: (1) all techniques related to the covert activities of secret agents, (2) those aspects of radio intercept requiring special clearances, and (3) the detection of atomic explosions. As the group became more familiar with its subject, additional problems had to be set aside. It has given less attention to tactical than to strategic air operations mainly because the former have been closely studied by PROJECT VISTA.

The subjects treated in the BEACON HILL Report fall into two rather different groups. In one part of its study, the group has tried to stand back and view in broad perspective the problem of orientation, emphasis, and priority as it applies to the over-all job of Air Force intelligence. In the other part, the group has wrestled with the technical problems involved in the collection, reduction and utilization of intelligence data. These are the fields most amenable to technological advance, and they are the fields in which most members of the group have specialized experience.

A 15-page summary of the BEACON HILL Report is presented as Chapter I. In order to make this a brief and readable account, the Study Group's views have been stated in this summary without some of the necessary qualifications to be found in the more detailed chapters that follow.

The committee recognizes that its findings represent only a beginning. The purpose of conducting a study of this type is to obtain the collective judgment of a selected group of scientists and engineers not normally associated with Air Force problems. In such a study, the advantages of a new and uninhibited approach to a very broad range of problems can be secured only by sacrificing the careful documentation and detailed support that ideally should accom-

v

~~CONFIDENTIAL~~

[REDACTED]



~~CONFIDENTIAL~~ [REDACTED]

pany each conclusion. Therefore, the work of this group must be followed by future and more detailed studies, by laboratory work, and by field tests. Above all, it must be combined with the operational experience of many officers and airmen before a real contribution will have been achieved.

We are indebted to our Air Force liaison officers for arranging frequent interchanges of information between BEACON HILL and the interested Air Force agencies. It has been impossible to give adequate credit for suggestions made in the course of such meetings. Many of the ideas advanced in our Report represent views held by individuals or groups now active in the Air Force intelligence and reconnaissance program. Exploratory experimental work in some of the new directions here discussed is already in progress within the research and development establishment of the Air Force as well as in outside laboratories.

Sincerely,

*F. W. Loomis.*

F. W. Loomis, Director  
PROJECT LINCOLN

Cambridge, Massachusetts  
2 June 1952

~~CONFIDENTIAL~~

~~CONFIDENTIAL~~

PROBLEMS OF AIR FORCE INTELLIGENCE  
AND  
RECONNAISSANCE

TABLE OF CONTENTS  
MAIN REPORT

	page
Letter of Transmittal	v
Preface	xi
Chapter 1 Summary	1
Chapter 2 Reorientation of the Air Force Intelligence Effort	19
Chapter 3 A Method for Establishing the Relative Importance of Information	25
Chapter 4 Surveillance of Radio and Radar Emissions	43
Chapter 5 Photographic Reconnaissance with Standard Equipment	63
Chapter 6 Photographic Reconnaissance with Specialized Equipment	77
Chapter 7 A New Approach to Photographic Reconnaissance	107
Chapter 8 Photoelectric Aids to Reconnaissance	113
Chapter 9 Radar	125
Chapter 10 Passive Infrared and Microwave Reconnaissance	151
Chapter 11 Reconnaissance Vehicles	163
Chapter 12 Specialized Reconnaissance Units	175
Chapter 13 Handling and Evaluation of Intelligence	183
Chapter 14 Careers in Intelligence	199

~~CONFIDENTIAL~~

~~SECRET~~

~~CONFIDENTIAL~~

TABLE OF CONTENTS

APPENDICES

to

MAIN REPORT

		page
Appendix A	Organization of the BEACON HILL Study Group	a-3
Appendix B	BEACON HILL Briefing Schedule	a-9
Appendix C	Problems of the Photographic Method	a-17
Appendix D	The Effect of Atomic Weapons on Photo-Reconnaissance Operations	a-43
Appendix E	Means for Avoiding Fluctuations of Brightness of the Radar Echo	a-49
Appendix F	Cathode-Ray Tube Resolution	a-53
Appendix G	Radar Predictions	a-57
Appendix H	Radar Reconnaissance in Northern Latitudes	a-63
Appendix I	Acoustic Sensing Techniques for Intelligence Use	a-67

~~CONFIDENTIAL~~

~~SECRET~~

~~SECRET~~

~~CONFIDENTIAL~~

PREFACE

The BEACON HILL Study Group, like similar committees drawn together for an intensive short-term survey of a particular military problem, comprised a cross section of academic and industrial specialists in fields that ranged from psychology to physics and optics.

Fifteen members constituted the Central Study Group and ten consultants provided needed counsel as particular problems were encountered. Five Air Force liaison officers were assigned to the Group, facilitating access to documents, making possible the contacts with representatives of Air Force laboratories and agencies, and serving generally as sources of information. The complete roster of the BEACON HILL organization is given in Appendix A.

The Group received its information on the current Air Force program at Briefings conducted in Washington, and at various Air Force establishments, between 7 January and 15 February 1952. Thereafter the committee adopted a working pattern that had proven itself satisfactory in previous projects at M. I. T. Established in quarters separate from the LINCOLN installations, with adequate security safeguards and a small administrative staff, the group began its activities by reviewing and examining its impressions of the formal Air Force presentations. The areas to which the group could profitably hope to contribute were then defined, and panels on the three major segments - intelligence objectives, sensing means, and data handling - were organized. Subsequently, a group on vehicle systems was formed.

The working schedule evolved around a three-day week to allow members both to serve the Study Group and to maintain academic and professional commitments. During February and March, the panels met in working sessions, visited pertinent military and private establishments, and received additional briefings from visitors and consultants (see Appendix A). Throughout this period of concentrated study, individuals and subcommittees issued working papers covering their questions, findings, and tentative recommendations. These were discussed in weekly joint sessions of the entire body, including the liaison officers.

By the middle of April, the major conclusions had been formulated, and substantial agreement reached, on the primary findings. An oral presentation of these was given first to a jury of consultants and invited Air Force personnel and subsequently (on 26 May 1952) to the Air Staff. An editorial committee then combined the final drafts of the relevant working papers into a unified report which was submitted to each member of the Study Group for correction and comment. Since only minor changes of wording and emphasis resulted from this final review, the Report as presented in the following pages represents the joint agreement and bears the endorsement of the entire study group.

In any project such as this, the line of demarcation between committee structures is a difficult one to trace. Similarly, the assigning of responsibilities and identification of authorship cannot be made easily. The cross-fertilization of ideas, the evolution of new and different approaches among a group such as this - all make for a document that bears the imprint of each member on every chapter and section. In addition to this acknowledgment of the contributions of all individuals to the entire Report, it is necessary to give particular credit to certain persons who assumed primary responsibility for assembling and integrating the various working papers into coherent chapters:

~~CONFIDENTIAL~~

~~CONFIDENTIAL~~

- Chapter 1 - Saville Davis
- Chapter 2 - S. S. Stevens and Gordon P. Saville
- Chapter 3 - Gordon P. Saville and S. S. Stevens
- Chapter 4 - E. M. Purcell and S. E. Miller
- Chapter 5 - J. G. Baker
- Chapter 6 - J. G. Baker
- Chapter 7 - E. H. Land
- Chapter 8 - P. C. Goldmark and G. K. Geerlings
- Chapter 9 - E. M. Purcell and S. E. Miller
- Chapter 10 - S. E. Miller and E. M. Purcell
- Chapter 11 - A. F. Donovan and L. N. Ridenour
- Chapter 12 - J. G. Baker
- Chapter 13 - G. W. King
- Chapter 14 - G. K. Geerlings and G. W. King

A series of lettered Appendices has been included at the end of the Report. These, in many cases, are working papers that serve to amplify the material in the Chapters, or to present individual ideas that the group felt worthy of submission to the Air Force. Accordingly, each Appendix carries the name of the author.

No project of this scope could have functioned efficiently without the support and cooperation of its liaison officers. BEACON HILL has been more than fortunate in the caliber of the men assigned to it. To all of them, the Study Group is indebted for their willingness and patience, and for the genuine contributions they made to this Report.

~~CONFIDENTIAL~~

~~CONFIDENTIAL~~

## SUMMARY

### CHAPTER 1

#### THE IMPORTANCE OF INTELLIGENCE

IN the post-war world, intelligence and reconnaissance are more important to the United States by several orders of magnitude than ever before. They are crucial to some of the most fundamental aims in our national policy: our ability to keep the American economy solvent and sustain the cold war; the ability of our armed force to discourage aggression and thereby to keep the peace; our capacity, if war comes, to outmatch the enemy and carry the war to the Soviet Union; our capacity, in the face of a Soviet intercontinental striking force with atomic weapons, to seek out and master that force - and thereby to safeguard our people and our economic and military resources from atomic destruction. All these tasks depend to a wholly unprecedented degree on intelligence.

THE American economy is now seriously strained by the inflated cost of armament. Given less than adequate intelligence, there is an unavoidable tendency to spend generously as an insurance factor - to prepare, without adequate knowledge of what the Soviet Union has, to counter everything we think it conceivably might have. With more exact knowledge, we can decide which military spending is directed accurately at the mark and which is unnecessary spending-in-the-dark. Informed spending is the best means of economy.

OUR containment policy faces a Soviet strategy of local incidents and surprise aggressions. We are forced to meet this with an increasingly mobile "fire department" technique, with limited forces holding the line at widely separated danger zones across the world. Advance knowledge is of the essence in this conflict of maneuver.

THIS country is now an integral part of the balance of power. We consciously use armed strength now as an instrument of national policy - first, as a peaceable deterrent to war-making and second, to prepare for war if it comes. There is no more isolation. For the first time in our history, we have come to accept the need for a major military force-in-being, during what passes nowadays for time of peace.

BUT a large military force is not enough. Indeed by itself, it is utterly inadequate. For the Soviet Union has a large force-in-being also. And with two such forces matched against each other, the question now becomes: which is smarter? Which can learn more about the vulnerability of the other, and adapt its force most shrewdly and precisely to exploit the other's weakness? This is the question that intelligence must answer. We are smarter only if we know more - about the enemy's strength, his weakness, his plans. This knowledge will enable us to match him or meet him on our own terms. But this knowledge, derived from intelligence, has an even greater significance. By showing us where to concentrate

## SUMMARY

~~CONFIDENTIAL~~

## SUMMARY

our strength, where to plug gaps, where to ignore his preparations, intelligence allows us to husband our economic resources and to keep fit for the long-term struggle.

### APPROACH TO THE PROBLEM

LIKE any other problem, the study of intelligence begins with a review of fundamentals. What are basic national objectives? Basic intelligence data? Basic sensing means?

Basic uses? How can a thorough examination of these matters give a sense of direction to those responsible for program control and for operating the entire intelligence system?

WE have gone through this kind of analysis ourselves, in order to put our detailed study of various technical fields into broader perspective. We believe we have ploughed some new ground in doing so. We have come up with certain broad conclusions which cut across whole segments of the intelligence picture and which will be reviewed in the next few sections of this chapter.

### COUNTER-FORCE INTELLIGENCE

WE are struck by the overriding importance, and the relatively small supply, of current intelligence on two subjects: basic Soviet weapons and basic Soviet combat forces. We

realize that intensive effort has been made to get at this kind of intelligence, and that some of this effort may well lie beyond the range of inquiry of this study group. But we understand that, in terms of a really comprehensive, steady flow of information, the task has been peculiarly frustrating. We find that a very large part of the Air Force intelligence effort is headed in the somewhat easier direction of improving our stock of industrial and economic intelligence.

YET we regard data on Soviet weapons and forces as of far greater importance.

THERE will scarcely be argument over the reasons why. The missions of TAC are counter-force in nature. Two of SAC's three missions fall in the same category. The period when force data were less important - when we alone possessed the atomic bomb - has passed. Now that the Soviet Union has the same kind of striking power, the military problem becomes more nearly one of basic weapons against basic weapons, of striking force against striking force.

WE became convinced, therefore, that an even greater effort should be made to know the Soviet military force - what and where it is, how it operates, what its movements are - and that this calls for a redistribution of emphasis in the Air Force intelligence effort.

SUMMARY

~~CONFIDENTIAL~~

~~SECRET~~

## SUMMARY

### NEED FOR INFORMATION PRIORITIES

GENERALLY speaking, intelligence is now collected on a broadly inclusive basis. In the familiar but devastating phrase, everyone wants to know everything about everything, all the time. The result is a collection of an indigestible mass of raw information which even the best system could not wholly convert into useful finished intelligence.

WE can understand the reason for this: the collector cannot know which innocent looking item might be the vital link in a pattern someone is trying to fit together. So he collects as much as he can, to fill the very long list of requests given him. The evaluators will sort it out. But, in practice, this creates a fresh problem. Collectors and evaluators are swamped. Instead of being free to do a sharply analytical job, going after what is most needed and making sense out of what they get, the physical pressure of handling so much material tends to absorb their energy.

WE have come to the conclusion, therefore, that we must go back to the concept of the "essential elements of information." With basic intelligence needs more clearly defined at the top, information priorities can be set up for the whole system. Intelligence can then be collected and evaluated more in terms of what it will be used for.

### A METHOD FOR ASSIGNING PRIORITIES

IT calls for some tall thinking to set up intelligence priorities. By itself, the mature judgment of experienced officers can do much in this direction. But this same mature judgment aided by a systematic analysis of the whole intelligence field can do even more.

SO we propose a possible working procedure for establishing information priorities. It is a method for gathering into significant categories all the subjects about which information is sought and all the end uses served by the information. It also provides a procedure for rating the categories numerically in terms of their relative importance.

CHAPTER 3 gives a tentative example of such a method. We do not claim it is infallible, or even that it is the best way to do the job. But we believe it is good enough to show that some such method can further the task of putting first things first in intelligence.

FRANKLY, the discipline of a method like this may well be its chief virtue. Just the effort to think it through may prove more useful than the particular numerical outcome. It can assist in looking into corners that might otherwise be forgotten and can thereby excite a new depth of thinking. We have found it so in our own review of the basic intelligence problem. In any event, we suggest that this method be tried out as an initial step.

## SUMMARY



~~CONFIDENTIAL~~  
SUMMARY

then modified and improved as experience dictates.

ELECTROMAGNETIC  
INTERCEPT

WE are convinced that the peacetime collection of information on Soviet military forces can be significantly increased. One promising means could shortly be in hand. It is electromagnetic intercept, specifically adapted to this purpose. A modern military force with its variety of communications and electronic equipment must assign frequencies to basic weapons and combat units on an orderly basis. It thus gives off a multitude of tell-tale emissions. Detection of these - not primarily of their message content, but of their existence and approximate location - offers a promising means of identification. It should be possible to locate aircraft as well as missiles and control centers and, by watching the pattern of emissions, keep a rough track of combat units, their sizes and movements. In Chapter 4, we shall discuss equipment and procedures for collecting this information. We shall consider both radio and radar intercept, because we regard these as two inseparable aspects of the same important intelligence job. But we have been briefed only on radar intercept; our suggestions on radio intercept are therefore advanced without knowledge of what may already be in operation.

TO get information on Soviet forces we need radio and radar intercept receivers that can operate unattended, cover a wide bandwidth, and automatically detect and record approximate signal frequency, signal direction and flight data.

FOR radio intercept, we shall describe one possible approach in which the advantages of superheterodyne receivers are sacrificed in order to gain high intercept probability.

PRESENT radar intercept equipment was built primarily for electronic countermeasures, where the chief requirement is detailed analysis of Soviet electronic signals. Such equipment is bulky and complex and requires manual operation. Since its intercept probability is very small, it should be confined to its present important and specialized purpose. For the broader problem of comprehensive surveillance, where high probability of intercept is the chief requirement, crystal video techniques could be promptly utilized.

FULL use of radio and radar intercept would involve operations from ground stations as well as from the air. The line-of-sight limitation of border ground stations could be overcome with repeaters carried by aircraft or balloons in friendly airspace. Occurrences of anomalous propagation are also worth full exploitation.

SUMMARY

~~CONFIDENTIAL~~

~~SECRET~~

## SUMMARY

### PHOTOGRAPHIC RECONNAISSANCE

BETWEEN the field users of photo-reconnaissance equipment and the designers of it, a serious conflict has grown up. Operating personnel want simple, small-sized, light-weight general-purpose cameras, easy to handle by a single person under combat conditions, easy to mass-produce and to supply and repair. The designer, on the other hand, wants to provide the Air Force with the ultimate photographic performance that American technology can produce. The resulting instruments are so large and complex that they become ineffective in the hands of average personnel.

WE believe this conflict can be resolved. The solution is to separate the two functions of standardization and specialization and give each the equipment and working conditions that are best for its own peculiar needs. Standardized equipment ought to be used, at a rough guess, for 95 per cent of Air Force photo-reconnaissance, and this should not be handicapped by having specialized cameras mixed into standard use.

FOR the remaining 5 per cent, we shall recommend employment of specialized equipment by specialized photo-reconnaissance units set up for the purpose. These units would include highly trained personnel who alone can fully exploit the potentialities of the modern photographic art. The concept of specialized units is introduced at this point because the need for them is peculiarly well illustrated in the field of aerial photography. However, we shall also recommend later on that specialized units be used for other forms of reconnaissance, such as radio and radar intercept. We leave to those who are competent to decide the question of how these units should fit into the Air Force structure.

FOR normal photo-reconnaissance tasks using standardized equipment, we shall make a number of recommendations. They include, among others, the following.

- (1) Image-motion compensation and antivibration mounts are now musts, and, as the VISTA report has already urged, should be pushed with the greatest vigor. Lack of them now is an intolerable limitation on quality.
- (2) A small, fast-cycling, wide-angle 70-mm camera with shutter speeds up to 1/2000-second and with image-motion compensation is needed for use in fighter planes flying at very low altitudes.
- (3) No lenses of focal length greater than 36 inches should be mass-produced for standard use. Anything larger should be turned over to the specialized reconnaissance units.

SPECIALIZED equipment must be designed to be less bulky and complex than what we now

## SUMMARY

~~CONFIDENTIAL~~

## SUMMARY

have, particularly since many special photo-reconnaissance tasks in the future will be carried out by guided missiles and rocket aircraft.

ONE of the most challenging tasks for these specialized missions will be extreme-altitude oblique photography carried on from special aircraft at safe distances on our side of the Soviet perimeter. The step immediately ahead is to use a high-altitude turbojet plane at 70,000 feet, as soon as it is available. With proper camera equipment, it should be possible to see 100 miles into Soviet territory from a point 25 miles outside the frontier.

THE X-2, we are informed, can be expected to reach an altitude of 45 miles before very long. If it carried a compact camera of long focal length such as we believe possible, and of much lighter weight than present equipment, it could in excellent weather photograph details as small as 100 feet on a side some 300 miles inside the U.S.S.R.

THE WAC CORPORAL has been up to 250 miles. With a heavier rocket at an altitude of, say, 200 miles, we may ultimately hope to photograph up to 1000 miles into the U.S.S.R. with usable detail.

THIS amounts to applying the astronomer's techniques to observing the surface of the earth. We recommend intensive further study of the feasibility of this approach. If it should prove workable, we could send up rockets from safe points around the Soviet perimeter, and under favorable weather conditions search a large part of the U.S.S.R. Success in this venture would provide a substantial amount of information now considered obtainable only by penetration of Soviet airspace.

RETURNING from these highly specialized tasks to the problems of normal reconnaissance operations, we shall discuss in Chapter 7 a new approach intended to carry standardization to its greatest practical limit. This approach, which we have called the "Reconograph System," is based on a small general-purpose camera that could really exploit the opportunities that smallness can provide. All the engineering would be built into one integrated package that includes camera, mounting and automatic controls.

THE camera would be small enough to be mounted at the center of a stabilizing system in such a way as to provide smooth, accurate image-motion compensation. This would make possible a relatively long exposure, and with the right emulsion it should produce stereoscopic pictures of much higher quality than is now thought possible for the small camera. The film would pass from the camera unit into a compact and automatic processing device from which it would emerge as a negative or positive transparency. This would be direct-

**SUMMARY**

~~CONFIDENTIAL~~

~~SECRET~~

## SUMMARY

ly viewed by the interpreter in a variable-magnification binocular microscope.

WE shall recommend the development of such a camera. We believe it will lead to a major simplification of photo-reconnaissance.

### PHOTOELECTRIC AIDS TO RECONNAISSANCE

TELEVISION and facsimile are substantially ready to be applied to reconnaissance. Techniques are in hand, components are on the shelf or can be easily developed. We shall

recommend systems:

- (1) To "view" the terrain under a reconnaissance aircraft or missile by what is essentially a television technique, and to relay the picture information back to another aircraft or to a ground receiver.
- (2) Similarly, to relay reconnaissance photos taken by rapid-process cameras.
- (3) Similarly, to relay radar-scope photos.

THESE systems would use line-of-sight transmission with a relatively narrow video bandwidth (no greater than 250 kc). Transmission over longer distances and code modulation to minimize jamming should be explored.

### NIGHT AND BAD WEATHER CAPABILITY

NIGHT and bad-weather capability is unquestionably one of the greatest reconnaissance needs. Existing radar falls short of the goal: the picture it gives is adequate for navigation but too crude to yield useful intelligence. Flash photography, even on the clear nights when it is feasible, is severely limited in application because of the need to carry illuminants. Use of the infrared, while helping to overcome the illuminant problem, is still limited to clear weather conditions. Photography in the near-infrared is not much more promising. On the other hand, two methods of getting the capability we need show great potentialities. One is to improve radar resolution radically, by means now at hand. The other is to tap a new source of earth pictures, microwave thermal radiation.

### Radar

AIRBORNE radar, whether used for bombing or for aerial reconnaissance, is now seriously handicapped by poor angular resolution. No great improvement is to be expected from elaborate presentation schemes, although a modest improvement in the present basic equipment can be achieved through the use of cathode-ray tubes with sharper focus. A fundamental advance can be made by using narrower radar beams, achieved by increasing the antenna aperture, or shortening the wavelength, or both. Not only will this reduce the difficulty of target identification in bombing - it will make radar reconnaissance useful for other important purposes.

## SUMMARY

~~CONFIDENTIAL~~

## SUMMARY

THE most hopeful development in reconnaissance radar is the fixed side-looking array combined with strip recording. It makes high-resolution radar feasible, even for fighter-type reconnaissance aircraft. A specific proposal directed at such an application is made in Chapter 9. Another very promising technique, now in an early stage of development, is strip recording by pulse-Doppler analysis.

WE believe the time has come to treat 1.8 cm (the  $K_u$  band) as the basic wavelength for pictorial radar. The development of the  $K_a$  band (0.85 cm) should be promoted for use in the near future; it will have important applications where extreme range is not required.

EFFORTS to improve radar prediction should concentrate on the simplest of the procedures now used, which should be improved and validated by more extensive operational trials. More elaborate methods are not promising. Users and planners must be aware of the fundamental physical limitations of any prediction scheme.

THE development of presentation gadgetry, now proceeding along several lines, should not be allowed to divert attention from the need to improve the inherent resolution of radar itself.

**Passive Infrared** IF the reception of infrared and microwave thermal radiation lives up  
**Microwave Receivers** to its promise, it will give sturdy competition to the best radar. Initial experiments with infrared already show excellent details. The receiver can "see" through clear darkness of course; but through overcast it does only slightly better than optical instruments. Microwave radiations seem perhaps more promising, since they could see through cloud as well as night, and would, in contrast to microwave radar, involve no active emission from the aircraft. If successful, it will be possible over limited ranges to see through bad weather and darkness a picture that approximates a crude optical picture. This method is yet to be developed but we believe it is feasible and we shall recommend research and development with great urgency.

**PRE-D-DAY** THIS report takes for granted the maximum use of border  
**PENETRATION** surveillance. We especially emphasize high-oblique photography and radio and radar surveillance. The limited range of these techniques, however, poses a serious question. Should there be pre-D-Day invasion of enemy airspace?

WE discuss this question reluctantly. We as citizens realize that very grave questions of national policy are involved, and, speaking as citizens, we should want these questions treated with the utmost political wisdom. On the other hand, we presume that a decision

**SUMMARY**

~~CONFIDENTIAL~~

~~CONFIDENTIAL~~

## SUMMARY

on this question of high policy would not be made without knowing what the various vehicles could accomplish:

- How well could they evade detection?
- How well could they avoid interception?
- How useful is the information they could bring back?

NONE of the more promising vehicles has yet reached the point where these questions can be confidently answered. We shall propose, therefore, that certain of these vehicles be pushed rapidly to the point of feasibility trials.

CONTROLLED search of the Soviet Union, in our opinion, would serve a much better purpose than random, uncontrolled search. Vehicles capable of precision search can be produced, with effort, in the time period immediately ahead. They include the extreme-high-altitude plane and the unmanned guided missile such as SNARK. If a simple guidance system sufficient for reconnaissance were installed, this vehicle could be tested fairly soon.

HIGH-altitude balloons have more limitations than vehicles with power. They can be directed only in the general sense that wind currents over the Soviet Union can be anticipated. The resulting general search is inefficient compared with the coverage obtainable from guided vehicles. There are other technical difficulties which we have not analyzed in detail. But if balloons should prove politically more acceptable than aircraft and missiles as a means of pre-D-Day penetration, then every effort will be made to overcome their limitations.

SINCE this "if" is beyond our range of inquiry, we confine ourselves to suggesting further research on winds, equipment and recovering and development problems before final-phase engineering production is initiated.

### SURVIVAL OF RECONNAISSANCE AIRCRAFT

ONE priority outranks all others: to restore the ability of reconnaissance aircraft to live. Today's planes have a dangerously high attrition rate against a first-class air power.

This is the single greatest weakness in the reconnaissance system now. It calls for putting speed, and both high- and low-altitude capabilities, ahead of all else. Reconnaissance will need the highest-performance aircraft available at any particular time.

WE are convinced that the present vulnerability can be corrected in progressive stages, beginning at once, using planes and equipment now in hand. Among other things, we shall recommend using fighter planes for reconnaissance, adapting the F-84E or F-84G as an

## SUMMARY

~~CONFIDENTIAL~~

## SUMMARY

interim measure, giving high priority to the forthcoming RF-84. Wherever possible, excessive fuel weights and the resulting poor target performance should be avoided by the use of peripheral bases and air-refueling and parasiting facilities. This is the immediate problem - to improvise our way rapidly out of the present inadequacy.

THEN, looking further ahead, we see the need for a more fundamental approach: an integrated, balanced designing of the package as a whole - of vehicle and equipment. Aircraft performance is at a discount under a system of accretion, where a mass of equipment, independently conceived, in uncoordinated units, with excessive weight and bulk, is forced on a vehicle not designed to accommodate it.

THIS need for integrated reconnaissance vehicle design is well recognized in the Air Force, and the current program on the MX1626 illustrates the type of planning that is needed. Another important step in this direction is the increasing attention given to interchangeable noses or pods containing different sensing equipment for the different reconnaissance tasks (photographic, radar, passive, electromagnetic intercept, etc.). Certain types of especially light equipment can go on combat as well as on reconnaissance planes, in order to make the maximum use of combat flights for collecting information.

### RECOMMENDED VEHICLES

WHAT, now, of the vehicles? Both for border surveillance and as possible vehicles for penetration, pre-D-Day aircraft have been discussed already. (Most of them would, of course, be used fully in the post-D-Day period as well.) They comprise:

- (1) High-altitude manned turbojet aircraft (modified Canberra or RB-66).
- (2) Extreme-altitude, limited-range rocket aircraft of the X-2 type, for border surveillance or limited penetration.
- (3) Unmanned reconnaissance aircraft, like SNARK, with simple guidance systems.
- (4) High-altitude balloons.

Or later, after 1956:

- (5) Extreme-altitude rocket aircraft with range between that of the X-2 and the intercontinental missile.
- (6) Supersonic long-range guided missile (NAVAHO).

FOR strategic operations in the post-D-Day period, if it comes before 1956, we suggest emphasis on:

- (1) Modified F-84E or F-84G with maximum range extension, as an interim capability.

**SUMMARY**

~~CONFIDENTIAL~~

~~CONFIDENTIAL~~

## SUMMARY

(2) RF-84 or RF-101 for a radius up to 1000 miles, to be fitted with interchangeable noses and given refueling or parasite capabilities.

(3) RB-47 for greater equipment capacity and range up to 2500 miles.

For use after 1956, we would add to the list:

(4) A reconnaissance version of supersonic medium bomber - MX1626 or MX1712.

(5) A terminal missile like SHRIKE, with photoelectric scanner and radio relay, to be used with the supersonic medium bomber.

PROGRAMS should be undertaken to adapt vehicles such as the extreme-altitude fighter, the SNARK, the X-2 and the SHRIKE to their various reconnaissance tasks, to give them feasibility tests as soon as possible, to evaluate their capabilities for reconnaissance, and to determine how well they could evade detection and interception.

### SPECIALIZED RECONNAISSANCE UNITS

IN the discussion of photo-reconnaissance, we have already suggested a means of unsnarling the confusion between general-purpose and specialized equipment: to separate out the more complex cameras and difficult missions and turn them over to specialized units. The same separation of "standard" and "specialized" should be carried out for the other forms of reconnaissance: radar, electromagnetic intercept, etc. In these fields also, there is need for simple equipment that can be used in interchangeable noses and pods, with combat as well as reconnaissance planes. There is likewise as in photography, a place for intricate equipment operated by trained personnel, which should be assigned to a few specialized units that can go all out for the highest quality of reconnaissance.

### WORD-OF-MOUTH SOURCES

THE BEACON HILL Study Group has not concerned itself with intelligence obtained by the covert activities of secret agents. Our primary interest has been in technical methods of data collection. While we see great opportunities of improving these objective techniques, we are not unmindful of the great importance of word-of-mouth intelligence and we cannot help but reflect on the enormous expenditures of time and effort by ordinary data collection means that could be eclipsed by reaching one Klaus Fuchs in the Soviet Union.

MEANWHILE, there are large numbers of European industrial concerns and scientists with access to current information about satellite and Soviet research and production. They either make equipment or materials for the U.S.S.R. and satellite areas, or have professional and business friends who are doing so. They often have direct connections with industries and scientists behind the Iron Curtain.

## SUMMARY

~~CONFIDENTIAL~~

~~SECRET~~



# ~~CONFIDENTIAL~~ SUMMARY

THE systematic exploitation of these sources would require the services of qualified American businessmen, engineers and scientists in conjunction with research and development contracts awarded to European firms. We have not been able to make a detailed study of such a program or of other overt sources of word-of-mouth intelligence, and thus no specific recommendations are offered in our Report.

## STREAMLINED DATA HANDLING

THE entire process of handling intelligence data, from collection all the way through to dissemination and use, could greatly benefit from overhauling. Few efforts in the field of intelligence offer more generous promise of rich rewards.

CONGESTION in the present system is understandable, because the demands on it have expanded rapidly at the same time that intelligence has become technically more complex. Despite all efforts to control it, the system is now engulfed by a deluge of raw data. It clogs communications, causes many delays, is evaluated at too many different levels, is difficult to sort out conscientiously, is processed by hand in areas where the time is now ripe for mechanized sorting and handling, is requested by more people than need it, and is handicapped by the lack of enough carefully chosen, well-trained evaluators who can look forward to stable, rewarding careers in Air Force intelligence.

WE shall suggest that good information-handling techniques are available, or within reach, so that a smoother and more efficient system is a reasonable possibility, and fairly soon.

IN Chapter 13, we propose a general tightening and streamlining of data handling. It follows several general principles.

(1) By greater use of information priorities, collectors of raw data should be able to concentrate more on what's needed, and eliminate more of what's not needed. This would tend to reduce the volume of flow at the start of the process.

(2) Evaluation should take place as far forward in the intelligence process, and as near the collection point, as possible. Only selected, interpreted information should be transmitted back through channels by the evaluators. This would still further cut the volume of flow at an early stage of the process.

(3) There should be rigorous cuts in the flow of information to persons not functionally needing it. Considerable duplication in the channels through which intelligence flows can be eliminated.

## SUMMARY

~~CONFIDENTIAL~~

12

~~SECRET~~

**SUMMARY**

FOR the mechanized handling of fragmentary information, we shall recommend an integrated system with the following salient features.

- (1) All material arriving at Documents and Dissemination Branch would, on receipt, be photographed on microfilm.
- (2) A simple and effective system ("coordinate indexing") could identify the material on each frame by a few key words, which would be recorded on the film in such a way as to permit rapid mechanical sorting.
- (3) Machines would speedily locate all the frames of interest to any particular inquirer, and make for him prints that he would not need to return.

THIS mechanized system can be given a restricted test, to work out the flaws, without large expense or final commitment. If found successful, the entire system can be put into operation progressively.

**CAREERS  
IN INTELLIGENCE**

EVERY study group, we gather, comes up with this idea: the particular Air Force activity it is studying should have the most able and the best trained personnel in the Service.

The Air Force puts great effort into selecting and training the men who fly airplanes. We believe it should do likewise for the men who enable airplanes to fly to the right place, with foreknowledge of the conditions they will encounter.

THERE are good reasons why the Air Force has competent flyers:

- (1) It reserves certain jobs for specially trained personnel (pilot, bombardier, navigator, etc.);
- (2) It sets up ways of measuring individual aptitudes for these jobs, and selects its men thereby;
- (3) It gives them specialized training;
- (4) It checks periodically on their competence;
- (5) It eliminates the incompetent, and rewards the competent with attractive careers.

EVERYONE understands why this formidable list of safeguards is necessary for the men who operate planes. We are convinced that it is likewise necessary for intelligence officers; they require particular talents that may not fit into the normal Air Force pattern, and as a result they cannot be selected properly by rotation or casual choice.

INTELLIGENCE officers have to be keen analysts, with a faculty for locating what are the really significant facts in a mass of data. They need the kind of judgment that can exam-

**SUMMARY**

~~CONFIDENTIAL~~

~~SECRET~~

## SUMMARY

ine sources of information and tell how reliable or unreliable they are. They need the sort of creative imagination that can relate facts from different sources, and tell when they have established a pattern and when they have not. They need a compelling interest in the job, which will carry them through the endless drudgery of combing over vast quantities of material in search of nuggets, without their interest flagging. These are qualities not unlike those of a good police detective or newspaper reporter, and they may be quite different from the talents making a good pilot or engineer or supply officer.

THESE qualities are needed not only by the men who interview defectors or interpret photographs, but by administrative intelligence personnel in general. Otherwise, men who do not have this sharp, investigatory type of mind and whose talents lie elsewhere will be rotated in and out of intelligence and will fail to appreciate the sensitive nature of the work.

FOR air technical intelligence, it is necessary not only to have these investigating qualities but a technical background as well, with breadth and some depth in at least one field. Both types of talent can be found in the same individual, but not without careful search and selection.

WE are told that a study of better career incentives for intelligence is being made, and we strongly endorse that effort. In the past, we are informed, there has been a general feeling that "almost anyone can be an intelligence officer." A man who failed as a navigator after months of training, might find himself transferred to intelligence where he was expected to make good with no training.

WE recommend that the introduction of better career incentives for intelligence personnel be accompanied by a system of selection and training that matches the program for flying personnel.

ORGANIZATION FOR RESEARCH AND DEVELOPMENT

WE could not have made this study without becoming aware of a very sensitive problem in Air Force intelligence and reconnaissance: how best to organize and manage its research and development. We understand this is an old and controversial problem, that the Air Force is intimately familiar with it, has studied it and is now set to apply remedies. This Report would be incomplete, however, without a few words on the subject as this Study Group has encountered it.

WE have been told by our briefing and liaison officers that many of the leading proposals in this Report have repeatedly been urged before, in one form and degree or another. Night and bad-weather capability, high-resolution radar, standardized cameras, integrated reconnaissance vehicle "packages" - these and many others have been recurring "musts"

**SUMMARY**

~~CONFIDENTIAL~~

~~SECRET~~

on someone's eager list. But the task of overcoming the enormous inertias of a big military organization remains too obstinate, and these projects do not get done. We raise the question, then, whether it is enough for a group like this merely to make one more series of specific recommendations.

THIS group is not competent to suggest administrative reforms for an Air Force management problem. We can, however, give our warmest support to the efforts now in process to solve it. Two possibilities suggest themselves. First, the organization has become so complex that there is now a lack of close communication between the two groups most immediately concerned: the scientists and industrial producers on the one hand, and the military planners and end users on the other. It has been said that research and development planning is a process of cross-fertilization which operates best when the one group asks in effect, "What do you need?", and the other asks, "What can you produce?" Then, by the interaction of these two elements, a third element is germinated - a military requirement - which neither group could have created by itself. As things now stand, this feedback process is the exception where it should be the rule. Development for intelligence and reconnaissance has to travel a long and hazardous route through military channels, where layers of intermediaries separate the creator from the user, inevitably interposing their own ideas and confusing the process. We need a way to provide clear direction in development planning, and flexible, direct two-way communication between the persons most concerned with development and the persons most concerned with the present and future use of its products.

SECOND, as we see it, there is a need for a more closely knit over-all program control for research and development, with well-defined functional objectives in the intelligence and reconnaissance fields (such as night and bad-weather capability, pre-D-Day capability, etc.). With a clear sense of direction, with management applying itself vigorously to integrated planning, it ought to be possible to come to grips with this vast and complex organizational problem and to correct a dispersal of effort which often confuses essentials with projects of marginal value.

DOES not this all add up to a management problem of formidable size, which, if seized firmly, could prevent important deficiencies in these fields from becoming chronic?

## **SUMMARY**

~~SECRET~~  
~~CONFIDENTIAL~~

CHAPTER 2

REORIENTATION OF THE AIR FORCE INTELLIGENCE EFFORT

In the course of its travels, briefings and discussions, the BEACON HILL Study Group picked up a variety of impressions - some probably reliable, others perhaps questionable. Although most of them concerned the detailed technical ingredients of Air Force intelligence, we occasionally faced up to the type of issue in which perspective is of more consequence than inventiveness - namely, the over-all cast and character of the intelligence effort. In the course of time, we acquired certain convictions about these broader matters. We cannot, of course, prove their validity. But, because they concern problems of great moment, we set them forth in the paragraphs that follow. They are in the nature of "working convictions" - of the sort that colors our judgment on many of the issues raised in this Report.

It appears to us that the big push in the present intelligence effort is in the direction of polishing up our knowledge of the industrial layout and its supporting facilities in the U.S.S.R. Although this program is well designed to further the effectiveness of one of SAC's missions - the "strategic air offensive" - it provides less adequate support for SAC's other two missions - counter-atomic force and retardation. Nor does it do much for the counter-force mission of TAC. It seems to us, therefore, that a redistribution of effort is in order - one that will gear the intelligence program to the realities of the present situation, and pay back fatter dividends for the dollars and manpower invested.

How the present program got fixated on industrial targets is readily understandable. There seem to be two factors involved:

- (1) As of a few years ago, this orientation on strategic targets made sense in terms of relative weapon capabilities;
- (2) Information on strategic targets has been relatively easy to come by.

Let us examine these two factors more closely.

So long as we alone had the atomic bomb, we were in the happy circumstance of being able to ignore the enemy's military potential. If we could strike with atomic bombs while he struck back with TNT, we could be reasonably assured that it would be "no contest." Under ground rules such as these, our power to obliterate the enemy's industrial strength could be decisive, and what the Air Force needed from intelligence, therefore, was strategic target development. But the ground rules are now altered by the fact that both nations are stockpiling atomic bombs, and the game becomes more serious. It reduces to basic weapons against basic weapons and striking force against striking force, and our problem now is to ward off a knockout in round one in order to come out for round two. Information about the enemy's factories would help less at this stage. Information about his military forces would help a lot.

It can be argued that data on military force and basic weapons are hard to get, whereas industrial data are reasonably accessible. So why not make good use of what we have? The danger of this argument is that it might lead us to mistake circularity for progress. We might get ourselves in the position of saying we will use our bombs to hit industry because

~~CONFIDENTIAL~~

~~SECRET~~

~~CONFIDENTIAL~~ ~~SECRET~~

that is what we know most about, and we will ferret out more and more facts about industry because that is what we can hit. Clearly, however, if an enemy knocks out our own striking force while we are trying to smash his rear areas, we may not be able to stand up for round two.

Intelligence in support of counter-atomic operations and retardation is in short supply. A reasonable "guesstimate," derived from the briefing of the BEACON HILL Study Group by the Directorate of Intelligence, is that the operational adequacy of the intelligence coverage for the three classes of targets is as follows: strategic, 90 per cent; counter-atomic, 50 per cent; retardation, 10 per cent. We recognize that these percentages are but rough approximations, and that the figure of 90 percent for strategic coverage does not mean, for example, that 90 per cent of all the problems involved in delivering bombs on strategic targets have been solved. This figure suggests that we at least know the location and general characteristics of about 90 per cent of the potential strategic targets in the U. S. S. R. But regardless of the questions that might be raised about these estimates, their general trend shows in what respects the intelligence program needs attention, and in what areas we might expect the greatest returns from a stepped-up effort.

It is probably reasonable to assume that military intelligence has its own law of diminishing returns. It is relatively easy to get a certain amount of information on a given subject, but no magnitude of effort will ever assemble all the knowledge desired. We never reach 100 per cent operational adequacy. Translated into graphical form, these facts suggest a curve shaped something like that shown in Fig. 2-1. There we see that information on strategic targets may have reached a state of adequacy where a further small increase will cost a lot of work; it is already up to where its curve appears to be flattening out. The other two fields, however, are presumably down on the steep part of their curves where a rich return in information can be had for a relatively small boost in effort. Whatever may be the detailed shape of the curve, the general principle of diminishing returns is certainly operative, and, with only a finite collection capability at our disposal, it is evident that a reallocation of effort is in order.

If a greater part of the Air Force intelligence program is directed at securing counter-force intelligence, with a reduction (if necessary) in the effort devoted to strategic intelligence, there will be a greater rate of return per unit of investment.

Counter-force intelligence is, admittedly, hard to get. How should we go about it? The first step, it seems to us, is one of decision. We must decide what information we want on what subjects in what priority. As outlined in Chapter 3, these decisions could conceivably be achieved in an orderly fashion with the aid of appropriate check lists of intelligence purposes, intelligence data, and intelligence-collection means - all three integrated with the help of numerical-rating procedures. After some such method has established intelligence priorities, the next step is simply to get the intelligence machine locked onto matters of first importance, and off matters of less consequence.

Such a reorientation of effort will properly call forth two modes of implementation.

- (1) Already-existing sources, means and techniques will be

~~CONFIDENTIAL~~

~~SECRET~~

"reinstucted" - reoriented toward the task of higher priority. If the working conviction of the BEACON HILL Study Group holds up under more rigorous scrutiny, this repointing of effort will be in the direction of acquiring more counter-force information, which will then become the focus of attention for all existing agencies and activities: defector program, message analysis, literature analysis, secret agents, friendly travelers, etc.

- (2) Information sources and sensing means will be pushed to high development or discarded according as they promise returns in high-priority intelligence. If what we want most to keep track of is the basic weapons the U. S. S. R. has ready and the basic forces built up around them, we must bear down on sources and sensing techniques that will tell us these things.

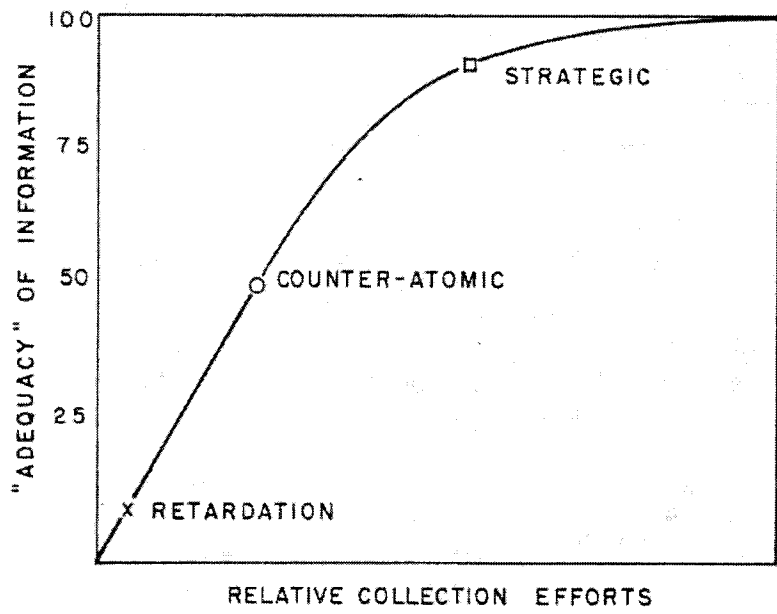

Fig. 2-1. A curve suggesting the manner in which the operational adequacy of intelligence information increases as a function of the effort expended on collection. The positions on the vertical scale of the three labeled points are "guesstimated." Their positions relative to the horizontal scale are not commensurate, i.e., a separate effort scale would be needed for each.

On this point, the Study Group has a particularly strong working conviction. Granted that the defection of the Politburo is a negligible probability, we need a technique, operated by us and at our volition, that will pierce the privacy of the Iron Curtain, and do so without stirring up the political tempest that might attend physical violation of Soviet borders. With these requirements in mind, we have reviewed the basic sensing techniques (cf. check

~~SECRET~~  
~~CONFIDENTIAL~~

list in Table V of Chapter 3), and we conclude that the most promising potential lies with the continuing surveillance of radio and radar emissions. We urge the fullest possible exploitation of this technique. As set forth in Chapter 4, we have in mind here, not the exacting art of message-content analysis, but the simple determination of what emissions take place on what approximate frequencies at what approximate locations. Modern armies must talk by radio on preassigned frequencies. Radio radiates - even through curtains - and therein, we believe, lies our opportunity.

In the face of growing Soviet force capabilities, more intelligence effort is required on the quantity and quality of basic Soviet weapons, and on the composition of basic Soviet forces, at the expense (if necessary) of the effort devoted to industrial intelligence.

~~CONFIDENTIAL~~



~~SECRET~~ CONFIDENTIAL

CHAPTER 3

A METHOD FOR ESTABLISHING THE RELATIVE IMPORTANCE OF INFORMATION

~~CONFIDENTIAL~~

~~SECRET~~

~~SECRET~~

~~CONFIDENTIAL~~

CHAPTER 3

A METHOD FOR ESTABLISHING THE RELATIVE IMPORTANCE OF INFORMATION

A. THE PROBLEM

It appears imperative to the BEACON HILL Study Group that the intelligence activities of the Air Force be guided at all times by a statement of priority of the subjects about which information is sought, together with a corresponding statement of the priority order in which specific information is desired on those subjects. This problem is extremely complex because of the many factors involved and because no one factor is readily susceptible to exact measurement. In spite of this complexity, ways and means must be found to permit us to arrive at a sound solution to the problem of priority of subject and information.

Priorities get set in two ways: by the exercise of human judgment and by default. If explicit judgments and decisions are not forthcoming at the appropriate time, default takes over. Miscellaneous and irrelevant considerations then become the determiners, and we end up with a set of de facto priorities. Difficult as the problem of decision may appear, we believe that it is better to exercise the required judgment than to leave priorities to accident and to the competing interactions of special interests. We believe also that the problem of relative priorities can be solved more easily if those who do the hard thinking necessary to judicious decisions enjoy the benefits of a systematic method. Suggestions for such a method are the subject of this Chapter.

In the field of Air Force intelligence the adoption of a clearly understood system of relative priorities of required information will prevent dispersal of efforts and will lead to higher intelligence returns for the time and money expended.

A consideration of the priority problem leads to the conclusion that four main factors influence the priority of the information sought:

- |   |   |                       |
|---|---|-----------------------|
| (1) The time at which the intelligence is needed      | } | "Use" factors         |
| (2) The end-use for which the intelligence is needed  |   |                       |
| (3) The subject about which the information is sought | } | "Information" factors |
| (4) The nature of the information desired             |   |                       |

What we are looking for is a method by which these four factors, divisible into two groups, may be made to interact in appropriate ways in the determination of intelligence priorities. Since more "mechanical" methods are not available, the specification of the nature of these factors in terms of descriptions and check lists of ingredients, and the weighing of their influence and importance in the priority picture, become of necessity a matter of human judgment. Human judgment about complex issues can usually be made easier with the aid of simple "tools of thought" such as classification and quantification. In the present instance, these tools of thought might well take the form of check lists and numerical-rating procedures.

The establishment of proper priorities is based perforce on human judgment. The exercise of this judgment can be

~~CONFIDENTIAL~~

~~SECRET~~

~~CONFIDENTIAL~~

facilitated by the systematic use of a well-conceived method, involving appropriate check lists and numerical-rating procedures.

#### B. THE TIME FACTOR

The question of the time at which the intelligence is needed involves both real (or calendar) time, and time in relation to D-Day (D-Day minus 30, etc.). It becomes necessary, therefore, to consider these two time scales in any evaluation of priorities. The classical time scale of military planning refers to a hypothetical D-Day, and plans and programs are laid out in relation to that day. Thus we say that final readiness and initial deployment should occur in the period between D-Day minus 30 and D-Day; and we say that the force-programming actions taken at D-Day minus 3 years produce the force available for combat at D-Day. Since all these functions are referred to an unknown D-date, they are not determined in real or calendar time. Prior to D-Day, all functions must go on concurrently on the assumption that the real D-Day will occur sufficiently in the future to permit the action being taken to be effective. It is only at the actual D-Day that military planning time and calendar time are brought into coincidence. Hence, it appears that, for purposes of evaluation, D-Day becomes a critical time fix for the entire military establishment, and we accordingly divide our evaluation into two separate time-periods - pre-D-Day and post-D-Day - on the assumption that we shall at least know which of these two periods we are in, and can govern ourselves accordingly. Our evaluation will therefore be undertaken as two separate and independent evaluations, covering the two major time periods.

(The determination of intelligence priorities must take account of the time at which the intelligence is needed.) The two major time periods, pre-D-Day and post-D-Day, call for two different evaluations of priorities.

#### C. USE CATEGORIES

The end uses served by intelligence are many and varied, and too numerous to list individually. On the other hand, if we are to evolve a system for establishing relative priorities of information, we must categorize end uses in some manner convenient for the evaluation process. It turns out that large numbers of end uses can be assembled into characteristic groupings. For example, intelligence is used importantly to assist in the establishment of our international diplomatic posture, to serve as a basis for programming foreign aid, to guide us in our treaty relations, to serve as a basis for the national budget structure, and to answer a myriad of other specific and detailed purposes. What is required for all these purposes is, roughly, the same kind of information on the same subjects, which means that we can group these purposes under one characteristic heading called "high-level policy and programming." By pursuing this concept, we can establish a relatively small number of end-use groupings to serve as "use" categories in the process of establishing the relative value of information for any one use or for "all uses."

In preparing use categories for the later evaluation of information, we found it inadvisable to try to set up categories all having equal importance. On the other hand, we

~~CONFIDENTIAL~~ 26

~~CONFIDENTIAL~~ ~~SECRET~~

have tried to set up a list of use categories, each of which covers an important and characteristic area of intelligence requirements, and all of which taken together constitute a reasonable approximation to all uses. Then, in order to reflect the relative importance of these various use categories, as they are served by and are dependent on Air Force intelligence, we have assigned to each category a numerical weighting factor proportional to the relative importance of the category.

The list of use categories presented in Tables 3-I(a) and 3-I(b) will serve as an illustration. It is an attempt at a single master list of use categories covering the entire time spectrum from long before D-Day (e. g., research and development programing) to long after D-Day (e. g., target assault). Although this list contains some items peculiar to pre-D-Day conditions and others peculiar to post-D-Day operations, many categories are common to both periods but have different degrees of importance in the two periods. Consequently, weighting factors expressing relative importance have been assigned to each category independently for each of the two time periods. Categories not applicable in a particular time period are simply assigned an importance value of zero for that period. Categories of greatest importance get the highest weightings and those of intermediate importance get lower numbers assigned to them.

It is not suggested that the list of use categories drawn up in this study should be adopted in toto by the Air Force, nor is it suggested that the numerical weighting factors we have assigned are correct. What is suggested is that the procedure employed here offers some promise of helping to solve an extremely complex and difficult problem. The Air Staff might do well to assign to those categories its own numerical weighting factors of relative importance, substantially in the manner outlined.

- ★ The end uses served by intelligence should be grouped into "use categories" and assigned a weighting factor representing their relative importance in different time periods.

#### D. INFORMATION CATEGORIES

With a working list of end uses in hand, we may next consider the kind of intelligence needed to serve these uses. Here we find ourselves again involved with more than a single factor. It appears that the question we are trying to solve might be stated thus: "What information do we want on what subject with what priority?" Since it is the priority we are trying to determine, we can leave it for later resolution in order first to come to grips with the two factors:

- (1) What subject do we wish most to know about?
- (2) What information do we want most about that subject?

As with the end uses, we need to reduce a vast array of subjects to a manageable number of categories. One way to do this is to place in a category all those subjects about which the same information is sought. This permits us to set up a workable number of categories, each embracing many specific subjects about all of which we ask the same questions.

In order to illustrate the nature of this problem, a list of information categories is presented in Table 3-II. It will be noted that under each category the detailed subjects about which we wish to know are listed first, and below them are listed the kinds of information

~~CONFIDENTIAL~~

~~SECRET~~

~~SECRET~~

~~CONFIDENTIAL~~

we seek about all subjects in that category.

Consider as an example a particular category in Table 3-II, say, Transport Systems (Nets), which is one of the four categories included in the group covering Basic Transportation. Under Transport Systems, we find three main subjects about which we want to know something:

- (1) Rail Lines.
- (2) Motor Roads,
- (3) Water Routes.

Each of these is in turn subdivided, but the reason these three main subjects are grouped into a single category is that the same set of questions can be asked about each of them. Thus the nature of the information sought on each of these subjects is listed as:

- (1) Identity data (type, location, etc.).
- (2) Characteristics data (physical and technical layout, system aspects, etc.).
- (3) Activity data (traffic rates, type of use, etc.).
- (4) Defile data (choke points, bridges, tunnels, etc.).

In other words, these questions asked about these subjects constitute what we call an "information category."

The subjects on which intelligence is sought and the nature of the information required on those subjects should be collated into workable "information categories" suitable to the evaluation process.

#### E. THE EVALUATION PROCEDURE

Having arranged the use factors and the information factors involved in the problem into two lists of categories, we are prepared to bring them together in the actual process of evaluating the relative importance of information. The basic notion is to assign a relative-value number, on some suitable scale, to each category of information desired. This is done for each use category separately, and then, by summation of these detailed value assignments, the relative importance of the information categories is established for "all uses."

In our attempt to work out the method, we proceeded as follows (see Tables 3-III and 3-IV). On a large sheet of graph paper, the "use categories" were listed across the top, with one category covering one columnar space. Under each use category we placed the "relative-importance weighting factor" (taken from Table 3-I). Down the left-hand side of the chart, the "information categories" were listed, with one category covering one line space. Each square resulting from one column and one line space then pertained to one use category and one information category. After some experimentation, a scale of one to 20 was adopted and used throughout the detailed build-up of the charts. One use category was considered at a time. The number 20 was assigned to that information category that would be of most value for the use under consideration; the number one was assigned to the information category that would be of least value for the same purpose; and all other blocks in the column were filled in with numbers between one and 20 (in such a way as to reflect the relative importance of the various categories

~~CONFIDENTIAL~~

~~SECRET~~

~~SECRET~~

~~CONFIDENTIAL~~

of information for the purpose under consideration). This process was repeated for each use category. Separate plotting charts were used for the Pre-D-Day Period (Tables 3-III) and the Post-D-Day Period (Table 3-IV); these were filled in independently of each other.

The next step in the procedure was to take account of the weighting factors that reflect the relative importance of the several use categories. The numbers (on the scale of one to 20) entered in the column under each use category were multiplied by the weighting factor at the head of the column in order to combine the two factors - relative importance of information for a given use and relative importance of the use. In this way, we form a basis for establishing the relative importance of information for "all uses."

Then if we add all the weighted numbers for each information category and divide by the sum of the weighting factors (from Table 3-I(a) or 3-I(b), we get a numerical importance rating for each information category for all uses. The relative magnitude of these numbers is a measure of the relative importance - or intelligence value - of the various information categories, and indicates a priority system for our intelligence effort. By referring back to Table II, we can now see what specific subjects are contained in a category of a given priority and what information is wanted about them.

Tables 3-III and 3-IV are sample work sheets illustrative of the form and process suggested. It must be emphasized that the BEACON HILL Study Group does not believe that the use categories or the information categories outlined in Tables 3-I and 3-II are necessarily correct, or that the numbers appearing in Tables 3-I, 3-III, and 3-IV are valid. We are certain that neither the categories nor the numbers reflect the experience and the considered judgment of the Air Staff. What we do believe is that

- (1) A method must be found for the systematic and continuous evaluation of priorities of information desired; and
- (2) The method outlined herein can be adopted and used at once, as a starter, in the evolution of better and sounder procedures for priority evaluation.

In order to see what the outcome of this procedure might look like, let us examine more closely Table 3-III (this is for the pre-D-Day condition). Under each use category is listed a weighting factor giving its relative pre-D-Day importance. Some purposes, like target assault, battle-area mapping, etc., are not relevant for the pre-D-Day period, and their importance is therefore rated zero. As shown by the weighting factors, the purpose or end use served most importantly by intelligence in this time period is judged (by us only, not necessarily by the Air Staff) to be Final Readiness and Deployment. This category is rated 5 in relative importance as an end use for Air Force intelligence. A broad category like High Level Policy and Programing may conceivably be intrinsically more important, but, since it is not so dependent on Air Force intelligence, we have given it a weighting factor of 2. In other words, the weighting factors attempt to reflect both the basic importance of the end uses and the degree to which they are critically dependent on intelligence in the time period under consideration.

Now let us consider a single use category, say, Force Programing (third column in Table 3-III). Its relative importance as an end use for intelligence is judged to be 3. In the column under this category are listed the numerical ratings reflecting the degree to which the information categories, listed at the left, contribute to or serve the purposes of Force

~~SECRET~~ ~~CONFIDENTIAL~~

~~CONFIDENTIAL~~

~~SECRET~~

198

Programing. There we see that two categories, Basic Weapons and Basic Force, are both rated 20. This means that, for the purpose of Force Programing, information on these subjects is judged more important than information on any other subjects. Information on Transport Equipment is judged least important and is rated one. These two numbers, 20 and one, define the two ends of the scale. Categories that are judged to be in importance half-way between the categories represented by 20 and one are assigned the number 10. We find three such assignments in this column. The remaining categories are assigned values in proportion to their apparent relative importance, and the result is a quantitative representation of the priority judgments of the person who made the ratings.

With the entire table filled in, we are in a position to ask what the relative priority of each information category is for all uses combined. Each entry in the table is multiplied by the weighting factor at the top of its column and the resulting products are summed across each row. This sum is then divided by the sum of the weighting factors (27 in this case), and the result is shown in the last column of Table III. There we see that, for all purposes taken together, some categories of information are most important (in this example, Basic Weapons and Basic Force), whereas other categories, such as Transport Equipment and End Products, are of least importance. Other categories fall between these extremes.

A numerical rating should be assigned to the importance of each information category for each of the various end uses served by it. By weighting and averaging these ratings, the over-all relative importance of different kinds of intelligence can be determined.

#### F. THE EVALUATION OF SENSING MEANS

With such a table available (and with a better set of numbers filled in by judges who are more competent in these matters), we are in a position to determine what it is most important to know about what. We can then proceed to other decisions. In particular, we can apply an analogous rating procedure to decide on the relative effectiveness of various "sensing means." In other words, we can compare the available methods for gathering intelligence in terms of their intrinsic effectiveness, weighted by the relative importance of the information they might yield.

We might proceed as follows. We make up other charts like those in Tables III and IV, but we put the Information Categories across the top and Basic Sensing Techniques down the side. An illustrative checklist of these techniques is presented herewith in Table V. As weighting factors for the information categories, we use the numbers in the right-hand columns of Tables III and IV for the pre- and post-D-Day conditions, respectively. Then we consider each information category in turn, and for each category we assign to each sensing technique a numerical rating (on a scale of one to 20) proportional to the ability of that technique to yield data relevant to the given information category. This, like the preceding exercise that resulted in Tables III and IV, is an exacting intellectual exercise and must be performed by those most knowledgeable and competent in the field.

Finally, if it is desired to intercompare the various sensing means in terms

~~CONFIDENTIAL~~

~~SECRET~~

of their capacity to yield important information on important subjects, the numerical ratings in the tables may be multiplied by the appropriate weighting factor (importance-of-information category as derived from Tables 3-III or 3-IV), and the results for each sensing means may be summed up and divided by the sum of the weighting factors. The resulting numbers then provide a guide to the relative importance of different sensing means for the production of Air Force intelligence.

Time did not permit the BEACON HILL Study Group to carry through an illustrative example of how the complete table of priority ratings for sensing techniques might look, but we can foresee no insurmountable difficulties in the task. Needless to say, however, not only will such a priority-generating procedure need to be worked out in the perspective of all the relevant factors currently operating, but it will need to be periodically revised in the light of new developments in the state of the art and new exigencies in the international situation.

The numerical procedure of priority rating may be extended to the evaluation of the relative effectiveness of various sensing means.

So much for what we conceive to be the basic nature of a possible method for establishing the relative importance of information and the means of obtaining it. The procedure outlined can be thought of as an aid to the exercise of judgment - "thinking charts" we sometimes call them. Admittedly, the numbers in these charts and tables can be no better than the thought and wisdom of the one who constructs them and fills them in. Conscientiously completed, however, the tables have the obvious merit of revealing in a quantitative fashion the real nature of the opinions and convictions of the rater. It would be preferable, of course, if there were a method that did not rely on human judgment, but there is none; and in our opinion there can never be a method of priority assignments that dispenses with human thought. The human mind is still our best integrating device, especially when the input is a batch of complex, interacting, multifaceted factors - the stuff that priority judgments are made of. What we need is to figure out gimmicks, props, and procedures that will help the mind to do its integrating more reliably.

#### G. FURTHER CONSIDERATIONS

Although much more could be said about the difficulties and pitfalls of a method such as is here proposed, we should like to comment on two of the more obvious aspects of the business.

##### 1. Categories

Lists of end uses, kinds of information, and means of acquiring it do not come ready-made. They have to be assembled and refined into manageable groupings and categories by careful surveys of the relevant facts. The conclusions derivable from a chart like Table 3-III are clearly sensitive to the nature of the categories appearing along the borders. The categories in turn must be capable of specification in concrete detail, as we have tried to illustrate in our partial breakdown of the "information categories" (Table 3-II). We feel that some of the categories we might have used, such as "Soviet Intentions" as an information category, or "Prevention of Technological Surprise" as an end-use category, cannot readily be



~~SECRET~~

~~CONFIDENTIAL~~

pinned down to a list of concrete components. Technological surprise is automatically prevented if we have intelligence adequate to serve such other use categories as Research and Development, Determination of Assault Conditions, Final Readiness and Deployment, etc. These and other end uses are not properly served unless we know about Soviet technical achievements, current and forthcoming; and if we know these achievements we are not going to be very much surprised technologically.

Soviet Intentions, as an information category, seems to us to have the disadvantage that it is not a set of facts but a series of deductions. The verifiable facts consist of what the Soviets have and what they do with it. What goes on in their minds - their hopes, fears, and ambitions - may be of psychiatric interest, but these "psychic contents" need concern us only as they manifest themselves in actions. If a man sticks a gun in our ribs, we deduce his intentions and take action without worrying about what really goes on in his mind. Maybe he thinks he is only joking, but we are justified in our self-defense. Wars have been started by people who did not "intend" to fight, and would-be Napoleons have "intended" to conquer the world without having the arms to do it.

No doubt, the Soviets "intend" what most peoples have always intended:

- (1) To survive.
- (2) To keep what they have,
- (3) To grow in strength and prosperity,
- (4) To be stronger than their potential enemies,
- (5) To persuade others of their good qualities,
- (6) To fight if necessary.

These intentions we can take for granted - for us, for the Soviets, and for most other nations - but what makes one nation's so-called intentions interesting and another nation's of little concern is the military force available to back them up. Argentina may "intend" to dominate the Western Hemisphere, but we will probably not pivot our policies around the Argentine issue until intelligence discloses that the Argentine is bristling with airplanes, tanks and munitions, backed by a productive technology.

We start, then, with facts about weapons, munitions, forces, production facilities, transport facilities, and the like, and from these facts we deduce intentions - implementable, unignorable intentions. But we start with facts, not with mental attitudes.

## 2. Numerical ratings

The use of the proposed method calls for the assignment of numbers to things that cannot be measured by yardsticks of the ordinary sort. How do we attach numbers to something like relative importance? Problems in this field have been extensively explored in psychological laboratories,\* and the outcome can be most succinctly expressed by saying, "you put numbers on such things simply by putting them on." We all use adjectives freely - good, bad, better, worse, important, top-priority, A-1, snafu, etc. - but we seldom try to translate

\*For a fuller treatment of these problems, and of scaling procedures in general, see S. S. Stevens, Handbook of Experimental Psychology, Chapter I (New York, Wiley, 1951).

~~CONFIDENTIAL~~

~~SECRET~~

~~CONFIDENTIAL~~ [REDACTED]

these adjectives into positions on a scale of something or other. Being unaccustomed to it, we may tend to think it is impossible, but a little practice with the procedure soon shows that it is quite feasible - and often very revealing. When we must struggle with the description of the complexities in an area like that depicted in Tables III and IV, it is far easier to wrestle with numbers than with adjectives.

The choice of a scale for rating relative importance is basically arbitrary, but certain considerations apply. It will be noted that we chose a scale from 0 to 5 for the weighting factors attached to the end-use categories of Tables 3-I(a), 3-I(b). This scale needs a zero to reflect the fact that some uses are not operative pre-D-Day and that some are inconsequential post-D-Day. For the rest of this scale, we can get along with small numbers because the differences among the use categories are not large. As a matter of fact, we first set out to choose categories that were all of equal importance, but it did not prove practicable, and we had to resort to weighting factors. These factors have the advantage, of course, that they can be altered as conditions change.

For the main job of rating the information categories we chose the scale one to 20 simply because we got ourselves accustomed to using it. The number of categories on each side of Tables 3-III and 3-IV is not far from 20 and, in our earlier explorings with different procedures, we had tried out the method of setting the categories in a rank order by giving each a different number starting with one for the least important and going up. This got us started using numbers from one to 20. In general, however, two considerations ought to apply: the scale should not have so few numbers on it that the rater sometimes feels that a category really lies half way between two values, say between 2 and 3; and the scale should not have so many numbers that most of them never get used because the rater cannot distinguish so finely. The proper length of scale for a given problem can best be determined by trial, and by what the rater likes to work with. Remember that the only point to the rating procedure is to get a true reflection of the rater's considered judgment, and that the rater needs every "break" we can give him.

As pointed out above, we first explored the possibilities of using the method of rank order, in which categories are merely arranged in order of increasing or decreasing importance. This leads to what is called an ordinal scale. This scale is sometimes easier to achieve, but it is a "weaker" type of scale and has the disadvantage that simple arithmetic operations, such as averaging, are not applicable to it. A category rated 16 may be many times more important than the next below it, but the one below it would still be rated 15 on an ordinal scale.

We therefore went to an interval scale. With 20 assigned to the most important category and one to the least important, an interval scale becomes possible in principle provided the number 10 can be assigned to the category (if there is one) that appears to lie halfway between. (Actually, the mid-point between one and 20 is 10.5, but we doubt that the hair needs to be split that finely.) Intermediate numbers then get assigned to intermediate categories in a manner that reflects the apparent size of the intervals between them.

We have used one rather than zero as the bottom of the scale, on the assumption that no category of information would ever be completely useless. Whether this

~~CONFIDENTIAL~~

~~SECRET~~

~~CONFIDENTIAL~~

practice introduces some minor degree of distortion would need to be explored by more extensive analysis than we have had time for. Indeed, there are many details that need further exploration, but it is to be hoped that a concern for subtleties will not be allowed to obscure the broad purpose of the method, which is simply to provide a rational basis for putting first things first.

~~SECRET~~

~~CONFIDENTIAL~~

~~SECRET~~

~~CONFIDENTIAL~~

TABLE I

USE CATEGORIES

With Weighting Factors Giving Relative Importance

(a)  
Pre-D-Day

Use	Weighting factor
1. High-level policy and programing	2
2. War planning	2
3. Force programing	3
4. Research and Development programing	4
5. Determination of assault conditions	1
6. Final readiness and deployment	5
7. Area development (Strat. Air Offensive)	1
8. Target development (Strat. Air Offensive)	2
9. Target assault (Strat. Air Offensive)	0
10. Air Force deployment development	2
11. Counter air force target development	2
12. Counter air force target assault	0
13. Ground force deployment development	2
14. Tactical target and area development	1
15. Tactical target assault	0
16. Moving target development and assault	0
17. Battle area mapping	0
Sum of Weighting Factors	27

(b)  
Post-D-Day

Use	Weighting factor
1. High-level policy and programing	} 1
2. War planning	
3. Force programing	
4. Research and Development programing	2
5. Determination of assault conditions	0
6. Final readiness and deployment	0
7. Area development (Strat. Air Offensive)	2
8. Target development (Strat. Air Offensive)	3
9. Target assault (Strat. Air Offensive)	2
10. Air Force deployment development	5
11. Counter Air Force target development	4
12. Counter Air Force target assault	3
13. Ground force deployment development	4
14. Tactical target and area development	3
15. Tactical target assault	2
16. Moving target development and assault	1
17. Battle area mapping	1
Sum of Weighting Factors	33

~~CONFIDENTIAL~~

~~SECRET~~

CONFIDENTIAL

CONFIDENTIAL

TABLE II  
GROUP I - MILITARY CATEGORIES

CONFIDENTIAL

CONFIDENTIAL

CONFIDENTIAL

CONFIDENTIAL

A - Ground Equipment

1. COMBAT VEHICLES

- a. By Type
  - (1) Ground Tank, Prototype and
  - (2) Reconnaissance
  - (3) Assault Vehicle
  - (4) "Combat Vehicle"
  - (5) Reconnaissance Vehicle
  - (6) Amphibious Vehicle
- b. By Name
  - (1) Unmanned
  - (2) Other name, official
  - (3) Other name
- c. By Function
  - (1) Armored
  - (2) Reconnaissance
  - (3) Amphibious
- d. By Component
  - (1) Chassis or other main
  - (2) Wheel and tire
  - (3) Assembly of drive

2. MONTRES

- a. By Application
  - (1) Time of day setting
  - (2) Identification
- b. By Operating Error
  - (1) Alarm
  - (2) Other name, vehicle
  - (3) Other
- c. By Accuracy
  - (1) Accuracy of operation
  - (2) Accuracy of time
  - (3) Other
- d. By Type
  - (1) Analog
  - (2) Digital
  - (3) Mechanical
  - (4) Electronic
  - (5) Other

3. WEAPONS

- a. By Method
  - (1) Automatic
  - (2) Semi-automatic
  - (3) Manual
  - (4) Other
- b. By Type
  - (1) Assault rifle
  - (2) Anti-aircraft rifle
  - (3) Rifle
  - (4) Machine gun
  - (5) Submachine gun
  - (6) Pistol
  - (7) Shotgun
  - (8) Other
- c. By Name
  - (1) M1 Garand
  - (2) M16
  - (3) M14
  - (4) M1918
  - (5) M1903
  - (6) M1905
  - (7) M1919
  - (8) M1921
  - (9) M1927
  - (10) M1935
  - (11) M1945
  - (12) M1947
  - (13) M1951
  - (14) M1952
  - (15) M1953
  - (16) M1954
  - (17) M1955
  - (18) M1956
  - (19) M1957
  - (20) M1958
  - (21) M1959
  - (22) M1960
  - (23) M1961
  - (24) M1962
  - (25) M1963
  - (26) M1964
  - (27) M1965
  - (28) M1966
  - (29) M1967
  - (30) M1968
  - (31) M1969
  - (32) M1970
  - (33) M1971
  - (34) M1972
  - (35) M1973
  - (36) M1974
  - (37) M1975
  - (38) M1976
  - (39) M1977
  - (40) M1978
  - (41) M1979
  - (42) M1980
  - (43) M1981
  - (44) M1982
  - (45) M1983
  - (46) M1984
  - (47) M1985
  - (48) M1986
  - (49) M1987
  - (50) M1988
  - (51) M1989
  - (52) M1990
  - (53) M1991
  - (54) M1992
  - (55) M1993
  - (56) M1994
  - (57) M1995
  - (58) M1996
  - (59) M1997
  - (60) M1998
  - (61) M1999
  - (62) M2000
  - (63) M2001
  - (64) M2002
  - (65) M2003
  - (66) M2004
  - (67) M2005
  - (68) M2006
  - (69) M2007
  - (70) M2008
  - (71) M2009
  - (72) M2010
  - (73) M2011
  - (74) M2012
  - (75) M2013
  - (76) M2014
  - (77) M2015
  - (78) M2016
  - (79) M2017
  - (80) M2018
  - (81) M2019
  - (82) M2020
  - (83) M2021
  - (84) M2022
  - (85) M2023
  - (86) M2024
  - (87) M2025
  - (88) M2026
  - (89) M2027
  - (90) M2028
  - (91) M2029
  - (92) M2030
  - (93) M2031
  - (94) M2032
  - (95) M2033
  - (96) M2034
  - (97) M2035
  - (98) M2036
  - (99) M2037
  - (100) M2038
  - (101) M2039
  - (102) M2040
  - (103) M2041
  - (104) M2042
  - (105) M2043
  - (106) M2044
  - (107) M2045
  - (108) M2046
  - (109) M2047
  - (110) M2048
  - (111) M2049
  - (112) M2050
  - (113) M2051
  - (114) M2052
  - (115) M2053
  - (116) M2054
  - (117) M2055
  - (118) M2056
  - (119) M2057
  - (120) M2058
  - (121) M2059
  - (122) M2060
  - (123) M2061
  - (124) M2062
  - (125) M2063
  - (126) M2064
  - (127) M2065
  - (128) M2066
  - (129) M2067
  - (130) M2068
  - (131) M2069
  - (132) M2070
  - (133) M2071
  - (134) M2072
  - (135) M2073
  - (136) M2074
  - (137) M2075
  - (138) M2076
  - (139) M2077
  - (140) M2078
  - (141) M2079
  - (142) M2080
  - (143) M2081
  - (144) M2082
  - (145) M2083
  - (146) M2084
  - (147) M2085
  - (148) M2086
  - (149) M2087
  - (150) M2088
  - (151) M2089
  - (152) M2090
  - (153) M2091
  - (154) M2092
  - (155) M2093
  - (156) M2094
  - (157) M2095
  - (158) M2096
  - (159) M2097
  - (160) M2098
  - (161) M2099
  - (162) M2100
  - (163) M2101
  - (164) M2102
  - (165) M2103
  - (166) M2104
  - (167) M2105
  - (168) M2106
  - (169) M2107
  - (170) M2108
  - (171) M2109
  - (172) M2110
  - (173) M2111
  - (174) M2112
  - (175) M2113
  - (176) M2114
  - (177) M2115
  - (178) M2116
  - (179) M2117
  - (180) M2118
  - (181) M2119
  - (182) M2120
  - (183) M2121
  - (184) M2122
  - (185) M2123
  - (186) M2124
  - (187) M2125
  - (188) M2126
  - (189) M2127
  - (190) M2128
  - (191) M2129
  - (192) M2130
  - (193) M2131
  - (194) M2132
  - (195) M2133
  - (196) M2134
  - (197) M2135
  - (198) M2136
  - (199) M2137
  - (200) M2138
  - (201) M2139
  - (202) M2140
  - (203) M2141
  - (204) M2142
  - (205) M2143
  - (206) M2144
  - (207) M2145
  - (208) M2146
  - (209) M2147
  - (210) M2148
  - (211) M2149
  - (212) M2150
  - (213) M2151
  - (214) M2152
  - (215) M2153
  - (216) M2154
  - (217) M2155
  - (218) M2156
  - (219) M2157
  - (220) M2158
  - (221) M2159
  - (222) M2160
  - (223) M2161
  - (224) M2162
  - (225) M2163
  - (226) M2164
  - (227) M2165
  - (228) M2166
  - (229) M2167
  - (230) M2168
  - (231) M2169
  - (232) M2170
  - (233) M2171
  - (234) M2172
  - (235) M2173
  - (236) M2174
  - (237) M2175
  - (238) M2176
  - (239) M2177
  - (240) M2178
  - (241) M2179
  - (242) M2180
  - (243) M2181
  - (244) M2182
  - (245) M2183
  - (246) M2184
  - (247) M2185
  - (248) M2186
  - (249) M2187
  - (250) M2188
  - (251) M2189
  - (252) M2190
  - (253) M2191
  - (254) M2192
  - (255) M2193
  - (256) M2194
  - (257) M2195
  - (258) M2196
  - (259) M2197
  - (260) M2198
  - (261) M2199
  - (262) M2200
  - (263) M2201
  - (264) M2202
  - (265) M2203
  - (266) M2204
  - (267) M2205
  - (268) M2206
  - (269) M2207
  - (270) M2208
  - (271) M2209
  - (272) M2210
  - (273) M2211
  - (274) M2212
  - (275) M2213
  - (276) M2214
  - (277) M2215
  - (278) M2216
  - (279) M2217
  - (280) M2218
  - (281) M2219
  - (282) M2220
  - (283) M2221
  - (284) M2222
  - (285) M2223
  - (286) M2224
  - (287) M2225
  - (288) M2226
  - (289) M2227
  - (290) M2228
  - (291) M2229
  - (292) M2230
  - (293) M2231
  - (294) M2232
  - (295) M2233
  - (296) M2234
  - (297) M2235
  - (298) M2236
  - (299) M2237
  - (300) M2238
  - (301) M2239
  - (302) M2240
  - (303) M2241
  - (304) M2242
  - (305) M2243
  - (306) M2244
  - (307) M2245
  - (308) M2246
  - (309) M2247
  - (310) M2248
  - (311) M2249
  - (312) M2250
  - (313) M2251
  - (314) M2252
  - (315) M2253
  - (316) M2254
  - (317) M2255
  - (318) M2256
  - (319) M2257
  - (320) M2258
  - (321) M2259
  - (322) M2260
  - (323) M2261
  - (324) M2262
  - (325) M2263
  - (326) M2264
  - (327) M2265
  - (328) M2266
  - (329) M2267
  - (330) M2268
  - (331) M2269
  - (332) M2270
  - (333) M2271
  - (334) M2272
  - (335) M2273
  - (336) M2274
  - (337) M2275
  - (338) M2276
  - (339) M2277
  - (340) M2278
  - (341) M2279
  - (342) M2280
  - (343) M2281
  - (344) M2282
  - (345) M2283
  - (346) M2284
  - (347) M2285
  - (348) M2286
  - (349) M2287
  - (350) M2288
  - (351) M2289
  - (352) M2290
  - (353) M2291
  - (354) M2292
  - (355) M2293
  - (356) M2294
  - (357) M2295
  - (358) M2296
  - (359) M2297
  - (360) M2298
  - (361) M2299
  - (362) M2300
  - (363) M2301
  - (364) M2302
  - (365) M2303
  - (366) M2304
  - (367) M2305
  - (368) M2306
  - (369) M2307
  - (370) M2308
  - (371) M2309
  - (372) M2310
  - (373) M2311
  - (374) M2312
  - (375) M2313
  - (376) M2314
  - (377) M2315
  - (378) M2316
  - (379) M2317
  - (380) M2318
  - (381) M2319
  - (382) M2320
  - (383) M2321
  - (384) M2322
  - (385) M2323
  - (386) M2324
  - (387) M2325
  - (388) M2326
  - (389) M2327
  - (390) M2328
  - (391) M2329
  - (392) M2330
  - (393) M2331
  - (394) M2332
  - (395) M2333
  - (396) M2334
  - (397) M2335
  - (398) M2336
  - (399) M2337
  - (400) M2338
  - (401) M2339
  - (402) M2340
  - (403) M2341
  - (404) M2342
  - (405) M2343
  - (406) M2344
  - (407) M2345
  - (408) M2346
  - (409) M2347
  - (410) M2348
  - (411) M2349
  - (412) M2350
  - (413) M2351
  - (414) M2352
  - (415) M2353
  - (416) M2354
  - (417) M2355
  - (418) M2356
  - (419) M2357
  - (420) M2358
  - (421) M2359
  - (422) M2360
  - (423) M2361
  - (424) M2362
  - (425) M2363
  - (426) M2364
  - (427) M2365
  - (428) M2366
  - (429) M2367
  - (430) M2368
  - (431) M2369
  - (432) M2370
  - (433) M2371
  - (434) M2372
  - (435) M2373
  - (436) M2374
  - (437) M2375
  - (438) M2376
  - (439) M2377
  - (440) M2378
  - (441) M2379
  - (442) M2380
  - (443) M2381
  - (444) M2382
  - (445) M2383
  - (446) M2384
  - (447) M2385
  - (448) M2386
  - (449) M2387
  - (450) M2388
  - (451) M2389
  - (452) M2390
  - (453) M2391
  - (454) M2392
  - (455) M2393
  - (456) M2394
  - (457) M2395
  - (458) M2396
  - (459) M2397
  - (460) M2398
  - (461) M2399
  - (462) M2400
  - (463) M2401
  - (464) M2402
  - (465) M2403
  - (466) M2404
  - (467) M2405
  - (468) M2406
  - (469) M2407
  - (470) M2408
  - (471) M2409
  - (472) M2410
  - (473) M2411
  - (474) M2412
  - (475) M2413
  - (476) M2414
  - (477) M2415
  - (478) M2416
  - (479) M2417
  - (480) M2418
  - (481) M2419
  - (482) M2420
  - (483) M2421
  - (484) M2422
  - (485) M2423
  - (486) M2424
  - (487) M2425
  - (488) M2426
  - (489) M2427
  - (490) M2428
  - (491) M2429
  - (492) M2430
  - (493) M2431
  - (494) M2432
  - (495) M2433
  - (496) M2434
  - (497) M2435
  - (498) M2436
  - (499) M2437
  - (500) M2438
  - (501) M2439
  - (502) M2440
  - (503) M2441
  - (504) M2442
  - (505) M2443
  - (506) M2444
  - (507) M2445
  - (508) M2446
  - (509) M2447
  - (510) M2448
  - (511) M2449
  - (512) M2450
  - (513) M2451
  - (514) M2452
  - (515) M2453
  - (516) M2454
  - (517) M2455
  - (518) M2456
  - (519) M2457
  - (520) M2458
  - (521) M2459
  - (522) M2460
  - (523) M2461
  - (524) M2462
  - (525) M2463
  - (526) M2464
  - (527) M2465
  - (528) M2466
  - (529) M2467
  - (530) M2468
  - (531) M2469
  - (532) M2470
  - (533) M2471
  - (534) M2472
  - (535) M2473
  - (536) M2474
  - (537) M2475
  - (538) M2476
  - (539) M2477
  - (540) M2478
  - (541) M2479
  - (542) M2480
  - (543) M2481
  - (544) M2482
  - (545) M2483
  - (546) M2484
  - (547) M2485
  - (548) M2486
  - (549) M2487
  - (550) M2488
  - (551) M2489
  - (552) M2490
  - (553) M2491
  - (554) M2492
  - (555) M2493
  - (556) M2494
  - (557) M2495
  - (558) M2496
  - (559) M2497
  - (560) M2498
  - (561) M2499
  - (562) M2500
  - (563) M2501
  - (564) M2502
  - (565) M2503
  - (566) M2504
  - (567) M2505
  - (568) M2506
  - (569) M2507
  - (570) M2508
  - (571) M2509
  - (572) M2510
  - (573) M2511
  - (574) M2512
  - (575) M2513
  - (576) M2514
  - (577) M2515
  - (578) M2516
  - (579) M2517
  - (580) M2518
  - (581) M2519
  - (582) M2520
  - (583) M2521
  - (584) M2522
  - (585) M2523
  - (586) M2524
  - (587) M2525
  - (588) M2526
  - (589) M2527
  - (590) M2528
  - (591) M2529
  - (592) M2530
  - (593) M2531
  - (594) M2532
  - (595) M2533
  - (596) M2534
  - (597) M2535
  - (598) M2536
  - (599) M2537
  - (600) M2538
  - (601) M2539
  - (602) M2540
  - (603) M2541
  - (604) M2542
  - (605) M2543
  - (606) M2544
  - (607) M2545
  - (608) M2546
  - (609) M2547
  - (610) M2548
  - (611) M2549
  - (612) M2550
  - (613) M2551
  - (614) M2552
  - (615) M2553
  - (616) M2554
  - (617) M2555
  - (618) M2556
  - (619) M2557
  - (620) M2558
  - (621) M2559
  - (622) M2560
  - (623) M2561
  - (624) M2562
  - (625) M2563
  - (626) M2564
  - (627) M2565
  - (628) M2566
  - (629) M2567
  - (630) M2568
  - (631) M2569
  - (632) M2570
  - (633) M2571
  - (634) M2572
  - (635) M2573
  - (636) M2574
  - (637) M2575
  - (638) M2576
  - (639) M2577
  - (640) M2578
  - (641) M2579
  - (642) M2580
  - (643) M2581
  - (644) M2582
  - (645) M2583
  - (646) M2584
  - (647) M2585
  - (648) M2586
  - (649) M2587
  - (650) M2588
  - (651) M2589
  - (652) M2590
  - (653) M2591
  - (654) M2592
  - (655) M2593
  - (656) M2594
  - (657) M2595
  - (658) M2596
  - (659) M2597
  - (660) M2598
  - (661) M2599
  - (662) M2600
  - (663) M2601
  - (664) M2602
  - (665) M2603
  - (666) M2604
  - (667) M2605
  - (668) M2606
  - (669) M2607
  - (670) M2608
  - (671) M2609
  - (672) M2610
  - (673) M2611
  - (674) M2612
  - (675) M2613
  - (676) M2614
  - (677) M2615
  - (678) M2616
  - (679) M2617
  - (680) M2618
  - (681) M2619
  - (682) M2620
  - (683) M2621
  - (684) M2622
  - (685) M2623
  - (686) M2624
  - (687) M2625
  - (688) M2626
  - (689) M2627
  - (690) M2628
  - (691) M2629
  - (692) M2630
  - (693) M2631
  - (694) M2632
  - (695) M2633
  - (696) M2634
  - (697) M2635
  - (698) M2636
  - (699) M2637
  - (700) M2638
  - (701) M2639
  - (702) M2640
  - (703) M2641
  - (704) M2642
  - (705) M2643
  - (706) M2644
  - (707) M2645
  - (708) M2646
  - (709) M2647
  - (710) M2648
  - (711) M2649
  - (712) M2650
  - (713) M2651
  - (714) M2652
  - (715) M2653
  - (716) M2654
  - (717) M2655
  - (718) M2656
  - (719) M2657
  - (720) M2658
  - (721) M2659
  - (722) M2660
  - (723) M2661
  - (724) M2662
  - (725) M2663
  - (726) M2664
  - (727) M2665
  - (728) M2666
  - (729) M2667
  - (730) M2668
  - (731) M2669
  - (732) M2670
  - (733) M2671
  - (734) M2672
  - (735) M2673
  - (736) M2674
  - (737) M2675
  - (738) M2676
  - (739) M2677
  - (740) M2678
  - (741) M2679
  - (742) M2680
  - (743) M2681
  - (744) M2682
  - (745) M2683
  - (746) M2684
  - (747) M2685
  - (748) M2686
  - (749) M2687
  - (750) M26

CONFIDENTIAL

CONFIDENTIAL

TABLE 1  
GROUP B - INDUSTRIAL CATEGORIES

A - End-Product Facilities

Subject to which information is sought

1. END-PRODUCT INSTALLATIONS
  - a. Basic Weapons
    - (1) Sub-1, L-2
  - b. Weapons Guidance and Control
    - (1) Sub-1, L-2
  - c. Other Military Equipment
    - (1) Equipment to be developed
    - (2) Basic equipment of existing plants
      - (a) Sub-1, L-2
    - (3) Basic equipment of weapons plants
      - (a) Sub-1, L-2
    - (4) Other major items of equipment
      - (a) Other equipment
2. SUPPLIER FACILITIES TO MILITARY
  - (1) To whom supply is made
  - (2) Other supplies
3. OTHER SUPPLIES
  - (1) To whom supply
  - (2) Other

Name of the information sought on each of the subjects above

1. GENERAL DATA
  - a. End-Product Processed
  - b. Process involved
    - (1) Design and development
    - (2) Assembly
    - (3) Production
    - (4) Maintenance or repair
  - c. Location
    - (1) Street
    - (2) Local address
  - d. Importance (general)
    - (1) Use
    - (2) Material

2. CHARACTERISTIC DATA

- a. Physical
  - (1) Layout plan
  - (2) Equipment employed
  - (3) Subprocesses employed
- b. Technical
  - (1) Design and development
  - (2) Assembly
  - (3) Production
  - (4) Maintenance or repair
- c. Structural
  - (1) Plans of construction
  - (2) Materials used
- d. Transportation mode
  - (1) Route
  - (2) Mode

3. ACTIVITY DATA

- a. Production rates
  - (1) Present
  - (2) Past
- b. Consumption rates
  - (1) Subprocesses
  - (2) Components
  - (3) Materials
  - (4) Power (fuel) not stated
- c. Manpower use
  - (1) Technical
  - (2) Other

B - Waste Materials Facilities

Subject to which information is sought

1. REFINING FACILITIES
  - a. Smelters
    - (1) Lead
    - (2) Copper
    - (3) Nickel
    - (4) Zinc
  - b. Refractories
    - (1) Chemical reduction plants
    - (2) Chemical synthesis plants
    - (3) Metallic ore reduction
    - (4) Coke ovens
    - (5) Other

2. STORAGE AND DISTRIBUTION FACILITIES

- a. Liquid and gases
  - (1) Acetylene
  - (2) Nitrogen
  - (3) Oxygen
  - (4) Other
- b. Gas and steam
- c. Tanks
  - (1) Acetylene
  - (2) Gas
- d. Turbines
  - (1) Industrial
  - (2) Other
- e. Hoists

3. FINISHING FACILITIES

- a. Metal Mills
  - (1) Rolling mills
  - (2) Drawing mills
  - (3) Slabs
  - (4) Castings
  - (5) Castings mills
  - (6) Other
- b. Turbine Mills
  - (1) Other items
  - (2) Turbine plants
  - (3) Other
- c. Building material plants
  - (1) Brick
  - (2) Tile plants
  - (3) Refractory brick plants
  - (4) Other

Name of the information sought on each of the subjects above

4. IDENTITY DATA

- a. Product handled
- b. Name of the facility
- c. Location
  - (1) Street
  - (2) Local address
- d. Importance
  - (1) Use
  - (2) Material

5. CHARACTERISTIC DATA

- a. Physical
  - (1) Layout plan
  - (2) Equipment employed
  - (3) Subprocesses employed
- b. Technical
  - (1) Design and development
  - (2) Assembly
  - (3) Production
  - (4) Maintenance or repair
- c. Structural
  - (1) Plans of construction
  - (2) Materials used
  - (3) Power (fuel) not stated
- d. Capacity

6. ACTIVITY DATA

- a. Production (handling) rates
  - (1) Present
  - (2) Past
- b. Consumption rates
  - (1) Subprocesses
  - (2) Components
  - (3) Materials
  - (4) Power (fuel) not stated
- c. Manpower use
  - (1) Technical
  - (2) Other

C - Basic Machine Facilities

Subject to which information is sought

1. ELECTRIC POWER FACILITIES
  - a. Generating plants
    - (1) Water power
    - (2) Non-steam power
    - (3) Other
  - b. Sub-stations
  - c. Booster stations
  - d. Transmission lines
    - (1) High voltage
    - (2) Non-steam lines
    - (3) Other
  - e. Local distributing centers
    - (1) Oil
    - (2) Steam
    - (3) Other

2. WATER SUPPLY FACILITIES

- a. Dams and structures
  - (1) High capacity
  - (2) Low capacity
  - (3) Other
- b. Pumping plants
  - (1) High capacity
  - (2) Low capacity
  - (3) Other
- c. Trenches
  - (1) High capacity
  - (2) Low capacity
  - (3) Other
- d. Pipe lines
  - (1) High capacity
  - (2) Low capacity
  - (3) Other

3. GAS FACILITIES

- a. Gas storage tanks
- b. Generating plants
- c. Pumping plants
- d. Pipe lines

4. TELEPHONE & TELEGRAPH FACILITIES

- a. Long-distance switching centers
- b. Central offices
- c. Long telephonic lines
- d. Local central offices
- e. Other lines

Name of the information sought on each of the subjects above

5. IDENTITY DATA

- a. Product handled
- b. Name of the facility
- c. Location
  - (1) Street
  - (2) Local address
- d. Importance
  - (1) Use
  - (2) Material

6. CHARACTERISTIC DATA

- a. Physical
  - (1) Layout plan
  - (2) Equipment employed
  - (3) Subprocesses employed
- b. Technical
  - (1) Design and development
  - (2) Assembly
  - (3) Production
  - (4) Maintenance or repair
- c. Structural
  - (1) Plans of construction
  - (2) Materials used
  - (3) Power (fuel) not stated
- d. Capacity

7. ACTIVITY DATA

- a. Production (manufactured) rates
  - (1) Present
  - (2) Past
- b. Consumption rates
  - (1) Subprocesses
  - (2) Components
  - (3) Materials
  - (4) Power (fuel) not stated
- c. Manpower use
  - (1) Technical
  - (2) Other

D - End-Products

Subject to which information is sought

1. MILITARY EQUIPMENT (see entry)
2. MILITARY SUPPLIES (see entry)
3. OTHER EQUIPMENT
  - a. New equipment
  - b. Special use equipment
  - c. Common use equipment
4. OTHER SHIPPLERS
  - a. New materials
  - b. New materials
  - c. Basic materials

5. BASIC MATERIALS

- a. Fuels
  - (1) Petroleum Products
  - (2) Synthetic fuels
  - (3) Coal products
  - (4) Wood products
  - (5) Other fuels
- b. Metals
  - (1) Light metals
    - (a) Aluminum
    - (b) Magnesium
    - (c) Other
  - (2) Iron metals
  - (3) Non-ferrous
    - (a) Special steels
    - (b) Other metals
    - (c) Steel
    - (d) Other metals
- c. Chemicals
- d. Non-metallic structural materials
  - (1) Various structural materials
  - (2) Building construction
  - (3) Glass materials
- e. Rubber and rubber substitutes
- f. Miscellaneous materials
  - (1) Plastics
  - (2) Ceramics
  - (3) Textiles
  - (4) Other

Name of the information sought on each of the subjects above

6. IDENTITY DATA

- a. Product
- b. Use
- c. Purpose

7. CHARACTERISTIC DATA

- a. Physical
  - (1) Appearance and identification
  - (2) Composition
  - (3) Performance quality
- b. Technical
  - (1) Performance
  - (2) Specifications
  - (3) Technical support
  - (4) Standards
  - (5) Drawings
- c. Control coding (name plate)

8. ENVIRONMENT DATA

- a. Specific use
  - (1) Present
  - (2) Past
- b. Basis for distribution
  - (1) Basis for production
  - (2) Basis for construction

9 - Industrial Processes

Checked out to be prepared in this category

10 - Other Materials

Checked out to be prepared in this category

CONFIDENTIAL

CONFIDENTIAL

p. 35 (6)

TABLE II

GROUP II - BASIC TRANSPORTATION CATEGORIES

A - Transport Systems (Units)

Indicate in which information is sought

1. RAIL TRANSPORT LINES

- a. Inter-city lines
    - (1) Major lines
    - (2) Connecting lines
    - (3) Branch lines
    - (4) Other
  - b. Intra-city lines
    - (1) High-capacity lines
    - (2) Other lines
    - (3) Other
  - c. Inter-city lines
    - (1) Lines to which 1 is applied
  - d. Intra-city lines
    - (1) Lines to which 1 is applied
2. MOTOR TRANSPORT ROADS
- a. Main highways
    - (1) Interstate
    - (2) State routes
    - (3) Other routes
    - (4) Other
  - b. Other main roads
  - c. Secondary roads
  - d. Other roads
3. WATER TRANSPORT ROUTES
- a. Oceanic
    - (1) Routes
    - (2) Routes
    - (3) Routes
  - b. Inland waterways
    - (1) Waterways
    - (2) Other

Indicate in which information is sought

1. IDENTITY DATA

- a. Type of transport
- b. Name of line
- c. Location
  - (1) Specific information
  - (2) Other information

2. CHARACTERISTICS DATA

- a. Physical
  - (1) Operating system
  - (2) Capacity
- b. Technical
  - (1) Operating system
  - (2) Operating system
- c. System information
  - (1) Name of line
  - (2) Information on other lines

3. ACTIVITY DATA

- a. Traffic volume
  - (1) Routes
  - (2) Other
- b. Use
  - (1) Freight
  - (2) Other
  - (3) Other
  - (4) Other

4. PROFILE DATA

- a. Railways
  - (1) Lines
  - (2) Lines
  - (3) Lines
- b. Roads
  - (1) Lines to which 1 is applied
- c. Waterways
  - (1) Lines
  - (2) Lines
  - (3) Lines

B - Transport Vehicle Concentrations

Indicate in which information is sought

1. RAIL ROLLING STOCK CONCENTRATIONS

- a. Manufacturing yards
- b. Repair centers
  - (1) Locations
  - (2) Other
- c. Yards
  - (1) Lines to which 1 is applied
- d. Freight yards
- e. Stations
  - (1) Freight
  - (2) Other
- f. Other
- g. Other

2. SHIP CONCENTRATIONS

- a. Dock areas
  - (1) Specific dock areas
  - (2) Other
- b. Other
- c. Harbors and anchorages
  - (1) Other
  - (2) Other
- d. Other

3. MOTOR TRANSPORT CONCENTRATIONS

- a. Trucks
  - (1) Specific
  - (2) Other
  - (3) Other
  - (4) Other
- b. Other heavy prime movers
  - (1) Lines to which 1 is applied
- c. Heavy trailers
  - (1) Lines to which 1 is applied
- d. Other motor vehicle concentrations

Indicate in which information is sought

1. IDENTITY DATA

- a. Type of transport
- b. Type of manufacturing unit
- c. Location
  - (1) Specific
  - (2) Other

2. CHARACTERISTICS DATA

- a. Geographic
  - (1) Any other
  - (2) Other
- b. Transport destination
  - (1) Specific to destination
  - (2) Other
  - (3) Other

3. ACTIVITY DATA

- a. Charge out
  - (1) Other
  - (2) Other
- b. Function
  - (1) Specific information
  - (2) Other

C - Transport Installations

Indicate in which information is sought

1. RAILWAY INSTALLATIONS

- a. Diesel Maintenance Centers
  - (1) Other
  - (2) Other
  - (3) Other
- b. Major Repair Shops
  - (1) Locations
  - (2) Freight car repair shops
  - (3) Other
- c. Fabrication plant assembly
  - (1) Lines to which 1 is applied
- d. Manufacturing yards
  - (1) Freight
  - (2) Other
- e. Freight depots
- f. Freight yards
- g. Freight stations
- h. Switching centers
- i. Other

2. WATER SHIPPING INSTALLATIONS

- a. Dock areas (in systems)
  - (1) Freight
  - (2) Other
- b. Wharves
  - (1) Operating ships
  - (2) Other
- c. Freight depots
- d. Canal locks
- e. Docks
  - (1) Specific information
  - (2) Other
  - (3) Other
- f. Other

3. MOTOR TRANSPORT INSTALLATIONS

- a. Motor transport facilities
  - (1) Other
  - (2) Other
  - (3) Other
- b. Maintenance & Repair centers
- c. Highway routes
  - (1) Lines to which 1 is applied

Indicate in which information is sought

1. IDENTITY DATA

- a. Name of facility
  - (1) Type of transport
  - (2) Type of facility
  - (3) Other
- b. Orientation
  - (1) Specific location
  - (2) Other
  - (3) Other

2. CHARACTERISTICS DATA

- a. Physical
  - (1) Application to destination
  - (2) Specific location
  - (3) Other
- b. Technical
  - (1) Operating capacity
  - (2) Performance statistics
- c. Structural
  - (1) Type of structure
  - (2) Material used
  - (3) Structural details

3. ACTIVITY DATA

- a. Function
  - (1) Function performed
  - (2) Other
- b. Use other
  - (1) Other
  - (2) Other

D - Transport Equipment

Indicate in which information is sought

1. RAILWAY ROLLING STOCK

- a. Equipment
  - (1) Lines
  - (2) Other
  - (3) Other
- b. Freight cars
  - (1) Freight
  - (2) Freight
  - (3) Other freight cars
- c. Rolling stock, other

2. SHIPS

- a. Freight - self-propelled
  - (1) Operating
  - (2) Other
  - (3) Other
  - (4) Other
- b. Freight barges
  - (1) Lines to which 1 is applied
- c. Combined freight & passenger
  - (1) Lines to which 1 is applied
- d. Other shipping

3. MOTOR TRANSPORT

- a. Trucks
  - (1) Other
  - (2) Other
- b. Heavy prime movers
- c. Heavy trailers
- d. Other motor transport vehicles

4. OTHER TRANSPORTATION EQUIPMENT

- a. Cargo handling (hoist)
- b. Locomotive operating equipment
- c. Other equipment

Indicate in which information is sought

1. IDENTITY DATA

- a. Name
- b. Purpose
- c. Use

2. CHARACTERISTICS DATA

- a. Physical
  - (1) Operating & performance
  - (2) Capacity
  - (3) Performance statistics
- b. Technical
  - (1) Information
  - (2) Information
  - (3) Information
- c. Control coding (name plate, etc.)

3. ENVIRONMENT DATA

- a. Specific use
  - (1) Other
  - (2) Other
- b. Basis for classification
  - (1) Specific information
  - (2) Other information
- c. Basis for production
- d. Basis for construction

CONFIDENTIAL

CONFIDENTIAL

CONFIDENTIAL

TABLE II  
GROUP IV - OTHER CATEGORIES

**A - Terrain**

(Material yet to be prepared on this category)

**B - Meteorological**

(Material yet to be prepared on this category)

**C - Hydrographic**

(Material yet to be prepared on this category)

**D - Electronic Emission Facilities**

Subjects to which information is sought:

1. COMBAT VEHICLE & WEAPON GUIDANCE  
(See 2-A-4)
2. MILITARY COMMUNICATIONS
  - a. By Enemy Organizational Assignment
    - (1) Combat Units
    - (2) Functional Force Eqs.
    - (3) Intermediate Eqs.
    - (4) Signal Headquarters
    - (5) Special Combat Units
    - (6) Other
  - b. By Means Employed
    - (1) Radio Communications
    - (2) Other Telecommunications
    - (3) Other signal communications
    - (4) Other
  - c. By Enemy Use
    - (1) Soldier & Casual
    - (2) Command
    - (3) Intelligence
    - (4) Administration
    - (5) Other
  - d. By Our Use
    - (1) Message Content Recording
    - (2) Traffic Location
    - (3) Force Symbols
    - (4) Technical Analysis
    - (5) Communications
    - (6) Other

Factors of the information sought on each of the subjects above:

1. EMISSION DATA
  - a. Existence of emission
  - b. Characteristic of emission
  - c. Location of source
2. MESSAGE CONTENT DATA
  - a. Emission Record
  - b. Message Substance
  - c. Basis for Decoding
  - d. Analysis of Procedure
3. USE DATA
  - a. Activity
    - (1) Periodic Rates
    - (2) Peak Rates
  - b. Basis for Use
    - (1) Performance
    - (2) Employment
  - c. Distribution
    - (1) Basis for Employment
    - (2) Geographic Distribution
    - (3) Unit Assignment
4. NEW TECHNIQUES DATA
  - a. Cypher Techniques
  - b. Control & Guidance Techniques
  - c. Communication Techniques
  - d. Other New Techniques
    - (1) Operational
    - (2) Technical

**E - Other**

(Material yet to be prepared on this category)

CONFIDENTIAL

CONFIDENTIAL

SECRET

SECRET

SECRET

CONFIDENTIAL

CONFIDENTIAL

SECRET

35(d)



~~CONFIDENTIAL~~

TABLE III  
Pre-D-Day Conditions

USE CATEGORIES

PRE-D-DAY  
CONDITIONS

INFORMATION CATEGORIES

	High Level Policy and Programing	War Planning	Force Programing	Research and Development Programing	Determination of Assault Conditions	Final Readiness and Deployment	Area Development (S A O)	Target Development (S A O)	Target Assault (S A O)	AF Deployment Development	Counter AF Target Development	Counter AF Target Assault	Ground Force Deployment Development	Tactical Target and Area Development	Tactical Target Assault	Moving Target Development and Assault	Battle Area Mapping	Relative importance of data for all uses (Σ values x weights / Σ weights)
Importance of End-Use (Weighting Factor)	2	2	3	4	1	5	1	2	0	2	2	0	2	1	0	0	0	
Basic Weapons	20	19	20	20	20	12	4	4		10	18		14	12				15
Basic Force	20	20	20	19	19	12	5	5		10	18		16	17				15
Military Installations	12	15	9	8	9	19	12	6		18	20		20	20				14
Military Materiel	5	7	5	12	5	3	1	1		1	5		4	6				5
End Products Facilities	16	9	11	7	4	1	10	20		1	1		1	1				7
Basic Materials Facilities	11	7	10	9	3	1	9	16		1	1		1	1				6
Basic Utilities Facilities	11	5	8	4	2	1	13	14		1	1		1	1				5
End Products	1	1	2	6	1	1	1	3		1	1		1	1				2
Transport Systems (Nets)	7	12	10	8	10	9	20	8		14	8		14	8				10
Transport Vehicle Concentrations	1	3	2	1	1	19	3	4		3	4		17	10				7
Transport Installations	4	8	7	3	8	17	18	7		9	6		6	6				7
Transport Equipment	1	1	1	4	1	3	5	2		1	2		3	5				2
Map (Terrain)	4	10	10	14	12	1	6	9		12	16		15	10				9
Meteorological	5	11	11	16	12	5	4	10		13	12		8	7				10
Hydrographic	7	5	5	4	1	1	1	1		1	1		3	1				3
Electronic Emissions Facilities	9	8	7	18	17	20	16	4		20	16		18	4				14

~~CONFIDENTIAL~~

~~CONFIDENTIAL~~

TABLE IV

Post-D-Day Conditions

INFORMATION CATEGORIES	USE CATEGORIES																
	High Level Policy and Programming War Planning	Force Programming	Research and Development Programming	Determination of Assault Conditions	Final Readiness and Deployment	Area Development (SAO)	Target Development (SAO)	Target Assault (SAO)	AF Deployment Development	Counter AF Target Development	Counter AF Target Assault	Ground Force Deployment Development	Tactical Target and Area Development	Tactical Target Assault	Moving Target Development and Assault	Battle Area Mapping	Relative importance of data for all uses (Σ values x weights/Σ weights)
Importance of End-Use (Weighting Factor)	1	2	0	0	2	3	2	5	4	3	4	3	2	1	1		
Basic Weapons	20	20			10	7	7	10	5	5	10	5	5	8	8	9	
Basic Force	20	15			5	8	9	10	20	10	10	20	10	20	10	12	
Military Installations	10	6			7	5	1	15	20	15	15	20	15	14	9	13	
Military Materiel	2	1			1	1	4	2	5	5	5	5	5	10	2	4	
End Products Facilities	13	1			17	20	9	9	5	1	1	1	1	1	1	6	
Basic Materials Facilities	10	1			16	18	8	7	3	1	1	1	1	1	1	5	
Basic Utilities Facilities	7	1			18	19	7	3	1	1	1	1	1	1	1	5	
End Products	1	5			1	1	1	1	1	1	1	1	1	1	1	1	
Transport Systems (Nets)	15	5			20	15	11	5	4	14	10	5	13	12	16	10	
Transport Vehicle Concentrations	4	1			6	7	8	2	2	5	16	20	9	10	7	8	
Transport Installations	6	1			12	16	5	2	4	10	8	5	6	7	6	7	
Transport Equipment	1	3			2	4	1	1	2	1	6	8	11	8	2	4	
Map (Terrain)	3	12			18	13	10	10	10	16	15	8	20	15	20	13	
Meteorological	3	16			7	9	18	10	13	20	10	12	20	10	15	13	
Hydrographic	1	5			8	2	1	3	1	1	4	1	2	1	5	3	
Electronic Emissions Facilities	8	14			18	14	20	20	12	18	20	15	10	5	3	15	

~~CONFIDENTIAL~~

~~SECRET~~

~~CONFIDENTIAL~~

TABLE V

A CHECK LIST OF BASIC SENSING TECHNIQUES

A - Direct Sensing Media

1. PHYSICAL POSSESSION
2. DIRECT VISUAL OBSERVATION
  - a. Our air crews
  - b. Other official observers
  - c. Unofficial observers
  - d. Other visual observers
3. REFLECTION OF NATURE-PRODUCED WAVES
  - a. Natural Light Reflection  
(Daylight photography)
  - b. Cosmic Ray Reflection
  - c. Other Wave Reflection
4. REFLECTION OF MAN-PRODUCED WAVES
  - a. Electronic Reflection
  - b. Light Reflection  
(Night photography)
  - c. Heat Reflection
  - d. Other Wave Reflection
5. DISTORTION OF NATURAL FORCES
  - a. Magnetic Distortion
  - b. Gravity Distortion
  - c. Other Force Distortion
6. EMISSION DETECTION AND ANALYSIS
  - a. Telecommunication Emission
  - b. Heat Emission
  - c. Electric Power Emission  
(Induction)
  - d. Noise Emission
  - e. Light Emission
  - f. Chemical Emission      Air and Water
  - g. Radioactive Emission      Sampling
  - h. Other Emissions

B - Indirect Sensing Media

7. PERSONAL KNOWLEDGE DETECTION AND ANALYSIS  
(Individual Interrogation Technique)
  - a. Friendly Travellers
  - b. Emigrees
  - c. Agents and Resident Defectors
  - d. Non-resident Defectors
  - e. Residents
  - f. Others having, or having access to, special knowledge
8. TELECOMMUNICATION MESSAGE CONTENT ANALYSIS
  - a. "Clear" Message Analysis
  - b. Cryptographic Analysis
  - c. Other Message Content Analysis
9. TECHNICAL LITERATURE CONTENT ANALYSIS
10. OFFICIAL DOCUMENT CONTENT ANALYSIS

~~CONFIDENTIAL~~

~~SECRET~~

~~CONFIDENTIAL~~

CHAPTER 4

SURVEILLANCE OF RADIO AND RADAR EMISSIONS

~~CONFIDENTIAL~~

~~SECRET~~

~~CONFIDENTIAL~~

CHAPTER 4  
SURVEILLANCE OF RADIO AND RADAR EMISSIONS

NOTE: Radio and radar intercept are jointly discussed in this Chapter because the proper exploitation of both in Air Force reconnaissance operations can provide important information on enemy strength and deployment. Because of special clearance requirements, the BEACON HILL Study Group was not briefed on Air Force activities in communications intercept, and on only those aspects of electronic warfare generally that are not limited by classifications beyond TOP SECRET. The group was assured that its suggestions would be welcomed in all fields, but it must be understood that in radio intercept they were formulated without knowledge of current operations.

A. INTRODUCTION

This Chapter is concerned with the technical means for exploiting one of the sources of intelligence provided by enemy radio and radar transmitters. We shall discuss here an aspect of electromagnetic surveillance distinct from the specialized ferret operations now carried on by the Air Force. Where ferret intercept seeks to determine the information content and the type of equipment used - in short, to analyze the emissions - we propose methods for search and broad-band interception.

A military force uses radio for communications; it uses radar for air defense; it may use radio emissions of various sorts for special purposes such as navigation or missile guidance. Any such activity, if we are able to detect it, is a direct, immediate disclosure of an up-to-date fact about military force and its deployment. As pointed out in Chapter 2, it is precisely this kind of information that is most crucial, and in shortest supply.

We believe the radio communication activity of enemy units is the most important electromagnetic source of information needed to put together a picture of the immediate strength, deployment and intentions of the opposing military force. This is true even if we exclude message content. Obviously, message interception and analysis, considered as distinct from the detection of a radio transmission, can yield valuable intelligence of the classical variety, but that is not the subject of discussion here. In the past, it has not been so obvious that the bare fact that a transmitter at a certain place was on the air on a certain frequency at a certain time is a piece of information that can be assembled, with hundreds of similar pieces, into a revealing pattern.

We are faced here with a curious anomaly; a single piece of information to the effect that a single transmitter emitted a given signal at a given time and place means nothing in isolation; but a set of properly collated bits of information regarding n transmitters emitting n signals may neatly disclose what the enemy is doing. Military forces cannot operate without talking, and orderly communications require an orderly assignment of transmission frequencies to military units. The continuous surveillance of the use of these frequencies and of the day-to-day changes in the pattern and location of transmissions will provide a large measure of our required information on the enemy's force and deployment.

In much the same way, the detection of radar transmissions contributes to

~~CONFIDENTIAL~~

~~SECRET~~

~~CONFIDENTIAL~~

the estimate of enemy strength and deployment. Here again, for assembling a picture of force disposition, for discovering unsuspected concentrations of air defense, for estimating the enemy's investment in basic radar equipment and the like, an elaborate and precise analysis of each radar signal is not needed and is not, in fact, desirable. We want many independent pieces of information, each of limited content. Although this seems to us perhaps the most important, and certainly the most neglected, aspect of radar interception, it is not the only one. There is also the very important and specific task of analyzing in detail the radar defenses of a particular target against which an operation is planned. This task needs to be done before the attack, in order to plan the attack and prepare suitable countermeasures; and it needs to be done during the attack in order to use the countermeasures effectively. All this is the electronic countermeasure (ECM) function of radar interception. Finally, radar interception, indeed radio-wave interception in general, is a way of guarding against technological surprise. We need only recall the antisubmarine campaign of 1942 and 1943, in which we were able to contain the threat solely because the German submarine force was unaware that microwaves were being used against it - a fact that could have been discovered by the most rudimentary and primitive receiver.

Continuous and comprehensive surveillance of radio and radar emissions offers the most promising new means of securing basic Soviet force data. Observation of the pattern of radio and radar activity will reveal enemy strength, enemy deployment, and enemy intentions.

To make the following discussion clear, and to define our point of view, it will help to delimit rather distinctly the three functions of radio and radar surveillance we have just described:

- Function A: - Collection of data revealing force strength and disposition (radio communication and radar transmissions);
- Function B: - Analysis of radar target defenses for countermeasure purposes (radar intercept, mainly).
- Function C: - Detection of new types of electromagnetic activity, such as the use of entirely new wavelengths (surveillance of the entire spectrum, including those parts we have not ourselves exploited).

Collection, analysis, and detection are the key words here; each emphasizes the main purpose of the respective activity. We are aware of several special functions that do not fit neatly under any one of the above definitions, but these should not be allowed to confuse the issue.

All three of these functions can and must be exercised both pre- and post-D-Day. In fact, during the period before it is possible to penetrate enemy territory, radio and radar surveillance will prove a rewarding technique, even though they are limited to border areas. As soon as penetration is in order, the full force of the technique can be brought to bear. Since the various features of the surveillance problem are most clearly revealed in the design of a post-D-Day capability, we shall first consider this aspect of the issue in the following discussion. Thereafter, we shall examine some of the ways in which surveillance

~~CONFIDENTIAL~~

~~SECRET~~

~~SECRET~~  
~~CONFIDENTIAL~~

procedures might be adapted to the pre-penetration phase.

#### B. PRESENT CAPABILITY

The equipment in the Air Force's ECM program is the embodiment of a more specialized conception of radar surveillance than that outlined above. It is not hard to understand how this has come about. One reason, a natural and valid one, has been the emphasis on the strategic bombing mission, in which the radar-counter-radar battle is of crucial importance. Another reason, more or less historical, has been the preoccupation, in the ECM field, with superheterodyne receivers of high sensitivity, narrow band, and ever-increasing complexity. Still a third reason has been the tendency to overlook the significance of random emissions in favor of the precise analysis of signals; thus we find the intercept probability of a receiver sacrificed in order to permit a precise frequency measurement for which no real need exists in many important applications. For these reasons, and possibly others, we are left at present with equipment capable of measuring very precisely the characteristics of a signal once it is received, but having only a very slight probability of detecting any single random signal. This equipment requires a large airplane to carry it, specialists to operate it and to interpret the data, and has no capability of gathering a statistically significant quantity of information of the type required for Function A. This equipment makes sense only in terms of Function B, and even for that purpose we suspect a better compromise might be struck between complexity and capability. Function C is one, among others, that the ferret equipment is intended to perform; it is inadequate to perform it. How inadequate can be indicated by pointing out this fact: not until five years from now, according to present plan, will the Air Force possess any receiver whatever capable of detecting radiation of frequency higher than 10,750 Mc. In other words, if the enemy should have fire-control radar operating on the 2.5-cm wavelength - a good wavelength for the purpose, incidentally, the development of which would require only a slight scale-down of 3.2-cm components - we would have no way of detecting its use against us. We would be precisely in the position of the German U-boats in 1943 - this despite the fact that a simple receiver capable of detecting such radiation could have been constructed in 1945 from standard components. We feel that the lack of a receiver for the region above 10,000 Mc is a serious gap that must and can be plugged. We strongly urge that a few wide-band crystal receivers be built at once - by hand, if necessary.

As for the radio intercept part of Function A, we do not know of any equipment planned for that special purpose and able to collect, as a routine operation, data in the quantity required. An operator with a conventional radio receiver, or even a panoramic receiver, does not fill the bill. What is needed is an unattended receiver that will cover a wide band and automatically log signal frequency, signal direction, and immediate flight data. It may be objected at this point that what we have just described has been the goal of intercept receiver development all along, and that the ideal has not been attained only because the technical problems involved are so formidable. We believe, on the contrary, that there has been too much emphasis on signal analysis, and too little emphasis on signal detection and the estimation of radio communications activity.

~~CONFIDENTIAL~~

~~SECRET~~

~~CONFIDENTIAL~~

~~CONFIDENTIAL~~

### C. SURVEILLANCE OF RADIO EMISSIONS

We shall describe one approach to the problem of how surveillance of radio activity might be done, not with the idea that it is the best or only way to solve the technical problem, but rather to define the problem by giving a concrete example of a possible solution. The example may also help to suggest how a reasonable compromise can be reached between the demand for complete information and the need for reliable, adaptable equipment.

We want to be able to fly over enemy territory and return with an easily interpreted record showing the location and frequency of enemy transmitters active during the period, and the times and duration of their transmissions. That is the ideal. We recognize at the outset that the transmissions of greatest interest will not be long-distance command communications, but rather the short-range communication activity of local units, ground-to-air communications at an airfield, and the like.

Soviet ground-to-air and air-to-air communications are believed to employ mainly (perhaps exclusively) frequencies from 2.5 to 12 Mc,\* with a normal channel spacing of 25 kc. Little seems to be known about the application of higher frequencies to air communication, but, according to the report cited, there are established three other systems of channel assignment, namely: "System Two," 2.5 to 14 Mc, 101 channels of 115 kc width; "System Three," 25 to 40 Mc, 126 channels of 125 kc width; "System Four," 40 to 60 Mc, 41 channels of 500 kc width. No information on U.S.S.R. ground-force frequency assignment has been available to us, but the above is perhaps a valid, if rough, indication of the territory we have to cover in routine surveillance. Of course, we must keep alert to the use of still higher frequencies. On the whole, the picture with fewer and broader channels is less diverse than that of our own military radio communications. This simplifies some of the technical problems of surveillance.

Let us consider the 2.5 to 12 Mc band as an example. To simplify certain radio-frequency (RF) problems it might be well to divide the band roughly into two parts. Let us take the band from 6 to 12 Mc, and treat it as follows. Two separate antennas are connected directly to two converters fed from a common local oscillator. The output of the local oscillator is amplified at a fixed intermediate frequency (IF) in a separate amplifier with a pass band of about 25 kc (see Fig. 4-1). By sweeping the local oscillator only, we can thus scan the 6-Mc band and discriminate frequencies with an accuracy comparable to the channel spacing. Actually, we are not interested in knowing the frequency of a given transmitter to this accuracy, for we are not so much concerned with finger-printing the individual as with measuring the activity of the population. We need to sort the channels merely to reduce the probability of being confused by simultaneous transmissions from two or more sources. Experience and accumulated intelligence may show that an even coarser division is acceptable.

The output of the IF amplifiers, with the modulation removed, is fed in to a phase comparator. Since the relative phase of the IF signals is the same as that of the RF signals at the two antennas, this measurement of relative phase provides an interpretable bearing determination. The result of the bearing determination is immediately printed on a tape,

\*ATIC Report 102 EL 19/51-34.

~~CONFIDENTIAL~~



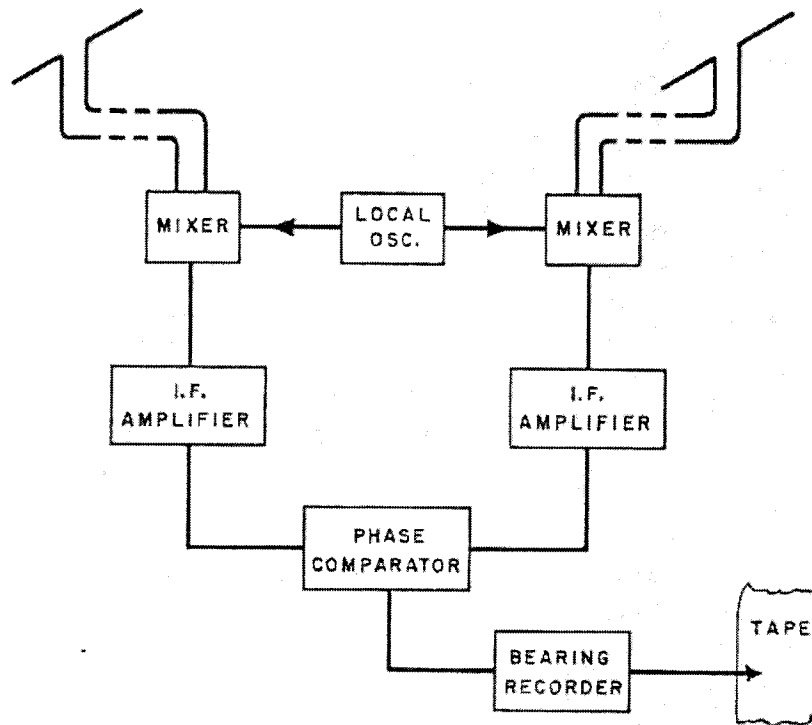

Fig. 4-1. Schematic diagram of system for surveillance of radio emissions.

~~CONFIDENTIAL~~

together with a record of the frequency to which the local oscillator was tuned at that instant, and the position and heading of the aircraft. With a bandwidth of 25 kc, it should be possible to complete the phase comparison, to the accuracy required, in no more than one to two milliseconds, and hence it should be possible to scan the 6-Mc band in about one second. Any transmission of duration longer than one second could thus be caught in the net and tabulated. If the same transmitter is heard some time later, when the plane is in a different position, the tabulated record will contain information from which two different lines of bearing, and hence a fix, can be deduced.

The two antennas should be separated by a distance comparable to, but somewhat less than, a quarter-wavelength of the highest frequency. This appears feasible for the band under discussion and for any higher-frequency band. It may be somewhat of a squeeze below 6 Mc, but, by making the phase comparison more accurate there (at the expense of a somewhat slower scan), a bearing determination ought still to be possible.

Confusion or ambiguity of interpretation can readily arise in this simple system if two transmitters operate on indistinguishable frequencies; also, phase comparison between two omnidirectional antennas generates two lines of bearing, an ambiguity that can be avoided by a slightly more elaborate scheme. Simultaneous phase comparison among three antennas, for example, would suffice. Even with these limitations, a typical record should contain enough possibilities for cross-checking to enable a great deal of reliable and unambiguous information to be extracted from it.

Obviously, this sketchy outline of a system leaves untouched many difficult technical problems.\* The antenna installation is not an easy problem, and the method of recording the information at the output of the phase comparator, identifying the frequency channel on the record, etc., needs careful study. These do not appear to be insoluble problems.

The radio receiver just described is not a good radio receiver by the usual standards. It is not very selective and, even worse, it does not have image rejection. But it is a better receiver for the intended purpose than any conventional superheterodyne receiver however refined. Widening the band has shortened the scanning cycle so that the intercept probability is high, without throwing away useful information. The sacrifice of image rejection has eliminated tracking RF amplifiers, which would not only complicate each receiver but would make it extremely difficult to preserve relative phase for eventual comparison at the intermediate frequency. The appearance of the image on the record will, of course, increase somewhat the probability of confusion; this disadvantage is partly offset by the corroborative function of the image, but in any case the disadvantage is unimportant in comparison with the simplicity and flexibility thus purchased.

---

\*One possible use of radio intercept that has not been considered in our study is exploitation of enemy electromagnetic (EM) emissions as navigation aids by our own bombing missions. This is the reverse of the situation discussed in Chapter VI of the PROJECT CHARLES Report (Vol. I), where plans to deprive the U.S.S.R. of navigation by means of our radiations were discussed.

Thorough study of the possibility of our navigating by this means might prove the method unfeasible or of no value, but it might serve a good purpose by allowing the enemy to believe that we are prepared to navigate by his radio transmitters.

~~CONFIDENTIAL~~

~~CONFIDENTIAL~~

**CONFIDENTIAL**

The description above may serve to show the general direction that, in our opinion, might profitably be taken in the development of a radio intercept system aimed at performing Function A. It is a major undertaking, and one that will succeed only if guided at every stage by a careful weighing of intelligence requirements against technical possibilities.

The continuous surveillance of enemy use of a wide range of radio frequencies and of the day-to-day changes in the pattern and location of the transmissions can be achieved by equipment specially designed for this purpose.

#### D. SURVEILLANCE OF RADAR EMISSIONS

We shall concern ourselves here with Functions A and C only, that is, with radar surveillance not tied directly to countermeasures. What is called ECM falls mainly in our category labeled Function B; it has received the chief attention in the past, and partly for that reason and partly for lack of time, we have given it rather scanty attention.

The first point to be made in any discussion of radar intercept is the heavy advantage the interceptor enjoys by being at the end of a one-way, rather than a two-way, path. Receiver sensitivity is almost the least of the designer's problems. The second point to keep in mind is that most radar antennas scan. To intercept with high probability, one must, therefore, have the receiver sensitive to all likely frequencies most of the time, in order not to be looking for the radar signal when it is being directed somewhere else.\* A third observation, pertinent especially to the ultra-high-frequency and microwave part of the spectrum, is that a narrow-band receiver capable of scanning a fractionally large frequency band is inherently a fairly tricky device, and the difficulties increase with the frequency.

Fortunately, there exists a technique, crystal video reception, that is very well adapted to the peculiar requirements of radar surveillance. The technique is well known and extremely simple. It lends itself to the construction of very-wide-band continuously sensitive receivers at all frequencies from 50,000 Mc down.

An early example of the technique was the "Auto Search" intercept receiver, APR-1, developed during World War II for reception in the range 90 to 1000 Mc, with automatic recording of frequency and time. During the same period, crystal video receivers were also developed, mainly for radar-beacon reception, at still higher frequencies. Microwave receivers were made on a production basis (UPN-4, for example) which had a sensitivity of  $10^{-8}$  watts, quite adequate for radar surveillance in most circumstances. The application of this technique to radar intercept has come about slowly, but at least some work in this direction is now under way, under both Navy and Air Force sponsorship. We believe, however, that the capability of the crystal receiver is still not recognized widely enough. In the tabular

---

\*From these two observations, the opposite conclusion can be and has been drawn, namely, let us make a receiver so sensitive that it can detect the radar by its back lobes even when the radar antenna is pointed another way, and then we need not worry about the scanning cycle. Some such philosophy seems to have guided most of the post-war development of intercept receivers in this country. It may have its place in certain special situations but, in view of the complexity and inadequacy of the receivers to which it has led, we cannot accept it as a guiding doctrine.

~~CONFIDENTIAL~~

**CONFIDENTIAL**

~~SECRET~~

**CONFIDENTIAL**

presentation of the ECM program given to us in our briefings, we find "wide-band crystal receivers" relegated chronologically to the column headed "Future," which lies on the far side of a column headed "In Five Years." considering that the basic technique was fairly well worked out in 1945, one must conclude that this classification reflects a belief that crystal receivers are not much good for radar intercept. It is our belief, and we find it shared by others closer to the subject, that the crystal receiver offers a practical solution to many of the technical problems of radar surveillance, especially where detection rather than analysis is the important function. We, therefore, recommend that this technique be vigorously developed and exploited.

There is little doubt that the basic technique can be improved. There is evidence that a good converter crystal is not a good detector, which suggests that the crystal, as a detector, is still susceptible to improvement. It is our understanding that the crystals now being used as detectors are those originally developed for converter use, and that full advantage has not yet been taken of the work that has been done on detector crystals as such. Apart from the crystal itself, there is a great opportunity here for the ingenious use of multichannel RF circuits and simplified video amplifiers, looking eventually toward surveillance receivers that work more like an ear and less like a conventional radio set. It is the great virtue of the crystal receiver that the specialized RF circuits end at the input to the amplifier; everything beyond can be a standard unit. Moreover, if we look ahead to the use of transistors, every tube in a crystal video receiver is replaceable by a transistor; this would make multiplication of channels possible on a scale far beyond anything that could be accomplished with receivers dependent on RF oscillators or amplifiers. It is in this general direction, we believe, that development of radar intercept techniques should be concentrated.

The application of crystal video techniques offers a promising means to exploit the potentialities of surveillance of radar transmissions.

Turning from the basic techniques to the systems, we are impressed with the need for, and the lack of, airborne intercept equipment capable of collecting and recording the elementary information needed for Function A. What are the elements of this information? Every active radar within range of the reconnaissance vehicle should generate automatically a record of:

- (1) The detection of a pulsed signal and the position of the reconnaissance vehicle at the time of detection;
- (2) The approximate frequency of the signal (within 10 or 20 per cent, for identification of the class of equipment involved);
- (3) Approximate true bearing of transmitter;
- (4) Pulse-repetition rate;
- (5) Scanning cycle.

These items are by no means of equal importance. Certainly (1) is the most important bit of information; with (2) and (3) added, we have perhaps 90 per cent of the useful information. Items (4) and (5) are really luxuries, and are listed only because they come fairly easily, and

**CONFIDENTIAL**

~~SECRET~~  
~~CONFIDENTIAL~~

are of some help in identifying the type of equipment. We could lengthen the list by other luxury items, such as:

- (6) Signal strength;
- (7) Pulse envelope;
- (8) Precise frequency;
- (9) Polarization.

Adding these requirements increases the usefulness of the information only slightly, complicates the data-handling problem, and severely complicates the airborne equipment. The point is that it is far better to be able to collect data (1), (2) and (3) only, for all active radars within range, and with equipment that does not require a B-36 to carry it, than to determine (1) through (9) for a few examples by means of a flying laboratory.

Of the important items, probably (3) poses the most difficult technical problem. It may even turn out that, by omitting this requirement for direction finding - or weakening it to call for a mere right-or-left indication - the amount of useful intelligence obtainable with a given total effort would be increased. This is hard to predict, and certainly one ought to try very hard to develop a simple method for instantaneous bearing determination. One very promising approach to the problem has already been made in the APD-4 development.

We have put signal strength in the "luxury" category because, in practice, a reliable measure of this quantity is usually hard to get. This is an arguable point, and one that might be wholly invalidated by some clever invention. The interpretation of a signal-strength measurement is not simple either, but under some circumstances a rough estimate of range to the transmitter might be possible.

The best illustration of the approach we are here advocating is, happily, a development already under way at Federal Telecommunications Laboratories, sponsored by WADC - the development leading toward the APD-4 system. This system is simple in the right places and clever in the right places. It seems to us to represent an imaginative approach to radar intercept as an intelligence problem, not merely as a set of receiver specifications. Whether it represents the best compromise between all the conflicting requirements is hard to tell at this point, but it seems to us a big step in the right direction.

Our own efforts to explore technical possibilities by trying to invent a system led to the scheme illustrated in Fig. 4-2, which we include here only as an illustration of the sort of information that can be obtained by very simple means if the inherent nature of pulsed radar transmissions is used to advantage. This system does not give bearing, but it does give approximate frequency, repetition rate, and scan period, and, if it is receiving signals from several radar transmitters at the same time in the same channel, that fact can be ascertained from the record. One or more omnidirectional antennas are connected through a plurality of RF filters to crystal detectors. Each filter defines a fairly broad channel and each channel has its own video amplifier, timing and counting circuits. Each channel is continuously sensitive to pulses in its band, except for short periods after signals have been received. When a pulse is received, it is counted "1" and a 5000- $\mu$ sec gate is started; all following pulses within this gate are counted, up to a maximum of 15; the receiver is then blanked for one second while the result of the count is recorded as a binary number on Teledeltos paper by simply discharging the

~~CONFIDENTIAL~~

~~SECRET~~

~~SECRET~~

~~CONFIDENTIAL~~

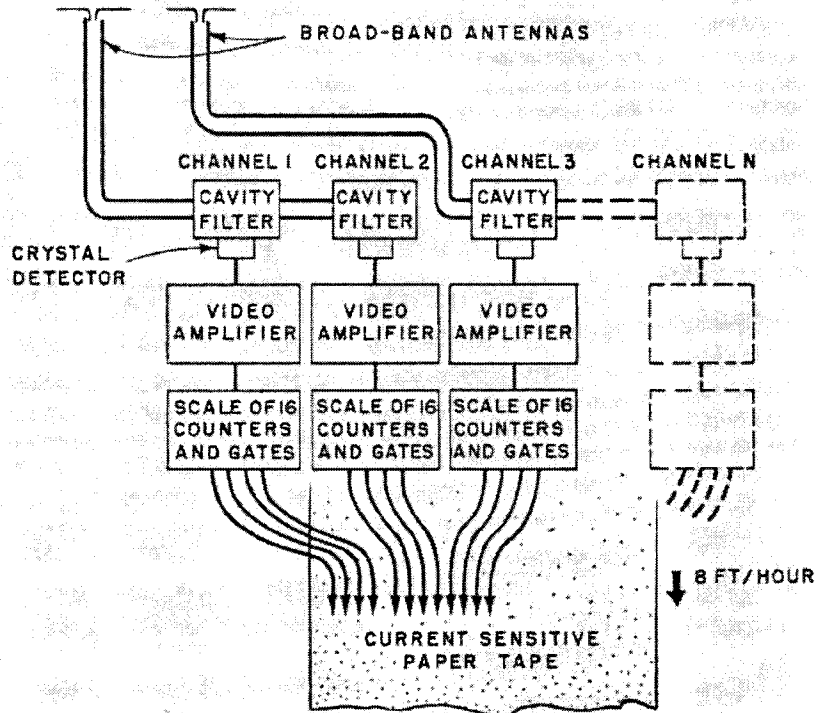

Fig. 4-2. Schematic diagram of possible system for surveillance of radar emissions.

~~CONFIDENTIAL~~

~~SECRET~~

~~SECRET~~  
~~CONFIDENTIAL~~

scaling tubes from their final configuration. The one-second blanking period is shorter than the scanning period of most radar antennas, but long enough to ensure adequate separation between adjacent numbers on the record. At the end of the one-second blank, the receiver and counter are ready to handle the next incoming signal, whenever it may arrive. From the record on the tape the following information is directly available:

- (1) Reception of pulsed signals in a certain frequency band, at time and place to be recorded on tape from flight data.
- (2) Whether the radar was scanning or continuously trained on the receiver.
- (3) If scanning, what the scanning rate was.
- (4) Approximate pulse-repetition rate, or approximate number of radars operating simultaneously in the band, once repetition rates are identified.

The sample records shown in Fig. 4-3 indicate the way in which these characteristics are revealed.

This scheme has very obvious limitations - as any tolerably simple scheme must have - but it has certain instructive advantages. It involves a sequence of simple functions performed by standard low-frequency circuits. The signal analysis, such as it is, is carried out by the most natural and reliable form of automatic measurement - namely, counting; the only point at which the system requires calibration is at a preset intensity discriminator ahead of the counter. The record is in digital form and contains no superfluous information. The system is flexible: the blanking time, channel width, number of channels, can be changed as experience dictates without altering the basic units of the system. We do not urge on anyone this particular scheme. We do assert that a sensible solution to the problem is most likely to be found somewhere in this general direction.

In all this discussion of radar surveillance, we have been thinking mainly of pulse radar. We have to reckon with the possible use of continuous-wave (CW) radar of some variety, and this presents somewhat different problems. With certain modifications, the crystal video receiver may be useful here, also, for achieving continuous sensitivity over a wide band. The use of locally imposed RF modulation, or "chopping" at a frequency high enough to avoid excess crystal noise, appears to be one promising approach. The recently developed "gyrators"\* may provide the means for such modulation. A rough calculation indicates that, if excess crystal noise can be avoided, a sensitivity on the order of  $10^{-11}$  watts may be attainable with an averaging time of one second. This would make the CW sensitivity and the pulse sensitivity roughly equal on an average-power basis.

The full realization of the possibilities of radar surveillance  
requires the development of airborne equipment capable of  
automatically recording the information collected.

\*C. L. Hogan, Bell System Technical Journal, January, 1952.

~~CONFIDENTIAL~~

~~SECRET~~

E. SURVEILLANCE FROM OUTSIDE: AIRBORNE REPEATERS

The interception of radio and radar emissions by means of vehicles that pass over enemy territory involves enough risks to place a premium on means that operate entirely over friendly territory or areas controlled by us.

Suppose we consider a receiver at altitude and ask what will be received. A simplified picture of the propagation problem is shown in Fig. 4-4. In the area marked "primary coverage", it is possible to receive the transmitted waves a very high percentage of the time. The distance D at which this can be done varies as the factor  $\sqrt{h}$ , where h is the altitude of the receiver. Typical numbers are:

D (miles)	h (feet)
420	100,000
140	10,000

A signal will be received at these distances at all frequencies - broadcast, communication, radar, microwave, etc. - assuming only that there is a certain minimum transmitted power. This minimum is very likely to be available; for example, a standard U.S. broadcast station should produce a readable signal at a distance of 800 miles in the primary area.

At distances D where the receiver altitude is too small to reach the primary area (beyond 420 miles at 100,000-foot altitude), a signal will be received at certain frequencies part of the time. The communication-band frequencies are very likely to go considerably beyond the distances given above, and the very-high-power transmitters (such as radars) may also produce readable signals at much greater distances. The propagation effects to be expected are not definitely known for these unusual conditions. Partially reflecting layers appear at altitudes greater than 150,000 feet. The general situation is promising, however.

The interception could best be done by putting a repeater on a vehicle that can stay at high altitudes for long periods. The repeater is merely a broad-band receiver and a single transmitter, operating at a very high frequency, modulated by all incoming signals within the desired lower-frequency band. The received waves would be rebroadcast to a ground station for analysis and recording.

Very-broad-band repeaters can be built with existing techniques. A very simple repeater with a bandwidth of 10 Mc is a possibility, and such a repeater would relay all the signals in the band from 2 to 12 Mc, for example, or from 20 to 30 Mc, to the ground station simultaneously. This means that a whole battery of receivers and operators at the ground station could examine the band simultaneously, and record whatever seemed to be interesting. The 10-Mc bandwidth could be extended to bands on the order of 200 Mc at the cost of a modest effort. Most of the complicated gear involved in electromagnetic surveillance is included within the recording apparatus and in the selective apparatus required to examine one channel at a time. It appears most sensible to put this recording equipment on the ground. The equipment required in the vehicle can then be reduced to an absolute minimum and can be carried to the maximum possible altitude for the purpose of extending the range of interception.

Several of the vehicles discussed in Chapter 11 might be suitable for this application.

- (1) The X-1 and X-2 airplanes are expected to go to altitudes of 110,000 and



~~SECRET~~  
~~CONFIDENTIAL~~

SAMPLE RECORDS

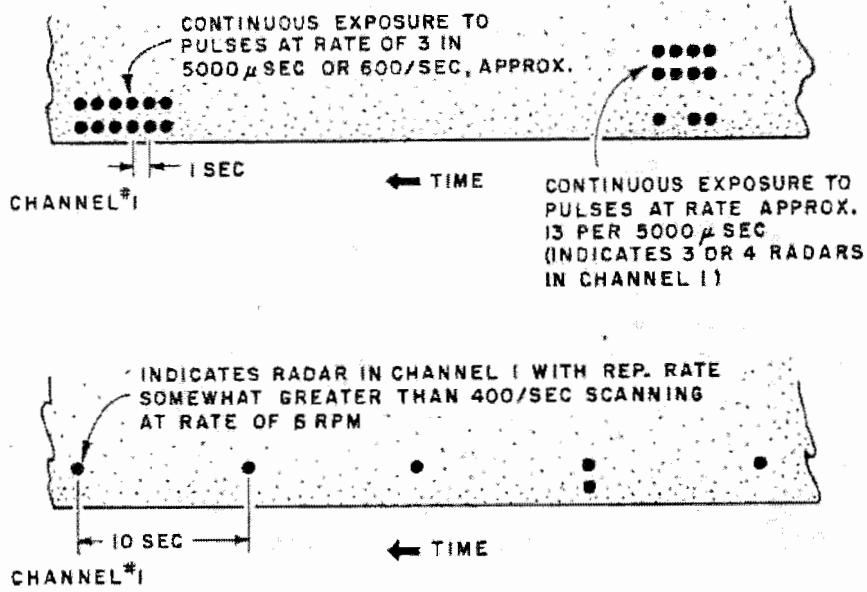

Fig. 4-3. Sample records of typical characteristics obtained from system illustrated in Fig. 4-2.

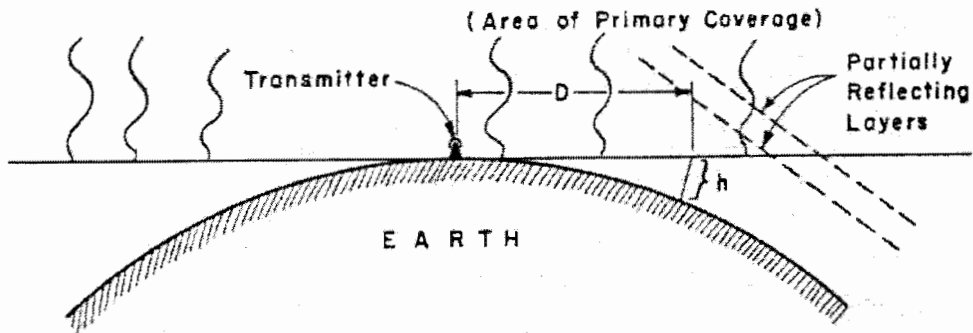

Fig. 4-4. Simplified representation of anomalous propagation problem.

55  
~~CONFIDENTIAL~~

~~SECRET~~

~~CONFIDENTIAL~~

230,000 feet, respectively. They are rocket-propelled, however, and would stay at such altitudes for only very brief periods.

(2) Existing propeller or jet-driven aircraft could be taken to altitudes of at least 40,000 feet and kept there for periods of the order of 10 hours.

(3) If a lighter-than-air vehicle were to be employed, it probably would be impractical to try to maintain it over a fixed location on the ground. Such a vehicle might be allowed to run free, however, and, on the average, be within approximately 50 miles from a fixed ground station for a period of about 2 hours.

A B-36, for example, could probably be taken to an altitude of 40,000 feet and kept there for the 10-hour period indicated. Fighter aircraft could probably be kept at such altitudes for a period of a few hours.

The 40,000-foot altitude would give a line-of-sight range of over 250 miles, meaning that transmitted waves could be intercepted with virtually 100 per cent certainty for such a distance. In addition, the stronger signals would be heard for greater distances.

This approach has the advantage of being directly applicable on a pre-D-Day basis without international complications, and has the post-D-Day advantage of being able to operate in one's own territory and to still obtain the desired information.

Although some new equipments will be required to carry out electromagnetic-wave interception in this manner, the key point is the operational procedure of using the ground-based location for the majority of the equipment.

It is recommended that feasibility studies be made on the use of airborne repeaters to extend the detection ranges of border ground stations for radio and radar surveillance of radio and radar emissions.

#### F. SURVEILLANCE FROM OUTSIDE: USE OF ANOMALOUS PROPAGATION

Without violating Soviet airspace, the methods for radio and radar surveillance discussed so far are limited to ranges of 250 to 300 miles beyond the border. It would obviously be useful if we could, without making any unfriendly intrusion, hear what was going on much deeper in the U.S.S.R. Even if it could be done only occasionally, the intelligence obtained might be very valuable. It is suggested here that the anomalous propagation effects known to occur at times in the very-high-frequency (VHF) and microwave spectrum may make this possible.

Microwaves are sometimes bent around the horizon by a "trapping" phenomenon that occurs in the lower atmosphere. The determining factors are usually the water-vapor gradient and temperature gradient in the lowest several hundred feet of atmosphere. The "anomalous" behavior is not reliable, but in some parts of the world it occurs now and then. Radar ranges of several hundred miles have been recorded under such conditions. How far a radar can be heard is not well known; certainly it should be somewhat farther. Abnormally long ranges are also observed in the ultra-high- and very-high-frequency bands for somewhat different causes.

For the purpose of gathering intelligence, we can afford to wait for an

~~CONFIDENTIAL~~

occasional freak of propagation, if we are equipped to take full advantage of it when it occurs. A permanent listening post on the ground in northern Turkey, for example, might occasionally pick up microwave signals from most of the Ukraine. If it were properly equipped to record and analyze the signals, one might collect in one day's operation during a propagation anomaly a very large amount of information.

The equipment needed for such a listening post already exists, for the most part. The present ferret equipment is well suited to the purpose, except for its antennas. Such a listening post should be equipped with large, high-gain trainable antennas, to increase both the range and the precision of bearing determination. Since this would be a permanent ground installation, there should be no difficulty in this respect. One could also afford considerable elaboration of receiving equipment, far more than could be reasonably effective in an airplane, and it is practical to maintain a continuous watch with operators of very specialized training. This function might well be performed by the specialized units recommended in Chapter 12.

We understand that the British have attempted some work in this field; as a first step, their experience can be studied.

Anomalous propagation effects offer a means of obtaining valuable, if occasional, information. We recommend study of this phenomenon at all frequencies, including UHF, for intelligence purposes.

~~SECRET~~  
~~CONFIDENTIAL~~

## PHOTOGRAPHIC RECONNAISSANCE

Chapter 5 Photographic Reconnaissance with Standard Equipment

Chapter 6 Photographic Reconnaissance with Specialized Equipment

Chapter 7 A New Approach to Photographic Reconnaissance

Aerial photography is the classical sensing technique used by the Air Force for the collection of intelligence data. It is an extremely powerful technique, which has been intensively developed into a whole range of established reconnaissance procedures.

The BEACON HILL Study Group has divided its review of photographic reconnaissance problems into three chapters. In Chapter 5, we consider present and future equipment and techniques suitable for use by normal reconnaissance units. In Chapter 6, we deal with equipment of a more advanced and highly specialized type which, in our opinion, should be used only for special missions by much smaller units of highly trained personnel. This idea of specialized reconnaissance units is further developed in a separate part of our report (Chapter 12), since we believe it to be applicable to a wider range of reconnaissance problems than only aerial photography. Chapter 6 on Photographic Reconnaissance with Specialized Equipment includes a particularly challenging section on peripheral oblique photography from extreme altitudes.

In Chapter 7, we have considered the opportunities inherent in the use of small images. Small cameras and small film sizes are not a novel idea in aerial photography, but the general development program has been so much in the direction of large cameras that the proposed systematic exploitation of the advantages of smallness can nevertheless claim to be a new approach.

More general problems of the photographic method are treated in Appendix C, especially those relating to lens quality and emulsion properties. In Appendix D, brief consideration is given to the effects of atomic weapons on aerial photography.

~~CONFIDENTIAL~~

~~SECRET~~

~~SECRET~~

~~CONFIDENTIAL~~

CHAPTER 5  
PHOTOGRAPHIC RECONNAISSANCE WITH STANDARD EQUIPMENT

A. GENERAL CONSIDERATIONS

In the field of photographic reconnaissance, the tour of Air Force installations made by the BEACON HILL Study Group, together with the extensive briefings, has served to demonstrate important gaps between technical progress, operational practice and final intelligence usage. In the laboratories, we are knee-deep in elaborate equipment that is perhaps a whole order of magnitude more complicated than what we find in use in the field. Much of this equipment is of research interest only or suited for special operations. The gap is even greater between the design of the equipment and the final intelligence needs. The designer feels that, by going to larger and more expensive construction and to maximum quality, he is in some way benefiting the final intelligence officer, but the trail in between is obscure. The intelligence officer often finds that precision results are unnecessary for what he wants to know, and thus he may be tempted to discard all the unwanted large equipment.

Throughout our review of photographic reconnaissance, we have borne in mind the need to simplify Air Force problems and not to complicate them further. Our philosophy in the recommendations we shall present will lie in the direction of taking away some of the burden from the normal reconnaissance units in the interests of standardization, and of concentrating the specialized equipment in the hands of much smaller units of specialized personnel (see Chapter 12 for a full discussion of specialized reconnaissance units).

We assume that incidental small hand-held cameras, motion-picture cameras, miniature cameras, enlargers and the like are more or less satisfactory. No doubt an improvement could be effected here and there, but no tremendous dividend in our reconnaissance is likely to result. Hence, for the purposes of this Report, we confine ourselves to cameras that are airborne in more or less permanent installations and that are operated by intervalometer.

It is obvious that the problem of standardization is paramount in installations in the various operational aircraft. Specialized equipment cannot be considered except as an occasional need.

There are two immediate improvements that will raise the level of performance of aerial photography and will cope with the enhanced problems raised by the faster higher-powered new aircraft. The first is image-motion compensation, and the second is the anti-vibration mount.\* These problems are discussed in the sections that follow. Pending their complete solution, we recommend that the new and faster shutters be put into service as soon as possible.

1. Image-Motion Compensation

No extremely careful attack, comparable to the technical accomplishments of

---

\*In aerial photography the word "vibration" refers usually to the angular vibrations rather than to translational vibrations. However, if the camera system is non-rigid - such as a lens with loose elements - translational vibrations may also cause a displacement of image relative to the emulsion. Translational vibrations can cause trouble in multiple-camera installations where internal angular vibrations may be introduced.

~~CONFIDENTIAL~~

~~SECRET~~

~~CONFIDENTIAL~~

this nation in the instrumental field, has been made on the problem of image-motion compensation. The A-14 magazine is the nearest approach to a solution, but it is not desirable to have heavy and fairly delicate equipment in the magazine. Also, at high image speeds the cycling rate is inadequate. The sweep mount developed during World War II was correct in principle but needs improved construction. A first-class engineering effort is required for this problem.

In the past, image motion has been recognized as one of the limiting factors of aerial photography, along with vibration and the longer-period movements of the optical axis of the camera. However, the problem has been in a kind of twilight zone where the limitation was not so apparent. Now, airplanes are more than twice as fast operationally as in 1945, and the near future will bring planes much faster still. We must face the problem and we must have a solution ready.

One of the difficulties that has hampered this development, as pointed out to the Study Group, has been an insistence in specifications on an unrealizable perfection in the compensation. Where in the past we had zero compensation, specifications now require perhaps 99 per cent perfection. Actually, it would be a really great help to achieve 90 per cent compensation. This we believe is a figure that can be realized in practice.

It is recommended that an intensive study be made of the problems of image motion compensation affecting our operational photography during the next 10 years, and that this study be followed by the development of practicable devices that can be made standard in the Air Forces.

## 2. Antivibration Mounts

A great deal is known about the characteristics of different kinds of mounts and about airplane movements, and it is time to put this knowledge to work. Current development of suitable vibration filters is to be encouraged. Several center-of-gravity mounts have been built and their effectiveness proved. What we need now is the use of these principles and devices in operational aircraft. We realize that installation problems are often difficult. However, it is hard to believe that we must still mount cameras in frames on ordinary shock mounts which protect the equipment but do not damp out the angular vibrations. Many types of mounts such as gimbals, center-of-gravity, plywood, and rubber-in-shear have been studied in detail.

It is recommended that installation problems henceforth include antivibration as a major requirement, and that our extensive technical knowledge of mount characteristics be utilized in the antivibration features of these installations.

An example typifying the two problems discussed above, was shown to the Study Group in the installation of a 5-camera multiple-station system in an RB-36. These cameras were equipped with 36-inch f/8 telephoto lenses whose laboratory resolution is known to exceed an average of 30 lines/mm. The cameras were mounted in a welded tubular frame, which in turn was mounted in the airplane on Lord shock mounts. The cameras use between-lens shutters that have a maximum image-stopping exposure of 1/100th second. The moment of inertia of a single camera is moderate, and the 5-camera unit is not sufficiently rigid to have

~~CONFIDENTIAL~~

~~SECRET~~

~~CONFIDENTIAL~~

the moment of inertia of the assembly apply.

One needs only a glance at this equipment to know that the pictures cannot be very good and that the standard 24-inch lens in such circumstances could deliver almost as much information. The only reasons for continuing to use the 36-inch installation in the RB-36 are that a small percentage of the pictures will be really good and that, at altitudes above 40,000 feet or on bad photographic days, these lenses will deliver information not realizable with the 24-inch lens. The fault is not in the 36-inch lens but in the lack of image-motion compensation and in the mounting.

The effect of image movement on resolution patterns is a subject requiring comment, whether the movement is due to plane movement along the line of flight, or to roll or pitch, or to vibration. Unless a relatively high vibrational frequency is at work during the exposure time, one can consider that the shutter exposure intercepts a short straight line segment of the pattern of wandering of the image on the emulsion. Hence, during the exposure the image of a three-line resolution pattern will be given a vector shift in some azimuth.

Let us suppose that the vector points along the line of flight. If the three-line pattern is shifted by the width of a single line during the exposure, where for purposes of discussion we assign an efficiency of 100 per cent to the shutter, the rectangular profile of the individual line is changed into a triangular profile with the same total range of exposure from ridge to trough. One will still observe three lines in the pattern and can call the pattern resolved. However, something definitely unsatisfactory has happened to the lines in changing their profiles. If we are photographing from the air a vehicle with a rectangular projection on the ground, our photograph in the presence of the vector shift would show a truncated pyramidal structure in the one coordinate.

If the amplitude of the vector shift amounts to 1-1/2 single-line widths, one still will see three separated lines but the spaces are partially filled with light. Also, the profile of the three-line pattern will bear small resemblance to separated rectangular profiles. If the vector shift amounts to two single-line widths, then three lines can no longer be distinguished. The profile of the three-line pattern becomes a truncated pyramid with a broad top. Hence, in setting a limit to the observed resolution, we can drop back to the next larger pattern. If IM (image motion) represents the amplitude of the vector shift in inches per second, if N is the line number, and if t is the exposure time in seconds, then

$$N = \frac{0.035}{t \cdot IM}$$

Thus, if the exposure is 0.01 second, and if image motion amounts to 1 inch/second, the limiting resolution observed will be 3.5 lines/mm.

Actually, in assessing the effect of image motion on the quality of the aerial photograph in this way, we are being very conservative. It is evident that at much coarser levels of resolution the motion has affected the character of the line profiles, even though we still see three lines. The microscopic contrast suffers, and as a result objects of low inherent contrast stand less chance of being recognized. It may be that the concept of "acutance" will be useful in measuring the effect of image motion on picture quality and interpretability (see Appendix C).

~~SECRET~~

~~CONFIDENTIAL~~

~~CONFIDENTIAL~~

Figure 5-1 presents the situation graphically. We assume that the airplane is moving at 400 mph, which corresponds to a ground distance of 5.9 feet in 0.01 second. We also assume that we are dealing with verticals at 0.01-second exposure, and that the 5-camera installation yields an average image movement on the film, from vibration in roll and pitch, of 4 mils per second. The full curve on the left represents the image movement as a function of altitude for the RB-36 with the 36-inch lens, and the dashed curve shows the same for the 24-inch lens. On the right we have only the transverse vibration. In either drawing, the expected frequency distribution of image movement due to vibration is given as an insert on top of the mean image-movement position. The vertical lines near the origin give the tolerance for the 36-inch lens that will result in performance of 10 lines/mm or better. The dashed vertical lines near the origin give the tolerance for the 24-inch lens for a performance of 15 lines/mm or better. The tolerance for the 24-inch lens is taken as 15 lines/mm and of the 36-inch lens as 10 lines/mm in order to compare the two lenses for the same ground performance.

It is clear from a study of Fig. 5-1 that in the line of flight the expected performance of either the 24-inch or 36-inch lens is at a decidedly poor level even at high altitude, in terms of both resolution and contrast. Figure 5-1 is intended to prove that something must be done not only about the image movement but about the vibration also.

The present development of a between-the-lens shutter having an exposure of 1/250th second is a step in the right direction (cf. p. a-30 in Appendix C). In terms of information return, installation of this shutter in the 36-inch telephoto would result in an immediate increase in performance by a factor of nearly three.

Both image motion and vibration can be taken care of simultaneously if a 9 x 18 magazine incorporating image-motion compensation along with a focal-plane shutter at 1/800 second were to be manufactured. No one expects to use the 36-inch photographs for mapping purposes, and hence a focal-plane shutter is satisfactory. If the development of this magazine and shutter combination were pursued, the majority of pictures taken with the present 5-camera installation would have a performance well in excess of 10 lines/mm, and the contrast would be much improved. The effective performance in terms of information return could then be increased by a factor of perhaps 5 on all counts at the ceiling of 40,000 feet, and by an even larger factor at lower altitudes. Even on poor days, there would still be a gain in results because of the importance of keeping contrast above minimum values needed for recognition of various objects.

The problem of image motion will be even more serious in the case of the RB-47 airplane, and cannot be neglected. We are dealing with expensive airplanes, costly missions, and men's lives. An increase in results up to five-fold cannot be dismissed lightly.

It is recommended that a 9 x 18 moving-film magazine with focal-plane shutter be developed for general use. This focal-plane shutter should have an efficiency exceeding 70 per cent at f/6 and should have a fastest exposure of 1/800 second.

## B. DAYTIME RECONNAISSANCE

### 1. Low-Altitude Techniques and Equipment

~~CONFIDENTIAL~~

~~SECRET~~



CONFIDENTIAL

65

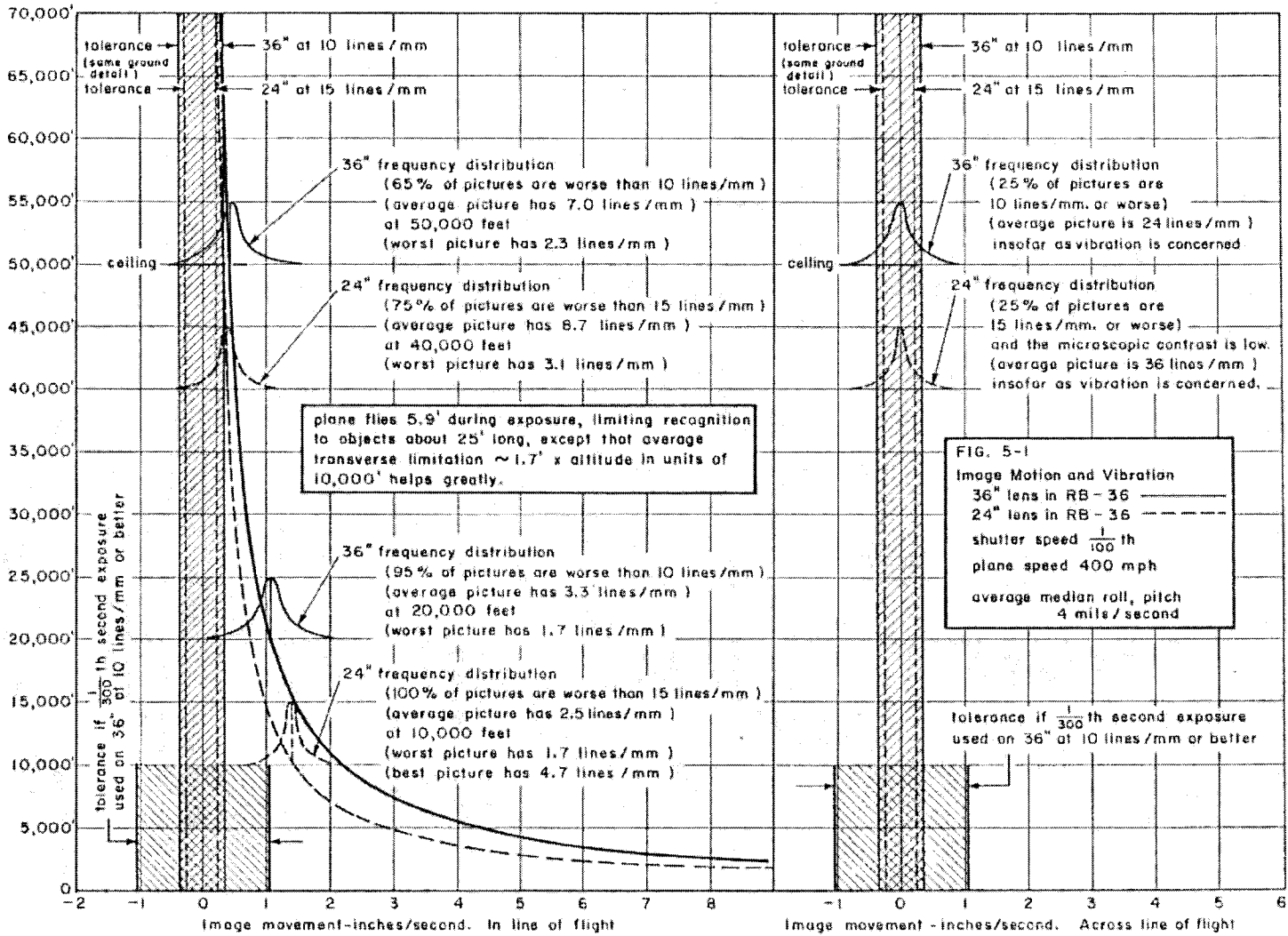

CONFIDENTIAL

~~SECRET~~

~~CONFIDENTIAL~~

For on-the-deck sweeps with fighters short focal length wide-angle cameras with high cycling rates are called for. In the range of altitude from 100 feet to 2000 feet, a small camera can accomplish almost everything that may be required. In the interest of quick cycling, 70-mm film is to be recommended in conjunction with lenses of focal length from 50 to 100 mm at  $f/3.5$  to  $f/2$ , and with focal-plane shutter speeds up to  $1/2000$  second. Image-motion compensation is a must, but vibration can be neglected if the camera is installed in a favorable part of the airplane. If space is limited, the camera should be installed in a mount that will permit the camera to be used in any one of several orientations, including the forward oblique and vertical positions. If space permits, a multiple-camera station, having forward and side obliques and vertical coverage, is to be recommended. Because of the difficulties of incorporating adequate image-motion compensation into the camera for oblique views, it is recommended that the fastest shutter speed be set at  $1/2000$  second with a 50-mm lens at  $f/3.5$  and with image-motion compensation tied to a mean image movement over the field, favoring the more distant objects. The four cameras could be mounted in about a cubic foot of space and might conceivably be combined into a single unit for ease of handling and installation.

If such a camera has image-motion compensation good to 90 per cent of the ideal value for at least the vertical installation, a shutter speed of  $1/2000$  second, and a 50-mm  $f/3.5$  lens, then in a fighter plane traveling 600 mph at 500 feet altitude, a performance of 25 lines/mm should be realizable on at least 50 per cent of the pictures. The ground resolution in this case, corresponding to a resolution of 25 lines/mm, will amount to 2.4 inches, which in turn will permit objects of about 10 inches on a side to be recognizable.

As an alternate possibility to avoid the starting and stopping of the film for 60 per cent overlap where image-motion compensation is provided for by moving the film, one can consider use of 5-inch wide film moving uniformly for image-motion compensation. Such a film would be equipped with two taking lenses of 50 mm focal length at  $f/3.5$ , mounted side by side, each covering a 60-mm wide format with pictures taken in parallel strips along the film. The pictures will be staggered in time along the line of flight. The pictures will then be made with 50 per cent overlap. The rate of film movement is then tied in with the rate of image movement, and the cycling time for the shutters will be set by the time required for the film to travel a distance of about 60 mm. At 600 mph, with a 50-mm lens from an altitude of 500 feet for a format of 60 x 60 mm, the image movement amounts to 88 mm/sec and the recycling of the shutter to approximately 1.5 times/second. If a rotating-sector type shutter is employed, the recycling time can be set at a much higher value and the film movement will not be excessive. Inasmuch as everything is tied in with the image movement, faster cycling corresponds to the use of even a faster airplane, a lower altitude, or both.

If 70-mm film is used with a 50-mm  $f/3.5$  lens at an altitude of 500 feet and plane speed of 600 mph, the cycling rate will amount to 3.7 frames/second for 60 per cent overlap and 60 x 60 mm format. The film, in this case, will have to move intermittently, in which case the motions of image-motion compensation and film transport can be separated in several ways. A cycling rate up to 10 frames/second ought to be possible, which will provide for either a faster airplane, lower altitude, or both. There is in existence a successful 70-mm magazine with Geneva movement, a rotating-sector shutter, and speeds of 10 and 20 frames/second.

~~CONFIDENTIAL~~

Consequently, the proposed specifications on the camera discussed above are not excessive.

It is recommended that a small, fast-cycling camera of approximately the properties described above be developed for low-altitude sweeps, and that multiple-station mounts be planned for where possible. The image-motion compensation for vertical views should be at least 90 per cent effective; and for side and forward obliques, a suitable compromise on image motion is to be made. The taking lens should have a 50-mm focal length at  $f/3.5$ , and should cover a 60 x 60 mm format. The fastest shutter speed should be 1/2000 second which indicates a focal-plane shutter, possibly of the rotating-sector form.

The 6-inch Metrogon in the present K-17 camera is not suitable for use in low fighter sweeps because of slow cycling rate and excessive focal length beyond actual needs. Moreover, the 9 1/2-inch film is not really needed for low-altitude applications (i.e., less than 2,000 feet).

Very little combat flying will be carried on in the range of altitudes from 2000 to 10,000 feet over well-defended areas. Where photographs must be taken in this range of altitudes, the 6-inch lens on 9 x 9 format will deliver the most information.

The existing K-17 camera with 6-inch lens and A-14 magazine can do quite a good job with the lens stopped down to  $f/8$ . There is a need sooner or later for undertaking the task of improving the 6-inch lens performance. The present  $f/6.3$  lens is doing fairly well in covering a 90 degree diagonal, but better laboratory performance is highly desirable. If the present performance at  $f/8$  could be worked into an  $f/6.3$  design, the photographs would be noticeably improved. The present limitations on performance with the K-17 and A-14 magazine are set by the lens quality more than by any other single factor. Vibration is more or less negligible owing to the short focal length and high shutter speed. Image motion would be serious except that the A-14 magazine eliminates it. However, the A-14 magazine or equivalent needs to be used more generally by the reconnaissance wings.

## 2. High-Altitude Verticals and Obliques

For altitudes from 10,000 to 30,000 feet, the standard lenses of focal length from 6 inches to 36 inches are preferred, with the bulk of the work being accomplished by the 12-inch and 24-inch lenses. Where space permits, a Tri-Met installation should also be used. It is risky to use only a 6-inch camera in the altitude range from 10,000 to 30,000 feet, owing to reduced information returns and to the great danger of aborted missions on bad photographic days. At the other extreme, for most purposes the use of a 36-inch focal length in the altitude range from 10,000 to 30,000 feet will result in detailed information at the expense of coverage. However, for oblique pictures the 36-inch lens is to be preferred.

As described earlier in this Chapter, image-motion compensation is mandatory for good performance of the standard equipment along the line of flight. The A-14 magazine takes care of this problem reasonably well but has only a 9 x 9 format. The 24-inch and 36-inch

~~CONFIDENTIAL~~

~~SECRET~~

lenses cover both a 9x18 format for which image-motion compensation is badly needed. An earlier recommendation takes care of this deficiency. Similarly, mount vibrations become important for the longer focal lengths, and the recommendations given earlier in this Chapter should be followed.

The higher the altitude, and the worse the haze, the more one should make use of the 36-inch lenses. Similarly, for high oblique pictures, the 36-inch lens is preferred.

Once image-motion compensation and vibration have been reduced to unimportant residuals, the lens quality of the 5-inch, 12-inch and 24-inch will be found deficient at full aperture. Consequently, attention should be given to improving the performance of the standard lenses, provided this improvement can be obtained at only a moderate increase in cost and complexity. The photographic details are discussed in Appendix C.

In the range from 30,000 to 60,000 feet, the 24-inch and 36-inch lenses will be required to maintain adequate information return. Again, image-motion compensation and anti-vibration mounts are mandatory, as proved by the typical data of Fig. 5-1. As mentioned earlier, it is desirable for the performance of the standard 24-inch f/6 lens to be improved after the more important problems of image-motion compensation and vibration have been surmounted.

For high obliques, the 36-inch lens should be used almost exclusively in this altitude range. As described previously, the faster shutter soon to become available will do much to improve average picture quality.

Although lenses considerably larger than the standard 36-inch will deliver even more fine detail at great altitudes, their wide-scale use is believed to be unnecessary. These lenses are more suited for the special purposes described in Chapters 6 and 12. Moreover, the uncertainty of focus of large lenses, coupled with the use of mirror installations, flexure, special installation problems and the like, all argue against having these manufactured in quantity for use in the regular reconnaissance units.

It is recommended that no lens larger than the 36-inch for 9x18 format be employed in regular reconnaissance units. Equipment larger than the 36-inch camera and special equipment of all kinds can be more effectively used by the specialized units described in Chapter 12.

#### C. NIGHTTIME RECONNAISSANCE

The war in Korea has placed extremely strong emphasis on the importance of night photography, and on the need for a night capability in aerial photography that can yield quick assessment of a fluid battle situation. Time after time, day photographs will show an apparently deserted countryside or village. Night photographs of the same areas may show beehives of activity.

To some extent, we shall have a reconnaissance capability through our regular night photography employing verticals, or from drones or from terminal missiles. These techniques are discussed below. However, there is another rather difficult technique of special interest, which involves cooperative planning between the Army and the Air Force.

We consider that one or more night photo-planes will be flying behind our own

~~CONFIDENTIAL~~

~~SECRET~~

~~CONFIDENTIAL~~

~~SECRET~~

lines far enough back to be safe from all enemy ground fire, and high enough to obtain a clear photographic line of sight of critical enemy areas or of enemy terrain to be photographed. The photo-planes are in suitable communication with ground artillery officers. The artillery is then to fire high-illumination photo-flash bombs in suitable shells to burst at suitable altitudes over the areas to be photographed. In this technique, the photographic airplanes are spared the necessity of carrying flash bombs and of risking enemy anti-aircraft fire.

As a typical operation, we can assume that we are using a liaison plane such as the L-5 developed primarily for daytime spotting purposes, and under Army control. In effect, we are extending the already existing daytime arrangement to night use, a capability we do not have at present. Let us assume that this particular operation will have the L-5 flying at 5000 feet altitude back of the immediate battle lines over friendly territory. When the pilot gives the word that his plane is in position for photographs according to his flight plan, the artillery will fire the flash-bomb shells at even intervals of perhaps 10 seconds to burst at 10,000 feet over preselected areas to be photographed. The cameras will be operated by photoelectric trigger and will be aimed at the known oblique angle laid out on the flight plan. It would be helpful in spotting and timing if the artillery were to fire a preliminary star shell or shells in offset or in a pattern to guide the camera observer without tipping off the enemy that photographs are to be taken. The opportunities for spoofing, diversions and the like are obvious, and should be employed.

We note also that the RF-84F is not equipped for night operations with flash bombs. If the artillery handles this bulky problem, one sees that the RF-84F will become available for night photography when this capability is needed.

Wherever possible, the photographic airplane should be at a distance closer than 10 miles in order to obtain scale and increased information. Even at 10 miles distance and at 15,000 feet altitude, with a 36-inch camera, one can expect to observe vehicles of all kinds that are in the open. The transverse scale with such a camera at such a distance would be approximately 1:20,000. The ground "detectability" at the same distance would be of the order of 6 feet on a side for the size of object detected.

Stereo pairs can be obtained if the artillery fires photo-flash shells several seconds apart. Different aspects of the target can be obtained from either successive photographs minutes apart, or from different airplanes using the same flashes. It might even be possible to have pictures made all night long over an active battlefield hundreds of miles in extent, the expectation being that the technique will prove so useful as to be in constant employment. The photographic processing might be carried out in the airplane and the pictures might be dropped by parachute. Greatest tactical returns are indicated from procedures that get the requisite information to the battlefield commanders within the shortest possible time after the pictures are taken. Certain operations may permit Land-type quick processing with photo-interpretation done in the airplane and the information radioed to the field officers.

A tactical plan of operations can be worked out when the use of such a technique is given detailed study. For the present purposes, we merely outline the possibilities.

~~CONFIDENTIAL~~

~~SECRET~~

~~CONFIDENTIAL~~

Operational experiments are recommended leading to a procedure for night oblique photography for tactical purposes, in which the photo-airplane remains over friendly territory and the flash bombs are fired by ground artillery. The very closest cooperation with the Army is needed in all phases of the development and in the operational applications.

As a result of the pressure brought to bear by Korean needs, the customary vertical night photography has been undergoing development in a way that promises before long to give us an adequate capability in so far as flash bombs and camera equipment are concerned. Night cameras for the 24-inch and 36-inch lenses now under development will have image-motion compensation. As discussed under daytime photography, these cameras should be mounted in a proper antivibration mount. In fact, because exposure times used in the flash-bomb type of night photography are appreciably longer than those used in daytime reconnaissance, it is all the more important for the mount characteristics to be perfected. However, when we speak of "perfection" here, we do not mean absolute 100 per cent perfection, but an attainment that is within a reasonable tolerance and that is practicable.

The present program on night photography has emphasized the use of flash bombs, with most of the illumination concentrated in the red and infrared portions of the spectrum. Concurrently, 24-inch  $f/3.5$ , 36-inch  $f/3.7$ , and 48-inch  $f/4.5$  lenses for 9x18 format have been developed, the first two of which will be in production in modest quantities before long. In addition, we have the older 12-inch  $f/2.5$  for a 9x9 format, and the 7-inch  $f/2.5$  for a 5x5 format. A 6-inch  $f/2$  lens for a 5x5 format is under development. This list of equipment seems to be entirely adequate for any contemplated nighttime program employing conventional photography. Once again, it is recommended that the 48-inch lens not be used in regular reconnaissance wings, but be set aside for use by the special units discussed in Chapter 12 of this Report.

It is probable that the above lenses are of sufficient quality to be satisfactory for some time to come in our night aerial photography by flash-bomb techniques. On the whole, the inherent quality of night photographs is low, owing to uneven illumination, to haze directly beneath the airplane, and to the longer exposure times. The present night photographic quality is low also because of lack of image-motion compensation and of antivibration mounts.

Members of the Study Group have examined a roll of negatives taken during the daytime under poor photographic conditions where image motion is pronounced. In addition, the lens is out of focus. The pictures are very "flat" and lack detail to a gross degree. In fact, the image motion amounts to approximately one millimeter along the line of flight. There is no doubt that the quality of these photographs would be greatly improved, even with the bad haze, if the image motion were eliminated and the focus properly set. The photographs would still be of low quality owing to the haze, but would nevertheless show much interpretable detail. The photographic quality of this roll of negatives is very similar to what one would obtain with present night techniques, which certainly can be very considerably improved.

As in the case of daytime photography, image-motion compensation is a must. Antivibration mounts are a must also because of the slow exposure times, fast airplanes, and

~~CONFIDENTIAL~~

~~CONFIDENTIAL~~

long focal lengths. Recommendations here are identical with those made in the section on daytime reconnaissance.

1. Low-Altitude Techniques and Equipment

There are at least four techniques suitable for night photography at low altitude (i.e., below 2500 feet). The first of these is already in satisfactory operational use. This is the system of ejecting flash cartridges at regular intervals sequenced with the film and interval. If image-motion compensation and the antivibration mount are sufficiently achieved, it is likely that the flash cartridge will yield night photographs of good quality. For these low altitudes down to on-the-deck sweeps, it is recommended that the 70-mm camera described earlier under the discussion of daytime reconnaissance be adapted to night photography by replacing the 50-mm  $f/3.5$  with a 100-mm  $f/2$  for the 60x60 mm format. By proper sequencing, one can obtain the usual stereo pairs. Alternatively, the camera described in the same section, making use of 5-inch film with two lenses, can be used for night photography with flash cartridges. Here again, we recommend the use of a 100-mm  $f/2$  lens for each of the two lenses needed for the stereo pairings.

The second technique that needs renewed emphasis is that of the Edgerton flash unit. Developments in flash techniques since 1945, in the direction of more illumination for the same weight of equipment and less weight for the same illumination, promise to pay new dividends in night electric flash photography. For low-altitude work, quite adequate illumination can be obtained with equipment of moderate weight. Moreover, the same 70-mm or 5-inch film cameras described earlier can be used quite successfully with the Edgerton flash.

The third technique that may be of significance, when combined with the ultra-fast emulsions soon to appear, is the night transverse strip photography introduced during the past war by Dr. O'Brien of the University of Rochester. Following the war, a very intensive program was carried through on night strip photography, but the results were inadequate. The level of illumination and the limited speed of lens and film combined to prevent obtaining an adequate exposure level. Now, however, by making use of all the improvements since 1945 in optical systems, illuminants, film and processing, we should be able to obtain usable photographs for altitudes from 200 to 2500 feet. The original development made use of infrared illumination. However, it is debatable whether the plane would be any more detectable if ordinary yellow and red were included in the illumination, rather than infrared alone. For an observer on the ground, there is only a flash of light equal to the exposure time of perhaps 1/50 second. Before and after the light passes over him, the same observer could more readily see the plane silhouetted against the slightly luminous night sky background or from its exhausts than from the strip of light beneath the plane. Of course, all light from the illuminating system not in the transverse strip - that is, stray light - should be eliminated by suitable design of the equipment.

The fourth technique that may be of importance involves the burning of magnesium powder, or perhaps ribbon, at a constant rate from beneath the wing of the airplane. This technique has been tried out recently by Brig. General George W. Goddard. Owing to the hazards of low-altitude flying of this kind where the plane is far more brightly illuminated than the ground, it seems that this technique may be prohibitive for a manned airplane over enemy-held territory.

~~CONFIDENTIAL~~

~~SECRET~~

~~CONFIDENTIAL~~

For tactical purposes, it may be feasible to employ the technique in combination with a drone either for visual reconnaissance or for strip photography by the flare. The magnesium burns with an intense green light to which the eye is especially sensitive. However, the observer in the spotting plane may have to be some distance away, a fact that will reduce the value of his visual reconnaissance.

For low-altitude night photography, we recommend

- (a) The 70-mm and/or the 5-inch film cameras be adapted for night use in standard reconnaissance units by replacing the 50-mm f/3.5 lens with a 100-mm f/2;
- (b) The present possibilities of the Edgerton flash technique be explored and the technique perfected for low-altitude night photography.
- (c) An engineering study be made of the present possibilities for night transverse strip photography. Combinations of visual illumination with Tri-X film, visual illumination with infrared film, and infrared illumination should be compared.

## 2. High-Altitude Verticals

In the altitude range from 2000 to 10,000 feet, it seems desirable to make use of the ejection cartridge technique as the standard procedure in the regular reconnaissance units. In this range of altitude, it is no longer advisable to use the 100-mm lens with the 70-mm or 5-inch film, but instead to use the 6-inch f/2 and 12-inch f/2.5 cameras. It is not considered advisable to use the Edgerton flash technique because of the vulnerability of the airplane and because the flash equipment must be much heavier. It is also not considered desirable to use either the transverse strip technique or the burning magnesium; technical limitations rule out these methods anyway.

At altitudes of from 10,000 to 20,000 feet, it seems advisable to use mostly the 24-inch f/3.5 lens except where need for finer detail demands resort to the 36-inch f/3.7 lens. Above 20,000 feet, only the 36-inch f/3.7 should be used, if available, or, otherwise the 24-inch f/3.5 lens.

Above 10,000 feet and for some operations below 10,000 feet, it will be necessary to use flash bombs for the illuminant and as the standard technique in regular reconnaissance units. This Red Light program seems to be well in hand, and in need of no other recommendations except that image-motion compensation be used with the 24-inch and 36-inch cameras and that antivibration mounts be used.

## 3. High-Altitude Night Obliques

At the present time, we have no capability for night oblique photography. Yet anything that can be done to permit the plane to avoid strongly defended areas is worth while. Night photos made in such areas by means of vertical photography represent a type of activity with a high attrition rate and, therefore, a high cost per picture.

There are four techniques of importance for night missions seeking photographic coverage of well-defended areas. The first and most productive of these techniques involves the use of a drone airplane equipped with night cameras and cartridges, controlled by a mother airplane flying many miles away. The drone technique in the foreseeable future seems confined to tactical usage because of the recovery problem.

~~CONFIDENTIAL~~

~~SECRET~~



~~SECRET~~

~~CONFIDENTIAL~~

The second technique makes use of a terminal missile which sends information to the airplane by photoelectric methods (see Chapters 8 and 11).

The third technique is one that makes use of high-altitude oblique photography from distances up to 20 miles from the target. In this case, the flash bomb must be lobbed over the target several minutes before picture time. Because of haze and the need to keep the direct bomb illumination out of the field of view, one must provide for powered flight for the flash bomb, with its terminal altitude over target of perhaps 10,000 feet. It may be that the terminal missile of the preceding paragraph could carry the flash bomb.

The fourth technique is the tactical use of night oblique photography (described above at the beginning of this section on night photography) where the flash bombs are sent over the areas to be illuminated by the ground artillery. Because of the tactical importance of this technique, the description that would normally be given here has been placed earlier in the discussion.

~~CONFIDENTIAL~~

~~SECRET~~

~~SECRET~~  
~~CONFIDENTIAL~~

CHAPTER 6  
PHOTOGRAPHIC RECONNAISSANCE WITH SPECIAL EQUIPMENT

A. EQUIPMENT

The potentialities of the photographic method for aerial reconnaissance go far beyond those of the conservative and standardized equipment described in Chapter 5. We have been forced by prudence to make a division between the requirements of the regular reconnaissance units of the Air Force and what can be accomplished by special equipment on special missions. Very probably, 95 per cent of what the Air Force really needs to know can be satisfied by the standardized equipment discussed in Chapter 5. The other 5 per cent can be collected by means of nonstandard equipment of high technical quality designed for a particular purpose and used by trained personnel.

Before considering specialized equipment in detail, it may be interesting to speculate on the ultimate possibilities of photographic reconnaissance. If the photographic method were to be applied with no holds barred, we could bury ourselves in enormous masses of photographs of large scale and high quality. We could gather a quantity of data a thousand or more times our actual needs. We could carry our photographic resolution down to as fine a level as three seconds of arc as seen from the airplane, which corresponds to a resolving power of one foot at a distance of 14 miles, and this angular resolution can be achieved from horizon to horizon for thousands of miles. Given heavy bombers flying in daylight at 35,000 feet at 350 mph, we could cover all of the Soviet Union and a large portion of China at a scale varying from 1:20,000 to 1:100,000 in about 150 hours of flying time. Thus, 15 unimpeded airplanes flying in pattern under CAVU (ceiling and visibility unlimited) conditions could cover this area of millions of square miles and photograph, in about 10 hours' total elapsed time from border crossing, everything we might want to know down to objects several feet square in size. Actually, enemy and weather prevent such a mission.

Similarly, several rocket flights on (improbable) perfect photographic days could return to us complete information on the existence and location of all the air bases and small towns in all of the Soviet Union and parts of China. Let us assume that the rockets will go in parallel flights from the Arctic Ocean south over the Soviet Union. The rockets might be recovered in the near East and in the Indian Ocean. The maximum altitude can be taken to be 700 miles. With a rocket vehicle fitted with a specially designed 36-inch panoramic camera with 9-inch film, an uncamouflaged air field might be detectable at ranges up to 1500 miles (to be conservative) in excellent weather.

Photographic methods carried similarly to the extreme for balloon flights could cover strips 300 miles wide transverse to the line of flight and for as long as daylight and film hold out along the line of flight. Night flights, with the balloon equipped with a 36-inch f/6 lens of telescopic quality, might photograph artificial lights from streets, houses and factories from hundreds of miles away. For example, a telescope of 6 inches aperture can photograph a 100-watt light from a distance of 250 miles in an exposure of one second. A suitable camera can detect lights of cities at very great distances. Wintertime flights with balloons in northern latitudes (Moscow is only 700 miles from the Arctic Circle) could pick up lights at

~~CONFIDENTIAL~~

~~CONFIDENTIAL~~

~~CONFIDENTIAL~~

~~CONFIDENTIAL~~

~~CONFIDENTIAL~~

great distances (300 miles), covering a strip 600 miles wide and perhaps 5000 miles long at a vertical scale of 1:30,000. The balloons themselves would be almost undetectable by any ordinary means because of the long nights.

It is evident that, to be practical, one must always include weather and equipment limitations in his analysis of a problem. The high probability of cloudy weather over the Soviet Union makes a very deep cut into the photographic results to be expected. On the equipment side, we do not as yet have vehicles that can make bold penetrations without being detected and intercepted. Our balloon techniques are still in a primitive stage, compared to what is needed. We do not have the type of rocket mentioned above, and none is expected for many years to come.

Nevertheless, we do have many types of equipment, vehicles and techniques that are nonstandard and unsuited to mass use in the regular Air Force reconnaissance wings. And there are intelligence needs of critical importance that can be satisfied by a few missions in a few aircraft and with a few well-selected, possibly elaborate items of equipment. In Chapter 12 of this Report, we discuss the need for special reconnaissance units to handle special equipment and special operations.

#### 1. Special Large Lenses

Special large lenses perform the usual pictorial photography with the help of fast-acting shutters. The lenses are large on the three counts of aperture, focal length and format size. The lens types available to us or beyond the lens design stage are:

- (a) 36-inch f/8.0 apochromatic lens for 9 x 9, format. Two exist.
- (b) 40-inch f/5.0 telephoto for 9 x 9 with automatic focusing, thermostating.  
This lens is available for use in quantity of about 150 units.
- (c) 48-inch f/6.3 telephoto for 9 x 18. In limited production of about 200 units.
- (d) 48-inch f/4.5 lens for 18 x 18. Prototype being built. Intended primarily for night photography in the infrared.
- (e) 48-inch f/8 lens for 9 x 9. Apochromatic and intended for use with color film. Experimental model partially built but discontinued. Could be finished at any time, and is a top-quality lens.
- (f) 60-inch f/6.0 telephoto, folded, for 9 x 9. One built and used in World War II. Could be produced at any time. Small enough for fighter plane.
- (g) 60-inch f/5.0 telephoto, for 9 x 18. Evacuated to prevent internal heat waves, and sealed against moisture and dust. Experimental model discontinued in 1945 but could be finished.
- (h) 72-inch f/5.6 lens for 18 x 18. A Canadian lens under development.
- (i) 96-inch f/8.0 lens for 18 x 36. Experimental model nearing completion.
- (j) 100-inch f/10 lens for 9 x 18, folded. Six have been made and are in use.
- (k) 144-inch f/8.0 lens for 18 x 36 to be folded. Experimental model nearing completion.
- (l) 240-inch f/8.0 lens for 18 x 36, folded. One model completed, in use.  
Two more sets of glass blanks available.

Of the lenses listed above, only the 40-inch f/5 and the 60-inch f/6 are perhaps

~~CONFIDENTIAL~~

~~CONFIDENTIAL~~

small enough to be used in fighter planes, and were designed for this specific purpose in 1941. Both lenses are capable of averaging 25 lines/mm on good photographic days when carefully focused and used with a K-22 body and a shutter speed of 1/800 second. For best results, they should be used by specially trained personnel.

The other lenses on the list are too large to be used in fighters and are suitable only for use in bombers. The 96-, 144-, and 240-inch are so large as to fit only into the heaviest bombers - such as the B-29 - but even here the installation is a special, costly job. The 100-inch has been used in open bomb bays of a plane as small as the B-17, but not under good circumstances for precision photography.

All the lenses on the list are suitable for use in either verticals or obliques. The expected average performance in the air in terms of average results on good and bad days is portrayed on the curves of Fig. C-1, Appendix C. We can anticipate resolving powers of three to five seconds of arc should be obtainable on good photographic days if trained personnel handle the cameras.

Apart from considerations of weight, size and cost, there is another reason for not using large lenses in the regular reconnaissance wings. A lens such as the 100-inch f/10 requires that good men be trained to use the camera properly and that these men be equipped with certain aids not commonly available outside optical laboratories. Moreover, these men should be under the supervision of individuals with thorough scientific backgrounds in the field.

For example, the usual photographer is aware that a lens must be properly focused. However, the practice with standard aerial lenses is to focus these lenses in their cones at the factory, a job that is thought to be done once and for all. Quite often in the field, the technician may reset the focus by his own standards, but he also will hope to focus his camera once for all time. In practice, different observers disagree widely as to the correct focal setting, owing to wide discrepancies between visual and photographic focus. One has to focus for a given aperture, color of light source, emulsion, target contrast and target size. If these conditions change, the focal setting may have to change. Hence, the observer in the field is very likely to disagree with the factory setting, but is probably not any closer to an optimum answer in view of variable conditions.

For the larger lenses listed above, the focus itself becomes sufficiently variable with temperature, air density and ground distance to be troublesome. For these lenses, the ground is not at infinity. Many photographers may be aware of the need to focus for ground distance, but many are not. For the smaller lenses, it does not cause an important effect except at low altitudes. For the 240-inch lens, the effect is very important even at 40,000 feet. For this reason, the 40-inch f/5 telephoto has built-in automatic focusing, and can go down to 2500 feet or up to 100,000 feet and still maintain its focus. Automatic focusing devices, however, are too complicated for even specialized use.

The air density effect is not commonly known. When the camera is taken to higher altitudes, the air leaves the lens and the individual elements become more highly refracting. The focus is shortened. The effect for the 144-inch lens amounts to 2.5 mm at 40,000 feet, a considerable error at f/8.

~~CONFIDENTIAL~~

~~CONFIDENTIAL~~

Temperature causes trouble on two counts. There is a change of focus with ambient temperatures under equilibrium conditions which must be allowed for adequately. Thus, if the 144-inch lens is in thermal equilibrium at 70°F, at -30°F there will be a change in focus of about 4.2 mm. This change is quite substantial and cannot be neglected.

The other thermal change of focus is caused by thermal gradient, and this effect can become very serious indeed. For example, if the 144-inch lens is cooling at the rate of 10°/hour, the focus will be shorter on this account by perhaps 3 mm. If the cooling rate increases to 20°/hour, the focus may shorten by 6 mm. Finally, as the lens settles into thermal equilibrium, the focus may return to the equilibrium value quite rapidly, perhaps at the rate of one mm every five minutes. The depth of focus at  $f/8$  for a resolution of 10 lines/mm is of the order of 2 mm.

Lens systems from 40 inches to 72 inches can be placed in thermostated compartments or heated within the cameras or focused sufficiently well according to known conditions. However, the thermal gradient remains troublesome. For such use, the cameras ought to be in a constant temperature space for over four hours before picture time and focused for this temperature. This temperature should be maintained in the camera compartment.

It is clear that unless special attention is given, a large lens may be out of focus, to the extent of 3 mm or more, at any particular time in the air. The pictures taken under such circumstances are likely to be very poor and will not justify use of an expensive large lens. Sharp focusing is an absolute essential of good aerial photography. Untrained observers with the large lenses are usually not even aware that the focus shifts around over a large range. Even trained observers must know how to take into account the various factors.

The Boston University Optical Research Laboratory has devised a method of focusing in the air. One takes a Land photograph with a small test camera on a tilted plane and reads the focal setting as from a ruler. This is an excellent way to simplify the focusing problem, and to make it possible for average observers to get good results. Its use is recommended on all lenses of 96-inch focal length or larger.

Large lenses cannot receive ordinary maintenance. Disassembly, for example, of the 60-inch telephoto by unequipped technicians has made this lens of no value for photography. Trained workers require test plates, flats, collimators, special film holders, microscopes, gauges etc. to accomplish adjustment of the largest lenses even in the laboratory. We cannot expect untrained personnel to do this kind of work. Large equipment requires a certain amount of "nursing" and will not perform properly except in the hands of a trained operator.

Large lenses should be used in suitably designed camera bodies, with image-motion compensation in antivibration mounts. It is even more important to have image-motion compensation here than it is in the case of standard equipment. There is little point to using the larger expensive equipment only for the purpose of magnifying the aircraft's motions.

Some of the larger cameras for example, the 60-inch  $f/6$  telephoto, and the 100- and 240-inch cameras - are folded up with two mirrors to achieve compactness. Mirrors can be both an advantage and a disadvantage. If they are loose in their cells, mirrors become portable seismographs and magnify the plane's vibrations. If tight in their cells, mirrors may not have an adequate optical figure and may spoil the picture quality. Considerable care must

~~CONFIDENTIAL~~

~~SECRET~~

~~CONFIDENTIAL~~

go into the design of mirror cells to avoid these two troubles. The average person understands looseness and is tempted to tighten bolts until the mirror is badly warped. Few people understand that the warping of a mirror surface by only a few millionths of an inch may impair the optical performance.

Even if mirror cameras are properly made and adjusted, it is vital that field technicians be restrained from taking the camera apart and readjusting it. All our experience from the past war indicates that it is a rare event for a reassembled large lens to give the results for which it was designed. Usually the quality falls so drastically as to destroy the effectiveness, and the large lens made at high cost and with great care is considered a bad piece of equipment and discarded.

The only cure for this situation is to insist that all the lenses and accompanying equipment listed above be used by and under the constant control of trained personnel of specialized reconnaissance units.

## 2. Spotting Cameras

For many purposes, the cameras listed above cover a larger area than is really needed, and are suited to survey work of large tracts of territory where it is not known in advance what the important reconnaissance details may be. Such cameras can be used, for example, for peripheral surveys of enemy territory where the plane is flying 20 miles or more offshore. These same large-coverage cameras are indispensable for use without an observer or in an unmanned vehicle. Coverage must make up for uncertain sighting.

For spotting purposes, another class of cameras is useful. Here, the reconnaissance details to be observed have been selected from photographs made earlier and more information is sought. Most often, the focal length of the spotting camera will be large because by implication one is seeking more detail. Also, on poor photographic days (compare Fig. C-1, Appendix C) it takes a long focal length lens to give adequate information return. Or, from another point of view, for high oblique photographs where haze is practically always present even on good days, the long focal length lens is a necessity.

Actually, at the present time we have no spotting camera distinct from the large aerial cameras listed above. We have been using six existing 100-inch folded systems for experimental oblique photography. These photographs are capable of showing many areas of interest, but of small angular size. It would be worth while to be able to keep such areas under surveillance by means of spotting cameras of focal length up to 240 inches, but designed to be extremely compact with a necessarily small angular field.

In 1945 at Harvard's wartime optical research laboratory, a spotting camera was designed; in those days it was called a "scout" camera. The lens was a 48-inch  $f/8$  telephoto covering a  $3\frac{1}{4} \times 4\frac{1}{4}$  format. The optics were folded in a Z-shape with two mirrors so that the instrument was of the order of  $12 \times 12 \times 7$  inches. With the accompanying  $10 \times 50$  binoculars mounted in correct and rigid alignment on top, the instrument would have weighed about 25 pounds. The scout camera was never finished because the war ended. Nevertheless, the conception was a good one and would be useful even now.

There are available a number of optical means for obtaining small-field, compact systems of high quality. The simplest of these is the ordinary Cassegrain telescope with

~~CONFIDENTIAL~~

~~SECRET~~

~~CONFIDENTIAL~~

~~SECRET~~

two mirrors. However, there are others with all-spherical surfaces, moderate-size formats and flat image surfaces, with speeds from  $f/3$  to  $f/20$  or so, according to what is desired. Spotting cameras of 240-inch focal length can best compromise on speeds around  $f/15$  to keep weight to a minimum. For such a camera, it would be worth while to use the very fastest emulsion in the red and infrared to offset the low lens speed.

As a typical example of a spotting camera, there exists a very compact design of a 60-inch  $f/3.3$  covering a  $3\text{-}1/4 \times 3\text{-}1/4$  format with images of telescopic quality throughout. Here, one can use a fine-grain slow emulsion to maintain contrast and to obtain resolving powers in the air up to 30 lines/mm. Or, one can use a shutter speed of  $1/2000$  second with Super-XX in order to minimize vibration.

Obviously, there is no point in using a long focal length lens for spotting purposes if image motion or vibration gives low resolution values. The great danger of using a 240-inch  $f/15$  is that vibration will spoil the high oblique work. One can build a 100-inch  $f/10$  for a  $5 \times 5$  format - a lens that can be mounted in a box measuring  $22 \times 22 \times 15$  and that will weigh about 60 pounds or so. Where mirror systems are used, great care must be exercised in the mounting details to prevent the mirrors from being warped by their cells or, conversely, to prevent the mirrors from rattling and exaggerating the already bad vibration.

Once in a while, it will be necessary for the spotting camera to do high oblique work over new territory where a large-coverage lens is more to be desired. Such will be the case with flights of rockets, the X-1 and X-2, fighter planes, and the like, where smallness of equipment is essential. Consequently, great care must be exercised to prevent an aborted mission due to inadequate directing of the spotting camera. Where a plane can have a separate observer to handle the camera, the observer should have a regular sight without lenses and a pair of binoculars bore-sighted with the camera. The observer should be able to see both forward and to either side of the airplane in order to determine where he is and what he wants to photograph. For planes with only a pilot, the spotting camera will have to be very small and hand-held, or the pilot must be equipped with a simple sight servoed to the camera. If the plane has a bomb-director periscope, the camera should be servoed into the system. If it is necessary to have the camera fixed in an oblique position rigidly in the airplane, the pilot or extra observer should have available a sight aligned with the camera, and the airplane itself must be directed.

Work should be continued on ways and means of reducing the size and cost of long focal length lenses or mirror systems and on the optimum designs for spotting cameras for focal lengths from 48 inches to 240 inches. The installation and use problems should receive full attention for each kind of aircraft to be used. Image motion, vibration, and shutter speed must be given full weight in assessing possible designs.

### 3. Panoramic Cameras

The most cogent criticism of large panoramic cameras is that they give too much information, rather than too little. If the ultimate possibilities of panoramic cameras

~~CONFIDENTIAL~~

~~SECRET~~

~~SECRET~~  
~~CONFIDENTIAL~~

were realized, we would be using enormous quantities of film far beyond our capacity for processing the data into intelligence. Consequently, panoramic cameras become special tools to be used for wide-area reconnaissance over more or less unknown territory.

There are several kinds of panoramic systems but all have in common a transverse sweeping motion relative to the film, whether the camera is fed by a rotating prism or mirror, whether the camera rotates as a whole, or whether the lens rotates inside the camera. We need not go into details of construction here. The photograph taken by a panoramic camera has cylindrical distortion, brought about by the projection of the practically flat surface of the earth through a point of perspective onto a concave cylindrical surface containing the emulsion. There are several ways of rectifying the negative back onto a comparatively undistorted print, and one can work up to within 10 degrees of the horizon in a useful way. On an original print taken with the existing 48-inch panoramic camera, interpretable detail can be followed to within 5 degrees of the horizon on what must have been a first-quality photographic day. The altitude was 20,000 feet; the most distant interpretable detail on this print lies 45 miles from the plane, yielding a 90-mile-wide strip from only 4 miles altitude.

The panoramic method becomes even more spectacular from altitudes of 45 miles, such as would be available with the X-2. Here, one can photograph interpretable detail on a strip 600 miles wide. In excellent weather, there is no significant change in haze between ordinary flight ceilings of 7 miles and 45 miles altitude.

Two types of panoramic cameras are available - the 6-inch and the 48-inch - and a 24-inch is under study. The 6-inch wieldable camera is a strip camera mounted in such a way that the entire camera rotates on an axis and completes a transverse sweep. The camera has been used successfully in the air. The 48-inch is a vertical installation, making use of a scanning prism that can be at the bottom of the compartment. The size and cost of the 48-inch panoramic cameras has tended to make the panoramic camera an unpopular type, whereas a 36-inch panoramic camera would be far smaller and hardly any larger than the existing K-40 camera.

A 24-inch panoramic camera of another form is being studied, so that we shall shortly have three types. Before constructing additional 48-inch cameras, it will be well to consider a 36-inch camera for 1000 feet of 9-1/2 inch film. The 24-inch panoramic camera makes use of a scanning mirror. The resulting camera cannot include the horizon on either side in its sweep unless the camera is either close to the floor of the compartment or unless large enough windows are provided.

The film consumption of panoramic cameras is very considerable, a fact that puts a burden on the power needed, weight of film, and size of equipment. The existing 48-inch panoramic camera uses 5000 feet of film 18-1/2 inches wide. The result is a spectacular but too-bulky camera installation costing a great deal of money and usable only in the RB-36. It would be more practical to confine panoramic cameras to the range of focal lengths from 6 inches to 36 inches and to use not more than 1000 feet of film 9-1/2 inches wide. By special emphasis on weight and size reduction, one can design a quite compact panoramic camera with a lens of 36-inch focal length.

It is suggested that, after the possibilities of the 24-inch panoramic camera

~~CONFIDENTIAL~~



~~CONFIDENTIAL~~ ~~SECRET~~

have been studied, an evaluation of competing panoramic camera systems should be made and a course of action determined. If the panoramic camera is to be used, steps should be taken immediately thereafter to develop the most useful rectifying apparatus.

4. Strip Cameras

There exists a wide difference of opinion over the utility of the strip camera in aerial photography. The arguments pro and con are as follows.

Pro:

(1) Electronic synchronization of film speed with image speed permits the strip camera to be used successfully even in supersonic airplanes and at very low altitudes, where even with the usual jet fighter the image speed is high.

(2) The strip camera builds up its picture in one direction by parallel perspective. The camera can therefore "look down streets" in side views and verticals, whereas a point-perspective photograph of ordinary cameras causes buildings to hide the streets.

(3) Stereo-strip pictures in color at low altitude reveal excellent ground detail. One can even see spokes in bicycle wheels from 200 feet altitude at a speed of 400 mph.

(4) Projection of stereo-strip pictures reproduces the feeling of "flying" very realistically as the picture is moved slowly across the screen. One gets views even down inside bombed-out shells of buildings.

(5) Because of good image synchronization, longer exposures can be made on very poor photographic days.

(6) The strip camera is the only device we have at present for low-altitude use in jet planes.

Con:

(1) The strip camera does not stand alone for photography from fast airplanes. Once we have developed the fast-cycling 70-mm camera, or the 5-inch film camera described in Chapter 5, we shall be able to use these in the fastest airplanes at any altitudes, and hence can compete on even terms with the strip camera.

(2) The strip camera cannot take forward obliques (dicing) whereas a fast-cycling 70-mm camera can be used very successfully in this way.

(3) The strip camera shows a progressive deterioration with altitude, owing to the random traverse of the line of sight on the ground as caused by roll, pitch and yaw of the plane. Another way of describing the problem is to say that the scale becomes smaller at the higher altitude for the same degree of roll, pitch and yaw.

(4) The existing strip cameras do not have the slits close enough to the film for high-altitude use. Therefore, the motion-stopping ability of a given photographic exposure time is made worse through inefficiency of the slit shutter.

~~CONFIDENTIAL~~

~~SECRET~~

~~SECRET~~  
CONFIDENTIAL

(5) The strip camera cannot be used for purposes of measurement along the line of flight to a desired degree of precision. In vertical use, one cannot know with accuracy what plane movements have been superimposed on the picture. In oblique use, a time-consuming process of reduction is required, and even then the calibration is not exact. The strip camera can be used for measurements of heights of buildings, sea walls, etc., in side obliques.

(6) In a strip camera, film synchronization is possible for side obliques only for a chosen direction, say, the optical axis. Therefore, near objects are compressed along the line of flight and distant objects are stretched along the line of flight. This distortion is objectionable. If the slits are narrow and the disparity in distance not too great, there is danger that a photo-interpreter will be misled into furnishing measurements that seem to be correct but actually are not.

(7) In side obliques the stereo view is distorted. Some of this distortion can be eliminated in practice by tilting the slits. However, the tilt of the slits must be varied according to the oblique angle, and for the vertical the slits must become parallel straight lines.

(8) "Looking down streets" cannot be accomplished if the plane happens to be flying at a 45-degree angle to the streets. European cities are not likely to be laid out in rectangular patterns for controlled flying.

(9) High-altitude photographs made with long focal length lenses in stereo can also look down into streets and into bombed-out buildings. Therefore, the strip camera fulfills no need that cannot ultimately be taken care of by ordinary cameras, once the 70-mm camera or equivalent has become available.

(10) The present strip cameras are useful only for daytime reconnaissance.

The strip camera fulfills a need for low-altitude daytime sweeps in jet fighters, and is the only camera we have at present for successful use under these conditions. Its continued use is indicated until the 70-mm fast-cycling camera or equivalent has been service tested and proved satisfactory. Thereafter, it may be possible to use the 70-mm camera for all normal low-altitude photography, and to reserve the strip cameras for special missions carried out by specialized reconnaissance units.

## B. OPERATIONS

### 1. Peripheral Missions

The most important photographic means available to us on a pre-D-Day basis is one of peripheral or border photography from non-enemy territory or off the coasts of the Soviet Union and China.

~~SECRET~~  
CONFIDENTIAL

~~CONFIDENTIAL~~

High Obliques: 6-10 Miles Altitude

Although long-range oblique photography accomplished to date is spectacular, it is not the perfection of the photography but the intriguing character of high obliques that causes the pictures to be considered successful. From a photographic point of view, the photographs shown the Study Group are substandard in quality and well below what can be obtained by equipment of better design for the purpose, and used by personnel trained to know the internal troubles of optical systems. To a large extent, the 100-inch  $f/10$  folded camera with 9 x 18 format has been used; however, this camera was designed primarily for vertical photography and is structurally weak in the position used for oblique work. Also, the two mirrors are a possible source of trouble and, if improperly used, may affect picture quality. There are considerable changes in focus (due to temperature, altitude, and temperature gradients) that must be evaluated and compensated. The camera has no image-motion compensation, which for high oblique work is not too vital, and is not mounted adequately against vibration. The result is that the average photographs resolve only 3 or 4 lines/mm and the contrast is very poor. We are told that, when a trained photographer operated one of these cameras, the resolving power went up to 6 or 7 lines/mm. In the laboratory, the same equipment resolved 45 lines/mm over the entire format for each of the six lenses.

We have made no effort as yet to realize the possibilities of peripheral photography. By using high altitudes and remaining somewhat out to sea, we can choose the best photographic weather and the best lie of the sun with respect to Soviet territory. The flights must be planned to achieve the very best contrast in the distant details. This contrast depends critically on choosing clear weather free of ground haze, and the proper picture time relative to the sun.

Long-Range Obliques: 10-45 Miles Altitude

Most of the atmospheric haze on good photographic days is confined to altitudes below 10,000 feet. The basic atmosphere free of water vapor and dust is quite satisfactorily transparent to red and infrared light, as is well known in desert regions of the world. Nevertheless, such scattering as is produced in the pure atmosphere on good days above 10,000 feet is hardly any more pronounced at 45 miles altitude than at 7 miles.

It seems that our highest-altitude photographs may eventually be made in unpowered portions of the flight of a rocket or rocket-type vehicle. If balloons are used, there will similarly be no power to introduce vibration. Under these circumstances, we can expect our extreme peripheral obliques to be more or less free of vibration problems, and can expect our photographic performance to be better than average. It is not unreasonable, therefore, to expect a performance in excess of 15 lines/mm from 45 miles altitude, provided we have proper focus and a shutter fast enough to stop random motions. It is important that the shutter does not cause vibration or recoil of the camera. Assuming that we have good weather and that the personnel handling the photographic installation have adequate testing equipment at hand and are trained for the purpose, an average quality of 20 lines/mm should be our norm.

Thus, if we revise our thinking to include extreme-altitude obliques, we find that we can see far into the Soviet Union without violating frontiers. Furthermore, the rocket-type vehicles required could fly farther from the border and would probably be more difficult

~~CONFIDENTIAL~~

~~CONFIDENTIAL~~

for the Soviet Union to find and intercept.

Figure C-1 of Appendix C demonstrates that choice of a good photographic day makes a great deal of difference in the amount of interpretable detail obtained at a given large focal length. If the weather is of excellent quality, we can look twice or three times as far into the U.S.S.R. as on a bad day. The weather must be good over the entire area to be photographed, with the severest requirements given to atmospheric layers near the limit of the oblique, say at a 5-degree slope angle of the line of sight to the ground at the target area.

The vehicular problem, which is at the core of peripheral missions, is discussed in detail in Chapter 11. At the present time, we have the X-1 with a ceiling of 20 miles or so, and shortly may have the X-2 in use at ceilings up to 45 miles. Currently, there is no suitable camera equipment for the X-2 for the long-range high oblique missions. The danger is that short focal length cameras will be used because of the natural need for smallness, whereas long focal length equipment of light weight and compactness can and should be developed. The extreme value of the high-altitude long-range oblique should not be sold short because there is apparently room for only short focal length equipment. Suitable equipment should be designed in which long focal length is combined with smallness. This camera should have a focal length of 100 inches at f/10, should not weigh more than 60 pounds, and should not be larger than 22 x 22 x 15 inches. The pilot should be able to direct the oblique camera toward any clear area in the distance he may wish to photograph. The camera should be fast-cycling to permit a maximum number of pictures in the time of flight. If we combine excellent weather with precision-quality long focus lenses, and take pictures from very high altitudes, we have a capability for looking hundreds of miles into the U.S.S.R. without violating Soviet airspace.

Thus, if we were to use a rocket plane such as the X-2 up to 45 miles altitude we might photograph 300 miles into Russia. With a very compact 100-inch fast cycling spotting camera we could take pictures showing details as small as 100 feet on a side resolved at this limiting distance of 300 miles. We could recognize details approximately 400 feet on a side. Contrast gradations would permit study of crops, forests, roads, and the like. Rivers and lakes would not only be recognizable but could be charted quite accurately.

The Study Group has been shown a winter-time scene in a vertical picture made from 90,000 feet altitude showing railroad beds and highways with the taking lens having a focal length of only 44 mm. This is a distance of 17 miles. If we wish to obtain the same details at 300 miles, we have a factor of 17.6 transversely which applied to 44 mm yields a focal length of only 30.5 inches. Thus, if we use a 36-inch lens on a good day with snow cover, we could expect to see rail beds, towns, roads and other such details 300 miles inside the U.S.S.R. The development of the X-2 airplane indicates that the means for such operations may be close at hand. A very light-weight 36-inch camera can be built for the job.

Long-Range Panoramic Obliques: 45-250 Miles Altitude

If we further revise our thinking to include still greater altitudes than those discussed above, the possibilities become even more spectacular. The WAC CORPORAL as a second-stage rocket has been up to 250 miles. With a larger rocket at 200 miles, carrying a light-weight camera, with lens of long focal length, we can think of photographing 1000 miles into the U.S.S.R. (see Table 6-1). The haze problem will not be significantly worse. At

~~CONFIDENTIAL~~

~~CONFIDENTIAL~~

~~SECRET~~

1000 miles, a 100-inch focal length can potentially show airfields, towns, rivers, crops, forests, and the like.

Let us consider the physical conditions at a point 250 miles above the earth's surface. Practically all the atmosphere lies below this point. The horizon lies at an angle of depression from a horizontal plane of about 20 degrees, owing to the spherical shape of the earth. Above this horizon, the sky will be dark enough to show the brighter stars, even though the sun is well above the horizon. The atmosphere and earth's surface below the horizon will be brightly illuminated all the way from the darkish areas of the ocean to the white surface of extensive cloud layers. Where there are no clouds, indicating clear weather over the area, the earth's surface will show darkish and hazy coloration, varying from the greens of forests and crops to the brownish reds of the deserts, all the colors being washed out and left unsaturated by the overlying bluish atmosphere. Visually, the contrast will be poor except for ground areas directly below. In infrared light, however, the contrast will be much improved. The basic atmospheric Rayleigh scattering will be penetrated by the infrared light rather well, even for light leaving the ground at the target area at a 5-degree slope angle to the tangent plane. In Table 6-1, the target area is calculated to lie at such a distance from the rocket that the line of sight actually does have a 5-degree slope angle with the tangent plane. Photographs at hand indicate that on good days, even at such a low angle, there remains much interpretable detail.

Table 6-1 presents the results of calculations made from Fig. 6-1. We see that, at an altitude of 160.0 miles, we can penetrate a distance of 816.1 miles along the ground from the rocket takeoff point before the line of sight reaches the 5-degree limiting angle with the tangent plane at the target area. To preserve approximately the same photographic scale as the revealing pictures taken by E. P. Ney (at the University of Minnesota) from 17 miles with a 44-mm lens (see Fig. 6-4), we have only to provide a focal length of 77 inches. This appears quite feasible if optical techniques are adequately exploited.

One of the most promising techniques appears to be a fuller exploitation of vertical rockets. We visualize simply a rocket-camera combination, as elementary in character as will do the job. The rocket will serve essentially as a motor to drive the camera to as high an altitude as possible. The camera is to be a one-picture affair, consisting of an optical arrangement of panoramic type but nonsweeping. The picture is to be on a single piece of film where the whole solid angle beneath the rocket has been turned into an annular area on the film. By employing distortion, one can use an equivalent focal length of perhaps 100 inches in the areas near the horizon varying down to perhaps 50 inches at 45 degrees off the vertical. In this way a relatively small picture can be obtained and a long focal length retained where scale is needed. The camera should take in the entire horizon by means of a single shutter movement, spring-operated. One needs only to have some means, such as rocket spin, for the rocket to preserve a vertical axis up to picture time. The peculiar pictures that are obtained can be reduced by mapping methods into the usual charts, and can be used for reconnaissance purposes. Weather observations will be a byproduct because such pictures will contain perhaps a million square miles, only a portion of which may be clear.

There are distinct possibilities for a panoramic-type camera employing a single sweep, spring-driven. The rocket may be spinning to preserve a vertical axis, with the

~~CONFIDENTIAL~~

~~SECRET~~

~~SECRET~~  
~~CONFIDENTIAL~~

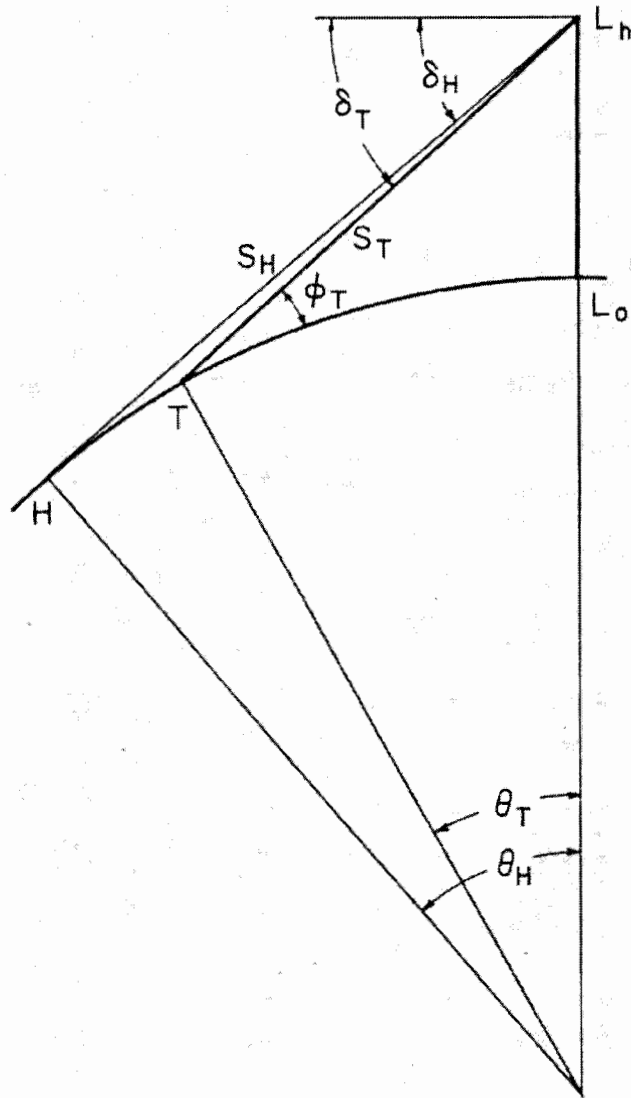

Fig. 6-1. The basic geometry of long-range oblique photography, as shown in meridional section.

~~SECRET~~  
~~CONFIDENTIAL~~

CONFIDENTIAL

CONFIDENTIAL

TABLE 6 - 1

ALTITUDE-DISTANCE RELATIONSHIPS FOR LONG-RANGE OBLIQUES  
(the earth's curvature is taken into account)

Altitude	Focal Length for Constant Scale	Horizon Distance Along Ground	Horizon Distance Along Line of Sight	Angle of Depression of Horizon	Target Distance Along Ground	Target Distance Along Line of Sight	Angle of Depression of Target
h (miles)	f (inches)	$R\theta_H$ (miles)	$S_H$ (miles)	$\delta_H$ (degrees)	$R\theta_T$ (miles)	$S_T$ (miles)	$\delta_T$ (degrees)
2.5	2.52	141.5	141.5	2.0	27.5	27.6	5.4
5.0	4.86	199.9	200.1	2.9	53.1	53.3	5.8
10.0	9.2	282.6	283.0	4.0	90.9	100.5	6.4
20.0	16.6	399.2	400.5	5.7	180.8	182.4	7.6
40.0	26.9	563.3	567.1	8.1	313.1	317.1	9.5
80.0	48.1	793.4	804.0	11.4	516.9	527.7	12.4
160.0	77.1	1113.0	1142.6	15.9	816.1	846.0	16.7
320.0	120.3	1540.3	1631.7	22.2	1237.1	1319.9	22.7
640.0	185.0	2125.8	2351.5	30.5	1802.5	2028.6	30.8
1280.0	284.0	2844.8	3446.5	40.8	2513.4	3115.5	41.0
2560.0	443.3	3660.2	5199.4	52.4	3322.8	4862.5	52.6

- h = altitude of rocket in miles to peak at  $L_h$
- f = focal length of lens required to give same scale as on balloon pictures shown by Ney with 44-mm lens
- R = radius of earth, adopted as 4000 miles
- $\theta_H$  = angle at center of earth between horizon point of tangency and rocket takeoff point,  $L_o$
- $S_H$  = distance from peak rocket altitude  $L_h$  along line of sight to horizon point of tangency, H
- $\delta_H$  = angle of depression of H as seen from  $L_h$
- $\theta_T$  = angle at center of earth between target point T and  $L_o$
- $S_T$  = distance along line of sight from  $L_h$  to T
- $\phi_T$  = slope angle of line of sight to tangent plane at T, adopted here as 5 degrees to go with photographs at hand showing interpretable detail at this limiting angle
- $\delta_T$  = angle of depression of T as seen from  $L_h$

single photograph made near peak altitude, gauged by a timing device. Just prior to picture taking, the film is made stationary in space by the inertial properties of a transitory, spring-driven gyroscope. Gyro precession can even prepare the camera for the picture.

If these techniques can be worked out on a sufficiently inexpensive basis, we have a means for maintaining a kind of patrol of Soviet areas. Perhaps there could be a number of well-located stations, such as in northern Japan, South Korea, Formosa, Turkey, Greece, Yugoslavia, West Germany, and the like, where rockets are sent up at frequent intervals. One advantage of the high-altitude peripheral approach for pre-D-Day surveillance deep into the U.S.S.R. is that we can choose days when the weather near the border on either side is very bad, but when the weather beyond is good for photography. The rocket vehicle can go up through this bad weather and look into clear areas far away in the Soviet Union. Figure 6-2 illustrates the technique.

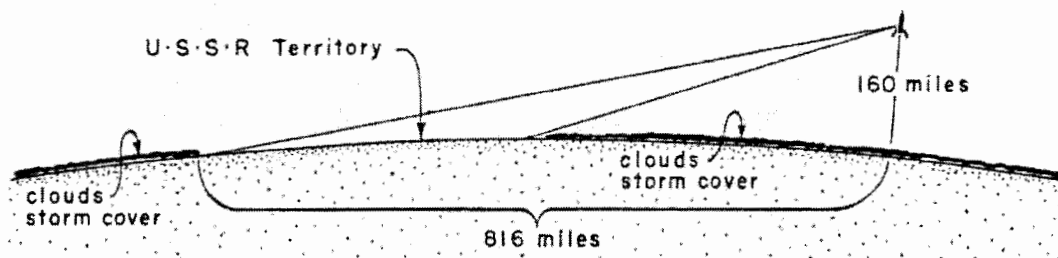

Fig. 6-2. A schematic representation of the long-range oblique from altitudes obtainable with rocket-camera combinations.

The photographic equipment needed for the long-range oblique from high altitudes, the installation problem, the planning and the carrying out of the missions should all be handled by special reconnaissance units such as are described in Chapter 12. In any case, a high level of technical results must be attained on these special reconnaissance missions. Poor photographic results need not be tolerated in view of what is now feasible.

By the fullest exploitation of rocket vehicles, camera equipment and weather, we can create a pre-D-Day capability that will enable us to photograph large portions of the Soviet Union and China without violating their airspace.

## 2. Penetration Missions

Two types of vehicles for possible pre-D-Day penetration missions are given particular emphasis in Chapter 11: high-altitude balloons and guided missiles of the RB-62 (SNARK) type. The views of the BEACON HILL Study Group on the relative merits of these systems are stated in Chapter 11.

With high-altitude balloons, it has already been demonstrated that even lenses of short focal length can return valuable information from 17 miles altitude (see Figs. 6-3, 6-4,



~~CONFIDENTIAL~~

~~SECRET~~

and 6-4). Pictures taken from 18 miles (95,000 feet) with a 36-inch focal length lens are of first quality and reveal a tremendous amount of detail (see Fig. 6-5). Power and duration are both factors to be considered. A single storage battery weighing 30 pounds at a 200 ampere-hour rating can cycle a 36-inch camera for as long as the film holds out, the latter having a practical quantitative limit too. A panoramic camera requires much more power, and a study would have to be made to determine how much is needed. It should be possible to employ a 24-inch focal length, compactly designed panoramic camera, using 9 1/2-inch film 1000 feet long, which together with the power plant would weigh less than 300 pounds. From 18 miles altitude from balloons, one can obtain 160 photographic strips 300 miles by 6.7 miles with a large amount of interpretable detail.

The camera problems for SNARK are similar to those discussed in Chapter 5 for high-altitude photography from manned aircraft. The emphasis should be on compact camera designs with focal lengths up to 36 inches.

~~CONFIDENTIAL~~

~~SECRET~~

~~CONFIDENTIAL~~

Fig. 6-3. A contact print of a picture taken from 90,500 feet with a 6-inch Metrogon wide-angle lens and yellow filter. The atmospheric conditions were good but far from excellent. Later pictures in the balloon flight show extensive cumulus clouds. The target point where the line of sight makes a 5-degree slope angle with the tangent plane is approximately 0.2 inch below the horizon line. The curvature of the earth is clearly shown. The picture is by no means top quality, owing to imperfect weather, use of a yellow filter and Super-XX instead of a red or infrared filter-emulsion combination, and to insufficient scale. Table 6-1 recommends use of at least a 16-inch focal length lens in the direction of the target point instead of a 6-inch. As discussed elsewhere in this Report, focal length is of prime importance for penetrating the horizon haze.

~~CONFIDENTIAL~~



CONFIDENTIAL

~~CONFIDENTIAL~~

Fig. 6-4. The picture is an enlargement of a negative taken with a 44-mm focal length lens from a balloon at 80,000 feet in the wintertime. The scale of the original negative is 1:600,000.

~~CONFIDENTIAL~~

**CONFIDENTIAL**

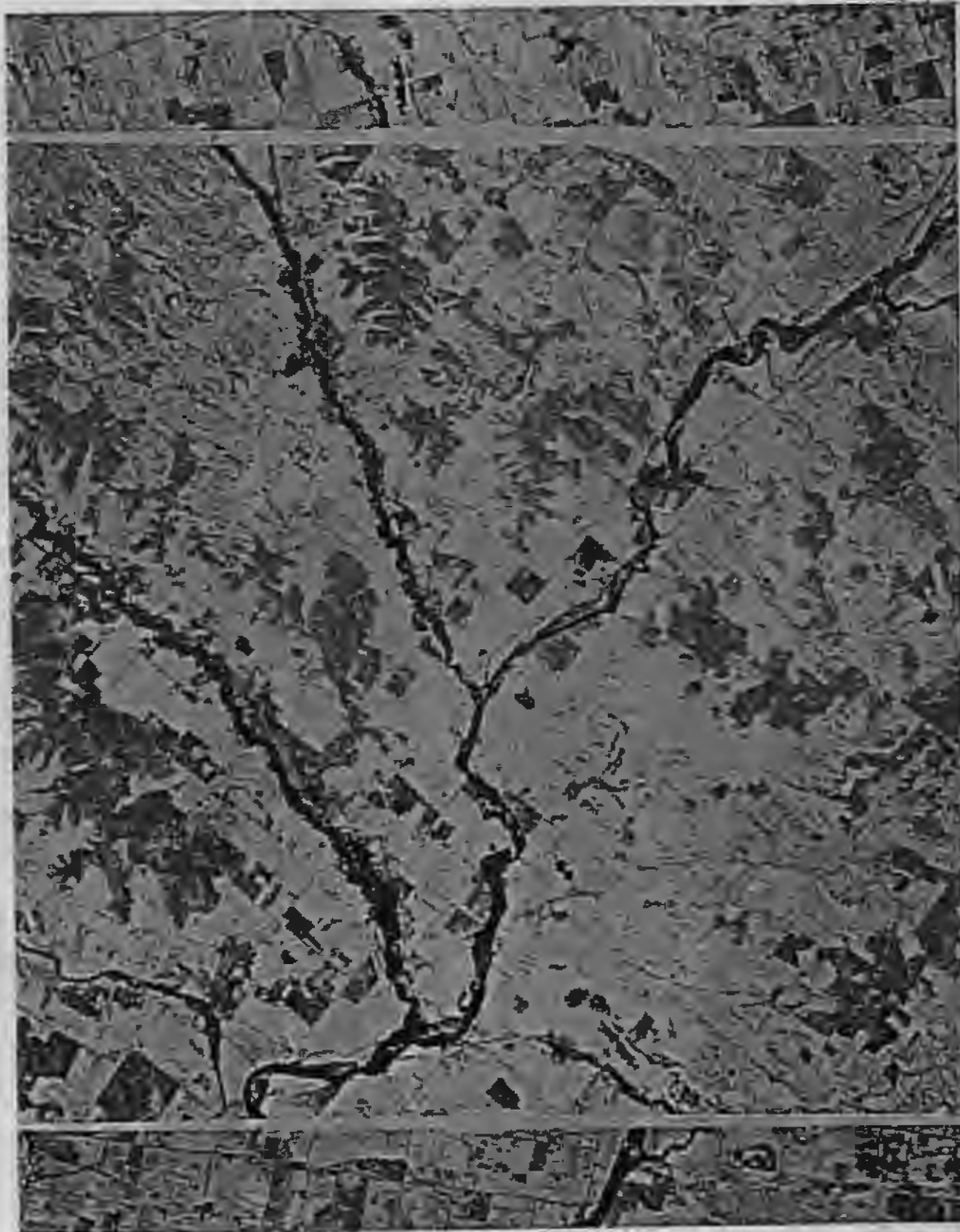

**CONFIDENTIAL**

~~CONFIDENTIAL~~

Fig. 6-5. The picture is an enlargement of a negative taken with a 1-1/2-inch focal length lens from a balloon at 70,000 feet in the summer-time. The photograph shows much interpretable detail at an original scale of 1:560,000. The minimum scale proposed in Table 6-1 is 1:600,000 at the 5-degree slope angle and limiting target point in the transverse direction to the line of sight.

~~CONFIDENTIAL~~

~~SECRET~~  
~~CONFIDENTIAL~~



~~CONFIDENTIAL~~

~~SECRET~~

**CONFIDENTIAL**

Fig. 6-6. This picture was taken on the same flight as the photograph of Fig. 6-5. but with a 3-inch taking lens. The original scale approximates 1:280,000.

**CONFIDENTIAL**

**SECRET**



CONFIDENTIAL

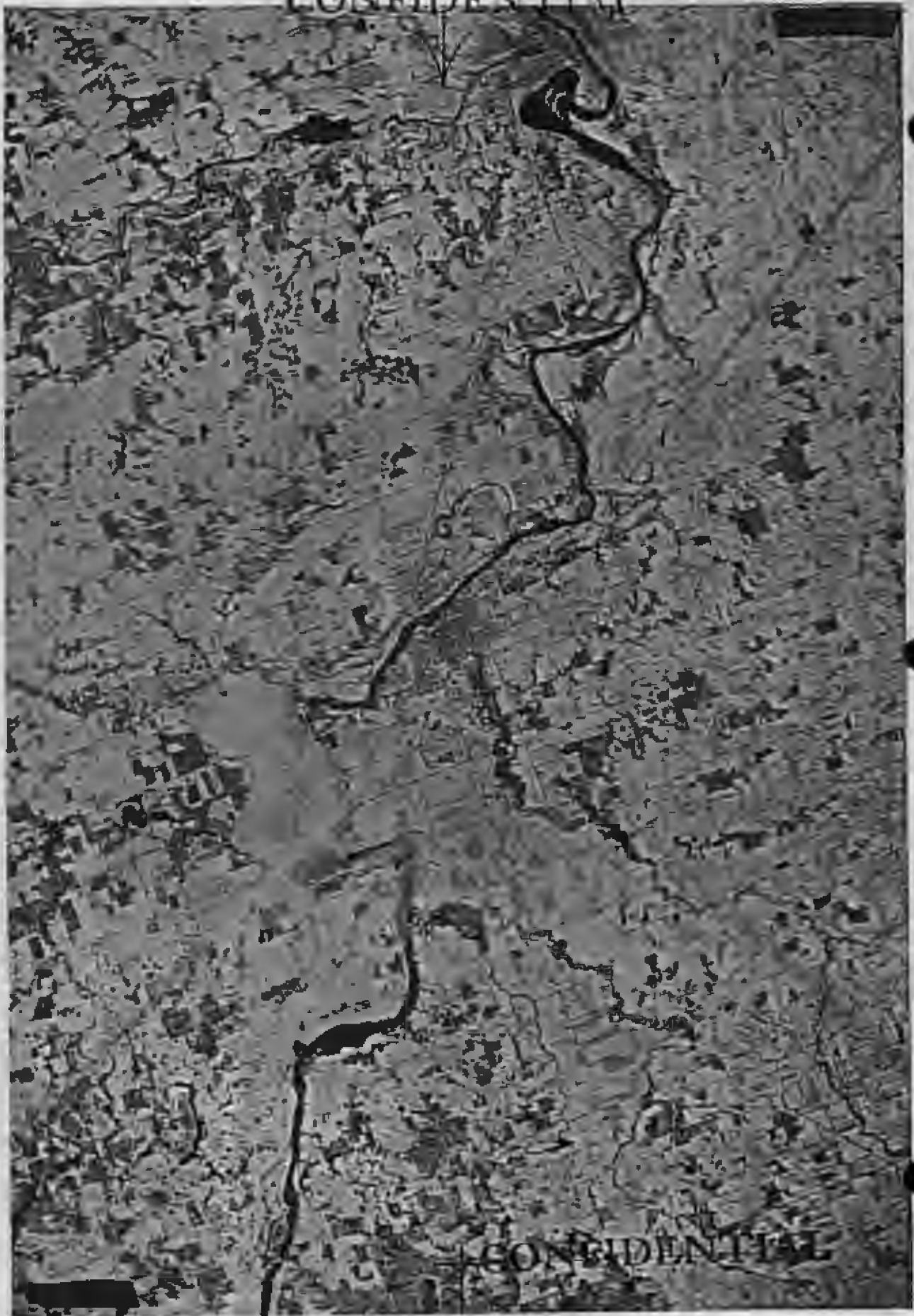

CONFIDENTIAL

~~CONFIDENTIAL~~

~~SECRET~~

Fig. 6-7. A 2X enlargement of a portion of a 9x18-inch vertical photograph made from a balloon at 95,000 feet with a 36-inch  $f/8$  telephoto. A yellow filter was used. The exposure time was approximately  $1/125$ -th of a second. The photograph is of high quality and demonstrates how little haze there is on an excellent photographic day. The scale is 1:32,000.

~~CONFIDENTIAL~~

~~SECRET~~



CONFIDENTIAL

~~SECRET~~  
~~CONFIDENTIAL~~

CHAPTER 7

A NEW APPROACH TO PHOTOGRAPHIC RECONNAISSANCE

Aerial photography presents two great problems. The first is that the ground as seen through 10,000 feet of hazy air presents a range of brightness of only five to one on good days and of less than two to one on poor (but not bad) days. Because photographic emulsions are really layers of pigment, fine lines with small contrast between them are blurred out at the time of image formation by scattering in the emulsion. Hence, resolving power from the air, for targets on the ground, drops from the 40- to 100-line range that we achieve in photography in our everyday life to a 3- to 14-line range from the air.

The second problem in aerial photography is that the image slides around on the film during exposure - slides in one direction because the airplane is moving, and slides in all directions because the optical axis of the camera vibrates within a seriously large angled cone - thus pointing the camera to a variety of slightly different places during the time of exposure. It is intuitively obvious that even without the haze, and even with a photographic film that did not scatter light, this angular vibration of the camera would be objectionable. But it is almost disastrous when compounded with these other difficulties, because the already-low contrast is diminished still further, leaving it possible to resolve so few lines per millimeter that the whole camera must be large to provide a big picture, with detail gross enough to be recorded. And now the vicious circle closes, because the big camera demands big mechanisms to stop the image from sliding around. These are as yet unavailable or not in use, so the resolving power goes down - and the camera size, in an inflationary sort of way, goes up once again.

How can this trend be countered? There is one happy combination of opportunities. If it were possible to use a small camera, it could be mounted with its center of gravity at the center of a gyroscopic system (or the equivalent, which we shall discuss later). It is interesting to consider the advantage of the integral system, that is thus made possible, over so-called stabilized platforms. These involve gyroscopes and servo systems that are characterized by associated oscillatory motions, whereas the small camera integrally stabilized is free from these minute but optically dangerous excursions. Now, if we do succeed in freeing the camera from all angular vibration, and if we use the same stabilizing mechanism to rotate the optic axis for image-motion compensation, then we should be able to bring at least a 50-line-per-millimeter image to the film.

The problem then would be to obtain an emulsion competent to resolve such a fine image at the low contrasts that must prevail because of aerial haze. Such emulsions would be fine-grained, contrasty, and somewhat slow. The slight slowness however is not an obstacle, since the stabilized image in this camera makes possible longer exposures. Thus we see that the small camera makes possible a stable image, the stable image makes feasible a small film, a small film makes possible a small camera, and a small camera can be stabilized.

In the course of reviewing photography as it is now known or contemplated in the Air Force, we came to visualize this new, systematic approach, extending from the emulsion manufacturer to the photographic interpreter. This approach, which we have designated as the "Reconograph System," unifies in two or three relatively small "black boxes" the

~~CONFIDENTIAL~~

~~CONFIDENTIAL~~

handling of all tasks in aerial photography.

Box I

Box I, which is primarily the camera placed over a window in an airplane, is designed to solve within itself all its own problems: antivibration mounting, image-motion compensation, exposure control, orientation, and programing. The box is small enough to go in a fighter, and makes no "systems" demand on the plane other than volumetric.

Box II

Box II performs the total processing operation. It derives its compactness and automaticity from three proposals:

- (a) The Reconograph can make feasible good photography at high altitudes (30,000 feet) with film as small as 35 to 70 mm.
- (b) Processing is accomplished by one of the new instantaneous techniques.
- (c) The image is viewed (in Box III) through a magnifying binocular as a transparency, the transparency being either a negative developed for high contrast and for being viewed directly, or a positive made by reversal.

As compared with the elaborate installations required today, Box II is spectacularly compact. Indeed it is expected that in the near future Box II may become so compact as to make the processing step an almost spontaneous transition from exposed film to film ready for observation.

Box III

Box III is the viewing station. It involves as its primary optical mechanism a binocular microscope of variable magnification. The film on the reel - exposed in Box I, processed in Box II - feeds into Box III where the stereoscopic pairs may be examined with magnifications as low as 2 times and as high as 30. Here one of the dominant principles of the Reconograph System becomes apparent, namely, that the image to be examined should be in as primitive form as possible. Every departure from this primitive record undertaken for aesthetic reasons - such as choosing to use a positive rather than a negative - must be justified by careful comparison of what is gained aesthetically with what must be lost from the initial information content.

Box III may be elaborated. By using a sequence of viewing stations, a group of specialists in different aspects of interpretation can work at the same table on the same reel of film. A projection printer for projecting an enlarged picture on to standard photographic paper for subsequent development and distribution can be so built that the observer using the microscope can decide what frames and what portions of frames he wishes recorded; by depressing an indicator he can have these records made without pausing in his continued observation of the reel.

Of course, many of the purposes of the Reconograph System have been considered in the past. When examined one by one, they seem to lack novelty, and many of them have a history of impracticability. We shall try to show here that, by aggregating all the good purposes and by undertaking in a determined way to solve at one and the same time all the problems of making photography an elegant and compact tool of reconnaissance, the problems are simplified and the impracticability eliminated.

~~CONFIDENTIAL~~

~~SECRET~~

~~SECRET~~  
~~CONFIDENTIAL~~

Let us proceed to the study of the heart of Box I. We have already indicated that the format is small. The lenses range in focal length from 2 inches to a 12-inch telephoto. The film frame, where the image is formed, and the lenses are mounted rigidly together, and this rigid mount has its center of gravity at the center of double gimbals. From the film frame to the reels the film travels in opaque, flat, flexible tubing. The position of the gimbals and their rate of change of orientation is determined by special "motors" on the appropriate axes of the gimbals.

We have seen that one of the most serious sources of degradation of quality in aerial photography is vibration, but what must be emphasized is that it is not the translational components of the vibration but the rotatory that are damaging. We have also seen that the other important source of degradation at the time of image formation is the sliding of the optical image across the film because of the progress of the airplane. Both these sources of degradation can be eliminated by the gimbals mounting and the associated motors. When they are eliminated, fast shutters and - what is more important - fast film become unnecessary. It is in this way that an opportunity is created to select emulsions and to create new emulsions designed particularly for high resolution even when the target manifests low optical contrast.

The motors provide the controllable restoring torque and damping in the mechanical linkage between the camera and airplane. At the same time, they provide a means for sensing relative angular position on the basis of which the appropriate restoring and damping torques are electronically controlled. A third function of the motors is to provide a controlled angular impulse just prior to exposure to effect the required image-motion compensation. In effect, the motors are a pair of hands connected to a rudimentary brain and are able to provide a position control that is at all times appropriate to the function.

It is the ability of Box I to bring a perfectly stabilized image to the emulsion that is the first basis for our hope of a revolutionary simplification of aerial photography. The existence of an apparatus that will take advantage of every improvement in resolving power and sharpness, and at the same time permit the use of slower emulsions, will be a most powerful stimulant to the development of films capable of exploiting all the virtues of such a system. Indeed, it appears that films do exist now that would be satisfactory. Preliminary observations that we have made during the course of this study indicate that some of the fine-grain, high-contrast emulsions now available, if used in Box I, and correctly exposed, would provide stereoscopic pairs in the form of negative transparencies that are amazingly rich in reconnaissance information and can be profitably viewed in a high-magnification (20x) binocular microscope.

In summary, then, from an apparatus point of view, the Reconograph System would use 35- to 70-mm film, 2- to 12-inch focal length lenses, a camera stabilized for rotatory vibrations with image-motion compensation deriving from the stabilizing system. It would feed the film continuously through a processor that would instantaneously convert it to a contrasty transparency which would be viewed as such in the variable-magnification stereoscopic microscope.

~~CONFIDENTIAL~~

~~SECRET~~

~~CONFIDENTIAL~~

~~SECRET~~

We recommend the development of the Reconograph System as a means of providing for aerial photography a systematic approach extending from emulsion manufacture to the photo-interpreter.

~~CONFIDENTIAL~~

~~SECRET~~

~~CONFIDENTIAL~~

CHAPTER 8  
PHOTOELECTRIC AIDS TO RECONNAISSANCE

A. INTRODUCTION

The adaptation of certain proven photoelectric techniques to reconnaissance missions can, we believe, be of great use in picking up and transmitting information from an airborne vehicle to another aircraft or to the ground. At the present time, reconnaissance aircraft must deliver film by landing at a base or dropping a container of film by parachute; the film must then be processed, prints must be made, and these must be sent to the appropriate destination by carrier or by facsimile transmission similar to that used for newspaper photography (this latter technique is in an experimental evaluation stage at SAC). The limitations of present procedures as they affect combat capabilities are:

(1) The reconnaissance aircraft may be lost to enemy action and hence not return to base; thus, no advantage can be derived from any information it has secured.

(2) There is a long time lag if, after the photographic intelligence is processed, the courier aircraft has to make a long flight, or if weather conditions delay takeoff.

Both limitations can be overcome by application of photoelectric techniques. In addition, certain advantages, other than speed and insurance against loss, can be derived from use of the proposed procedures.

We shall discuss here only the use of well-known methods in conjunction with equipment and components already in existence (or essentially ready for use). The methods we propose are neither television nor facsimile as these are currently known, but are custom-tailored to reconnaissance needs. By their use, information could be obtained from an aircraft in flight in a fraction of the time now required for the vehicle to return to base, land, and deliver the results of its mission. Photoelectric techniques could be utilized in several ways:

(1) Direct photoelectric pickup, enabling a distant receiving station to "see" on a screen the same terrain aspects observed by the reconnaissance aircraft.

(2) Transmission of visual photographs to another aircraft or to a ground station

(3) Transmission of radar-scope photographs to another aircraft or to a ground station.

We shall recommend that each of these methods be developed experimentally and evaluated for use in reconnaissance missions.

B. INSTANTANEOUS IMAGE VIEWING

The advantages of instantaneous pickup and transmission of visual images are numerous. Some of the more important ones are:

(1) The shortest possible delay between observation and interpretation;

(2) Great light sensitivity;

~~CONFIDENTIAL~~

~~SECRET~~



~~CONFIDENTIAL~~

~~SECRET~~

(3) An electronic link within the plane permits observation of the ground by the pilot in flight.

Instantaneous image viewing lends itself particularly to use by low-flying fighter aircraft as a means of quickly obtaining information on targets of opportunity. Also, if the aircraft fails to return from the mission, a record of the terrain surveyed will have been made at a distant safe point.

When short-range expendable terminal missiles become available, the instantaneous image pickup and transmission system will permit pre- or post-strike observations to be made of heavily defended areas from relatively safe distances.

In order to illustrate the possibilities of instantaneous image viewing, a specific system will be suggested here for reconnaissance missions when weather conditions make it necessary that the aircraft fly at low altitudes (around 2000 feet).

Because of the great flying speeds involved, some form of image-motion compensation will be necessary. Therefore, scanning in the direction of travel of the aircraft will be carried out by the aircraft itself, while scanning at right angles to the motion of the aircraft will take place in the pickup device and will be referred to as line scanning.

Using a standard image orthicon camera tube, and with the aircraft at an altitude of 2000 feet, the maximum length of the scanning line that can be utilized in the image plane - that is, on the photo-cathode of the image orthicon tube itself - is about 2 inches. Hence, a lens with a focal length not much shorter than 2 inches is recommended. The 2-inch long scanning line on the image orthicon cathode will resolve approximately 1000 picture elements, which corresponds to 10 photographic lines per millimeter. The strip on the ground that will be imaged by the 2-inch lens will be 2000 feet wide and the minimum resolvable object dimension of the ground will be 4 feet (corresponding to one photographic line or two television lines).

If the same equipment were used in clear weather at an altitude of 20,000 feet, the system would cover a strip on the ground approximately 4 miles wide, and the minimum resolvable object dimension on the ground would be 40 feet.

The image motion in the plane of the pickup tube can be calculated as follows.

$$V = \frac{1.46 \times M \times F}{f}$$

where

V = image motion in camera plane (inches/second),

M = aircraft ground speed (mph),

F = focal length of optical system (inches),

f = aircraft height above ground (feet).

Thus, for instance, if the aircraft at 2000 feet altitude were flying at a speed of 700 miles per hour, the resultant image motion with a 2-inch focal length lens would be one inch per second. Since the resolution of the system is 500 lines per inch, the number of lines scanned per second is also 500 (for this particular ground speed). A picture 2 x 2 inches square

~~CONFIDENTIAL~~

~~SECRET~~

~~SECRET~~

~~CONFIDENTIAL~~

will be scanned in two seconds. The video bandwidth required is

$$\frac{500 \times 1000}{2} = 250 \text{ kc.}$$

If the aircraft were to travel at a ground speed of 1400 miles per hour, the line-scanning frequency would have to be 1000 per second if the full resolution of the system is to be realized. The required video bandwidth in that case would be 500 kc. It follows that, if wide variations are expected in the speed of the aircraft, the line-scanning rate should be variable, and provision should be made to handle the upper limit of the video bandwidth corresponding to the highest line-scanning rate to be employed.

The horizontal-scanning frequency can be obtained from the following expression

$$L = \frac{730 \times M \times F}{f}$$

where

L = line-scanning frequency (cycles per second),

M = aircraft ground speed (mph),

F = focal length of optical system (inches),

f = aircraft height above ground (feet).

The above assumes the resolution capability of the pickup tube to be 500 lines per inch. The video bandwidth can be calculated in cycles per second as

$$\frac{1000 \times LF}{2}$$

One advantage of using a standard image orthicon tube for this application is that high light sensitivities can be obtained by combining storage with electron multiplication. It is stated that the Boston University photoelectric scanner which uses the photomultiplier tube produces good pickups with a ground illumination of approximately 1.5 foot lamberts. The system suggested here will have even greater sensitivity.

In order to avoid burning-in of the scanning line on the image orthicon target, a slight vertical deflection at right angles to the direction of line scanning would be applied at a slow rate. Specifically, the height of this vertical scan would be approximately one-half inch, and the time required to move the line scan across this distance would be approximately 2 minutes. A sawtooth-shaped deflection current could be applied, provided the flyback time were fast enough; otherwise, a symmetrical sawtooth would be adequate. The slow vertical scan would result in spreading the electron beam over a larger area, equivalent to approximately 200 lines. This is known to prevent burning-in conditions. The extremely slow vertical scan will not cause a detectable image distortion.

It is important that, after each line scan, the target of the image orthicon be almost completely discharged so that no image information is carried over to the next line. Use of the image orthicon tube in color television has resulted in techniques by which this can be accomplished.

~~CONFIDENTIAL~~

115

~~SECRET~~

The output of the image orthicon camera would be amplified and combined with synchronizing signals. The latter would be normal line-synchronizing signals generated in routine fashion which would drive the line scanning and, at the same time, furnish synchronizing means for the remote receiver. Line-blanking signals to eliminate retrace will be generated too. The composite video and synchronizing signals modulate a transmitter. As stated earlier, the modulation bandwidth for the specific values chosen would be approximately 250 kc. The method of transmission will be dealt with later.

The equipment so far described employs existing and known techniques and components and could therefore be readily assembled and tried out. The operation is simple and the total space required would be small.

This equipment differs from that now under development at Boston University and at Haller, Raymond & Brown in that it attempts to meet the very much faster flying speeds proposed for future reconnaissance operations.

At the receiving point, which could be either in another aircraft or on the ground, four types of presentation or recording are possible.

Method 1: - The first method involves viewing the ground information as a sequence of stationary images. For this purpose, one or more cathode-ray picture tubes with long-persistence phosphors can be used. The line-scanning information would be applied to the horizontal scan which would be synchronized by means of the transmitted synchronizing pulses. The vertical-scanning frequency could be chosen more or less arbitrarily, depending on the extent to which the vertical scale (the scale in the direction of flight) is to be matched to the horizontal one. If, for instance, the aircraft at a ground speed of 700 miles per hour at 2000 feet and using a 2-inch lens were to transmit the picture information to a distant point where a vertical scan of once every two seconds is utilized, there would be produced on the picture tube an image where the scales in vertical and horizontal directions are equal. If the vertical scan were changed to once per second for the same image dimensions on the viewing tube, the vertical scale would be stretched in the ratio of 2 to 1 as compared with the horizontal scale.

Because the persistence of the phosphor screen may still be appreciable after one or two seconds, it may be desirable to use a bank of viewing tubes consisting of two, three or four units adjacent to each other, in order to permit reception of additional information without causing blurring and confusion. The video information is switched during successive frames from one picture tube to the other, thereby giving sufficient time for the screen to decay. Storage-type receiving tubes, if available and capable of halftone rendition with adequate detail, could also be employed for this purpose.

Method 2: - While it is of interest to produce fugitive images, which permits an observer in the plane or on the ground to follow the flight as it takes place, it would be of great value to produce a permanent record of the transmitted images. This could be accomplished in a number of ways. One method would be to modulate the beam of a flying-spot cathode-ray tube that scans in line direction

~~SECRET~~

~~CONFIDENTIAL~~

only and is synchronized with the line scanning in the aircraft where the pictures originate. This tube should be capable of at least 1000-line resolution across the entire screen diameter. This resolution can now be obtained with conventional 7-inch flying-spot scanning tubes, with an anode potential of 30 kv.

With a suitable optical system, the line scan is projected onto a moving sensitized film, which can be of the Land or the conventional type and in which accelerated processing could take place at high temperature. The velocity of the film again determines the vertical scale. In order to avoid burning-in of the single-line scan in the cathode-ray tube screen, a technique similar to the one employed at the pickup tube should be applied. A slow vertical scan will move the line scanning over an area of approximately one inch at such a slow rate (once per two minutes) that the change of scale would be imperceptible, yet the electron load would be distributed over an area large enough to assure sufficiently long screen life. The slow screen vertical motion at the receiving tube need not synchronize with that of the camera because of its extremely slight effect on the scale.

Method 3: - A third method of image presentation would be recording through the use of an optical scanner consisting of a rotating mirror polygon that deflects a light spot at line-repetition rate across the moving film to be exposed. The light source could be either a Philips-type gas discharge lamp or a suitable incandescent filament modulated by an ADP/30 cell. This type of modulator has been developed by Baird Associates, Cambridge, Massachusetts.

Method 4: - A fourth method of presentation of the picture information would be through use of magnetic tape. A tape moving at the speed of 100 inches per second can record frequencies up to about 200 kc per second. If the frequency spectrum is split into two halves through suitable beat-frequency methods, the picture signal can be recorded as a double track, each track having to handle a maximum frequency of 125 kc.

The possibility exists also of recording the entire spectrum by means of simultaneous modulation of a number of heads (about 3) and of using a coding method whereby only on and off information is fed to these heads. Eight possible combinations can be produced with 3 heads, which would correspond to 8 different intensity levels of the gray scale. The necessary signal-to-noise ratio with this type of recording would be quite low (approximately 6 db).

It was pointed out at the outset that instantaneous image viewing is most readily adaptable to low-flying aerial reconnaissance, and that the amount of area covered on the ground is relatively small. For such limited ground coverage, the resolution of the system will be adequate. If it is necessary to transmit more picture information with acceptable resolution, a facsimile-type system, as described in the following section, is suggested.

#### C. TRANSMISSION OF HIGH-RESOLUTION PHOTOGRAPHS

The data-transmission system envisaged for high-resolution photographs is, in effect, a fast facsimile method, capable of handling the bare minimum of photographic in-

~~CONFIDENTIAL~~

~~SECRET~~

~~CONFIDENTIAL SECRET~~

formation with a minimum of bandwidth and time. It is proposed that no more than 10 seconds be used for the transmission of each photograph and that the bandwidth requirement does not exceed 250 kc.

There will be 2300 scanning lines with the same number of elements per line. Thus a 9 x 9 negative can be transmitted with a resolution of 5 photographic lines per millimeter. If the contrast of the system is maintained throughout its ultimate resolution, the average aerial photograph in the field will not lose appreciably in quality. Electronic techniques for maintaining high contrast ratios in the finest detail of the photoelectric system are known and are available.

Incidentally, if the image to be transmitted is a 70-mm negative, the resolution of the transmission system will be equivalent to 17 photographic lines per millimeter.

The image pickup system could be arranged in a number of ways. For a 10-second transmission time, the line-scanning frequency is 230 per second. A rotating reflecting polygon system could be used with 15 reflecting surfaces rotating at 900 rpm. The vertical scanning motion would be carried out by the movement of the photograph itself. A suitable illuminated aperture would be imaged by the rotating scanner on the photograph to be transmitted. Straightforward optical layout and photomultiplier would take care of the light collection.

At the receiving point, the pictures can be re-recorded, using the Haller, Raymond & Brown type recording device which employs the Philips gas-discharge lamp as a modulated light source, or the combined optical scanner and modulator developed by the Baird Associates for Boston University. The electrical information recorded at the receiving point on unexposed film or paper can be developed rapidly with the Land process, thus reproducing the photograph at a distant point within less than half a minute after it is taken in the aircraft.

Here, again, an effort has been made to use existing techniques and equipment. As an alternative (or in addition) to the previous recording methods, the picture signals could be recorded on a magnetic tape using a system similar to that outlined in the previous section. With a tape speed of 100 inches per second, approximately 80 feet would be required for a 9x9 photograph.

#### D. TRANSMISSION OF RADAR-SCOPE PHOTOGRAPHS

The purpose of the system described in this section is to permit the viewing, at some distant point in the air or on the ground, of radar images as they appear in bombers, fighters, or reconnaissance aircraft. With line-of sight transmission or with airborne relays of orbiting aircraft, considerable distances can be spanned. (For example, two aircraft flying at 40,000 feet will have a line-of-sight for radio waves of approximately 500 miles.) If a coded transmission system were used, jamming by the enemy would be difficult.

The direct retransmission of radar video signals was first explored towards the end of World War II. The system discussed here utilizes a much narrower bandwidth and slower transmission time, which are made possible by an intermediate photographic process in the aircraft itself.

It is important that the bandwidth and the transmission time in a radar repeater system be kept to a minimum. By keeping the bandwidth low, the communication fre-

~~CONFIDENTIAL~~

~~SECRET~~

quencies chosen can be such that larger distances will be spanned and, at the same time, the power requirements at the transmitter (which would usually be airborne) could be moderate. The reasons for keeping the transmission time at a minimum are fairly obvious: radar information as seen in fast-flying aircraft should be conveyed to the distant point with as little delay as possible; furthermore, communication channels are apt to show least changes in their propagation characteristics over short periods of use.

As to equipment requirements, all phenomena, methods and components required to put such a system into operation are known; no fundamental development is required. A repeater scope in the aircraft is equipped with an aluminized sharp-focus tube using the new P-18 orange phosphor. A Land-type camera, using 35- or 70-mm film, is trained at this repeater scope. It is assumed that it would be sufficient to photograph every fourth or fifth radar scan - that is to say, approximately one picture would be produced every 10 seconds. The developed film, which can be a negative or positive, then automatically enters a special compact flying-spot scanner. This scanner operates at a vertical scanning speed of one-tenth of a cycle per second (the vertical scan lasts 10 seconds) and with a horizontal line frequency of 60 per second. Thus each frame of 10-second duration will contain 600 lines. The film frames emerging from the camera remain stationary in front of the flying-spot scanner for 10 seconds, after which the next frame is moved forward rapidly. The video bandwidth employed is 18 kc. The lowest frequency component will be that of the line-scanning frequency, namely, 60 cycles. Through the use of DC insertion at the beginning of each line, suitable synchronizing pulses will be generated and the composite signal will be transmitted over a modified communication transmitter, preferably FM-type. Applying the 18-kc modulation to AM-type transmitters, provided they are adapted for this wider bandwidth, would also be suitable.

The aircraft will have a permanent record of its radar mission in the form of the motion-picture frames and, at the same time, it will have transmitted the essential information to a distant point. At the receiving point, a more or less conventional wide-band AM or FM receiver, modified to handle the 18-kc modulation, can be employed. The synchronizing information is stripped from the composite video signal and employed to synchronize a flying-spot scanner, the intensity of which is modulated by the video signal. Motion-picture frames are exposed by this flying-spot recording system and developed in a standard continuous rapid-developing system or through the Land process.

The incoming signals can also be converted to reproduce the original radar-scope images at this receiving point for direct viewing. For this purpose, two loops of magnetic tape are used. Each loop is approximately 8 1/2 feet long and is threaded between a series of rollers in order to conserve space. An automatic switching system provides for the tape to run first at a speed of 10 inches per second for 10 seconds' duration. During this time period, the incoming radar picture signal is being recorded on the tape (and also as a permanent record on the film strip mentioned before). At the end of the 10-second recording period, the tape loop is automatically accelerated to run at a speed of 40 inches per second, and the resulting signal is fed to a scope using the long-persistent phosphor with rectilinear scanning which is synchronized from the signals off the tape. With the tape's reproduction speed of 40 inches per second, the vertical scanning on the scope would be once every 2 1/2 seconds, and the horizontal scanning

~~SECRET~~

~~CONFIDENTIAL~~

rate would be 240 lines per second. This scope image can be viewed for another 7 1/2 seconds, during which time the second loop of tape mentioned earlier is being used to record the incoming picture signal. At the termination of the 10-second period, the scope starts showing the next radar image from Loop # 2 which then is run at the higher speed, while Loop # 1 is switched to low speed to record the next radar image signal.

To summarize this process, the radar-image data transmitted from the distant aircraft can be utilized simultaneously in two ways at the receiving point: both a permanent film record and an intermediate tape record are made, the latter permitting direct scope observation.

As an alternative, the magnetic-tape intermediary viewing system can be dispensed with, and, if Land-type film were used in the recording camera, the developed film frames can be projected immediately on a screen.

#### E. BANDWIDTH AND CODING

The adaptations of television and facsimile systems outlined above were purposely designed around a narrow enough video bandwidth (250 kc and 18 kc) to facilitate long-distance transmission and to minimize multipath and jamming susceptibility.

Essentially, the problem becomes that of providing the necessary transmitting facilities in the aircraft, under severe limitations of space and power, to assure usable long-distance reception. Work has already been carried on in the direction of long-distance transmission of voice communication although, of course, the bandwidth requirements were much less than 250 kc. It is urged, therefore, that investigations to explore the long-range transmission possibilities with bandwidths up to 250 kc be initiated. Special consideration should be given to coded transmission, where the picture amplitude range is broken down into a number of discrete steps corresponding to combinations derived from a number of subcarriers. These need only to be turned on or off according to the proper code, rather than modulated in the conventional manner. For instance, if it were found that 8 discrete density steps would be sufficient to convey the necessary information of most aerial photographs, only three subcarriers would be required. This type of modulation can operate with very low signal-to-noise ratios. Moreover, multipath effects will be minimized, since one can employ amplitude clipping at the receiving point and select the strongest signal, rejecting the echoes which are usually of lower intensity. Because of the small signal-to-noise ratio requirements, such a type of transmission will also be less susceptible to jamming.

Since compact and light weight of equipment are essential, this type of transmission permits high transmitter efficiency, for linearity is of no consequence. The power is either fully on or off. The picture amplitude coding and decoding techniques are well known and, where a permanent record is desirable (such as at the receiving points), the coded method can be carried on to the magnetic tape, as outlined earlier.

#### F. OPERATIONAL ADVANTAGES

The use of photoelectric techniques as described in preceding sections offers varied advantages to reconnaissance operations. First and foremost is the over-all reduction in transmission time. Added to this is the insurance factor inherent in the recording of recon-

~~CONFIDENTIAL~~

~~SECRET~~

~~SECRET~~

~~CONFIDENTIAL~~

naissance information at a receiving station shortly after it is obtained by the aircraft. Other obvious advantages are inherent in the immediate availability of reconnaissance information at theater headquarters and bomber wings, enabling continuing evaluation of targets to be made.

We recommend that proven photoelectric techniques and equipment be applied to the problems of transmission of reconnaissance information between aircraft and ground and between the reconnaissance vehicle and another aircraft. At the same time, we urge the exploration of long-distance transmission with bandwidths up to 250 kc.

~~CONFIDENTIAL~~

~~SECRET~~



~~SECRET~~

~~CONFIDENTIAL~~

CHAPTER 9

RADAR

A. INTRODUCTION

Looking at the way in which radar is used today in the Air Force, we are impressed by two things: first, the reliance on radar as a substitute for visual observation is greater than ever; second, the inherent capability of the basic radar equipment is not growing, but is actually shrinking. Few will quarrel with the first observation. High-altitude operations under existing weather conditions and high speed at low altitudes have nearly put the human eye out of the bombing business; and cloud cover over the target areas will render both camera and eye useless much of the time in reconnaissance operations.

The deterioration of the basic radar capability has not been so conspicuous because it has been offset by the strenuous effort in SAC to improve the whole operation of radar bombing by rigorous training and more elaborate auxiliary devices. Radar is actually used more effectively today than it has ever been before, and nothing we say is meant to disparage this real achievement. But we must not let it obscure the downward trend in the information-gathering ability of the instrument itself. Resolution and range are still the essential measures of a radar set as a sensing device. The present standard equipment, APS-23, has an angular resolution only about twice as good as that of the radar used by the Eighth Air Force in 1943, and less than half as good as that of the now-abandoned APQ-7. We learn that designers of future aircraft look forward to further reduction in antenna size and radar resolution. The present plans for the MX 1626 call for a 45-inch radar aperture - compared to 60 inches in the APS-23. It is as though, in aerial photography, one were obliged to use cameras of shorter and shorter focal length, with no compensating increase in film resolution. This compromise, we are told, has been forced by the exigencies of modern aircraft design - in other words, the problem of designing a high-performance radar into a high-performance aircraft has not been solved.

Acceptance of this situation seems to have been made easier by two notions that appear to underlie much that we have heard: (1) "No more big advances are possible in the microwave elements of the radar system: what radar is, apart from the means of presentation, is defined more or less finally by the APS-23 components. (2) "Radar - again defined by APS-23 - gives us a lot of information that we don't recognize and use: if this latent information could only be extracted, we wouldn't need a narrower beam to distinguish what we want to see."

These notions, if they should really exist, would strike us as expressions of an attitude of despair. We believe that both are fundamentally incorrect. We believe that higher resolution is both attainable and necessary. A considerable part of this chapter will be devoted to that subject.

Airborne radar, whether for bombing or for aerial reconnaissance, is now seriously handicapped by poor angular resolution. Much of this is due to the forced reduction of antenna size in modern aircraft.

~~CONFIDENTIAL~~

~~SECRET~~

~~CONFIDENTIAL~~

~~SECRET~~

Radar reconnaissance and radar bombing have been so closely linked that it is hard to separate them in any general discussion. There is a tendency to think of radar reconnaissance solely as the operation of gathering prestrike radar-scope photos for the purpose of enabling the radar bombardier to correctly identify his aiming point. This conception of radar reconnaissance leads naturally to the notion that the reconnaissance radar had best resemble the bombing radar as closely as possible. Once this doctrine is established, the ability of the reconnaissance radar to collect other important intelligence is pretty well restricted, and the circle is complete. Whether radar can perform other important reconnaissance functions is a question we need to discuss; to approach it as an open question we must lift it out of the narrower context of the bombsight problem.

Even while radar antennas in bombers are being squeezed down in size, there is a growing recognition of the desirability, perhaps the necessity, of using fighter-type aircraft for many reconnaissance operations. One could scarcely take seriously the notion of carrying a high-resolution radar in a modern fighter so long as the radar set was conceived along conventional lines. The situation reminds one of an ever-tightening knot.

One of the most encouraging - indeed, exciting, things we have learned from our study is that there is an escape from this seemingly hopeless situation. The way has been opened by two essentially very simple ideas that have found embodiment in the experimental APQ-38 radar. One idea is that of using the aircraft's motion to scan the ground, thus generating continuously a strip map. The other idea is that of using a fixed array running longitudinally along the aircraft to form the transverse radar beam that is capable of attaining much higher resolution without penalizing the performance of the aircraft; it is a system that is actually simpler, in some important respects, than a conventional radar. This impresses us as the most important advance in pictorial radar since the war. We have explored some of its possibilities and propose, among other things, the development of a simple high-resolution radar for nose installation in a fighter-type reconnaissance aircraft such as the RF-84F or RF-101. It appears feasible to achieve angular resolution of 0.4' or better at little cost in aircraft weight or performance.

It is too early to say how the introduction of the side-looking technique will change the radar bombsight problem. Certainly side-looking radar is very poorly adapted to the present bombing procedure, and naturally so, for present bombing procedures have evolved from the exclusive use of forward-scanning radar. We see no reason why effective bombing techniques based on side-looking radar cannot be devised. In fact, this approach offers certain advantages, especially in connection with the use of terminal missiles. We are informed that the British are developing a method of this sort.

Even if bombing continues to be done by forward-scanning radar, prestrike radar reconnaissance can usefully be carried out by the side-looking strip-recording method. This is a rather unorthodox idea, in view of the present emphasis on exact duplication in the prestrike reconnaissance run of the eventual radar situation during the bombing run. This emphasis we believe to be somewhat misplaced for reasons that will be discussed in detail in connection with the problem of radar prediction. The most essential and reliable radar facts about the target can be obtained with any radar of sufficiently high resolution, properly used. In

~~CONFIDENTIAL~~

~~SECRET~~

~~SECRET~~

~~CONFIDENTIAL~~

particular, a reconnaissance aircraft equipped with side-looking radar can fly a course at right angles to the eventual axis of attack and thus see the target from approximately the same aspect from which it will be seen in the attack.

We believe, too, that a substantial improvement in resolution in the prestrike pictures, even if not accompanied by a corresponding increase in the resolution of the bomb-sight radar, would benefit the whole operation by making the identification and location of targets and aiming points more certain and accurate.

The most hopeful development in reconnaissance radar is the fixed side-looking array combined with strip mapping. It makes high-resolution radar feasible for even fighter-type reconnaissance aircraft.

Looking a little further ahead, one naturally asks whether high-resolution radar will be able to substitute for photography in the collection of target intelligence. If the question is very narrowly interpreted, the answer is probably no. We doubt that it will be possible to reduce the smallest resolved patch on the ground much below 50 feet in size, at ranges as great as 10 or 15 miles. There will always be a wealth of detail that photography, under good conditions, can record and radar cannot. Granting this, however, there is reason to believe that if we can reduce the width of the radar beam to one or two-tenths of a degree - which seems within reach of the side-looking method - the radar map will contain a significant fraction of the useful intelligence for which we now have to rely on photography. At the very least, the radar will distinguish sharply between natural features and man-made installations; it should disclose roads, railroad right-of-ways, airstrips, isolated factories. How much more it may see we can't know until it is tried.

All these considerations point in the direction of shorter wavelengths, as well as larger antenna apertures. One must therefore consider very carefully the inherent disadvantages of the shorter wavelengths, with respect to propagation through the atmosphere. These factors are treated in some detail in Section E of this Chapter. We reach the conclusion that shorter wavelengths are, on the whole, to be strongly recommended, and that, in particular, the  $K_u$  band, around 1.8 cm, ought now to be established as the basic airborne-radar wavelength.

The vulnerability of radar to jamming calls for some consideration in connection with any radar development; this question is treated in Section G. We do not believe that jamming will be a serious threat if the development of airborne radar proceeds in the directions recommended in this Report.

#### B. THE NATURE OF RADAR INFORMATION

Pictorial radar has been in use in the Air Force for nearly 10 years. Its main features are not much more mysterious than those of the internal combustion engine. Since most of the readers of this Chapter have been closely concerned with radar, a review of the elements of radar is hardly called for. But certain facts are worth reiterating, and there is one point - a subtle but essential point - that seems to have been rather widely misunderstood. We begin by recalling some familiar facts.

~~CONFIDENTIAL~~

~~SECRET~~

~~CONFIDENTIAL~~

~~SECRET~~

Radar is a substitute for optical vision, but it is not like optical vision. In fact, it is different in so many ways that we tend to forget some of these ways, and are tempted to make assumptions that would be valid in the optical case but are incorrect or irrelevant in the case of microwave radar. There is the very obvious difference in the primary method of locating objects - by distance and angle in radar, by two angles in vision or photography. The angular discrimination in radar, as we now know it, is much coarser than we are accustomed to in optical perception. Radar lacks the dimensions of color, but so does ordinary photography. A more important restriction in radar is that the source of illumination is necessarily at the observer. An object is perceived only by the radiation it scatters directly back toward the source. There is some resemblance here to the situation in flash photography.

Radio waves, including microwaves, are reflected more strongly by most substances than are light waves. Metals, whether painted or not, are practically perfect reflectors; a dry insulator, at the other extreme, may reflect at normal incidence as little as 10 per cent of the energy that falls on it. But this is a range of only ten to one in intensity, at most, and it is not really very significant, for reasons we shall discuss shortly. For microwaves, most man-made surfaces are "shiny" in the sense that they contain areas both large compared to a wavelength and smooth on the scale of a wavelength. Except for some difference in average intensity, a building made of steel, an exact replica of the same building in wood, and a replica in solid glass, would give pretty much the same radar return. As a very crude optical analogy to the radar situation: imagine almost every surface in a city - every wall, roof, and chimney - to be chromium-plated, but with a few buildings coated with polished glass. Imagine a night flash photograph of the city taken from a considerable distance when the city is "blacked out." Then imagine trying to discover in the photograph which buildings were chromium-plated and which were coated with polished glass. The surface-material contrast available to radar is even less than this.

We come now to perhaps the most essential and least-understood difference between radar and vision (or photography). This has to do with the nature of the radar echo from a complex target. The signal entering the radar receiver at a particular instant is the sum of individual wavelets reflected from different points within a certain patch of terrain. The dimensions of this patch are determined by the angular width of the radar beam, by the range, and by the pulse duration. At 15 miles from an APS-23, for example, the patch is about 2000 feet by 200 feet in size. Usually such a patch will contain not one reflecting element but several, whose individual reflections can be thought of as combining at the receiver to give a single result, just one signal of a certain intensity. It is clear that this one echo cannot give detailed information about the individual scatterers, and that, of course, is why the 2000 x 200-foot pulse packet sets the limit to radar resolution in this case. What is not so obvious is this: the sum of the individual wavelets that make up the echo is subject to large and essentially random fluctuations when the geometry of the system changes only slightly. If the identical collection of scatterers is viewed from a slightly different angle, for example, the total echo may easily be twice as intense as before, or half as intense. The chance that it will be three times as large is by no means negligible. The variation is due to the interference among the wavelets that make up the total instantaneous echo. It is for all practical purposes wholly random -

~~CONFIDENTIAL~~

~~SECRET~~

that is, unpredictable from one sample to the next.

It is a mistake to assume that, when the pulse packet contains many reflecting points, the statistical fluctuations will be relatively minor. One of us once fell into this error, and we sympathize with anyone else who does so. But the sad fact is that the probability of a given percentage fluctuation in the total echo is the same, however large the number of scatterers contributing. Neither is the rapidity of fluctuation dependent directly on the number of scatterers. These facts and the reasons behind them are well established.\*

The practical consequence of all this is the "scintillation" of radar echoes, which, in one way or another, plagues every user of radar. There is no very close parallel in vision or photography; the processes are fundamentally different.

We have labored this point because it is absolutely basic to an understanding of the capabilities and limitations of radar. What does it mean? For one thing, it means that the intensity of a single radar echo, no matter how complex the target from which it comes, contains only a very limited amount of information. The intensity of the echo has only a rough statistical significance. That is why, if we look at one echo, the difference in reflecting power between various substances is not significant as a distinguishing characteristic; it is masked by the random factor arising from the interference. For the same reason, we cannot hope to predict the strength of the echo, from any complex target, except in order of magnitude. We can, in principle, make a more accurate prediction about an average echo intensity from a given "patch," and rather elaborate theoretical analyses of this sort have been carried out.\*\* But this is largely beside the point, for radar, as now used, does not perform such an average, but presents to the radar observer as a rule only one random sample of an elementary patch, not the average of many independent samples. This is because the fluctuations do not occur rapidly enough under the usual conditions of speed, altitude, range, and wavelength, to provide many independent samples within the effective "memory" period of the radar display.

There are certain ways in which we might hope to get a representative average, and thus to increase the significance and the predictability of the echo. The double-frequency radar is a step in this direction, but a very feeble step and a very costly one; it only doubles the number of samples averaged. There are other possible approaches to the same problem that seem to us more effective. At best, these schemes can only moderately increase the basic information content of the radar picture by softening some of the unpredictable fluctuations, so that more-predictable target characteristics can emerge.

There is another important cause of echo variation in the "flat plate" and "corner reflector" effect which causes a flat surface normal to the line of sight, or two surfaces meeting at right angle to the line of sight, or an "inside" corner in almost any orientation to return an exceptionally strong signal. This effect is most conspicuous, of course, in built-up areas. The "cardinal point" effect which shows up in the radar returns from rectangularly laid-out cities is only a special case. The return from any cluster of buildings is, to a considerable degree, influenced by these special mirror properties, the accurate prediction of

\*See, for example, Radiation Laboratory Series, McGraw-Hill (New York, 1951), Vol. 13, Chap. 6.

\*\*For example, Theory of Radar Intelligence, Aircraft Radiation Lab., WADC, Map Display Unit, Technical Proceedings, DU21.

~~CONFIDENTIAL~~ ~~SECRET~~

which would require very accurate knowledge of the relative positions of the various surfaces.

Much of the detail that appears on any single radar-scope picture depends on these essentially unpredictable factors. Such detail is to that extent meaningless. It is like the shape of a cumulus cloud, which is also rich in meaningless detail. It is the failure to recognize this, perhaps, that accounts for the prevalent notion that the radar picture is full of latent information that we are somehow failing to exploit. Anyone who clings to this notion should examine carefully and objectively the results of the study by Engineering Research Associates\* of the degree of correlation of radar-signal intensity with target characteristics.

Possibly we do not get the very maximum amount of information out of a radar picture by merely looking at it carefully, but the additional amount to be gained by elaborate analysis is slight. There isn't much information in a photograph that doesn't meet the eye, and there isn't much on a radar picture either. If a photograph of unknown terrain has been taken with the camera out of focus, one cannot restore to the picture the information that has been lost. One can dub color into the picture, create a pseudo-stereoscopic effect, cross-correlate this with that, but you can't increase the amount of information in the picture.

We believe the emphasis on presentation as the key to radar interpretation is very much misplaced. It is time to stop spending money on schemes to extract from the radar picture information that isn't there in the first place, and to face the cold fact that what is needed to improve airborne radar is better resolution.

Because of the fundamental limits set by the nature of radar information, no great improvement is to be expected from elaborate presentation schemes.

#### C. RADAR PREDICTION AND RADAR INTERPRETATION

Lack of radar photographs of strategic targets has created the immediate and serious problem of radar prediction. One must somehow decide, using maps and vertical photographs, what the radar echoes from a city or other target complex will look like. Then by some means - the supersonic trainer, for example - one has to present this hypothetical scope picture to the radar bombardier in a realistic form. This last step is radar simulation, and it should be carefully distinguished from the first step, which is radar prediction. Prediction is the crucial step: if the prediction is wrong, the simulation will only embellish and reinforce the error. The predicted scope picture must be accurate enough to enable the bombardier to match it properly to the actual radar picture, which he sees for the first time on his bombing run, and so to identify his assigned aiming point among the constellation of echoes.

We are impressed by the progress that has been made, by hard work and practice, in the prediction problem. At the same time, we are disturbed by certain things. We feel that too much confidence is placed in prediction methods as such. We believe that there are fundamental limits to the reliability of any radar prediction - limits that have not been clearly recognized. We do not say that the present prediction scheme gives bad results, but rather that no prediction scheme is feasible that would justify the confidence - or hope -

\*(Contract AF33(038)-14317)

~~CONFIDENTIAL~~

~~SECRET~~

~~SECRET~~

~~CONFIDENTIAL~~

that radar prediction appears to inspire.

In the document Radar Target Prediction Procedures,\* the statement is made (page 5) that radar prediction is now "90 per cent accurate." Turning to the one comparison of a predicted with an actual scope picture that illustrates that report, we find in the middle of the actual radar configuration of Birmingham, Alabama, a great blob that is missing entirely from the predicted pattern and that markedly alters the radar face of Birmingham, as seen at that particular moment. One must not forget that the addition or subtraction of a few strong echoes can change the appearance of a cluster of returns in a way that will defeat recognition.

The fickleness of the radar map is due to the fluctuations mentioned in the last section and to the extremely sensitive dependence of the radar echo upon the geometrical details of the target. To make a really reliable prediction, it would be necessary to go over a city with a micrometer, determining the position of all details to the nearest eighth of an inch, to survey in the position of the aircraft, and to feed this mass of data into a large computing machine. Since we can't do this, we must recognize that any practical prediction scheme will be liable to substantial errors. It will predict some strong echoes where none are seen, and vice-versa.

Some of the statistical fluctuations can be reduced by averaging, and in that way a more stable and predictable pattern may be achieved. Present radar indicators do this more or less inadvertently, as a result of inadequate focus in the cathode-ray beam. Several otherwise resolvable patches are smeared together (in range) on the tube face. Whether the gain in "stability" is worth the cost in resolution is very doubtful.\*\* Some further considerations of the echo fluctuation and means for increasing the recognizability of targets are contained in Appendix E. Despite any such palliative measures, the inherently unpredictable elements of the radar problem remain, and with the present equipment they represent a basic limitation on what can be achieved in the way of prediction.

In this situation, simple empirical prediction procedures are the best. The procedures that have been worked out are, in the last analysis, empirical in nature, and our only criticism of them is that they are, if anything, too complicated. The standard method is so elaborate, with many different factors and long tables of numbers, that it looks more scientific than it is - and this alone tends to engender false confidence. The trouble with an empirical formula containing many variables is this: It is practically impossible to perform, even under laboratory conditions, enough different experiments to verify all the factors separately. Unless the variables in the formula can be tested independently, there is no assurance that the formula will not fail unexpectedly in a new situation.

To take one example, the prediction doctrine outlined in Radar Target Prediction Procedures\*\*\* arbitrarily assigns relative factors of 8 and 1, respectively, to steel and wood construction. It is certainly reasonable to expect some difference in signal strength

\*Directorate of Intelligence, DCS/O, December 1950

\*\*If one is obliged to smear out the spots, it is probably better to narrow the video band accordingly, in order to effect the averaging in a linear filter rather than on the phosphor.

\*\*\*Ibid.

~~CONFIDENTIAL~~

~~SECRET~~

~~SECRET~~

~~CONFIDENTIAL~~

on the basis of material alone. Whether it should be as great as this appears doubtful to us,\* but the question is wholly academic, for the only practical test possible is a comparison of two areas, one containing steel buildings and one containing wood buildings which necessarily differ in other respects as well. In other words, the geometrical factors and the material factors are not separable by direct radar test; any theoretical separation of them should be treated with extreme suspicion.

To illustrate the point in another way, suppose we wanted to allow for the effect of glass surfaces, such as large window areas, on the radar echo of a group of buildings. Now a sheet of glass 5/32-inch thick very strongly reflects 3.2-cm waves incident on it perpendicularly. Owing to the reinforcement of the reflections from the front and back surfaces, the reflection coefficient is higher than that of a solid brick wall. A sheet twice as thick will reflect nothing at normal incidence, but will reflect strongly at some other angles. It is obvious that the effect of glass windows on the radar return cannot be expressed by any simple formula, even if we had complete information on the thickness of all windows in our strategic targets. Any formula that pretends to allow, by some factor, for the presence of glass is absolutely specious. It would be even more erroneous to treat glass areas as though they did not reflect at all. The only sound procedure is to treat them exactly the same as any other surfaces.

The point here is that improvement in radar prediction will not come through the introduction of more factors into the formulas. The formulas already contain more factors than can be experimentally validated.

The prediction problem will not be solved by the ultrasonic-tank technique, either. The ultrasonic tank is strictly a simulator only, not a predictor. It is quite impossible to duplicate the target in such a way as to create an accurate scaled-down replica of the whole physical situation which will automatically produce a correct radar prediction.\*\* We seriously question the wisdom of further investment in refinement of the supersonic trainer. It would be justified only if the "realism" of the simulation is inadequate for training purposes. The accuracy of the simulation depends on the radar prediction, and to that problem the ultrasonic technique has nothing to contribute.

What is really now needed is more extensive testing of the predictions, under realistic conditions, against all sorts of target complexes. Some of this has been done, we know, but not nearly enough to establish reliable confidence limits. A cold-blooded, skeptical analysis to the operation might well reveal ways in which the prediction method could be simplified without loss of reliability. But quite apart from that, it is essential to know how much reliance can be placed on radar prediction, and hence, conversely, how much prestrike radar reconnaissance is absolutely necessary. Specific suggestions related to prediction and evaluation of prediction methods are made in Appendix G.

\*At Rapid City AFB, only one hangar is metal-encased. All the other structures are of wood, yet all returns are of about equal intensity; at least it is not possible to distinguish the steel structure.

\*\*A very cogent discussion of the inherent limitations of the supersonic method has been given by D. E. Farmer in a report entitled Technical Considerations in Radar Simulation by Ultrasonics. Radar Target Section, Directorate of Intelligence, USAF, March 1951.

~~CONFIDENTIAL~~

~~SECRET~~



Turning now to actual radar reconnaissance, we meet the problem of radar prediction in reverse. We have the scope photos, and the question is: Where is the target and what shall be used for an aiming point? This is a problem in radar interpretation. It is not always an easy problem, and, as has been emphasized elsewhere in the Report (App. G), mis-interpretation at this stage makes an irreversible contribution to the CEP. Again the fundamental difficulty arises from the essentially unpredictable elements of the radar view. Indeed, unpredictable and uninterpretable are here nearly synonymous. The only way to improve the situation very much is to improve the resolution of the picture. Even a modest gain in resolution may make recognition and identification much more positive. If the radar map of a city is a collection of amorphous blotches, gross errors in the identification of a blotch are possible. As soon as a few streets, roads or railroads can be recognized, the correlation with a map or photograph is established beyond any doubt.

In much the same way, improved resolution in the radar bombsight will simplify the problem of radar prediction. We refrained from injecting this into our earlier discussion of radar prediction, which was directed toward problems as defined by existing equipment. Anything that makes the radar view of the city look more like the plan of the city will make proper recognition more certain. The real trouble with radar prediction and radar bombing as presently done is the wretchedly crude picture that one gets at 15 or 20 miles from the target city, and the confusing "break-up" which gets worse as distance to the aiming point decreases.

There are fundamental limits to the reliability of any radar prediction. Therefore, efforts to improve prediction should concentrate on the simplest procedures now in use and the validation of these by more extensive operational trials. Work on more elaborate methods is not promising.

#### D. RADAR RESOLUTION

Resolution is the key to radar reconnaissance. This conclusion seems to us inescapable. Let us recall how matters stand now, and then look at what might be achieved within the fundamental limitations set by nature, putting aside, for the present, the artificial limitations created by particular vehicles and by the conventional conception of airborne radar.

The dimensions of the smallest resolvable patch on the ground, in ordinary pulse radar, are set by the pulse duration  $\tau$ , and the angular beamwidth  $\theta$ . It is true that further deterioration of resolution may occur in the radar presentation if the spot on the cathode ray tube is too large, but this is another problem, discussed separately in Appendix F. At the present time, the pulse duration is not a limiting factor, compared to beamwidth. In the APS-23 radar, the shortest pulse available has a duration  $\tau = 0.4$  microsecond, corresponding to a range interval of 200 feet. There is no technical problem in generating and handling pulses as short as 0.1 microsecond, if that were desirable. Actually, extremely short pulses may have some utility in dealing with complex targets, if the accompanying sacrifice of average power can be tolerated or avoided by a special trick (see Appendix E).

~~CONFIDENTIAL~~

~~SECRET~~

But this does not bear directly on the pictorial resolving power, which at present is most seriously limited by the beamwidth  $\theta$ .

The beamwidth in APS-23 (1.4°) results in a minimum resolvable patch width of about 1/40 of the range, that is, about 1500 feet at 10 nautical miles, 3000 feet at 20 miles, etc. (This is roughly 100 times coarser than the resolving power of the eye!) The narrowest radar beam used operationally in aircraft is that of the APQ-7 radar, whose beamwidth is 0.4 to 0.5°. Both these radars, of course, employ a wavelength of 3.2 cm. The recently tried APS-48 which uses a wavelength of 1.8 cm ( $K_u$  band) if equipped with a 60-inch-wide antenna similar to that of the APS-23, would have a beamwidth of about 0.8°.

So far as we know, the narrowest microwave beam that has been carefully investigated was the 0.1° beam used in the transmission experiments of Crawford.\* This beam was achieved with an antenna of 20-foot aperture, operating on a wavelength of 1.25 cm. Crawford's experiments indicated that propagation effects did not seriously affect the resolution even under much worse conditions than would be encountered high in the air. We can safely regard the air as a homogeneous medium for beams as narrow as this - and probably a good deal narrower. (The Mt. Palomar telescope manages to work with an "antenna" about as large as this and a beam 20,000 times narrower!)

The real obstacle to higher resolution, as everybody knows, is the size of the antenna required. The elementary relation between antenna width  $d$ , beamwidth  $\theta$  and wavelength  $\lambda$  is approximately

$$\theta \text{ (degrees)} = 60\lambda/d$$

To make a 0.1° beam at X-band (3.2 cm) requires, according to this formula, an aperture about 60 feet long; at  $K_u$  band (0.85 cm) on the other hand, the aperture required is only 16 feet.

Is there any way to beat the rule expressed by this formula? Since World War II, at least two notions have attracted some attention. A brief flurry of interest was aroused some years ago by the so-called "super gain" antenna, a theoretically correct scheme for achieving a beam narrower than the above formula would allow with an antenna of given physical size. It was soon recognized that the scheme, from a practical standpoint, is utterly useless for achieving a very narrow beam, and the idea has been decently interred in the literature.\*\*

A quite different approach is represented by the scheme imperfectly described by the term "monopulse." Two versions of this have been developed, by General Electric and Maxson, respectively, under Air Force contracts. Roughly speaking, both attempt to "undo" the smearing caused by finite beamwidth by operating on the signal after it has been received. There is no doubt whatever that by such methods isolated point targets can be located with an error much smaller than a beamwidth. We are far from convinced that, in pictorial radar applied to complex targets, such schemes will indeed be equivalent to a narrower beam. There is no need to argue the point, for both methods are reported to be nearly ready for full trial. For completeness, we should mention a proposal, due to L. W. Alvarez, for overcoming the

\*A. B. Crawford and W. M. Sharpless, Further Observations of the Angle of Arrival of Microwaves, Proc. I.R. E. 34, 845(1946).

\*\*L. J. Chu, Physical Limitations of Omnidirectional Antennas, J. A. P. 19, 1163(1948).

~~CONFIDENTIAL~~

~~SECRET~~

~~SECRET~~

~~CONFIDENTIAL~~

beamwidth-antenna size relation by the use of frequency multiplication. This is especially pertinent to certain low-frequency problems; it does not appear to have any usefulness at the microwave limit of the spectrum. Another proposal, advanced by C. W. Sherwin, is discussed in greater detail in Section J of this Chapter.

It is our firm belief that the best and simplest way to improve radar resolution is to use a wider antenna and a shorter wavelength. The mere change to 1.8-cm wavelength, as the comparative tests of APS-23 and APS-48 have already shown, brings a significant increase in meaningful target information. Surely it is not being very bold to imagine an antenna aperture no bigger than that of the APQ-7 - 15 feet long by 5 inches high - on a plane as large as a B-36. Operating such an antenna at 1.8 cm, we would obtain angular resolution of about  $0.25^\circ$ . This would be an improvement by more than five times over the APS-23; it would radically simplify the problems of radar prediction and of aiming-point recognition.

These seem like timid steps indeed when we consider the progress that has been made in aircraft performance. At the very minimum, one should expect an increase in bomber speed by a factor of two to be accompanied by a reduction of the radar beamwidth by a factor of two because of the consequent increase in the distance between target and release point. Even this minimum requirement has not been met. The radar bombardier in a B-24 had a better view of his target than has the USAF bombardier of 1952.

Let us consider briefly what the ultimate limit of radar resolution may be. As explained in the next section, atmospheric attenuation will probably limit us to the use of wavelengths of 0.8 cm or longer where ranges of the order of 15 or 20 miles are required under average conditions. Now if we do not limit the antenna aperture  $d$ , there is nevertheless a limit on the resolving power for a given maximum range  $R$ . This comes about because, unless the antenna is focused on some nearer point, the antenna beam goes out as a parallel ribbon from the antenna, for a distance of the order of  $d^2/\lambda$ . The result is that, out to some range  $R \approx d^2/\lambda$ , the width of the resolved patch is constant and is simply  $d$ . For  $R = 15$  miles and  $\lambda = 0.85$  cm, this rough relation gives  $d \approx 50$  feet. In other words, once the  $K_a$  wavelength is chosen, 50 feet is about the maximum resolution obtainable over a 15-mile range, and 50 feet is also the maximum antenna length of interest.

For shorter ranges and higher resolution, we ought to look forward to the eventual use of a wavelength in the neighborhood of 0.35 cm. Although the range will be severely limited in comparison with conventional long-wave radar ranges, millimeter waves are still vastly superior to light and infrared for penetrating clouds (see Tables 9-3, 9-4, 9-5 in Section E). For example, low-level reconnaissance cover of a strip 10 miles wide (5-mile range) should be possible under all conditions except moderate to heavy rain. If we choose  $\lambda = 0.35$  cm and  $R = 5$  miles, we find  $d \approx 20$  feet - that is, a 20-foot antenna would project a 20-foot-wide ribbon beam out to 5 miles. With an appropriately short pulse, which presents no serious problem, this would enable a 10-mile-wide map to be recorded in 20-foot by 20-foot elements. A 10-mile square would contain as much detail as a 70-mm film resolving 20 lines per millimeter. On the basis of what we know today, this is about as far as radar resolution can go. It is by no means a fanciful goal; there is no apparent obstacle except the hard work needed to develop suitable 0.35-cm components.

~~CONFIDENTIAL~~

~~SECRET~~

Resolution is the key to radar reconnaissance. The best and simplest way to improve radar resolution is use of a wider antenna and a shorter wavelength. Some improvement in present radar equipment can be achieved by the use of cathode-ray tubes with sharper focus.

#### E. RADAR WAVELENGTHS

In the spectrum below the 3-cm wavelength, there are three bands that look promising - in different ways - for airborne radar. The  $K_u$  band (around 1.8 cm) includes the shortest wavelengths substantially unaffected by the water-vapor absorption line centered around 1.3 cm. The  $K_a$  band (around 0.85 cm) is the most favorable location between the regions of water-vapor absorption and the oxygen absorption line at 0.6 cm. Below the oxygen line, there is another absorption minimum, in the neighborhood of 0.35 cm, which is probably the last useful "window" in the microwave spectrum.

We now have accurate and reliable laboratory measurements of the oxygen and water vapor absorption lines. For any specified meteorological conditions, the absorption in the  $K_u$  and  $K_a$  bands can be calculated more accurately than it could be measured by radar methods. More work is needed in the 0.35-cm region, but even there the present estimates are not likely to be very far wrong. The main difficulty in assessing the effect of atmospheric attenuation on radar performance arises from incomplete knowledge of the meteorological factors.

The effect of clouds and rain in attenuating radar signals can likewise be predicted fairly reliably if the liquid water content and drop size are known.\* The work of Ryde, and others since, has established a satisfactory empirical correlation between attenuation and precipitation rate for various wavelengths. In the case of ordinary cloud cover or fog, only the water content is significant.

We have tried to assemble the best available information on these effects and to present it in such a way as to bring out the practical consequences of the attenuation. For this purpose, we have chosen three representative surface conditions of temperature and humidity. These are called conditions A, B, and C, and are specified in Table 9 - 1. Some knowledge of the variation of water vapor concentration with height is required; our assumption, which is based on rather limited data, is that the total water vapor content in a vertical column is equivalent to that in a 7000-foot horizontal column at the ground. As a very rough indication of the prevalence of conditions better or worse than one of these arbitrary "standards," we show in Table 9 - 2 figures based on monthly averages recorded in the N. I. S. meteorological tables\*\* for the four cities of Eastern Europe.

Fog (or cloud) and rain are treated separately, in Tables 9 - 4 and 9 - 5, that is, conditions A, B, and C and Table 9 - 3 in which they are used, pertain only to the gaseous absorption. The attenuation due to various causes is simply additive.

\*For example, see Radiation Laboratory Series, Vol. 13, op.cit., Chap. 3.

\*\*National Intelligence Survey, AF-202118, NIS 26-IV, Section 23.

~~SECRET~~

~~CONFIDENTIAL~~

TABLE 9-1: REPRESENTATIVE WEATHER CONDITIONS  
(A is more favorable than B; B is more favorable than C)

Condition	Ground Temperature °F	Relative Humidity (per cent)
A	32	85
B	50	80
C	68	75

TABLE 9-2: MONTHLY AVERAGE GROUND CONDITIONS\*  
(Number of Months per Year at Various Localities)

Condition	Archangel	Moscow	Warsaw	Kharkov
A (or better)	6	5	3	4
B (or better)	9	7	6	7
C (or better)	12	12	12	11

\* Equal to or more favorable than one of the selected standard conditions.

TABLE 9-3: EFFECT OF ATMOSPHERIC ABSORPTION ON RADAR RANGE\*  
(Rain and Overcast Excluded)

Ground Conditions	λ			
	λ = 3.2	λ = 1.8	λ = 0.8	λ = 0.35 cm
Radar at ground level or only a few thousand feet above	A 330 B 280 C 215	160 100 60	50 35 23	12 9 6
Radar at 30,000 feet	A >500 E >500 C >500	450 320 200	125 100 75	45 36 25

\* Table gives range to target, in nautical miles, for 10 db attenuation on round trip path.

TABLE 9-4: ATTENUATION BY CLOUDS AND FOG\*

Characteristics of Cloud	λ = 3.2	λ = 1.8	λ = 0.8	λ = 0.35
0.03 gm liquid water per m <sup>3</sup> optical visibility 2000 ft	> 500	> 500	150	30
0.3 gm liquid water per m <sup>3</sup> optical visibility 400 ft	200	75	15	3
2.3 gm liquid water per m <sup>3</sup> optical visibility 100 ft	30	10	2	0.4

\* Table gives thickness, in nautical miles, of fog or cloud, measured along radar line of sight, for which 10 db of attenuation is added to round trip path.

TABLE 9-5: ATTENUATION BY RAIN\*

Characteristics of Rain	λ = 3.2	λ = 1.8	λ = 0.8	λ = 0.35
light - 1 mm/hr	300	75	12	3
moderate - 4 mm/hr	60	13	3	1
heavy - 16 mm/hr	10	3	0.7	0.4

\* Table gives thickness, in nautical miles, of rain, measures along line of sight for which 10 db attenuation is added to round trip path. (Note: Effects of wet radome and rain clutter are often worse than those of attenuation!)

~~CONFIDENTIAL~~

~~SECRET~~

~~CONFIDENTIAL~~

~~SECRET~~

We adopt, as a measure of the seriousness of the attenuation effects, the radar range for which 10 db of attenuation is accumulated in the round trip path. This range, in nautical miles, is entered for each assumed condition in Tables 9-3, 9-4 and 9-5. The figures for altitude 30,000 feet refer to the slant range from a radar set at that altitude looking at the ground. The 10-db figure is, of course, arbitrary, but it represents perhaps as well as any one figure can the dividing line between a loss that is serious and a loss that is not.

The use of the tables is best explained by an example. Suppose we have a  $K_a$ -band radar at 30,000 feet, the ground conditions being nearest to Condition B. In the absence of rain and cloud, a ground target at 100 miles slant range (entry in Table 9-3) will be subject to 10 db attenuation, 5 db out and 5 db back. Targets at twice this slant range will return echoes 20 db weaker than in the absence of an atmosphere, and so on. Now suppose that somewhere below 30,000 feet we have a cloud layer one mile in vertical thickness, with conditions in the cloud corresponding to 0.3 grams of liquid water per cubic meter, which is roughly correlated with a local visibility of 400 feet. The corresponding entry in Table 9-4, 15 miles, means that the radar has to look through 15 miles of cloud to suffer 10 db attenuation, round trip, from that cause alone. A ground target at slant range  $R$  is separated from the radar by a slant thickness of cloud amounting to

$$R \left( \frac{\text{vertical thickness of cloud}}{\text{vertical height of aircraft}} \right)$$

or  $R/5$  miles in this case. Hence the cloud will contribute 10 db attenuation when the slant range is 75 miles. We can combine this result with the effect of the gaseous attenuation, by a little arithmetic, and thus find that a total attenuation of 10 db, from cloud cover and atmosphere, occurs for a slant range of 42 miles.

The figures in the tables speak for themselves, but we wish to call attention especially to the importance of taking into account the relative frequency of various weather conditions over the target areas. We suggest that it is not wise to require that all radars give maximum range 95 per cent of the time, if we thereby exclude the possibility of getting much better information by means of a radar that will work at its best only 75 per cent of the time. After all, visual photography over the U. S. S. R. is not expected to be feasible at all 90 per cent of the time, due to prevalence of cloud cover. We suggest also that a radar should be judged by what it will do over the Soviet Union, not what it will do over Florida. Let us not handicap radar reconnaissance over northern Europe and Asia by the equivalent of a "tropicalization" requirement.

It is our conclusion, and our strong recommendation, that the  $K_u$  band be henceforth treated as the basic airborne radar wavelength, for all applications involving long-range ground mapping. Under extreme conditions, the range will be somewhat reduced compared to an equivalent X-band radar.\* This occasional disadvantage will be much more than offset by the immediate and certain gain in resolution. That is the most important, but not the

\*One must be very careful not to blame range deficiencies of new equipment - such as APS-48 - exclusively on attenuation, without checking against the known attenuation factors expressed in Tables 9-3, 9-4, and 9-5. Experience has shown that radar on a new wavelength with new components is likely to suffer for a while from other troubles also.

~~CONFIDENTIAL~~

~~SECRET~~

~~SECRET~~

~~CONFIDENTIAL~~

only, argument for the adoption of the  $K_u$  band; pertinent jamming considerations will be mentioned in Section G.

We further recommend vigorous development of components in the  $K_a$  band looking toward its use for high-resolution radar reconnaissance, especially from low-level high-performance aircraft. Finally, we believe the prospect of semiphotographic resolution, at relatively short ranges, by means of 0.35-cm waves, is bright enough to warrant research and development in this band. This recommendation is reinforced by our strong recommendation concerning passive microwave techniques (Chap. 10), since much of the development in the 0.35-cm band would be applicable to both problems.

We believe the time has come to treat the  $K_u$  band as the basic wavelength for airborne radar for long-range mapping.

We further recommend the development of the  $K_a$  band for future use where extreme range is not a requirement.

The 0.35-cm wavelength offers sufficient promise for relatively short ranges to justify vigorous research and development.

#### F. SIDE-LOOKING RADAR

The side-looking radar, exemplified in the APS-38 experimental set, will be known by now to most of the readers of this Report. To describe the system very briefly, a linear-array antenna, running lengthwise along the aircraft, sends out a fixed vertical fan beam approximately at right angles to the aircraft's course. This beam is scanned along the ground by the forward motion of the aircraft. The radar range sweep is recorded as a transverse trace on a slowly moving strip. In this way, a strip chart, in approximately true Cartesian coordinates, is generated so long as the plane flies a straight course. Means can readily be provided for stabilizing the data fed to the chart to remove the distortion that would be introduced by yaw of the plane. Pitch introduces only a minor error, and roll no error at all. Provision of a second antenna, looking out the other side, will permit the chart to include a strip of terrain of a width equal to twice the radar range.

From every point of view, future requirements for radar reconnaissance appear to demand high-resolution radar and high-performance aircraft. The side-looking radar development makes the combination really feasible for the first time. That is why we recommend so strongly that it be encouraged and expedited.

We do not intend to review here all details of the problem, but we should like to call attention to one or two advantages of the new technique that are not perhaps so widely recognized as they deserve to be. We shall then outline a specific proposal for side-looking reconnaissance radar designed for fighter-type aircraft.

One of the most interesting differences between the fixed-beam radar and the conventional revolving-beam radar involves the time distribution of pulses on a given target. The revolving-beam radar looks at the same target at well-separated intervals scattered over a period of time of the order of magnitude of the radar range divided by the plane speed - a matter of several minutes at the very least.

~~CONFIDENTIAL~~

~~SECRET~~

~~SECRET~~

~~CONFIDENTIAL~~

Echoes collected from the same target over this interval are not brought together in the same place, nor do we possess means for adding and averaging them over so long a time if they were. Therefore, we cannot make the most of the information we have. The fixed side-looking beam is on a given target only for a time equal to the beamwidth at the target divided by the plane's speed - a fraction of a second in a typical situation. But all the pulses on the target during this period contribute to the same spot on the record and can be effectively averaged together. With a pulse-repetition rate as low as 100 per second, for example, it is possible to have the equivalent of 50 to 100 pulses per beamwidth for the more remote targets. This means that side-looking radar, can, if necessary, operate at very much lower average power than a comparable revolving-beam radar, without running into difficulties in the matter of pulses-per-beamwidth. To put it another way, side-looking radar uses the radar information available much more efficiently than does, at present, conventional radar.

The side-looking radar antenna is much simpler, in some respects, than any scanning antenna. There seems to be a tendency to regard linear arrays as complicated, and as requiring extensive developmental work. Actually, the design of fixed waveguide arrays, and their construction, once designed, is the ultimate in simplicity - a pipe with holes. The radome problem is simpler, too, because it involves fixed cylindrical optics only. The usual radome problem, for a scanning antenna, is many problems in one. For side-looking radar, the relation of radome to antenna is fixed once and for all, and it is a particularly happy relation also, in that the waves travel almost perpendicularly through the radome. One must be careful not to let the fact that the APQ-7 antenna was used for the APQ-38 lash-up create the impression that the eventual side-looking antenna will be a tricky device. It can be the simplest microwave radar antenna ever flown.

The possibilities of the side-looking technique are most vividly apparent when we tackle the problem of the fighter-type reconnaissance aircraft. A narrow spar is an object that can conceivably be carried on a fighter, and in various ways. One simple and elegant solution is to mount the spar on the nose of the fighter, as in Fig. 9-1, with the rest of the radar gear carried within the nose directly behind the antenna. We propose, as a modest but effective beginning, a spar  $8\frac{1}{2}$  to 9 feet long by 7 inches outside diameter, containing an 8-foot linear array to operate on  $K_u$  band or perhaps also, eventually, on  $K_a$  band. This antenna, used at 1.8 cm, would give a beam of width practically the same as that of the APQ-7 beam at 3.2 cm, a little under  $0.5^\circ$ . Its gain would be 60 per cent greater than that of the APS-48 system, for the same vertical pattern. Actually, there would be two such antennas within the spar, one looking right and one looking left, with a switch to connect the antennas alternately to the radar transmitter.

A cross section through the proposed spar is shown in Fig. 9-1(d). The vertical aperture available for each antenna is twice as great, relative to the wavelength, as that in the APQ-7 antenna, and there should be no difficulty in shaping the beam properly. The design of this antenna presents no new electrical problems - indeed, it eliminates many old problems. The radome, a fiberglass cylinder possibly, is integral with the antenna, and the whole interior of the pipe can be sealed and pressurized. There is room for a refueling pipe down the center of the structure, if that should be indispensable. Mechanically, the spar does not

~~CONFIDENTIAL~~

~~SECRET~~



~~SECRET~~

~~CONFIDENTIAL~~

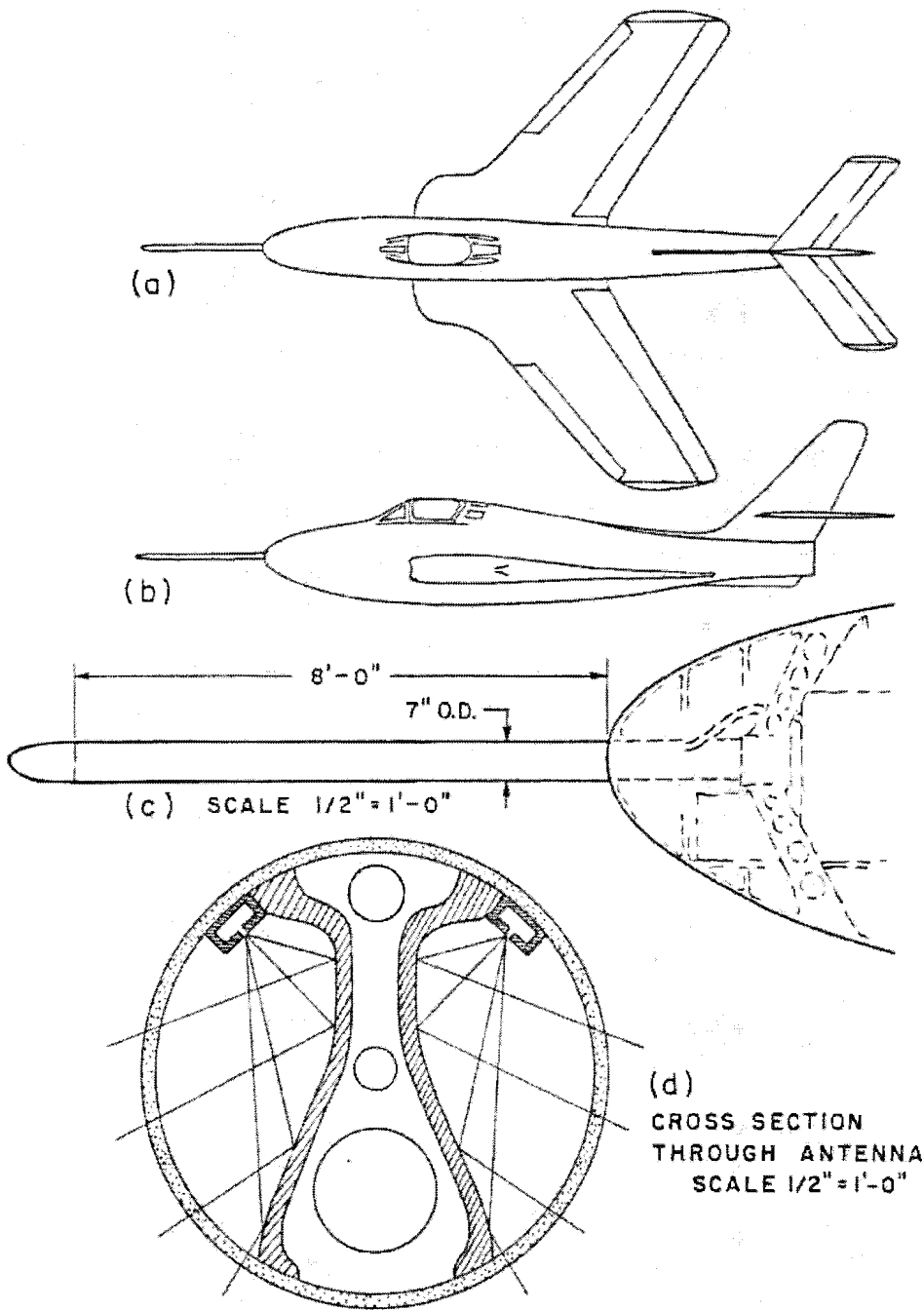

Fig. 9-1

~~CONFIDENTIAL~~

~~SECRET~~

~~CONFIDENTIAL~~

~~SECRET~~

appear to pose a very difficult problem. Aerodynamically, it is at least not preposterous, and the preliminary opinion of those concerned with such problems is that the effect will not be serious.

The radar transmitter, receiver, and strip recorder are contained in the nose. In fact, the nose assembly as a whole might well be interchangeable with other reconnaissance noses. The radar equipment, exclusive of spar, should not have to weigh more than 150 pounds; if necessary, the average power demand can be reduced by taking advantage of the low pulse rate permitted in a side-looking radar. The primary function of this radar is the generation of the strip chart. The radar must be designed to run unattended. Whether the pilot needs or can use an auxiliary radar indicator, we cannot foresee.

In recommending that this development be undertaken, we have in mind two goals. First, the development of a specific system, for an application to which the new technique is uniquely suited, will focus attention and effort as will nothing else. Second, and more important, the development can provide the Air Force, and fairly soon, with a real capability for radar reconnaissance with fighters.

We recommend the vigorous development of a simple high-resolution side-looking radar for nose installation in fighter-type aircraft.

#### G. SOME REMARKS ON JAMMING

There appear to be two extreme views on the susceptibility of present radar to jamming. The recent tests, in which the APS-23 was blanketed by a high-power, narrow-beam jammer steered onto the radar by an SCR-584, are interpreted by some as showing how easy it is to jam and by others as showing how hard it is to jam. We want to point out here that, however the problem is viewed, a careful analysis brings one to about the same conclusions as to what ought to be done. We have already argued, without reference to the jamming problem, that shorter wavelengths, high-resolution radar, and, in particular, side-looking radar for reconnaissance, ought to be the main lines of future development. Let us assume that it is important to reduce vulnerability to jamming, and see how these recommendations look in that respect.

- (1) Shorter wavelengths: - SAC has operated on the same radar frequency for 8 years. It is one band in which the U. S. S. R. is well supplied with prototypes. If they are prepared to jam us anywhere, they are certainly prepared at X-band. A switch to  $K_u$  would at least avoid handing them everything on a platter. Possibly they have already developed equipment on  $K_u$  (our ECM program certainly does not reflect this possibility!); but even if they have, the shorter wavelength is definitely disadvantageous to the jammer. The radar beam is narrower and it is easier to reduce the minor lobes that arise from multiple reflections within the radome and that offer the jammer his best opportunity to blind the radar when the radar is looking the other way.
- (2) High resolution: - Any increase in resolution makes jamming more

~~CONFIDENTIAL~~

~~SECRET~~

~~SECRET~~

~~CONFIDENTIAL~~

difficult by increasing the ratio of the gain in the beam to the gain in all directions.

- (3) Sidelooking: - Side-looking radar has two special advantages against jamming. First, it does not advertise its presence long ahead of time, but passes suddenly and briefly over a given spot. This means that it cannot be effectively jammed "on the beam" except by a continuous string of jamming stations. Second, the long fixed array lends itself ideally to the reduction of minor lobes, a reduction that, once achieved, can be maintained because of the fixed relation of radome to antenna. This makes it much harder to jam "off the beam".

We believe that progress along these lines will go much farther to reduce the jamming threat than any desperate alteration of the X-band equipment. In particular, we regard the development of high-power tunable X-band systems as a very poor remedy, a very costly remedy, and a development that, by its inherent complication of equipment and emphasis on the wrong things, will do more to set radar back than to advance it.

The recommendations advocating use of shorter wavelengths, increased resolution, and side-looking radar will all serve to lessen the vulnerability of radar to jamming.

#### H. STRIP RECORDING FOR RECONNAISSANCE RADAR

If the possibilities of side-looking radar for reconnaissance are to be fully exploited, there will need to be some development of appropriate methods for recording the radar information as a strip map. The problems involved have already been recognized by those who have been concerned with the APQ-38 development, and there appears to be no serious technical obstacle. One rather straightforward solution to the problem is available: a continuous-strip photograph of the face of a cathode-ray tube upon which is painted the electron beam - a single intensity-modulated trace. In this scheme, the stabilization of the data against aircraft yaw is easily accomplished by an electronic tilting of the trace. An advantage of the photographic link over other presently available means is the wide dynamic range available, which should make it possible to record the full radar information without manual gain adjustments. It appears that the resolving power of the photographic film is admirably matched to the recording requirements that would be presented by a side-looking radar of extremely high resolution. In particular, a 70-mm film will be capable of recording faithfully all the information that even a rather advanced type of side-looking radar can provide. In some cases, it might be desirable to include rapid processing of the film as part of the automatic recording system.

The requirements placed on the cathode-ray tube for this application are not the conventional ones. In particular, we require sharp focus in one direction only - the direction parallel to the trace - since it would be possible to shrink the other dimensions of the recorded spot by appropriate optics or by a mask. It may therefore be feasible to achieve higher range resolution than would be possible in a normal PPI. It is even conceivable that a flat cathode-ray tube could be used here to some advantage, although any possible advantage would

~~CONFIDENTIAL~~

~~SECRET~~

~~CONFIDENTIAL SECRET~~

have to be weighed very carefully against the obvious disadvantage of a new tube type.

What is really needed is a well-thought-out development of a complete recording system in which the video-response law, the electron optics of the cathode-ray tube, the recording camera with its drive and (possibly, with the extra feature of immediate processing), will be matched to one another.

The realization of the advantages of side-looking radar depends on parallel integrated development of the methods of strip mapping, including a sharper-focus cathode-ray tube and automatic recording equipment.

#### I. FORWARD-LOOKING HIGH-RESOLUTION RADAR

It is evident to us that the side-looking radar already described will produce great advances in the ability of radar to gather intelligence-bearing information; however, it is not now self-evident that the side-looking radar will meet the requirements that exist for a bombing set. If forward-looking radars continue to be required, we must face the problem of obtaining higher resolution in order to increase their intelligence-gathering ability - which is synonymous with improved bombing accuracy. The over-all recommendation is that it be clearly recognized that improved resolution requires more horizontal antenna aperture as well as, perhaps, the use of shorter wavelengths in the radar itself. Circuit complexity, as represented by the monopulse resolution improvers, is at best a means of making the most of an unsatisfactory situation with regard to antenna beam resolution.

Looking at the problem generally, we may ask whether the radar antenna requirements are inconsistent with the airplane. For significant improvements in radar resolution, an antenna aperture having a dimension on the order of 8 or 10 feet horizontally, and on the order of 8 inches vertically is required. It seems clear that the airplane itself has dimensions that are greater than this; therefore, there is no obvious inconsistency. For the same resolution, an antenna that scans through the full 360° necessarily makes a much greater demand on space in the aircraft. Thinking of the radar as a bombing instrument, one must keep in mind that the sacrifice in flexibility - in particular, the restriction to offset aiming points within the scanning sector - may be more than counterbalanced by that gain in resolution attainable with the larger section scanning antenna.

More specifically, let us consider the type of high-resolution scanning antennas that might be employed. The line-feed type antenna represented by the World War II Eagle (eventually embodied in APQ-7) was originally conceived as being installed in the leading edge of the airplane wing. This still seems like a very good idea. In the case of airplanes with the sweptback-type wing, it would be desirable to have such an antenna in the leading edge of both wings, and there seems no obvious reason why this also is not a possibility.

It is recognized that line-feed antennas that scan (e. g., the Eagle) are very difficult to build and will scan over a limited angle only. The Eagle antenna at X-band scanned an angle of 60° and, therefore, we might assume that a 1.8-cm version of the Eagle antenna might scan an angle of 30°. In the sweptwing installation, this may be entirely satisfactory, but improved antennas are needed.

~~CONFIDENTIAL~~

~~SECRET~~

~~SECRET~~

~~CONFIDENTIAL~~

It is suggested that the antenna sketched in Fig. 9-2 would be easier to build than the Eagle antenna, would operate over a broader frequency band, and might be adapted to scanning a larger angle. The antenna shown is an adaptation of the "Rocking Horse" antenna which has seen wide Service use. It embodies a horn feed, a parabolic reflector, and an emitting aperture which might be shaped somewhat to approximate the desired vertical beam distribution. The polarization of the electric field is parallel to the wide dimension of the antenna, and, therefore, supporting struts might be placed at frequent intervals across the aperture as well as across the pillbox itself. Two alternate methods of scanning are suggested by the section drawings of Fig. 9-2. In 9-2(a), the entire parabolic surface and a portion of the top and a portion of the two sides of the pillbox are moved in the plane of the wide direction of the antenna. Energy would not be expected to pass through the opening because the gap forms a waveguide beyond cutoff for the polarization employed (horizontal, as the antenna would be used). In the arrangement sketched in Fig. 9-2(b), only the parabolic surface would be rotated in the horizontal plane. Again, the energy would not be expected to leak past the parabolic reflector since there would be formed a waveguide beyond cutoff. We are informed that the antenna of Fig. 9-2 would fit into the wing of a B-36, for example.

It is recommended that a scanning antenna of the type sketched in Fig. 9-2, or of any other type permitting a comparable aperture, be developed for high-resolution forward-looking airborne radar.

It is further recommended that the radar antenna be regarded as one of the essential components of the aircraft, in much the same way that the gasoline tanks are now considered. Specifically, we emphasize the need for integral design of airframe and antenna. The radar antenna of adequate aperture is an essential to bombing accuracy just as a gasoline tank of adequate volume is essential to flight over the required distance.

High-resolution, forward-looking scanning radar can be designed for modern bombers if a determined effort is made. Provision for the antenna of such a system must be integrated with airframe design.

#### J. GROUND MAPPING BY DOPPLER ANALYSIS

A novel and extremely promising method for obtaining a radar map of very high resolution has been discovered in the course of work on airborne moving-target radar at the University of Illinois. The method has been described to the BEACON HILL Study Group by Dr. Chalmers Sherwin. In this scheme, a very broad microwave beam is directed at a fixed angle of some 30 or 40 degrees with respect to the aircraft's heading. The transmitter and receiver operate as in a conventional pulse radar, but the pulse duration is quite short and the pulse-repetition rate is higher than usual. A narrow range gate selects returns at a discrete range only. The effective echoing area, at any instant, is a curved strip or arc, defined by the range interval selected and the angular width of the beam. Ground targets lying at positions within this arc are distinguished from one another by their Doppler frequencies. A series of audio filters, in effect, divides the arc into many small angular increments. Frequency discrimination, in other words, is made to serve the purpose of angular discrimination. As the plane moves, the arc is swept along the ground, and, by means of a suitable strip recorder, a

~~CONFIDENTIAL~~

~~SECRET~~

~~SECRET~~

~~CONFIDENTIAL~~

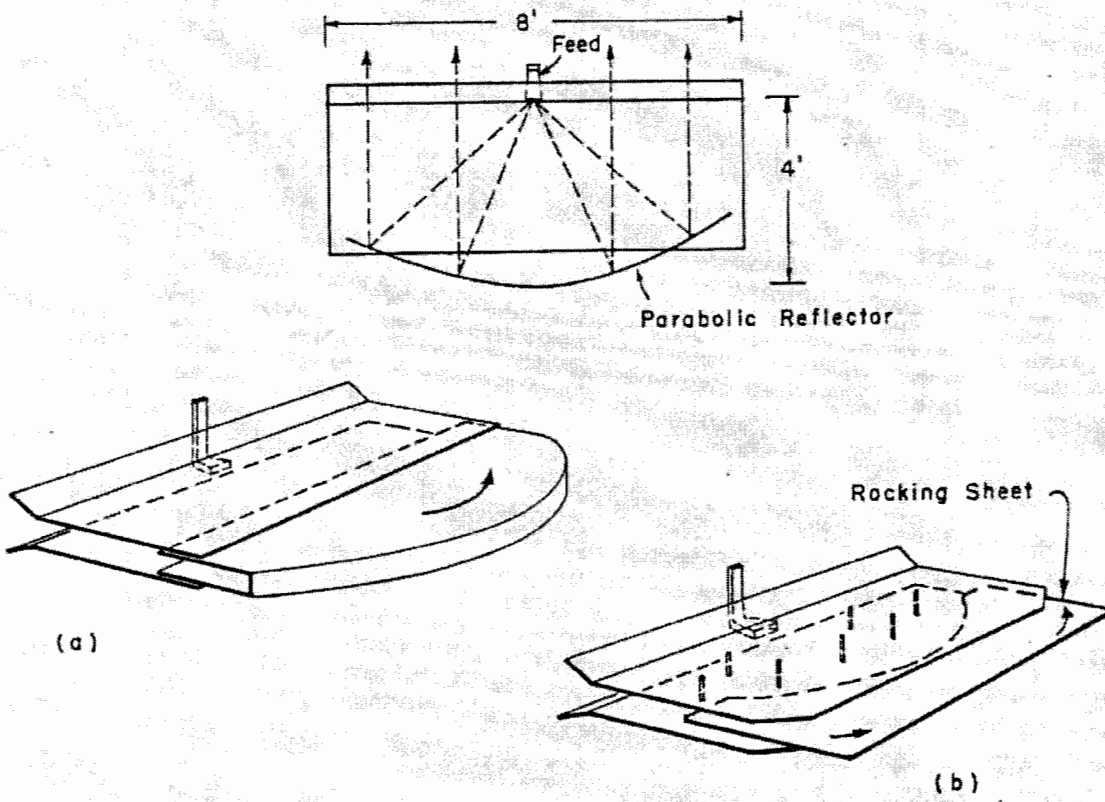

Fig. 9-2

~~CONFIDENTIAL~~

~~SECRET~~

~~SECRET~~

~~CONFIDENTIAL~~

strip map is generated whose final appearance should in most respects resemble the strip map generated by a side-looking radar. This is a very inadequate explanation of the proposed device, and hardly does justice to its ingenuity. Since complete details are available in a recent report by Sherwin,\* we prefer to limit the discussion here to the relation of this proposal to the other developments we are recommending.

For low-level radar reconnaissance by fast small aircraft, the Doppler method is extremely attractive. The range of the system is limited in a way that ordinary radar is not and, although this limitation may be circumvented by further elaboration of the system, it appears that a range of 5 to 10 miles is about the most one should count on now. We have already argued that there is an important use for relatively short-range reconnaissance radar, providing it has extremely high resolution and can be carried in a small high-speed plane. We therefore strongly recommend that the development of the Sherwin system be carried forward.

However attractive the proposed scheme may be, we do not believe that it removes the need to proceed also with the development of the high-resolution side-looking reconnaissance radar. Side-looking reconnaissance radar has, at present, two important advantages that we cannot afford to throw away. It is not subject to the peculiar range limitation of the Doppler method, and it is a combination of known, proven, and simple elements that will give us a high-resolution radar now. Enthusiastic as we are about Sherwin's proposal, we feel that it would be most unfortunate if it were treated as an excuse for once more postponing a direct attack on the problem of high-resolution radar for reconnaissance.

---

\*C. W. Sherwin, High-Resolution Airborne Radar Employing Doppler Frequency Analysis, Control Systems Lab., University of Illinois(Contract DA-11-022-ORO-174), 24 March 1952.

~~CONFIDENTIAL~~

~~SECRET~~

~~SECRET~~

~~CONFIDENTIAL~~

CHAPTER 10

PASSIVE INFRARED AND MICROWAVE RECONNAISSANCE

A. INTRODUCTION

A spectacular new technique for aerial reconnaissance is on the threshold of practicality. This technique involves the reception of thermal electromagnetic-wave radiations from objects, without the use of transmitted power at the sensing device. Most outstanding among the potentialities of this technique is its ability to "see" through clouds and at night. What is "seen" may approximate a crude optical picture far more closely than does radar information.

B. THE PHYSICAL EFFECTS INVOLVED

The elementary concept involved in this technique is the measurement of the apparent radiation temperature of an object. This type of measurement has been made by K. G. Jansky, H. T. Friis and C. B. Feldman in connection with radiation from objects in space, by G. C. Southworth in connection with sun-noise measurements, and by R. H. Dicke at the M. I. T. Radiation Laboratory in connection with atmospheric-absorption measurements.\* Figure 10-1 shows a simplified block diagram of a receiver. The temperature  $T_1$  at the receiver is compared to that of the absorbing body B which is at  $T_2$ , and the difference signal is shown at the indicator. When body B is perfectly absorbing at the wavelength used and is large enough to intercept the entire antenna beam, the receiver indicates the temperature difference  $(T_2 - T_1)$ . If, however, body B is totally reflecting (as is metal at radio wavelengths), the energy received by the antenna is that from the surrounding region A which is presumed to be completely absorbing (see Fig. 10-2). In this case, the receiver will indicate  $(T_3 - T_1)$  even though it is directed at body B which is at temperature  $T_2$ . These simple cases illustrate that three important factors determine the apparent temperature of an object:

- (1) The temperature of the object;
- (2) The emissivity (or reflectivity) of the object;
- (3) The temperature of the absorbing medium surrounding the object.

On a clear day, the temperature of outer space, as seen by an infrared receiver in the 8 to 15 micron region, is low - probably less than  $100^\circ$  K. In most of the microwave spectrum, the temperature of outer space may be  $10^\circ$  or  $20^\circ$  K. Clouds attenuate infrared waves but not microwaves, and interfere with infrared reconnaissance but not with microwave reconnaissance. Hence, when viewed by an airborne receiver, smooth bodies of water, metal roofs, and other highly reflecting objects will have a low apparent temperature. Other materials absorb energy to a greater extent, and take on an apparent temperature T of:

\*See, for example:

R. H. Dicke, Atmospheric Absorption Measurements with a Microwave Radiometer, Phys. Rev. 70, 340 (1946); The Measurement of Thermal Radiation at Microwave Frequencies, Rev. Sci. Inst. 17, No. 7 (1946).

Final Report of PROJECT VISTA, Chapter 9, Section 9F, "Passive Infrared Devices for detection and Guidance"; also Chapter 8, Appendix VIII C, "Tactical Uses of Infrared."

~~CONFIDENTIAL~~

~~SECRET~~



~~SECRET~~

~~CONFIDENTIAL~~

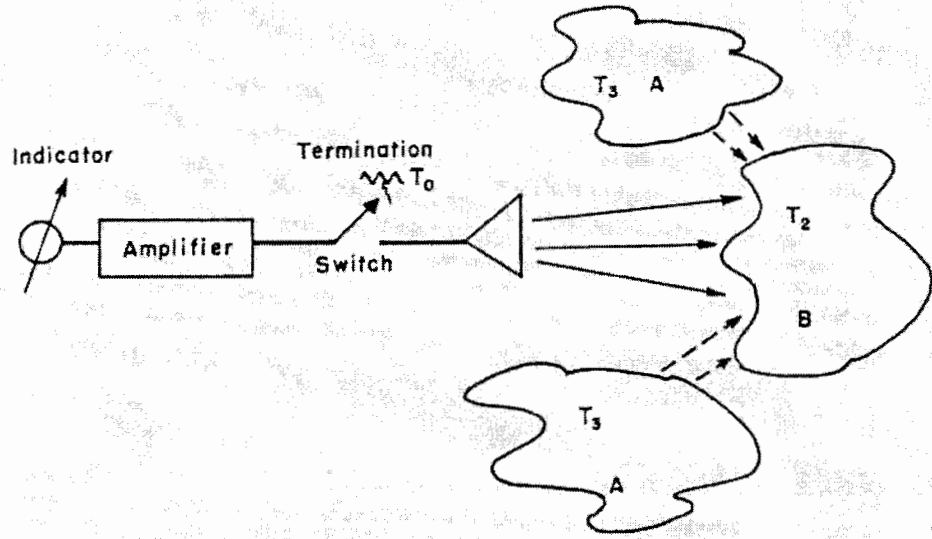

Fig. 10-1.

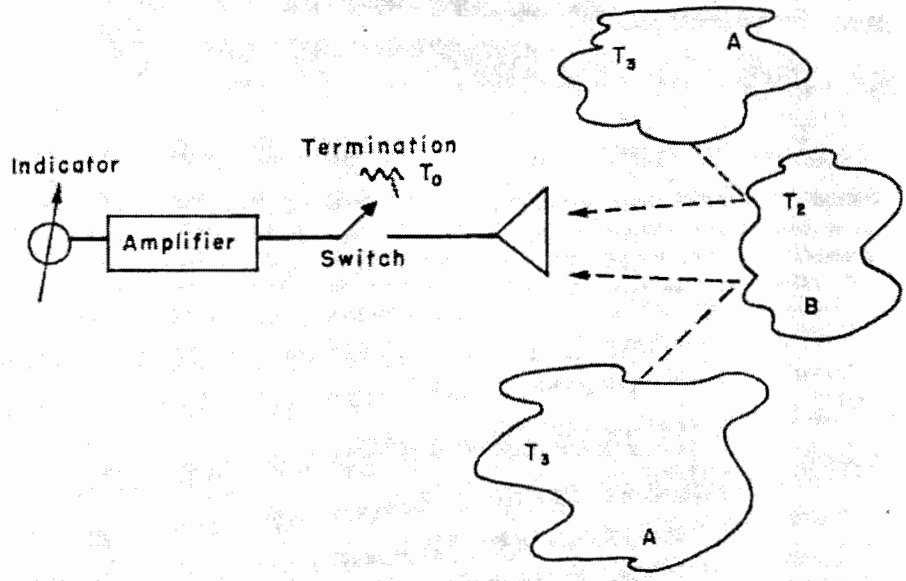

Fig. 10-2.

~~CONFIDENTIAL~~

~~SECRET~~

~~SECRET~~

~~CONFIDENTIAL~~

$$T_a = \epsilon T_2 + (1 - \epsilon) T_3$$

where  $T_2$  and  $T_3$  are the temperatures of the object and its surroundings, respectively, and  $\epsilon$  is the emissivity of the object. A typical temperature for objects on the ground is 290° K and emissivities are perhaps on the order of 0.5. Thus apparent temperature differences on the order of 100° K or more are expected to exist in typical ground terrain when viewed from the air, even though the true thermal temperatures of objects on this terrain are almost the same. A few cases may occur wherein an object is at a truly elevated temperature and simultaneously is highly absorbing (or highly emissive, which is the same thing) at the wavelength employed; only in such rare cases will the system act as a heat detector. Most apparent temperature differences will be determined by differences in emissivity or reflectivity and the low temperature of outer space.

The next expectation is that rivers, land, and objects on the land will have widely different apparent temperatures. By observing these temperature differences and recording them as brightness variations on a film or cathode-ray tube, we obtain a picture that is a reasonable substitute for a visual picture.

### C. PASSIVE INFRARED RECONNAISSANCE

While investigating the ability of infrared radiations from ground objects to trigger a camera system for night photography, scientists of the Servo Corporation of America noted rather appreciable radiation differences. They thereupon recognized potentialities of the thermal-radiation receiver for aerial surveying, and they converted the system to make it scan in the manner sketched in Fig. 10-4. The scanning system had a resolution of  $0.5^\circ \times 0.5^\circ \times 0.5^\circ$ , and swept an angle of  $60^\circ$  total at right angles to the direction of aircraft flight. Scan rates on the order of 2 to 6 per second were employed; thus 240 to 720 elements were scanned per second. With 2 channels - i.e., 2 scanning beams and 2 completely separate receivers, separated by  $1^\circ$  in the direction of flight and synchronized with regard to lateral sweep - the information rate was doubled. The forward motion of the aircraft produced the second dimension of scan and the pictorial display was created by synchronizing the motion of a paper recording chart with the forward motion of the airplane. A 12-inch diameter antenna dome was employed.

Wavelengths in the region 8 to 15 microns were used, for this is the region in which the atmospheric absorption is quite low.\* A silver chloride filter was used in the receiver to block off wavelengths below 0.7 micron in order to exclude the large visible reflections that are not usable for the purpose of intelligence. The detection element employed was a thermistor which has a much broader band than that from 8 to 15 microns. A thermistor time constant on

\*For the region below 8 microns, Dr. Ovrebo briefed the BEACON HILL Study Group on the use of the near-infrared radiations for the detection of tanks and other objects. We do not know of an interest in the near-infrared for the pictorial display of terrain features; and, without giving detailed consideration to the problem, we expect that the 10-micron region is a better choice. The transmission loss through clear atmosphere in the vicinity of 3.5 microns may be lower than in the band near 10 microns, but the 3.5-micron pass band is narrower. The near-infrared wavelengths would be just as subject to overcast and cloud attenuation as are 10-micron radiations. A detailed discussion of the use of near-infrared in connection with TAC problems is given in the Report of PROJECT VISTA.

~~CONFIDENTIAL~~

~~SECRET~~

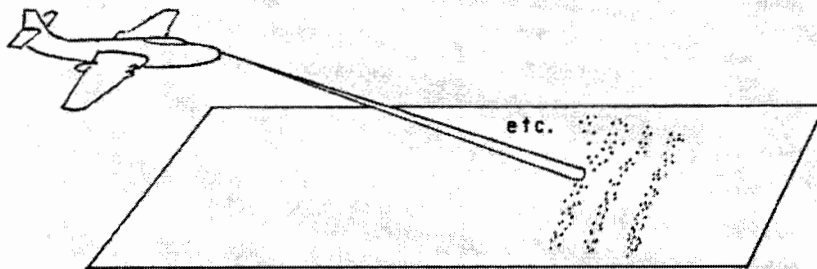

Fig. 10-3

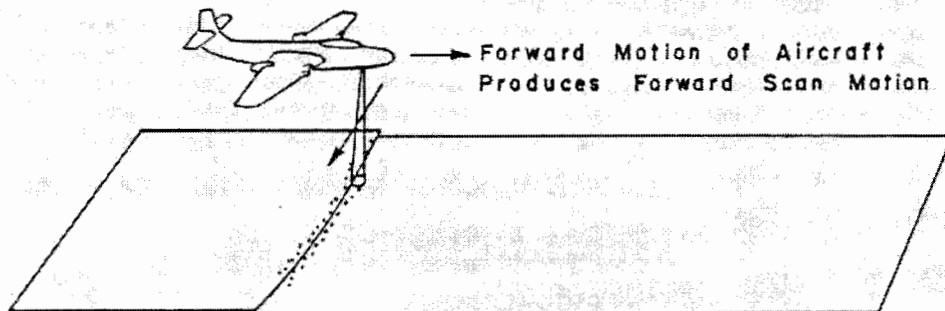

Fig. 10-4

~~SECRET~~

~~CONFIDENTIAL~~

the order of 0.003 sec was employed in the system, and the present technique for making thermistors limits the time constant to the order of 0.001 sec minimum.

An indication of the strength of the signals received during flight tests is given by Table 10-1.

TABLE 10-1	
Magnitude of Signal at a Reference Point in the Receiver	
<u>Signal Source</u>	<u>(Microvolts)</u>
Total (set and thermal noise)	5
Hangar area	30 - 90
Small factory	250
Burning trash dump	1000

These data indicate that moderately small objects produce signals well above the noise level, and that the dynamic range of the recording mechanism should be about 40 db in order to make full use of the available information.

The aerial survey of the New York area made with this equipment by the Servo Corporation reveals that a tremendous amount of detail is available. The day and night recordings of the same area were noticeably different. In particular, at night certain highways appeared brighter than the surrounding terrain, whereas in the daytime they appeared darker. This may be due to the fact that the highway signal remains constant, while the signal from the surrounding terrain fluctuates widely. This general behavior is probably inherent in the use of the 8 to 15 micron region, and has an important bearing on the significance of the information - namely, that the information received from a given area will depend appreciably upon the time of observation as well as upon absorption conditions in the atmosphere above the target.

There is a serious atmospheric propagation problem in the 8 to 15 micron region. Rain clouds of sufficient density are certain to produce high attenuations and, therefore, will screen an airborne infrared receiver from all ground objects (if the cloud is between the receiver and the ground). This may be the outstanding reason for seeking a thermal-radiation receiver that operates at short radio wavelengths, where clouds have relatively little effect. The infrared, however, is reported to have a noticeable edge over optical wavelengths with regard to seeing through overcast, and this is to be expected from the nature of absorption effects.

#### D. PASSIVE MICROWAVE RECONNAISSANCE

Although proposal for the use of microwave frequencies in a thermal-radiation receiver system was made\* and specifications for a proposed development contract were drawn

---

\*Craven, W. A., Jr., and Genoud, R. H., Detection of Thermal Radiation at Microwave Frequencies, Hughes Aircraft Company Report, Feb. 8, 1951.

~~CONFIDENTIAL~~

~~SECRET~~

up,\* no further progress appears to have been made.

1. The Receiver

We consider first the sensitivity that might be expected of a microwave thermal-radiation receiver. The work of R. H. Dicke has been interpreted to show that the smallest observable temperature difference  $\Delta T$  is related to the parameters of the receiving system as follows:

$$t \Delta f \left( \frac{\Delta T}{FT} \right)^2 = 1 .$$

where

- t = averaging time for the measurement in seconds,
- $\Delta f$  = receiver intermediate-frequency bandwidth in cycles/sec,
- $\Delta T$  = observed temperature difference,
- F = receiver noise figure,
- T = absolute temperature at receiver (approximately 300°),

The smallest observable temperature difference is here defined to be equal to the rms statistical fluctuation in apparent temperature, which one might call the "background noise".

From this relation, it can be seen that the figure of merit of the receiver is

$$\frac{\sqrt{\Delta f}}{F} .$$

Both bandwidth and noise figure aid in detecting the temperature difference. The frequency of operation does not enter directly into the receiver figure-of-merit relation. However, there are important factors that dictate the use of the highest possible radio frequency.

(a) In order to get the best resolution, we need the smallest antenna beam possible; with the limitations on antenna size inherent in airborne applications, this means we must use highest possible frequency.

(b) The size of many objects that we wish to detect on the ground is smaller than the cross-sectional area of the antenna beam at distances of about 40,000 feet, and, therefore, the actual signals delivered to the receiver will be largest when we use the smallest possible beam. This is a consequence of the fact that the receiver will "see" a temperature that is the average temperature over the entire cross-sectional area of the beam.

We must avoid significant atmospheric absorption in order to avoid attenuation of the signal and in order to take advantage of the low surrounding temperature of outside space. Therefore, we must certainly avoid the oxygen-absorption region near 5 mm. Wave-

\*Wright Air Development Center, Weapons Components Division, Exhibit No. WCER-139, dated 16 January 1952.

~~SECRET~~

~~CONFIDENTIAL~~

lengths longer than 6.5 mm will probably be satisfactory from the standpoint of absorption, with the possible exception of the region near 1.3 cm. where there is a water-vapor absorption band.

Let us consider the kind of receiver that is now available in the region between 6.5 and 10 mm and determine how much area can be scanned in a given time. Using components available on a research basis, we can build a superheterodyne receiver having a 20-Mc bandwidth and a noise figure of 15 db. It follows that temperature differences as small as  $10^{\circ}$  K can be measured at the rate of 22 elements per second (where an element is the area included within the beamwidth). Use of two polarizations or a multiplicity of receivers would increase this information rate. The effect of the image band has been included.

In order to evaluate the long-term implications, suppose we now consider the kind of receiver that might be made available after some years of research and development. It is likely that traveling-wave tubes will ultimately provide the best figure of merit as defined by the relation given above. Traveling-wave tubes that operate over a 3:1 frequency ratio have already been built. This means that a tube having a top frequency of 46,000 Mc, corresponding to a wavelength of 6.5 mm, would have a lower frequency limit of 16,000 Mc and a total bandwidth of 30,000 Mc. Traveling-wave tubes have also been built for the region around 3000 Mc (mid-band), with a noise figure of about 10 db. Suppose that we now assume that further development in the millimeter-wave region makes available tubes with noise figures of 10 db. We then find that we can measure a temperature difference of  $10^{\circ}$  K at a rate of 90,000 elements per second.

## 2. The Size of the Area Scanned

Consider first the line-scan system of Fig. 10-4. Assume a  $0.25^{\circ}$  antenna beamwidth (this requires an antenna about 7 feet in diameter), a 40,000-foot altitude and a 600-mph aircraft speed. The size of the element of area that is resolved directly beneath the airplane is 200 feet in diameter. The forward motion of the vehicle is about 1000 feet per second, or 5 elements of area per second. The transverse motion of the beam must then be 5 one-way sweeps per second, and 5 elements of area or a 1000-foot wide strip may be examined by the 22 elements-per-second receiver discussed above. A very modest portion of the foreseeable receiver improvement would make possible the scanning of an area 2 or 3 miles wide.

If the forward motion of the aircraft causes the scanned area to move past the receiver (Fig. 10-3), a total of 5 elements may be continuously examined. Arranged in a square picture, this means that an area about 1000 feet square with a resolving power of 400 feet could be examined with the "existing" set.\* If the beam scan is arranged so as to track a given area on the ground as the aircraft approaches the target area, then the full 22 elements per second measuring time could be utilized, corresponding to an area approximately 2000 feet square for the parameter values selected above. By taking longer than a second for the measurement or by using more bandwidth, more elements may be utilized (in direct proportion to the increase in bandwidth or increase in time of measurement). Again, a rather modest portion of the foreseeable improvement in the receiver would make available an area several miles on a side instead of the 0.4-mile square area indicated above.

\*This assumes an angle of  $26.5^{\circ}$  between the scanning beam and the horizontal.

~~CONFIDENTIAL~~

~~SECRET~~

~~CONFIDENTIAL SECRET~~

### 3. Stability of Microwave Thermal Signals

The best way to learn about the stability of microwave thermal signals is to observe them, and we propose that this be done. In the meantime, we may try to anticipate the results.

It is very likely that there will be no day-to-night variation in the observed signals, since true temperatures are not expected to play a large part in the contrast between various objects. Similarly, overcast should not influence the picture materially. The sun should influence the picture only in the rare case where its mirror image appears at the receiver.

It is quite possible that a recent rain will alter the reflectivity of objects enough to change the picture, and there may be seasonal differences due to growth of vegetation, freezing of rivers, snow, etc.

The best evidence on this subject, we repeat, is experimental evidence.

### 4. Other Applications

It should be noted that a microwave thermal system may offer advantages to ground-based operations as well as to the airborne aerial operations we have been considering. In particular, it is quite likely that a ground-based receiver can detect airplanes by virtue of the fact that radiation from the earth is reflected from the under side of the airplane toward the receiver. The radiation from the earth would be relatively large compared to that from the cold space bordering the airplane as viewed from the receiver.

It is also quite possible that tanks or other vehicles might be detected by the passive-radiation receiver because the tanks have higher reflectivities than bushes or other foliage that might be in the background.

These speculations are subject to evaluation by means of very simple experiments.

## E. DISCUSSION AND CONCLUSIONS

### 1. Passive Infrared Reconnaissance

A very interesting piece of work has been done on the use of infrared thermal-radiation reception as a pictorial display system; this amounts to a slow television viewing system in which optical wavelengths have been replaced by infrared wavelengths. Two major shortcomings have appeared: (a) the picture received in this manner varies greatly between day and night; and (b) the utility of the system is limited by clouds and atmospheric conditions although this limitation is not so severe as it is at visible wavelengths (photography). In addition, it is not now possible to build a really fast-acting infrared radiometer (to produce essentially continuous viewing of an entire area) because there is not available a really fast-acting infrared detector. On the other hand, the infrared system has the tremendous advantage of existence.

It is recommended that the existing infrared equipment be used to determine the basic characteristics of airborne infrared reconnaissance.

~~CONFIDENTIAL~~

~~SECRET~~

~~SECRET~~

~~CONFIDENTIAL~~

In particular, a serious attempt should be made to obtain quantitative information on the transmission losses through various types of clouds viewed from various altitudes, and to determine how frequently an infrared thermal-radiation receiver would be rendered inoperative by clouds or by rain conditions. Flights should be made at high altitude to demonstrate the kinds of pictures that can be obtained under these conditions for comparison with the pictures that have already been taken at low altitudes. An attempt should be made to ascertain the relative importance of absolute temperature and emissivity in determining the intensity of infrared radiation received from various objects. While carrying out this study, consideration should be given to the type of signal that probably would be received by a microwave thermal-radiation receiver in similar circumstances. The objective would be to try to determine the areas of application in which the infrared system performance would clearly equal or excel that of the microwave equivalent. It has been suggested, for example, that factory gases may give a positive indication on the infrared radiometer, but no indication on a microwave radiometer.

Until some preliminary work has been done on passive microwave reconnaissance, and some of the work recommended in the above paragraphs is carried out, it is suggested that no new infrared thermal-radiation-reception equipment be developed for reconnaissance purposes. This recommendation does not apply, of course, should there be discovered an application that is clearly not met by the proposed passive microwave system.

#### 2. Passive Microwave Reconnaissance

It is possible to build receiving equipment capable of detecting the differences in apparent thermal radiation that are expected to emanate from buildings, trees, rivers and land in the short-wavelength end of the radio spectrum.

If such receiving equipment were used to actuate a pictorial display system, it is quite probable that the picture would be informative as to the nature of the terrain. It is certain that such a picture would differ from the corresponding one obtained at infrared wavelengths (since the emissivity of many materials differs greatly at the two widely different wavelengths); it would also differ materially from a radar picture.

In order to realize 0.5" resolution, the microwave system will require a 3.5-foot aperture, whereas the infrared system employs only a one-foot aperture. The beam angle can be reduced by increasing the antenna aperture in the microwave case; in order to reduce the beam angle in the infrared system, it is necessary to reduce the size of the thermistor detector, for this is the limiting element in the present equipment.

Compared to the infrared system, the outstanding advantage of the microwave system is greatly reduced susceptibility to cloud interference. The microwave system may also become faster than the infrared system, and capable of simultaneously viewing more elements, when foreseeable improvements in receivers materialize.

The potentialities of the microwave system appear to us to be great, and it seems unfortunate that a year has passed since the initial conception without actual work being started.

We recommend that a vigorous exploration of the potentialities of microwave thermal-radiation reception be undertaken

~~CONFIDENTIAL~~

~~SECRET~~



~~CONFIDENTIAL~~

~~SECRET~~

immediately. This should take the form of observing the contrasts in apparent temperature that are presented to an elevated or airborne receiver by bare land, water, trees, cities, etc.

3. Airborne Passive Receivers versus Airborne Radar

The thermal-radiation reception system has the following advantages compared to radar:

(a) It does not advertise its presence (as does radar), because no transmitter is employed.

(b) It is probably impervious to jamming since: (1) very small side lobes can be realized in the sharp-beam antenna which has practical size in the millimeter region; and (2) the jammer is located with great precision by the nature of the system (the jammer will be a bright spot on the picture).

(c) The nature of the thermal-radiation receiver system is such that it will tend to show the true shape of buildings or other large objects. Radar, on the other hand, tends to show the sharp corners of objects rather than the true shape of the objects.

(d) The thermal system is at its best when it is looking straight down, whereas radar provides no information whatsoever when used in this way. (Airborne radar is virtually useless for viewing angles out to about 30° from the vertical, for there is very little range difference between objects on the ground plane in this sector.)

(e) By virtue of its resembling normal vision more closely than does radar, the passive display picture may be more easily interpretable than is the radar picture.

(f) There is no scanning loss associated with the passive-radiation receiver since the thermal radiations are continuous. Therefore, with a suitable integrating arrangement on the face of the cathode-ray tube or other viewing mechanism, it is quite possible to use a rapid-scanning presentation which allows the viewer to obtain the maximum of information from the system.

On the contrary side of the comparison, it is not clear that passive reception can provide enough sensitivity or resolution at large distances to replace radar as a bombing system. Passive receivers resemble low-resolution optical systems more than radar systems in this respect.

~~CONFIDENTIAL~~

~~SECRET~~

~~SECRET~~

~~CONFIDENTIAL~~

CHAPTER 11  
RECONNAISSANCE VEHICLES

A. THE NEED FOR RECONNAISSANCE

In the current world situation, the need for the sort of information obtainable through aerial reconnaissance is many times more urgent than it was before and during World War II. This urgent requirement for effective reconnaissance can be met only by a corresponding increase in the emphasis placed by the Air Force on the development and effective employment of aerial reconnaissance systems. Such systems must be designed to meet two rather different needs. Prior to the outbreak of acknowledged hostilities, it will be useful to supplement our present information on the Soviet economy, military capabilities, and order of battle - so far as this can be done - by up-to-date information gathered in politically acceptable ways. Should hostilities commence, we must be ready for an immediate and continuing reconnaissance effort conducted without regard for the political niceties prevailing earlier. The dual nature of the reconnaissance task for which we must develop equipment and systems suggest that, other things being equal, a system having both a pre- and a post-D-Day capability will be preferable to a pre-D-Day system whose utility is limited to that period.

In what follows, the general requirements for reconnaissance vehicles are sketched, and the recommended program is set forth in brief fashion. The recommendations are intended more to indicate the general shape and direction of a future program than to present an exhaustive and infallible analysis of desirable developments in reconnaissance.

B. CURRENT RECONNAISSANCE VEHICLES

Reconnaissance aircraft types now in service include the RB-26, RF-51, RB-29, RB-36, RB-45, RB-50, and RF-80. To these can be added the RB-47 and RF-84F, which will go into production this year. Many of the current reconnaissance types have been obtained by modifying for reconnaissance airplanes that had been made obsolete by a later model of the same type. Reconnaissance has often been forced to use the handed-down equipment of the combat branches of the Air Force.

The dangers inherent in this approach to reconnaissance have now been recognized. In the programs for the MX 1626 and MX 1712, the requirements for reconnaissance are being taken into account during the design stages. Nevertheless, to illuminate the reasons behind later recommendations in this Report, it may be useful to review here some of the major requirements applicable to the design of reconnaissance systems.

C. RECONNAISSANCE REQUIREMENTS

1. Need for Pre-D-Day Aerial Reconnaissance

We have reached a period in history when our peacetime knowledge of the capabilities, activities and dispositions of a potentially hostile nation is such as to demand that we supplement it with the maximum amount of information obtainable through aerial reconnaissance. To avoid political involvements, such aerial reconnaissance must be conducted either from vehicles flying in friendly airspace, or - a decision on this point permitting - from vehicles

~~CONFIDENTIAL~~

~~SECRET~~

~~CONFIDENTIAL SECRET~~

whose performance is such that they can operate in Soviet airspace with greatly reduced chances of detection or interception. The political obstacles to performing reconnaissance of the latter type are often mentioned as justifying a lack of effort on equipment and systems for pre-D-Day reconnaissance involving penetration of Soviet airspace. This is probably unwise. Without realistic trials of such systems against friendly air defense, without realistic evaluation of the reconnaissance information that such systems are able to gather in actual field experiments, we do not have all the facts that are needed to reach sound political decisions concerning the use of such systems.

### 2. Survival in the Face of Modern Defenses

The classical reconnaissance mission is performed by the swiftest means, whether the light-foot soldier, the cavalry, or the high-speed flying machine. In World War II, it was generally performed by a single aircraft, often unarmed, which relied on high performance to evade enemy defenses. The concept of using the fleetest means for reconnaissance is still sound. We know that Soviet interceptors compare favorably with the best we have; we suspect that their local ground-to-air defenses may also be formidable. Under these circumstances, we shall not wish to use obsolescent aircraft for reconnaissance.

Furthermore, the fuel and airframe weights necessary to fly the vehicle over long distances to the enemy airspace inflict a penalty on target performance, which should be avoided wherever possible by the use of peripheral bases and air refueling and parasiting facilities. The highest possible speed and altitude performance will be required of reconnaissance aircraft; a capability for obtaining information by low-altitude runs over the target is also important.

### 3. Balance in Reconnaissance System Design

High performance in aircraft carries with it ever-increasing penalties in terms of the ratio of gross weight to payload. Foreseeable supersonic speeds and long operating ranges will in some cases cause an increase in aircraft gross weight of more than ten pounds for every additional pound of equipment weight. This being so, it is of the greatest importance to minimize the size and weight of the sensing equipment to be carried by reconnaissance aircraft - maintaining, of course, performance adequate to obtain essential information - rather than to put costly or even impossible requirements on the airframe and engine designer for want of sufficient attention to the design of the payload. This has not always been done in the past.

Perhaps the greatest opportunity for better balance in reconnaissance system design is in electronic intercept installations in ferret aircraft. In Chapter 4, we have examined the several functions of electromagnetic intercept, and pointed out that the present electronic receiving equipment is aimed at the precise analysis of a limited number of signals. The complete installation needed for this fine analysis resembles a flying laboratory and requires a very large plane to carry it. Other important functions of electromagnetic intercept - particularly the effective surveillance of broad regions of the spectrum - could be served by less elaborate equipment, which would lessen the demand on aircraft gross weight.

In addition, it is operationally sound to design alternative equipment installations for the different types of reconnaissance missions (photographic, electromagnetic

~~CONFIDENTIAL~~

~~SECRET~~

~~SECRET~~ CONFIDENTIAL

intercept, high-resolution radar, etc.), rather than to overburden the reconnaissance aircraft in the hope of obtaining all types of data on a single sortie. Equipments designed to make special observations required only rarely in a campaign can be excluded from the standard systems design, with provision for alternate use when such special observations may be critically important. Again, data links and relay systems can be used, when their reliability is high enough, to permit simplification and weight saving in the airborne equipment.

The important consideration is to design the reconnaissance system as an integrated whole: vehicle, sensing equipment, and organization for reducing and distributing the data obtained. This process must begin at the inception of the basic aircraft type, whether bomber, fighter, or special vehicle. Whenever airframe and equipment are developed independently, there is a loss of over-all economy and good performance.

#### 4. Economy of Reconnaissance Types

For obvious reasons, it is best to have the smallest number of specialized reconnaissance aircraft types consistent with adequate accomplishment of the reconnaissance task. Three rather different capabilities appear important to us, particularly at the onset of acknowledged hostilities.

(a) Fighter or superior performance, primarily at high altitude, but with the ability to go down to low altitude near a target, out to radii as great as 1000 miles.

(b) High-altitude, high-speed performance in an aircraft capable of carrying a substantial payload (say 4000 or 5000 pounds) to radii up to 2500 miles.

(c) Limited-range (about 100 miles), very-high-speed performance at low altitudes, in a terminal missile that can be launched near a target. Reconnaissance data from such a missile would be relayed back to the launching aircraft.

In so far as possible, the first two of these aircraft types should be able to carry an installation of any important data-collecting equipment: day photographic, night photographic, high-resolution radar, electromagnetic intercept, passive infrared and microwave detection, specialized weather instrumentation, and so on. In the fighter type corresponding to (a), this is probably best accomplished by means of interchangeable noses containing different reconnaissance-equipment installations. For this reason, it is essential that the fighter-type reconnaissance airplane must not have an air intake in its nose. Either side air scoops or wing-mounted engines must be used.

The larger reconnaissance aircraft described by (b) will lend itself even more readily to alternate installations of different observing equipment. In the case of a modified bomber, interchangeable packages can be prepared for bomb-bay stowage; in later aircraft, detachable and interchangeable pods can be provided in other ways.

It is not required that the full gamut of instrumentation be provided for the terminal missile (c). The most important capability for this vehicle is that of photoelectric scanning of the target, with a radio data link back to the launching aircraft.

By no means all the wartime situations demanding special information will be met by the three equipment types recommended here; some situations, indeed, cannot even

CONFIDENTIAL

~~SECRET~~

~~SECRET~~

~~CONFIDENTIAL~~

be foreseen. It is felt, however, that the vast majority of the demands for strategic reconnaissance information can be met by the recommended types, and that the situations demanding other equipment will be so special that they can and should be met by special modifications of existing equipment.

#### D. A RECOMMENDED PROGRAM

In this section there is sketched a possible program aimed at improving the Air Force strategic and pre-D-Day reconnaissance capability in accordance with the general considerations that have been outlined. It is not claimed that the program recommended here is to be taken as final or ideal; other considerations, of which the BEACON HILL Study Group has been ignorant, may make modifications desirable. However, it is felt that the general outlines of the program are sound.

For convenience in discussion, two time phases are distinguished: the immediate time period, defined as extending from the present to 1956; and a future time period covering 1956-1960. Within each of these periods, a further distinction is drawn between a cold-war situation before D-Day, and the situation prevailing after D-Day.

The pre-D-Day reconnaissance vehicles considered in this section are intended principally for penetration to varying depths of unfriendly airspace; the vehicle requirements for border air surveillance from friendly airspace are generally less exacting, except for altitude perhaps.

##### 1. Pre-D-Day, 1952-1956

A high-altitude free balloon for pre-D-Day penetration is an extremely interesting and promising vehicle for a number of military and scientific uses, and research should continue on the many problems connected with its further improvement.

We think the utility of the random-search information that balloons would bring back is of minor value compared with the increasing potentialities of other pre-D-Day systems. According to the briefings given the BEACON HILL group, what is needed is not so much general area-search information as specific information on Soviet military forces and on targets whose location and general features are known. This latter sort of information can be gathered with good efficiency only by controlled search; the uncontrollability and small payload of the free balloon makes it less suitable for this task than powered systems.

Nevertheless, we believe that general area-search information obtained with low efficiency is preferable to no information at all, and we are told that balloons may be the only politically acceptable pre-D-Day vehicle. We therefore advocate further experimentation, especially to obtain data on winds and probable recovery rates and to explore light and compact camera techniques. We expect balloons may be found useful to carry repeaters for electromagnetic intercept operations at the border (see p. 168 of this chapter and Chapter 4).

The current balloon program appears to be delayed by technical difficulties which we have not been able to analyze in detail. We suggest giving much greater emphasis to

~~CONFIDENTIAL~~

~~SECRET~~

~~SECRET~~

~~CONFIDENTIAL~~

the development aspects of the program before attempting final-phase engineering for production.

It is recommended that:

- (a) Research be continued on the fundamental problems of high-altitude, long-duration balloon flights;
- (b) Data be obtained on wind and recovery rates, and experiments be made with light and compact camera equipment;
- (c) The development aspects of the balloon program be emphasized before final-phase engineering production is attempted.

Two types of vehicles capable of pre-D-Day controlled search offer promise for the immediate time period. The first is a turbojet-powered, photographic, manned aircraft (subsequently dronable), in which altitude is sought at the expense of all other performance parameters. Such an aircraft might be made operationally available in the 1952 to 1956 period as a crash modification of an existing type. (A survey to select the most satisfactory type might include modifications of the Canberra, or the RB-66.) With high-altitude performance substantially in excess of 60,000 feet, with a penetration capability of 500 miles or more, and with the elements of surprise and initiative acting completely in our favor, we would have in being an instrument of extreme value for several years, which could be used should cold war political considerations permit or should the imminence of full hostilities dictate the dispatch of such a reconnaissance force.

The second type of controlled-search vehicle is a modified guided missile. Since the guidance requirements involved in using such a vehicle for reconnaissance are less difficult to meet than those that characterize its use for bombardment, there is every reason to suppose that rather simple guidance systems would suffice. The B-62 (SNARK) is fairly well developed and satisfactory as a flying machine; a less-refined guidance system might allow the use of this missile for reconnaissance purposes at an earlier date. In planning for any contemplated use of a pre-D-Day reconnaissance vehicle, the following factors should be taken into consideration: To what extent can the likelihood of detection of such a vehicle visually or by radar be minimized? If it is detected, how readily can it be brought down by interceptors or antiaircraft artillery? How effectively can such a vehicle be programed to photograph an installation of known location (such as Peenemunde, for example) and return home with its pictures?

It is recommended that:

- (a) A survey be made to determine the manned turbojet aircraft most suitable for modification to operate above 60,000 feet, and that a limited number of such reconnaissance vehicles be subsequently procured.
- (b) The reconnaissance version of the SNARK be given priority over the bombardment version.
- (c) A small number of SNARKs be fitted with camera

~~CONFIDENTIAL~~

~~SECRET~~

~~CONFIDENTIAL~~

~~SECRET~~

installations and simple guidance equipment - perhaps only a clock-programed autopilot - to serve as un-manned photo-reconnaissance aircraft.

- (d) In the development program, major emphasis be put on reducing the optical and radar visibility of the aircraft, by special paints, the use of HARP material, or in other ways.
- (e) When these photo-reconnaissance aircraft are in hand, and some experience has been gained in their operation, realistic photo-missions be run against actual targets in the United States or in England, for the purpose of learning how effective they can be as reconnaissance aircraft, and also how readily the Air Defense Command, either USAF or RAF, can detect and intercept them.

After development and test, these vehicles could be made part of a small pre-D-Day force-in-being, should political considerations permit their use.

With regard to air border surveillance by photographic, electromagnetic or radar techniques, adequate volumetric capacity and speed in vehicles flying up to 50,000 feet is not critical and is readily obtained by modification of existing cargo or bomber types. Much deeper and very useful photographic and electromagnetic penetrations could be obtained from border vehicles flying appreciably in excess of 50,000 feet. Rocket-propelled research aircraft, such as the X-1 and X-2, are of decided interest. The X-2 airplane is to be capable of reaching an altitude of more than 200,000 feet, and has a duration of several minutes above 70,000 feet. It is thus capable of long-range day photography with modified Cassegrain-type optics from extreme altitudes near the Soviet border, and could even make limited penetrations of Soviet airspace at altitudes so high as to render interception virtually impossible. High-altitude balloons on border flights could probably serve better than short-duration rocket aircraft as electromagnetic-intercept relay stations, providing line-of-sight ranges reaching hundreds of miles inside Soviet territory. Such vehicles operated on the friendly side of the border would not raise the difficult political problems attending the violation of another nation's airspace.

It is recommended that the USAF undertake an immediate program of feasibility trials intended to develop existing rocket aircraft as reconnaissance vehicles for border flights and limited penetration. This could be linked with the NACA research program. When electromagnetic relay equipment is available, balloon flights should receive operational evaluation for this border-surveillance purpose.

~~CONFIDENTIAL~~

~~SECRET~~

~~SECRET~~

~~CONFIDENTIAL~~

2. Post D-Day, 1952-1956

Should war come soon, the greatest unfilled need in the reconnaissance field would be for a fighter-performance reconnaissance plane capable of obtaining information out to a radius of about 1000 miles.

If an opportunity for an interim capability of this sort exists, we believe that every effort should be made to exploit it.

Some of the F-84E or F-84G aircraft now attached to SAC as escort fighters could be modified for photo-reconnaissance, with range extension provided by the use of pylon tanks and by refueling.

The RF-84 or RF-101 programs will provide a later and better capability of this sort, and should be given high priority. It is recommended that these programs be carried on with the SAC reconnaissance requirements in mind; specifically, this means the attainment of an operating radius of 1000 miles, provision of a refueling capability, and the design of interchangeable nose installations for various groupings of data-collection equipment. It also appears desirable to give these aircraft the capability of operating as parasites.

For larger radii, or in cases where the bulk and weight of the reconnaissance installation cannot be carried in a fighter type, especially in more lightly defended areas, the RB-47 will provide adequate capability. The small difference between RB-47 and fighter speed makes it seem preferable to use the RB-47, rather than a fighter parasite, when radii longer than 1000 miles are wanted, except possibly when low-level reconnaissance over the target is required. In this latter case, the fighter's higher load factor, greater maneuverability, smaller size, and lower vulnerability may justify the complications of parasite or refueling operations. In those special cases where the problem is bulk and weight of payload, rather than range, the fighter cannot be used, of course.

A successful RB-62 unmanned reconnaissance aircraft will be useful after D-Day as well as before, particularly for special missions.

In discussing the needs and requirements for long-range reconnaissance, we have been impressed with arguments supporting the view that the RB-47 can meet the maximum volume and payload requirements of any properly designed reconnaissance system, and that its range is sufficient to cover the essential target areas from peripheral bases or with refueling techniques. However, we have not considered it part of our assignment to examine all aspects of the current requirements for aircraft larger than the B-47. The only important consideration we wish to advance is based on our study (in Chapter 4) of electromagnetic intercept techniques. The recommended development in intercept receivers can substantially reduce the number of operators and the weight and volume of equipment required in electromagnetic intercept operations.

3. Pre-D-Day, 1956-1960

In the future time period beyond 1956, the extent and character of Soviet air defense capabilities can only be guessed. It may or may not be possible for unmanned reconnaissance vehicles such as SNARK to operate with success over unfriendly territory prior to D-Day. However, the performance of such vehicles will also improve, and they may continue to be useful. It is possible that the NAVAHO will become operational during the time period of

~~CONFIDENTIAL~~

~~SECRET~~



~~SECRET~~

~~CONFIDENTIAL~~

interest here.

It is therefore recommended that the development program on the NAVAHO vehicle include a reconnaissance version of this aircraft.

It seems very likely that extremely high speed at extremely high altitude will continue to be effective protection over hostile territory. Such performance can, so far as we know now, be attained only by use of a rocket power plant. The present rocket program displays a curious gap. There are under development ballistic rockets of rather short range - about 150 miles. From these we jump to studies of ballistic rockets having intercontinental ranges of 5000 miles, and even satellites. Practical realization of these latter programs is clearly many years off.

There seems to be a place in the program for a rocket-propelled aircraft with characteristics between those of the X-2 airplane and those of long-range ballistic rockets. Such an aircraft would have considerable endurance above, say, 80,000 feet; this would defend it against any foreseeable air-breathing interceptors, while its power-on performance should enable it to contend with rocket interceptors at least on even terms. This aircraft might have alternate piloted and drone versions, and would be able to penetrate enemy airspace at extreme altitude or perform border observation at very-high altitude. The development and use of this aircraft would appear to present fewer difficulties than would attend the development of a ballistic rocket having the same capabilities, and the operational utility of the rocket aircraft would seem much greater.

Based on progress with the reconnaissance X-2 recommended for the 1952-1956 period, a design study should be initiated for a more advanced rocket-propelled reconnaissance aircraft.

In view of the very slow rate of progress with ballistic rocket development over the past six years, it is believed unlikely that - even with a high-priority program of development - useful reconnaissance vehicles could be achieved by 1960 in the form either of the intercontinental ballistic rocket or of the satellite. At the present time, we believe the appropriate course is to continue the existing program of components studies on such items as a small self-contained power plant; as results are achieved, their possible application to a future satellite development should be further examined.

#### 4. Post D-Day, 1956-1960

As fighter types continue to be developed, the performance of the fighter-type reconnaissance plane can be improved.

It is recommended, in this connection, that all preliminary design studies of fighters, other than short-range interceptors, be accompanied by design studies of a reconnaissance version of the airplane, as has been recently done for future bomber types.

~~CONFIDENTIAL~~

~~SECRET~~

~~SECRET~~

~~CONFIDENTIAL~~

The place of the RB-47 as a long-range reconnaissance airplane will presumably be taken by one of the supersonic medium bombers now commencing development, either the MX 1626 or the MX 1712. Reconnaissance versions are under study for both these types.

Low-altitude reconnaissance over targets with strong local defenses is a difficult and dangerous job, yet it is often of vital importance in connection with bomb-damage assessment, for example. A small, very fast, unmanned terminal missile with maximum range of about 100 miles appears to be a very promising vehicle for penetrating local defenses at low altitude to perform reconnaissance. The sensory equipment of such a missile will ordinarily be photoelectric in nature; its indications must be transmitted back to the launching airplane for recording and use.

It is recommended that an existing missile type, such as the SHRIKE, be chosen for this use, that a vigorous program of development of sensing and relaying equipment be established, and that actual trials of this technique be commenced as soon as possible. When the technique is in hand, realistic trials against heavy concentrations of antiaircraft defense should be conducted in cooperation with either the Army or the Navy.

In addition, a full reconnaissance version of this bomber should be planned during the design phase. Whether it will ultimately be produced will depend on program factors unforeseeable at this time. It will be a question of whether the low-altitude bomber is sufficiently advantageous when compared with the low-altitude capability in the RF type, in the terminal missiles, and in high-altitude RB type to justify an additional model in the SAC reconnaissance inventory. The RF type and the high-altitude RB type will continue to be necessary in this time period, for our experience indicates that many reconnaissance tasks calling for area surveillance and search will still have to be done at high altitudes.

~~CONFIDENTIAL~~

~~SECRET~~

~~SECRET~~

~~CONFIDENTIAL~~

CHAPTER 12

SPECIALIZED RECONNAISSANCE UNITS

A. INTRODUCTION

The Air Force is a huge organization in which standardization is paramount. Many items of equipment such as radios, radar sets, bombsights, cameras, navigation equipment, gun cameras and the like must be employed in terms of thousands of units. It is obvious that as many as possible of these items must be standardized, inexpensive, rugged, and suitable for mass production. Otherwise, the present strain on the nation's economy would be much increased.

By the same token, standardization and simplicity very often prevent the fullest use of the nation's technical skills on which our survival may well depend. Quality and quantity are here in conflict. Are we to discard the high peak of technical achievement in order to satisfy mass needs? Are we in danger of confining ourselves to the mediocre quality we suppose our enemy to have in many respects? We know that our enemy has numerical superiority. Are we losing out on quality as well?

Even in cases where efforts have been made to supply the Air Force with equipment of unusual proficiency, can we be sure that the equipment is properly used? In World War II, a photographic mission was often rated merely by the fact that pictures were taken, not by the quality of the pictures. We have learned, however, that training is fully as important as equipment, and that complicated equipment requires special training on the part of the users.

We can use the weapon systems approach in choosing the most suitable standard equipment for general use, which implies an over-all study of requirements, from the conception of a mission through to completion, and the selection of optimum equipment for the job. However, we can suppose that our enemy is equally intelligent and is also attempting to produce optimum equipment for his own mass use. Certainly, no one can doubt that the MIG-15 is a valuable fighter for general use and that the U.S.S.R. is sending its pilots to "school" in Korea to achieve a better plane-pilot combination.

If we are to assert a qualitative superiority over the Soviets, it is essential that we adopt the concept of Specialized Reconnaissance Units set up for extremely important, even though relatively few, missions. Here we appear to be deviating from our belief that one of the most important tasks of this Study Group is to make recommendations that will simplify the problems of the Air Force. Here we seem to be pleading for retention of complicated techniques and equipment, and for a departure from standardization.

We believe that both ends can be served at once, in a thoroughly practical way. On the one hand, we seek to relieve the Air Force from burdening reconnaissance with specialized tasks and equipment that go beyond the training and ability of its regular personnel. On the other hand, we should like to gather specialized equipment, personnel and tasks together into units where concentration will lend effectiveness. We also fully expect that, when competent men are assigned to these specialized units, they will quickly exploit the possibilities of their equipment.

~~CONFIDENTIAL~~

~~SECRET~~

~~SECRET~~

~~CONFIDENTIAL~~

We realize how complex is the organizational problem of setting up such units, and how important it is not to disturb existing Commands. The members of this Study Group are not qualified to decide such internal problems of the Air Force, and in any case the matter requires prolonged study.

Consequently, the following comments on the position of specialized units within the Air Force are to be regarded simply as a starting point for more serious study carried out by the Air Force itself.

At the present time, owing to the static nature of the cold war, it has been possible for intelligence personnel charged with strategic target work to be assigned to the Director of Intelligence in the Pentagon. Here, the intelligence information from numerous sources comes to a focus, so target work can be done with maximum effectiveness.

After D-Day, the bulk of intelligence data will come from the operations of the Strategic Air Command. Consequently, target analysis will be shifted from Headquarters USAF to SAC. The need for fast action by combat forces will have increased to such an extent that target work can no longer be accomplished efficiently at higher headquarters.

In the case of the Tactical Air Command, some target work is done at Headquarters USAF, mainly for planning purposes. But even now, target folders are prepared and kept in the theater.

During actual operations, the need for specialized reconnaissance will thus be recognized first at the combat command headquarters. It will be necessary, then, for the SAC Commander or the Theater Commander to have at his own disposal the facilities and personnel to do this kind of work. Specialized reconnaissance units must then operate from TAC or SAC bases, use their facilities, etc., to such an extent that nothing will be gained by having the units under a separate command elsewhere. The concept of the "team" is of the utmost importance. Hence, we presume that specialized reconnaissance units would be established by the Air Force as part of the team at any particular theater or command.

In World War II, a Director of Technical Services at each major headquarters had a small staff of well-qualified scientific and engineering personnel. This officer was empowered to be in direct contact with research and development agencies without being required necessarily to clear through Headquarters USAF, and only to a minimum extent through the Air Materiel Command.

The need for such a Director of Technical Services now seems greater than before. This officer would be the logical person to control the technical aspects of the reconnaissance units assigned to his command or headquarters. He would be in a position to demand quick fixes from research and development agencies. He would see that all members of the specialized units were technically qualified. It is extremely important that such an officer be empowered to maintain as direct contact as possible with laboratories in the United States, and that he be able to call specialists to his headquarters to advise on equipment and missions.

The actual operations of the specialized reconnaissance units would come under an agency to be designated by the Commander at the base or headquarters. In like manner, the assignments of the unit would be determined by the same or another Air Force agency at command level, which could establish appropriate priorities for this type of mission.

~~CONFIDENTIAL~~

~~SECRET~~

~~SECRET~~

~~CONFIDENTIAL~~

Most important of all, we can rightfully expect that in time the outstanding personnel from regular reconnaissance outfits will be assigned to accomplish the specialized work. In some cases, unusually good crews might be assigned to the units en masse. At the higher-officer level, there should be men of excellent training and ability. They might be drawn from the best technological schools and allowed to take advantage of any educational opportunities that would further their work. We can expect that they would have access to the top scientists and laboratories of the nation through their Director of Technical Services. We can expect the units to maintain scientific consultants from qualified institutions, on a quondam basis, who at times should give formal series of lectures on selected subjects.

Qualified officers among the units should be assigned to the task of setting up requirements, new procedures, new equipment, novel installations, etc. They should be aided by selected technicians who would operate the specialized equipment and maintain it. This equipment should cover the entire field of reconnaissance instruments, including radar, photography, ECM, passive infrared and passive microwave surveillance, high-altitude peripheral obliques, and the like. The personnel of the units could also aid in special missions arising outside their particular headquarters. Thus, for example, if Headquarters USAF decided to try out a new type of vertical rocket for high-altitude peripheral oblique photography and sent engineers from the parent manufacturer out to a base to set up the rocket, the personnel of the specialized unit should cooperate fully.

We anticipate that the new specialized units should have any and all equipment deemed necessary for their missions within reasonable budgetary limitations. There will be many times when standard equipment can be used to accomplish a special mission of critical importance. Similarly, some missions at the other end of the scale might require the procurement of a very specialized piece of equipment.

Safeguards must be instituted (perhaps by appropriate authority in the United States) to ensure that these specialized units are not stranded at the ends of long lines of communication. Similarly, means must be provided for communication among units, for often the units can accomplish little if they are not fully aware of activities of similar units elsewhere. The whole structure should be integrated through a central agency which can route questions and answers, information, new equipment, and even personnel to the various units. Close and continuous cooperation will be necessary between this central agency and Headquarters USAF.

## B. EXAMPLES OF SPECIALIZED EQUIPMENT AND MISSIONS

### 1. Photography

In Chapter 5, we recommend that the regular Air Force reconnaissance units should not use lenses of focal length greater than 36 inches. This is not to say that larger equipment should be prohibited altogether. Certainly, the regular units may have to undertake special assignments from time to time, and may need to use large cameras. Our only purpose here is to prevent unnecessary quantity production of this large, expensive equipment, and to prevent misuse and poor yields by relatively untrained personnel.

We visualize that the new units envisioned for photography would have at their disposal a limited number of cameras of all sizes and types, large and small. The unit should

~~CONFIDENTIAL~~

~~SECRET~~

~~CONFIDENTIAL SECRET~~

have adequate space for requisite laboratory testing, and for auxiliary equipment of all kinds that may be needed.

Typical equipment for such specialized units might include the following.

40-inch  $f/5.0$  telephoto for  $9 \times 9$  format with automatic focusing and thermostating (can be used in fighters).

48-inch  $f/6.3$  telephoto for  $9 \times 18$  format.

48-inch  $f/4.5$  straight lens for  $18 \times 18$  format (intended for night photography in infrared light).

48-inch  $f/8$  straight lens for  $9 \times 9$  format (apochromatic and intended for use with color film).

60-inch  $f/6.0$  telephoto, folded, for  $9 \times 9$  (can be used in fighters).

60-inch  $f/5.0$  telephoto for  $9 \times 18$  format.

72-inch  $f/5.6$  straight lens for  $18 \times 18$  format.

96-inch  $f/8.0$  straight lens for  $18 \times 36$ .

100-inch  $f/10$  straight lens for  $9 \times 18$  format, folded.

144-inch  $f/8.0$  straight lens for  $18 \times 36$  format, folded.

240-inch  $f/8.0$  straight lens for  $18 \times 36$  format, folded.

36-inch apochromatic lens for  $9 \times 9$  format (color film).

120-degree wide-angle spherical shell camera with 5.95-inch focal length with rectifier.

Spotting cameras of various sizes and focal lengths.

Panoramic cameras of various sizes and focal lengths.

Strip cameras.

Special mapping cameras and mapping aids.

Special cameras require special installations. The special units should not be without image-motion compensation except in the few cases where technical considerations indicate the need is negligible. They should use antivibration mounts, center-of-gravity mounts, gyroscopically stabilized mounts, or whatever else is deemed necessary; at all stages, they should know their equipment exhaustively.

If the units are to achieve maximum effectiveness, they should be able to influence the development of all kinds of reconnaissance vehicles and their equipment. In some cases, a single model equipped experimentally can bring back essential information without waiting for moderate or mass production. For example, we are told the existing X-1 has been on about 100 flights. It ought to be possible by now to make use of this airplane for reconnaissance for high-altitude peripheral obliques, even if it were equipped only with a 6-inch camera. With a spotting camera of 48-inch focal length, the X-1 would enable its pilot to obtain photographs far into eastern Germany without entering Soviet-controlled territory. The X-2 might permit us to obtain peripheral obliques next year from altitudes of 45 miles (see Chapter 6). If we are to delay until such vehicles become operational, we may have to wait for five years

~~CONFIDENTIAL~~

~~SECRET~~

or more. Meanwhile, one aircraft properly handled could accomplish a great deal. This could properly be a function of the specialized reconnaissance units.

2. Other Reconnaissance Missions

We have discussed the manner in which specialized units might handle specialized tasks in photographic reconnaissance. Similar assignments might be made for unique missions or equipment in other fields of reconnaissance - radar, electromagnetic intercept, photoelectric, infrared, etc. Specific references to such specialized tasks are indicated in the various chapters dealing with these subjects.

It should be kept strictly in mind that the primary mission of the specialized reconnaissance units is reconnaissance and not research and development. The latter is not to be ruled out, but the burden of research and development can more properly be carried by agencies established for those functions.

The size of the individual specialized unit should be adjusted for maximum return. There will be a natural growth in size as the units undertake more and more types of missions. Quality of output is the important consideration, and we believe that this quality will be related directly to the training and ability of the personnel selected.

In this discussion, we repeat that, by setting up these specialized units, the Air Force can simplify the problems of the regular reconnaissance wings. Even if the new units fall short of the ideal, much will have been accomplished merely if the regular wings do not have to be concerned with special devices and installations.

Specialized reconnaissance units should be set up within the Air Force in order to make the most effective use of specialized equipment of all kinds - photographic, infrared, radar, microwave, ECM, ferret, and the like. The units will return a yield markedly above what can be accomplished by the regular reconnaissance wings, in both quality and type of information. We can save the energies of the regular reconnaissance wings for standard operations, without burdening them with time-consuming special devices and missions. We can thereby achieve a wiser division of labor and a more efficient utilization of the nation's technical skills.

~~SECRET~~

~~CONFIDENTIAL~~

CHAPTER 13  
HANDLING AND EVALUATION OF INTELLIGENCE

A. HANDLING RECONNAISSANCE DATA

The problems in handling reconnaissance data are too well understood by the Air Force to require restatement here. To the common problems of bulk, incomplete locational information, insufficient coverage, and delays in processing and interpretation, there is for all types of reconnaissance material an additional problem of recognizing unequivocally what is on the material collected.

Two other difficulties override the handling of reconnaissance materials. One is the need for channels for transmission of intelligence on a basis that will suffice for the contemplated post-D-Day load, so that the shock of the reorganization experience in Korea does not prevail. This problem can be considered only with reference to the equally urgent needs of many other agencies with comparable demands on communications channels. We have no concrete proposal to make on this point except to suggest that certain compression techniques presently being investigated should be regarded as a means for attacking this problem. Equally helpful too would be any and all efforts to reduce the volume of material from the data reduction centers to a multitude of users.

The second difficulty indicates a clearly defined need for recognizing data reduction centers as entities separate from collecting agencies and users. We recognize that something of this nature is present practice in the case of SAC's reconnaissance technical squadrons and we commend the extension of this policy. Collation and evaluation functions should be added to such reduction centers wherever practical. It is our belief that the volume problem can then be greatly improved by curtailing the flow of raw data from data reduction centers, carrying out instead the major portion of the interpretation function and much of the collation and evaluation functions at these points, and severely restricting the forwarding of original material. We believe that most interpreted data should be sent as intelligence information, by teletype, radio and published reports.

Our only conclusion with regard to the handling of reconnaissance data relates to an improvement in correlating navigational and indexing data with observations in flight. No reconnaissance information is of value unless and until it can be identified accurately by time and location. For short-range tactical missions where SHORAN is used for combat aircraft navigation, it would be a simple matter to record the SHORAN coordinates on the various film records (as is already being done by commercial oil companies in their aerial magnetic explorations). Very little developmental work would be needed to adapt the recording of SHORAN data for labeling of reconnaissance material. For longer-range missions, future developments such as LORAN and WHYN can be adapted in much the same way as SHORAN. Other developments under way in the Air Force present continuously to the navigator or pilot certain data such as latitude and longitude of the vehicle. We believe that a study directed toward a light-weight simple, reliable equipment for a continuously recording navigational log would lead to a device that could be used for continuously imprinting locational and indexing data on reconnaissance material. There is no obstacle to the immediate design of labeling devices for recording

~~CONFIDENTIAL~~

~~SECRET~~



~~CONFIDENTIAL~~

~~SECRET~~

navigational and operational data on all reconnaissance information - visual and radar photographs, and radar map and EM intercept records. The instruments call only for engineering development. Considerable time and manpower now devoted to identification would be conserved, the location would be certain on all collected information, and the timeliness for reconnaissance information would be improved significantly.

The data reduction problems concerning photographic and radar data are discussed elsewhere in this Report (see specifically Chapters 5, 6, 7, and 9). One aspect of photo-interpretation is discussed in Chapter 14.

We recommend that data reduction centers be established as separate entities, that every effort be made to design devices for in-flight recording of locational and operational data, that the flow of raw intelligence from data reduction centers be curtailed, and that the forwarding of original material be restricted.

#### B. THE PROBLEM OF HANDLING INTELLIGENCE

One of the most difficult problems always encountered by a modern air force is the same old and classical problem of military intelligence - the fitting together of fragmentary information into an accurate appreciation of a military situation. Although the collection of information gets speeded up by modern technical contrivances, the reduction of fragmentary information to intelligence is not susceptible to improvement by hardware alone. Thought and ingenuity are essential ingredients. Nevertheless, certain aspects of the data-handling problem might be better solved with the aid of mechanical devices.

By fragmentary information we mean Air Attache reports, prisoner interrogations, photo-interpretations and the like, all of which have to be sorted, collated, evaluated and reduced to a finished intelligence report on a certain specific topic, such as, "What is the distribution of Soviet airfields in Eastern Europe?" We further consider these reports themselves as fragmentary, because they too have to be sorted, collated and reduced to intelligence on larger subjects, such as "What are Soviet intentions in Europe in 1952?"

The asking and answering of such questions are activities in the Directorate of Intelligence, and are described in the "Missions and Functions" of each unit. The subjects about which the units require information are described in a voluminous loose-leaf manuscript which serves as a guide for the Documents and Dissemination (D & D) Branch. These requirements are not static, but change from time to time. The mere remembering of all the requirements set forth is almost beyond the capabilities of any human being.

Four persons now cope with disseminating all incoming documents and two others deal with WRINGER Reports. Distribution is made on a "customer request" basis in accordance with the "readers' bible" (D & D Branch Screening Requirements for Reading Panel). These customers are listed in the chart in Fig. 13-1 to show the extent of the distribution list.

The number of pages that must be reproduced and distributed by D & D has grown enormously in the last few years. At the present time, the incoming flow of documents averages about 1000 per day. In 1951, 200,000 documents were received and 1,300,000 documents were dispatched - a total of 3,500,000 pages. The volume for 1952 can be expected to increase.

~~CONFIDENTIAL~~

~~SECRET~~

~~SECRET~~

~~CONFIDENTIAL~~

Fig. 13-1

DISTRIBUTION SHEET				Date	AF No.
DIRECTORATE OF INTELLIGENCE				INTERIOR COMMANDS	
AFOIN				ACIS	
AFOIN - ATIC				AFSS	
AFOIN - A				AIR U	
AFOIN - E				APG	
AI DIGEST				MATS	
AFOIN - T				SAC	
T/TP				SCH AV MED	
T/TR				SWC	
T/AO				TAC	
T/AV				TRC	
T/PV				ARDC	
AFOIN - V				ADC	
V/AE				EADF	
V/AF				CADF	
V/TC				WADF	
AFOIN - C				CONAC	
C/CC				LOWRY	
C/RC					
C/SR				1ST AF	
C/EE				4TH AF	
C/DD				8TH AF	
HEADQUARTERS USAF				10TH AF	
OSAF				14TH AF	
AFCSI					
AFCSG				NON-USAF AGENCIES	
AFDRD				ARMY	
AFOAC				NAVY	
AFOAT - I				STATE	
AFOOP				CIA	
AFOPD				AFSA	
AFOPW				OSD - CDL	
AFCAG				JCS	
OVERSEAS AIR FORCES				RDB	
AL AIR CMD				AED	
AL CMD				MBPC	
CAIRC				NSRB	
NEAC					
FEAF					
USAFE				FOREIGN SERVICES	
3RD AF				RAF	
5TH AF				RCAF	
20TH AF				AJSS	
5TH AIR DIV				BJSM	
AFOSI				MISCELLANEOUS	
Remarks					
Classification	DO	RO	R	NR	
S C R U					

AFHQ Form 0-234

~~CONFIDENTIAL~~

~~SECRET~~

In many cases the same report may go to 10 or more using agencies. This may be ascribed to two causes:

- (1) Since it is virtually impossible to memorize the thick volume with its vast catalogue of requests, the reading panel may send out more documents than necessary in order to be on the safe side;
- (2) Because there is an overlapping among the intelligence requirements of the agencies, there is a duplication of requests for documents containing raw intelligence.

We are not in a position to discuss the problems of overlapping intelligence requirements and the resultant bulk in the dissemination of raw information. We do, however, propose to treat in some detail the following segments of the data-handling problem:

- (1) Facilitating the timely flow of pertinent information and reducing the flow of nonessential data.
- (2) Simplifying the process of transforming raw information into finished intelligence.
- (3) Reducing the number of sheets that must now be reproduced and distributed daily per item of intelligence.

#### C. MECHANIZED INFORMATION HANDLING

##### 1. What to Mechanize

There are two ways of getting intelligence. The first (and probably the best) is to decide what it is we want to know, set up a team of experts, and send them out to get it. A typical example is the Alsos Mission. There are, however, many questions that do not warrant such a specific effort, and here we might as well rely on the collection and collation of individual items. Many of the items are of very little intrinsic or ultimate value, but these, nevertheless, should be recorded somewhere within the Air Force. It is this type of information that we have in mind in this section. Because of its large volume, it is highly desirable to use mechanical means so far as possible in its dissemination and collation. If this is done efficiently, there is no doubt that on occasion a real nugget of intelligence will be revealed by a fragment in its proper context.

##### 2. Program for the Air Force

The data-handling problem of the Directorate of Intelligence differs only in detail from the so-called "library problem" which plagues the arts and sciences, and modern civilization in general; but in the Air Force the situation is becoming peculiarly acute. The existence of this over-all "library" problem is widely recognized, numerous methods have been proposed for solving it, and a few mechanical aids have been assembled. None of these alone is suitable for the Air Force, but we believe that a combination of several might turn out to be very useful. The basic ideas we might combine are those represented by the following procedures:

- (1) Recording on microfilm;
- (2) Identification by "underlining" words, as in a newspaper morgue;
- (3) Converting the letters of the words to a representation (in dots and blanks) by the same techniques used in Braille printing;

- (4) Storage of the key words in the form of minute dots on the photographic film;
- (5) Retrieval from storage by the techniques used in modern computing machines;
- (6) Duplication of the original by V-mail methods.

3. An Integrated System

The incorporation of all these procedures into one integrated system is admittedly a bold step, but the advantages could be tremendous. We shall try to illustrate how such an over-all system might work.

D. USE OF MICROFILM

1. Advantages

For Air Force requirements, broadly speaking, the duplication, sorting and handling of documents (including charts and photographs where loss of very fine resolution is not important) can be mechanized by photographing on microfilm all incoming documents, in order of accession. Microfilm is a compact practical form of storage. It is more expensive (7¢ a sheet) than the present methods such as ozalid (4¢ a sheet), but this cost will be saved by the complete mechanization of the subsequent handling of the material. As a further advantage, all incoming material can be microfilmed, regardless of whether or not it has been prepared by U.S. personnel; this eliminates previous sorting on this basis.

With the information on microfilm, the actual sorting (determined by means described in the next section) can be done very efficiently by a technique actually put into practice in the well-known Rapid Selector. In this machine, on signal, a frame on the original reel is photographed onto a new reel by the triggering of an Edgerton flash lamp. Very high speeds of 5000 pages per minute have been achieved.

If one is willing to read microfilm, duplication is also accomplished in this step. However, we strongly recommend that the user (evaluator or analyst) be not asked to study microfilm, but that he be presented duplicates of the original material in the form of "blow ups" from the second microfilm reel - by the equipment used so successfully during the war for duplicating V-mail. As we shall see later, the pages of V-mail will constitute a booklet on a topic requested by the evaluator, containing all pertinent material on the original reel, in a throw-away form.

2. Labeling of Microfilmed Information

The duplication of selected frames from the microfilm onto another reel, described above, implies a selection process (singling out pertinent frames) and a collation process (collecting on the several microfilms all material on the same topic). This can be done mechanically by a procedure similar to that used in the Rapid Selector. Let us assume that associated with each frame there is a number of key descriptive words. How these are chosen is the subject of the next section. For the moment, we might visualize the procedure used in newspaper morgues of underlining certain key words, or of writing them in the margin. It is necessary to store these words, along with the photograph of the whole page, on the film in such a way that they can be recognized mechanically (e. g., by photocells). The straightforward way to do this is to convert the letters in the words to a suitable form, such as a series of dots and blanks

~~CONFIDENTIAL~~

~~SECRET~~

(technically known as a "binary notation"). For example, the letters could be:

A 0 - 0 0 0 0 -  
B 0 - 0 0 0 - 0  
C 0 - 0 0 0 - -  
Z 0 - - - 0 - 0

Lower case could be:

a - - 0 0 0 0 -  
etc.

Digits could be in the well-known binary form:

1 0 0 0 0 0 0 -  
2 0 0 0 0 0 - 0  
3 0 0 0 0 0 - -  
9 0 0 0 - 0 0 -

The complete set of conventional symbols - digits, and the upper- and lower-case alphabet - requires seven locations for identification - technically known as a "bit". This is the most efficient method of storage of information. To distinguish ordinary printed letters, we need discrimination in about 9 levels vertically and 7 horizontally - or 63 altogether - in order for the letter to be relatively clear and not too fuzzy. (Good printed matter, however, is much better resolved than this, using up space for a thousand "bits".) Thus the storage of letters as binary dots requires less space than the printed word. With the best emulsion now available, it would be possible to store the contents of all the books in the Library of Congress in a cubic yard of film. The average word has five letters, and requires 35 locations. Thus, there is ample space to store several hundred words in a frame alongside the photograph.

Key words (descriptors) are typed on a special typewriter, such as is used in preparing documents in Braille, which converts the letters to binary notation, which in turn would be stored photographically as black and white spots on the microfilm alongside the photograph of the written material.

### 3. The Rapid Selector

The Rapid Selector is a piece of equipment designed by Dr. S. Vannevar Bush and Ralph Shaw, and built by Engineering Research Associates. The machine has been successful, and a good deal of engineering data has been accumulated. It costs \$75,000, reads 5000 frames a minute and can accommodate 6 identification codes. A number of improvements is indicated, and the National Bureau of Standards is one of several agencies engaged in these tasks.

The Rapid Selector has not had a revolutionary effect on bibliographic techniques and is not recommended to the Air Force in its present state. The main difficulty seems to be the bottleneck of introducing the identification code. The delay has nothing to do with the technical features of the machine. It can be entirely attributed to the archaic methods of indexing current in bibliography.

## E IDENTIFICATION OF MICROFILMED INFORMATION

### 1. Difficulties of Indexing

The storage of information on microfilm, and its duplication as V-mail is a satisfactory technical solution to some phases of the library problem; but so far we have

~~CONFIDENTIAL~~

~~SECRET~~

~~SECRET~~

~~CONFIDENTIAL~~

completely ignored the central difficulty of identification by content so that selected topics may be retrieved.

This task in the past has been assumed by librarians, and they seem to have had little success in solving the problem. It is generally conceded that classification schemes (such as the Classification Decimale, or that of the Library of Congress, or any other library) are of questionable value to the user. In the first place, they require universal knowledge on the part of the classifier. In the Air Force scheme, this would require the most knowledgeable personnel at the input where the volume is overwhelming.

It is by no means obvious that documentary material needs to be filed, stored or arranged in a systematic way or in a well-defined sequence. It is impossible to place documents on all related subjects close together physically, because they exhibit a multidimensional relationship to one another.

A user of information requires a cross-cut of documents that is unpredictable and variable. The librarian's code makes the information even further remote from the user, who has to decode the classification scheme into his immediate wants. Basically, the difficulty lies in the assumption on the librarian's part that knowledge can be organized by a universal classification scheme as plants and animals are arranged in the conventional biological families, genera, species, etc. In recent years, it has been recognized that the users of libraries do not look at information that way.\*

An ultimate ideal would be to have every printed word read by a reading machine and mechanically converted to a form that could be stored in some manner, so that any word could be rapidly located and extracted with its context. There is one objection to this: the conventional key word describing an idea may not, in fact, appear in the text. This difficulty could be to a large extent resolved by search, not on one word, but on whole groups of words.

## 2. Key Words

A practicable procedure is to put key words, which actually occur in the document or which describe the material, into an automatic memory. As described above, we visualize a device similar to the Rapid Selector in which each document is numbered and recorded on microfilm. Associated with each frame, is one (or several) other frames which bear the key words stored as a pattern of dots, susceptible to recognition by photocells. As many key words are recorded as is economically possible. We have in mind about 25. This is essentially the method used by newspaper "morgues" where cuttings are filed away with key words underlined in red.

The latter system of underlining is excellent for manual retrieval, because the eye and the mind of the searcher are very active in picking out the right kind of word and making mental associations. On the other hand, for a mechanical method of retrieval, it would probably turn out to be too broad in its coverage of words.

To summarize the discussion of indexing, we have on the one hand the classical

---

\*A better example which is unlikely to turn out to be entirely satisfactory and yet will be fruitful, is a mathematical one (specifically, Boolean algebra). This has at least one great advantage, namely that the sorting and dissemination of information can be adapted to devices similar to modern large-scale automatic computing machines.

~~CONFIDENTIAL~~

~~SECRET~~

~~CONFIDENTIAL~~ ~~SECRET~~

approach of fitting ideas into a preconceived fixed "biological" scheme. This requires thinking by the indexer, and for this reason alone becomes a bottleneck. It also implies that the user thinks in terms of the same scheme, which is rarely true. On the other hand, we have the "morgue" scheme of merely underlining key words. This requires little thinking by the indexer, and in fact could be done mechanically by a reading machine if enough technical effort were devoted to such a project. The objection to this method, when retrieval is attempted by mechanical means, is that the searcher has to do a lot of thinking in order to write down all possible grammatical forms in which the idea he is searching for might appear.

### 3. Coordinate Indexing

We suggest a compromise indexing scheme, of "coordinate indexing," which would seem to be adaptable to machine methods and to require a minimum of thinking on the part of the indexer or retriever. It does not require a code book. We believe it avoids the major obstacle in the use of the Rapid-Selector type of machine, by accelerating the indexing of the frames. This method was developed by the Information Division of AEC and has been used by them, and by the Naval Section of the Library of Congress. A factor of 5 has been achieved over present methods of classifying documents, and rates up to 2000 documents per person per day have been reached.

The principal feature of coordinate indexing is that it recognizes that it is impracticable to allow "underlining" of any kind of word, and that some discipline must be imposed by insisting that the key descriptive words must belong only to certain definite categories. The choice of categories is determined by the particular body of information that is to be indexed. For example, if we had the problem of getting a general picture of the scientific activities in the Soviet Union from reading Russian newspapers, we could look for words in two categories. One would be proper names (especially of men with scientific reputations) and the other would be sites, including institutes, universities, military bases, etc. This is because the information we want is basically the knowledge that a certain man with known interests and capabilities is at (or has left) a certain laboratory. The interconnection of these fragments would build up a very revealing picture of Soviet scientific intentions. By picking out newspaper items containing one or more words belonging to one category simultaneously with one or more words belonging to the second category, we could quickly collect the pertinent material.

The principle of labeling material with words belonging to predetermined categories appropriate to the kind of intelligence required is more flexible and easier to apply than a rigid bibliographic index. It is much simpler than underlining, from the point of view of the searcher who now knows he must restrict his inquiries to these particular categories. Otherwise, within each category the actual words are unlimited - new ones may be added and old ones dropped as interests change. In the original method as developed by M. Taube, the words were limited to a given generic level of broadness. For example, we might have the category "aircraft" in which one includes, "MIG-15," "TU-4," but not the more generic term "vehicles." With the proposed mechanization of the procedure, it now seems that this restriction can be removed.

### 4. The Basic Word List

The categories of the word list should be set up in accordance with the

~~CONFIDENTIAL~~

~~SECRET~~

priorities established by the users, but should be equally adapted to the capabilities of the collectors and the working procedures of the reducers. How do we choose the categories? To answer this, we must answer the question: What information does Intelligence want? It does not want to know everything about everything, as one might surmise from reading the official requests from D&D. In large part, intelligence is knowledge about Things at Places, such as "MIGs at Key West," and Activities, such as "Tanks Produced at Omsk."

To some extent, the nature of the categories depends on the capacity of the machine that must handle the stored information. If the scheme we are proposing starts off with manual methods, the categories must remain about on the level indicated. With the introduction of mechanical devices, more categories or more detailed categories can be introduced. (For instance, places might be restricted to towns or districts at first; later factory names could be used). In any case, the system is flexible and can grow. There need no longer be confusion over problems of indexing, such as:

Tanks, production of, at Omsk; or  
Omsk, tanks, production of, etc.

The list of categories is not an index. For mechanical sorting, the words do not even have to be arranged in alphabetical order. Synonyms can be used. Both generic and simple words can be used, i.e., "weapons," or "tanks," "self-propelled guns," etc. Abbreviations, which are often a problem, are being investigated by Project TACIT. Double words (Key West) and names (Stalin, J. and Stalin, Joseph) also offer minor problems.

#### 5. Will It Work?

First, let us see whether the collector's activities can be defined in terms of Things, Places, and Activities. Clearly, the major interest, Military Data, can be listed for the most part as Things. For example, in the general category of Basic Weapons (combat vehicles, munitions, weapons, fire control, etc.) the words would be "aircraft," "TU-4," "ammunition," "machine guns," "telemetering equipment," etc. For Basic Force (combat units, transportation units, support units), we would have "troops," "generals," "troop carriers," "repair depots," etc. In the category of Personnel, names with rank can be considered as Things.

In connection with Military Installations, there are concepts such as "concentrations," (in the sense of an observed fact rather than a deduction from the assembly of fragments concerning several Things at the same Place). Until the system has been studied in detail, "concentrate" can be included under Activity. Another difficult concept is "communications" which tentatively might be a Thing, with words such as "road network," "telephone network."

Geophysical, terrain, weather, and hydrographic data are mostly handled by special projects, and incidental information falls into the scheme fairly well.

The next question is: Can the users of intelligence define what they want in these terms? By and large, they probably can. Actually, however, they are not primarily concerned with the scheme in its detail, since they are isolated from the collectors and sorters by analysts or evaluators. These are the ones who have to ask the sorter in language used by the collector for information in which they are interested. For example, the analyst responsible for Soviet developments of long-range missiles would include in his list "titanium at the Lenin



~~CONFIDENTIAL~~

~~SECRET~~

Institute," for he knows that titanium is a key material, and that this Institute has the responsibility of research in the field of rocket motors.

6. Immediate and Progressive Installation

Such a scheme as this does not have to be introduced all at once. It could easily be started, and later smoothly elaborated, by associating with each document a selection of words covering the major categories of intelligence. Sixty per cent of the documents prepared by Air Force personnel could be so described (or classified in the general sense) by the author. The remaining forty per cent would have to be read by a panel which would mark the principal words occurring (provided they lie in the approved list) or describe the thought in terms of the approved words. This would require reading which is slow, and which calls for an intelligent panel, but speeds higher than any other known method can be guaranteed. It has the advantage that the volume of stored material is reduced.

Note that we are not proposing a code book. The categories are prescribed, but the words in each category are determined by use, so that nothing is coded or forced into the scheme. The basic categories with lists of word examples can be sent to collectors, data reducers and users. These actual and virtual words become, indeed, the only means of communication between these three elements in the chain of intelligence. More specifically, the language now used, which is vague, redundant, full of double meanings and semantic difficulties, can be replaced by a list of words belonging to agreed-upon categories. The situation is not quite like Basic English - for only a few categories are permitted - but words can be added or removed at will (but with caution) by collectors, reducers or users as the scene changes.

An attractive feature of this scheme is that it can be introduced now without waiting for mechanized devices. The scheme can be adapted and expanded for machine handling without any confusion. Furthermore, the scheme could be tried out in a limited field, such as Air Order of Battle, or Targets.

7. Rate of Search

Careful attention will have to be paid to the ability of the machine to answer a sufficient number of questions per day. As a base line, let us see what could be done with equipment now in existence. The present year's take of fragmentary information is roughly a quarter of a million pages. This could be photographed on three rolls of microfilm. The Rapid Selector can examine a roll in 15 minutes. Thus we have a basic rate of 45 minutes a question or ten thousand questions a year. By "question" in this context we mean a large number of logical connectives, consisting of most of the key ideas of a single analyst, as will be discussed in the next section. If we could assume perfect mutually exclusive questioning, this would be about the right rate. Averaging 25 pages per question, it works out to 100 pages presented to an analyst per hour of working day, which is a reasonable rate of reading. At the present time, the number of different questions asked is probably much less than this. However, some questions (such as those connected with Air Order of Battle) need to be asked many times, - say, once a week. We may conclude that one machine could disseminate the present flow of information.

It is to be hoped that the collection of information will increase substantially, by a factor of, say, 10. If the machine is successful, and if users become properly acquainted with its possibilities, there might be a demand for the inclusion of other types of written material.

~~CONFIDENTIAL~~

~~SECRET~~

~~SECRET~~

~~CONFIDENTIAL~~

such as foreign newspapers, magazines and scientific journals. Thus there is unquestionably a requirement for a considerable increase in speed over the rate based on present performance.

The limit of speed in the Rapid Selector is image motion during the duplication into a new film. Although an increase in speed in the present equipment would smudge the letters on the final prints the problem is not insoluble. (The National Bureau of Standards is developing one means.) A speed increase of 10 can be expected.

There is still another way of increasing the speed, namely, by making coarse sorts of the raw data, for example, into "U.S.S.R. and Others," "Technical and Non-Technical," in a fashion similar to the present assignment of priorities 1, 2, 3, or 4 by D&D. This rough sort could be done before microfilming, or it could be done by making new reels after the first photography. The rough sorting of raw data must, however, be conducted with great care, otherwise it could destroy one of the principal features of the machine method - the guarantee that a question will be answered by data of all kinds from all sources.

A simple feedback system could be set up so that the analysts could report on each document they receive, noting whether it should be kept for future reference, or whether its timeliness has passed and the document should be put in a dead file. A simple report on frame number (to be retained or not) to be filed in a specific category, could be made by the analyst. All such reports would be used once a year in a run-off of the main film, in order to make a new one in which material of obviously passing interest is removed.

Similarly, a report could be rendered assigning some documents to specific categories when it is obvious that they would have no possible bearing on other fields. Again, such documents could be removed from the main film and copied on a new one.

No doubt other ideas will turn up for re-editing the main film at the end of a year, so that the amount of outdated material to be searched can be reduced considerably in volume.

To summarize, we can expect one machine to handle Air Force requirements until the volume of material collected is considerably larger than at present; at such time, the increased volume can be handled by improved components, experience in the necessary flow of information, or at worst by the construction of several machines.

#### 8. Structure of the Question

Besides offering a framework by which the collector abstracts and describes his information, the basic word list is a device for matching the analyst to the store of information, by guiding him in the way he asks questions of the disseminating machines.

By "question" we mean essentially the definition of the mission of an analyst or possibly of a whole division, in terms of the rudimentary language. As an example, an analyst in charge of important people has many simple questions, such as those about Marshall Stalin; any information about him is useful. A more specific question might concern "Fighters at Murmansk." This would include several similar questions such as "MIG-15s at Murmansk," or "Jets at Murmansk," with similar questions about other Places. One could give examples of negative requirements, such as TU-4s not at forward bases. The point of this is that all such elementary questions, which are essentially logical connectivities, can be asked of the machine simultaneously. The reason for this could be expanded at length, but briefly it is because the

~~CONFIDENTIAL~~

~~SECRET~~

~~CONFIDENTIAL~~ ~~SECRET~~

logical combination "at", "not at", "and", "or" can be represented by very elementary switching circuits so characteristic of modern computing machines. Thus the demands of a single analyst could be stated by a large number of such elementary questions, most of which could be searched for simultaneously.

#### F. DATA REDUCERS OR EVALUATORS

At the present time, there seems to be a great confusion concerning who gets various kinds of information. The setting-up of a set of categories might lead to a clarification of the role of Directorate of Intelligence and other Air Force agencies. It might reveal a considerable amount of duplication that could be eliminated.

A tentative list of subjects to be treated by data reducers or analysts can be set up on the basis of Things about which they ask. Ideally, each major subject should be the responsibility of one man, the best available. "Raw" information should be sent to his personal screener. The analyst then digests selected material and produces reports to be sent to appropriate users. On the basis of the approach of Chapter 3, specialists might be assigned to the following topics.

1. Air Order of Battle
2. Basic Air Combat Vehicles
3. Air Combat Vehicle Equipments
4. Soviet Defense Systems
5. Soviet Offensive Systems
6. Strategic Targets
7. Industrial Potential
8. Military Potential
9. Control and Communications Equipment
10. Fundamental Science
11. Geodesy
12. Cartography

As suggested by ATIC, it would be desirable to expand the ranks of analysts by having scientific and other types of personnel available, possibly on a spot-contract basis. For example, periodically ATIC puts out a report on Soviet developments in infrared detection. The raw data could be evaluated by an expert in this field, who would soon educate himself to prepare a list of key words describing data needed for his evaluation. It would presumably be much easier to place such contracts if the "leg work" were eliminated by supplying the contractor with the information in readable form as outlined above.

These analysts must be made to give a list of the things they want to know in order to supply users of intelligence with what they ought to know. Once the system gets established, certain words would become standard and be automatically searched for.

The basic word list, as a rudimentary language describing essential elements of intelligence, can form an intellectual framework for an over-all picture of intelligence, combining and defining the needs and duties of collectors, analysts and users.

#### G. DOCUMENTS AND DISSEMINATION LIBRARY

If the procedure outlined above were instituted, there would be little need for

~~CONFIDENTIAL~~

~~SECRET~~

~~SECRET~~

~~CONFIDENTIAL~~

a library for research work. The D&D branch may, of course, wish to retain the more valuable documents for examination of detail (e.g., color photography) lost in microfilming. But requests for information should be directed to the microfilm storage; and the answer, by rapid selection and quick duplication onto paper, should be given to the requester, with no demand for its return.

The material retained by D&D can be filed in its library by the category list rather than by a universal cataloguing system. Most of this library material is of a nature such that it would be very economical to reproduce it onto microcards. These cards would be made from the original microfilm. They can carry reduced photographs of 60 pages, which as it happens is ample for most of the items we have seen on the shelves of the D&D library. The Air Force could well afford to develop a first-class microcard reader, with a view toward the needs of Air Force analysts, rather than toward the competitive price structure of general application. The saving in space obtained by the use of microcards (a factor of 100 over documents) would be valuable, particularly in the Pentagon. Library personnel, now used in cross-indexing, could be diverted to more useful activities by the introduction of categories instead of cataloguing.

Such a systematic approach in D&D would permit cheap and quick duplication (on microcards) of pertinent material to be sent to libraries of the Intelligence Division of the various commands and reduction centers of lower echelons.

We should also point out that by having the primary information on microfilm, accessible to the analyst, who receives a throw-away V-mail compilation satisfying his own requests, we can solve the present problem caused by analysts who secrete original material in private libraries in their desk drawers. The point is that the fundamental storage of information is on microfilm, so that when a new quest on arises all previous history is searched mechanically. The library as such is merely an adjunct. We should also point out that microfilms can be easily reproduced, in whole or in part, so that each Command could have its own reels of information and its own searching machine.

#### H. INTELLIGENCE REPORTS

Finished reports could be handled in the same basic manner. It might not be necessary at first to microfilm reports, but each report should be "abstracted," not in the conventional, wordy sense, but by a list of key words belonging to suitable categories, such as the three mentioned above. Retrieval and dissemination could be carried out by the same techniques as those applied to fragmentary information. It is possible that only parts of reports would need to be selected (mechanically), thereby reducing the volume presented to the evaluator.

#### I. MISCELLANEOUS REMARKS

The problem of disseminating and collating information for Air Force Intelligence is not altogether new, for, as has been remarked, it is very similar to the difficulties of distributing and collecting scientific and other written material. The proposed solution has not been made ad hoc for the Directorate of Intelligence, but is the result of serious work in related fields during the past few years. Essentially, what we recommend is the combination of two ideas, neither of which alone has yet solved the library problem, namely:

~~CONFIDENTIAL~~

~~SECRET~~

~~CONFIDENTIAL~~ ~~SECRET~~

- (1) The high-speed mechanical facilities of duplication, sorting and collation offered by the Rapid-Selector type of machine.
- (2) The revolutionary concept of "Coordinate Indexing" which attempts to classify knowledge by a logical combination of ideas belonging to definite categories suitable to the field, which requires a minimum of thinking by the indexer or the retriever.

In the presentation of this proposal we have been aware of other possibilities, such as the one involving punched card machines (in particular the new IBM selector based on Dyson's ideas in chemistry), Sorting Rapid Selectors developed by CIA, and other developments by Engineering Research Associates. We have also considered indexing schemes of J. W. Perry and of Zatacoding.

We cannot guarantee our proposal, for no method of handling information has yet worked perfectly. But something must be done, and the combination of mechanical handling and coordinate indexing offers promising possibilities.

~~CONFIDENTIAL~~

~~SECRET~~

CHAPTER 14  
CAREERS IN INTELLIGENCE

A. THE PROBLEM

Why is it customary to think of a "Career in Operations" and a "Career in Intelligence" as differing in opportunities? Ideally, operations and intelligence should be mutually complementary. The best-trained combat crew might be able to navigate accurately to an assigned target and bomb an assigned aiming point with a negligible CEP, but whether or not they evade heavily defended areas en route and avoid ambush by enemy fighters depends on accurate information before take-off. The success of the mission hinges upon other factors also, such as ground maintenance and crew competence, but the contribution of intelligence can hold attrition to a minimum and establish the proper priorities of targets. The guiding concept should be that of an operations-intelligence team effort with equal opportunities to serve and to be rewarded, otherwise an air force becomes all muscles and no mind.

It may be worth while to analyze how successful operations are achieved in order to apply to intelligence the lessons learned. The Air Force has recognized from the outset that, in order to fly aircraft, it must: (1) define the specific jobs to be done by rated individuals; (2) select personnel according to requisite aptitudes; (3) train this personnel to accomplish specialized tasks; and (4) maintain proficiency by periodic checks. This is a process that the Air Force has learned to do well - for operations. The program undergoes continuous scrutiny and review. When new aircraft or new airborne equipment is programed, training programs are initiated so that, when the aircraft and the equipment are received by operational commands, the trained personnel are on the air bases. In a word, nothing is left to chance. The required skill of the B-47 pilot and the "three-headed monster" (navigator, bombardier and radar operator) on his crew are the specialized product of personnel selection and intensive training.

The means employed to insure the competence of rated personnel offers a good guide for treatment of ground personnel, including those in intelligence. The selection and training of maintenance personnel obviously have a direct bearing on the success of all missions by holding "aborts" to a minimum. The extension of these procedures to intelligence would significantly increase the caliber of the intelligence effort, and simultaneously improve the effectiveness of operations.

The selection and training process has been applied in certain specialties, but it has not been applied to an adequate degree for personnel in the collecting and evaluating functions. This is readily understandable. The vast and complicated demands upon intelligence have come about only within the last few years. Overnight, relatively speaking, there have suddenly arisen requirements to collect and evaluate information on a global scale concerning a potential enemy who renders practically impossible the pre-war techniques of data collection.

B. RECOMMENDATIONS

1. Selection and Training for Specialized Tasks

Air intelligence has achieved a major role only since the beginning of World War II. The sudden growth of the Army Air Corps after Pearl Harbor resulted in assignment

~~CONFIDENTIAL~~

~~SECRET~~

of rated personnel to operations, whereas intelligence personnel were recruited almost entirely from civilian ranks. Since the function of intelligence was new, there were no established criteria for selection or training comparable to those of operations. As experience was gained with time, officers with special aptitudes were assigned to jobs for which their civilian background and training were most useful. By the end of the war, the placement of round pegs in round holes began to produce improved performance. Since the end of the war, intelligence has attracted a few officers with combat experience plus specialized aptitudes and skills pertinent to intelligence; but in time of war it is not improbable that even these may be assigned back to operations, thus creating a void to be filled (as in World War II) by earnest but untrained civilians. It is important, therefore, to determine, while there is still time, what analytical qualities and other mental traits are required for specialized intelligence tasks. Where officers now do an outstanding job, the reasons for their performance should be analyzed and recorded so that their competence may be replaced if rotation removes them.

The first step indicated is to recognize that there are specialized intelligence jobs, to compile a list of these, and to select personnel who have the necessary aptitudes. Such a list of specialized intelligence tasks would include (in addition to photo-interpretation which is discussed subsequently) collecting, collating, evaluating, interrogating, and distributing. In the collecting category, there already are detailed instructions for air attaches, and for these a short instruction course is given. This is a good beginning; but since the Air Force cannot tolerate complacency, it must aim at improvement with time. Other categories must be treated in the same manner - deciding what job has to be done, how it can best be accomplished by the minimum expenditure of manpower, and how best to select the most promising personnel. It must be admitted that in many instances intelligence jobs have had a slightly nebulous quality, varying from one command to another. Often, newly assigned personnel have been without previous experience and have had to learn by on-the-job training. As a result, their capabilities vary according to their own zeal or to the infectious enthusiasm of their superior. However, a thorough analysis and definition of tasks, and the selecting and training of personnel to perform them, should contribute immeasurably to more efficient intelligence performance.

The functions of intelligence should be analyzed into the component tasks that require special skills and aptitudes. Personnel should then be selected and trained on this basis. The mating of specialized requirements with specialized personnel is a prerequisite to a satisfactory intelligence product.

## 2. Criteria to Measure Proficiency

Once the tasks have been defined, and the proper personnel selected and trained, there is need for a continuing check on individual proficiency on the job. The analogy to operations is again useful in approaching this problem. The pilot, for example, must pass periodic physical examinations, night flight tests and instrument checks; a minimum number of flying hours is required; his proficiency is under constant scrutiny. The same holds for every combat crew member.

Efficiency records are maintained for intelligence officers, it is true, but

~~CONFIDENTIAL~~

~~SECRET~~

~~SECRET~~

~~CONFIDENTIAL~~

there are no periodic tests comparable to a pilot's instrument check. Why not set up parallel checks to evaluate the performance of an officer in his intelligence specialty? If this were done, it should be possible to detect failure to maintain proficiency, so that responsibility is not vested where it endangers national security. We realize that procedures for assessing the capability of an intelligence officer in his specialty do not come ready-made. They have to be devised by appropriate scientific methods. If such procedures were developed and applied, it would very shortly be realized that intelligence, like operations, expects not only a minimum of competence, but a continuous improvement in performance.

The various means used in industry might be studied and modified in devising a measuring stick for intelligence jobs. As an example, a news reporter on any first-class paper knows that each day he must come back with his shield or upon it. His paper cannot afford to be "scooped" or sued for libel. In some industrial companies, supervisory and executive personnel are given periodic tests. The business world realizes that complacency is the forerunner of bankruptcy, and uses competitive means to insure alertness and to stimulate individual proficiency. Initiative is encouraged and rewarded. Air Force intelligence would benefit by application of these principles.

Criteria should be established for the various intelligence tasks in order to measure individual proficiency and improvement with time.

Perhaps never before in our history has national survival been so largely dependent on a relatively small number of persons charged with collecting vital information and accurately evaluating it. Their capabilities cannot be left to chance. Because of the importance of their task, we must insist upon the highest degree of competence. We cannot afford to neglect this area.

Prior to D-Day, we must rely primarily on collectors and evaluators to insure early warning and to prevent technological surprise; on them we must place much of the responsibility for national survival. There is thus a challenge to our ability to select and train the most suitable individuals. Better to have relatively few individuals - the best in the country - whose judgment we can rely upon, than a host of persons well-intentioned but lacking in aptitudes and training for their specialized jobs. Again, there is a civilian analogy: one top-notch detective and one equally good laboratory technician often solve a problem that baffles a thousand well-meaning but technically untrained policemen. It is the degree of competence that counts.

The Air Force has been quick to utilize civilian techniques and scientific approaches in many of its equipment and management problems. It is highly likely that additional benefits can be derived by studying and adapting civilian techniques from other fields of endeavor. The fitting together of fragments of information, in order to ascertain what the jig-saw puzzle looks like, might yield to the methods employed by the police or by scientific laboratories in working from the known to the unknown. This is not meant to imply that the Air Force is not cognizant of such techniques, but to suggest that valuable advice might be solicited from the F.B.I. and other organizations.

Both journalism and intelligence encounter fairly similar problems in the

~~CONFIDENTIAL~~

~~SECRET~~



~~SECRET~~

~~CONFIDENTIAL~~

collecting of information and the interpretation and evaluation of it under great pressure. Top-flight newspapers, like The New York Times, set an enviable standard in the field of international affairs by their accuracy and speed of transmission. The experience of foreign correspondents of The New York Times in Moscow and Bonn, in addition to that of its local specialists on the U. S. S. R., would be invaluable in any intelligence organization. An analysis of the selection, aptitudes and training of these people might well be a serviceable guide for our own methods of collection and evaluation.

To sum up, operations does an excellent job of flying airplanes under all manner of adverse conditions because nothing is left to chance so far as it is humanly possible; for the sake of the safety of the pilot and his crew - to say nothing of the cost of the airplane and its value as a weapon - specialists are rigidly trained. No other course is possible. In Air Force intelligence, the same policy is essential; the very existence of the nation may depend upon specialized training of its intelligence personnel.

Training of intelligence specialists is necessary if they are to be equal to the crucial nature of their responsibilities.

### 3. Incentives and Rewards in Intelligence

During World War II, the Army Air Corps needed its rated personnel for combat duty, and as a result intelligence officers were recruited from civilian ranks. In many cases, therefore, the vast majority of intelligence officers had no flying experience. It was not unusual for operations to be considered the most important part of the Air Force, with intelligence a not-too-necessary adjunct. Because few intelligence officers were genuinely interested in obtaining first-hand experience, the hazards and problems of combat flying, operations and intelligence were separately compartmented at many headquarters and operational bases. Rated officers with vision are to be highly commended for changing this attitude. But the responsibility for much that remains to be done rests with the individual intelligence officers.

The single-team concept of operations and intelligence - each mutually complementary to the other - will come about only through a better understanding of the interrelation of jobs. It would be highly desirable if every intelligence officer had enough experience in combat-type aircraft to understand the difficulties of the crew member - fatigue, cold, lack of space, poor cockpit illumination, gradual decrease of efficiency on long missions and a host of other problems that must be experienced to be appreciated. This would lead to a better understanding of the end use of combat intelligence and target materials. Since there is no substitute for experience in actual flight operations, there should be a carefully conceived program that would stimulate intelligence officers to obtain at least short-duration, temporary duty with combat units in order to participate in profile missions. Fortunately, at the present time there are at all levels of intelligence many officers with combat experience, so that in combat and reconnaissance wings the briefings (general and specific) are conducted by personnel with an intimate understanding of in-flight problems. This increases the confidence of combat crews, confidence that was often lacking during World War II. As a consequence, intelligence is beginning to enjoy a status approaching that of operations. Only when there is a working partnership will the demarcation between intelligence and operations cease to exist.

~~CONFIDENTIAL~~

202

~~SECRET~~

~~SECRET~~

~~CONFIDENTIAL~~

When intelligence defines more precisely the jobs to be done, selects the best-qualified individuals to perform them, trains them thoroughly, establishes criteria to measure proficiency, and eliminates the incompetents - only then will its officers command the same respect and recognition now rightly accorded those in operations. The sights must be set high if, as we believe, intelligence is to play a major role in national survival. For those who measure up to these high standards, rewarding careers should be open. To the most qualified citizens who apply, we should be able to say, "The Air Force offers attractive careers in operations, and equal opportunities in intelligence. If you have the zeal and the aptitude, and the persistence to undertake rigorous training, you can embark on a career that has no peer. We will not accept every applicant. We will insist on competence, and will disdain mediocrity. We have a single-team concept. Show your worth and your mettle, and you, as an intelligence officer, will achieve stature and status as high as any in the Air Force."

Careers in intelligence should have incentives and rewards comparable with those in operations.

#### C. PHOTO-INTERPRETERS

The foregoing principles apply to all segments of the intelligence function, but they have a particular bearing on the specialty known as photo-interpretation. Not that this is the most important function in intelligence - far from it - but it is an essential function, and one that might assume the aspects of a bottleneck if, at the outset of hostilities, hundreds of airplanes suddenly bring back more thousands of new photographs taken over enemy territory. The best photograph is useless unless interpreted; and, although anyone can look at a picture, the capacity to see what is of military significance derives from a combination of native ability and thorough training.

We believe, therefore, that the Air Force should take steps to insure a supply of competent, enthusiastic photo-interpreters adequate to meet the peak demands of a major war. Among the steps that might be taken we may list the following.

1. Work to improve the competence, morale and status of the photo-interpreter:-

The present group of photo-interpreters constitutes the nucleus around which the specialty must be built. The most competent persons within this nucleus should be rewarded with status and other career incentives commensurate with the crucial nature of their jobs. There should be more of the morale-boosting type of feedback that comes from a photo-interpreter's knowing that the results of his work have been put to successful use.

2. Work to improve the basic knowledge and the working tools available to the photo-interpreter:- Like any technical specialty, photo-interpretation is ripe for improvement through the use of new inventions and new ideas. What helps photography usually helps the photo-interpreter, but some of his needs extend beyond the mere provision of better photographs. He needs what are called "keys" - better ones in fact. He needs the benefits of experiments with different viewing conditions - transparencies versus prints, for example, and with projection techniques that might enable several photo-interpreters simultaneously to view a scene in stereo and to comment on one another's interpretation. Better methods and techniques are especially needed by the radar photo-interpreter - such as improved plotting devices and more realistic

~~CONFIDENTIAL~~

~~SECRET~~

~~CONFIDENTIAL~~

~~SECRET~~

handbooks and other aids for the analysis of typical radar returns.

3. Develop selection tests for photo-interpreters:- If the number of photo-interpreters should need suddenly to be increased, an efficient and valid selection test would be a tremendous asset. The job of the photo-interpreter presumably calls for special talents not possessed by everybody. What these talents are can be determined only by proper study and research. Who has these talents, and how many of their possessors would be readily available to serve in an emergency, can be discovered only after selection tests have been developed. It might turn out, for example, that some aspects of the photo-interpretation task could be better performed by women than men. If this is true, we ought to know it.

4. Set up an adequate training program:- Training is easier if good selection procedures have first been applied, but close attention to a sound training program is certainly needed by the Air Force. The program should be streamlined and efficient, and capable of rapid expansion in an emergency.

5. Provide, through organizational planning, for the optimal use of the photo-interpreters available:- With the growing technical capacities of Air Force photography, there will never be as many photo-interpreters as there are photographs to be looked at - especially come D-Day. How the photo-interpreter is used, where he is located, how he fits in with the flow of information, whether his work gets needlessly duplicated - these are questions that must be faced before the shooting starts. There will be enough photo-interpreters to go around only if they are used with maximal efficiency.

We recommend that the Air Force prepare to meet its potential needs for photo-interpreters by instituting procedures for the selection, training, and efficient employment of the required personnel.

~~CONFIDENTIAL~~

~~SECRET~~

~~SECRET~~

~~CONFIDENTIAL~~

BEACON HILL STUDY GROUP

APPENDICES

to

MAIN REPORT

Appendix A	Organization of the BEACON HILL Study Group
Appendix B	BEACON HILL Briefing Schedule
Appendix C	Problems of the Photographic Method
Appendix D	The Effect of Atomic Weapons on Photo-Reconnaissance Operations
Appendix E	Means for Avoiding Fluctuations of Brightness of the Radar Echo
Appendix F	Cathode-Ray Tube Resolution
Appendix G	Radar Predictions
Appendix H	Radar Reconnaissance in Northern Latitudes
Appendix I	Acoustic Sensing Techniques for Intelligence Use

~~CONFIDENTIAL~~

~~SECRET~~

~~SECRET~~

~~CONFIDENTIAL~~

APPENDIX A

Organization of

BEACON HILL Study Group

- I. CENTRAL STUDY GROUP
- II. LIAISON OFFICERS
- III. CONSULTANTS
- IV. VISITORS' LIST

~~CONFIDENTIAL~~

~~SECRET~~

~~SECRET~~

~~CONFIDENTIAL~~

APPENDIX A  
ORGANIZATION OF BEACON HILL STUDY GROUP

I. CENTRAL STUDY GROUP

James G. Baker	Harvard Observatory
Saville Davis	The Christian Science Monitor, Inc.
Allen F. Donovan*	Cornell Aeronautical Laboratory, Inc.
Gerald K. Geerlings	New Canaan, Conn.
Peter C. Goldmark	Columbia Broadcasting System
R. Joyce Harman	PROJECT LINCOLN
Gilbert W. King	Arthur D. Little, Inc.
Edwin H. Land	Polaroid Corporation
Stewart E. Miller	Bell Telephone Laboratories
Carl F. J. Overhage	Eastman Kodak Company
Richard S. Perkin	Perkin-Elmer Corporation
Edward M. Purcell	Harvard University
Louis N. Ridenour	Ridenour Associates, Inc.
Gordon P. Saville	Maj. General, U. S. Air Force (ret.)
S. Smith Stevens	Harvard University

II. LIAISON OFFICERS

Col. William S. Boyd	Directorate of Intelligence, DCS/O, Hq, USAF
Lt. Col. Paul A. Stears	Directorate of Intelligence, DCS/O, Hq, USAF
James C. DeHaven	Office, Ass't. for Development Planning, DCS/D, Hq, USAF
Lt. Col. Lloyd F. Ryan	Office, Ass't. for Development Planning, DCS/D, Hq, USAF
Lt. Col. Richard S. Leghorn	Wright Air Development Center, USAF

III. CONSULTANTS

William Bolly	Pacific Palisades, California
Charles L. Critchfield	University of Minnesota
Harald T. Friis	Bell Telephone Laboratories
Samuel A. Goudsmit	Brookhaven National Laboratory
Albert G. Hill	Massachusetts Institute of Technology
Edward P. Ney	University of Minnesota
E. R. Quesada	Lieut. General, U. S. Air Force (ret.)
J. Curry Street	Harvard University
Jerome B. Wiesner	Massachusetts Institute of Technology
Jerrold R. Zacharias	Massachusetts Institute of Technology

\*Since 17 March

~~CONFIDENTIAL~~

~~SECRET~~

~~CONFIDENTIAL~~

~~SECRET~~

IV. ADMINISTRATIVE ASSISTANTS

Michael A. Wall

PROJECT LINCOLN

V. VISITORS' LIST

FEBRUARY 1952

Mr. Robert R. Buss

Stanford University

Dr. Howard Cross

Battelle Memorial Institute

Dr. I. A. Getting

Raytheon Manufacturing Company

Prof. Jesse Greenstein

PROJECT VISTA, Calif. Inst. of Technology

Col. Richard Philbrick

A. F. C. R. C.

Dr. E. G. Schneider

A. F. C. R. C.

Dr. Floyd G. Steele

Digital Control Systems, Inc., La Jolla, Calif.

Mr. James S. Thompson  
(Permanent Visitor)

RAND Corporation

MARCH 1952

Lt. Col. R. G. Atwood

A. D. C., W. P. A. F. B.

Col. W. A. Barden

Wright Field, Air Document Office

Mr. W. R. Boario

Aircraft Radiation Laboratory, Wright A. F. B.

Dr. Emmett K. Carver

Eastman Kodak Company, Rochester, N. Y.

Mr. Leo F. Childs

Consolidated Vultee Aircraft Corporation  
Fort Worth, Texas

Prof. F. L. Friedman

Massachusetts Institute of Technology

Mr. L. Goldman

Wright Field, Air Document Office

Dr. George Higgins

Eastman Kodak Co., Rochester, New York

Mr. F. L. Holloway

Aircraft Radiation Laboratory, Wright A. F. B.

Mr. W. S. Ivans

Consolidated Vultee Aircraft Corporation  
Fort Worth, Texas

Mr. A. R. John

Aircraft Radiation Laboratory, Wright A. F. B.

Prof. Joseph Kaplan

Institute of Geophysics, University of Calif.

Mr. Amrom H. Katz

Photo-Reconnaissance Laboratory

Capt. Eugene P. Kiefer

U. S. A. F., Washington, D. C.

Lt. Col. S. H. Kirkland

A. T. I., Air Intelligence, Wright Field

Prof. Charles C. Lauritsen

California Institute of Technology

Mr. J. T. Lawrence

Aircraft Radiation Laboratory, Wright A. F. B.

Capt. Walter J. Levison

Wright Field, Photo Laboratory

Dr. Duncan MacDonald

Optical Research Laboratory, Boston University

Mr. Norman B. Robbins

Consolidated Vultee Aircraft Corporation  
Fort Worth, Texas

Lt. E. J. Ruppelt

A. T. I., Air Intelligence, Wright Field

Dr. Otto Sandvik

Eastman Kodak Co., Rochester, N. Y.

Col. Bernard A. Schriever

Headquarters, U. S. A. F.

Mr. Roderick M. Scott

Perkin-Elmer Corporation, Norwalk, Conn.

Dr. C. W. Sherwin

University of Illinois

~~CONFIDENTIAL~~

~~SECRET~~

~~SECRET~~

~~CONFIDENTIAL~~

MARCH 1952 (cont'd)

Mr. Raife Tarkington

Dr. Mortimer Taube

Mr. C. R. Tieman

Mr. Jack Tupper

Dr. Julian H. Webb

Mr. Frank Willy

Eastman Kodak Company, Rochester, N. Y.

Atomic Energy Commission, Technical  
Information Service, Washington

Research and Development Board, Washington

Eastman Kodak Company, Rochester, N. Y.

Eastman Kodak Company, Rochester, N. Y.

Servo Corporation, New York City

~~CONFIDENTIAL~~

a-5

~~SECRET~~



~~SECRET~~

CONFIDENTIAL

APPENDIX B

BEACON HILL BRIEFING SCHEDULE

CONFIDENTIAL

~~SECRET~~

~~SECRET~~

~~CONFIDENTIAL~~

APPENDIX B  
BEACON HILL BRIEFING SCHEDULE

SPEAKER	SUBJECT
HQ. USAF AT PENTAGON, WASHINGTON                      MONDAY, 7 JANUARY 1952	
Mr. James Doolittle	Welcome and Introduction
Brig. General W. M. Garland	Introduction
Colonel Jack E. Thomas	The Importance of Intelligence to the Users
Colonel Edwin S. Leland	Organization; Functions and Objectives of Air Intelligence
Lt. Col. Peter M. Childress	Collection Procedures
Lt. Col. W. A. Adams, Jr.	Documents and Dissemination
Dr. P. H. Johnstone	Target Programs
Lcdr. Harry Hopkinson	Air Target Objective Program
HQ. USAF AT PENTAGON, WASHINGTON                      TUESDAY, 8 JANUARY 1952	
Col. John G. Erickson	Technical Intelligence
Cdr. A. M. Ellingson	Air Facilities
Col. George P. Gould	Air Order of Battle
Mr. Leslie Rosenzweig	Counter-Atomic Offensive
Mr. John S. Patton	
Mr. Leslie Rosenzweig	
Mr. John S. Patton	Range Extensions
Col. R. E. Leary	
Maj. General D. L. Putt	Introduction
Col. Jack W. Saunders	Air Force Reconnaissance Mission and Objectives
Maj. Richard H. Burnor	Technical Reconnaissance
Col. B. A. Schriever	Strategic Reconnaissance
HQ. USAF PENTAGON, WASHINGTON                      WEDNESDAY, 9 JANUARY 1952	
Lt. Col. P. A. Stears	Radar Reconnaissance and Intelligence I Collection
Mr. F. C. McPeak	Radar Reconnaissance and Intelligence II Utilization
Lt. Col. P. A. Stears	Radar Intelligence Research and Development
Lt. Col. W. R. Harpster	Electronic Reconnaissance
Lt. Col. C. A. North	Aircraft Observer Training in Techniques of Reconnaissance

a-9

~~CONFIDENTIAL~~

~~SECRET~~

~~CONFIDENTIAL~~ ~~SECRET~~

AFTERNOON - ANNEX 3 - PENTAGON

WEDNESDAY, 9 JANUARY 1952

SPEAKER

Mr. Robert C. Sager  
Dr. H. T. Straw  
Photo Analysts

SUBJECT

Photo Intelligence and Interpretation  
Photo Interpretation Research and Development  
Demonstrations of Photo Analysis

HQ. TACTICAL AIR COMMAND, LANGLEY AIR FORCE BASE, VIRGINIA

FRIDAY, 1 FEBRUARY 1952

Maj. Gen. G. O. Barcus  
Brig. Gen. H. L. Sanders  
Colonel J. M. Schweizer, Jr.  
  
Major General E. J. Timberlake  
Lt. Colonel P. F. Sollars

Welcome  
History and Mission of Tactical Air Command  
Intelligence Mission and Organization of  
Tactical Air Command  
Operational Tactical Mission  
Tactical Intelligence in Combat

Major L. R. McKulla and  
Colonel R. A. Berg

Tactical Reconnaissance

Mr. R. P. Crouch  
Colonel K. W. Klise

Tactical Reconnaissance  
Communications Difficulties in Tactical Air  
Operations in Korea

TUESDAY, 5 FEBRUARY 1952

Colonel K. W. Klise  
Lt. Colonel O'Wighton D. Simpson  
Colonel Irving L. Branch  
Captain George J. Keegan

Tactical Air Force Communications  
Intelligence Problems in Korea  
Intelligence Problems in Europe  
Intelligence Problems Confronting TAC

363D TACTICAL RECONNAISSANCE WING, SHAW AIR FORCE BASE

WEDNESDAY, 6 FEBRUARY 1952

Colonel John R. Dyas  
  
Lt. Colonel Cabas

Welcome and Demonstration by Joint Air-  
Ground Indoctrination Team - Base Gymna-  
sium  
Introduction to Static Displays and on Recon-  
naissance

HQ. USAF AT PENTAGON, WASHINGTON

MONDAY, 11 FEBRUARY 1952

Lt. Col. W. W. Shegda

Defector Program

Mr. E. Mayer  
Mr. R. C. Grassy  
Mr. D. B. Dyer  
Mr. A. L. Canfield

Target Division Presentation

~~CONFIDENTIAL~~

a-10

~~SECRET~~

~~SECRET~~

~~CONFIDENTIAL~~

HQ. USAF AT PENTAGON, WASHINGTON

MONDAY, 11 FEBRUARY 1952 (cont'd.)

Lt. Col. W. Hammond

Organization of the Aeronautical Chart and Information Service

Mr. C. F. Arlosky

Charting Development and Design

Mr. C. H. Heller

Air Information Collection and Dissemination

Mr. W. Mussetter

Geodesy

Mr. B. B. Lane

Photogrammetry

Mr. A. R. Materazzi

Cartography

ARMY MAP SERVICE, WASHINGTON

TUESDAY, 12 FEBRUARY 1952

Mr. D. Y. Hovsepian

Introduction

Col. J. G. Ladd

Mapping and Intelligence Missions and Responsibilities of the Corps of Engineers

Mr. D. Y. Hovsepian

Flow of Intelligence and Information, and Requirements for Intelligence Operations

Capt. A. P. Colvocoresses

Problems in Mapping and Engineer Intelligence Operations with Certain Suggested Improvements

Dr. F. Betz

Group Presentations on Processing and use of Information and Intelligence

Mr. C. Iseminger

Mr. H. Wilcox

Mr. P. Alexander

Mr. Frank Bloom

Mr. F. Hough

Mr. J. P. Webb

U. S. NAVAL PHOTOGRAPHIC CENTER, NAVAL AIR STATION, ANACOSTIA, D. C.

Capt. J. A. Ruddy, USN

Introduction and Welcome

Mr. A. C. Lundahl

Introduction to Naval Photographic Interpretation and General Consideration of the P. I. Problem

LCDR R. N. Colwell, USNR

Basic Consideration of Technical P. I. Problems

LCDR R. DeLancie, USNR

Basic Consideration of Non-Technical Problems in Photo Interpretation

LCDR F. J. Brazil, USN

Welcome to P. I. C.

Mr. C. G. Coleman

Photographic Interpretation

Mr. I. T. Walters

Photogrammetry

LCDR R. H. Baist, USNR

Technical Services

Mr. J. W. Gardner

Training Departments

WRIGHT AIR DEVELOPMENT CENTER

MONDAY, 14 JANUARY 1952

Maj. Gen. Fred R. Dent, Jr.

Welcome

Col. R. L. Johnston

The Systems Approach

~~CONFIDENTIAL~~

~~SECRET~~

~~CONFIDENTIAL~~

~~SECRET~~

WRIGHT AIR DEVELOPMENT CENTER

MONDAY, 14 JANUARY 1952 (cont'd.)

Lt. Col. R. S. Leghorn  
Lt. Col. R. G. Atwood  
Capt. B. Bayuk  
Lt. Col. A. T. Phillips

WADC Approach to Research and Development  
in Intelligence and Reconnaissance  
Major Problems of Terrain Intelligence  
Drone Aircraft  
SNARK

Lt. Col. H. T. Neal

Major Problems in Atmospheric Intelligence  
and Climatology Briefing

Maj. M. C. Chase  
Lt. Col. A. T. Phillips  
Maj. J. A. Boykin  
Capt. H. F. Wienberg

GOPHER  
Strategic Reconnaissance Systems  
Strategic Aircraft  
Tactical Reconnaissance Systems and Recon-  
naissance Fighter Types  
Reconnaissance Bomber Types  
Corps-Division Support Types  
Guidance Systems  
Data Correlation

Maj. J. A. Boykin  
Capt. C. W. Kuehne  
Mr. L. Showen  
Capt. P. L. Deimling

TUESDAY, 15 JANUARY 1952

Brig. Gen. Gordon A. Blake  
Col. G. W. Goddard  
Capt. W. J. Levison  
Mr. J. S. Goldhammer  
Capt. W. J. Levison  
Capt. N. L. Sternberger  
Lt. Col. E. D. Jones  
Mr. C. J. Marshall  
Mr. C. J. Marshall  
Mr. C. Colbert  
P. E. Hockman  
Dr. P. J. Ovrebo

Introduction  
Photographic Reconnaissance  
Photographic Equipment Developed for Air-  
borne Intelligence Systems  
Equipment Developments for Data Conversion  
Systems  
Summary  
Atmospheric Reconnaissance (Airborne and  
Ground)  
Ferret Reconnaissance  
Radar Reconnaissance  
AN/APQ-45  
RPI (Radar Presentation Intelligence)  
IBDA (Indirect Bomb Damage Assessment)  
Infrared

WEDNESDAY, 16 JANUARY 1952

Col. Frank L. Dunn  
Maj. Spencer Whedon  
Lt. Col. W. L. Ewbank  
Mr. Egan D. Foy  
Maj. John E. Libbert  
Col. Frank L. Dunn

Welcome and Introduction  
Standard A-2 Briefing  
Collection  
Aircraft Analysis  
Electronic Reconnaissance  
Closing Remarks

~~CONFIDENTIAL~~

a-12

~~SECRET~~

~~SECRET~~

~~CONFIDENTIAL~~

OHIO STATE UNIVERSITY

Professor George H. Harding  
Dr. J. Allen Hynek  
Dr. Fred P. Dickey  
Mr. John R. Williams  
  
Dr. W. A. Heiskanen  
Mr. Walter D. Lambert  
  
Mr. W. O. Byrd  
Dr. Earl Church  
Mr. O. M. Miller  
Dr. N. T. Bobovnikoff

WEDNESDAY, 16 JANUARY 1952

Welcome and Introduction  
Missile Aspect and Sky Outlines  
Mapping and Charting by Radar  
Shoran Applications to Mapping and Charting

The Gravity Program of the Laboratory

Geodetic Studies  
Photogrammetry  
Cartographic Presentation  
Russian Science and Cartographic Intelligence

HQ. STRATEGIC AIR COMMAND OFFUTT AFB

MONDAY, 28 JANUARY 1952

Gen. Curtis E. LeMay  
Col. J. H. Walsh

Mission of SAC  
Target Array, Order of Battle and Target Materials

Maj. Gen. J. B. Montgomery

SAC - Command and Control - Current Training and Operations - Bombing Accuracy Trends - Typical Mission Planning

Col. J. H. Walsh  
Col. W. R. Yancey  
Lt. Col. R. Triantafellu  
Col. J. B. Bestic  
Lt. Col. L. J. Israel  
Col. A. W. Nielsen

Collection and Distribution System  
Operations of the SAC Reconnaissance Force  
SAC Bombing Problems  
Electronic Counter Measures  
Electronic Equipment  
New and Improved Equipment

28th STRAT. RECON. WING (H)  
RAPID CITY AFB

TUESDAY, 29 JANUARY 1952

Col. R. E. Ellsworth  
Lt. Col. R. Taylor  
Lt. Col. C. H. Royce  
Capt. O. S. Moore  
Lt. Col. G. T. Hicks  
Maj. J. L. White  
Capt. R. R. Crusey  
Capt. D. A. Hollander

Welcome  
Combat Crew Briefing  
Static Display  
Take-Off and Film Drop Demonstration  
Tour of Laboratory and Film Evaluation  
Laboratory  
Display Room  
Reproduction Section

HQ. EIGHTH AIR FORCE, CARSWELL AFB

WEDNESDAY, 30 JANUARY 1952

Maj. R. P. Lukeman

Eighth Air Force, Briefing Demonstration of a Typical Mission

Demonstration of ECM (Ferret) Equipment in a B-50

Demonstration of Ultrasonic Radar Bombing Trainer, and New Experimental Cathode-Ray Tubes

a-13

~~CONFIDENTIAL~~

~~SECRET~~

~~SECRET~~

~~CONFIDENTIAL~~

APPENDIX C

PROBLEMS OF THE PHOTOGRAPHIC METHOD

~~CONFIDENTIAL~~

~~SECRET~~

~~SECRET~~

~~CONFIDENTIAL~~

APPENDIX G  
PROBLEMS OF THE PHOTOGRAPHIC METHOD

A. INTRODUCTION

Since 1945, a number of important papers and reports have been written by research workers in the United States, England and Canada on the subject of photographic resolving power, contrast and graininess. The problem is a broad one, and involves the observer, means of observation and a number of physical parameters that are difficult to disentangle from one another. However, progress is being made toward an understanding of the photographic image and there is growing agreement among different workers on various aspects of the problem.

It is encouraging that since 1945 the problems of aerial photography have become more widely recognized in the Air Force. It is debatable, however, whether any real and lasting improvements not already obtained by 1945 have been made in actual results. The number of workers in the field has increased considerably, but there has not as yet been a noticeable increase in average picture quality. Much has been accomplished in the study of the limitations and capabilities of standard equipment in the range from 6- to 24-inch focal length, but there has been no appreciable advance in the quality of the equipment itself. Culmination of instrumental developments initiated some years ago may indeed bring about improvements in time. However, when we visit the operational reconnaissance bases, we find about the same equipment that was used in 1945.

There has been marked progress since 1945 in the direction of the large and specialized cameras, but it is debatable, if a choice had to be made, whether this work should have taken precedence over improvement of standard equipment. Ideally, both developments should have been carried out, which means that the smaller equipment should have come in for more attention. This is the case with the 6-, 12-, and 24-inch cameras, and partly the case with the 36-inch f/8 telephoto. At present, the lenses have to be stopped down to give adequate performance, and then the increased exposure time leads to enhanced image motion and vibration.

It still seems to be true that a combination of a heavy camera (large moment of inertia), high shutter speed, and sharp-focus lens produces first-quality aerial photographs, in spite of the large volume of work done on mount characteristics, image motion, haze, contrast, laboratory tests, etc. This means that to date the "brute force" solution is still effective, and that we have not as yet brought our accumulated knowledge to bear on improved mounts and image-motion compensation. The work in progress along these lines should be encouraged, with the goal of getting the results into production and into mass use by the reconnaissance wings.

Enough information is now on hand to enable one to make a careful assessment of any given situation in aerial photography within the light of available photographic materials and processing. It may be that discovery of a different photographic material could revolutionize aerial photography where the problems of speed, contrast and graininess are liquidated all at once. We do not have such a solution nor does the shadow of one hover on the

~~CONFIDENTIAL~~

~~SECRET~~



~~CONFIDENTIAL~~ ~~SECRET~~

horizon. In its absence we must plod along with slow improvements in lens quality, mounts, and shutters.

#### B. LENS QUALITY

In the present practice of aerial photography, the conclusion has been reached from time to time that the quality of existing lenses does not represent an important limitation to the effectiveness of aerial photography. In the large, where one considers data handling and photo-interpretation, such a conclusion is probably correct. In the small, the conclusion needs modification.

Inadequate test data exist on the effect of imperfect lens quality on microscopic contrast and on the recognition of details in the fading-out region of microscopic contrast,\* where a good lens should make a real difference - that is, at a level of, say, 15 lines/mm - the imperfect lens may present a washed-out image of a tank which in itself is of low contrast, whereas the good lens at 15 lines/mm may still give enough contrast in the image of the tank to permit recognition. These considerations will be discussed in Section D below.

The existing 6-, 12-, and 24-inch lenses at full aperture do not represent the practicable limit of lens quality, though they may indeed represent the most economical limit in cost per lens. However, an increase in complexity may result in lowered production. The writer believes that if a factor-of-two improvement could be worked into each design, in terms of microscopic contrast at a level of 25 lines/mm, a great deal of good would be accomplished in raising the average level of performance on good photographic days. On poor days, not much can be accomplished with present emulsions. The question is whether for a few per cent increase in cost per lens and for a few per cent lowered production, we might not achieve a better balance in our standard product. On good days, perhaps a 30 per cent improvement in microscopic contrast could be achieved at a level of 20 lines/mm, an improvement that would result in quicker and easier recognition of details at this level.

One needs only to compare a lens bench test of the standard 24-inch at  $f/6$  with the 36-inch telephoto at  $f/8$  to see that there is a real difference in image quality. It should be possible to obtain a 24-inch  $f/6$  lens with images over the  $9 \times 18$  format not too far different from those provided by the 36-inch  $f/8$  telephoto, which in itself is not a lens of the highest quality. The same holds true for the 12-inch  $f/5$ , namely, that a marked improvement is feasible with care exercised in design.

The point here is that at a print level of 5 lines/mm, observed without magnifying glass, the difference in microscopic contrast between a good lens and bad lens may be unnoticeable. At 10 lines/mm, the good lens may continue to give good microscopic contrast, whereas the bad lens may already start to show washed-out images. At 15 lines/mm, the good lens may begin to fail, owing primarily to printing losses, while the bad lens has ceased to resolve and the microscopic contrast is zero.

---

\*The term "microscopic contrast" receives a full treatment in Sec. D. Here we can consider that the expression refers to the density difference in the image on the emulsion, at the resolution level cited, between highlight and lowlight.

~~CONFIDENTIAL~~

~~SECRET~~

~~SECRET~~

~~CONFIDENTIAL~~

If we transfer these observations to a positive transparency and omit the printing on paper, we probably would find the deficiencies of the bad lens more pronounced relative to the good lens, though the positive transparency will show improved results for both lenses. Now, it may be that at 25 lines/mm the good lens may still be showing some resolution of low-contrast targets, whereas the bad lens may show only targets of high inherent contrast. At 30 lines/mm, the good lens may be beginning to fail on even the high-contrast targets, whereas the bad lens may have ceased to perform.

What are the conclusions to be reached? We can say that, if we are interested in a quality level of only 10 lines/mm on good days for targets of intermediate to high contrast, existing lenses are good enough. If we are interested in a quality level of 20 lines/mm on good days for the same targets, then existing lenses need improving at full aperture, though they may be adequate when stopped down to  $f/8$ . If we are ever to be interested in a quality level of 30 lines/mm for intermediate to high contrast targets, then existing lenses will have to be improved markedly.

The above discussion is not intended to indicate that we can achieve any drastic reduction in size of equipment by an improvement in lens quality. While a reduction of the order of 30 per cent might be achieved if all days on which pictures are taken were good days, the fact is that on many days, especially in Europe and in the U.S.S.R., there will be haze and inherently poor target contrast. Under these conditions, the requested improvement in lens quality will be wiped out by low resolution and low microscopic contrast of the emulsion itself at the low target contrast produced by the haze. Here, focal length itself becomes more important than lens quality.

There is a very natural tendency for all of us to show only our best work, and this applies to organizations as well as to individuals. Yet, if we are to establish a factual frequency distribution for the resolution and microscopic contrast of aerial photographs, we must deal with the worst as well as the best. Accordingly, we should do some aerial testing on bad and on very bad days as well as on good days. Some thought should be given to assigning a quality rating to a photographic situation in the air and marking this on the prints along with other data. Thereafter, we should know what to expect in resolution and contrast at different altitudes and with different cameras on days of varying quality index, and on different kinds of targets.

Figure C-1 shows a plot of expected size of recognizable objects on the ground plotted against focal length for photography at 50,000 feet. The full curve is drawn through points plotted on the basis of expected results in the air across the line of flight for the different focal lengths of existing equipment. The 40-inch  $f/5$  is known to give a peak of about 25 lines/mm at an altitude of 10,000 feet, which here is assumed to be about 22 lines/mm at an altitude of 50,000 feet. The standard 24-inch under the same conditions is assumed to give a peak to its frequency distribution (not the highest value) of about 14 lines/mm under the same circumstances. The 60-inch  $f/6$  telephoto is assumed to give 22 lines/mm. The 96-inch  $f/8$  is assumed to give 14 lines/mm on the average, the 144-inch  $f/9$  also gives 14 lines/mm and the 240-inch 10 lines/mm. The 12-inch  $f/5$  is assumed to give 15 lines/mm, and the 6-inch 12 lines/mm (full aperture).

~~CONFIDENTIAL~~

a-19

~~SECRET~~

~~CONFIDENTIAL~~ ~~SECRET~~

An assumed rule, that it requires four lines of resolution to yield recognition of the object of plotted size at the threshold of the resolving power observed, is used in Fig. C-1. Thus, if the observed threshold is 24 lines/mm, the size of the object as plotted subtends an angle equivalent to 6 lines/mm or 0.167 mm divided by the lens focal length, or has a ground size equal to 0.167 mm times the scale. If the limiting resolution is 12 lines/mm, one uses 0.333 mm times the scale, etc. This rule is only an approximation, but for the purposes at hand it suffices.

The crosses in Fig. C-1 represent the limit to improvement that might be obtained by improving the lens design within feasible limits. The circles represent what might be expected by improving both the lens design and the mounting or antivibration characteristics, and/or shutter speed. The first fine-dashed curve represents the situation at low contrast, as on poor photographic days, and/or poor target contrast. This curve is determined by the condition that the threshold, more or less independent of focal length, is set by haze and low target contrast to a level of 5 lines/mm. The size of object is determined by the same rule used before, namely, that it requires four lines of resolution contained within the object for recognition to be established. The curve represented by a coarse-dashed line indicates the situation on a very bad photographic day with thick haze, or could represent the situation for high obliques from high altitude (transverse object at 50,000 feet in line of sight) on even fair photographic days. Here, one can expect from Boston University results that more lines per object are required to establish recognition. This curve indicates why the 100-inch camera is useful for high obliques and why the 240-inch camera penetrates near-horizon haze to considerable distances.

The curves demonstrate that an increase in focal length overcomes increase in quality to an extent dependent on quality of the existing lenses and on the day. On good days, for a given ground recognition, one can use equipment of moderate size. On bad days, it is necessary to resort to a longer focal length to observe the same object. One lays a horizontal line across the graph to see the change in focal length required.

The full curve in Fig. C-1 between 48-inch focal length and 240-inch focal length is based on operation of the cameras by trained observers. Experience indicates that, if routine observers are used with this large equipment, the corresponding curve lies higher on the diagram in the general direction of the fine-dashed curve, except that the full curve fairly well represents results obtained by such routine observers up to 36-inch focal length. Accordingly, routine observers require longer focal lengths to achieve a given level of results; conversely, trained observers can get by with smaller equipment, or can accomplish much more with the large equipment.

If we choose our equipment on the basis of the fine-dashed curve, then we are likely to recognize the ground detail of indicated size. A true "factor of safety" would go according to this dashed curve, if we are always to bring home the bacon. However, in most cases we are not too sure as to what ground detail we may wish to recognize, or, at least, have not been instructed along these lines. Such an obscurity removes the zero point of the diagram, and we simply work on the basis of bringing home whatever results the day permits. On good days, a given large camera may give a superfluity of information. On bad days, a

~~CONFIDENTIAL~~

~~SECRET~~

~~SECRET~~

~~CONFIDENTIAL~~

small camera may abort the mission.

In the absence of specific requirements for a mission on which a factor of safety may be determined, one should be prepared to "waste film" in the interest of avoiding an aborted mission. The cost of film is small compared to the costs of plane, mission, and men's lives. Film becomes dear only if in short supply at the base, or if used in excessive quantities beyond even the dictates of a prudent factor of safety.

We are under no moral obligation to develop or to examine all the film that may be exposed on a mission. Thus, if a photographic day turns out to be first-rate, one may find all the information needed on a 6-inch roll. There would then be no need to process a 12- or 24-inch roll taken on the same mission. The roll can be stored for a limited period of time and then destroyed. However, if the 6-inch roll fails to give the results, which may be anticipated ahead of time if the quality index for the day is bad, then one might decide to process the 12- or 24-inch roll. The idea that we must process and print whole rolls of film, without any need for them, ought to be discouraged. If we can safely omit exposing the roll to begin with, so much the better. Here, common sense applies. An RB-36 with only 3 rolls of film taken on a million-dollar mission on only 6-inch equipment might be an abortion an expensive failure. Here we can safely take along many rolls of film, and expose according to the weather and judgment of the trained photographer. Similarly, we can easily imagine a photographic compartment on a guided missile that by sheer necessity has only a single camera and a single roll of film. Here we must gamble results against choice of the novel installation and vehicle.

In Fig. C-1 we see that the curves rise steeply for the short focal lengths. The plots have deliberately been made on a linear basis to emphasize the losses in going to the shorter focal lengths. Thus, in going from 3 to 6 inches, or from 6 to 12 inches focal length, we obtain a drastic increase on the curves in terms of ground resolution. At a given altitude, the peak of the frequency distribution of ground details of interest may already have been passed in going from 6 to 12 inches. In going to 24 inches, we may be starting to look for a relatively few objects, and the law of diminishing returns will have set in. In going to 48 inches or to even greater focal lengths, we may be interested now in only a few small objects of importance. Or, if we go to twice the altitude, such as 40,000 instead of 20,000 feet, the increase in focal length may be needed if we are to stay on the desired side of the frequency distribution of ground object size.

No one can determine accurately in advance what the limiting smallness of details is to be, for this depends on the mission. If the purpose of the mission is assigned, then one can determine the focal length likely to be needed. However, too small a focal length - except where it is made mandatory by space limitations - is likely to produce inadequate results for the expended effort.

Figure C-2 represents an approximate plot of equipment cost against focal length. The crosses represent actual known costs, which scatter around a lot, owing to special attachments, format size, shutter type, image-motion compensation, etc. The curve attempts to be a mean curve through averaged complexity of equipment. Here we assume that control boxes are necessary for the medium as well as for the large cameras. We see again that, in the range from zero to twelve inches, not much is gained by miniaturization of focal length

~~CONFIDENTIAL~~

~~SECRET~~

~~CONFIDENTIAL~~

~~SECRET~~

alone. The law of diminishing returns sets in on Fig. C-1 in the direction of very short focal length and inadequate ground-detail recognition, and in Fig. C-2 in the direction of long focal length and great size and costs. Thus, these curves point to the fact that moderate focal lengths yield the biggest returns, and that neither extremely miniature equipment nor excessively large equipment is desirable for mass usage. The very large cameras and lenses thus belong in the special operations field where the peculiarity of the mission demands and justifies their use.

Likewise, it is very easy for inadequately trained personnel to misuse the large cameras. At least, conditions of use may prevent proper focus and proper pre-flight maintenance. All these factors argue against having the large cameras in ordinary use, and experience has borne this out.

It is to be concluded, therefore, that focal lengths from 6 to 36 inches are practicable for mass usage in the Air Forces, and that larger equipment should be reserved for special missions, operated by special personnel in suitable planes. There is a need for a 70-mm film camera for low-altitude sweeps, where larger film is superfluous for most purposes, and where the modern need for high recycling times dictates the use of this narrow film. However, for high-altitude work, resort to 70-mm film where 9-inch film can be used is not to be encouraged, save where space limitations are severe (see Chapter 5).

One could plot a frequency distribution of the industrial output of this country in terms of dollar costs and camera size. We do not have the industrial capacity at the present time to produce as many as three 240-inch cameras a year, nor is such production necessary. If we set out to manufacture three such cameras, we can do so only by diverting industrial skills from more desirable channels or by a special training effort with a large lead time. This same effort, again, might be more profitably employed. Our financial resources are not unlimited, and we must have a clear idea of reconnaissance needs before undertaking production of too many large cameras.

A moderate peripheral program can be accomplished quite successfully with a half-dozen cameras of 100-inch focal length. It may be that for such purposes three 240-inch cameras will be adequate. Equally important, it may be that a reduction in size of camera for long oblique work becomes feasible without sacrificing focal length. Or, if the dollar cost can be lowered drastically by a better design of equipment, then the long focal length lenses may become more practicable. The law of diminishing returns must be kept under control. It will do no good to have equipment folded up with many mirrors, if the mirrors vibrate unduly, or are warped, or become too dusty.

#### C. EMULSIONS

We are still looking for the high-speed, grainless emulsion with good microscopic contrast, an emulsion that may revolutionize aerial photography and that may at last enable small equipment to accomplish what we now can obtain only with large equipment. Until this happens, we must consider what can be done with emulsions as we know them.

At present we have an approximate relation between speed, microscopic contrast and graininess. On the one hand, we have a fairly grainy emulsion like Super-XX, and

~~CONFIDENTIAL~~

~~SECRET~~

~~SECRET~~ ~~CONFIDENTIAL~~

on the other a fine-grain slow emulsion like Microfile, with many others scattered in either direction. We know that the needs of the Air Force require standardization so far as possible, and that photography under service conditions must often be attempted in poor illumination. Thus far, Super-XX appears to be a workable compromise on the basis of speed, graininess, and other characteristics. In time, more research on emulsions may lead to a film with the same speed and with other properties improved.

It has not as yet been determined to the satisfaction of the writer that, for special missions or under special circumstances, a resort to an emulsion like Microfile might not have special advantages. Current information goes all the way from drastic quantitative arguments against the feasibility of using a Microfile-type emulsion with perfected camera equipment and short focal length\* to instructive photographs made with extremely short focal lengths on a much grainier emulsion. Work carried on at the Boston University Physical Research Laboratories indicates that, from an information content point of view, the use of Pan-X over Super-XX offers appreciable advantage. This work, while extensive, shows the need for an even more elaborate study of different emulsions under varying circumstances.

The present distribution of use of Tri-X Pan for night photography, Super-XX for general use, infrared film and color film is not too far from the best compromise. Any benefits brought about by improved emulsions for the same purposes, or by improved developing methods, or indeed any improvements that can be passed along routinely to the user in the field without complicating his problems, are to be encouraged. Any increase in the variety of emulsions or elaboration dependent on the user ought to be discouraged or examined with the greatest of care. Special emulsions and special methods in general ought to be reserved for the specialized units described in Chapter 12.

#### D. MICROSCOPIC CONTRAST

Discussions of microscopic contrast have arisen a number of times in the BEACON HILL Study Group, owing to the importance of this subject in connection with picture quality. The terms macroscopic contrast, microscopic contrast, resolution and graininess are so entangled as to require some treatment all at once.

It is not intended to ignore the important contributions to the above considerations made by a large number of skilled research workers here and abroad. But this Report is not the place for a prolonged and objective discussion of photographic details done better elsewhere.\*\* The mission of BEACON HILL is to suggest how reconnaissance and intelligence can be improved. In the photographic problem, there is some possibility that an improvement in microscopic contrast by development or printing methods may bring about increased information content in aerial reconnaissance, or make it possible for the average photo-interpreter to achieve results heretofore impossible, or accomplished with difficulty by the very best

\*According to several workers, an improvement in graininess and microscopic contrast by a factor of two may correspond to a loss of speed by a factor of between 50 and 500.

\*\*For example, the Research Laboratories of the Eastman Kodak Company have introduced a new function called "acutance" which gives an extremely high correlation with picture quality or sharpness in psychophysical tests. Acutance goes beyond contrast alone and considers both functional edge contours and density range. Acutance does not include graininess.

~~CONFIDENTIAL~~

~~SECRET~~

~~SECRET~~

~~CONFIDENTIAL~~

photo-interpreter.

In discussing contrast, we must introduce the term "macroscopic contrast," which means the contrast of large photometric areas on the emulsion. We can consider that an area of a square 2 mm on a side is large enough to give a contrast not measurably different from a much larger area on the film. In principle, however, we do mean that "macroscopic contrast" refers to the contrast of very large areas, where for present purposes we can consider the term contrast to refer to density differences in the photograph.\*

The term "microscopic contrast" refers to the density difference of small detail on the emulsion. More specifically, we can consider microscopic contrast as the density difference at any given line number  $N$ , where  $N$  is the number of lines per millimeter. For large detail, where  $N$  is one or even less, the microscopic contrast becomes identical with macroscopic contrast. At some limiting value of  $N$ , depending on the emulsion, lens, target contrast, exposure, development and to some extent grain, and the method of reduction, microscopic contrast goes to zero. In practice, on such an emulsion as Super-XX this limiting number can be as large as 90 lines/mm where perfected procedures are employed.

The problem must also include the term "target contrast," which here refers to the equivalent macroscopic contrast that would be observed on the emulsion in terms of density difference, if haze were absent, and if the target were large enough to image into macroscopic areas on the photograph. As the target size diminishes, we have only to keep the actual reflectivity factors of high- and lowlights unaltered to be able to assign to the target a value for its target contrast.

Intervening haze will superimpose itself onto the target contrast. The direct light from the ground target will be attenuated by the scattering in the atmospheric haze-producing layers, and then the effective brightness of the haze itself will superimpose more or less uniform stray light onto the photograph. Exposure control can still cause macroscopic areas of a given brightness, as seen by the lens, to be photographed at a constant macroscopic density. The net effect thereafter will be a reduction in the contrast at all levels of resolution from the macroscopic areas to the microscopic. By contrasty development, one can restore the macroscopic contrast to the level that would obtain in the absence of haze, as measured again by density of macroscopic areas, but in so doing the microscopic contrast is only partially restored. Because the threshold of resolution so far as the emulsion is concerned is a function of threshold contrast and graininess, loss of microscopic contrast produced by haze causes an inevitable loss in resolution. However, it takes a substantial amount of haze to lower the limiting resolution drastically, and the curves relating contrast to resolution are well known. At resolution levels well above the resolution threshold, the loss of microscopic contrast causes a loss in picture quality. A loss of picture quality reduces the probability of recognizing a given small detail - the loss depending on the size of the detail to be recognized and on the level of resolution. Studies at Boston University show that, for the same microscopic contrast, more resolution lines per object will again increase the probability of recognition.

\*Contrast is defined in a number of different ways such as  $E_2 - \log E_1$ ,  $I - I_0/I_0$ , etc. Here we wish to stay close to emulsion properties after development.

~~CONFIDENTIAL~~

~~SECRET~~

For a constant level of resolution on the emulsion, this means that, as the object grows larger at a given poor microscopic contrast, leading to more lines in the object, the probability of recognition is increased. In the limit, a large object has a 100 per cent probability of recognition if there are enough lines in the object at the assigned level of resolution and contrast above threshold values. This in turn means that if the photograph is of low quality, due to haze, low target contrast, poor lens, or a combination of these factors, an increase in scale will improve the probability of recognition. Hence, a long focal length lens at a given altitude, producing a large scale, makes it easier for photo-interpreters to recognize their ground detail. If we consider that there is an "average quality" aerial photograph a photo-interpreter is justified in concluding that recognition of any given object depends on scale. In turn, if we have a better lens, producing good microscopic contrast at a given scale and resolution level, a given ground object requires fewer lines per object to be recognized, or in general the probability of recognition for a given number of lines per object (of the order of 2 to 6 lines per object) is improved. It is clear that the simple expedient of increasing the number of lines per object to obtain recognition when the microscopic contrast is low cannot go on indefinitely, and the observed curves do show a limiting contrast below which no increase in lines per object can do any good. Moreover, it is also clear that recognition of an object, as contrasted with detectability, must require a certain minimum number of lines per object where context, observer skill and pre-knowledge are ruled out, even when the contrast is excellent. Boston University curves show here a value as low as 1.3 lines per object, but there is given only a 50 per cent probability of recognition, along with an uncertainty in establishing the probability at this low value and with a known dependency on the type of object, the nature of which is known to the observer. For Super-XX and a 100 per cent probability of recognition, it still requires about 5 lines per object. In this connection, Pan-X is demonstrably superior to Super-XX in requiring only about 2.5 lines per object under similar excellent conditions. Extension of these results to targets more or less unknown to the observer, or present in such variety as to prevent guessing, may produce somewhat different values. Presumably, it requires more lines per object to recognize an unknown type of object from among many possibilities than to distinguish between two possibilities of a simple kind of target. However, Pan-X ought to remain systematically superior to Super-XX.

In the case of most entities of complex construction, recognition must depend on a minimum number of so-called recognition factors, which in turn require a certain detectability each to serve in the context. A recognition factor may require several lines within itself to be recognized of itself. In context, detectability of the recognition factor alone may serve its purpose as a recognition aid for the larger entity. Some entities may be recognizable on the basis of a single recognition factor. Other entities may require a number of recognition factors. In many cases, pure detectability combined with location will serve to establish recognition, in which case the detectability becomes a recognition factor for the larger entity.

For example, a blur on a highway may safely be determined to be a vehicle. The same blur on an airport runway is likely to be an airplane. If one needs to know what kind of vehicle or what kind of airplane, more lines per object must be obtained to establish recognition, in which the recognition factors of the object play their role anew.



~~CONFIDENTIAL~~

~~SECRET~~

In the above discussion, there appears a justification for the choice of a long focal length lens to produce a scale large enough to render a given object recognizable at a given altitude. These factors are consistent with the curves drawn in Fig. C-1 from another point of view. If a day is bad, producing low microscopic contrast, then an increase in focal length will render the ground detail more readily recognizable at the expense of coverage.

There is still another possible factor perhaps overlooked by many workers in the field. Only provisional data are at hand, and it is recommended that quantitative studies be made on the point. Recently the workers in Canada scanned ground detail from the air in an attempt to examine the frequency of occurrence of different target contrasts on good photographic days. The results indicated that low contrast predominates as a rule. The workers concluded that lenses should be tested at low contrast, inasmuch as their results "proved" that aerial photography is inherently of low contrast.

Now, these results are valid so far as they go, but they are really a part of a larger pattern. The Canadian workers used a fairly large integrating solid angle of the order of 3' of arc. The writer feels that more prolonged aerial tests should use a variety of well-selected integrating spots on the ground with curves of frequency distribution drawn for each size of scanning spot or aperture. The underlying belief here is that, as the scanning spot grows smaller, the peak of observed frequencies of ground-target contrast moves toward larger target contrast values. There is no real limit to the smallness of the scanning spot, and in our daily lives we observe quite excellent contrast in the small objects around us, even excepting color contrasts. On the other hand, if we use a larger scanning spot than the Canadians used in their 3' angle, we should expect the peak of the frequency distribution of contrasts to move toward still smaller contrast values. If the spot on the ground is quite large, then all the details of such an object as a house would average out, and houses as a class of objects would show only a slight variation in contrast.

The writer believes that this effect shows up subjectively in our customary comparisons of photographs made with large and small lenses. The large-scale photographs may seem contrastier or snappier than the small-scale, quite apart from other differences - that is, in addition to the ability to recognize objects because they are comfortably above the emulsion limit and show a better microscopic contrast with the larger scale picture, we have a greater abundance of contrasty objects because of the smaller scanning spot related to the angular resolution of the larger lens. All these factors tend to favor the lens of long focal length. The 240-inch lens from high altitude appears to give quite a good contrasty picture on vertical shots over city areas where small objects of high contrast abound. A 6-inch lens from the same altitude would fuse together these small objects. The grosser details left in the picture that can be distinguished on the average are of lower contrast. The 6-inch picture, apart from other reasons, then gives a "flatter" photograph. It is recommended that these considerations be examined quantitatively by means of scanning with varying integrating spots or apertures.

There are various ways to depict the effects of microscopic contrast and resolution. A way preferred by the writer involves the use of pseudo-microphotometer tracings. These are tracings made by hand to illustrate what a density microphotometer (i.e., with

~~CONFIDENTIAL~~

~~SECRET~~

~~SECRET~~ ~~CONFIDENTIAL~~

logarithmic amplifier) would show under various conditions with the corresponding type of photography.

We visualize a test target of the picket-fence type, consisting of long lines in a geometrical progression of decreasing width and spacing, all the way from quite wide lines to very narrow lines. This target is photographed according to the test conditions of contrast, exposure, emulsion, lens, and even motion. We imagine that we make a microphotometer tracing of the picket-fence photograph.

Figure C-3 shows a tracing where recorded density is plotted against resolution in lines per millimeter. Let us suppose that we have a "perfect lens-film combination" along with maximum target contrast (emission lines on an opaque background so exposed as to lead to a density range of zero to two). Now, if we have a microphotometer slit of length just short of the length of the lines and perhaps 10 mm long, and a slit width of perhaps 0.010 mm, we would obtain a tracing as shown in Fig. C-3(a). Because the integrating slit is very long, the statistical fluctuation of the grains is minimized. The tracing goes up and down between the envelope lines and is quite smooth, owing to the absence of graininess. The limit of resolution occurs at perhaps 50 lines/mm, where the amplitude of the fluctuation goes below the visual threshold for the residual graininess that appears. Presumably, with an extremely long slit and great amplification in the photometer, one could follow the resolution down to finer lines. However, for a slit of the order of 10 mm long and 0.010 mm wide, graininess will still appear slightly.

Figure C-3(b) shows what happens if we scan with a short slit also 0.010 mm wide. Here there is considerable graininess, enhanced by the small slit area. Consequently, there is much random fluctuation superimposed on top of the real lines. At a level of 37 lines/mm, the eye fails to distinguish the reality of the lines because of the graininess. Even at much coarser levels of resolution, the tracing looks bad though resolved.

Figure C-3(c) shows a situation similar to what occurs in practice. Here, the microphotometer slit has a variable length and a variable width where both are a function of resolution number. At 5 lines/mm, the slit is 0.500 mm long and 0.100 mm wide. At 25 lines/mm, the slit is 0.100 mm long and 0.020 mm wide. At 50 lines/mm, the slit is 0.050 mm long and 0.010 mm wide. Thus, the graininess exhibited in the tracing grows rapidly and, in fact, about as the square of the resolution number. Our standard three-line pattern has a constant ratio of 5:1 in length over width and spacing of lines. As the pattern grows smaller, the requirements on resolution are affected more and more by the graininess. The tracing of Fig. C-3(c) is intended to illustrate the rapidly increasing demands on the emulsion as the target disappears into the grain. In actual aerial photography, we have an analogous situation when the image of the ground target disappears into the grain or into other sources of limitation on resolution.

All the remaining figures are to be considered as having a scanning slit with height and width a function of resolution as in Fig. C-3(c). Figure C-3(d<sub>1</sub>) shows the case of "imperfect lens-film" for infinite target contrast, where macroscopic areas are geared to a density range of zero to two. The lens imperfections cause the image contrast to pass the threshold about at 28 lines/mm which becomes the resolution limit. Note that at the level of 10

~~CONFIDENTIAL~~

~~SECRET~~

lines/mm the microscopic contrast is already lowered to about 70 per cent that at 10 lines/mm in Fig. C-3(c). Hence, the imperfect lens has already caused a loss in limiting resolution and a loss all down the line in microscopic contrast. Moreover, although graininess is not pronounced at 28 lines/mm, it still interferes with resolution, inasmuch as the ratio of contrast to grain is unfavorable. Figures C-3(d<sub>2</sub>), (d<sub>3</sub>) and (d<sub>4</sub>) show the corresponding situations for different emulsions.

Figure C-3(e) shows the case of "perfect lens-film" but with much reduced target contrast. So far as the emulsion is concerned, the effects are quite similar to a loss of contrast caused by an imperfect lens. The microscopic contrast is lowered and is low anyway because the target contrast is low. The limiting resolution in the figure is 22 lines/mm, and the effects of graininess are slight. The low-target contrast may be either inherent in the target or caused by overlying haze. If the latter, the photograph would profit by a contrasty development and contrasty printing, where the macroscopic contrast might be restored to a density range of zero to two. If this were to be done, the resulting tracing would resemble Fig. C-3(d) - that is, we might consider that in these two cases an imperfect lens on a good day (d<sub>1</sub>) would give similar results to what a perfect lens might give on a bad day, (e) the latter being given contrasty development.

Figure C-3(f) shows a tracing for an "imperfect lens-film" on low target contrast, produced either by low inherent target contrast or by overlying haze on a contrasty target, or both. The resolution is only 16 lines/mm and the contrast poor. Now, if the target contrast is known to be good so that contrasty development is justified, we see that, if macroscopic contrast is increased to a density range of zero to two, the microscopic contrast will be dropping in the resolution range from 5 lines/mm to the limit of 19 lines/mm.

Figure C-3(g) shows the case of Fig. C-3(d<sub>1</sub>) with very contrasty development in an attempt to recover microscopic contrast. The density range is now zero to three, and the microscopic contrast at about 15 lines/mm is back to normal with a density range from 0.5 to 2.5 or 2 altogether. The other microscopic contrasts are off-scale in both directions now, and the photograph will not appear to be of pleasing quality.

The various figures show that the microscopic contrast of the good lens stays well above that of the imperfect lens, even though in the limit the resolution compares only as 42 to 28 lines/mm. At a level of 15 lines/mm in Figs. C-3(c) and C-3(d<sub>1</sub>), the microscopic contrast of the imperfect lens is only 35 per cent of the perfect lens. Recognition of targets at the 15-line level favors the good lens in two ways: (1) the better contrast for a given number of lines per object increases the probability of recognition; (2), the better contrast requires fewer lines per object at a given probability of recognition. Then, too, for a given object size, the good lens can lead to recognition of ground objects of lower contrast, whereas the bad lens must be confined to showing only ground objects of good contrast.

Figure C-3(h) shows a tracing for an underexposed target. Here the resolution is limited to about 32 lines/mm where there are too few grains to form an image. Figure C-3(i) shows a tracing for an overexposed target. Here the scattering into the spaces limits the resolution to about 22 lines/mm, and the photograph is of poor quality. Graininess is still of no great importance, although the picture may be unsightly because of the high density. (Note

~~SECRET~~

~~CONFIDENTIAL~~

that the ratio of graininess to microscopic contrast still sets the limiting resolution observed.)

The remaining figures make use of only the envelope lines where one supposes still that the tracing has been made. Figure C-3(j) reproduces Figure C-3(c), and in addition shows the desired envelope curves where the microscopic contrast has been restored by some as-yet-unknown development method. The resolution cannot be recovered at the threshold, but over most of the range an improvement in microscopic contrast will lead to more easily recognized objects. In addition, the photograph will appear to be of greatly enhanced quality and will admit of more satisfactory enlargement.

Figure C-3(k) reproduces Figure C-3(e). In addition, the microscopic contrast has been adjusted by a presently unknown development method. Where the target contrast has been lowered by haze, another envelope curve is shown where the haze has been eliminated. Figure C-3(j) is far better than Fig. C-3(k), but such is the damage caused by haze with present emulsions.

Figure C-3(l) shows a case of "perfect lens-film" with a target of low inherent contrast and with overlying haze. Here the new envelope lines show an elimination of the haze and improved microscopic contrast.

Figures C-3(j), (k) and (l) are all idealized, because as yet we have no known means for improving the microscopic contrast in the way that is desirable. There are electrical methods known in television where such is possible, and television pictures of improved quality have been obtained in such a manner. Possibly one could devise a television method of printing, but we run into drastic new dangers in any such device. There may be printing techniques on special printing papers that could offer a solution. Most desirable would be a method of development that would cause macroscopic areas to be brought to a full density range for the film (which would eliminate haze for these areas), and with microscopic contrast improved as a function of resolution in the desired way. It is to be noted that, in any such technique, the graininess must not be enlarged if satisfactory results are to be obtained in the fine lines.

It is recommended that research be conducted into the nature of any and all techniques that would improve microscopic contrast while holding macroscopic contrast at proper values. If this could be achieved, there would be an immediate improvement in photo-interpreter speed, accuracy and output, and an increase in the effectiveness of standard equipment. One could expect that microscopic contrast to a level of 15 lines/mm would be preserved and that the standard aerial photograph would take on an impression of high quality. Similarly, pictures made on good photographic days by good lenses would be extraordinarily fine.

Since we are asking for an unusual improvement in photographic techniques, we should point out the need for a method of reducing graininess. Here it would be desirable to replace a single heavy grain by scattered finer ones of equivalent area. Statistical smoothing would preserve the resolution, and at the same time the microscopic contrast should be adjusted. If everything could be done at once, the aerial photograph would become a greatly improved tool.

All these things point to the need for continued research on emulsions and development techniques, as well as research on printing methods. Elsewhere, there are recommendations being made as to emulsion research for other purposes. A single general recommendation is that active researches should be carried on toward an improvement in the photo-

~~CONFIDENTIAL~~

~~SECRET~~

graphic method, where the needs of aerial photography are kept uppermost in mind.

Figure C-3(m) shows the envelope curves for a perfect lens at best focus, and again for an imperfect lens focused on the one hand for best resolution and on the other for best contrast. It is to be noted that at 10 lines/mm, the focal position for best contrast gives a much superior picture in terms of "quality" than at the focal position for best resolution. However, the Boston University results indicate that the focal position for best resolution will yield more information, in spite of the lowered picture quality. Here we have a case where a bad-looking photograph gives more results for the desired purpose than the good-looking photograph. On the other hand, if there is much haze and lowered threshold resolution on this account, then at 10 lines/mm the focal position for best contrast might yield more information return, that is, the microscopic contrast at this level would permit recognition of many targets that at lower contrast might be lost.

Figure C-3(n) shows the case of a "perfect lens-film" for different focal settings. Here we see that the position of best resolution is also systematically the position of best microscopic contrast, and that there is a steady progression of both toward low values as the lens is placed more and more out of focus.

Figure C-3(o) shows a similar case for an "imperfect lens-film". Here the imperfection in the lens leads to a crossing-over of the positions of best threshold resolution and best contrast. Position 3 is the best for microscopic contrast at a level of 13 lines/mm. The dashed curve shows what an adjustment of microscopic contrast could do to the photograph. It is to be noted that, if microscopic contrast values are to be improved by a special method, the lens should be focused for best resolution (Position 1).

In the presence of image movement and vibration limitations on resolution to the level of 13 lines/mm, it would appear that Focal Position 3 might lead to better results at the present time.

Figure C-3(p) shows the case of "spurious resolution" and what happens when the microscopic contrast is adjusted. Spurious resolution is caused by an harmonic agreement of frequencies in the line pattern with image errors, where in many instances lines and spaces are interchanged. In elaborate forms, one may go through spurious resolution twice at different levels.

Figure C-3(q) shows the case of focusing of a "perfect lens-film" for low target contrast. Figure C-3(r) shows the case of focusing of an "imperfect lens-film" for low target contrast. By adjusting microscopic contrast as indicated by the dashed line, one can recover some of the quality of the photograph despite all the underlying difficulties.

The adjustment of microscopic contrast appears to imply the necessity for control over the contrast at any given resolution level. Thus, at present we adjust the macroscopic contrast by development. If we are to adjust the relative microscopic contrast in addition, Figs. C-3(j), (k) and (r) indicate that different degrees of control are needed for the microscopic contrast according to the target contrast and resolution level. This is asking quite a lot of research in this field, but anything in the right direction would be a help. Research on microscopic contrast or, more particularly, on acutance, microscopic contrast and graininess, will pay big dividends in improvements in aerial photographs, over and above other

~~SECRET~~  
~~CONFIDENTIAL~~

improvements brought about by better lenses, better mounts, etc., desirable as the latter are,  
and will add to the speed and accuracy of the photo-interpreter output.

J. G. Baker

a-31 ~~CONFIDENTIAL~~

~~SECRET.~~

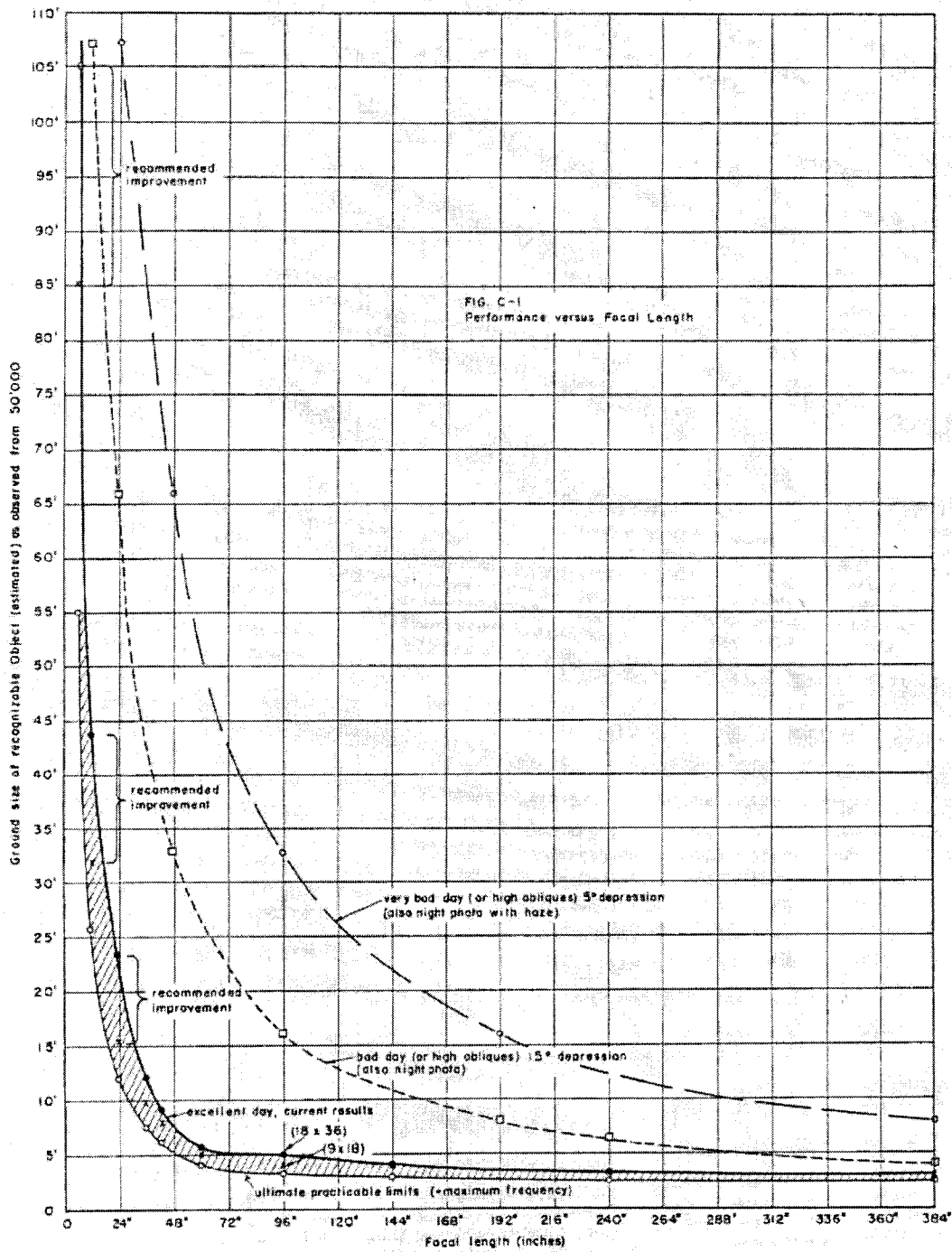

Fig. C-1. Performance versus focal length.

~~SECRET~~

CONFIDENTIAL

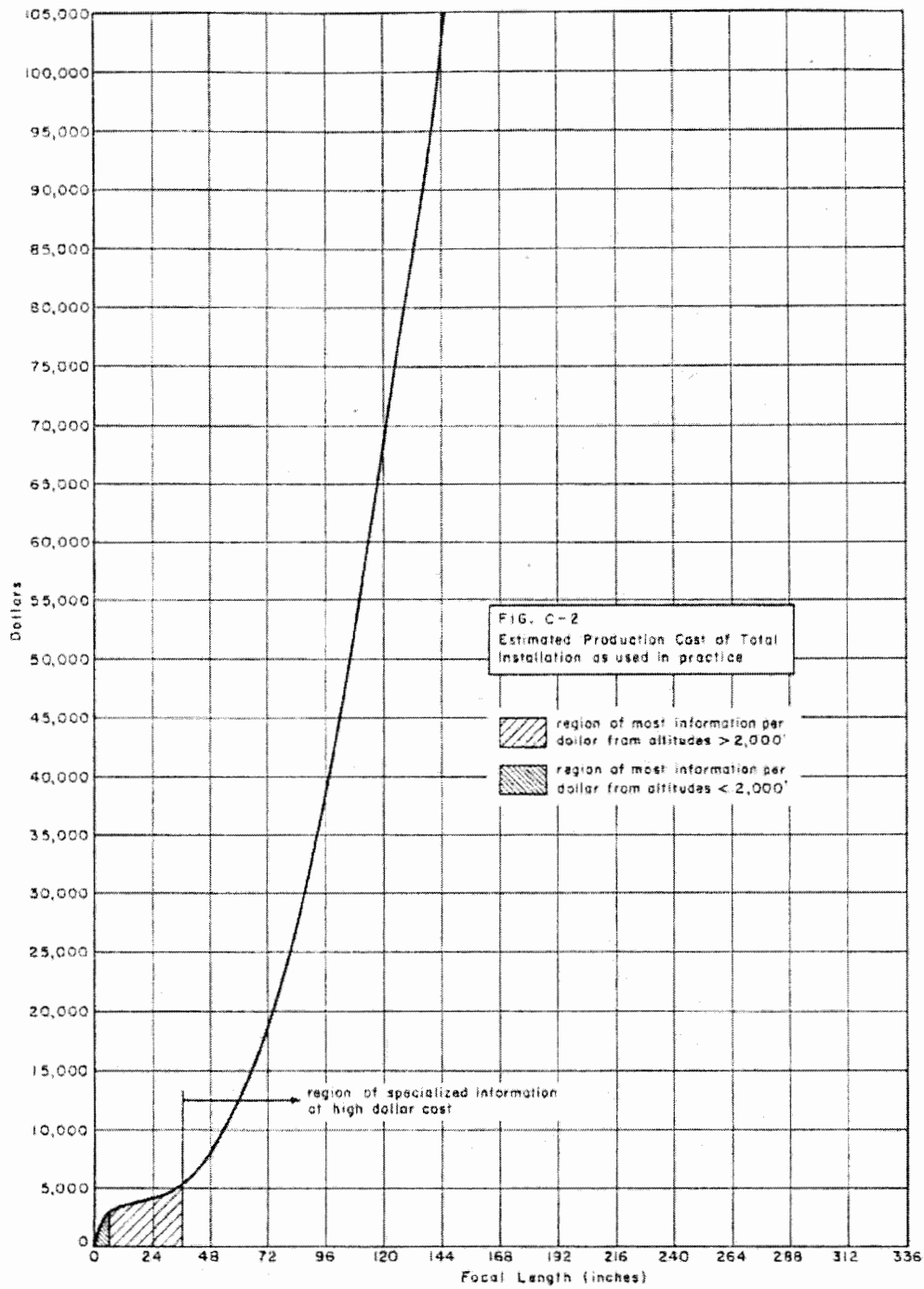
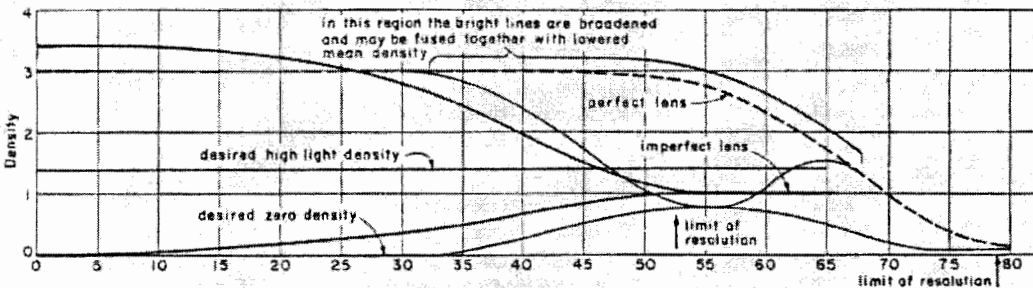
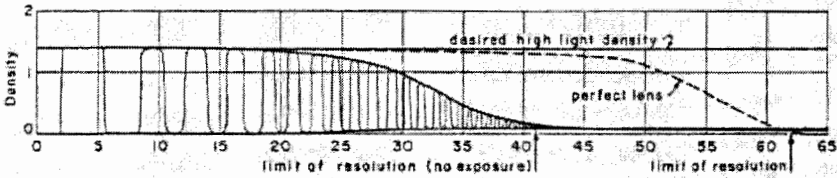
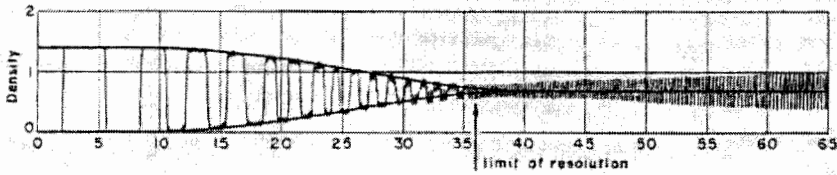
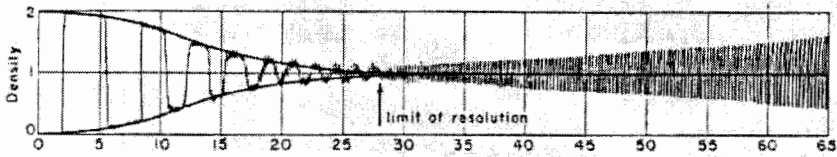
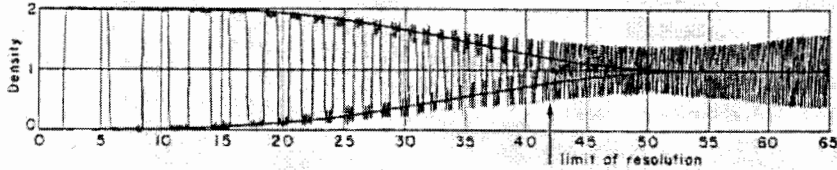
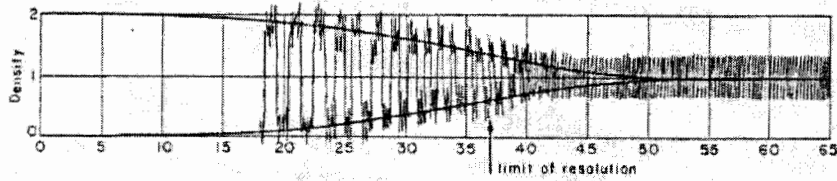
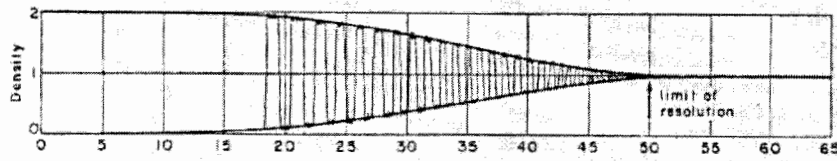

Fig. C-2. Estimated production cost of total installation as used in practice.

CONFIDENTIAL

~~SECRET~~





~~SECRET~~

~~CONFIDENTIAL~~

Fig. C-3(a). "Perfect lens-film,"  
maximum target contrast, scanning slit  
length 10 mm, scanning slit width 0.010  
mm, Super-XX.

Fig. C-3(b). "Perfect lens-film,"  
maximum target contrast, scanning slit  
length 0.050 mm, scanning slit width  
0.010 mm, Super-XX.

Fig. C-3(c). "Perfect lens-film,"  
maximum target contrast, scanning slit  
length  $5/2N$  mm, scanning slit width  
 $1/2N$  mm, Super-XX.

Fig. C-3(d<sub>1</sub>). "Imperfect lens-film,"  
maximum target contrast, scanning slit  
length  $5/2N$  mm, scanning slit width  $1/2N$   
mm, Super-XX.

Fig. C-3(d<sub>2</sub>). "Imperfect lens-film,"  
maximum target contrast, scanning slit  
length  $5/2N$  mm, scanning slit width  $1/2N$   
mm, Panatomic-X, optimum exposure.

Fig. C-3(d<sub>3</sub>). "Imperfect lens-film,"  
maximum target contrast, scanning slit  
length  $5/2N$  mm, scanning slit width  $1/2N$   
mm, Microfile, exposed for macroscopic  
areas.

Fig. C-3(d<sub>4</sub>). "Imperfect lens-film,"  
maximum target contrast, scanning slit  
length  $5/2N$  mm, scanning slit width  $1/2N$   
mm, Microfile, exposed for microscopic  
areas.

~~CONFIDENTIAL~~

~~SECRET~~

~~CONFIDENTIAL~~

~~SECRET~~

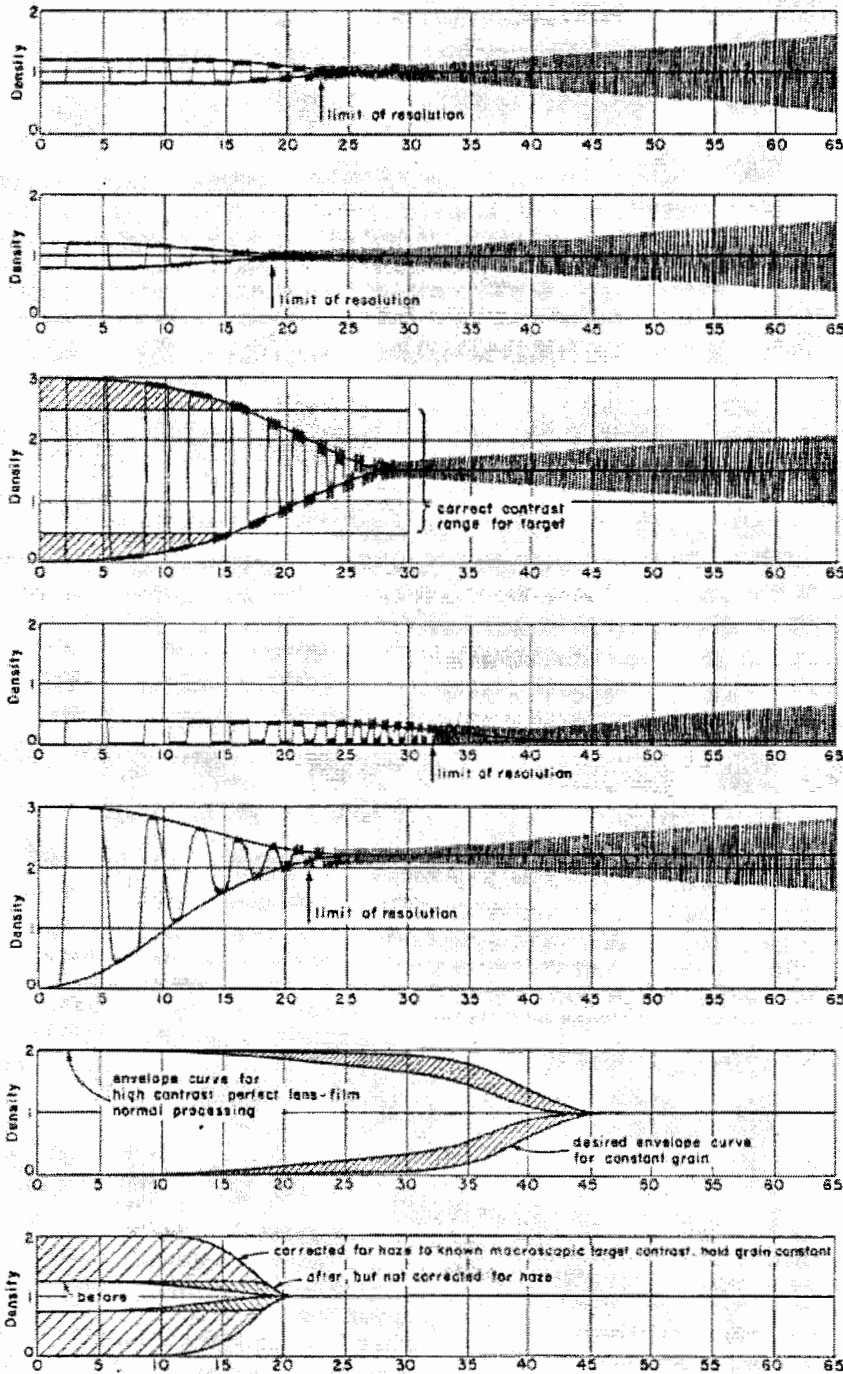

~~CONFIDENTIAL~~

~~SECRET~~

~~SECRET~~

~~CONFIDENTIAL~~

Fig. C-3(e). "Perfect lens-film,"  
low target contrast, scanning slit length  
 $5/2N$  mm, scanning slit width  $1/2N$  mm,  
Super-XX.

Fig. C-3(f). "Imperfect lens-film,"  
low target contrast, scanning slit length  
 $5/2N$  mm, scanning slit width  $1/2N$  mm,  
Super-XX.

Fig. C-3(g). "Imperfect lens-film,"  
maximum target contrast, contrasty devel-  
opment, compare figure C-3(d<sub>1</sub>), Super-XX.

Fig. C-3(h). "Perfect lens-film,"  
maximum target contrast, Super-XX,  
under exposure.

Fig. C-3(i). "Perfect lens-film,"  
maximum target contrast, Super-XX,  
over-exposure.

Fig. C-3(j). "Perfect lens-film,"  
compare figure.

Fig. C-3(k). "Perfect lens-film,"  
case of maximum target contrast, plus  
overlying haze, Super-XX.

~~CONFIDENTIAL~~

~~SECRET~~

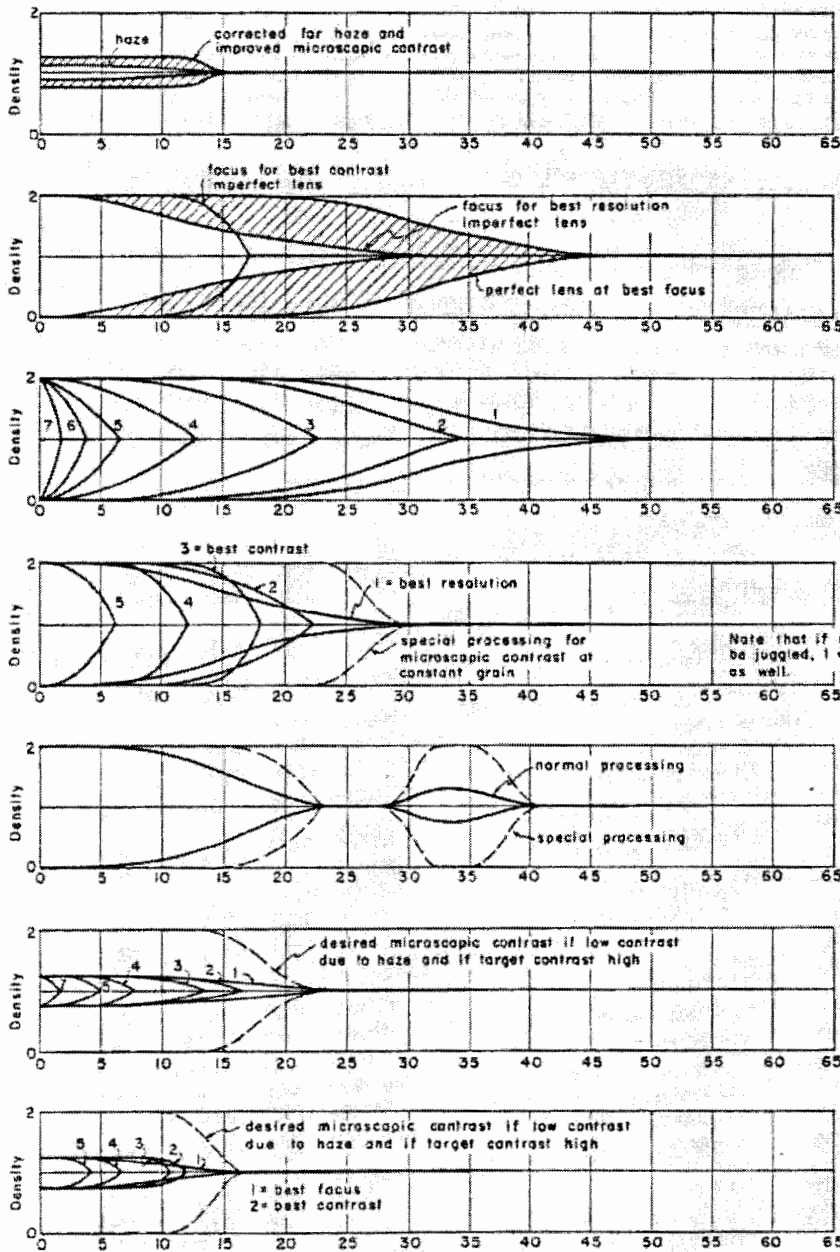

~~SECRET~~

~~CONFIDENTIAL~~

Fig. C-3(l). "Perfect lens-film," case of low target contrast, and overlying haze.

Fig. C-3(m). Comparison of perfect lens-film with imperfect lens-film, the latter of two focal settings, resolution 42:28,  microscopic, contrast improvement.

Fig. C-3(n). Case of perfect lens at different focal settings.

Fig. C-3(o). One side of focus only. Imperfect lens.

Fig. C-3(p). Case of spurious resolution.

Fig. C-3(q). Perfect lens of low target contrast, different focal settings.

Fig. C-3(r). Imperfect lens at low target contrast, different focal settings.

~~CONFIDENTIAL~~

a-39

~~SECRET~~

~~SECRET~~

~~CONFIDENTIAL~~

APPENDIX D

THE EFFECT OF ATOMIC WEAPONS  
ON PHOTO-RECONNAISSANCE OPERATIONS

~~CONFIDENTIAL~~

~~SECRET~~

~~SECRET~~

~~CONFIDENTIAL~~

APPENDIX D  
THE EFFECT OF ATOMIC WEAPONS  
ON PHOTO-RECONNAISSANCE OPERATIONS

Recent advances in the production of atomic weapons suggest the possibility that, in a future war, a hundred or more atomic explosions may occur within a few days' duration. The sensitivity of photographic materials to radiation from radioactive substances is well known, and the question has been raised\* whether photo-reconnaissance operations will still be feasible in a period following the large-scale release of atomic weapons.

The hazards of radioactive contamination have been considered for three situations in which photographic operations may be seriously endangered:

- (1) An aircraft passing near the point of release shortly after a bomb has exploded;
- (2) A forward reconnaissance base in a theater of operations in which atomic weapons are employed;
- (3) A manufacturing plant producing photographic materials.

1. Aircraft Near Ground Zero

An aircraft passing near or through the cloud of radioactive materials produced by an atomic explosion is exposed to serious radiation hazards. Experiments made in conjunction with past tests of atomic weapons have yielded usable photographs on normal negative materials exposed in drone aircraft passing through the cloud a few minutes after the explosion. In a number of tests, film left on the ground in locations considered too dangerous for human operators showed no noticeable radiation damage. In other cases, some increase in fog level was noted, but this effect was prohibitively large only in cases where radioactive debris from the primary fallout acted on the film for several hours before it was recovered. This additional hazard does not arise in an aircraft passing near the explosion.

While these experiments suggest that bomb-damage-assessment and other types of aerial photography will be feasible from aircraft close (in space and time) to an atomic explosion, it must be borne in mind that the tests were not specifically designed to test photo-reconnaissance procedures.

We recommend that carefully planned operational experiments in aerial photo-reconnaissance be performed in connection with future atomic test explosions to determine what materials and procedures are least susceptible to radiation damage.

Such tests should include not only measurements of radiation effects on camera film and control samples placed in the aircraft, but also work done by photo-interpreters

\*The study group is especially indebted to Mr. David T. Griggs, Chief Scientist, USAF, who repeatedly pointed out the importance of this question. A quantitative study of the problem has also been urged in the report of PROJECT VISTA, Series A, Vol. 1, p. 253.

~~CONFIDENTIAL~~

~~SECRET~~



~~CONFIDENTIAL~~ ~~SECRET~~

to find out how the actual usefulness of reconnaissance photographs is affected by increments in the fog level of the negative material.

## 2. Forward Reconnaissance Base

The photographic material stored and handled at a forward reconnaissance base will be subject to contamination from the radioactive particles carried in large numbers by the air and by the water. The selection of storage facilities and the distribution of film supplies in a theater of operations should be planned with this danger in mind.

The worse effect will be encountered where these particles are permitted to act on sensitized goods over long periods. Raw film should therefore be kept in airtight containers; in the absence of efficient air filters, any radioactive dust settling on the outside of such containers should be promptly removed. Magazines and cameras must be kept dust-free, and special efforts may be indicated to enforce cleanliness in loading rooms. Doubtful film should be checked immediately before use by processing small samples.

Particles carried in the supply of water used for film processing are less dangerous because of the relatively short time in which they can act on unexposed silver halide. The larger particles will be removed by the normal water filters employed to protect the processing system from ordinary dirt.

Constant awareness of the danger of radioactive contamination is the first and most essential step toward adequate protection of reconnaissance in forward areas.

Personnel responsible for photographic operations should be indoctrinated with respect to the hazards of radioactive contamination. Frequent tests of the level of radioactivity should be encouraged, and the necessary monitoring equipment should be made available.

## 3. Photographic Manufacturing Plants

The presence of radioactive material in a photographic manufacturing plant is especially dangerous because any radioactive particle introduced into the film or its wrapping materials will remain in contact with the film for the long interval between its manufacture and use. The total effect will be integrated by the photographic emulsion, and the cumulative damage will be severe even from exceedingly low levels of radioactivity.

Radioactive fallout from the atmosphere after atomic explosions in the past has given rise to some difficulties in photographic manufacture, but the measures necessary to control these difficulties are becoming better understood. At the levels at which radioactive debris has so far been encountered, the industry will probably be able to safeguard its products against prohibitive damage.

Extrapolation to the very much higher levels that may be encountered after large-scale use of atomic weapons is necessarily uncertain, and, in the absence of any actual experience under such conditions, there has been some concern over the industry's ability to maintain continuous production of sensitized materials for vital military and civilian needs. A

~~CONFIDENTIAL~~

~~SECRET~~

~~SECRET~~

~~CONFIDENTIAL~~

recent Staff Study\* on this problem points to the fact that the radioactive debris from atomic bomb explosions is concentrated in particles that can be efficiently removed by current filtering procedures, so that an increase in the number of explosions, and thus in the number of particles, may not be disastrous. However, it may become necessary in periods of very high activity to relax current quality standards and to tolerate a higher incidence of spots on film.

It may also be necessary in such situations to resort to changes in packaging procedure. Radioactive contamination of packaging materials has been one of the most troublesome problems faced by the photographic industry. Large quantities of water are used in the manufacture of packaging materials at many widely separated mills, so that radioactive debris carried down by precipitation has an excellent chance of showing up as a contaminant in paper and cardboard. A control program of considerable magnitude is necessary to keep such materials from being used in film packaging.

None of the precautions that have been outlined will protect the manufacture of photographic materials from the effects of nearby atomic explosions. Even in the absence of direct damage from blast, lengthy interruption of manufacturing schedules must be expected after the detonation of atomic bombs within a radius of a few miles from a photographic plant. The logistic impact of such interruptions can be absorbed to a considerable degree by proper planning of the distribution of raw film supplies within the Air Force.

C. F. J. Overhage

---

\*The Effects of Long-Range Airborne Atomic Bomb Debris on the Photographic Industry, AFSWP-102, Staff Study by CDR. G. W. Johnson, USN, 25 Sept. 1951, with Addendum dated 4 January 1952 (Secret, AEC Restricted Data).

~~SECRET~~

~~CONFIDENTIAL~~

~~SECRET~~

~~CONFIDENTIAL~~

APPENDIX E

MEANS FOR AVOIDING  
FLUCTUATIONS OF BRIGHTNESS OF THE RADAR ECHO

~~CONFIDENTIAL~~

~~SECRET~~

~~SECRET~~

APPENDIX ~~CONFIDENTIAL~~  
MEANS FOR AVOIDING

FLUCTUATIONS OF BRIGHTNESS OF THE RADAR ECHO

The fluctuations in brightness of the target return which are prevalent in present-day radars introduce a confusing factor at minimum, and probably reduce the ability of the radar observer to absorb the information that is present on the average. Rapid-scanning systems are, as a matter of fact, being suggested for use by SAC in order to overcome this difficulty. In this Appendix we consider what can be done about this.

All the schemes for overcoming target-echo fluctuation reduce ultimately to the use of a wider band of frequencies for the determination of the position of the target in space. Several methods of using the wider-frequency band will be indicated, along with some of the merits and demerits of the various proposals.

In present-day radar, a single frequency carrier is amplitude-modulated on and off to form a pulse which is the transmitted signal. One way of reducing target fluctuation is to retain this same system of modulation, but transmit a shorter pulse. Then the desired signal return may be resolved from interfering signal returns, thereby removing the sources of variation on the desired signal. This approach has the advantage that better resolution is obtained, as well as reduction in target fluctuation. There is a very serious disadvantage in that much higher peak powers are required. This follows as a consequence of the fact that it is necessary to maintain the average power radiated the same in the short-pulse or long-pulse system in order to keep approximately constant the ability to detect targets. The shorter-pulse system, therefore, obviously must transmit much higher peak powers.

Another method of using a broad frequency band for the reduction of target fluctuation is to use frequency modulation during the on-time of the pulse. In such a system, the amplitude and frequency characteristics of the signal may be as sketched in Fig. E-1. In this arrangement, the pulse width is not shortened but there is contained within the signal the equivalent information of the shortened pulse. This may be demonstrated as follows. Suppose we pass the frequency-modulated pulse (Fig. E-1) through a delay equalizer as sketched in Fig. E-2. The characteristic of the delay equalizer is sketched in Fig. E-3. What we wish to do is to delay the energy components that are emitted during the first portion of the pulse, at frequency  $f_1$ , by a greater amount than the delay that we give to the frequency components  $f_2$  that are emitted at the end of the pulse. The net result is to "pile up" the energy from all portions of the pulse into a shorter period of time. As a result, the broad pulse, containing frequency modulation at the input to the delay equalizer, is transformed into a much shorter pulse at the output of the delay equalizer. This demonstrates that the frequency-modulated pulse is equivalent to a much shorter pulse. In a radar system, the transmission path from the transmitter to the target and back to the receiver is entirely linear. Therefore, it is possible to put the delay equalizer of Fig. E-2 in the receiver rather than in the transmitter. Thus it is possible to emit a relatively low peak power and still obtain the performance characteristics associated with a much higher peak power pulse of shorter duration. These pulse-shortening principles have been demonstrated in the Radio Research department of the Bell Telephone Laboratories.

~~CONFIDENTIAL~~

a-49

~~SECRET~~

This particular system will tend to overcome target-echo fluctuation and, at the same time, give higher resolution. Further, it does not require high peak power to obtain these characteristics.

A third possibility is to employ as a carrier an amplitude waveform that has the character of random noise. By so doing, there will be no coherence between the various portions of the pulsed waveform, and it will not be possible to produce severe interference effects on combining several such signals. A rough approximation is given in Fig. E-4. To maintain good signal-to-noise characteristics, it is necessary to use as a carrier a band of "noise" several times broader than the bandwidth associated with the waveform of the amplitude-modulating pulse. In this arrangement, there is no increased resolution available from the use of the additional bandwidth, but the echo fluctuation should be greatly reduced. Although a random waveform has been assumed here, it is probable that no very important change in the character of the system performance would appear from limiting the peaks of the waveform to a considerable extent. Therefore, it may be that the peak power required from the transmitter in the "random" carrier case need not be appreciably higher than that required when using a sine-wave carrier as is present practice.

It may be possible to build a radar of the type indicated above by using a frequency-modulated magnetron. On the other hand, it may prove very desirable to take advantage of the broad frequency band characteristics of the traveling-wave tube and, perhaps, to use an oscillator-amplifier combination for the transmitter. Certainly, this combination offers the advantage of a great deal of flexibility not present with the self-excited oscillator. This leads to the question of high-power traveling-wave tubes. It is possible to build a traveling-wave tube that will deliver peak powers of the order of 100 kilowatts or more, and average powers of the order of several hundred watts. Some attention is already being given to the problem of developing such a tube, but this program would probably benefit from the guidance of specific ideas backed up with experimental work on how such tubes would actually be employed to best advantage in a radar.

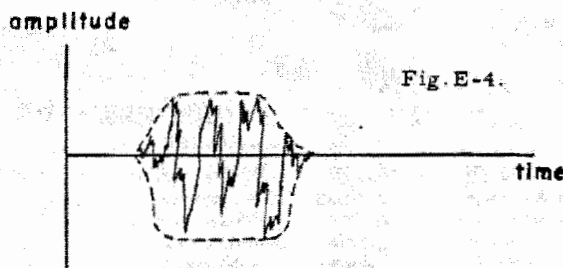
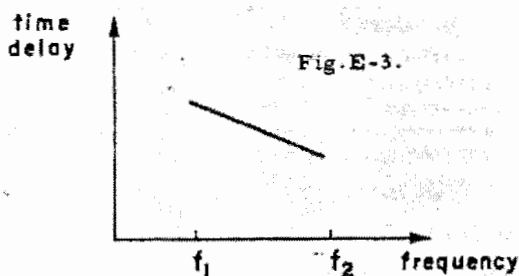
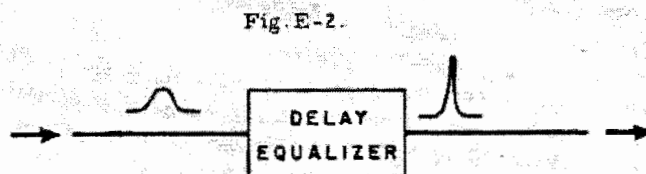
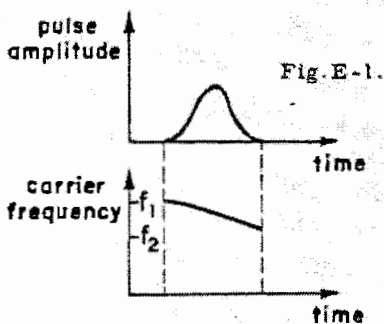

S. E. Miller

~~SECRET~~

~~CONFIDENTIAL~~

APPENDIX F

CATHODE-RAY TUBE RESOLUTION

~~CONFIDENTIAL~~

~~SECRET~~

~~SECRET~~

~~CONFIDENTIAL~~

APPENDIX F  
CATHODE-RAY TUBE RESOLUTION

During the course of the BEACON HILL briefings, it was indicated to us that the cathode-ray tubes in present-day standard radar sets do not have adequate resolution. We concur in this opinion. The present-day standard cathode-ray tubes display about one-half the available information when a 20-mile range sweep is used, and proportionally less of the available information with the longer-range sweeps. This wholly unsatisfactory situation is unnecessary, for the available art if properly employed will produce vastly improved cathode-ray tubes.

Two factors that influence the cathode-ray tube resolution are the size of the electron beam when it strikes the tube face and the characteristics of the phosphor used on the face of the tube. A quick-fix improvement for the present standard radars can be brought about by replacing the cathode-ray tubes with new ones that employ an improved phosphor. Through this approach, the resolution can be improved by a factor of about two - from 250 television lines to about 500 television lines. There is work under way within the Air Force (at WADC and Carswell AFB) and at the Bell Telephone Laboratories to make use of the new phosphors. This improvement is urgently needed and should be expedited by all possible means, in view of the fact that the resolution of present-day radars is the fundamental limit on the bombing accuracy that can be obtained.

For the long term, a large additional improvement can be realized. It is the considered opinion of electron-beam experts that a further improvement on the order of five to one, corresponding to 2500 television-line resolution, should be achievable. Such a tube might be employed with a straight-line scan as part of a recording mechanism in connection with the side-looking radar mentioned in Chapter 9, or, alternately, might be used in the normal PPI-type presentation. There are some practical difficulties to achieving this improvement, but the major research and development organizations in this field should be able to resolve them. Other difficulties might present themselves by virtue of aberrations due to mechanical irregularities in the electron gun or in the focusing coils, and these would need to be corrected before the finer spot could be attained. This might mean closer mechanical tolerances and some increased costs. Deflection defocusing, if not corrected, might seriously degrade the resolution at the edges of the screen, but it should be possible to compensate for this in the focusing circuits. The phosphor itself might have to be made finer, but this also could be done. Higher voltages would be required on the cathode-ray tube, but we are convinced that this represents more of an inconvenience than a real hazard or obstacle. In general, it is felt that this additional improvement can be obtained in a straightforward manner; but it will require a careful application of science throughout the cathode-ray tube and associated circuit design, rather than merely new assemblies of existing components. It may be noted that standard television tubes have a resolution in the range 500 to 1000 lines and that the proposed improved radar tube has a resolution about five times this.

In order for the human eye to take advantage of the 2500-line resolution, it is necessary that such a tube have a diameter of five inches or more.

As radars are improved, it certainly will be the trend to use shorter impulses

~~CONFIDENTIAL~~

a-53

~~SECRET~~

~~CONFIDENTIAL~~

~~SECRET~~

for better range resolution and sharper beams for improved azimuth resolution. In order to take advantage of these fundamental radar improvements, it is necessary to develop an improved cathode-ray tube. Furthermore, existing radars require nearly 2500-line resolution in order to display the available information on the 50-mile (or longer) range sweeps. It is recommended that a qualified contractor be given the job of building a cathode-ray tube with 2500-line resolution, and that the associated higher-voltage power supplies (and possibly pressurizing techniques) also be developed for Service use.

S. E. Miller

~~CONFIDENTIAL~~

a-54

~~SECRET~~



~~SECRET~~

~~CONFIDENTIAL~~

APPENDIX G

RADAR PREDICTIONS

~~CONFIDENTIAL~~

~~SECRET~~

~~SECRET~~  
~~CONFIDENTIAL~~

APPENDIX G  
RADAR PREDICTIONS

1. Existing State of the Art and Use of Copper Plates in Ultrasonic Trainers by SAC Units

The current practice at each SAC wing is to have its assigned targets carefully studied, predictions made according to methods now established, and a copper plate made for use in the ultrasonic trainer. Each radar observer then uses this plate in the trainer a certain number of times per month. It is of obvious value to have on the ground an aid that simulates the actual target as it is seen on the scope in flight, that stimulates interest in target study and that increases the ability of the radar observer to recognize definite and critical returns. The methods established for making predictions and the copper plates have served a useful purpose; but, since many uncertainties and problems still persist in this area, some members of the BEACON HILL Study Group attempted to investigate the matter in some detail. This review led to three conclusions:

- (a) although the ultrasonic trainer has many inherent limitations, the quality of predictions and plates could be improved;
- (b) some of the basic instructions laid down for making predictions and producing plates are contradictory to known facts and should be revised;
- (c) there should be recognition of the danger of implanting a fixed impression in the mind of the radar observer that his target will look very much like what he has repeatedly observed on the ultrasonic trainer.

Many competent radar observers have noted that even persistent returns tend to describe orbits, or to scintillate, on the scope, as can be demonstrated in various ways.\* This instability of even strong returns is due to several causes, among them the interrelationship of surfaces of buildings. This subject is injected here because in the current prediction practice each building is treated as though it existed without reference to other adjacent structures. It is commonly admitted that the angle of approach to a surface is of importance in the specular reflection, yet the current prediction system does not recognize any effect of street patterns. Irregular copper projections for the plate are made with a pin to include a large number of buildings built on a rectangular grid pattern. While American cities have rectangular grid street patterns, those of target cities are more irregular, like the old section of New Orleans.

One of the Air Force publications deals with a wide variety of roof structures of the U.S.S.R. Yet in the radar prediction instructions all roofs are ignored as though they

\*Some work has been done by the Display Unit at the Aircraft Radiation Laboratory at Wright Field under Mr. C. Colbert and Dr. C. Kober.

~~CONFIDENTIAL~~

~~SECRET~~

~~SECRET~~

~~CONFIDENTIAL~~

ultrasonic trainer, they will develop an indelible mental picture of what the target will look like on their actual bombing run. To draw a parallel to football, if a coach put his first team through repeated drills of one play only, and arranged his scrub team to react always in the same manner, the team would be inadequately trained to cope with an adversary equipped with a bag full of tricky plays. Instead of each radar operator practicing week after week on the same plate, it is urged that there be perhaps four or five plates made of each target city, instead of one. The radar operator would be told in advance that instead of seeing the familiar plate, there were four new ones. These new plates would try to anticipate how the target would appear if the city grew in various ways around the periphery of the static center. This would give a clue to how well the radar operator adjusts his identification of critical reference points. It would prepare him for possible changes to the left or right of course, for more "clutter" in front of the target, and for an over-all shape of the city which he may not have expected to see from 40 miles but which, because of its relation to other positively identifiable features, does prevent him from identifying his assigned "haystack". There may be some merit in occasionally placing in the ultrasonic trainer a "spoof" plate and in determining whether or not the radar operator recognizes it as such before he closes in too near to make an effective change of course. If some method like this (employing several copper plates), is not used, the radar operators are hardly to blame if they form a mental fixation as to how the target will appear on the scope on the bomb run. They then may try to reconcile what they see on the actual bomb run with what they remember on the trainer, rather than to relate what they see on the scope to the new scope photos that reconnaissance may provide for them.

(f) Some thought should be given to the problem that may face radar operators when they try to locate an aiming point in an area of bomb damage. The scope photos under these conditions may appear quite different from those shown by the radar reconnaissance, prior to the effects produced by earlier bombers on the same mission. We suggest that some light may be thrown upon the problem by an analysis of radar returns from rubble compared with returns from undamaged buildings. As an example, if scope photographs of German cities (such as Darmstadt) were taken before and after bombing with APS/15 by the Eighth Air Force in World War II, valuable clues might be provided for a study of this problem.

G. K. Geerlings

~~CONFIDENTIAL~~

a-60

~~SECRET~~

~~SECRET~~

~~CONFIDENTIAL~~

APPENDIX H

RADAR RECONNAISSANCE IN NORTHERN LATITUDES

~~CONFIDENTIAL~~

~~SECRET~~

~~SECRET~~  
~~CONFIDENTIAL~~

APPENDIX H  
RADAR RECONNAISSANCE IN NORTHERN LATITUDES

The following paragraphs describe a particular lack of knowledge by the USAF in one area, which may prove disastrous, yet the means of remedying the gap are already in being.

The routes that certain SAC units, bombers or reconnaissance, will take post D-Day, require accurate landfall. The characteristics of certain coastal areas will prove confusing even in the summer because of the serrated pattern. There are rendezvous points, control points, and other critical points to which aircraft will have to fly; yet these control points are in latitudes that may show considerable differences on the radar scope, depending upon the season of the year.

Last autumn, LIFE magazine printed some illustrations of possible ice landing fields in northern latitudes, consisting of both close-up visual oblique photos and radar-scope photos. The scope photos showed positive returns from the smooth part of the ice, this being confirmed by comparing radar-scope photos with visual oblique ones. This "inversion" (positive radar returns where negative ones are expected) has also been noted by the Alaskan Air Command, with rivers producing negative returns in the summer but positive returns in the winter.

Another problem is the outline of coastlines in very northerly latitudes. The Royal Canadian Air Force is said to have done considerable work in developing navigation skills in recognizing the location of the actual shore line, even though the entire area is under snow and ice from the landfall in question to the North Pole.

It is recommended that an effort be made to have all known data collected for immediate study, that the aid of the RCAF be enlisted to contribute what they already know, and that the RCAF be encouraged to dovetail their future flying in conjunction with the USAF so that the maximum information can be learned from the fewest possible flights.

If weather aircraft are or can be fitted with the APS-23 radar, it would add to needed information concerning variable radar returns due to seasonal changes. Most navigators are going to expect radar returns to bear the same relationship to their maps that they have experienced in more temperate latitudes. It would be ideal if the navigators could be briefed by being shown a series of visual photos (vertical or oblique) paired with radar-scope photos, taken in autumn after flooding, after freezing before any snow has fallen, after successive snows have piled up on the ice and drifted and smoothed abrupt banks, after melting and flooding have taken place, and finally after mid-summer with river beds reduced to only a trickle of water. To have maximum utility, such a series of photos should be taken on the same course, at the same altitude, with the same equipment, resulting in photos taken always from above the same series of points on the ground.

G. K. Geerlings

~~CONFIDENTIAL~~

~~SECRET~~

~~SECRET~~

~~CONFIDENTIAL~~

APPENDIX I

ACOUSTIC SENSING TECHNIQUES FOR INTELLIGENCE USE

~~CONFIDENTIAL~~

~~SECRET~~

~~SECRET~~  
~~CONFIDENTIAL~~

APPENDIX I  
ACOUSTIC SENSING TECHNIQUES FOR INTELLIGENCE USE

There is a recording technique commonly known as LOFAR in which acoustic waves are displayed on a chart that has time on one axis and frequency of radiation along the other axis, with the intensity of received acoustic radiation shown as an intensity variation on the chart. This system, which is peculiarly adapted for displaying radiations that are concentrated in one or several portions of the acoustic band, was originally developed in connection with the Bell Telephone Laboratories' work on visible speech. The technique is apparently very sensitive. For example, it may prove possible to detect the sound from a propeller-type airplane at a distance of about 10 or 20 miles using an acoustic receiver at a quiet ground-based location. As another example of the sensitivity of this type of equipment, it is said to be about 50 db more sensitive than the ear at 100 cycles. This is quite striking and means that a great many things that the human cannot hear will be detected by such equipment.

Exploratory work along this line is being carried out at the Bell Telephone Laboratories under the Office of Naval Research Contract known as PROJECT JEZEBEL.

It is quite apparent that airplanes are not suitable vehicles for an acoustic-sensing technique, due to the high level of ambient noise. A balloon is an ideal vehicle for carrying an acoustic-sensing set; but, unfortunately, at altitudes that are discussed for GOPHER (i.e., at altitudes of approximately 100,000 feet) the mean free path is on the order of the wavelength of a 1000-cycle acoustic wave. It is thus anticipated that rather large attenuations would be present, and it is somewhat doubtful whether sounds from the ground could be detected. At the present time, therefore, we do not see a way of applying the acoustic-sensing technique in airborne reconnaissance.

It is possible, however, that acoustic sensing may be of value from the intelligence standpoint for listening for aircraft at ground stations near the front lines, or for the detection and analysis of the shock waves that travel through the ground.

It is recommended that the results of PROJECT JEZEBEL be watched carefully and that continued thought be given to possible uses of acoustic sensing for intelligence-gathering purposes.

S. E. Miller

~~CONFIDENTIAL~~

~~SECRET~~