



ambient pressure diving

Closed Circuit Rebreathers

incorporating



Rebreather User Manual

INSPIRATION

EVOLUTION CE

EVOLUTION+

© 1997-2012 This manual remains the copyright of Ambient Pressure Diving Ltd and cannot be reproduced without prior written approval.

Author: Martin Parker

Revision: Nov 2012 (Incorporating Software Version 05.01.00/ including Recreational 1&2)

CONTENTS

REBREATHER LAYOUT:	8
MANUFACTURER:	9
EC TYPE APPROVAL:	9
EC PPE ARTICLE 11B APPROVAL:	9
QUALITY CONTROL:	9
APPLICABLE LAW:	9
WARRANTY EXCLUSION:	9
TRAINING REQUIREMENT:	10
REBREATHER FEATURES:	11
Dual oxygen controllers: Patent Nos. US6712071B1, EP1015077	11
Dual Head Up Fibre Optic Displays: Patent No. EP1580116A1	11
Intelligent Battery System:	11
Suppressible Warnings:	11
Wrist Mounted Display:	12
Setpoint Switching: Manual, Auto or Gradual	12
Backlight Control:	12
Demo Mode	12
Continuous Oxygen Control	12
Decompression Options:	12
Training Level Options:	12
Auto-Activation:	13
CO ₂ scrubber monitor and Temp-Stik – Patent Number: EP13163A1	13
Oxygen Cells with Co-axial Connector:	13
PC Download and Upload:	13
Language Options:	13
Dive Log:	13
Download Storage:	14
Projection Dive Planner:	14
At a distance diagnostics (via email):	14
At a distance diagnostics (via internet):	14
CLOSED CIRCUIT SURVIVAL	15
VISION EYE TEST	16
1.0 IMPORTANT INFORMATION	17
1.1 Gas	17
1.2 Weighting	17
1.3 Harness	18
1.4 Buoyancy Control	18
1.5 Familiarity of Controls and Harness	18
1.6 Understanding ppO ₂	19
1.7 Setpoint Selection	20
1.8 Pre-dive Checks	23
1.9 Descending	23
1.10 Mask Clearing and Pressure Equalisation	23
1.11 Mouthpiece	23
1.12 Ascending	23
1.13 Breathing Resistance	24
1.14 Counterlung Choice	24
1.15 Gas Consumption	25

1.16	System Integrity - Leaks	25
1.17	Check for Water	26
1.18	Flooding and Clearing Drills	26
1.19	Water Management	26
1.20	System Integrity - Indications	27
1.21	Batteries	27
1.22	Surface Swimming	28
1.23	Surface Buoyancy and Trim	28
1.24	Quick Post-Dive Checks	28
1.25	Practise	28
1.26	Solenoid Operation	29
1.27	Auto-Activation	30
1.28	Solenoid operation and the main oxygen risks during the dive	31
	OXYGEN DANGER POINTS	32
2.0	DEFINITIONS	33
3.0	OPERATIONAL CONSIDERATIONS	37
3.1	General	37
3.2	Gas Consumption	38
3.3	Oxygen Benefits	39
3.4	Decompression	40
3.5	Oxygen Controllers	40
3.5.1	Accuracy of the Oxygen Controller	40
3.5.2	Oxygen Cell Life	40
3.5.3	Interpreting the ppO ₂ Displays	40
3.5.4	Voting Logic	41
3.5.5	Effect of Moisture on the Cells	41
3.5.6	Setpoint Selection	42
3.5.7	Pulmonary Oxygen Toxicity	42
3.5.8	Oxygen Limits for Diving Operations	43
3.6	Duration of the CO ₂ Scrubber	43
3.6.1	Duration of the “Inspiration” and “Evolution+” 3 Hour CO ₂ Scrubber	43
3.6.2	Duration of the “Evolution” 2 Hour CO ₂ Scrubber	44
3.6.3	How do I know when the CO ₂ absorbent can no longer absorb CO ₂ ?	44
3.6.4	Extra CO ₂ Considerations	45
3.7	Symptoms Associated with Low and High Oxygen Levels, High CO ₂ Levels and Oxygen Toxicity	46
4.0	APPARATUS COMPONENTS	47
4.1	Inspiration Vision, Evolution and Evolution+ Schematic	47
4.2	Counterlungs	47
4.3	Over-Pressure Exhaust Valve	48
4.4	Mouthpiece Valve	48
4.5	Breathing Hose Connectors	49
4.6	Colour Coding of Convolute Hose Connections	50
4.7	Diluent and Oxygen Inflators	50
4.8	Automatic Diluent Valve (ADV)	51
4.9	Weight Pockets	52
4.10	Buoyancy Compensator and Harness	52
4.11	Auto Air	52
4.12	Audible Warning Device	53
4.13	Oxygen Solenoid	53
4.14	Head Up Displays	53
4.15	Scrubber Monitor (optional)	53
4.15.1	Scrubber monitor Display	54
4.15.2	Subsequent dives	55

4.15.3	Tracking.....	55
4.16	Case Mounted Cylinder Clamp (optional)	55
4.17	Display strap.....	55
5.0	POWER ON.....	56
5.1	General	56
5.2	Switch On.....	57
5.3	Software (Code) Version.....	58
5.4	Owner's Registration Screen.....	58
5.5	Electronics Self-Test	58
5.6	Temp-Stick Test	58
5.7	Failed Solenoid or Oxygen Cell Self-Test	59
5.8	Battery Test	60
5.9	Open O ₂ Valve.....	61
5.10	Open Diluent	62
5.11	Check Bailout.....	62
5.12	Check Counterlung Pressure Relief Valve.....	62
5.13	Check Mouthpiece Mushroom Valves	62
5.14	Elapsed On Time	62
6.0	CALIBRATION.....	63
6.1	Must Calibrate!.....	63
6.2	Calibrate?.....	63
6.3	Ambient Pressure	63
6.4	Oxygen %	64
6.5	Open Mouthpiece	64
6.6	Unsuccessful Calibration.....	65
6.7	Successful Flush.....	65
6.7.1	Verification of ppO ₂	66
6.7.2	Indicators to look for during calibration.....	66
6.7.3	Checks prior to each use.....	66
6.7.4	Periodic Calibration Check	67
6.7.5	Linearity Check	67
6.7.6	Verifying the ppO ₂ during the dive	68
7.0	DIVE MODE.....	69
7.1	Dive Mode – Surface Display	69
7.2	Master/Slave Controllers.....	70
7.3	Master/Slave Batteries.....	70
7.4	ppO ₂ display	71
7.5	Dive Mode – Underwater Display.....	71
7.6	Switch Functions – Dive Mode	72
7.7	High/Low Setpoint Switching	73
7.8	Head Up Displays (Hud) – Dive Mode	74
8.0	MENU MODES	76
8.1	Menu Mode – surface –CCR.....	76
8.1.1	High Setpoint Adjustment.....	76
8.1.2	Low Setpoint Adjustment.....	77
8.1.3	Setpoint Switch on descent.....	77
8.1.4	Setpoint Switch on ascent.....	77
8.1.5	HUD Intensity	78
8.1.6	LCD Contrast	78
8.1.7	Backlight Options.....	78
8.1.8	Backlight Brightness	79
8.1.9	Elapsed On Time - Display and Reset.....	79
8.2	Menu Mode – surface -DECO.....	79

8.2.1	Select Diluent.....	80
8.2.2	Gradient Factors (Trimix version only)	81
8.2.3	Conservatism Level (Nitrox version only)	82
8.2.4	Depth Units	82
8.2.5	Time and setting.....	82
8.2.6	Dive Log	83
8.2.7	Oxygen Exposure %	84
8.2.8	Demo Mode	84
8.2.9	Demo Mode – “ Underwater”- Menu	85
8.2.10	Demo Mode – Surface Interval Display	86
8.2.11	Exit Menu.....	86
8.3	Menu Mode - Underwater.....	86
8.3.1	Open Circuit Decompression (Not available in Dive Timer version)	87
8.3.2	Change Diluent	89
8.3.3	Cell Check.....	90
8.3.4	Additional Underwater Menu Displays/Options - CCR	90
9.0	WARNINGS AND REMEDIES	92
9.1	Pressure Sensor Warning	92
9.2	Low Oxygen Warning.....	92
9.3	High Oxygen Warning	93
9.4	Open Circuit Oxygen Warnings.....	94
9.5	Cell warning	94
9.6	Low Battery Warning	95
9.7	Dive Start Error!	96
9.8	CO ₂ Scrubber Warning!	96
9.9	Oxygen Toxicity Warnings.....	97
9.10	Ascent Speed Warning.....	97
9.11	Ceiling Violation (decompression versions only).....	97
9.12	Slave Oxygen Controller Promotion to Master	98
9.14	Error Priority.....	98
10.0	POWER CONTROL.....	99
10.1	Power Shutdown	99
10.2	Promoting Slave Controller to Master	100
10.3	Reinstating a switched off Slave Controller	100
11.0	DECOMPRESSION	101
11.1	Gas Selection	101
11.2	Gradient Factors (Trimix) and Conservatism Settings (Nitrox)	102
11.3	Deep Stops	103
11.4	Pre-dive - Surface	103
11.5	Submerging.....	104
11.6	Diluent Selection.....	104
11.7	Dive Timer	104
11.8	No Stop Time.....	104
11.9	TTS – Total Time to Surface	104
11.10	Ceiling.....	105
11.11	Ceiling Violation.....	105
11.12	Estimated Decompression.....	105
11.13	Fast Ascent.....	105
11.14	Surface Interval Display	106
11.15	Missed Deco !	106
12.0	PC CONNECTION.....	107
12.1	Standard equipment	107
12.2	Terminology.....	107

12.3	Software.....	107
12.4	Hardware:	107
12.5	File Formats.....	108
12.6	Step by Step Guide to Software and Hardware Installation.....	108
13.0	MAINTENANCE.....	113
13.1	CO ₂ Absorbent Replacement.....	113
13.2	Gas Cylinders	121
13.3	First Stages	121
13.4	LP Oxygen Hose	122
13.5	Post-Dive Maintenance	122
13.5.1	Cleaning and Disinfecting the Unit.....	122
13.5.2	BUDDY Clean Disinfectant.....	122
13.5.3	Lubrication	122
13.5.4	Washing and Disinfecting the Breathing Circuit	123
13.5.5	Oxygen Sensors.....	124
13.5.6	Exchanging Oxygen Sensors.....	124
13.6	Storage.....	126
13.7	Precautions when using High Pressure Oxygen.....	127
13.8	Service Intervals.....	127
14.0	EMERGENCY PROCEDURES	128
14.1	Bail-Out (Emergency Breathing)	128
14.2	Emergency Procedures	128
14.3	Diluent Flush	129
14.4	Emergency Rescue of an Unconscious Rebreather Diver.....	129
14.5	Flooded Loop	129
14.6	Manual Control of ppO ₂	130
14.6.1	Manual addition of O ₂ and O ₂ flush method	130
14.6.2	Manual addition of diluent	130
14.6.3	Using the Inspiration, Evolution or Evolution+ as a pure oxygen rebreather.....	130
15.0	BRIEFING OPEN CIRCUIT DIVE PARTNERS	131
15.1	The Rebreather Diver – What to Expect, What to Do.....	131
15.2	Classic Problems, Causes and Resolutions	132
16.0	WARRANTY.....	133
17.0	IMPORTANT CAUTIONARY NOTES	134
18.0	TECHNICAL DATA	135
19.0	DANGERS INTRODUCED BY USER MODIFICATIONS.....	139
20.0	DIVING DEATHS	140
	APPENDIX 1 SURFACE MENUS	141
	RECREATIONAL 1	141
	RECREATIONAL 2.....	142
	DIVE TIMER.....	143
	NITROX	144
	TRIMIX	145
APPENDIX 2	Determining The Oxygen Purity (When The Gas Quality Is Not Certified)	146
APPENDIX 3	Self Check Questions and Answers.....	147
APPENDIX 4	Decompression Tables	149
APPENDIX 5	Buddy Clean Data Sheet.....	151
APPENDIX 6	Sofnolime Transportation Declaration	153

APPENDIX 7	Sofnolime ® data sheet.....	155
APPENDIX 8	Trimix in the Rebreather.....	158
APPENDIX 9	Export License Requirements.....	159
APPENDIX 10	RoHS and Weee Compliance.....	160
APPENDIX 11	Check Lists.....	161
	Pre Dive /Assembly Check List	161
	Pre-Breathe Sequence.....	162
	In-Water Checks and Important Procedures.....	162
	Post-dive actions.....	163

REBREATHER LAYOUT:

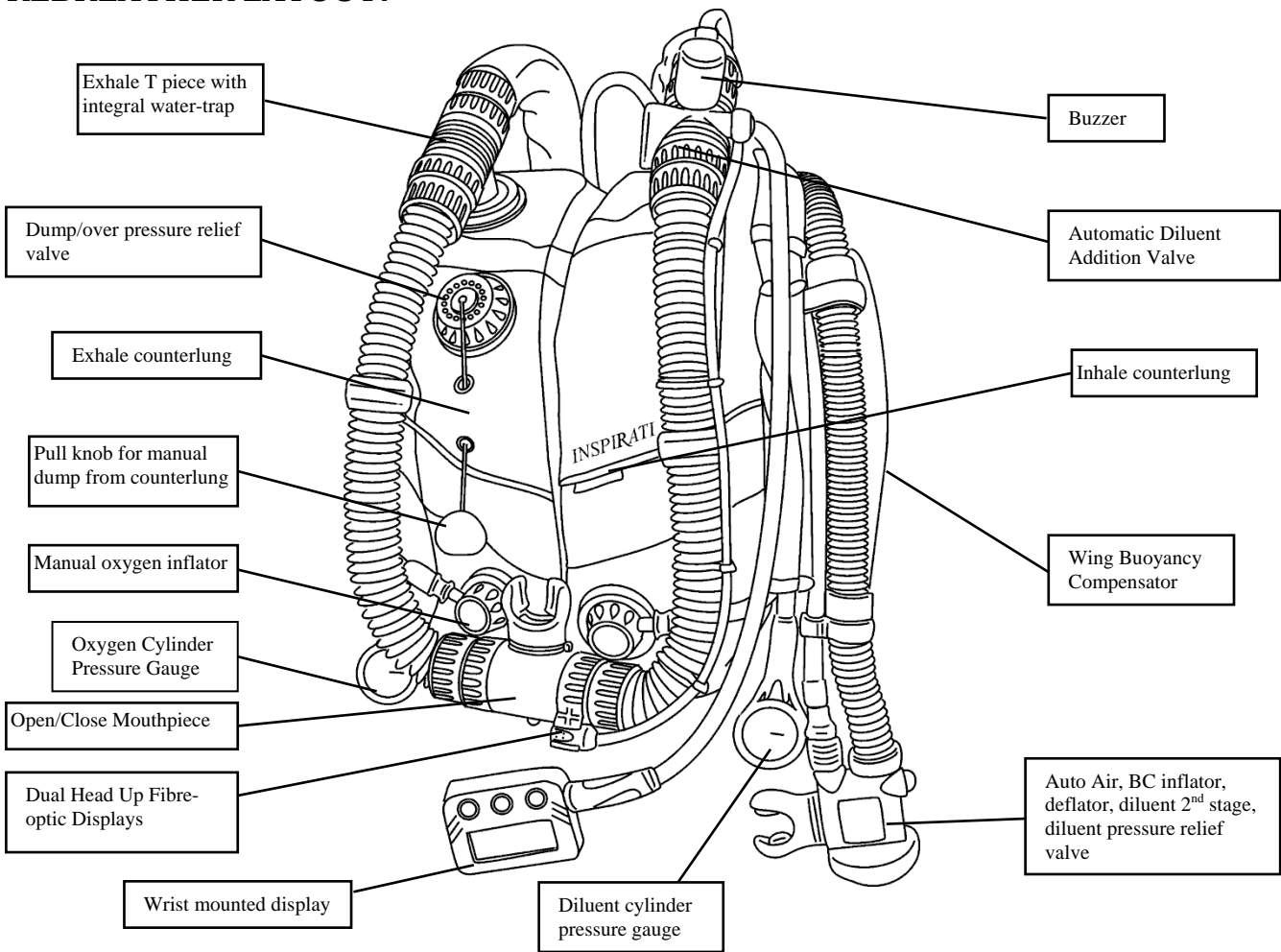

Optional Rear Mounted Counterlungs:

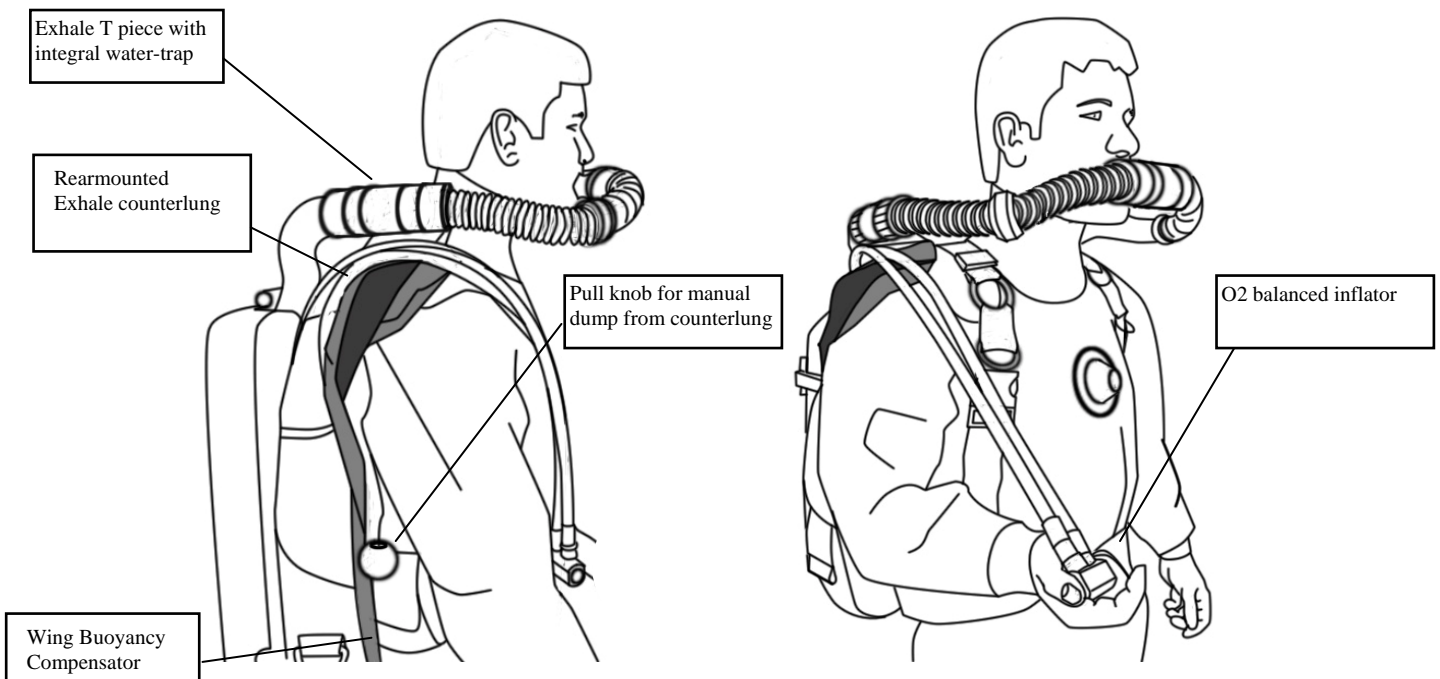

MANUFACTURER:

Manufactured in the UK by Ambient Pressure Diving Ltd , Unit 2C, Water-ma-Trout Industrial Estate, Helston, Cornwall TR13 0LW. Telephone: +44(0)1326 563834. Fax: +44(0)1326 573605

EC TYPE APPROVAL:

EC Type approved by SGS United Kingdom Ltd, Unit 202b, Worle Parkway, Western-Super-Mare, Somerset, BA22 6WA. Notified Body number 0120. Assisted by DERA (Defence Equipment Research Agency, now QinetiQ), Alverstoke and ANSTI Test Systems, Hants.

The “Inspiration”, “Evolution” and “Evolution+” are CE approved to 40m using an air diluent and 100m using a Heliox or Trimix (with a max. END of 30m at 70m, reducing to an END of 24m at 100m). The EC Type Approval was granted on the APD Manufacturer’s Technical Specification and satisfactory user trials. The Technical Specification was based on the “Respiratory equipment-Self-contained re-breathing diving apparatus” standard EN14143:2003 excluding clauses 5.6.1.3 (peak respiratory pressures at higher breathing rates) and 5.8.8.(hose elongation test). It was considered that the products met the Basic Health and Safety Requirements (Annex II) of the PPE Directive 89/686/EEC.

EC PPE ARTICLE 11B APPROVAL:

The on-going certification to allow CE marking under Article 11B of the PPE Directive 89/686/EEC is granted by Lloyd's Register Quality Assurance Ltd. CE0088.

QUALITY CONTROL:

All Ambient Pressure Diving Products are designed and manufactured under the ISO 9000 Quality Control System and is audited at regular intervals by Lloyd’s Register Quality Assurance Ltd. Scope: Design, Manufacture and servicing compressed gas diving apparatus, closed circuit underwater breathing apparatus and associated equipment including equipment in support of MOD contracts. Management of the design, development and lifecycle support of associated safety critical hardware and software.

APPLICABLE LAW:

All products are sold only on the understanding that only English Law applies in any and all legal claims against the manufacturer, regardless of where the equipment is purchased or where used. Should a claim be made the venue for this claim and subsequent action will be Truro, England.

USA exception: All products are sold into the USA and to US Citizens and domiciles only on the understanding that only North Carolina Law applies in any and all legal claims against the manufacturer, regardless of where the equipment is purchased or where used. Should a claim be made the venue for this claim and subsequent action will be Raleigh, North Carolina.

WARRANTY EXCLUSION:

It is dangerous for untrained and uncertified persons to use rebreathers. Therefore, use of this equipment by an uncertified person renders any and all warranties null and void.

TRAINING REQUIREMENT:



WARNING

Life support equipment, which includes rebreathers, requires specialist training before use.

Rebreathers are only sold from the factory when evidence is provided of suitable training having been completed or evidence is provided that training is to be completed with a factory recognised specialist rebreather instructor.

Several problems may arise when using a rebreather, many of which, if not dealt with properly, may have fatal consequences. It is, therefore, essential that you understand exactly how this rebreather works, the maintenance that must be carried out, the purpose of every component and the operational requirements. This manual is not the definitive guide to rebreather diving and is no substitute for proper training and closed circuit rebreather experience.

Do not use the rebreather without proper training.

Build up your experience gradually. Do not expect to be a good rebreather diver straight away. It takes time and practise to perfect buoyancy control and to become aware of the idiosyncrasies of rebreather diving and of the apparatus.

Most of the problems you can experience are referred to in this instruction manual. It is in your interest that you take the time to read and study it.

All products are sold only on the understanding that only English Law applies in cases of warranty claims and product liability, regardless of where the equipment is purchased or where used. USA exception: North Carolina law applies and the venue shall be Raleigh, NC.

REBREATHER FEATURES:

Ambient Pressure Diving (APD) Rebreathers using VISION electronics utilise the same oxygen control program as the CLASSIC Inspiration – an oxygen controller which set new standards for Sport and Military rebreathers in terms of holding and maintaining the ppO_2 close to the target pressure (setpoint) in all phases of the dive. The VISION electronics hardware though is quite different to that of the Classic Inspiration.

Dual oxygen controllers: Patent Nos. US6712071B1, EP1015077.

There are two independent oxygen controllers, C1 and C2, located next to each other in the lid of the scrubber, permanently encapsulated for water and vibration proofing. Once switched on and calibrated these controllers separately measure the voltages from the oxygen cells. C1 will be the Master controller if it is connected to the battery, oxygen cells and solenoid. The Slave controller, normally C2, constantly monitors the Master and automatically promotes itself to Master should C1 fail to notify the Slave of its existence. The Slave can be promoted to Master at any time by the diver if desired. The operation of the rebreather is separately monitored by the Slave controller and warnings are independently generated when appropriate.

Dual Head Up Fibre Optic Displays: Patent No. EP1580116A1

Connected directly and separately to each oxygen controller is a pair of LEDs. One green and one red, mounted in the Head Up Displays (HUD) one above the other – four lights in total. The light from the diodes is transmitted to the diver's field of vision through plastic fibre optic cables. The fibre optic cables are an elegant solution requiring no water or pressure proofing, are durable, flexible and are both easy and cheap to replace when necessary. Under normal dive conditions the diver will see two green lights next to each other, one for each oxygen controller. The LEDs work down to low voltages, so even after the wrist display has faded and the solenoid has stopped firing the LEDs continue to provide data on the status of the oxygen pressure, allowing the diver to effect an egress with manual gas addition. The brightness of the LEDs can be changed in the menu to reflect the ambient light conditions. You may need it bright in sunlight or dimmer at night.

Intelligent Battery System:

There are two battery compartments, B1 and B2. B1 is the battery compartment for oxygen controller C1; B2 is the battery compartment for C2. If there are no batteries in the B1 compartment, there will be no C1 controller, the same applies for B2 & C2 – no batteries, no controller. If there are batteries in the B1 slot that have sufficient power for all operations it will automatically be the Master battery. If they only have sufficient power to start the C1 processor, C1 will still be the Master oxygen controller but B2 will be promoted to the Master battery status and will be used for powering the solenoid and wrist display. During use, the same thing happens, B2 will be promoted to Master should B1 reach the low battery warning level. Once B2 also reaches the low battery warning the power will be drawn from both B1 and B2. Each change will be notified to the diver via the HUD and wrist display as well as the buzzer. The diver cannot change which batteries are providing the power to the main power consumers (solenoid and handset) without physically swapping batteries in their slots prior to diving and in the event that one of the batteries is below the low battery warning level, the power will always be drawn from the batteries with sufficient voltage regardless of which slot it has been inserted into.

Suppressible Warnings:

Some warnings are not suppressible; the cause of the warning has to be addressed to stop the alarm. For instance High and Low oxygen warnings are not suppressible; the ppO_2 has to be brought within the range 0.4 to 1.6 bar to quiet these HIGH priority warnings. Similarly the Decompression Ceiling and the last level CO_2 Scrubber warnings (if Temp-Stik fitted) are not suppressible.

All other warnings can be suppressed for 5 mins by pressing and holding the right switch for 2 secs. The warning continues to be displayed on the handset but the HUD and buzzer return to normal dive operation.

Wrist Mounted Display:

On the surface the wrist mounted display shows which oxygen controller, C1 or C2, is controlling the ppO₂; the setpoint, the scrubber status (if chosen), the levels of both batteries (and which one is providing the power for the solenoid and wrist display); the ppO₂ from all three oxygen cells in real time as measured by the Master controller; the Slave's ppO₂ displays on request. On the surface, the date and time are shown with atmospheric pressure. Underwater the dive time and depth are shown along with maximum depth. If either the Nitrox or Trimix decompression options are purchased the display also shows No Stop Time, which reverts to Total Time to Surface (TTS) and deco-ceiling once the diver requires decompression stops. The screen features an easily replaced, peel off, self-adhesive, screen protector.

Setpoint Switching: Manual, Auto or Gradual

On a Closed Circuit Rebreather it is necessary to use different setpoints during different phases of the dive. It is typical to use a low setpoint on the surface and when shallow and for descent to approx. 25m and then a high setpoint for the deeper descent, bottom portion of the dive and for the ascent changing again to the low setpoint for the ascent from the last decompression stop. The Vision electronics allows three different ways of changing setpoint: Manual, Auto or Gradual. Auto allows the diver to change from Low to High at a pre-programmed depth but also retains the diver's ability to manually change between High and Low setpoints at any time. On the ascent, the unit will change to the low setpoint at the pre-programmed depth. Alternatively, the Gradual method can be chosen where the setpoint will increase automatically in 0.1bar increments during the descent and will decrease automatically during the ascent.

Backlight Control:

The backlight may be switched on for the duration of the dive, it can be switched off or the diver may elect to have it come on when a switch is pressed. The brightness of the backlight may be dimmed to save power consumption. The backlight setting may be changed underwater if desired.

Demo Mode

The display may be taken into a simulated underwater dive mode to see depth, time, scrubber monitor, oxygen toxicity loadings and decompression information. Dive Mode is an excellent way to practise the use of the underwater menus.

Continuous Oxygen Control

As soon as the unit is switched on ppO₂ control is taking place. Even before the display is taken into dive mode, the rebreather will try to maintain a setpoint of 0.21 bar. Obviously, if the diver fails to open the oxygen cylinder valve and continues to breathe from the unit the rebreather cannot maintain the ppO₂ despite it's best efforts. Once the ppO₂ falls to 0.16 bar the low oxygen alarms will be activated. Should the diver enter the water before completing the pre-dive sequence, once below 1.2m (4ft) the rebreather program goes into underwater dive mode with the low setpoint active. It will show steady red lights and display "Start Error!" – this may then be suppressed.

Decompression Options:

Nitrox and Trimix decompression options are programmed with the use of Unit specific System Keys, available from the factory. The decompression software is Bühlmann with the ability to change the conservatism levels. In the Trimix version the user can change the High and Low Gradient Factors to suit their own preference.

Training Level Options:

Training agencies are introducing new "Recreational" rebreather courses for teaching divers how to use "Recreational" type rebreathers within restricted envelopes. To compliment these "starter" courses two additional types of code have been introduced: Recreational 1 and 2. For use with this type of course certain hardware features are mandatory: e.g. Open Circuit Bailout Mouthpiece, Temp-Stik, Auto- activation and Clam seal scrubber cartridge assembly. The product is easily upgraded with the use of System Keys to Nitrox and Trimix when appropriate training is undertaken.

Auto-Activation:

To complement the new Recreational rebreather courses, auto-activation has been introduced as a hardware feature.

CO₂ scrubber monitor and Temp-Stik – Patent Number: EP13163A1

Located down the centre of the scrubber is an array of temperature sensors. As the CO₂ laden exhaled breath passes through the scrubber the temperature of each section is compared with the other sensors and the bar-display on the wristset is updated to show the hot sections of the scrubber (warnings are given if this area is too small for the diver's current depth) and by this means the exothermic reaction of the Sofnolime is tracked through the bed.

The APD Scrubber Monitor performs reliably and consistently in cold as well as warm water, it copes with ascents and descents, and even works with part-used Sofnolime, giving warnings at appropriate times on the HUDs and buzzer.

Oxygen Cells with Co-axial Connector:

The push-on, pull off gold-plated connectors allow easier cell removal and offer a more robust connection compared to conventional oxygen cells. The four-pronged base on the male connector offers a very secure anchor to the oxygen cell's PCB, improving reliability. The female connector made of gold-plated brass is much sturdier and capable of withstanding rough handling than the conventional oxygen cells. The blue moulded over-boot is designed to allow pressure balancing of the back of the O₂ cell and yet allow the cell to withstand a temporary submersion should the lid be flooded. The Teflon front face dispels moisture, it also allows very rapid gas transfer and cell reaction to changes in ppO₂. This allows the oxygen controllers to maintain the ppO₂ in real time as opposed to a pre-programmed sequence, eliminating the need for manual override during fast ascents or during periods of high work rate. The cell's location in the lid of the scrubber is the same as the Classic electronics, on the outlet tube, reflecting the ppO₂ of the mixed gas going to the inhale counterlung. In tests conducted at ANSTI and the Royal Navy's test house, QinetiQ, the accuracy of the sensors and oxygen controllers are measured against fast response analysers and mass spectrometers, which in turn are calibrated and referenced back to the National Physics Laboratory, proving the accuracy of the ppO₂ control for extended periods in arduous conditions.

PC Download and Upload:

Using the APD Communicator Software and Interface Bridge hardware, dive data may be downloaded from the rebreather electronics to a PC. The Interface Bridge is provided with every rebreather with both a serial lead and a Serial/USB adaptor lead for those users that do not have a serial port on their PC.

Program updates, Decompression option (Dive Timer, Nitrox, Trimix) release codes, language files and User registration screen updates may be downloaded over the internet and uploaded to the rebreather electronics via the same interface. Additionally, the real time clock can be synchronised to your PC time.

Language Options:

The electronics wrist mounted display is available in a range of languages: English, German, Dutch, Italian, Spanish, French, Portuguese, Czechoslovakian, Russian, Swedish and Danish. The language option is available at any time by simply loading the relevant language file from the website: www.apdiving.com/downloads/software/. This may then be uploaded to the electronics using the APD Communicator to convert the display text to the required language.

Dive Log:

The APD LogViewer program is supplied with each rebreather. A running total of "switched on" time and "dive time" is continuously appended. The LogViewer's front screen shows the dive profile and the ppO₂ display is shown continuously. Each file has a page for the dive detail (location, weather etc).

Download Storage:

A special USB stick, the APD DiveStore, has been developed which has a Fischer connector, allowing you to plug it into the rebreather lid and download all your dive files (and your friends' dive files) onto the USB stick. When home, you can connect the DiveStore into a USB port on your PC and process those dive downloads into individual dive files. (Please note: it is not suitable for connecting the rebreather to a PC, you would use the Bridge interface for that purpose).

Projection Dive Planner:

The Projection Dive Planner is provided with the APD DiveStore which doubles as the software security "dongle". This allows pre-dive CC and OC planning and experimentation with various decompression options for open water as well as "no clear surface" environments. At any time during the planned dive the bailout option can be selected and the quickest decompression using the best gases or the gases from your pre-constructed list will be calculated, taking into account the overhead environment. Any sector of the dive can be specified as an overhead environment, so you can plan a dive to 80m, and then plan a 20 minute swim into a tunnel and then have the planner calculate your decompression and bailout gas required taking into account the fact that you have a 20 minute horizontal swim before you can start the ascent. The tunnel doesn't have to be horizontal, you can add as much variation to the dive as you like. You can specify different gradient factors, ascent rates as well as max. ppO₂ and other variables for the bailout. All bailout gas quantities are calculated even advising you what size cylinder shall be carried taking into consideration your chosen gas reserve and fill pressure. A dive plan can be created involving multiple dives with a different surface interval for each to show you the effect of e.g. a week of diving. Additionally, the Table Generator is extremely powerful allowing you to quickly create bespoke decompression tables, sorted on depth or on dive time, both in ascending or descending sequence.

At a distance diagnostics (via email):

A "*.ccx" file is stored from each download from the electronics. The latest one may be requested by the factory from time to time for diagnostic purposes, for instance to help you determine why a particular warning occurred and to determine the most appropriate course of action. The unit's supply and service history is recorded within the file to give us an instant picture to speed up processing of service items.

User's personal details on the start-up screen such as name and phone number can be updated by the factory issuing a user specific file which you can upload to the Vision lid.

At a distance diagnostics (via internet):

Providing your PC is connected to the internet and your Vision lid is connected to your PC, using the APD Communicator we can interrogate your lid by remote access and see all the information as if the lid was sitting next to us in the factory. We can change user information, download dives or upload new code or system keys and run diagnostic checks wherever you are located in the World.

CLOSED CIRCUIT SURVIVAL

Rule No. 1: Know your ppO_2 at all times. - This cannot be over emphasised.

When you dive closed circuit you need to change the way you think: Diving with conventional or open circuit equipment you need to know: “Will I have something to breathe?”. But when diving with closed circuit equipment you need to know: “**What am I breathing?**”. **Never** breathe from any rebreather without knowing **what** you are breathing.



WARNING! If you fail to watch your ppO_2 and understand the implications - you will die, it is only a question of where and when.

The primary warning device for the ppO_2 is the wrist display. The Head Up Displays are Secondary warning devices.

The audible warning device is purely an additional safety aid and warns of excessive changes in ppO_2 only.

All divers, not just those with a hearing impediment, must watch the displays and never rely on just the audible warning.

If you are unable or unwilling to monitor your ppO_2 displays regularly then you must not use a rebreather.

Attitude keeps you alive: Normally, closed circuit rebreathers are used by experienced open-circuit divers. This can bring a level of over-confidence which can lead to serious problems. You are a novice again, please accept that and build your rebreather experience gradually.



WARNING! Historically APD rebreathers do not have automatic activation when you enter the water, however to comply with training agency requirements for “Recreational” type rebreathers an automatic activation is provided which switches the unit on when wet. Take care, if there are no batteries, or some other fault exists, there will be no switch on, so it is still necessary to switch the rebreather on prior to entering the water and to recheck it’s on before jumping in. **YOU** have to open the gas cylinder valves!

USE A CHECKLIST to make sure you have set your rebreather up properly and to be sure it is ready to dive. It’s not cool to be the first one in the water only to find you have skipped most of your checks.

IF IN DOUBT, BAIL OUT

VISION EYE TEST

Your eye-sight must be checked before using a rebreather, wearing your normal dive mask.

MUST BE READ LESS THAN 16 INCHES (40cm) FROM EYES

<p>INSPIRATION Confirm 69 hrs ELAPSED TIME DIVE NOW? CALIBRATE Yes No Confirm OPEN O2 VALVE CHECK DILUENT LOW OXYGEN MASTER 0.70 0.21 0.19 0.20</p> <p>HDIM7AN ETWO APQBC DIUWNM J BX XJKZ XKA7JSNXC SNCC NSCHKC CHSJ55 DC FHSD UFAHAA LNBZNCZC SDHC XBCBC SDHCA SDN9CMC A1JC NSDCM PWI Z3NCMVC</p>

SECTION 1

1.0 IMPORTANT INFORMATION

This Section describes some of the problems you may encounter in the early stages of using the Rebreather.



READ THIS SECTION BEFORE ENTERING THE WATER!

1.1 Gas

There are two cylinders on board. One contains oxygen and the other a diluent or dilutant. Normally, the oxygen is fed into the breathing circuit via a solenoid operated oxygen valve; the diluent is fed in manually. The oxygen is added to replace metabolised oxygen and to maintain the oxygen pressure during ascents and is an automatic process; the diver simply has to monitor it. The purpose of the diluent is to dilute the oxygen concentration to enable us to safely breathe the mixture in the breathing circuit (or loop) below 6m and also maintain the counterlung volume during the descent. Once at your target depth the diluent is no longer used unless you lose loop volume by accidentally exhaling through your nose, or you descend again. This low usage of diluent leaves a useful reserve of gas for BC inflation, suit inflation, oxygen cell checks and OC (open circuit) bailout.

The correct type of diluent is essential. Ideally, it should be breathable throughout the entire dive. So, at the start, use normal diving quality breathing air in the diluent cylinder. This is suitable for all depths down to your air diving limit (35 to 50m). Using a setpoint of 1.3, 50m is the maximum depth with an air diluent. Below 40m Heliox or Trimix (with a max. END of 30m at 70m, reducing to an END of 24m at 100m) is strongly recommended. Below 50m, Heliox or Trimix is essential. But, let's not consider diving deep with it just yet though. Let's get the basics right first. Build up your Closed Circuit experience gradually.



NEVER, NEVER use pure gases in the diluent cylinder such as pure Helium or pure Nitrogen - when something as simple as a manual diluent flush could and most likely will render you unconscious. The diluent **MUST** always contain a sufficient oxygen percentage to sustain life.



When using a diluent with an oxygen percentage lower than 21% do not breathe the diluent open circuit when in the shallows. Also, take extreme care if adding low oxygen percentage diluent to the rebreather when shallow. If the oxygen controller is inoperative, for instance if it's not switched on, the O₂ is turned off or the O₂ cylinder is empty then you will go unconscious. Consider changing your configuration and diving practise to eliminate this possibility.

1.2 Weighting

How much lead is required? As you become more experienced you will find that you only need to carry the same weight as you do when you dive with a single 15 litre cylinder. You may find it more comfortable to move 2-3 kg from your weight belt and put it in the weight pocket on the top of the unit. This aids in-water trim helping to keep you horizontal. During your first dives you may experience problems descending, so insert 2-3 kg in the weight pocket in addition to your normal weight belt. Using the counterlungs at minimum volume, i.e. just enough gas to take one full breath, brings many advantages including a minimum lead requirement, a better swimming position with reduced back strain and early warning of gas usage from the loop. If back pain is experienced then consider moving weight from the weight belt to weight pockets on the unit.

1.3 Harness

Having the correct size counterlung and harness is essential. Please seek help from the factory if you think you have the incorrect size. Too small is uncomfortable, too big is dangerous.

If the rebreather has a tendency to ride up, you have to do something about it. The counterlungs **MUST** sit down on your shoulders, to achieve this:

- 1) Loosen the shoulder straps, allow the unit to slide down your back then tighten up the waist strap. Use the integral weight pockets and crotch straps. By doing this the counterlungs are kept in the right place, on your shoulders and not too far forward, this improves the swimming position and eliminates back ache. **Do not** over tighten the shoulder straps; this pulls the rebreather up high and moves the T- pieces close to your head making it uncomfortable and the front convoluted hoses too long.
- 2) Dive with just enough gas in the counterlungs so you can take full, deep, breaths without the counterlungs bottoming out. To find this you have to vent from the loop until you meet inhale resistance, then either add gas manually a little at a time or rely on the ADV replacing the breathing volume. Diving with more gas in the loop will make the rebreather too buoyant and adversely affect trim.

1.4 Buoyancy Control

Buoyancy control will be different from open circuit and, whilst not being difficult, it does require some thought. When you breathe from a rebreather your buoyancy does not change. Consequently the dry suit or BC must be used for buoyancy control, as minor adjustments cannot be made by inhaling or exhaling.

If a dry suit is worn then we recommend using only the dry suit for buoyancy control and we recommend fitting a variable exhaust valve so this can be set for automatic venting during the ascent. These are particularly good when used on membrane dry suits. If operating at a constant depth, buoyancy control is much easier than open circuit, but the problems start when you conduct “saw-tooth” profiles. With any obstruction in your path you should now consider swimming around it, rather than over it. To go over the obstruction will almost certainly require venting of gas during ascent and inflation on return to the original depth.

1.5 Familiarity of Controls and Harness

The harness is available in 5 sizes. It is important to have the correct size. If you need advice, contact the factory.

Adjust all the straps to fit you prior to reaching the dive site. Ensure the inflator hose from your dry suit, connected to the LP port of the diluent cylinder’s first stage, has a long enough hose to reach your dry suit inflator.

Practise locating and operating all the rebreather and BC controls including:

1. Opening and closing the mouthpiece
2. Opening and closing the oxygen cylinder valve
3. Opening and closing the diluent cylinder valve
4. Operating the diluent inflator
5. Operating the oxygen inflator
6. Operating the variable exhaust valve (use the high pressure setting (rotate clockwise fully) when testing for leaks and use the low pressure setting (rotate anticlockwise fully) during the dive)
7. Operating the BC’s inflator and exhaust valves
8. Locating and using the emergency open circuit regulators (both diluent and oxygen)
9. Switching from low to high setpoint on the oxygen controller
10. Ensure the counterlungs will be held down on your shoulders and will not float up when in the water. Failure to do so will result in greater breathing resistance and may cause the pressure relief valve to vent when on the “Dive” pressure setting
11. Ensure you can see the head up displays

1.6 Understanding ppO₂

The ppO₂, or oxygen pressure, in the breathing circuit is what keeps you alive. A thorough understanding of ppO₂ is the most important aid to safe rebreather diving. You need to know what happens to your ppO₂ when you descend, when you ascend, when your work rate increases and what risks are present at different stages of the dive. The following self check questions are designed to validate your understanding of the system and its use. Answers are included in Appendix 3.

- a. What are the risks when you first enter the water?
- b. What risks may become apparent during a surface swim prior to the dive?
- c. During the descent what is usually seen on the ppO₂ display?
- d. How often do you expect the solenoid to operate during the descent?
- e. Once below 20m what would be the effect of staying on the low (0.7bar) setpoint?
- f. Once on the bottom how often would you expect the solenoid to operate and for how long would the oxygen inject?
- g. What is the effect on the ppO₂ of adding diluent to the loop, for example after mask clearing?
- h. If an air diluent flush is carried out at:
 - 10m what will be the ppO₂ in the loop?
 - 20m what will be the ppO₂ in the loop?
 - 30m what will be the ppO₂ in the loop?
 - 40m what will be the ppO₂ in the loop?
- i. How often should you check your ppO₂ whilst on the bottom?
- j. Why is it important to check your ppO₂ prior to the ascent?
- k. As you ascend how often would you expect the solenoid to operate and for how long?
- l. How would this vary with ascent speed?

1.7 Setpoint Selection



A setpoint lower than 1.0 bar is used at the surface, the default every time you progress the handset into dive mode and manufacturer's preference is 0.7 bar. This setpoint is only suitable for shallow dives, so a higher setpoint should be selected during the descent.

On the Recreational 1 (17m) and Recreational 2 (40m) versions the setpoint is changed GRADUALLY and automatically for you, increasing as you descend and decreasing as you ascend. It changes in 0.1 bar increments between your high and low setpoint values, according to the table below:

Low Setpoint	0.7	
High Setpoint	1.3	
Depth (m)	Descent	Ascent
1	0.7	0.7
4.9	0.7	0.7
6.8	0.7	0.8
7.1	0.8	0.9
8	0.8	0.9
8.7	0.8	0.9
9	0.8	1
9.6	0.9	1
10.6	0.9	1
11	0.9	1.1
12	1	1.1
12.5	1	1.1
13	1	1.2
14.4	1.1	1.2
15	1.1	1.3
16	1.1	1.3
16.9	1.2	1.3
18	1.2	1.3
19	1.2	1.3
19.3	1.3	1.3
20	1.3	1.3

On the Nitrox and Trimix versions there are three methods of changing setpoint. GRADUAL (as above), Manual and AUTO. Which setpoint change method you use very much depends on the type of dive you are doing.

The advantages and disadvantages of the three setpoint change methods are highlighted below:

	Method	
1	Manual	<p>Advantage: allows you to change setpoint when you want to Disadvantage: occasionally you will forget to change setpoint and you will incur more decompression obligation. When Manual setpoint change is selected the setpoint indicator is shown as:</p>  <p>To operate: Press and hold the centre button for 2 secs to change from Low setpoint to High or High to Low.</p>
2	AUTO	<p>Advantage: the setpoint automatically changes at the best depths to eliminate spiking on descent and to optimise the ppO₂ for decompression reduction.</p> <p>Disadvantage: If you dive shallower than the low to high setpoint switch depth you will have to manually change to the high setpoint (which you can do at any time from the AUTO setting). e.g. If you set the switch depth at 25m, any dives where the bottom is between 12m and 25m, where the high setpoint should be used, you would either have to change the settings prior to the dive or manually override during the dive by pressing and holding the centre button for 2 secs. With that proviso this is the preferred method.</p> <p>To operate: Pre-select the depth where you want to change from Low to High on descent e.g. 25m and the depth where you want to change from High to Low e.g. 3m on a square profile decompression dive, but maybe 10m on a reef dive where you want to spend time in the shallows at the end of the dive where decompression may not need to be optimised.</p> <p>When Auto setpoint change is selected the setpoint indicator is shown as:</p>  <p>At any time the diver can manually switch to the low setpoint by pressing and holding the centre button.</p>
3	Gradual	<p>When Gradual setpoint change is selected, the setpoint indicator is shown as:</p>  <p>With this setting, the setpoint will change automatically and gradually as you descend and as you ascend. It changes in 0.1 bar increments between your selections of high and low setpoint values. Suggestion: leave the setpoints on the default values of 0.7 and 1.3 .</p> <p>Disadvantage: the Gradual setpoint change method does not optimise the setpoint for minimum decompression or faster descents but it has real advantages on those dives where minimal or no decompression is required.</p> <p>Advantage: It's a set and forget option; after you have selected it, it will be good enough for the majority of dives for many divers. It has the distinct advantage of easier buoyancy control during ascent which makes it ideal for beginners & so is the method chosen for Recreational 1 and 2 . At any time the diver can manually switch to the low setpoint by pressing and holding the centre button. If such a switch is made the letter L will be displayed next to the setpoint. Pressing and holding the middle button again will change the setpoint selection back to Gradual and the setpoint appropriate for the depth will be chosen.</p> <p>e.g. If the default setpoints of 0.7 and 1.3 are selected, the setpoint will automatically change in 0.1 increments starting at 7.1m and reaching 1.3 bar at 19.3m. 1.3 bar setpoint will then be retained until you ascend above 14.4m where it will start to decrease the setpoint in 1m increments, reaching 0.7 bar at 4.9m.</p> <p>Note: if you change the setpoint switch method from Gradual to Manual or Gradual to Auto, the Low setpoint will be chosen. In Auto Mode, the depth will then be measured and then High setpoint selected if you're deeper than your switch depth.</p>

The low setpoint is used at the surface. On “Manual and Auto” setpoint change, the depth at which you change to the high setpoint depends on the target depth. It is recommended that you stick to the VISION’s default settings of 0.7 bar for the low setpoint and 1.3 bar for the high.

Points to bear in mind:

1. By selecting the High setpoint on shallow dives down to 9m you are requesting the controller to maintain a high oxygen percentage in the loop. The oxygen controller will have to work hard to add sufficient oxygen, inducing a buoyancy control problem. During these dives it is easier to continue to use the low setpoint. If the high setpoint is definitely required at these shallow depths, then gas will have to be purged from the loop when positive buoyancy is experienced, until the gas in the loop is close to the required setpoint. This is achieved best by venting gas from the pull cord exhaust valve on the exhale counterlung.
2. For dives with the target depth laying between 10 and 20m use the low setpoint for the whole descent and change to the high setpoint at the target depth, this prevents ppO_2 from spiking and minimises decompression.
3. For dives to depths of 20m+, to prevent the ppO_2 from spiking, delay the switch to high setpoint until you are between 20 to 30m (e.g. 25m).



The VISION has an Auto setpoint change option for the descent but care must be taken to ensure the dive is conducted on the correct setpoint.

Except when using the GRADUAL method of setpoint change, ascents and decompression are normally done using the same setpoint as the bottom portion of the dive (1.3). During ascent the oxygen controller will be adding oxygen all the time, to maintain control of your buoyancy you will need to vent gas from the pull cord exhaust valve on the exhale counterlung. This method of releasing gas from the loop reduces oxygen usage, compared to venting from your nose.

If you attempt to surface from the deco stop whilst using the High Setpoint, constant inflation/solenoid injection will be experienced as the ambient pressure is equal or less than the setpoint, i.e. if the high setpoint is 1.3, then from 3m upwards the O_2 controller will be continually injecting oxygen or if your setpoint is 1.5 then it will be continually injecting from 5m upwards. This continual inflation will bring you to the surface unless gas is purged from the breathing loop. To avoid this, the setpoint may be changed to the low setpoint, either by presetting the switch depth in the menu or by manually pressing and holding the centre switch. However, in the event the diver ascends above the 100% O_2 depth (3m- 1.3 bar) the VISION with AUTO setpoint switch activated, automatically changes back to the Low setpoint.

Buoyancy Control in the shallows is difficult at first. You need a lot of practise before you do real decompression dives!



Be sure to check you are using the High Setpoint when on the bottom, to ensure reduced on-gassing. Be sure to monitor the ppO_2 to ensure that it is close to the setpoint. Variations away from the setpoint will affect your dive planning for decompression.

Alternatively, the Gradual method of changing setpoint may be chosen:

With this setting, the setpoint will change automatically and gradually as you descend and as you ascend. It changes in 0.1 bar increments between your high and low setpoint values.

Remember: check the ppO_2 display every minute. Know your ppO_2 at all times!

The depth at which you change very much depends on the depth you are diving to. On a 30m dive, if you change too shallow, e.g. 10m, you will get ppO_2 spikes as you pass 22m unless you descend extremely slowly.

1.8 Pre-dive Checks

Pre-dive checks are essential to safe rebreather operation. Many problems encountered underwater stem from inadequate pre-dive checks and would be avoided altogether with a proper pre-dive routine. To aid pre-dive checks you will find check lists in the rear of this manual which can be copied and laminated and used at the dive site.

1.9 Descending

At first you may find it difficult to submerge. The problem is that air is held in four locations: the dry suit; the BC; the counterlungs; and in your own lungs.

Whilst on the surface, concentrate on removing air from the BC and dry suit. Once this is done the only air to be vented is that in your lungs and the rebreather's counterlungs. By continually breathing in through your mouth and out through your nose, you will quickly deplete the retained gas and reduce the buoyancy. Depending upon your weighting, it may be necessary to do a "duck dive" in order to submerge. At a depth of 1 to 2 m you will attempt to take your first breath. You will probably be unable to do so because of the external pressure squashing the counterlungs. At this time you should press the diluent inflator with your left hand, operating it in short bursts until you have sufficient gas volume to take full, deep breaths. Practise the use of the diluent inflator before entering the water.

If an Automatic Diluent Valve (ADV) is fitted and connected to the diluent supply, the diluent addition will take place automatically on descent or whenever the loop volume is insufficient for inhalation. Diluent addition will take place whenever the pressure in the counterlung is substantially lower than the ambient pressure.

Descend slowly to avoid ppO_2 overshoot. Normal descent speeds are possible using the low setpoint but extreme caution must be taken if the high setpoint is used during descent.

At 6m check your equipment for leaks by looking upwards for tell-tale bubbles.

1.10 Mask Clearing and Pressure Equalisation

During the descent the pressure in your mask will have to be equalised by exhaling through your nose. This should be kept to a minimum as exhaling through the nose depletes the counterlung volume. During your instruction you will have been advised not to exhale through the nose. However, it is beneficial to try this during familiarisation with the apparatus, in a safe environment, to experience the effect it has on the counterlung's volume, your ability to take another breath and the importance of being able to properly locate the diluent inflator.

Remember: if you continually breathe out through your nose you are effectively on open circuit and your gas endurance will be greatly diminished.

1.11 Mouthpiece

It is important to close the mouthpiece before removing it, both underwater and on the surface. Failure to do so will result in loss of buoyancy and water entry. Practise opening and closing this valve before entering the water. The mouthpiece must be fully open in use to prevent water ingress through the drain port.

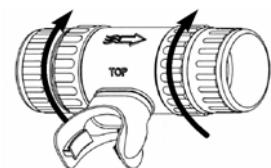

1.12 Ascending

To prevent lung damage during the ascent when using open circuit equipment, you would simply breathe out. Unfortunately, with a rebreather this will only increase the volume of gas in the counterlungs. Unless air is vented during the ascent you will notice both the counterlungs inflating and an increase in exhalation resistance. Eventually the variable exhaust valve will vent. The low pressure setting on the exhaust valve has a release pressure below that which would over pressurise human lungs. However, you will find it difficult to control your ascent speed if you rely entirely on this valve. It is therefore best to vent the loop yourself, before the overpressure valve operates. The aim is to maintain neutral buoyancy and retain enough gas in the breathing loop for one full, deep breath. When possible, practise your first ascents up a shot or anchor line.

There are three ways to manually vent gas from the loop:

1. Dump air periodically using the pull cord knob on the dump valve, the same method as used with a buoyancy compensator. This is the most efficient method, you use less oxygen.
2. Exhale through the nose. This is effective for dumping gas from your lungs but the pressure in the counterlungs will continue to increase as you ascend, so it is important to continually breathe gas from the counterlung and out through your nose. In practise, it is easier to exhaust air around the outside of the mouthpiece, whilst exhaling. This dumps air from both the counterlung and from the lungs simultaneously. (This method however results in greater oxygen usage. The solenoid is injecting oxygen into the lid and you are expelling the oxygen out of the loop so it will take a long while to reach setpoint and will waste oxygen during ascents.
3. One of the easiest methods is to simply hold the dump valve open for the complete ascent. As the gas volume increases it is exhausted from the counterlungs automatically. However, you must continue breathing.

Do not forget to vent gas from your dry suit and buoyancy compensator during the ascent.



WARNING! Always ensure the over-pressure valve is set to the “Dive” position.

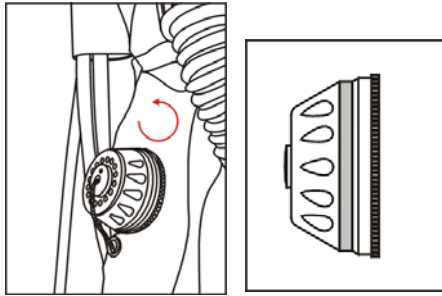

Low pressure setting – DIVE.

If this valve leaks gas, it will normally be because your counterlungs are floating off your shoulders. **DO NOT** stop the leak by partially closing the valve (rotating the cap clockwise), simply pull the counterlungs down onto your shoulders.



WARNING! Great care must be taken to avoid uncontrolled, ascents. If you are stuck in a fast ascent, hold the counterlung dump valve open and exhale rapidly and continuously. Alternatively, exhale rapidly and continuously round the outside of the mouthpiece.

1.13 Breathing Resistance

The Work of Breathing of the Inspiration, Evolution and Evolution+ meets the requirements of EN14143 at a breathing rate of 75 lpm at 40m with an air diluent and at 100m with a Trimix diluent providing the END is 24m or shallower. The over-the-shoulder counterlungs provide the least static lung pressures for overall ease of breathing in each orientation of the diver. Please note that the volume of gas in the counterlungs greatly affects the breathing characteristics. **The volume of gas in the counterlungs is controlled by you.** Too much gas will make it difficult to exhale and with too little it will be difficult to inhale. The ideal method is to retain only just enough gas in the counterlungs for one deep breath.

Gas may be added to the counterlungs by using the diluent inflator located on the left counterlung, the inhalation counterlung. Be sure to use this inflator and not the oxygen inflator on the right or your dry suit inflator. Rehearse the operation of the diluent inflator before entering the water. This is very important, apart from the fact that it needs to be second nature to find it, you need to ensure gas is flowing to this inflator before submerging.

1.14 Counterlung Choice

The over-the-shoulder breathing bags/counterlungs are available in three sizes – medium, large and extra-large. Select the counterlungs according to your body size. All counterlungs have sufficient breathing volume for anyone. See section 4.2 for more details.

The optional rear mounted counterlungs are available in one size. In order to fit different body sizes it's position can be adjusted vertically by using the alternative mounting holes.

1.15 Gas Consumption

The gas consumption from each cylinder for a 1 to 1¹/₂ hour dive under normal conditions will only be:

2 litre cylinders = 45-60 bar

3 litre cylinders = 30-40 bar

If you are using more than this your close circuit diving techniques should be examined.

Exhaling through your nose: If you carelessly exhale often through your nose you lose gas from the breathing circuit (the loop), you then have to add diluent to allow you to breathe, this lowers the ppO₂ and so the oxygen controller opens the solenoid to bring the ppO₂ back up to setpoint, so in fact you use gas unnecessarily from both cylinders.

Swimming over objects uses gas: Swimming over an object often requires a vent of gas from the buoyancy compensator and/or counterlungs. If a vent from the counterlungs is necessary then diluent addition will be required as you descend again back to your original level, this weakens the ppO₂ so the oxygen controller compensates by adding oxygen to bring it back up to setpoint. Again you use gas from both cylinders. Swim around objects if you can rather than swim over.

Ascents: The time when the system uses most oxygen is during the ascent. The ppO₂ drops with the decreasing ambient pressure and the oxygen controller opens the solenoid often and for longer periods than during other times on the dive. You must vent the loop during the ascent but if you vent the loop around your mouth then virtually all of the fresh oxygen added by the solenoid is dumped overboard, a big waste of gas. What you should do, particularly if the oxygen supply is diminished is use the pull cord dump valve to vent the loop. This way some of the fresh oxygenated gas is used for metabolism and some goes back around the loop to raise the ppO₂ around the oxygen sensors, reducing the opening time of the solenoid for the next injection and increasing the time between injections.

Dry Suit: your dry suit dump valve may be exhausting accidentally when you roll over.

Learn to look out for gas leakage in addition to checking the gauges. Do not be lulled into a false sense of security and do check the gauges regularly.

1.16 System Integrity - Leaks

It is extremely important to cure any leaks before diving. A small leak is irritating and saps confidence.

Be aware that it is very unusual to lose buoyancy or gas from the breathing loop. If there is a need to often inject diluent to breathe from the bag then it is very likely that there is a leak in the system. The other problem is that this constant injection of diluent lowers the ppO₂ in the loop and this may increase your decompression obligation.

Test the complete apparatus for positive pressure leaks by closing the exhaust valve by rotating it clockwise to the pre-dive/test position and either inflate by mouth, closing the mouthpiece afterwards, or by using the diluent inflator. One of the most practical methods of testing for leaks is to inflate the system using the diluent inflator until the pressure relief valve operates. If the counterlungs remain firm for over 40 minutes then there are no significant positive pressure leaks on the system. Ensure the exhaust/pressure relief valve is set to the low pressure position (fully anti-clockwise) prior to diving.

Test with negative pressure by sucking a vacuum on the apparatus, crush one or two of the convoluted hoses whilst sucking the vacuum and then close the mouthpiece. If air leaks into the system the crushed hoses will spring back towards their original shape. **It is extremely important to find any small leaks and rectify them before diving.** Water will ingress into the apparatus through the smallest of leaks.

Water in the exhale tube will be apparent because of an audible gurgling noise. If, despite continually clearing it by closing the mouthpiece, holding the mouthpiece overhead and shaking it, water is still apparent, it may be entering around the outside of the mouthpiece. Also, confirm the mouthpiece is fully open. As the mouthpiece is opened and closed, an O ring seal which is used to seal the inner tube against the outer, will be seen. If the mouthpiece valve is only partially open, an O ring will be visible when viewed through the mouthpiece and water will be allowed to enter the loop from the water vent. Finally, ensure the mouthpiece ty-rap is secure. Incorrect tensioning during replacement could result in a leak.



It is important to keep the unit upright if water is suspected to have entered the scrubber. If it cannot be stood upright lie it face down on its counterlungs, not on its back. Lying face down and upright prevents the Sofnolime and water from damaging the oxygen sensors, shorting the batteries or corroding the wiring.

1.17 Check for Water

During a dive it is good practise to periodically check for water ingress: roll on your left side and then roll on your right side, exhaling in each position. If gurgling can be heard when on your left, the water is most likely located on the exhale non-return valve in the mouthpiece, this can be moved by rolling on your right side, and then go slightly head up. The water will then pour into the exhale counterlung and it can stay there for the duration of the dive. Shaking the exhale convoluted hose at the same time will help any small water drops on their way. If gurgling can be heard when on your right side, the water is most likely in the bottom of the scrubber. Care must be taken at this stage not to go head down as this will allow water to flood through the sofnolime, dumping a Calcium Hydroxide and Salt/chlorine water combination over the oxygen sensors, batteries and wiring which will need careful cleaning before further use. Momentarily swimming on your right whilst exhaling and listening for gurgling is a good test to do as you swim back to the boat, gurgling when on your right means you have water in the bottom of the scrubber and you will need to advise the crew to **NOT** lie the rebreather down.

1.18 Flooding and Clearing Drills

Small quantities of water stuck in the exhale hose may be moved into the exhale counterlung using the technique in the paragraph above (rolling on your right and tipping up). A more thorough technique is to remove the closed mouthpiece, hold it above your head and either shake the hoses or simply stretch them slightly to get any water out of the convolutions.

During training it is necessary to conduct flooding and clearing drills. Do these at the end of a pool session. During these drills, try not to allow water into the scrubber but if water is allowed in **STAY** upright, get out and drain the scrubber **BEFORE** lying it down.



Something to remember during the drill: the water trap in the exhale counterlung cannot do its job if the counterlung is sucked flat, so always leave some gas in the exhale counterlung. If you don't, water coming in from the mouthpiece will go straight into the scrubber instead of the exhale counterlung.

1.19 Water Management

Firstly, drain all the water from the rebreather prior to the dive. Particular care should be taken just after disinfection. Any disinfectant must be fresh water rinsed from the rebreather prior to diving and particular attention must be paid to ensure the inhale counterlung is dry. It can be disconcerting to inhale water as soon as you do a duck dive.

Try not to allow water into the loop at all. This is best achieved by ensuring:

1. the rebreather is leak proof before getting in the water
2. the mouthpiece is not removed when it is open
3. the mouthpiece is fully open when breathing from the loop
4. you don't allow water in around the mouthpiece

If water is allowed in, it needs to be moved out of harms away into the exhale counterlung. The exhale counterlung can take quite a lot of water without impeding the breathing. Once you have water in the exhale counterlung though, avoid swimming head down as this will allow water to work around the water trap and enter the scrubber.

Although it is quite acceptable for a small amount of water to sit in the bottom of the scrubber it can start to impede breathing, gurgling will be heard particularly when swimming on the right side (the bottom opening of the side tube is covered with water). It is important for the scrubber's side tube to be against the diver's back so it will warn the diver of the water presence.

IMPORTANT: Do not tip head down. Great care must be taken to remain upright until the water is emptied from the bottom of the scrubber. Never tilt forward far enough for the water to run downhill through the Sofnolime.

Is there too much water in the loop? – water increases the breathing resistance, if you are finding it hard to breathe you have to either bail out to open circuit or clear the water.

If In doubt – bail out.

Notes:

1. Try not to allow water in.
2. If you allow water in move it into the exhale counterlung and try to keep it in there.
3. Try not to allow it to go further round the loop into the scrubber.
4. If water gets into the scrubber, ensure it is not allowed into the top of the scrubber, stay upright preferably or lean slightly forward and allow the water to soak into the used Sofnolime.
5. Under no circumstances go head down.
6. If large quantities of water continue to enter the loop, eventually it will be virtually impossible to breathe and this is indicated by the exhale counterlung being completely inflated and the inhale counterlung being completely deflated.

1.20 System Integrity - Indications

Know your ppO₂ at all times! Learn how to evaluate the information provided by the oxygen controllers - Sections 3.5 and sections 5 to 11.

Listen out for the solenoid, it should be operating in short bursts. If you think it has been open longer than normal or it has not been heard for a long while, it is time to take a look at the ppO₂ display.

Compare the cell readings. While breathing, the cell readings change. Bearing in mind that these oxygen cell readings are shown in real time, the ability to see all three sensors simultaneously is a great diagnostic aid. If one is failing to react as quickly as the others, there may be water on the cell's sensor face. The modifications made to the sensors prevent large quantities of moisture reaching the face and affecting the internal circuitry. It is, therefore, essential to use only oxygen cells supplied by Ambient Pressure Diving.

1.21 Batteries

Each oxygen controller has its own battery compartment and circuitry. It is imperative to ensure that both B1 & B2 lids are fastened properly. The 3-Volt Lithium batteries (2 x 3 Volt batteries per compartment) – Fujitsu or Energiser CR123 are readily available.

From firmware version 05.01.00 only battery B1 is used during calibration and to power the solenoid/handset. Should B1 drop below a pre-determined voltage the power drain will automatically be changed to B2. Should B2 also reach the pre-determined voltage then power will be drawn automatically from both batteries.

Should the ppO₂ fall below 0.4 bar the power is drawn from both batteries.

This method preserves battery B2 better than V01.00.04 where B2 was used during calibration and whenever the ppO₂ was below 80% of setpoint (i.e. every time you change from low to high setpoint). Clearly B1 is used slightly faster in firmware V05.01.00 but helps ensure the reserve battery provides a better “parachute”.

The battery life varies from diver to diver due to the frequency of use of the backlight and the brightness setting. To ensure that the reserve power is as good as it can be and you get the best use from the batteries always discard the batteries in B1 compartment (nearest the solenoid) when the low battery level is reached, replacing them with the two batteries from B2 and inserting new batteries into the B2.

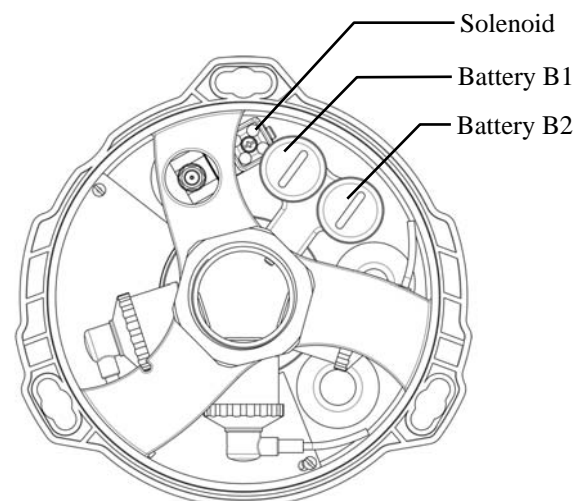



The electronics do not automatically power down when not in use, therefore it is very important to ensure that it is switched off after use to preserve battery life.



Never split open a double cylinder shaped battery (e.g. CRP2) to use the individual battery cells, the individual cells have different external dimensions to the CR123 and they will NOT work.



Never replace individual batteries from the same compartment, always replace both batteries simultaneously.



Never simply replace batteries in B1 with new batteries. B2 is depleted slightly during every dive and if not replaced there is a very real risk that B2 will not have sufficient capacity to power the B2 controller, should it be called into operation. Whenever inserting new batteries, they must go into the B2 slot, furthest from the solenoid, whilst replacing batteries from B1 with those from the B2 slot.



Always ensure the O-rings are clean of any debris and that the battery cap is screwed down sufficiently by using the slot to tighten.

1.22 Surface Swimming

When swimming forward, face down, on the surface, only partially inflate the BC. Over inflation will cause increased body angle and additional drag. Deflate the BC and adopt a horizontal, head down, streamlined swimming position.

1.23 Surface Buoyancy and Trim

By rotating the counterlung's pressure relief valve clockwise to the high-pressure setting, and with the mouthpiece closed, the counterlungs can be inflated and used for additional surface buoyancy. The volume of gas admitted into the BC must be regulated to ensure an upright floating position.

1.24 Quick Post-Dive Checks

Check the exhale counterlung for residual water by unscrewing the oxygen inflator. If water is present, drain and check the downstream side of the first water trap. Also, remove the scrubber and check the Sofnolime at the bottom of the scrubber, if it is soaked replace the Sofnolime before the next dive.



It is important to keep the unit upright if water is suspected to have entered the scrubber. This prevents the Sofnolime and water from damaging the oxygen sensors, shorting the batteries or corroding the wiring.

1.25 Practise

Learn to ascend without adding diluent. This enables you to surface normally, even in the event of having lost your diluent gas for some reason, perhaps you've given it to your dive buddy?

Learn to operate the system with the solenoid failed in the closed position. This may be achieved by manually adding O₂ to reach a ppO₂ of 0.9 when a ppO₂ of 0.7 is selected.

Learn to operate the system with the solenoid failed in the open position. Practice this in the swimming pool by selecting a high set point of 1.5 and controlling the injection of O₂ by opening and closing the cylinder valve.

1.26 Solenoid Operation

There are several basic requirements for CCR oxygen control:

1. It needs to maintain the ppO_2 as close as possible to the desired setpoint during high and low work-rates.
2. It needs to maintain the ppO_2 during ascents and reach setpoint rapidly once the ascent is halted.
3. It needs to be capable of maintaining the ppO_2 within life sustaining limits during rapid ascents.

The Vision's oxygen control has been proven with 3rd party assessment, SGS and QinetiQ, to meet all these requirements.

It does it with a unique oxygen inject sequence:

1. If the ppO_2 is above the setpoint, the solenoid is closed.
2. If the ppO_2 is 0.1 bar or more below the setpoint, the solenoid is opened.
3. Once the ppO_2 reaches 0.1 bar below setpoint the solenoid closes for 3 secs. Then it measures the ppO_2 again, and should the ppO_2 now lay within the 0.1 bar control zone, the solenoid is opened for a variable period dependent on how far the ppO_2 is from the setpoint. Close to the setpoint, the solenoid will only open for a fraction of a second, this way fine ppO_2 control is achieved and buoyancy control during decompression is made easier.

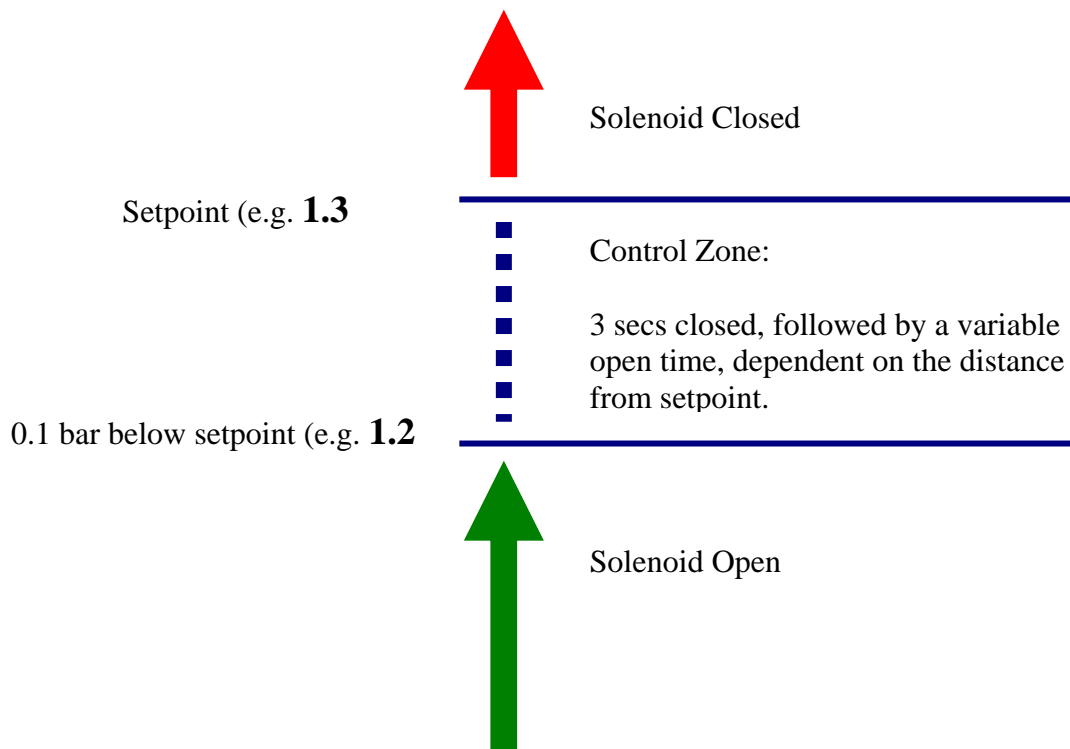

1.27 Auto-Activation

Auto-Activation has been added as a hardware feature to complement, in particular, the Recreational training requirements. There are two contacts which are located on different planes on the handset. Once submerged or wetted these are designed to activate the rebreather.

Note: this does not relieve you of the responsibility/need to switch the unit on before you enter the water. When you switch the handset on there are several automatic and essential power on self-tests conducted and it's important to switch the rebreather on and allow your rebreather to do these tests before jumping in.



WARNING: All auto-activation systems rely on battery power. If your batteries do not have sufficient voltage the auto-activation will not work, you will receive no warnings and if you combine this scenario with jumping in expecting it to work and not look at your handsets, the oxygen pressure will soon drop and you will lose consciousness and die if not rescued by another person.



WARNING: The auto activation feature will not function properly in pure water.

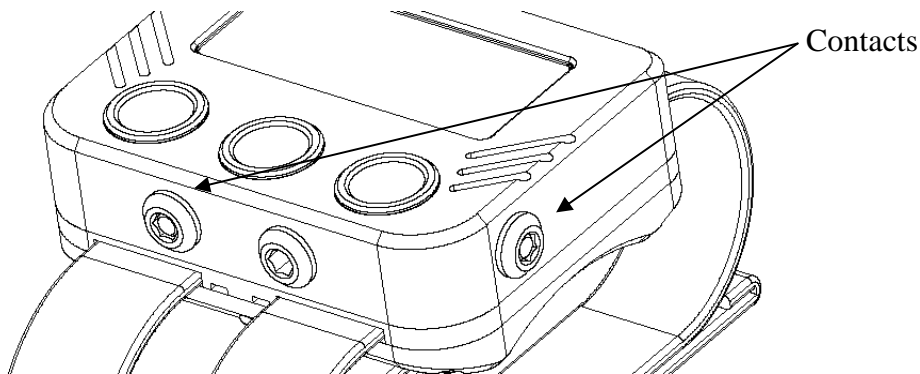

1.28 Solenoid operation and the main oxygen risks during the dive

PHASE	NORMAL SOLENOID OPERATION	OXYGEN RISKS	POSSIBLE CAUSES	CONCLUSION
Surface breathing	Closed 3 secs, Open when the ppO ₂ more than 0.1 bar below setpoint. Open < 1 sec when close to and below the setpoint	Hypoxia – HIGH risk	Hypoxia – oxygen cylinder valve closed, oxygen cylinder empty, solenoid jammed shut, oxygen controllers switched off.	Before the decent there is only one oxygen risk – Hypoxia or low oxygen pressure. Hypoxia can occur within a minute or so when on the surface. Look often at the ppO ₂ displays! Listen for the oxygen injecting.
Jumping In	Closed 3 secs, Open < 1 sec when the ppO ₂ is close to and below the setpoint	Hyperoxia – NO risk		
On the surface	Closed 3 secs, Open < 1 sec when the ppO ₂ is close to and below the setpoint			
Descending	Closed. Opens when setpoint changes to High, green HUD lights flash until PO ₂ is within 0.2 bar of setpoint	Hypoxia – No risk * Hyperoxia – SLIGHT risk	* Hypoxia – No risk, providing the oxygen content of the diluent is suitable for the shallows. Hyperoxia – manual addition of oxygen or solenoid jammed open	The main risk during the descent is the diluent. Is the diluent switched on? – Check this before you get in the water! Are you pressing the diluent button or the oxygen button? Left hand is diluent. (LEAN – left, RICH – right) Listen for the solenoid; it shouldn't be opening. If it does, check the ppO ₂ displays.
Bottom portion of dive	Closed 3 secs, Open < 1 sec when the ppO ₂ is close to and below the setpoint	Hypoxia – LOW risk Hyperoxia – HIGH risk	Hypoxia – oxygen cylinder valve closed, oxygen cylinder empty, solenoid jammed shut, oxygen controllers switched off. Hyperoxia – manual addition of oxygen or solenoid jammed open.	Hypoxia is a low risk simply because it takes so long to happen and you should be looking at the ppO ₂ displays, ensuring your ppO ₂ is close to the (HIGH) setpoint to ensure you don't suffer decompression sickness. Listen for the solenoid; you expect short bursts with 6 closed periods. If it is adding oxygen for longer than a fraction of a second then check your ppO ₂ displays.
Ascending	Closed 3 secs, Open > 1 sec . If the ppO ₂ falls more than 0.1 bar below setpoint the solenoid opens and stays open until the ppO ₂ is within 0.1 bar of setpoint.	Hypoxia – HIGH risk Hyperoxia – MEDIUM risk		Hypoxia – the ascent is potentially a very dangerous time. Check your ppO ₂ BEFORE the ascent and then often during. Listen for the solenoid, you expect long bursts of oxygen addition – the opening time will vary with your ascent speed but at normal ascent speeds it will be approx. 4 or 5 seconds followed by 3 seconds closed, increasing to continually open during periods when the ppO ₂ is more than 0.1 bar below setpoint.
Decompression Stop	Closed 3 secs, Open < 1sec when ppO ₂ is close to and below the setpoint	Hypoxia – LOW risk Hyperoxia – MEDIUM		Hypoxia is a low risk simply because it takes so long to happen and you should be looking at the ppO ₂ displays, ensuring your ppO ₂ is close to the (HIGH) setpoint to ensure you don't suffer decompression sickness – ensure you stay within the NOAA CNS guideline.
Surface swimming	Closed 3 secs, Open < 1 sec when the ppO ₂ is close to and below the setpoint	Hypoxia – High risk Hyperoxia – NO risk	Hypoxia – oxygen cylinder valve closed, oxygen cylinder empty, solenoid jammed shut, oxygen controllers switched off.	Hypoxia can occur within a minute or so when on the surface. Look often at the ppO ₂ displays! Listen for the oxygen injecting.

Do use the checklists at the back of this manual to aid preparation.

OXYGEN DANGER POINTS

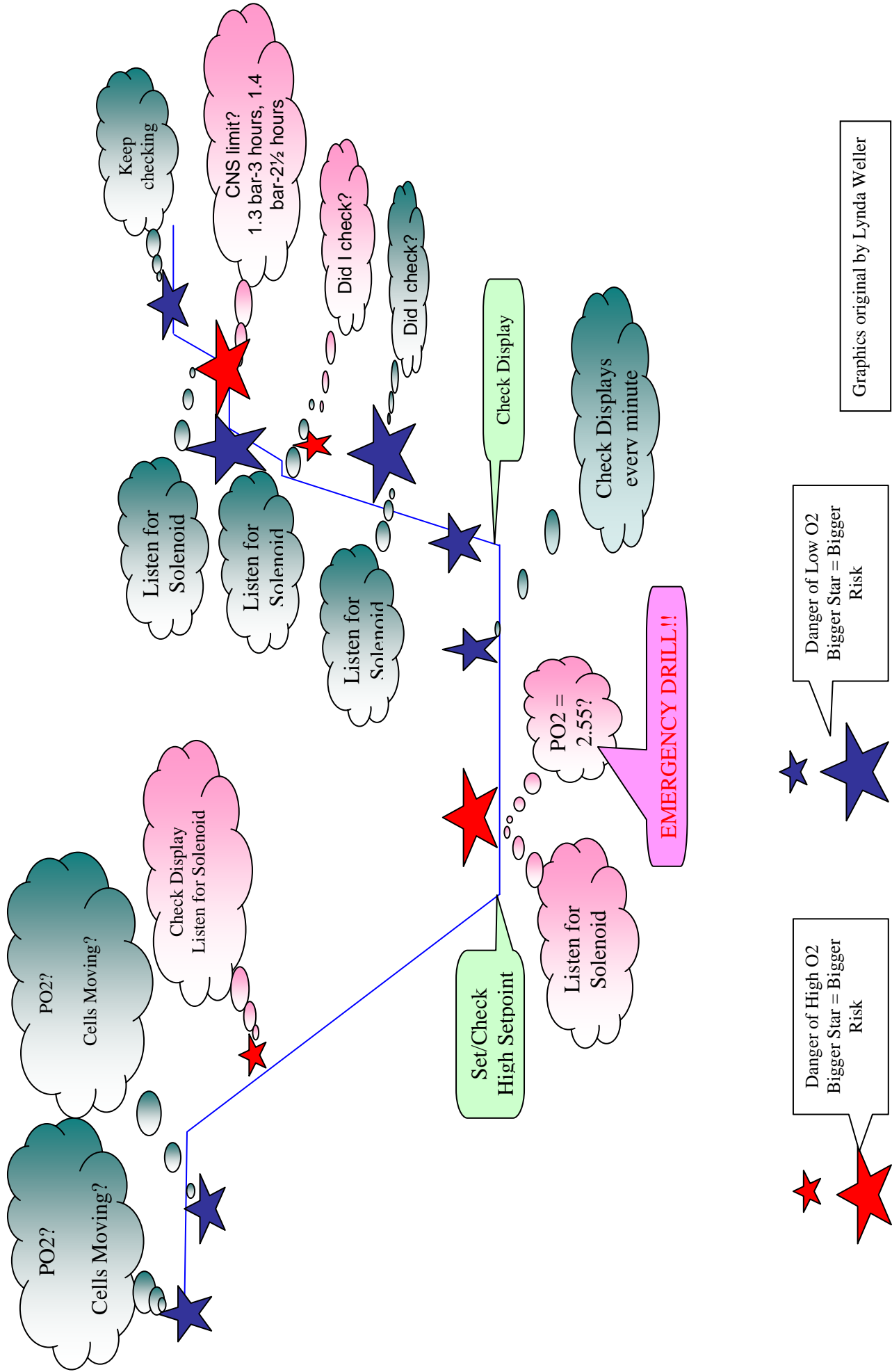

Graphics original by Lynda Weller

SECTION 2

2.0 DEFINITIONS

AMBIENT PRESSURE:	That pressure surrounding the diver/rebreather. Rough values are 1.0 bar at the surface, 2 bar at 10m, 3 bar at 20m, 4 bar at 30m etc. When calibrating the cells prior to diving, the ambient pressure is the atmospheric pressure on the day. This varies with altitude and weather.
B1 & B2:	Batteries 1 & 2. B1 is always used as the Master unless its voltage is too low when B2 will be promoted from Slave to Master status. B1 is the battery compartment for C1, B2 for C2. If B1 is missing or dead there will be no C1, C2 would be the Master. Experiment (on land) by starting the system with only one battery at a time inserted. The active or Master battery is highlighted on the wrist-mounted display.
BAILOUT:	An emergency breathing system.
BOTTOM TIME:	Time from leaving the surface to time of leaving the bottom.
BREATHING LOOP:	The entire breathing gas pathway including the diver's lungs and airways; the mouthpiece; the counterlungs; the convoluted hoses; and the scrubber.
C1 & C2:	Oxygen Controllers 1 & 2 are located in the lid of the scrubber. C1 is always the Master, controlling the solenoid activation, providing it has a battery in place with more than the threshold voltage and detects three active oxygen cells and detects the solenoid. It is possible for C1 to be active but using the power from B2 or later from B1 and B2 if both batteries are at the low battery warning level.
CALIBRATION:	All the oxygen cells have to be calibrated before use. This is a fairly simple procedure; it takes about 45 seconds to complete and is done on the complete unit prior to the dive.
CARTRIDGE:	Sofnolime is retained in a diver-refillable container/cartridge which is inserted into the scrubber.
CCR:	Closed Circuit Rebreather.
CELL WARNING:	This is displayed when the ppO_2 reading of one oxygen cell deviates by more than 0.2 bar from the average of the other two.
CEILING:	The decompression computer displays a "Ceiling" – the shallowest depth you may ascend to. It is NOT a decompression stop. Decompression MUST take place below the Ceiling Depth.

CNS OXYGEN TOXICITY:	Central Nervous System Oxygen Toxicity. Oxygen toxicity is a combination of oxygen pressure and time. The exposure limits are shown later in this manual.
CO ₂ :	Carbon Dioxide gas, a constituent of the exhaled gas mixture, poisonous if inhaled.
DILUENT:	Gas used to dilute the oxygen in the breathing circuit to reduce the ppO ₂ and allow dives below 6m. Usually air for dives to 40m.
E N D:	Equivalent Nitrogen Depth; used for determining the narcotic element of Trimix and critically determines the density of the gas in the breathing circuit.
EST	Estimated decompression required (seen in all version except Dive Timer). If the diver violates the decompression, by ascending above the ceiling for more than 1 min. the dive computer displays an “estimate” of decompression required. By moving outside the normal decompression envelope the user is subjected to extreme risk, even following the estimated decompression required decompression sickness is likely to occur.
HELIOX:	Gas used as a diluent consisting of Oxygen and Helium.
HIGH OXYGEN:	This is displayed when the ppO ₂ in the loop is 1.6 bar or higher.
HUD:	Head Up Display(s), an indicator using lights to show the system is in dive mode, warn of variations in oxygen pressure, battery warnings, cell warnings and bring the diver’s attention to the wrist display.
HYPERCAPNIA:	An excess of carbon dioxide.
HYPEROXIC:	For the purposes of this manual, hyperoxic is classed as all breathing mixtures with a ppO ₂ greater than 1.6 bar.
HYPEROXIC MYOPIA:	Short sight requiring corrective lenses, as a result of exposure to elevated oxygen pressures over time.
HYPOXIC:	When the ppO ₂ is less than 0.16 bar.
LOOP:	The Breathing Loop, or breathing circuit, includes the diver’s lungs, the mouthpiece, all convoluted hoses, counterlungs and scrubber.
LOW OXYGEN:	This is displayed when the ppO ₂ in the loop is 0.4 bar or less.

NO STOP TIME: The time remaining before decompression stops will be required during the ascent.

OTU: Oxygen tolerance unit (a measure of whole body oxygen toxicity).

OXYGEN CELLS: Cells or sensors used to monitor the ppO_2 in the breathing circuit (loop).

PULMONARY OXYGEN TOXICITY:

Whole Body oxygen toxicity from long dives over multiple days exposed to high oxygen pressures, see Hyperoxic Myopia.

ppO_2/PO_2 : Partial pressure of oxygen in the breathing gas - this you have to understand. It is the pressure of O_2 in the breathing gas that keeps you alive, you have to ensure the oxygen pressure is kept within life sustaining levels. To calculate the O_2 pressure (ppO_2) multiply the oxygen % by the ambient pressure.

	Air(21% O_2)	10/52	O_2
Depth(m)	ppO_2	ppO_2	ppO_2
0	0.21	0.1	1
1	0.231	0.11	1.1
2	0.252	0.12	1.2
3	0.273	0.13	1.3
6	0.336	0.16	1.6
10	0.42	0.2	2
20	0.63	0.3	3
30	0.84	0.4	4
60	1.47	0.7	7
80	1.89	0.9	9
100	2.31	1.1	11

The ppO_2 is shown here for three gasses, Air, 10/52 (10% O_2 + 52% He + 38% N_2) and pure oxygen. It can be seen that when breathed open circuit these gasses are un-respirable at some depths: Air, from a ppO_2 perspective, exceeds 1.6 bar at about 66m. The 10/52 will not support life in the shallows – you wouldn't want to breathe from this gas, with a moderate work rate shallower than 10m. Pure oxygen exceeds 1.6 bar at 7m and becomes increasingly toxic the deeper you go.

SCRUBBER/CANISTER: The complete, back mounted, canister used for CO_2 removal and, in this rebreather, oxygen analysis and oxygen addition.

SCRUBBER MONITOR: The area of active scrubber material is measured by the Temp-Stik and displayed top centre of the wrist mounted display on the scrubber monitor.

SETPOINT: The pre-selected setting about which the oxygen controller attempts to maintain the actual ppO_2 in the breathing loop.

SOFNOLIME: The absorbent used in the scrubber to remove CO_2 from the exhaled gas.

START ERROR:	This is displayed if the diver, <u>after</u> switching on, fails to proceed through the displays into Dive Mode and then descends below 1.2m .
TEMP STIK (patented):	The CO ₂ absorbent temperature probe which replaces the centre rod of the scrubber cartridge; gives information on the active area of the scrubber when exothermic CO ₂ absorbent is used.
TRIMIX:	Gas used as a diluent, consisting of oxygen, helium and nitrogen. See Appendix 7.
TTS	Total Time to Surface including decompression based on an ascent speed of 10m/min, assuming the last decompression stop will be at 6m.
LUBRICATION:	Any approved oxygen compatible grease. DO NOT USE silicone or hydrocarbon based grease or oil on high or medium pressure oxygen fittings.

SECTION 3

3.0 OPERATIONAL CONSIDERATIONS

3.1 General

The Inspiration, Evolution and Evolution+ are closed circuit rebreathers (CCR) in which the exhaled gases are re-circulated within the apparatus so the diver can breathe them again and again. A CO₂ scrubber chemically removes the CO₂ whilst the oxygen controller monitors the exhaled gases and, when necessary, injects oxygen to maintain the oxygen partial pressure (ppO₂) at preset levels, known as setpoints.

Oxygen is supplied directly from a cylinder containing pure oxygen. As the diver descends, gas needs to be added to maintain the breathing volume. Providing this gas has a lower oxygen content, it will dilute the oxygen and is known as a dilutant or diluent. By diluting the oxygen the diver can go deeper than the 6 m limit set for pure oxygen closed circuit rebreathers.

A rebreathers depth limit is governed by three factors. The first is the gas used as the diluent, the second is the volume of bail out/emergency breathing gas and the third limit is the greatest depth at which the rebreather has been formally tested - 100m, (depth is a significant factor affecting the duration of the scrubber). If air is used as a diluent then the rebreather can be used at all depths down to the air diving limit, 40m. Air is the diluent of choice for normal sport diving depths. Normal diving-quality compressed air is used.

Deeper than 40m a diluent of Heliox or Trimix (with a max. END of 30m at 70m, reducing to an END of 24m at 100m, see Appendix 7) is essential. If Trimix or Heliox is used as a diluent then, as with open circuit diving, the gas mixture limits the depth. It is not the intention of this manual to teach the diver how to dive using a pre-mixed helium based diluent, a separate course should be undertaken for that, but it is essential to prepare a diluent with a suitable Equivalent Nitrogen Depth (END) and a ppO₂ lower than setpoint if the diluent were to be breathed open circuit on the bottom or manually flushed through the breathing circuit.

The volume and type of bailout gas carried is extremely important in determining the depth range. It must be sufficient in order to breathe at depth and bring you back to the surface. Some deep mixes will not be respirable near the surface when breathed open circuit and in these circumstances an additional means of breathing life support gas must be provided. See Appendix 7 for Trimix and HeliAir mixes.

Refer to "Depth Limitations", Technical Data, Section 18.

The Inspiration, Evolution and Evolution+ are CE approved to 40m using an air diluent and 100m using an Heliox diluent or Trimix (with a max. END of 30m at 70m, reducing to an END of 24m at 100m).

The Inspiration, Evolution and Evolution+ rebreathers fitted with the APD Open-Circuit Bailout (OCB) mouthpiece can be used in-conjunction with the Ocean Technology Systems' Guardian full-face mask (FFM). A special full-face mask adaptor is available to fit the Guardian FFM to the OCB. No other type of FFM should be used with APD rebreathers. The classic type (white) mouthpiece which does not have the bailout option or purge function is not suitable to use with the Guardian FFM.

3.2 Gas Consumption

Only a fraction of the air we inhale, approximately 4% at the surface, is used, most of which is converted into CO₂ and exhaled along with the 96% of the gas not used. By re-circulating the exhaled gases, removing the CO₂ waste product and replenishing the oxygen, we can limit the gas removal from the oxygen cylinder to the same volume that we consume for metabolism, between 0.5 and 3.5 litres per minute depending on the person and work rate. The average diver consumes approximately 1 litre of oxygen per minute, women generally less. This means:

- a 3 litre cylinder filled to 200 bar contains 600 litres of oxygen and will last 9.9 hours
- a 2 litre cylinder filled to 200 bar contains 400 litres of oxygen and will last 6.6 hours

not allowing for extra O₂ used during ascents or reserves. The other incredibly significant benefit for the diver is that the amount of oxygen consumed is the same at all depths as shown in Table 1.

Table 1. Comparison of Gas Consumption between Open Circuit and Closed Circuit Apparatus (for a diver with a breathing rate of 25 litres per min)

Depth (m)	Absolute Pressure (bar)	Gas consumption (litres/min.)	
		Open Circuit	Closed Circuit
0	1.0	25	1.11
10	2.0	50	1.11
20	3.0	75	1.11
30	4.0	100	1.11
40	5.0	125	1.11
50	6.0	150	1.11
60	7.0	175	1.11
70	8.0	200	1.11
80	9.0	225	1.11
90	10	250	1.11
100	11	275	1.11

Diluent is used for volume make-up during descent phases. Once at the target depth no more diluent is used unless the breathing volume is reduced by gas wastage, such as mask clearing or exhaling through the nose, at which time more diluent will need to be added to the counterlungs to enable the diver to breathe without restriction. Diluent usage therefore, for the rebreather, is minimal. Typically, if the diluent is used for BC inflation, dry suit inflation as well as counterlung inflation a diver will only use 30 bar from the 3 litre cylinder per dive.

Diving with a full cylinder, filled to 232 bar, the remaining emergency gas reserve or bailout available will be:

- 200 bar for a 3 litre cylinder
- 180 bar for a 2 litre cylinder

Note: The cylinder may not be large enough for open circuit bailout on your planned dive – in this case an extra cylinder will be needed.

Diluent usage should be monitored and recorded during the training dives to use for future gas planning. Oxygen usage varies with diver work-rate, but is independent of depth, and is approx. 0.044 times the diver's Respiratory Minute Volume (RMV).

Extra oxygen is injected into the breathing circuit during ascent phases to maintain the ppO_2 , and must be allowed for. Again, the typical consumption rate is:

- 30bar for a one hour dive using 3 litre cylinders, 50 bar for a two hour dive
- 50bar for a one hour dive using 2 litre cylinders, 90 bar for a two hour dive

However, your own O_2 usage should be monitored and recorded during the training dives to use for future gas planning.

3.3 Oxygen Benefits

Background:

Air at the surface is approximately 21% oxygen, 79% Nitrogen. The Absolute Pressure at the surface is approximately 1 bar. According to Dalton the partial pressure of oxygen (ppO_2) is 0.21 bar and the partial pressure of the Nitrogen (ppN_2) is 0.79 bar: $0.21 + 0.79 = 1.0$ bar. Referring to Table 2 you can see the ppO_2 and ppN_2 at the different depths when breathing open circuit SCUBA. The ppN_2 is simply derived from multiplying the ppN_2 at the surface by the ambient pressure, i.e. at 10 m, the $ppN_2 = 0.79 \times 2 = 1.58$. The ppO_2 is calculated in exactly the same way, at 10 m the $ppO_2 = 0.21 \times 2 = 0.42$.

The oxygen partial pressure in the rebreather is monitored by three oxygen cells. As the diver is consuming oxygen through their metabolism, the partial pressure drops. Once it drops below a predetermined level, known as the setpoint, a solenoid valve is opened and oxygen is added.

By controlling the pressure of oxygen in the loop we have the opportunity to maintain higher ppO_2 levels than that experienced on open circuit, decreasing the decompression obligations and giving us either increased no-stop time or an increased safety margin.

Table 2 shows a comparison between a diver on SCUBA, breathing air, and a diver on closed circuit rebreather with a setpoint of 0.70 bar on the surface and a setpoint of 1.3 bar for the dive. Comparing the ppN_2 of open circuit AIR and the ppN_2 when on closed circuit it can be seen that the closed circuit diver has a lower nitrogen loading at all depths down to 50m. But it can also be seen that the breathing mixture becomes richer in oxygen whilst ascending, reaching 100% oxygen at 3m. This has the positive effect of giving the diver oxygen-rich decompression on every dive, resulting in quicker off gassing of nitrogen.

Table 2 Comparison of Open Circuit and Closed Circuit Apparatus

Absolute		Open Circuit (AIR)				Closed Circuit			
Depth (m)	Absolute Pressure (bar)	ppO_2 (bar)	O_2 %	ppN_2 (bar)	N_2 %	ppO_2 (bar)	O_2 (bar)	ppN_2 (bar)	N_2 %
0	1.0	0.21	21	0.79	79	0.70	70	0.3	30
3	1.3	0.273	21	1.027	79	1.3	100	0	0
6	1.6	0.336	21	1.267	79	1.3	81	0.3	19
10	2.0	0.42	21	1.58	79	1.3	65	0.7	35
20	3.0	0.63	21	2.37	79	1.3	43	1.7	57
30	4.0	0.84	21	3.16	79	1.3	32	2.7	68
40	5.0	1.05	21	3.95	79	1.3	26	3.7	74
50	6.0	1.26	21	4.74	79	1.3	21	4.7	79

3.4 Decompression

The VISION electronics has a built in dive timer and depth gauge as standard which is easily upgraded to either a Nitrox or Trimix decompression computer by purchasing the downloadable software release key. www.apdiving.com

Alternatively, a constant ppO_2 dive computer such as the Buddy Nexus can be used to take full advantage of a rebreathers reduced-deco potential.

Alternatively, Constant ppO_2 decompression can be calculated using a software program such as the APD Dive Planner. A set of tables, showing no-stop times, is at Appendix 4 of this manual. These tables have been calculated on DDPlan for the standard 1.3 bar setpoint. It can be seen that the no-stop time for 20m with a setpoint of 1.3 bar is 140 mins. This compares to 51 mins on AIR on a Bühlmann table.

Alternatively, a standard Nitrox dive computer can be adjusted to the oxygen percentage at the target depth with the planned setpoint. With a setpoint of 1.3 bar the oxygen percentage in the rebreather at 30m is 1.3 divided by 4 = 0.32, i.e. 32%. Setting the dive computer to 32% would be a very conservative way of calculating the decompression requirements because the dive computer would assume a constant gas percentage at every depth, whereas much higher oxygen percentages would be breathed during the shallower phases of the dive. However, in practical terms this is a very easy method to achieve long duration dives with all the benefits of breathing Nitrox. Using a Nitrox dive computer is of most use when 3 or 4 dives are scheduled per day or multi-level dives are conducted.

3.5 Oxygen Controllers

The oxygen control system consists of three oxygen cells, two control units with their own fibre optic Head Up Displays and batteries, one solenoid valve for oxygen addition and a wrist mounted screen display with control switches. The two oxygen controllers, C1 and C2, are encapsulated and are located in the scrubber lid moulding. The C1 control unit is generally the Master control unit and the C2 control unit is the Slave. If for some reason C1 is incapable of being the Master then C2 will be the Master. The Master controller is shown at the top of the display next to the setpoint. The Master unit controls the oxygen solenoid and hence the breathing mixture whilst the Slave gives a secondary measurement but is ready to take over if the Master controller fails. You can simulate this by switching off the Master controller (through the Power Shutdown sequence), the Slave becomes the Master within 1 second.

3.5.1 Accuracy of the Oxygen Controller

The oxygen controller displays the ppO_2 as measured by all three cells. The accuracy is ± 0.05 bar and this should be taken into consideration when dive planning. If the setpoint is 1.3 bar, assume 1.25 bar when calculating decompression and 1.35 bar when calculating oxygen toxicity time limits.

3.5.2 Oxygen Cell Life

The cell manufacturer does not guarantee the cell life, as it varies with usage. In the Inspiration, Evolution and Evolution+ it is expected that the cells will last between 12-18 months. This largely depends on their treatment and importantly the ppO_2 the cell is stored in. Vibration, excess temperature, excess moisture and direct sunlight can adversely affect the cells. It is not recommended to store the oxygen cells in a sealed bag or in an inert gas but simply return the gas around the cells to Air (i.e open the scrubber lid). When travelling to remote spots it is advised to take spare oxygen cells and batteries. However, oxygen cells will be consumed even in their storage bag and eventually will be unusable. They will last longer inside the bag than out but only marginally so.

3.5.3 Interpreting the ppO_2 Displays

On initial power up, the output from the cells is compared. If they are outside the expected range, cell failure warnings are displayed and the oxygen controller will not proceed to dive mode.

The oxygen controllers display the ppO_2 measured by all three oxygen cells and display in the range 0.0 to 2.55 bar. Remember that the ppO_2 level must remain between 0.16 and 2.0 bar to sustain life. If 2.55 bar is seen on the display - **do not hesitate** - perform a diluent flush immediately and consider reverting to open circuit. 2.55 bar on the display could indicate either a malfunction in the electronics or a very high ppO_2 . In the latter case the ppO_2 level could be very high indeed e.g. 6 bar at 50m! (The maximum displayable value is 2.55 bar)

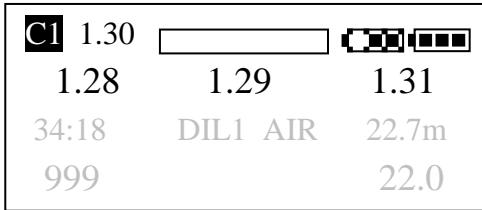

During the dive the oxygen controller controls the oxygen partial pressure in the breathing loop by averaging the nearest two cell output readings, i.e. if you have one cell reading 1.28, another 1.29 and the other 1.31, the cell displaying 1.31 will be ignored and the ppO₂ assumed to be 1.285. As it is below the setpoint, the solenoid will open for a fraction of a second.

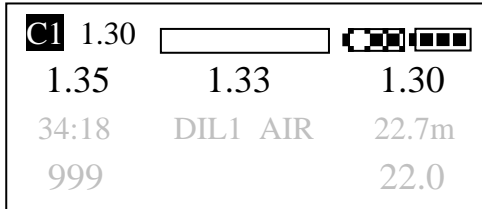

In this example the ppO₂ is assumed to be 1.34 bar, i.e. above the setpoint, so the solenoid will not open.

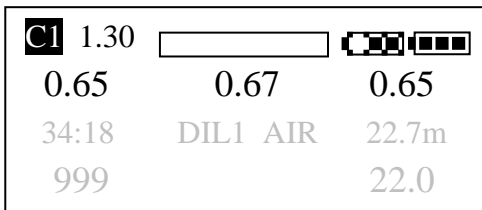

In this example the ppO₂ is assumed to be 0.65 bar, which is a long way below the setpoint, so the solenoid will open for a number of seconds.

The ppO₂ is shown for all three cells.

By displaying all three cells simultaneously it allows you to instantly diagnose the problem. Any slow reacting cells can be spotted, along with any physical faults such as a faulty connection to a cell. If a cell reads 0.0 bar then a wire or connector has become disconnected or the O₂ cell is faulty. If a cell is inoperative abort the dive and consider manual operation or bailing out. Excess oxygen in the loop may be prevented by controlling the oxygen cylinder's valve. If more oxygen is required, press the oxygen inflator. See Section 14 - Emergency Procedures.

3.5.4 Voting Logic

The ability to interpret how the rebreather is behaving and to validate it yourself with gas flushing is what we believe an essential skill. Part of that understanding is seeing how the cells react to gas additions whether they be manual adds or from the solenoid which is why we show all three cells to two decimal places, close to real time rather than showing an averaged ppO₂ display which would move slowly. Another key element is knowing what the machine is thinking and basing its decisions on rather than show you a “manufactured” ppO₂ display. For that reason a simple voting logic is used – the average of the nearest two is assumed to be the correct value, so anyone even under stress can tell what the machine believes the ppO₂ to be. The Voting Logic is enhanced with another simple system – “cell warning”. Should one sensor deviate from the other two by 0.2 bar or more a Cell Warning will appear on the handset display, the Head up display will flash green and red together and the audible alarm will sound. From V05.01.00 firmware onwards a cell invalidation routine is added should a cell deviate to below 0.02 bar or to 2.55 bar +. Once a cell deviates to that extent, the ppO₂ display for that sensor is inverted and shows green on a black background. Once inverted you know that it will no longer be used for averaging and the machine operates on the other two cells. Should a 2nd cell deviate beyond those extremes (<0.02 & >2.55) then that cell will also be invalidated and the machine will operate on one cell. At each juncture the cell warning alarm will activate which will give you the opportunity to flush with diluent gas (or oxygen when shallower than 6m) which achieves two things: it gives you breathable gas instantly and allows you to compare the displayed ppO₂ with actual. Tip: The cell check feature in the Menu saves you doing the ppO₂ calculations.

3.5.5 Effect of Moisture on the Cells

In use the atmosphere in the scrubber is virtually always humid. When the scrubber lid is removed, after the dive, condensation and moisture will be evident. This cannot be avoided due to the moisture created by the Sofnolime reacting with and removing the CO₂ from the atmosphere in the loop. Humidity levels have been considered when determining the accuracy of the information provided to the diver, in the same way an allowance has been made for the effects of the inherent ± 1% accuracy of the cell outputs. The accuracy of the oxygen controller's reading is ± 0.05 bar, allowing for all normal use errors.

However, large drops of water either on the front cell face or in the back of the cell may affect the readings. Water on the cell's sensor face tends to slow down the reaction of the cell to changing ppO₂ and water in the back of the cell tends to push the ppO₂ read out higher. The cells used on the Inspiration, Evolution and Evolution+ have been modified to help eliminate both of these problems. When fitting replacements ensure only original parts are used. Ask for the APD12 oxygen cell for the VISION ELECTRONICS.

3.5.6 Setpoint Selection

On the Recreational 1 (17m) and Recreational 2 (40m) versions the setpoint is changed GRADUALLY and automatically for you, increasing as you descend and decreasing as you ascend. It changes in 0.1 bar increments between your high and low setpoint values, according to the table below:

On other version of software there are two setpoints. A low setpoint used when on the surface and for the descent and a high setpoint used when on the bottom and for most of the ascent. The switch from low to high and back again is either done manually with the centre switch on the display or done using the AUTO setpoint switch facility. On the ascent, if the diver has not reverted back to the low setpoint by the 100% O₂ depth (3m on a 1.3 bar setpoint, 2m on a 1.2 bar setpoint), the electronics will automatically revert back to the low setpoint, providing the AUTO option has been selected. Once selected it will stay on AUTO Setpoint switch (see Section 8.1.3, 8.1.4 for details).

The setpoints are user selectable to match the type of diving planned. However, begin by using the default values: a low setpoint of 0.70 bar and a high setpoint of 1.3 bar. With a ppO₂ in the loop of 1.3 bar, the maximum oxygen exposure is 3 hours per exposure or 3.5 hours per day, when using the NOAA oxygen toxicity limits.

The Absolute Pressure at the surface is approximately 1.0 bar, if a higher setpoint than this is selected whilst still at the surface, the unit will continually inject oxygen, trying to reach the setpoint. Since this cannot be achieved the result would be a waste of oxygen and battery power. Look out for this and make sure a low setpoint is selected when at the surface.

In your Nitrox training you will have learnt about CNS oxygen toxicity and the NOAA exposure limits. When selecting setpoints, be sure to consider the oxygen toxicity limits, see Table 3.

Table 3 NOAA - CNS oxygen toxicity exposure limits

ppO ₂ (bar)	Exposure Limit per Dive	Exposure Limit per Day (mins)
1.6	45	150 (2 ½ hours)
1.5	120 (2 hours)	180 (3 hours)
1.4	150 (2 ½ hours)	180 (3 hours)
1.3	180 (3 hours)	210 (3 ½ hours)
1.2	210 (3 ½ hours)	240 (4 hours)
1.1	240 (4 hours)	270 (4 ½ hours)
1.0	300 (5 hours)	300 (5 hours)
0.9	360 (6 hours)	360 (6 hours)
0.7	570 (9 ½ hours)	570 (9 ½ hours)

3.5.7 Pulmonary Oxygen Toxicity

Prolonged exposure to oxygen in excess of 0.5 bar can lead to pulmonary toxicity, affecting the whole body. Normally sport divers (on SCUBA) would never achieve such high exposures. However, with a rebreather such high levels may be achievable and it is necessary to ensure the limits are not exceeded. As a rough guide - if you stay within the NOAA CNS guidelines then pulmonary oxygen toxicity is only of concern during long duration dives over multiple days. e.g. 6 hours diving per day, every day, (using a ppO₂ of 0.9) for 14+ days. Check your dive times for risk of pulmonary oxygen toxicity by consulting one of the technical diving organisations' (IANTD, TDI or ANDI) workbooks. Using the higher ppO₂ levels of 1.35, 1.45 and 1.55 the CNS clock is the limiting factor in all cases.

The electronics OTU (Oxygen Tolerance Units) indicator is based on a daily maximum of 300 OTU per day but is displayed as a % of limit i.e. 50% = 150 OTU.

HYPEROXIC MYOPIA



WARNING! There have been instances of Myopia (near sight) occur as a result of diving, every day for 2 weeks on rebreathers. Some reports have indicated that corrective spectacles are required for three months. Some have reported a long-term shift to corrective lenses, while others have reported a return to normality within 2 weeks. Anecdotal evidence suggests 3 to 4 hours of diving per day for 14 days is sufficient to cause Myopia. Divers over the age of 40 seem to be more susceptible.

3.5.8 Oxygen Limits for Diving Operations

ppO ₂ LEVEL	EFFECT
0 - 0.10	COMA OR DEATH
0.10	Unconsciousness
0.12	Serious signs of Hypoxia
0.16	Minor signs of Hypoxia
0.21	Normal air environment at the surface
0.40	LOW OXYGEN warning
0.70	Default Low Setpoint
1.30	Default High Setpoint
1.40	Recommended recreation limit
1.60	HIGH OXYGEN warning

3.6 Duration of the CO₂ Scrubber

The CO₂ durations were determined using the DERA/QinetiQ unmanned test facility at Alverstoke. Test conditions: Water temp: 3 to 4°C, Breathing rate: 40 litre/minute, CO₂ rate: 1.6 litres/min. These rates have been previously determined by QinetiQ, as an average breathing rate, averaging out work and rest cycles.

3.6.1 Duration of the “Inspiration” and “Evolution+” 3 Hour CO₂ Scrubber

Rule No 1 - Dive Planning

The Sofnolime must be replaced after 3 hours of use for CO₂ produced at a rate of 1.6 lpm

Multiple Dives

The scrubber can be used for multiple dives, providing the Sofnolime is not soaked during a dive, **bearing in mind the total timed used must not exceed 3 hours** (for CO₂ produced at 1.6 lpm).

Effect of Depth

In trials, depth has proven to significantly reduce the scrubber’s CO₂ absorption capability.

Rule No 2 - For dives deeper than 20m, the diver must leave the bottom when the total time breathed from the unit reaches **140 minutes** (for CO₂ produced at 1.6 lpm). e.g. If dive 1 is for 100mins and the 2nd dive is deeper than 20m, the bottom time of the 2nd dive must not exceed 40 mins. Check the decompression times for the 2nd dive to ensure the dive durations, when added together, do not exceed 3 hours!

Rule No 3 - For dives deeper than 50m the diver must leave the bottom when the total time breathed from the unit reaches **100 minutes** (again this applies to CO₂ produced at 1.6 lpm.). e.g. If dive 1 is for 90mins and the 2nd dive is deeper than 50m, the bottom time of the 2nd dive must not exceed 10 mins. Check the decompression times for the 2nd dive to ensure the dive durations, when added together, do not exceed 3 hours!

3.6.2 Duration of the “Evolution” 2 Hour CO₂ Scrubber

Rule No 1 - Dive Planning

The Sofnolime must be replaced after 2 hours of use for CO₂ produced at a rate of 1.6 lpm

Multiple Dives

The EVOLUTION’S scrubber can be used for multiple dives, providing the Sofnolime is not soaked during a dive, **bearing in mind the total timed used must not exceed 2 hours** (for CO₂ produced at 1.6 lpm).

Effect of Depth

In trials, depth has proven to significantly reduce the scrubber’s CO₂ absorption capability.

For dives doing the entire decompression on the EVOLUTION – the dive must be planned to exit the water at or less than a total runtime of 2 hours.

Rule No 2

For dives where the EVOLUTION is used only for the bottom portion of the dive and alternative sources of decompression gasses are provided, the bottom time (time of leaving the surface to time of leaving the bottom i.e. runtime) must not exceed 55 mins at 60 to 100m.



WARNING!

1. This information is based on using the 1.0 - 2.5 mm diving grade Sofnolime and tested using a water temperature of 4°C and an average CO₂ production rate of 1.6 litres per minute.
2. Some people produce more than 1.6 litres per minute of CO₂ and usage times must be shortened. Conduct personal oxygen consumption trials at work and rest to determine your own CO₂ production before use. Calculate your approximate CO₂ production by multiplying your oxygen consumption by 0.9 .
3. Never expect the Sofnolime to last longer because you are in warmer water but do expect it to last for a shorter period if used in colder temperatures than 4 °C.
4. The design of the scrubber, not just the weight of Sofnolime, is a major factor in the duration, so these performance figures cannot be used for determining the duration of another make of scrubber.
5. If other scrubber materials are used, such as 2.5 - 5.0mm Sofnolime, then these duration figures are invalid.
6. The performance of the scrubber was tested at the QinetiQ test centre on a fresh batch of material, taken straight from the manufacturer’s packaging.
7. Material that has been left exposed to the atmosphere can appear to be satisfactory but in reality may only work for a short period.
8. The efficiency of the material may vary slightly from batch to batch.
9. The information given applies to Air, Trimix (with a max. END of 30m at 70m, reducing to an END of 24m at 100m) and Heliox diluents.

3.6.3 How do I know when the CO₂ absorbent can no longer absorb CO₂?

If fresh Sofnolime of the correct grade is used, then the time used can be recorded and compared to the three rules above. Recording the time used is most important! This is the only practical way of predicting the remaining absorbent life. The Temp-Stik Scrubber monitor, if fitted, shows the diver the active area of the scrubber according to the dive conditions/work rate during the dive, not before the dive!

The rebreather with VISION Electronics is fitted, optionally, with a patented Temp-Stik and CO₂ scrubber monitor. This does not measure or sense CO₂, it monitors the warm areas of the scrubber giving a graphical indication to the diver of the active area of the scrubber bed. This is then compared to test data, and warnings are then generated in the display and HUDs. In this manner advance warnings can be given which are work, depth and water temperature related.



Warning DO NOT RELY ON COLOUR CHANGE

Some Sofnolime changes colour as it is used but this is only a guide as the material returns to the natural colour after a time and is also temperature dependent.

Replace the Sofnolime if the material is soaked; do not attempt to dry it out.

3.6.4 Extra CO₂ Considerations

If you intend to use the absorbent for subsequent dives, leave the absorbent in the scrubber and seal it using the convoluted hoses. **Do not remove and repack partially used absorbent, as CO₂ breakthrough will occur much earlier than expected.** When absorbent is removed from the CO₂ cartridge, dispose of it immediately.

The CO₂ cartridge is easily refilled by the diver. The normal weight of Sofnolime required is 2.45 kg of 1 - 2.5mm (8-12 mesh) granule size, 797 diving grade, Sofnolime.

Some settling of Sofnolime will occur. A small amount of settling will be taken up by the spring loaded base plate. Care must be taken if a long journey is undertaken between packing the cartridge and diving with it. Always inspect the cartridge before the dive.



Warning Hypercapnia, an excess of CO₂ at cellular level, can become a problem in any form

of closed circuit rebreather diving. Reduced efficiency of the absorbent, channelling of breathing gas through the absorbent due to poor packing of the absorbent during refill or if the absorbent becomes wet, can lead to increased CO₂ levels which can result in Hypercapnia. Other possible causes include damaged or misplaced scrubber components or inverted non-return valves in the mouthpiece. Be aware of an increased breathing rate, symptoms of confusion. If you don't remove yourself from the breathing circuit to an open circuit bail out, for instance, the following symptoms or signs will ensue very quickly: severe tremors, loss of balance, dissociation or unconsciousness.



Warning Early CO₂ warnings, such as respiratory distress, are often not detected when breathing

oxygen at pressures higher than 0.21 bar and in particular, rebreathing CO₂ in 1.0 to 1.3 bar of oxygen is known to offer virtually no physical warning to the diver and escalate quickly to severe tremors and unconsciousness! - a good reason to remain within the scrubber times stated earlier, to do proper pre-breathes and to not dive alone.

Maintenance of the apparatus, including disassembly of the scrubber, is detailed in Section 13.

3.7 Symptoms Associated with Low and High Oxygen Levels, High CO₂ Levels and Oxygen Toxicity

The following is intended to be a brief overview. For further information we recommend studying the IANTD, or similar, training organisation manuals.

Hypoxia Symptoms (Lack of oxygen)

Hypoxia is extremely dangerous and is potentially fatal. The warning signs are very slight and hardly noticeable. Once the ppO₂ drops below 0.1 bar, the diver will become unconscious. It is, therefore, essential to monitor the oxygen controller at all times. Oxygen should be administered to a victim as soon as possible but may not always be successful.

Hyperoxia Symptoms (excess ppO₂)

Spastic Convulsions are not always preceded by warning symptoms. It is, therefore, essential to monitor the oxygen controller at all times.

Central Nervous System (CNS) Oxygen Toxicity Symptoms:

Visual problems (focus, tunnel, spotty etc.)

Ears (ringing, abnormal)

Nausea (spastic vomiting)

Twitching (facial)

Irritability

Dizziness

Whole Body Oxygen Toxicity Symptoms:

Dry cough

Shortness of breath

Increased breathing resistance

Discomfort in chest

Hypercapnia Symptoms (excess CO₂)

CO₂ convulsions are easily confused with oxygen convulsions and in an elevated ppO₂ (above 0.21 bar) convulsions and unconsciousness are rarely preceded by warning symptoms. It is therefore essential to change the Sofnolime regularly and ensure correct assembly and operation of components such as scrubber cartridge O ring, spacer and mouthpiece non-return valves.

Rare warning signs

Shortness of breath *

Headache *

Dizziness *

Onset of these symptoms can occur very quickly and without warning:

Severe Tremors

Loss of Balance

Dissociation

Unconsciousness



* **Warning:** The first CO₂ symptoms are not always evident when breathing oxygen above 0.21 bar. Wartime testing by the British Admiralty's Experimental Diving Unit proved that oxygen breathed at 1.0 bar whilst exhaled CO₂ was rebreathed, resulted in severe respiratory distress in only 3 out of 18

tested. The remaining 15 subjects suffered acute nervous symptoms or signs i.e. severe tremors with loss of balance, dissociation & unconsciousness. These all occurred between 200 and 380 secs from commencement. Don't take risks with CO₂!!!

SECTION 4

4.0 APPARATUS COMPONENTS

4.1 Inspiration Vision, Evolution and Evolution+ Schematic

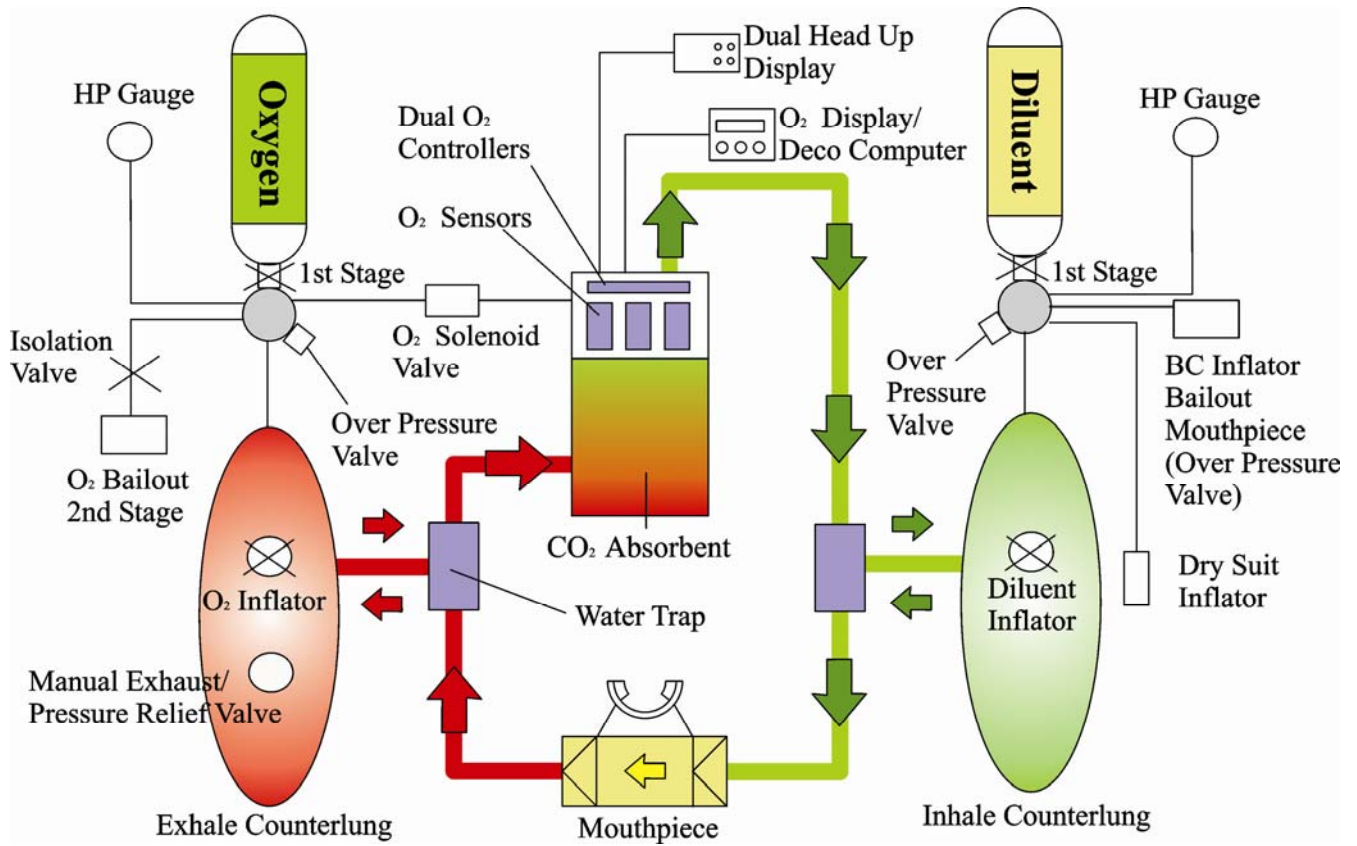

4.2 Counterlungs

Three sizes of counterlungs are available: medium, large and extra large. All have sufficient volume for breathing.

Select the breathing bags/counterlungs according to your body size. When wearing trousers with a belt and a T-shirt measure from the lower edge of the belt at the front over your shoulder and down to the lower edge of your belt at the back. Take the measurement on inhale:

Under 110cm - Medium Counterlungs

Over 110cm - Large Counterlungs

Over 125cm – XL Counterlungs

This is only a rough guide. For further advice please contact the factory, stating your height, chest and waist measurements.

It is essential to keep the counterlungs down on your shoulders to avoid excessive hydrostatic imbalance. They are prevented from floating upwards by the Fastex buckle located on the lower edge of each counterlung. These can be fastened to the special connection points on the Harness. If these do not allow the counterlungs to remain on the shoulders then either a smaller breathing bag, or the use of crotch straps, must be considered.

The optional rear mounted counterlungs are available in one size. In order to fit different body sizes it's position can be adjusted vertically by using the alternative mounting holes. It is essential to keep the counterlungs against your back and upper rear shoulder to avoid excessive hydrostatic imbalance.

4.3 Over-Pressure Exhaust Valve

This is a two-position valve with an additional manual override. In both the fully open (dive) and fully closed (pre-dive) positions there is a mechanical stop and “click” lock. Fully closed (clockwise) is the high-pressure setting, used for detecting leaks on the system and for providing positive buoyancy when at the surface with the mouthpiece closed. Fully open (anticlockwise) is the low-pressure setting, used throughout the dive. On this setting the loop pressure is kept below the maximum lung overpressure of 40 mbar. During the ascent, this setting may be too high for comfortable exhalation so the valve has a pull cord exhaust fitted which can be either operated intermittently or continuously during the ascent. The latter option has the advantage of keeping the breathing loop volume at a minimum eliminating the possibility of the expanding gas in the loop from adversely increasing the buoyancy. The other alternative is to exhale around the outside of the mouthpiece during the ascent or to breathe out through your nose. If this hands free approach is preferred then it is best to exhale around the outside of the mouthpiece as this exhausts gas from your lungs and the counterlungs simultaneously. It is essential to keep the counterlungs down on the shoulders to prevent the over-pressure valve operating continuously.

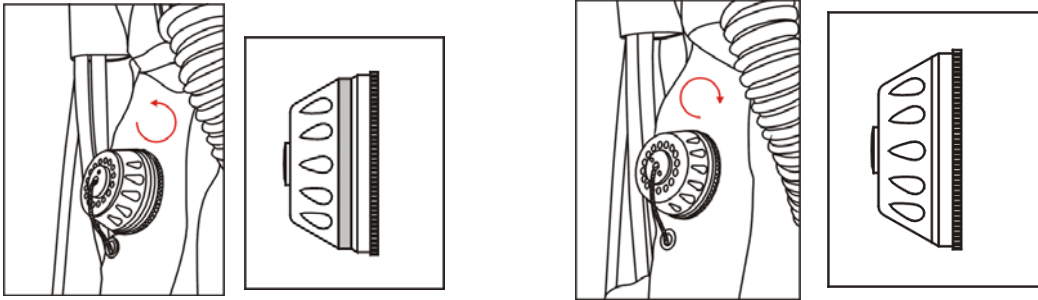

Low Pressure Setting - DIVE High Pressure Setting: PRE-DIVE for leak testing

4.4 Mouthpiece Valve

If the mouthpiece is removed while in the water, either underneath or at the surface, water may enter the loop. The rebreather is tolerant of small quantities of water entering but excessive quantities should be avoided by closing the mouthpiece before removing it from the mouth. When re-inserting into the mouth, blow out to remove the water from the water vent and, while continuing to blow, open the mouthpiece valve. The opening and closing of this valve is very important and must be practised on the surface prior to diving. Unlike any other mouthpiece on the market, the central body section rotates and moves independently of the two outer sections which move together with the inner tube of the mouthpiece valve. It is easier to hold the mouthpiece still, as this is often in your mouth, and rotate the outer rings. They are prevented from unscrewing by the two cross-head screws located underneath. When servicing, do not attempt to unscrew the outer sections without first removing the screws. Attempting to do so may damage some components.

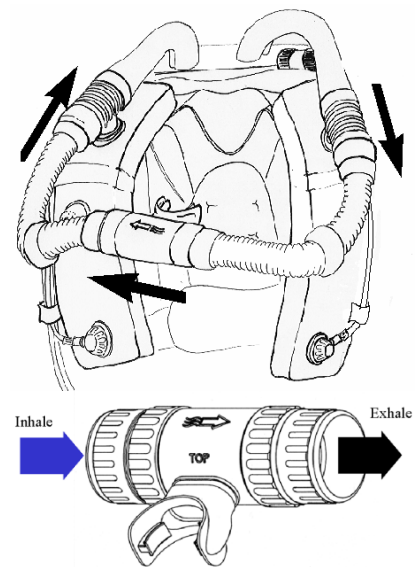

Located at each end of the inner tube is a non-return valve. These are keyed to prevent incorrect assembly. However, it is essential to check the direction of gas flow and check the proper operation of the non-return valves prior to using the rebreather. This can be easily carried out by disconnecting the hose connectors from the T piece and gently blowing and sucking against the connector. The direction of gas flow for the rebreather is clockwise when looking down on the unit. i.e. you exhale over your right shoulder. Therefore, when blowing into the right hand side hose connector the non return valve will close and it should open when air is sucked from the connector. The non return valve on the other end of the mouthpiece inner tube should close when air is sucked from the left hand connector and open when air is blown into the connector. After reassembling the hose to the unit check for correct operation by alternately squeezing the inhale and exhale tubes as you inhale and exhale. Gas must come from the left and go out to the right. You must not be able to inhale gas from the exhale side and exhale gas into the inhale tube.

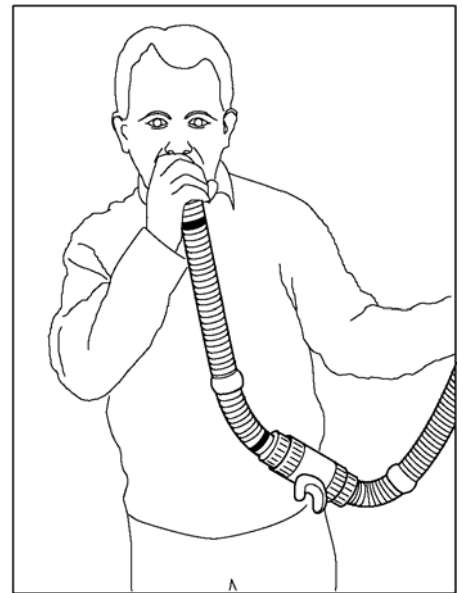

A mouthpiece with rubber head strap can be fitted to the mouthpiece valve assembly. The head strap offers additional support by holding the mouthpiece towards the wearer. The strap is particularly useful on long duration dives by minimising the effort needed to retain the mouthpiece in position, thereby reducing jaw fatigue. A head strap may also help retain the position of the mouthpiece if the diver becomes unconscious.



Warning Although the head strap offers some degree of support to the wearer, there can be no guarantee that it will hold the mouthpiece in the mouth of an unconscious diver.

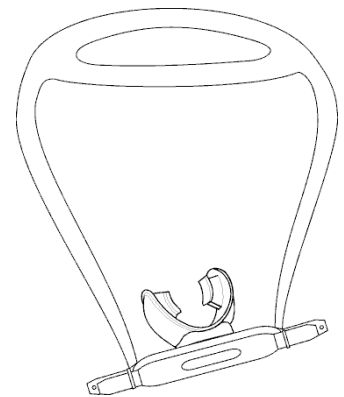

Warning If a head strap is used the diver must consider its consequences as it could hinder certain operations while in use i.e. draining water from the mouthpiece assembly and bailout drills, both of which may require the wearer to move the mouthpiece away from the face. As with any change to equipment configuration, relevant drills should be reviewed and practiced before diving with it.

4.5 Breathing Hose Connectors

The hose nuts are simply unscrewed. The connections to the scrubber and the T-pieces are piston type seals and seal even when slightly loose. These connections should be hand tightened onto the shoulder to prevent accidental unscrewing. Ensure the O-rings are lightly lubricated and not damaged before re-assembly.

Each hose nut is fastened to the convoluted hose using screw on connectors. These are larger versions of the connectors used to clamp the convoluted flexible rubber hose on the range of BUDDY Buoyancy Compensators. They allow easy removal for maintenance, they allow the hose to swivel at these joints and they provide an extremely secure connection.

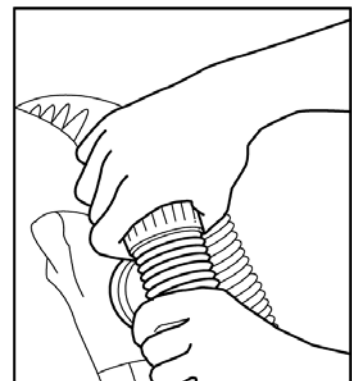

Convolved Hose pre 20th March 2009:

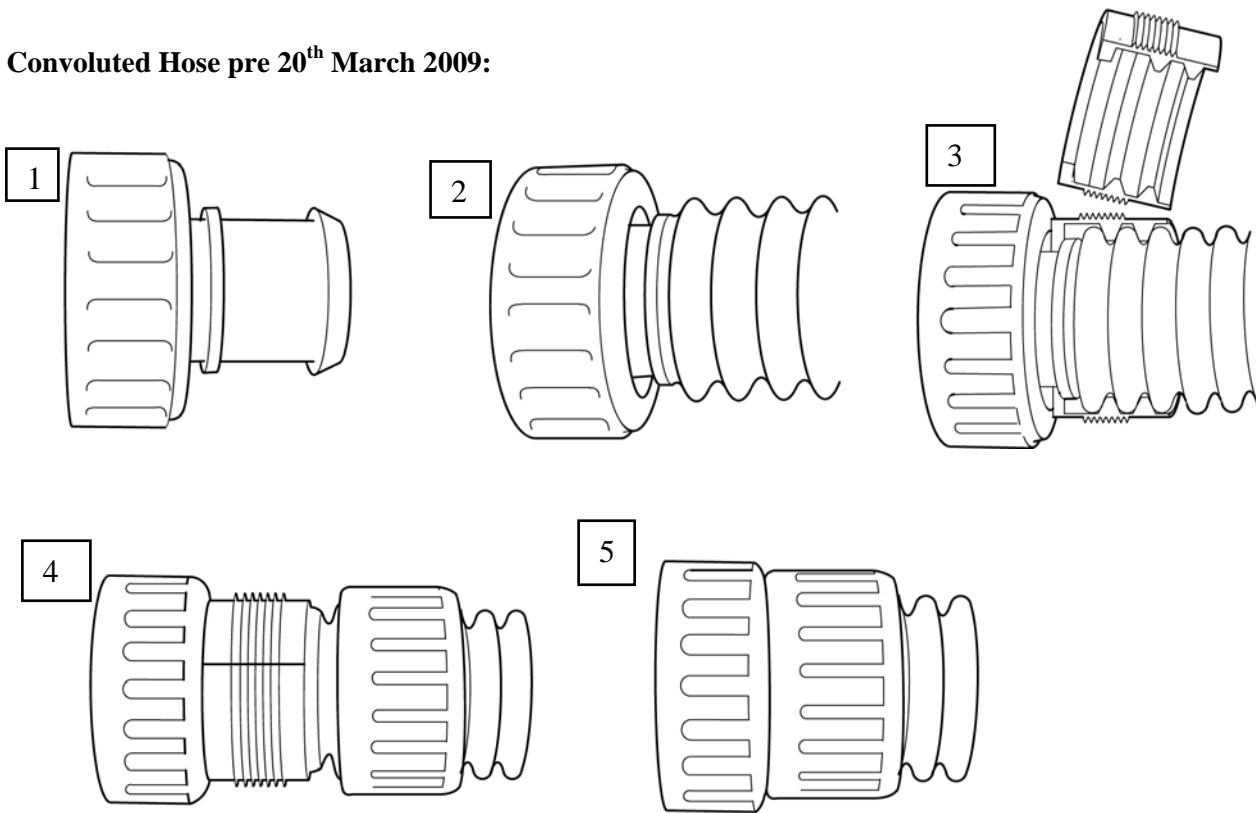

After the 20th March 2009 the fittings were changed to a pull off/push on hose collar. Sliding this back reveals a special cable-tie with a curved underside to aid sealing on the round fittings. Only original cable-ties should be used, tightened up with the appropriate cable-tie gun.

4.6 Colour Coding of Convolved Hose Connections

The blue rings all signify fresh oxygenated gas from the scrubber. The left shoulder T- piece located on the inhale counterlung has blue identification rings, as do the hoses connecting to it and the connection in the centre of the scrubber lid. The non-return valve in the inhalation side of the mouthpiece is also coloured blue.

4.7 Diluent and Oxygen Inflators

All inflators, oxygen, diluent and Buoyancy Compensator, are low-pressure balanced inflators, sometimes referred to as medium pressure inflators. They are designed to work with a maximum feed pressure of 15 bar. See the First Stage Interstage Pressures, Section 13.3. The inflator hoses connect to the low-pressure ports on the first stages.

It is essential not to confuse the oxygen components with their diluent counterparts. See Section 13.7, Precautions When Using High Pressure Oxygen. Both the diluent and oxygen systems must be checked for leaks prior to the dive and this is best done by dipping the valve in a water bath.

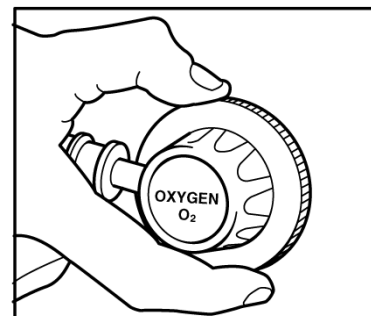

The oxygen inflator has special lubrication and seals and has undergone special cleaning to make it suitable for use with oxygen. It must only be connected to a hose supplying oxygen. As the apparatus is worn the oxygen inflator must be on the Diver's right hand, on the exhale counterlung and the diluent inflator must be on Diver's the left hand, on the inhale counterlung.

Both inflators are secured into a base fitting with a large, hand tight, moulded ring. By unscrewing this ring slightly the inflator can be rotated to best align the feed hose. After any adjustment, tighten the outer ring.

By unscrewing the outer ring completely the inflator valve can be removed. Care must be taken when removing it, as there is a large O-ring seal underneath it. Removing the inflator reveals a very useful drain valve which should be used after every dive to drain any water that has entered the counterlungs. This port can also be used to help with washing and disinfecting the inner bags of the counterlungs.

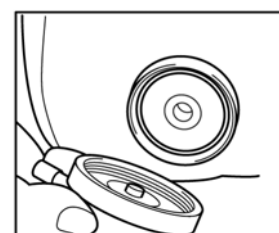

The optional rear mounted counterlungs use the low pressure, hose mounted, balanced inflators RBV05 (diluent) and RBV05A (oxygen), where the gas from the standard quick disconnect hose is fed back to the counterlungs via another LP hose.

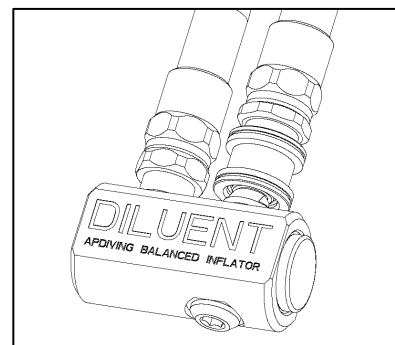

The connection port on the counterlung can be unscrewed for rinsing out the counterlung. Please take care not to lose the O ring and be sure to refasten securely.

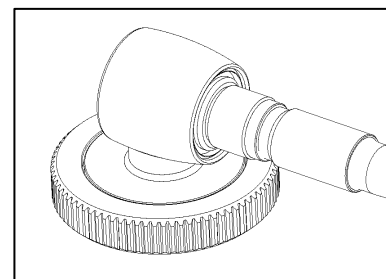

4.8 Automatic Diluent Valve (ADV)

The ADV is an optional feature. It replaces the inhale T-piece on the left shoulder counterlung and is usually fitted with the diaphragm facing the diver's head. The ADV is activated by a pressure differential across the diaphragm and it supplies gas to the loop (breathing circuit) whenever a substantial negative pressure is experienced within the inhale counterlung.

The gas supply hose connects with a 3/8"UNF thread to the low pressure port on a first stage or into the diluent portion of the manifold and connects to the ADV's 300° swivel. The swivel allows for the hose to be fed from the rear e.g. from the manifold, or from the front, from a side mounted diluent cylinder. If the side mounted cylinder needs to be removed in water the optional in-water quick release connector is available. The ADV is an upstream valve and can be used with 1st stages delivering 7 to 11 bar (nominal 9.5 bar) above ambient and requires no adjustment. The elastomeric diaphragm cover allows manual operation.

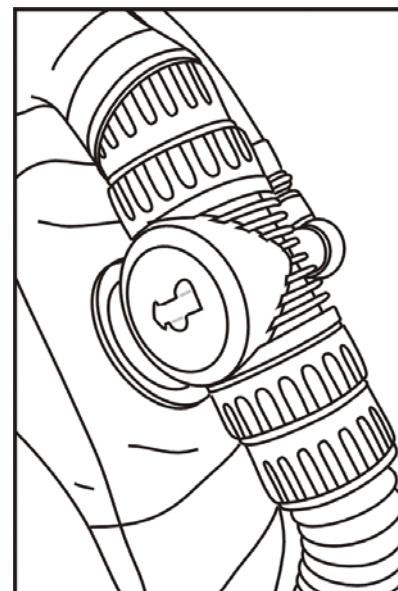

During descents it is normal for the ADV to add gas on nearly every inhalation. However, this is most abnormal during all other phases of the dive. Normally the ADV adds gas to make the counterlung volume breathable and then stops.



WARNING: If the ADV operates on every inhalation this is an indication of either poor rebreather diving practice like exhaling through the nose or is a sign of some other leak from the loop. Any extra diluent addition usually has the effect of reducing the ppO_2 within the breathing circuit and would be countered by the oxygen controller adding oxygen to regain the setpoint. The danger of inadvertently using excess gas from both diluent and oxygen cylinders is higher when using an ADV and extra monitoring of cylinder contents gauges should take place.

Located on the left shoulder, rolling left side down may force the ADV to add gas to the loop as will rotating head down, when the gas in the counterlungs migrates upwards away from the ADV and causes a negative pressure on the inside of the diaphragm. Whenever these manoeuvres are undertaken you may need to run the counterlungs with a higher gas volume than normal.

4.9 Weight Pockets

If you lay still in a horizontal position on open circuit and fully inflate your lungs you will notice that you are brought into an upright position. This is exactly what happens on a rebreather. As we breathe in and out of the counterlungs, the buoyancy at the chest area is constant which means you may find that you are constantly being brought into an upright position. To counteract this effect, lead has to be moved from your waist area to the top of the unit. It can be inserted into the weight pocket on the top of the rebreather, attached to the top of the rebreather with ty-raps or placed in the trim weight pockets in the wings. Normally, removing 2-3 kg from your weight belt and putting it at the top of the unit is sufficient. It is worth spending time getting this right. You will be surprised how many divers don't take the time – you will see them having difficulty swimming horizontally.

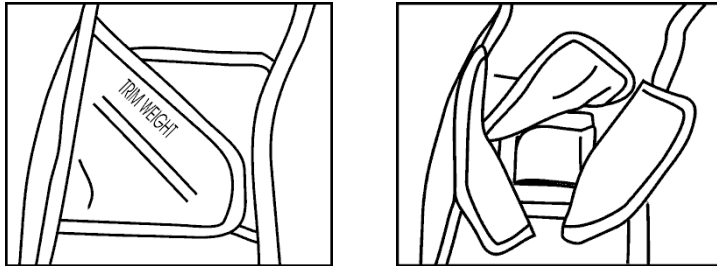

4.10 Buoyancy Compensator and Harness

A Buoyancy Compensator must be used with this rebreather. Do not use the counterlungs to control your buoyancy.

A 16kg wing has been specially developed for use with the rebreather, in conjunction with the harness. 25mm Fastex buckles are located low down at the front, which are used to hold the counterlungs down on the diver's shoulders. Holding the counterlungs down is extremely important and care must always be taken to ensure they are not allowed to float above your shoulders. If this happens; breathing resistance will increase dramatically, probably causing some discomfort - if not immediately, certainly after a time. Increased breathing resistance means increased CO₂ retention, which is believed to make the diver more susceptible to oxygen toxicity and nitrogen narcosis. If the counterlungs are floating off the shoulders, ensure the waistband of the harness is not riding up. Simply adjusting the waistband usually cures this. If it cannot be secured, you may have to add a crotch strap, one is provided with each rebreather, or it may be necessary to change to a smaller size counterlung.

Weights pockets are incorporated in the harness and BC jacket option. Using these will most likely increase diver comfort and reduce any back pains which can occur if the diver uses a separate weight belt.

4.11 Auto Air

The Auto Air is fitted as standard to the buoyancy compensator. It is a multi-function valve, not only is it the BC inflator, it can also be used for BC deflation as well as emergency breathing from the on-board diluent cylinder. Most importantly the Auto Air is also a pressure relief valve. Should the 1st stage leak, the rise in intermediate pressure will automatically be relieved through the Auto Air.

Note: normally, diluent is not used during the ascent. This means that the intermediate pressure increases in relation to the ambient pressure as the diver ascends. The Auto Air will bleed off this excess pressure automatically. It may appear that the Auto Air is leaking but all it is doing is relieving the excess intermediate pressure. A simple purge is all that is needed to stop the gas dribbling out or it can be simply left alone.



WARNING: if the Auto Air is replaced with a conventional inflator and a conventional 2nd stage, be sure to fit a downstream 2nd stage. If an upstream 2nd stage is fitted or a flow control device such as the AP "Flowstop" is used then be sure to fit an additional pressure relief valve to the intermediate pressure. The RB17 (14bar) is an example of a suitable automatic pressure relief valve and since 2001 is fitted as standard on every diluent 1st stage supplied by APD.

4.12 Audible Warning Device

The audible warning device or buzzer is located on the left shoulder and is directed towards the divers head. This is only a secondary device; the primary warning device being the ppO₂ displays, and is not to be used as the diver's only warning system. All audible warnings continue while the fault is occurring unless it has been suppressed by the diver. High-level warnings (e.g. High O₂ and Low O₂) are not suppressible.

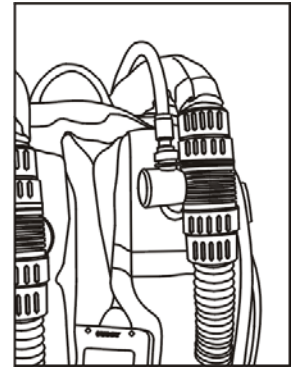

4.13 Oxygen Solenoid

In DIVE mode the oxygen solenoid is activated ONLY when the ppO₂ is below the setpoint. The oxygen solenoid is opened for a variable time, from 0.2 secs to fully open, depending on how far the ppO₂ is below the setpoint. Larger pressure drops, such as during the ascent, prompt longer solenoid opening times to regain steady state setpoint as soon as possible. This variable open time is then always followed by a 3 second close period, hence a slight delay (up to 3 secs) may be noticed before expected solenoid activity but this is quite normal.

The latest oxygen solenoid valve (EV06/01/12) has been specifically designed to APD specifications regarding material, responsiveness, flow rate, operating pressures and power consumption. The advantages of the latest solenoid are:

- Much lower power consumption - half of the original - resulting in significantly longer battery life. Nominal consumption = 0.6Watts
- Works with a wider range of supply pressures
- Operates to lower voltages than the original
- Simple design

4.14 Head Up Displays

Four LEDs (light emitting diodes) are located in the scrubber lid. Two LEDs (one red, one green) are driven by Controller 1 and two LEDs (one red, one green) are driven by Controller 2. The light from the LEDs is then "piped" via four solid, flexible polyethylene, fibre optic rods to an eyepiece. The eyepiece fits into a special holder on the mouthpiece. These "lights" are much closer to the eye than most adults can focus. This is done intentionally, the lights are kept in the peripheral vision and the "blurring" makes the lights appear larger than the pinhead light source of each fibre optic rod.



Note: It is essential for the diver to ensure that all four lights are visible (when shallow, add air to the loop to activate the red lights). Due to different mask frames and head shapes some alterations may be needed: The diver should consider purchasing an alternative mask if necessary, the new generation frameless masks are one option. Sometimes, it may be necessary to adjust the position of the hose weights so the mouthpiece floats at the correct height. Be sure to adjust the mouthpiece to a horizontal position by rotating the inhale and exhale hoses at the T-piece swivels, ensuring the hoses are not kinked. Adjust the HUD position and orientation as necessary.

4.15 Scrubber Monitor (optional)

The central rod of the scrubber is replaced by the 'Temp-Stik'; a similar rod with internal temperature sensors, connected by a cable. This is a plug and play device. Inside the scrubber lid is a spare connector: connecting this to the corresponding connector on the temperature stick activates the software so the scrubber monitor is shown in the top centre of the wrist-mounted display.



WARNING! This system does not measure CO₂. It simply measures the temperature in the scrubber material at levels through the bed of Sofnolime. It therefore does not warn the diver if there is no Sofnolime present. It does not warn the diver when CO₂ bypasses the Sofnolime cartridge due to for example a missing or damaged O-ring. It does not warn the diver of CO₂ coming via damaged or missing mouthpiece non-return valves. IT DOES NOT DETECT CO₂.

4.15.1 Scrubber monitor Display

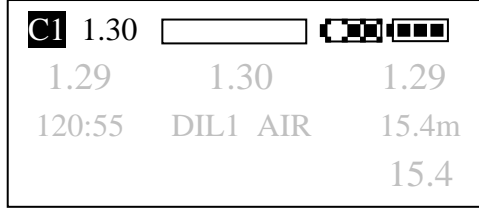
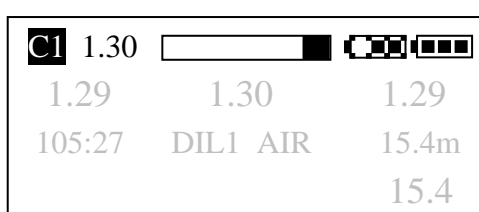
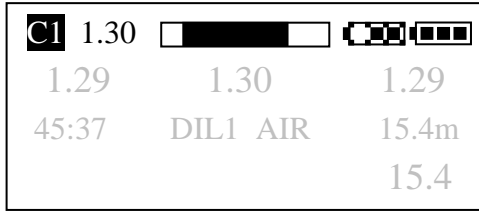
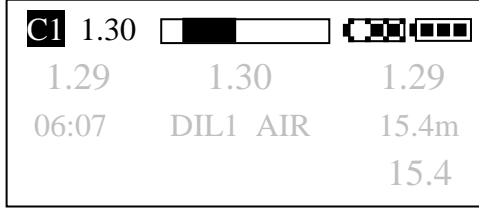
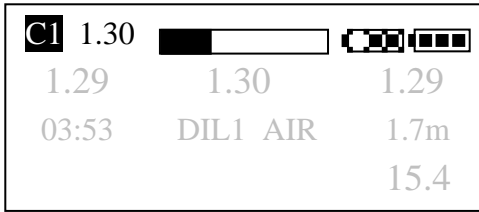
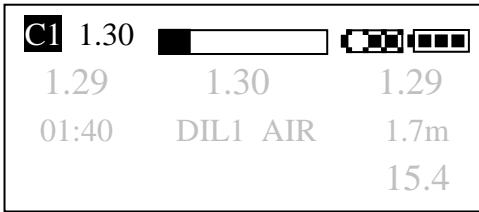
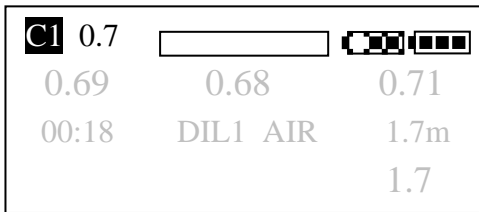

The scrubber monitor simply shows the active part of the scrubber. The gauge starts out empty and as the bottom of the scrubber warms up, the display on the left side of the scrubber display turns black, followed by the next segment and so on progressing across the scrubber monitor from left to right.

The Sofnolime at the bottom of the scrubber is soon used and starts to cool down. This is reflected in the gauge by the left side of the gauge display clearing.

As the Sofnolime further up the scrubber warms up the display in those areas go black and the active area of the scrubber is seen to move from left to right across the gauge.

Towards the end of the scrubber activity the software changes the display so the scrubber monitor works more like the fuel gauge on a car. i.e. when the gauge is empty you cannot stay on the rebreather and open circuit bailout should be used.



WARNING! This system indicates the activity of the scrubber throughout the dive, it is not an indication of the scrubber time available for a subsequent dive. This system offers no prediction of scrubber life remaining as this relies on several unknown factors: e.g. your future work rate, the depth to which you intend to dive, the water-temperature you intend to dive in, but if you do enter the water, all these factors will be automatically considered as they occur i.e. if you start working harder the scrubber monitor will reflect this by filling and emptying the gauge display faster.



WARNING! When the display shows one black segment on the right side of the gauge a “Scrubber Warning” is given. This is suppressible but the dive should be aborted. When the display clears the scrubber is used and an alarm is sounded and displayed on both the HUDs and wrist display. This warning is not suppressible. If you proceed past this indication CO₂ symptoms, which could prove fatal, may be incurred without physical warning.

4.15.2 Subsequent dives

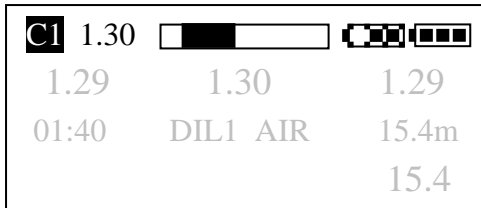

If the scrubber is used for another dive, the bottom of the scrubber rarely heats up, indicated by the clear left hand side of the scrubber monitor.

4.15.3 Tracking

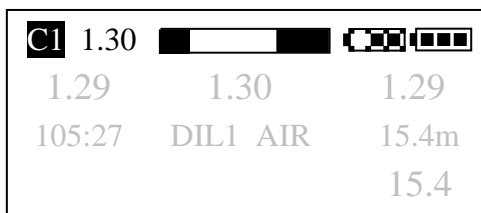

Should CO₂ start tracking through the scrubber this is indicated by the clear section(s) being shown between black “active” portions of the scrubber. **Abandon the dive immediately and re-pack the scrubber with fresh material.**

4.16 Case Mounted Cylinder Clamp (optional)

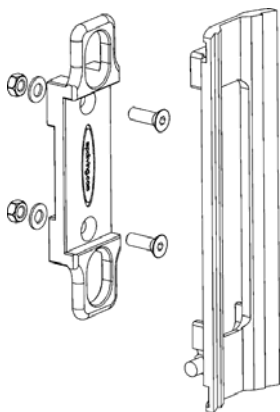

Ideal for attaching cylinders securely and conveniently to the side of the case. It features a strong and easy to operate quick release/attach mechanism. The case-plate is bolted through pre-drilled holes in the case. The cylinder plate, incorporating the quick release/attach mechanism attaches to the cylinder with rubber sleeved “jubilee” clamps (not shown). The case-plate is compatible with the range of Metalsub diving lamps and accessories.

4.17 Display strap

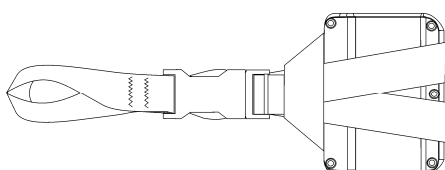

Normally the display is mounted on the diver’s wrist retained by the two wrist straps. Alternatively, a display strap can be used to suspend the display, attached to a suitable D ring with a quick release buckle.

SECTION 5

5.0 POWER ON

Note: The VISION electronics, are available in German, Dutch, Italian, Spanish, Portuguese, French, Danish, Czechoslovakian and English.

5.1 General

The electronics consist of 2 Oxygen Controllers (C1 and C2), located in the scrubber lid, each with its own battery and intelligent Head Up Displays (HUD). Connected to both O₂ controllers is a wrist mounted, dual strap, display incorporating 3 switches for operational control. These switches will be referred to as Left, Centre and Right when looking at the display. Each O₂ controller is independent of the other, each has its own battery and each controller alone can completely support all life support system functions. The second control module provides for total redundancy in the life support functions and both modules will continue to operate without the wrist-mounted display. Also connected directly to each controller are, 3 oxygen sensors, 1 audible alarm, 1 oxygen solenoid and two x 2 LED head up displays (HUD) mounted near the mouthpiece.

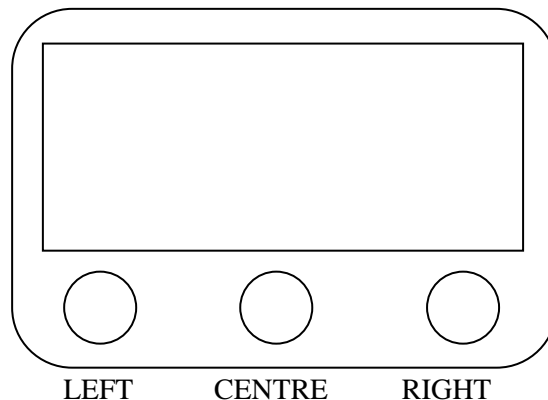

WARNING! If the diver does not switch the electronics on – the electronics will NOT control the oxygen pressure within the breathing circuit which will lead to unconsciousness and death if the diver continues to breathe from the rebreather.



WARNING! There are NO wet contacts for automatic operation when the diver enters the water the diver has to take responsibility for turning on the electronics AND opening both the oxygen and diluent cylinder valves.



WARNING! It is the diver's responsibility to ensure all systems are functional prior to and during the dive.

Note: When first switched on the electronics perform self-tests. However, if the pressure sensor detects a pressure equivalent to a depth approx. greater than 1.2m (4 ft), the self-tests will be skipped. This importantly allows the rebreather to be re-started if switched off underwater, even if faults exist.

Note: When you first switch the electronics on and before you go into “dive mode”, it will try to maintain a setpoint of 0.21bar and the low oxygen warning will be at 0.16 bar. This is to attempt to keep those alive who breathe from the loop without progressing far enough through the start up sequence and warn them. It is not fool proof. If the oxygen isn't turned on and the diver ignores the warnings.... unconsciousness, followed by death will ensue, unless effective rescue is at hand.

5.2 Switch On

Note: The three switches are maintenance free, no movement switches – they operate under all normal temperature and pressure conditions. For successful manual operations on land or underwater, push the switches GENTLY with the soft pad of your finger, NOT the hard tip. These switches work extremely well with thick Neoprene gloves. If you have pressed the switch correctly an “indicator line” appears in the display, just above the switch. Many functions such as changing gas mix or time settings involve scrolling which is easily achieved by pressing and holding. Should the “indicator line” not be on, the option is not chosen and pressure should be released and re-applied. Pressing the switch hard does not improve the switches function and may damage the switch.



Warning: Hard objects must not be used to operate the switches.

Switch On – Press left hand switch on handset and hold for 1 second.

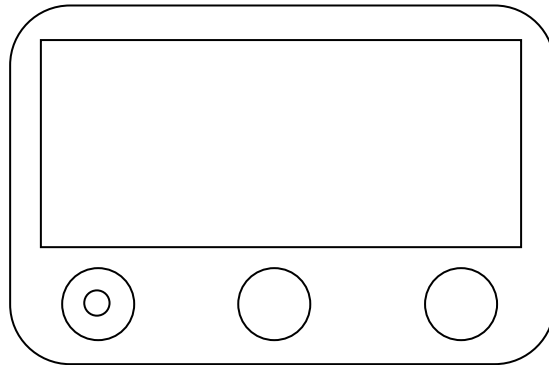

The two controllers perform their self tests. C1 performs its test first and if the connection to the display is operational the display backlight will come on and the start up splash screen is displayed.

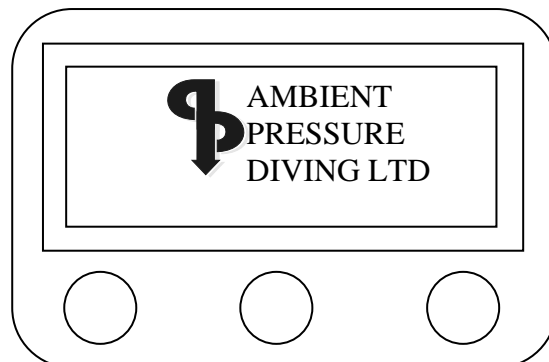

The HUD will flash both LEDS for C1 twice in 1 second in sync with the buzzer, repeated by controller C2 and then the LEDS will go out, until in Dive Mode.

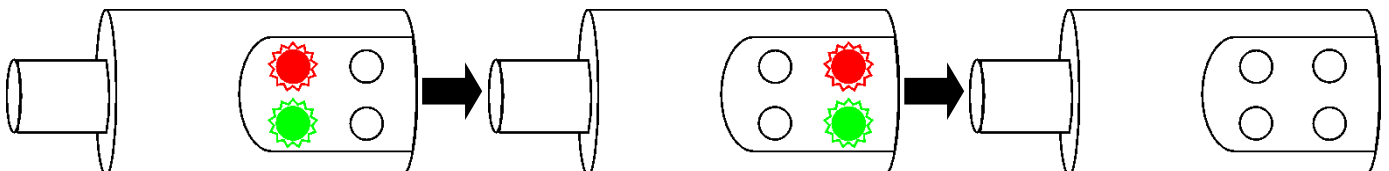

If only C1 is powered there is a short delay of about 1 second before the splash screen is shown on the display.

5.3 Software (Code) Version

The version of the wrist mounted display code is shown on the 2nd line. In this example version 05.01.00 is the installed code. From time to time, new code will be released. The latest code may be downloaded over the internet to your PC and uploaded to the electronics, www.apdiving.com. The status of the decompression program is shown in this example as the Trimix version. Alternatively, this would be Dive Timer or Nitrox depending on whether you owned the dive-timer version or the Nitrox version.

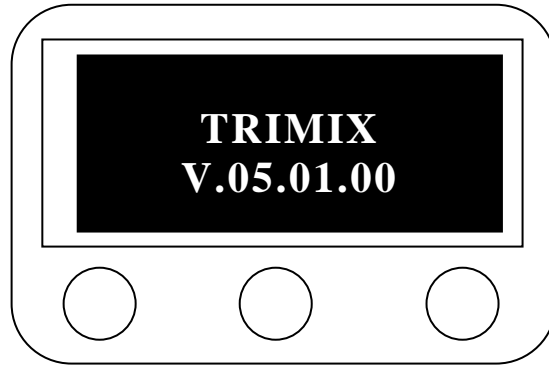

Note: The displayed version number is only for the wrist-mounted display code. Encapsulated in the lid of the scrubber are the two oxygen controllers which will most certainly have different release code Nos. To see these Nos. click on the top bar of the main screen of the APD Communicator program, when all three controllers' details will be revealed.

5.4 Owner's Registration Screen

The Registration screen is programmed by the factory and may be changed by the user for second or third owners. The Serial No. is shown on the bottom line. To change the data an upload file needs to be sent from the factory, info@apdiving.com.

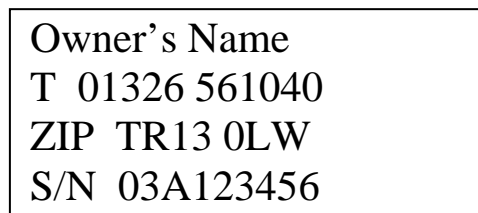

5.5 Electronics Self-Test

An automatic self-test is performed and the results for Controllers 1 and 2 (C1 & C2) are displayed. A tick is displayed if the device is detected; a cross is displayed if the device is not detected.

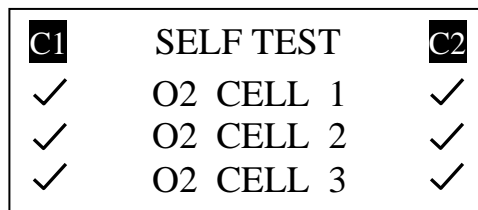

There is a spare, unused, self-test slot on the 2nd self-test screen.

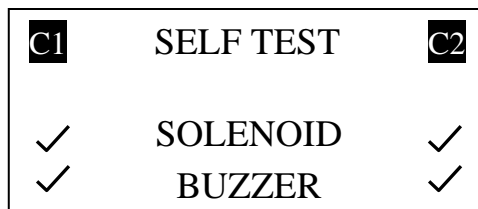

5.6 Temp-Stick Test

If the Temp-stick is detected a row of ticks are displayed. If the Temp-stick is not detected crosses are displayed.

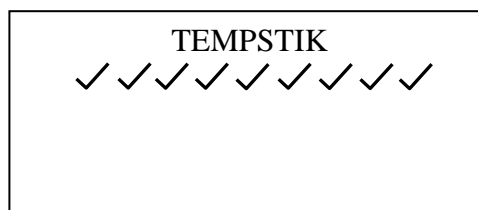

5.7 Failed Solenoid or Oxygen Cell Self-Test

For a dive to take place, the oxygen cells and solenoid must be seen by one of the controllers. Missing LEDs and buzzer will result in a user warning only, but will not prevent the dive proceeding. If both LEDs and buzzer are missing, extreme vigilance must be exercised as the ONLY warnings will appear on the handset.

One oxygen cell NOT detected by one controller:

C1	SELF TEST	C2
✓	O2 CELL 1	✓
✓	O2 CELL 2	✓
✗	O2 CELL 3	✓

If a cell is missing from one controller, that controller will not be active as a Master.

FAILED SELF TEST	
CONTROLLER 1	
DIVE NOW ?	
YES	NO

One oxygen cell NOT detected by both controllers:

C1	SELF TEST	C2
✓	O2 CELL 1	✓
✓	O2 CELL 2	✓
✗	O2 CELL 3	✗

If a cell is not seen by both controllers then the electronics will not go into Dive mode and the connection or solenoid must be fixed prior to use.

FAILED SELF TEST	
CHECK CELLS	

TIP: From software version 05.01.00 there is no need to switch off the electronics to re-connect one or all of the oxygen cells. Simply plug the oxygen cells in, the electronics will detect the cells as it cycles through the start up self-tests.

Solenoid NOT detected by one controller:

C1	SELF TEST	C2
✗	SOLENOID	✓
✓	BUZZER	✓

If the solenoid is missing from one controller, that controller will not be active as a Master.

FAILED SELF TEST	
CONTROLLER 1	
DIVE NOW ?	
YES	NO

Solenoid NOT detected by both controllers:

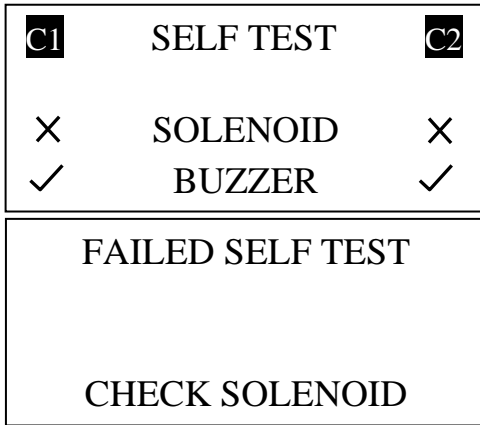

If the solenoid is not seen by both controllers then the electronics will not go into Dive mode and the connection or cell must be fixed prior to use.

If the solenoid and the oxygen can NOT be seen by both controllers:

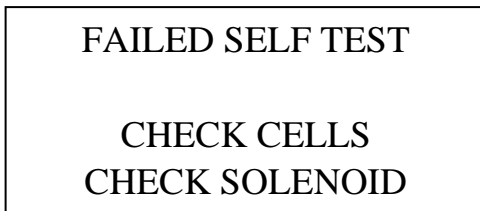

The electronics will not go into Dive mode and the connections must be fixed prior to use.

5.8 Battery Test

When the Solenoid and Oxygen Cell tests have been satisfactorily completed the Battery Test will commence.

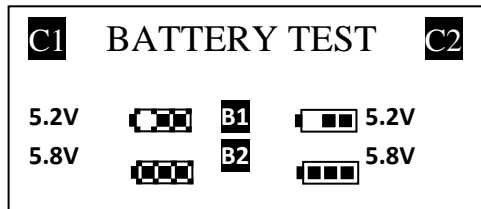
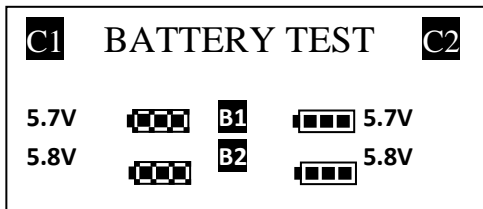

The solenoid “load” is placed on each battery compartment in turn and the battery voltage will be seen to drop. Each battery compartments voltage is measured by both oxygen controllers, C1 and C2. This test is designed to help eliminate weak batteries before you enter the water.

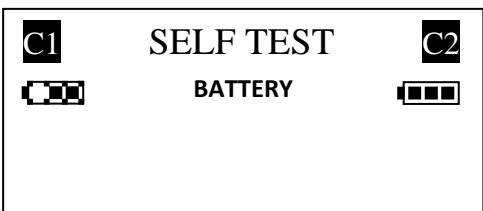

The batteries are tested while the solenoid fires and battery voltage is reflected in the icons.

- or = Good level (5.3 volts = 2 squares)
- = Pre-dive “BATTERY, NO DIVE”
- = Dive “Low Battery” Warning

During this test there is no “battery parachute” (the system which allows the 2nd battery to take over from the first in the event of a “voltage collapse”). If both battery compartment voltages are so weak that it drops below the “brown out voltage” then the system will simply shut down and new batteries will have to be inserted. If either of the battery readings are low before any load is placed upon them a “Failed Self Test” screen will appear first.

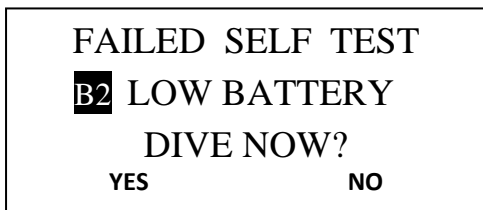

This warning screen shows battery B2 as low or missing. If YES is selected to DIVE NOW the Battery Test Screen will appear as before. A further warning screen will appear after the solenoid “load” test has been conducted.

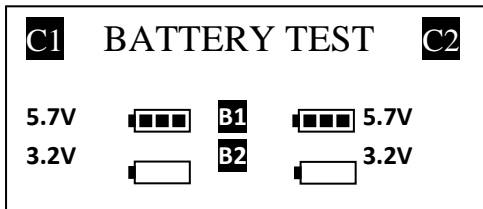

If YES is selected the battery test will commence as before. B2 may show some Voltage even if the battery is missing, this will disappear once load has been placed upon it and depleted any residual power from the capacitors.



WARNING – Selecting to continue the dive with only one healthy battery compartment is a feature that should only be used in an emergency, such as returning from a cave dive with no other means of escape. Spent or missing batteries should always be replaced under normal diving conditions.



When switching on, if one battery is down to one icon (approx. 5.2 volts) and the other battery has two or three icons a warning screen appears which requires a YES or NO decision to continue the dive. It is recommended that if a near the limits dive is planned, or if the apparatus had been stored at a low temperature, the battery should be replaced.

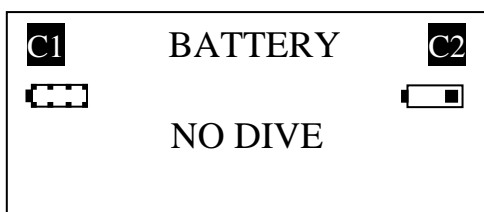

On switch on, if both batteries are displaying one icon or less - BATTERY – NO DIVE is displayed, the oxygen controller will not continue into dive mode and the dive cannot commence.



During the dive, once the battery voltage reaches approx. 4.8 volts, the battery is displayed as empty and a “Low Battery” warning is displayed.

5.9 Open O₂ Valve

Ensure the oxygen cylinder valve is open by turning anticlockwise one or two full turns and press the inflator whilst watching the pressure gauge. If the HP gauge needle moves when you press the inflator then the cylinder valve is closed and should be opened.

The arrow in the centre is requesting you confirm with the centre switch.

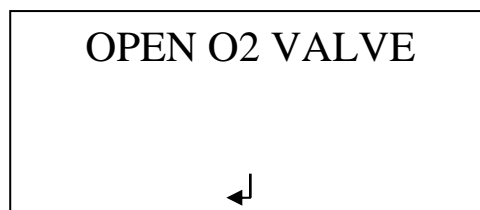

5.10 Open Diluent

The controller then prompts Open Diluent. Open the diluent cylinder valve fully and press the diluent inflator whilst watching the diluent pressure gauge. This checks all connections and that you actually have gas to that valve. If the HP gauge needle moves when you press the diluent inflator then the cylinder valve is closed and should be opened. Check ADV (Automatic diluent valve) operation if fitted by manually depressing the diaphragm cover.



5.11 Check Bailout

Check the location and function of your bailout system.

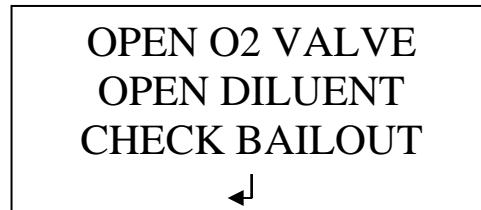

5.12 Check Counterlung Pressure Relief Valve

Fully open the pressure relief valve located on the counterlung by turning it anti-clockwise until it 'clicks' into the "DIVE" position. See Section 4 APPARATUS COMPONENTS for further details.



5.13 Check Mouthpiece Mushroom Valves

Have you tested the operation of your mouthpiece mushroom valves? See Section 4 APPARATUS COMPONENTS for further details.



5.14 Elapsed On Time

The display indicates the length of time, in hours and minutes that the unit has been switched on since the timer was last reset to zero. The option to reset the timer is given. This elapsed timer can be used to time any one of a number of events, such as time since last battery change, or time since last scrubber change. This timer must only be used as a guide, as the elapsed timer relies on the user resetting it. Also, as it may be reset at any time, care must be taken to ensure that no-one inadvertently resets the timer without your knowledge.

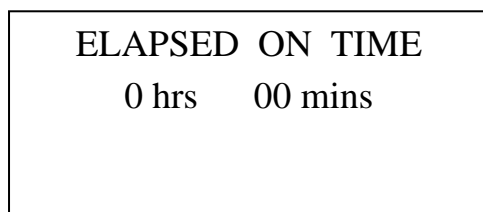
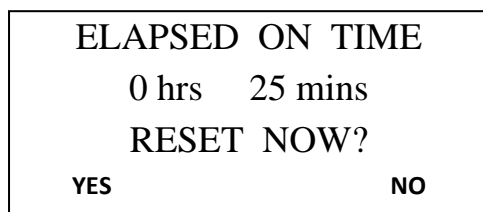

If Yes is selected then the elapsed on time is reset to zero. If No is selected then the current elapsed time is retained and the display moves to Calibration.

SECTION 6

6.0 CALIBRATION

The mVolt output of a cell varies with the ppO_2 . If the ppO_2 is higher, the voltage will be higher. A cell continues to measure the ppO_2 even in storage.

The mVolt output of a cell varies from one cell to another, even when exposed to the same ppO_2 .

Atmospheric pressure changes continuously. Consequently, the oxygen cells need to be calibrated prior to each dive or at least prior to each day of use to apply a calibration factor to each cell so they read the correct ppO_2 .

On the Inspiration, Evolution and Evolution+ this is a simple procedure, taking about 45 seconds. Every time it calibrates, the calibration factors are stored for future analysis of cells.

The calibration sequence involves surrounding the cells with oxygen at a known pressure (atmospheric pressure) providing the mouthpiece is open.

It is normal to calibrate before every dive. Valuable cell checks are included in the automated calibration procedure. To take advantage of all the cell checks ensure the gas mixture in the loop is close to 0.21 bar before calibration!

6.1 Must Calibrate!

MUST CALIBRATE	
Yes	No

The cells' stored calibration factors are used to calculate the PO_2 based on the cells' current outputs. If one cell has deviated compared to the others, MUST CALIBRATE! YES or NO is displayed. It is normal at this stage to calibrate by selecting YES.



WARNING: Calibrate on land with the rebreather standing upright, never in the water.

6.2 Calibrate?

CALIBRATE?	
Yes	No

If the ppO_2 displays are very close to each other using the previously stored calibration factors then the screen display shows - CALIBRATE? YES or NO. If the apparatus had only recently been calibrated then there would be little point in recalibrating. It is normal however, to calibrate prior to every dive and it is essential to recalibrate at least every 3 hours of diving.

If NO is selected the display goes straight into Dive Mode – Surface display.

6.3 Ambient Pressure

AMBIENT PRESSURE 1007mB

The ambient pressure is measured and displayed for a short period.

6.4 Oxygen %

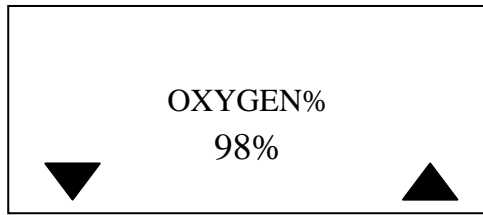

After displaying the ambient pressure value, the OXYGEN % is requested. It is requesting the oxygen % in the scrubber lid after the oxygen inject takes place during calibration.

This is an important issue. If there is 80% oxygen in the lid and 100% is entered, then the oxygen controller will always display the ppO_2 1.25 times higher than its actual value. The diver is likely to suffer Decompression Sickness (get bent). Typically a value of 98% or 99% would be entered when the oxygen cylinder contains 100% O_2 , the exact value can be determined- see section 6.8.4, "Periodic Calibration Check".



Warning The Inspiration, Evolution and Evolution+ are designed to be used with 100 % oxygen. Buying 100% oxygen is not too difficult in the UK. Diving oxygen is guaranteed by BOC or Air Products to be 99.99% pure and is certified as such. Welding oxygen is not analysed. Care must be taken with Medical oxygen as its oxygen content may vary depending on whether it will be used by midwives or by paramedics, or for other uses. There are grades of medical oxygen which contain CO_2 ! Specify diving oxygen. To determine the oxygen purity (when the oxygen % is not certified) see Appendix 2 - Determining the oxygen purity (when the gas purity is not certified).

6.5 Open Mouthpiece

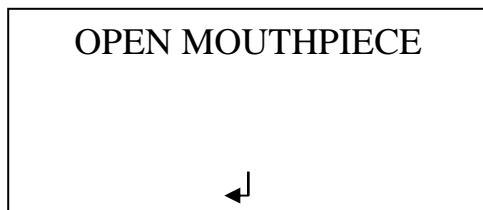

Once the oxygen percentage has been selected and confirmed by pressing the centre switch, the controller prompts OPEN THE MOUTHPIECE valve. The reason for this is to enable the cells to calibrate to ambient pressure and this would not be possible if the mouthpiece was closed.

Ensure the mouthpiece is open then confirm by selecting the centre switch. 6.6 Flushing

C1	FLUSHING	
0.17	0.19	0.20
C2		
0.18	0.20	0.20

The displayed ppO_2 readings from the three cells as seen by each controller will be seen to climb as the solenoid is opened and oxygen is fed into the loop. Do not worry that all three on the same controller are different - they will not be the same until they are calibrated. An individual cell when compared between C1 and C2 may be 0.01 different – this is normal, as each controller is calculating the displayed value based on its own cell reading and then rounding the calculated values to two decimal places.

6.6 Unsuccessful Calibration

A calibration may not succeed for a number of reasons e.g. you may have an air cylinder in place of the oxygen, you may have the oxygen valve closed, an oxygen cell may not be responding to the increased oxygen, an oxygen cell's output may be outside the expected range.

NO CALIBRATION
NO DIVE

In all instances the screen, "NO CALIBRATION, NO DIVE" is shown. The problem must be found and cured BEFORE diving again.

C1	CALIBRATED	C2
✓	O2 CELL 1	✓
✓	O2 CELL 2	✓
×	O2 CELL 3	×

To aid in the diagnostics, the cell that has not calibrated will be shown.

6.7 Successful Flush

C1	FLUSHING	
0.89	0.97	1.15
C2		
0.89	0.96	1.15



A lot of information can be gleaned during the flushing process with regard to the health of the oxygen cells. It is easy to compare the cell reaction speeds to oxygen and it is possible to see whether the cells have reached close to their full potential. The flushing process lasts until the cell outputs are stable.

C1	CALIBRATING	
0.89	0.96	1.15
C2		
0.89	0.97	1.15

Once the controller is satisfied with the cell outputs then the CALIBRATING message is shown.

C1	CALIBRATED	
0.98	0.98	0.98
C2		
0.98	0.98	0.98

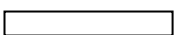
DIVE MODE-SURFACE

C1	0.7		
	0.98	0.98	0.98
	DIL1 AIR		
	13:50:26	1000mB	



Warning Be aware - it is possible to fool the oxygen controller! After use there is a high oxygen content in the loop. If the oxygen valve has been turned off and a second recalibration is selected, the oxygen controller will recalibrate despite the fact that the oxygen cylinder valve is closed. This will give an inaccurate calibration. What is more, the dive is about to be commenced with the oxygen cylinder valve closed! You must ensure the gas mixture in the loop is close to 0.21 bar before calibration! This is easily done, by either breathing from the loop or by flushing with diluent.

6.7.1 Verification of ppO₂

Rule No.1 with any rebreather is “KNOW YOUR ppO₂ - know what you are breathing”. Never, ever, breathe from a rebreather unless you know what you are breathing. There are methods of obtaining your ppO₂ when diving a Closed circuit system:

1. Breathe from a pre-analysed open circuit supply i.e. don't use a rebreather
2. Look at a ppO₂ display
3. Flush the loop with fresh gas, usually a known diluent, providing it is life sustaining at your depth.

Methods 1 and 3 we can use in emergencies, so in normal use we have to use the ppO₂ display to warn of changes in ppO₂. The ppO₂ you breathe is important not just for keeping you alive but slight reductions in ppO₂ may cause you to suffer decompression sickness (you'll get a bend).

Hopefully by now, you understand the importance of looking at the ppO₂ display, so now it is important to verify that the display is giving you accurate information.

6.7.2 Indicators to look for during calibration

1. **Cell Reaction time?:** Start with air in the loop. As oxygen is injected during calibration compare the three cell displays to see whether they are all changing value at the same rate. If you have a slow reacting cell, then it will result in a “cell warning” during the dive, especially during diluent flushes.
2. **Cell values prior to the “calibrating” message shown on the display:** The cell readings must be stable for a calibration to occur. Just prior to “calibrating” being shown on the display, read off the values for all three cells and make a note of them. The cell values are likely to be different and should lie between 0.7 and 1.35. When you do the calibration, compare these ‘end’ values with those recorded in your manual. In this way you can see whether the sensor face is occluded or if the cell is starting to deteriorate (as we expect them to near the end of the cells life).
3. **Cell Evaluation During Calibration:** When they are new, oxygen cells have an output of between 7.6 and 13 mVolts. With the rebreather cell validation routine, the calibration will be discontinued if the cell's output is outside the range 7 to 13.5 mVolts. If you see “cell out of range” on the display, the cell **MUST** be changed prior to diving. There is an exception to this: “cell out of range” would be displayed if you entered the wrong O₂ % so check this before stripping out the cell. i.e. if you only have 80% O₂ in the oxygen cylinder enter 78%-80% at the prompt, not 98%. **But please note: it is completely abnormal to use anything other than 99-100% oxygen in the O₂ cylinder.**
4. **Time taken to calibrate:** Due to the fact that the cell readings must be reasonably stable for a calibration to take place, the time taken to calibrate will vary depending on the ppO₂ in the loop prior to calibration. A lower ppO₂ at the start (0.21) will result in a longer calibration time than when starting with a higher ppO₂ in the loop. It is best to start with air in the loop and so you get a good indication of how the cells are reacting to changes in ppO₂. Should the calibration occur much quicker than expected, it is prudent to switch off and on and re-calibrate.

6.7.3 Checks prior to each use

Prior to diving, press the diluent inflation button. The displayed ppO₂ values will drop. Check that all cells change value quickly (a slow change indicates moisture on the front face of that cell). Once the ppO₂ drops below 0.4 bar the low oxygen warning will display and the warning buzzer sounds.

After a delay of up to 3 seconds, the oxygen solenoid will open and O₂ will be injected to bring the ppO₂ back up to and just over the set point of 0.70 bar. Check to ensure that all 3 sensors reach the 0.70 bar set point without any individual cell lagging behind the others.

Manually inject oxygen and ensure that all 3 cells reach atmospheric pressure without any individual cell lagging the others, have similar values and react at roughly the same speed. During the pre-breathe sequence ensure the ppO₂ values drop as you exhale into the loop and then ensure all cell values are brought back to setpoint as oxygen is injected.

6.7.4 Periodic Calibration Check

During constant depth phases of the dive the ppO₂ at the mouthpiece is held within a very tight band, typically within ± 0.02 bar of the mean (You will see bigger swings on the displays because they show the oxygen pressure in the mixing chamber (the scrubber lid)). However, the accuracy of the mean ppO₂ depends on the calibration information you give it. If you enter the wrong values, the ppO₂ will still show that the oxygen level is around the setpoint (1.3) but the true O₂ pressure will be offset from the displayed value and this could be dangerous. The degree of danger depending on the value of the offset and on the type of dive you are doing. If you are doing a “push it to the limits” decompression dive, then you may get bent.

The accuracy of the calibration depends on the percentage of oxygen in the cylinder and the injection rate of O₂ into the scrubber lid. The oxygen injection varies slightly from rebreather to rebreather but its effect on calibration is something that is easily checked. After calibration open the mouthpiece slightly and operate the oxygen inflator. Keep pressing the button until the ppO₂ stops rising. Release the button and wait for 5 seconds before reading the values on the display. These should be reading the same as the atmospheric pressure. Often, the readings will be slightly higher than that, so switch off the handset, flush the system with air and do the calibration again. This time entering a lower oxygen % than you did last time. Repeat until you find the correct oxygen % to enter for your rebreather. Once you find the correct oxygen% to enter for your rebreather, use that value from then on. Test it again at monthly intervals and test whenever you change oxygen supplier or have any reason to doubt the percentage of oxygen in the mixing chamber.

Important: the oxygen % asked for is the oxygen % in the mixing chamber (the scrubber lid), NOT the oxygen % in the cylinder. (Have the scrubber lid serviced annually by the factory or an approved service house and they will check the solenoid’s flow to ensure it is within limits.)

This method improves the accuracy of the ppO₂ display but you should continue to use values of setpoint ± 0.05 bar for calculating decompression and oxygen toxicity. e.g. If the setpoint is 1.3, use 1.25 for deco planning and 1.35 for oxygen toxicity planning. This takes into account other factors that affect the accuracy, such as humidity.

6.7.5 Linearity Check

The oxygen cell output is linear at the oxygen pressures we normally breathe in the rebreather, but nevertheless it is prudent to check the linearity periodically and especially after a scrubber flood and clean up. Flush with oxygen, see if the ppO₂ reaches the atmospheric pressure and then flush with air and see if the display reads 0.21 bar. Any variation outside the range 0.19 to 0.23, the cells should be considered faulty and should be removed for further analysis.

The output of all cells is non-linear above a certain ppO₂. After that point you can increase the ppO₂ as much as you like but the cell’s mVolt output will not increase. When the cell is new, this occurs at approx. 4 bar ppO₂. As the cell is used the lead anode is consumed and the ppO₂ at which the cell becomes current limited reduces. Once you have one cell that is current limited then it can affect the oxygen controller. If you have two cells that become current limited below the setpoint (e.g. 1.3 bar) then they will dominate the oxygen control system causing oxygen to flow into the loop unabated. The best way to avoid this scenario is to simply insert new cells at 18 months from the date of manufacture, which is on every cell in a simple coded format (e.g. D9 = April 2009). To check for non-linearity simply add manually a small amount of oxygen and verify that the ppO₂ display goes above the setpoint. If it does, the output is linear in the operating band.

6.7.6 Verifying the ppO₂ during the dive

The computer makes the assumption that the nearest two cells must be correct - it is a simple voting logic system. However, do not be lulled into thinking the same way as the computer as the nearest two cells might be the faulty ones.

For each of the three oxygen cells, the cell's mVolt output is simply converted to a ppO₂ and is shown in real time. Because the electronics display raw data in real time, the reaction time of the display is instantaneous and this "reaction rate" is a good visual indicator as to the health of the oxygen cells and electronics.

Remember this:

As the ppO₂ in the loop changes - the display for all 3 cells SHOULD change!

Check on every dive to see if all cells are reacting to gas changes.

By forcing changes in ppO₂ you can examine the health of the cells at any stage of the dive. Simply add a little oxygen to bring the ppO₂ 0.05 to 0.1 bar above the setpoint and then add a little air/diluent which should lower the ppO₂ below the setpoint. This proves whether or not all three cells are responding to changes in ppO₂ and are capable of displaying above and below the setpoint.

If any cell refuses to display above the setpoint, the dive MUST be aborted and the cell replaced. If they are all the same age - replace all three.

It has become common practise to replace oxygen cells on a rolling basis, i.e. Insert one new cell every 6 months.

Additionally the ppO₂ values may be checked during the dive by flushing with O₂ in the shallows (less than 6m) or by flushing with air/diluent when deeper. At depth you expect the following ppO₂ when you flush with air:

10m - 0.42 bar
20m - 0.63 bar
30m - 0.84 bar
40m - 1.05 bar
50m - 1.26 bar.

It is advisable to write the ppO₂ values for your diluent for every 10m on your decompression slate. This is used as a rough check to see which sensors are giving proper readings should you ever be in any doubt regarding the displayed information. It can only be regarded as a rough check because of the variations between depth gauge readings and different divers' abilities to do effective gas flushes but nevertheless it is still an excellent check and at the same time changes the ppO₂ in the loop to a known value, providing the flush is done effectively.

In the Dive Mode - Underwater Menu, when deeper than 1.2m, there is a useful "Cell Check" display which calculates what the ppO₂ will be if you flush effectively at your current depth. The display on the left is the ppO₂ should you flush with diluent and the display on the right is the ppO₂ should you flush with oxygen.

SECTION 7

7.0 DIVE MODE

7.1 Dive Mode - Surface Display

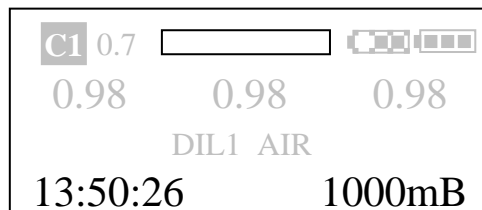
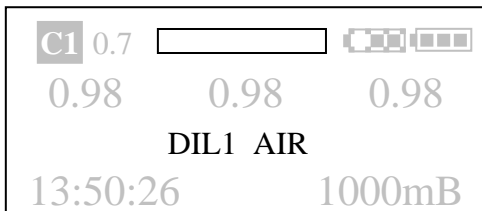
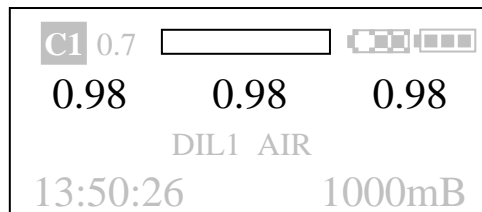
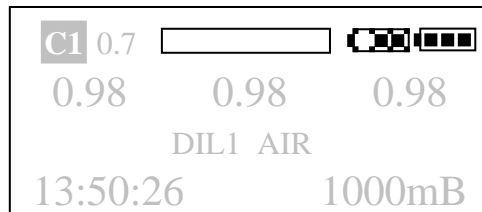
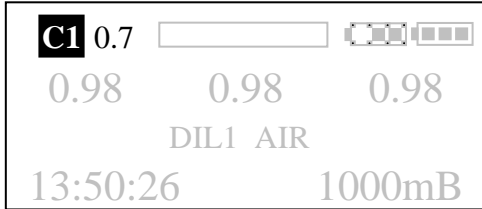
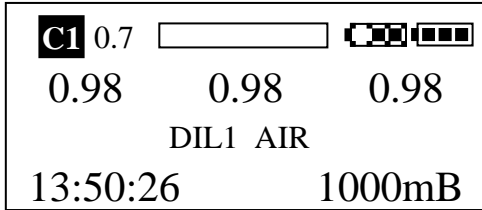

C1 indicates that Controller 1 is the Master controller.

0.7 indicates the setpoint is 0.7 bar

The empty box in the centre top of the display is the CO₂ scrubber monitor, (replaced with dashed line when Temp-Stik not connected.)

The left battery indicator is B1 and is the battery compartment that drives C1. The right battery - B2, drives C2. B1 is highlighted to indicate it is the Master Battery (the Master supplies power to the solenoid and wrist mounted display).

These three figures represent the ppO₂ readings from the oxygen cells. Cell 1 is on the left, cell 2 in the centre, cell 3 on the right.

The diluent is shown in the centre of the display. The diver MUST be satisfied that this is the diluent being used.

The current time is shown in the bottom left corner and the current ambient pressure is displayed in the bottom right corner.

7.2 Master/Slave Controllers.

If Controller 1 (C1) is capable of being a Master controller the electronics will always start with C1 as Master and C1 will be displayed in the top left corner. The Master controller is the one used for operating the solenoid to maintain ppO₂.

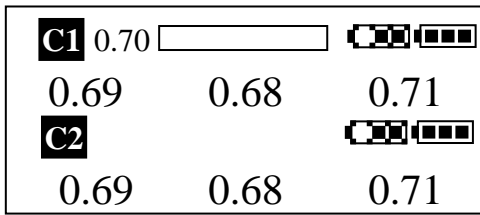

C2 can be displayed by pressing the left switch and holding for 2 secs.

Normally the C2 display is not shown unless an error exists for C2 when the error message will be alternated with the C2 ppO₂ and battery information and dive time and depth information. Should the depth and time be required during the warning sequences simply press and hold the right button for 2 secs.

The Slave simply takes the mVolt outputs from the same three cells as the Master controller but it calculates the ppO₂ values for itself, so it is common to see the Slave display varying from the Master by ± 0.01 bar. If at any time the Master is switched off or powers down or its processor stops, the Slave recognizes this and automatically becomes the Master, taking control of the solenoid. Additionally, the Slave is programmed to maintain a ppO₂ at 80% of the setpoint as a “catch all” should the Master fail to maintain the desired setpoint.

7.3 Master/Slave Batteries

If C1's batteries, B1, have sufficient power to qualify as the Master battery, then the electronics will always start up with B1 as the Master battery. The Master battery is used to power the wrist mounted display and the solenoid.

The Master's battery is highlighted, shown here on the left:



If B1 has insufficient voltage to be the Master battery then C2's batteries (B2) will be designated as the Master battery. In use, it will be possible to see C1 as the Master controller but B2 being used as the Master battery. In the same way it would be possible to see C2 as the Master controller but using B1 as the Master battery.



In the event that both B1 and B2 are below the low battery levels then the power to drive the wrist display and the solenoid is drawn from both batteries simultaneously.



When a battery reaches the low battery level during the dive, the warning is displayed on both the wrist mounted display and the relevant HUD. This warning may then be suppressed for 5 mins by pressing the right switch for 2 secs.

7.4 ppO₂ display

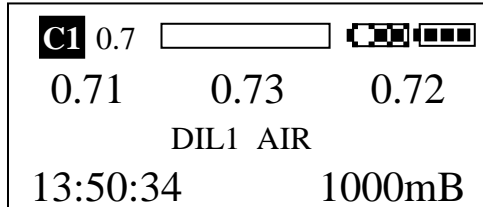
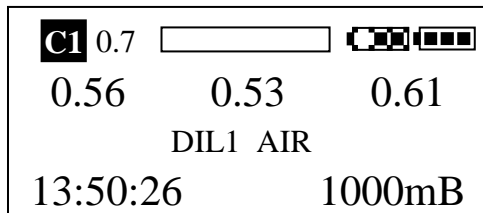

When first breathing on the rebreather, a rapid drop in ppO₂ will be seen. Obviously the drop in ppO₂ occurs because the exhaled breath contains only about 17% oxygen and you are forcing the oxygen pressure down very quickly. If you stop breathing into the loop, just take it out of your mouth, you should then expect to see the ppO₂ rise rapidly back towards the setpoint. Please remember there is always a 6 second delay between solenoid open times, so don't expect the solenoid to always open immediately the ppO₂ drops below the setpoint, there is often a short delay. This is a great indicator of the "health" of the system, now you know whether or not the cells are reacting to fast changes in ppO₂, you know the oxygen controller and solenoid are

working and has oxygen rich gas connected. If you continue to breathe from the loop, it will take about 3 minutes of breathing to bring the ppO₂ of both the lungs and the breathing loop to a steady state 0.70 bar. Once at the setpoint the controller will maintain the ppO₂ very close to the setpoint. In independent tests it is proven to be maintained within ± 0.02 bar during the dive. During ascent the ppO₂ will drop due to decreasing ambient pressure but steady state setpoint is achieved at the mouthpiece within 20 seconds of reaching a decompression stop.

7.5 Dive Mode - Underwater Display

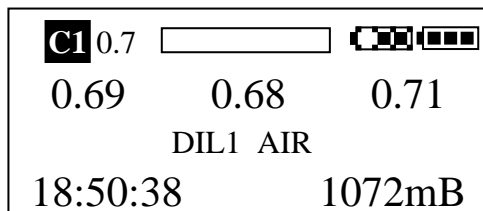

As the diver descends the ambient pressure display increases.



Once a depth of approximately 1.2m (4 ft) has been reached, the display changes to its underwater display. It reverts back to surface display at approx. 0.9m (3ft).

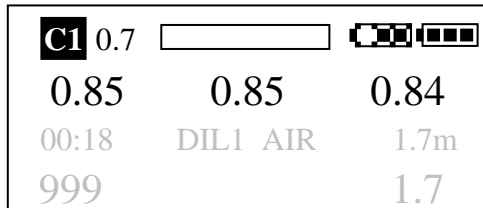

The top two lines are the same as the Dive Mode – Surface. The ppO₂ detected by the oxygen cells is displayed across the centre of the display.

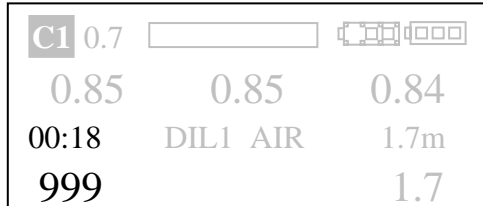

The dive time is shown, in this example, as 0 mins, 18 secs. The No-Stop time, if a decompression option is purchased, is displayed below the dive time and is shown as 999 mins.

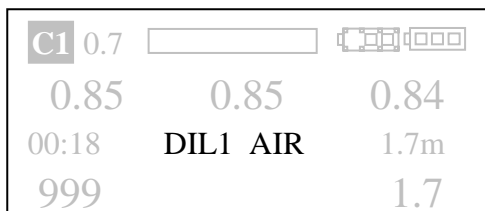

The selected diluent is shown in the centre of the display: Diluent 1, which is AIR. On the deco versions there are up to 6 diluents, all of which are user adjustable and stay in memory once set.

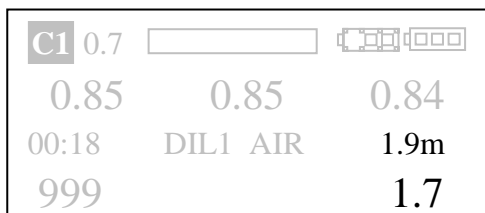

The maximum depth is shown here as 1.9m and the current depth, 1.7m, is displayed in the bottom right corner.

7.6 Switch Functions – Dive Mode

Once into a Menu, the switch selection is indicated in the screen above each switch. The exception to this is in the underwater Menu. At Cell Check, by pressing the unlabelled centre switch more options are displayed.

There are also several functions available by learning the following switch sequence. The good news for Classic rebreather owners is that the switch sequence is virtually identical. The only exceptions being that now when in dive mode, you can suppress some warnings by pressing and holding the right hand switch which also conveniently brings up instantly the depth and time information. You can also display the Slave controller by pressing and holding the left switch for 2 secs.

Start up:

Left switch - **hold** - turns the unit on.

When in dive mode:

- Left Switch, no hold - backlight comes on for 5 secs
- Centre Switch, no hold - backlight comes on for 15 secs
- Right Switch, no hold - backlight comes on for 15 secs

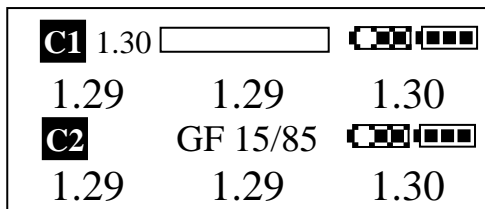

Left Switch, 2 second hold – displays the Slave's ppO2 and battery readings on the bottom two lines of the display. The Gradient Factors are displayed in the centre of the screen (Trimix Version only).

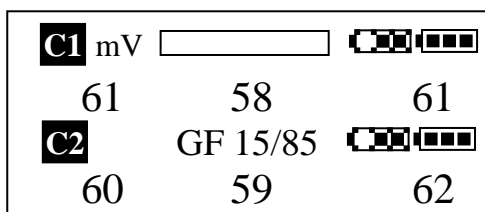

Left Switch, 4 second hold – displays the raw cell readings in mV, at a resolution 1 mV.

Centre Switch, long hold - toggles the high and low setpoints.

Right Switch, long hold - suppresses battery warnings, cell warnings, dive start violation and first level CO₂ warnings for 5 mins. It suppresses any warning sequence for an instant look at depth and time information.

NOTE: Low oxygen, high oxygen, ceiling violation and last level CO₂ warnings (if Temp-Stik fitted) cannot be suppressed.

Centre and Right Switch, simultaneously - Controllers On/Off Menu

Left and Right Switches, simultaneously - Enter Menu Mode

Left and Right Switches, simultaneously (whilst in Menu mode) - Exits Menu Mode

7.7 High/Low Setpoint Switching

By selecting a LOW setpoint (0.70 bar) the diver can descend with less risk of the ppO₂ spiking high. By switching to a HIGH setpoint (1.30 bar) decompression obligations can be minimised. Typically, the LOW setpoint is used during the descent down to about 24 to 30m when the HIGH setpoint is selected. The HIGH setpoint is then used for the ascent and decompression, switching to the LOW setpoint prior to ascending above 3m.



Typically dives to 12m or shallower are conducted entirely on the low setpoint. For dives 12m and deeper the High setpoint is used for the bottom and ascent phases – bear in mind the CNS and OTU limits (CNS limit at 1.30 bar is 3 hours), see section 3.5.5 and 3.5.6 .

When in dive mode, pressing and holding the middle switch for three seconds will switch the Setpoint from LOW to HIGH. Releasing and pressing for another three seconds will switch back to the LOW setting. This 3-second hold time is to help prevent accidental operation during the dive.



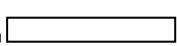

WARNING: Selecting the HIGH setpoint when at the surface, will result in oxygen being injected to bring the ppO₂ in the loop up to meet the HIGH setpoint. If the HIGH setpoint is set above the ambient pressure the controller will continue to inject oxygen until either the LOW setpoint is selected, the power is switched off or the rebreather runs out of oxygen or battery power! i.e. 1.3 bar in the loop cannot be achieved until the apparatus is deeper than 3 m!

The Vision (version 05.01.00 onwards) features AUTO and gradual setpoint switch methods which are activated in the CCR menu (see section 8.1.3). The choice of whether to use the AUTO or gradual feature or not is the diver's choice. Once selected, the AUTO or gradual switch and settings are retained and used until changed by the diver. If AUTO is selected the diver may manually override the current setting – at any time, by simply pressing and holding the centre switch for 3 secs. Whether the diver uses AUTO, Gradual or Manual – it is of paramount importance that the diver knows what setting is being used at all times. There is a great risk, in fact certainty, of decompression requirements being extended if the dive is conducted on a low setpoint, for further information see section 1.7.

C1 0.7 		
0.69	0.68	0.71
25:40	DIL1 AIR	21.7m
999		21.7

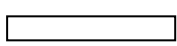
Dive Mode – Underwater
Low Setpoint (0.7bar) selected. Manual setpoint switch mode is indicated by  next to setpoint.

C1 1.30 		
1.06	1.10	1.08
26:00	DIL1 AIR	21.7m
999		21.7

High Setpoint Selected (1.30bar). Oxygen is now injecting to bring the ppO₂ up to 1.30. The lack of  next to the setpoint indicates the setpoint switch mode is set to AUTO.

7.8 Head Up Displays (Hud) – Dive Mode

The Head up Displays are an important part of the life support system. There are two Head up Displays, one for C1 and one for C2. They have independently driven LEDs (light emitting diodes), the light from which is brought forward through dedicated fibres for each of their two LEDs (4 fibres in total) to a common mounting at the mouthpiece. C1 controls two lights (or fibre optic ends) one above the other on the left (red above green), C2 controls the two on the right. Once switched on, the Head up Displays' LEDs cannot be switched off unless a Power Off signal is received from the wrist-mounted display. Should there be a failure within the wrist-mounted display the only way to stop the operation of the HUDs' LEDs is to remove the batteries.

The LEDs for the HUDs are located in the lid of the scrubber immediately adjacent to the C1 and C2 oxygen controller boards. The boards are encapsulated for waterproofing and vibration proofing. The light from the diodes is transmitted via flexible polyethylene fibre optic cables to the mouthpiece mount. NOTE: although flexible, care should be taken not to over-bend the rods.

The use of fibre optics eliminates the need for waterproofing or pressure proofing and the fibre optic cables are easily replaced at relatively low cost. If this is undertaken by the diver or repair technician, care must be taken to ensure the correct cables are inserted in the correct slot so C1's green is bottom left, C1's red is top left, C2's green is bottom right and C2's red is top right. It would be prudent for the diver to check this after a service by switching the unit on with just one battery in at a time, take it into dive mode and check the position of C1 and C2's green lights.

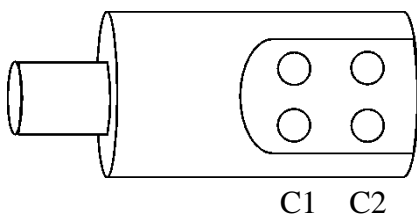

No lights:
Not in Dive Mode – NO DIVE !

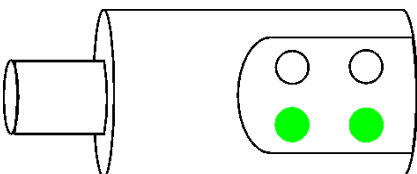

Steady green lights:
Both C1 and C2 are in Dive Mode and the ppO_2 is close to setpoint.

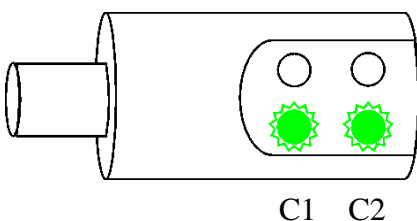

Green light flashing:
The ppO_2 has fallen below setpoint by 0.2 bar or more.

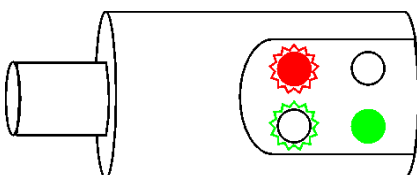

Green and Red lights flashing alternately on C1:
Low Battery warning on C1

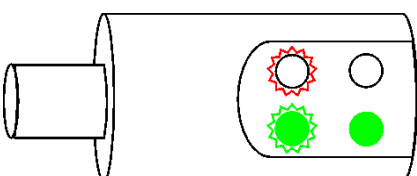

Hint: concentrate on C1; assess what that is telling you before concentrating on C2. If in doubt, look at the wrist display.

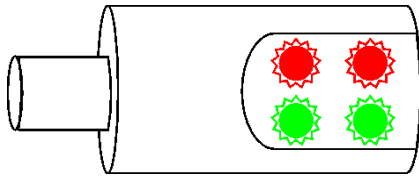

Green and red lights flashing together on C1 and C2:
Cell warning on both C1 and C2.

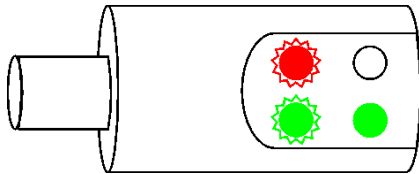

Green and Red lights flashing together on C1:
Cell warning just on C1

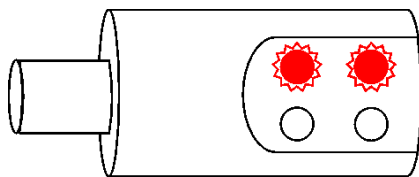

Flashing Red on both C1 and C2:
Fast flash = High ppO₂ warning (over 1.6 bar)
Slow Flash = Low ppO₂ warning (below 0.4 bar)

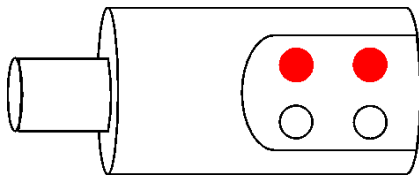

Solid Red:
LOOK AT HANDSET NOW!
This is a general warning used to draw the diver's attention to the handset. This is used for the CO₂ scrubber monitor, CNS, and OTU warnings plus additional warnings created in future product development.

SECTION 8

8.0 MENU MODES

NOTE: THE MENUS ARE SLIGHTLY DIFFERENT DEPENDING WHETHER THE DISPLAY IS IN SURFACE MODE OR UNDERWATER MODE.

NOTE: THE MENU MODE IS ENTERED WITH HIGH OR LOW SETPOINT SELECTED.

NOTE: The oxygen control is maintained when in Menu Mode.

NOTE: There is a 15 secs timeout. If a switch is not selected within 15 secs the display reverts back to Dive Mode, either “surface” or “underwater”. This is a useful facility allowing you to scroll down to the feature to be altered, make the alteration and then just wait until it drops back into dive mode. It saves going through the entire Menu.

NOTE: Once into a Menu, the switch selection is indicated in the screen above each switch. Generally, if the current setting is required then the centre switch, if its operation is not indicated to do something else, selects the current setting and then the next option is displayed.

8.1 Menu Mode – surface –CCR

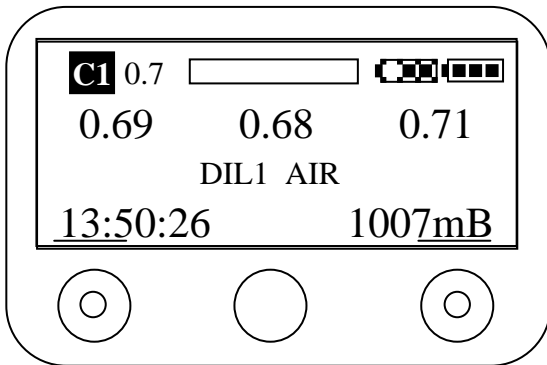

Press the outside two switches, simultaneously or within 0.5sec of each other, to enter MENU Mode

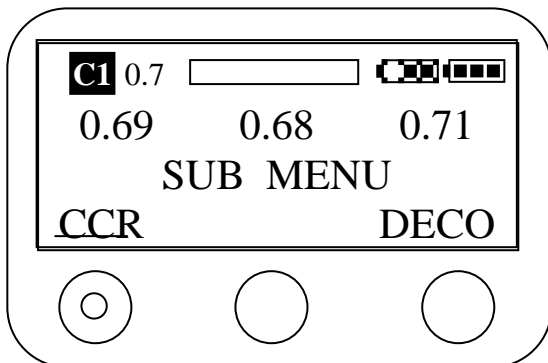

Now, you have the choice of two menus; Rebreather (CCR) or Decompression. Select CCR.



8.1.1 High Setpoint Adjustment

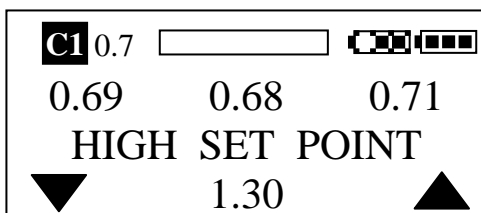

The default high setpoint is 1.30 bar, but is adjustable from 0.9 to 1.5. It always defaults back to 1.3 when the electronics are turned off. Tip: leave it on 1.30 bar. Press the centre switch to confirm selection.

8.1.2 Low Setpoint Adjustment

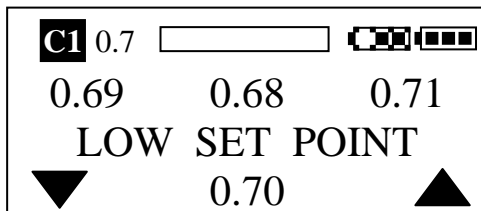

The default low setpoint is 0.70 bar but is adjustable between 0.5 and 0.9. It always defaults back to 0.7 when the electronics are turned off.

Tip: leave it on 0.70 bar.

8.1.3 Setpoint Switch on descent

By selecting a LOW setpoint (0.70 bar) the diver can descend with less risk of the ppO₂ spiking high. By switching to a HIGH setpoint (1.30 bar) decompression obligations can be minimised.

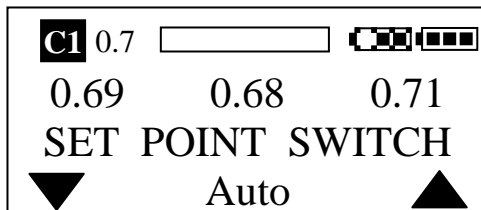

The LOW setpoint is used at the surface and for the descent. When diving deeper than 30m the HIGH setpoint should be selected for the descent at 25-30m.

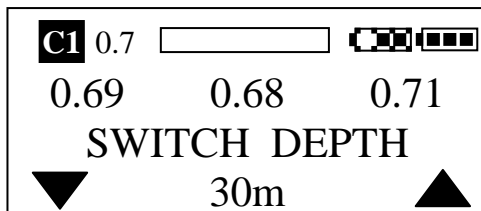

The switch from LOW setpoint to high setpoint can be set to take place automatically by selecting AUTO. The next screen allows you to select the switch depth. Whatever depth you set it to will be remembered the next time you switch on. Press the centre switch to select the depth and move to the next menu option.

NOTE: If AUTO is selected, the setpoint can still be toggled manually between HIGH and LOW setpoints at any time. If underwater and in AUTO mode; if the diver tries to set high setpoint when shallower than the 100% O₂ depth (e.g. at 2m with a 1.3 setpoint) the electronics will force to the low setpoint.

NOTE: The switching method is set to AUTO (30m) when shipped from the factory. This is obviously not suitable for all dives and needs to be adjusted to suit individual circumstances.



WARNING! Whether AUTO or MANUAL is selected, it is the diver's responsibility to ensure that the high setpoint is selected at depth. Failure to ensure this may result in decompression sickness. Alternatively the gradual setpoint can be used, see section 1.7.

8.1.4 Setpoint Switch on ascent

On ascent the setpoint switch is done manually by the diver; by pressing and holding the centre switch. However, if AUTO setpoint switch is selected, once the diver reaches the 100% O₂ depth the controller will automatically switch the setpoint to LOW if the diver hasn't already selected it. i.e. if a HIGH setpoint of 1.30 bar is used the LOW setpoint will be selected at approximately 3m. If a HIGH setpoint of 1.40 bar is used the LOW setpoint will be selected at approximately 4m. (The depth at which the change is made is approximate because the depth will actually change with the atmospheric pressure). If the MANUAL setpoint switch is selected the setpoint will stay on the high setpoint all the way to the surface, unless changed by the diver.

8.1.5 HUD Intensity

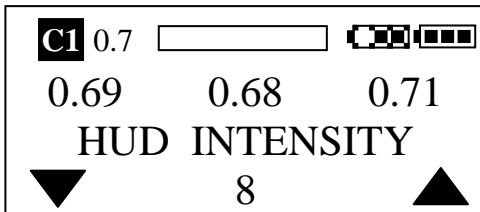

The intensity of the head up displays' LEDs may be altered to suit the ambient light. A night dive may require a lower intensity. Adjustment range is 1 to 10.

8.1.6 LCD Contrast

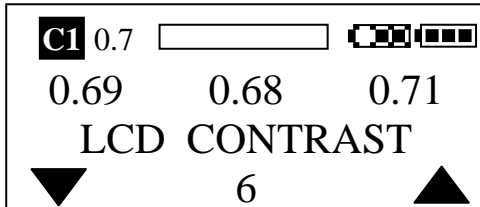

The contrast of the liquid crystal display may be altered to suit the ambient temperature. Altering the contrast has no effect on battery life. The adjustment range is 3 to 10.

8.1.7 Backlight Options



If Key On is selected, the backlight is normally off but comes on when a switch is pressed. The left switch operates the backlight for 5 secs, the centre or right switch operates the backlight for 15 secs.

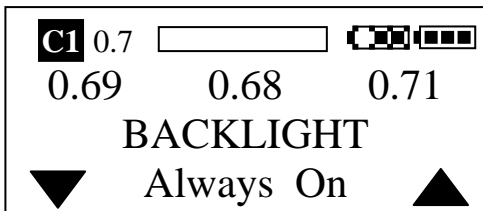

Press the right switch to get to "Always On" - a useful feature on a deep dive or in cave but remember the battery drain will be much faster and MUST be monitored closely.

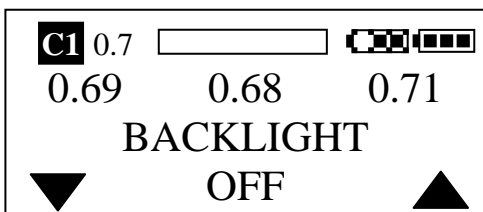

Press the down arrow once to go from "Key On" to Backlight OFF. This may be chosen in high ambient light situations to extend battery life.

Once the choice required is displayed, press the centre switch to select.

8.1.8 Backlight Brightness

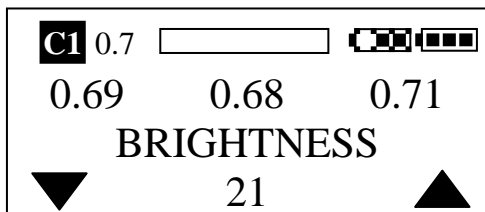

The backlight is the 2nd biggest power consumer. The maximum setting is 31. By setting this to 21 there is a saving of 30mA. Press the centre switch to select. Adjustment range is 1 to 31; the lower the number the lower the current-drain on the batteries.

8.1.9 Elapsed On Time - Display and Reset.

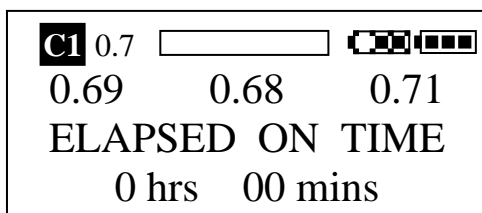
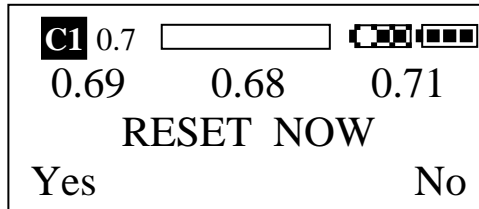
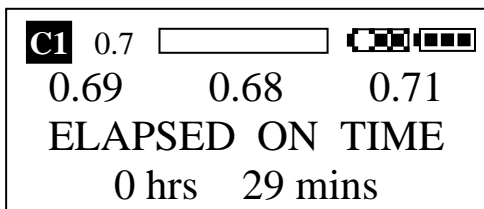

If Yes is selected the time starts again at zero.

8.2 Menu Mode - surface -DECO

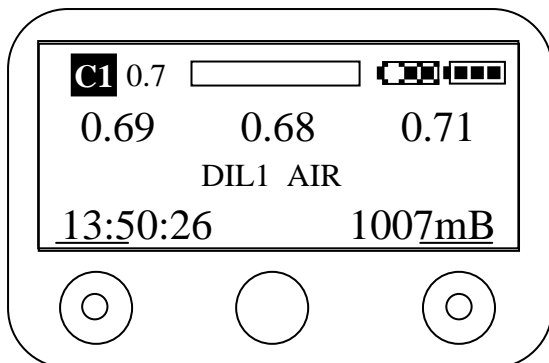

Press the outside two switches, simultaneously or within 0.5sec of each other, to enter MENU Mode
Note: press the outside two to exit menu when required.

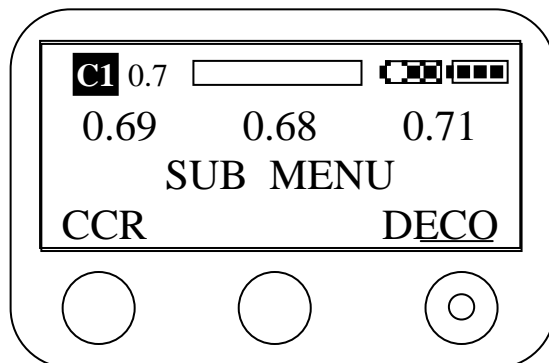

Now, you have the choice of two menus, Rebreather or Decompression. Select DECO.

Note: the DECO Menu works slightly differently to the CCR menu. Each DECO Menu option has two arrows; these allow you to scroll up and down through the selection options. To exit this Menu you either scroll to the "Exit Menu" option or you just wait for 15 secs when you will be bounced back to the main Dive Mode (surface) display.



NOTE: the following sections are not necessarily shown in the same order as they appear on the product. The features available vary with Dive Timer, Recreational 1, Recreational 2, Nitrox and Trimix versions. See Appendix 1 for relevant Menu options.

8.2.1 Select Diluent

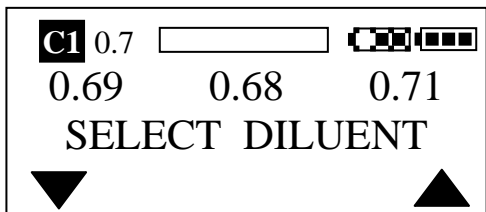

To select diluent, press the centre switch.

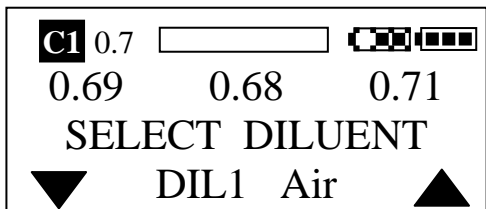

The current diluent choice is displayed. Press the left or right switch to scroll through the 12 diluents.

NOTE: The diluents programmed in at time of delivery, for the Trimix deco software option are: Diluent 1 – AIR, Diluent 2 – 16/44 (O₂%/He%), Diluent 3 – 13/59, Diluent 4 – 10/52, Diluent 5 – 36% Nitrox, Diluent 6 – 80% Nitrox, Diluent 7 to 12 – AIR.

NOTE: All gasses are adjustable and then stored at YOUR new settings for future use.

NOTE: If you have the Dive Timer version, there is no “Select Diluent” display. If you have the Nitrox deco option, the Helium % defaults to 0.

If diluent 3 is required, scroll to diluent 3 and select by pressing the centre switch, otherwise scroll through diluents.

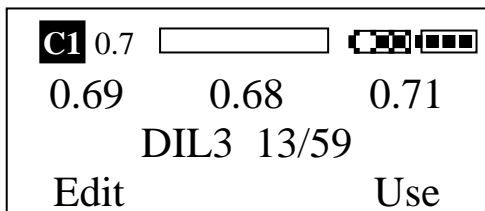

To confirm diluent 3, confirm by selecting Use. If a change is required select “Edit”.

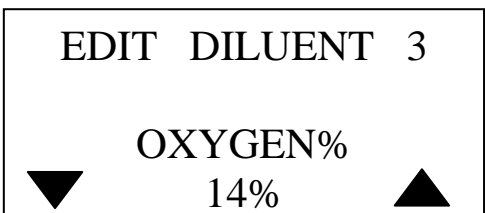

The first option is to change the oxygen percentage. Confirm by pressing the centre switch.

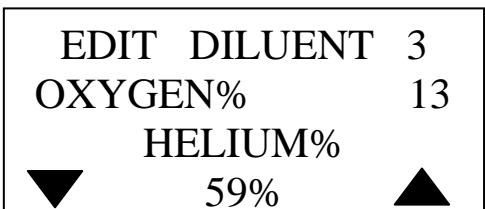

Next, it is possible to adjust the Helium %. If Heliox were being used then increase the Helium % to eliminate any Nitrogen.

EDIT DILUENT	3
OXYGEN%	14
HELIUM%	59
NITROGEN%	27

The Nitrogen % is automatically calculated and displayed for a few seconds before scrolling onto the next Menu option.

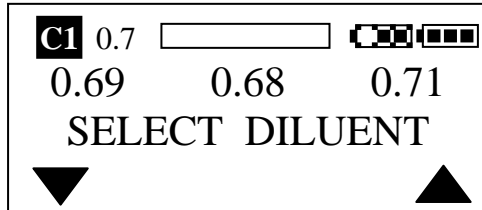

To change another diluent press the centre switch again or move onto the next option by pressing the left switch.

8.2.2 Gradient Factors (Trimix version only)

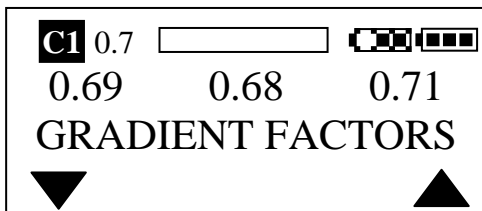

If the Trimix deco software option has been purchased there is the possibility to alter the Gradient Factors.

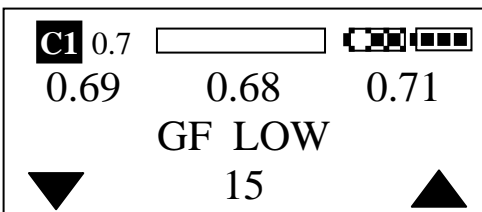

The Low Gradient Factor inserts deep stops. If deeper stops are required, decrease the Low Gradient Factor.

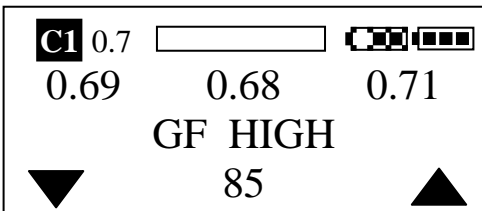

Decreasing the high gradient factor increases the duration of the shallow stops.



WARNING: By using a Low factor of 100 and a high factor of 100, the decompression profile will be straight Bühlmann. However, according to Bühlmann, this results in an unacceptably high incidence of DCS(Decompression Sickness). Bühlmann recommended an additional safety factor be applied: an addition of $1.03 \times \text{depth} + 1\text{m}$. This equates to a gradient factor of approx. 90 High, 90 Low. No matter which decompression program is used, it will never reflect exactly what is happening to the body, it is a best guess and there isn't a decompression program in existence, including this one, even if dived well within the "safety" limits, that will guarantee no decompression sickness.



WARNING: The Gradient factors MUST be checked by YOU prior to EVERY dive.

8.2.3 Conservatism Level (Nitrox version only)

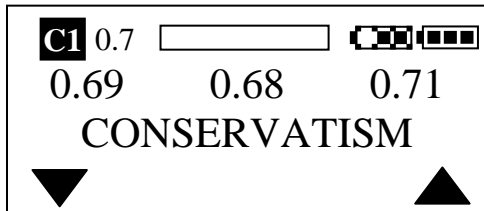

If the Nitrox decompression option has been purchased there is the possibility to alter the conservatism level.

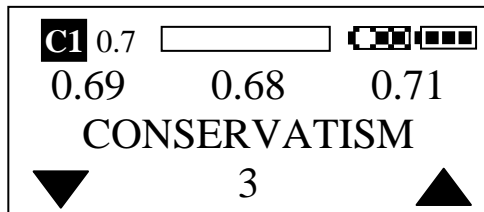

The Conservatism level is adjustable from 1 to 5, level 1 is the least conservative setting, level 2 is generally the same decompression time as level 1 but specifies a slightly deeper first stop. Level 3 is more conservative than 1, level 4 is the same as 3 but specifies a slightly deeper first stop. Level 5 specifies extra conservatism and deeper first stop.



WARNING: The conservatism settings **MUST** be checked by **YOU** prior to **EVERY** dive.

8.2.4 Depth Units

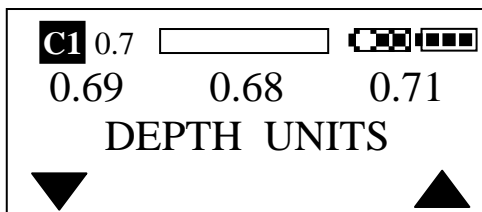

Select the centre switch to change the depth units.

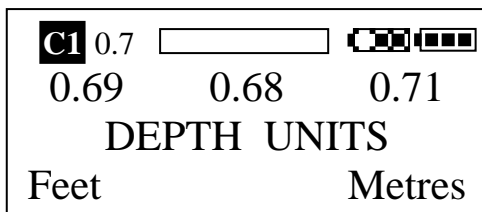

Select metres or feet.

8.2.5 Time and setting

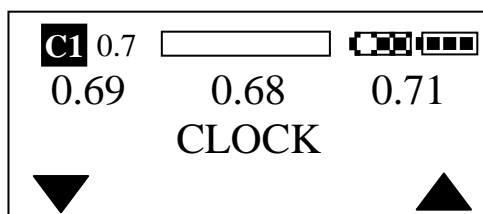

The electronics has a real time clock and this can be adjusted to match your local time and date.

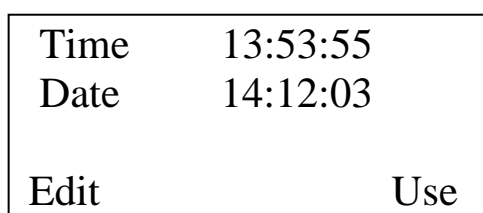

The current set time and date is shown. Select Use to leave the settings as they are.

Time 13:53:58
 Date 14:12:03
 Set - HOURS

On selecting Edit, the first option is to change the time, starting with “Hours”. Press the up and down arrows to make the change and then confirm with the Centre switch.

Time 13:53:58
 Date 14:12:03
 Set - MINUTES

Following through, the Minutes, Seconds, Day, Month and Year can be altered.
 The Date format is fixed at the European format: Days:Month:Years.

NOTE: When a battery is changed, the clock and date information will be lost if not replaced within 4 hours. If this occurs, at start up in between the front end splash screens, you will be prompted to enter the date and time as above.

TIME AND DATE
 INVALID
 ADJUST NOW!
 ↓

Time 13:53:58
 Date 14:12:03
 Set - HOURS

Tip: Use the APD Communicator software and Bridge Interface to synchronise the date and time with your PC.

Note: It is normal for the PC clock and VISION electronics clock to vary from each other, sometimes as much as 10 secs per day. Synchronise the clock and date feature using the APD Communicator, every time you download your dives.

8.2.6 Dive Log

C1 0.7 
 0.69 0.68 0.71
 DIVE LOG

Press the centre switch to enter Dive Log. Scroll through dives using the arrows to see the dive No. on the top line, the date (dd/mm/yy) and dive duration (mins/secs), on the 2nd line, time of entry(hrs/mins/secs) and maximum depth (metres or feet) on the third line. This data is stored for 48 dives. The dive No. is incremented by one every time the rebreather descends below 1.2m providing the surface interval is greater than 5 mins. If the surface interval is less than 5 mins it is counted as the same dive. Press the centre switch to exit Dive Log. The dive end is logged when the handset is at approx. 0.9m (3ft) or shallower.

DIVE 00125
 14:12:03 75:25
 13:53:27 37.3m
 EXIT

8.2.7 Oxygen Exposure %

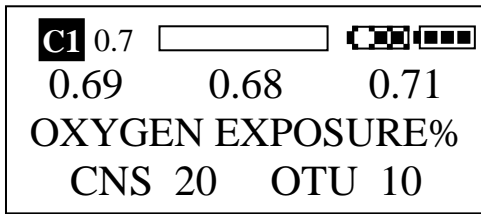

Both the CNS and OTU are tracked and displayed in the DECO menu.

8.2.8 Demo Mode

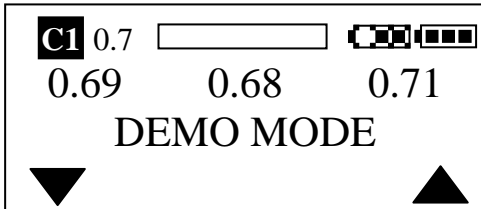

Demo mode can be run for tuition purposes to show some of the underwater displays and underwater menus.

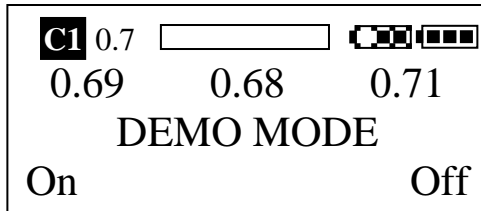

On pressing the centre switch the option to turn the Demo Mode on or off is given. Select On and then arrow down to "Exit Menu" or just wait for 15 secs.

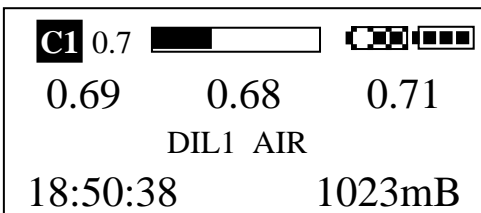

NOTE: When in demo mode the Scrubber monitor scrolls to indicate it is in dive mode. The left switch does not call up the Slave display (whilst in demo mode). The setpoint is automatically set at 0.21 bar and the Low Oxygen warning is set at 0.16 bar.

NOTE: press the left switch to descend or the right switch to ascend.

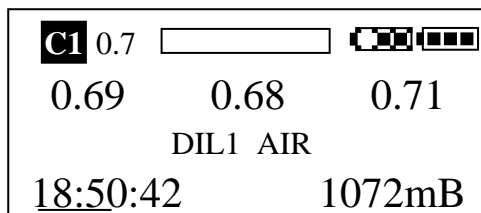

The pressure can be seen to increase as the left switch is held.

The following displays are for the Decompression Option. If the depth and dive timer option has been purchased there will no "No Stop Time", "Total Time to Surface" or "Ceiling" displays.

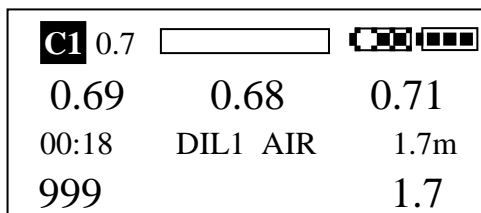

Once the pressure is equivalent to approximately 1.2m (4ft) the display enters the underwater mode.

C1 0.7		
0.69	0.68	0.71
00:40	DIL1 AIR	21.7m
999		15.4

Press the left switch to descend and the right switch to ascend.

C1 1.30		
0.69	0.68	0.71
03:53	DIL1 AIR	30.2m
24		30.2

If AUTO Setpoint switch is selected; once the depth increases deeper than the switch depth, the HIGH setpoint becomes active and the No Stop time can be seen to increase. If a Decompression option has been purchased the No-Stop Time is displayed in the bottom left hand corner.

C1 1.30		
0.69	0.68	0.71
59:10	DIL1 AIR	30.2m
10 TTS	4.0	30.2

Once the No-stop time reaches zero, the display changes to Total Time to Surface (TTS) (10 mins in this example, along with a ceiling of 4.0m)

C1 1.30		
0.69	0.68	0.71
62:02	DIL1 AIR	30.2m
8 TTS	3.0	6.1

Ascend by pressing or pressing and holding (to ascend faster) the right hand switch. In this example the depth is shown as 6.1m, the TTS as 8 mins and ceiling as 3m.

C1 0.70		
0.69	0.68	0.71
70:25	DIL1 AIR	30.2m
999		2.8m

Ascending further, once the depth reaches the 100% O₂ depth the setpoint is set to switch to the LOW setpoint, providing the AUTO setpoint option is selected.

8.2.9 Demo Mode – “Underwater”- Menu

Whilst the display is in mock underwater mode during a Demo, the underwater menu may be accessed in the normal way, by pressing the left and right switches simultaneously. The Menu options are the same as the normal underwater menus (Section 8.3) with the exception of an additional screen at the start giving the option to turn the Demo Mode off.

If the Nitrox or Trimix versions have been purchased the diluents and setpoints may be changed, and its effect on Deco can be seen.

NOTE: Any changes made during Demo Mode are cancelled as soon as Demo Mode is exited.

8.2.10 Demo Mode - Surface Interval Display

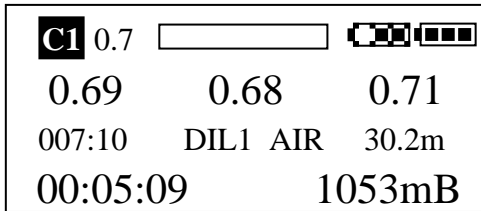

Once the depth is shallower than approximately 1.2m (4ft) the display changes to show the dive duration, max. Depth and a surface interval timer (hours:mins:secs) is started.

At this stage, pressing the left or right switches still has control over the pressure display in the bottom right corner. To switch the Demo mode off, either enter the Menu mode again (pressing the left and right switches simultaneously) and then scroll down and select Demo Mode OFF. Alternatively, just shut down the electronics (see 10.1), when you fire up again the Demo Mode will be disabled. If you physically go underwater with it in Demo Mode, at 1.2m(4ft) the electronics goes straight into Dive Mode and turns off Demo Mode.

8.2.11 Exit Menu

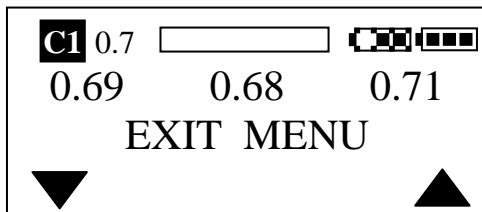

Exit the DECO Menu by pressing the centre switch or just wait for 15 secs and it will exit itself.

8.3 Menu Mode - Underwater

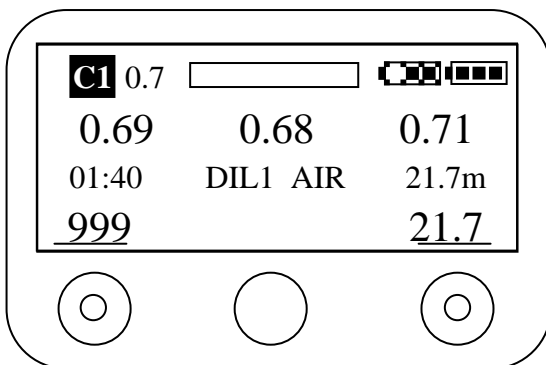

Press the outside two switches, simultaneously or within 0.5sec of each other, to enter MENU Mode.

Tip: If one option needs to be changed, change it and then wait. After 15 secs the display reverts back to the Dive Mode display above.

8.3.1 Open Circuit Decompression (Not available in Dive Timer version)

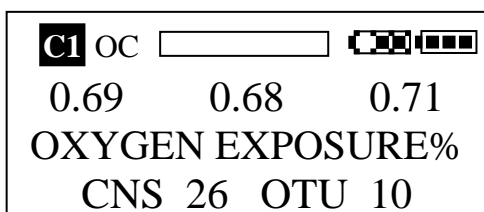
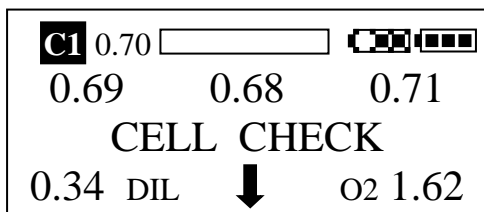
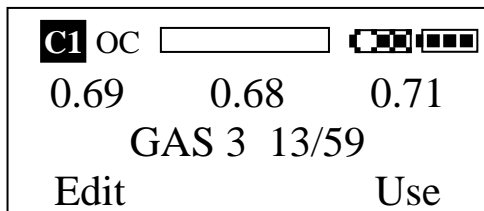
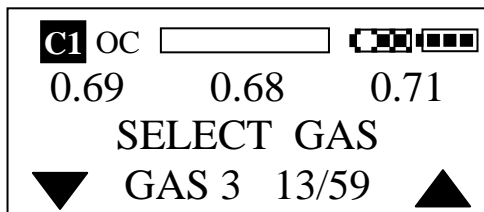
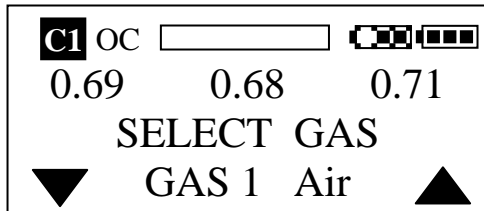
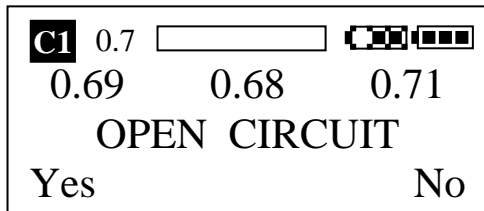

In all version except Dive Timer the first screen displayed in the underwater menu is an option to switch to Open Circuit Decompression.

If Yes is selected the diver is then prompted to choose the Gas used on open circuit.

In Recreational 1 no gas choice is offered, it is assumed the diver is using air. In Recreational 2, there are 2 gas choices available, one would normally be set to air, the other to the bailout gas which can be set at 21 to 40% O₂.

In Nitrox and Trimix versions there are 6 gas choices.

If NO is selected then the Open Circuit decompression is switched OFF and the next Menu option, "Change Diluent?" or "Cell Check" is displayed.

Once Open Circuit Mode is selected the Diluent is called "Gas" and "OC", for "Open Circuit" is displayed in place of the setpoint.

NOTE: Diluents 1 to 6 are the same as Gas 1 to Gas 6

Once the required gas is displayed, confirm by pressing the Centre switch.

The option to "Edit" the gas or "Use" the gas is given. Helium % may only be entered if the diver has purchased the Trimix decompression option.

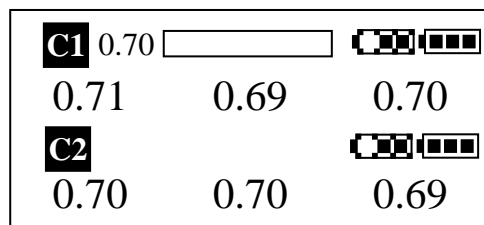
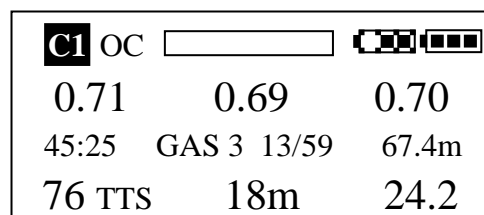
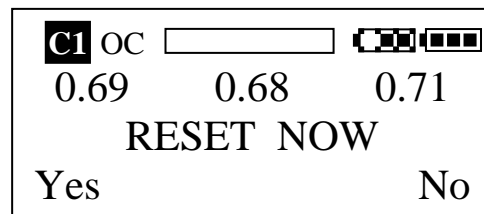
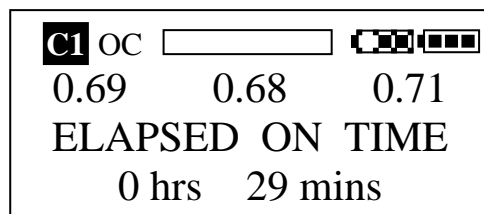
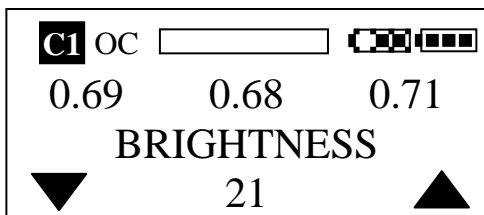
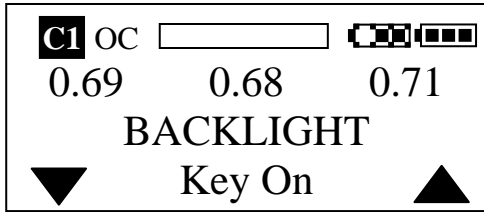
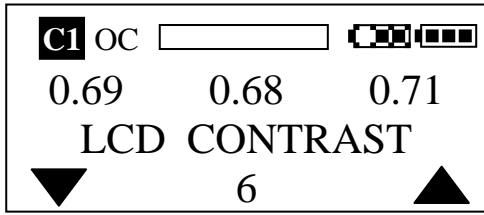
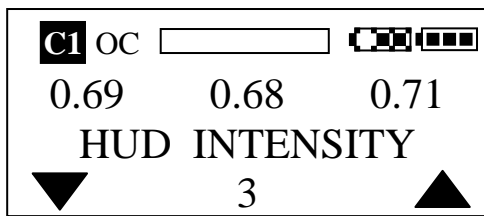

Back in Dive Mode, OC is seen displayed in place of the setpoint.

IMPORTANT: On firmware version 05.01.00 onwards, when Open Circuit Bailout Mode is selected, the Master oxygen controller will automatically switch to the low setpoint and try and maintain it, this is to make buoyancy control easier during the ascent. If the left switch is pressed and held for 2 secs the Slave controller will be displayed and at the same time the OC changes to display, momentarily, the setpoint. To change the setpoint simply press and hold the centre switch for 3 secs plus.



WARNING! On previous firmware versions, if you are on open circuit and the rebreather is still on the high setpoint the ascent may be difficult to control due to the extra oxygen addition to the loop. Simply switch to the low setpoint by pressing and holding the centre switch for 3 secs or simply close the oxygen cylinder valve (remember to open it again once the “exercise” is over).

8.3.2 Change Diluent

C1	0.70	<input type="text"/>	
0.69	0.68	0.71	
OPEN CIRCUIT			
Yes		No	



C1	0.70	<input type="text"/>	
0.69	0.68	0.71	
CHANGE DILUENT			
Yes		No	

CHANGE DILUENT is a closed circuit option and is displayed if a “No” response is given to “OPEN CIRCUIT”

C1	0.70	<input type="text"/>	
0.69	0.68	0.71	
SELECT DILUENT			
▼	GAS 1 Air		▲

Scroll down or up to reach your pre-defined gas

C1	0.70	<input type="text"/>	
0.69	0.68	0.71	
SELECT DILUENT			
▼	GAS 3 13/59		▲

Select the gas by pressing the centre switch



C1	0.70	<input type="text"/>	
0.69	0.68	0.71	
DILUENT 3 13/59			
Edit		Use	

To modify the gas, select Edit.
To select the gas, select Use.

NOTE: **Recreational 1** – no option to change from air

Recreational 2 – two gases, 21-40% O₂, use gas 1 air diluent (21% O₂) and gas 2 use for OC bailout deco gas 21-40% O₂.

Nitrox – 6 gases, 20-100% O₂, use gas 1 air diluent and gases 2 to 6 for OC bailout deco gases.

Trimix – 6 gases, 5-100% O₂, 0-95% Helium, typically use gas 1 for air diluent, 2 and 3 for different bottom mixes, gas 4 as 1st bailout gas and 5 and 6 as 2nd and 3rd bailout gases.

NOTE: All gases are set to air when the new product is shipped from the factory. Once you set the gases to your selection they will stay on your selection.

8.3.3 Cell Check

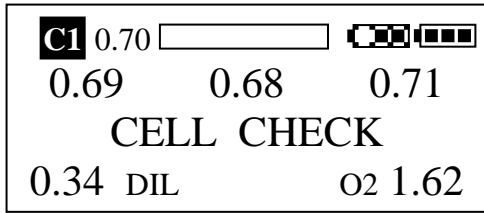

The Cell Check Screen shows what the PPO₂ displays should be, if the loop is flushed properly at the current depth with diluent or oxygen. Cell Check is displayed for 15 secs. If a switch is not selected within 15 secs the display will revert to Dive mode display.

NOTE: If the Cell Check display is required for longer than 15 secs, simply press either the left

or right switch to extend the Cell Check display for a further 15 secs. If the centre switch is pressed then the display moves onto the next underwater option: High Setpoint adjustment.



WARNING! Be sure that the gas you flush the loop with is respirable (i.e. life supporting) BEFORE flushing. This applies equally to diluent in the shallows as oxygen when deeper than 6m.

NOTE: the highest displayable value on the bottom line of the Cell Check display is 9.99 bar. However, the highest ppO₂ displayable on the three cells is only 2.55 bar.

8.3.4 Additional Underwater Menu Displays/Options - CCR

Additional CCR Menu Options are only available when underwater IF the centre switch is chosen at “Cell Check”.

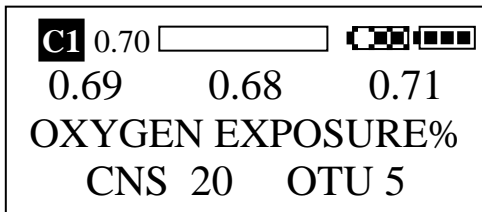

See Section 8.1 – Surface Menu Options for screen explanations.

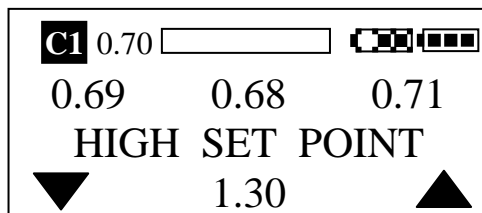

Not available in Recreational 1 and 2 versions

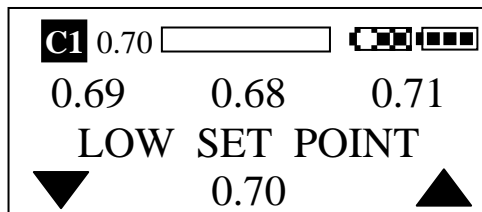

Not available in Recreational 1 and 2 versions

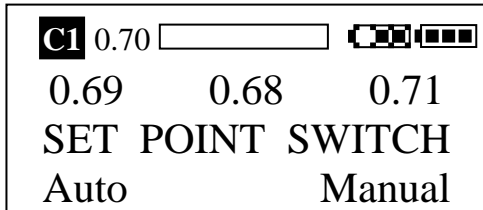

Not available in Recreational 1 and 2 versions

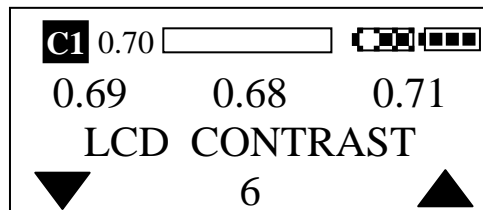
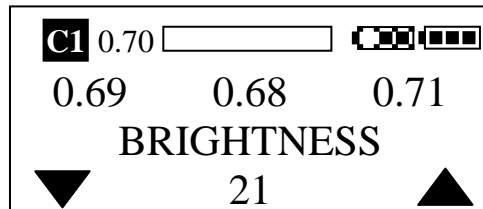
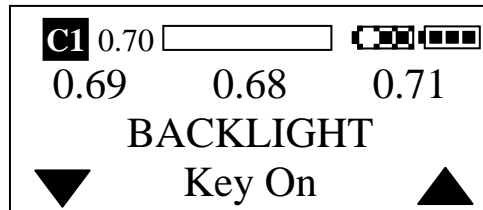
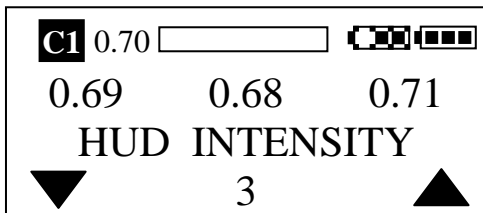

Not available underwater in Recreational 1 and 2 versions

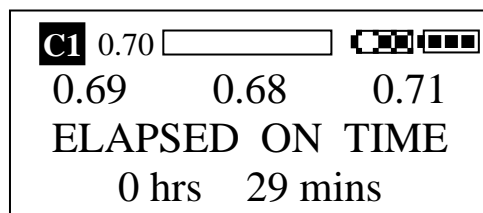

Not available in Recreational 1 and 2 versions

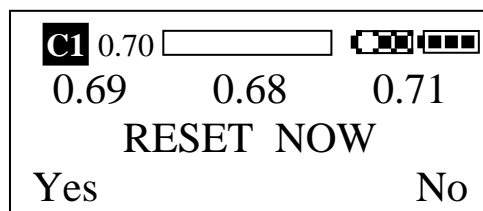

Not available in Recreational 1 and 2 versions

SECTION 9

9.0 WARNINGS AND REMEDIES

9.1 Pressure Sensor Warning

The pressure sensor warning will appear if the pressure sensor has failed prior to or during the dive. If the sensor fails before the electronics are switched on the warning screen will be displayed after the initial splash screen.



If YES is selected the unit forces dive timer mode to prevent any decompression calculations.

During the Calibration phase the ambient pressure must be set manually.



If the pressure sensor fails during the dive, a general alarm is set on the HUD (solid RED LED's), the buzzer will sound and the screen error message "FAILED PRESSURE SENSOR" appears.

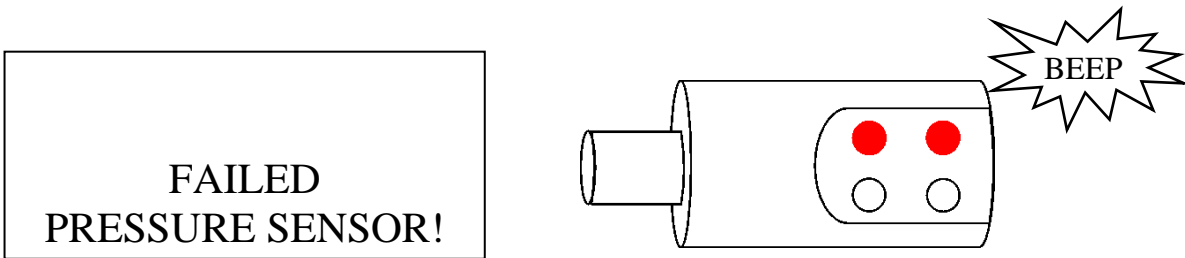

The error message is suppressible and clears the error indefinitely. However if the fault is intermittent and the pressure sensor recovers so that at least 1 averaged measurement has been made (8 pressure readings + 1 temperature reading) and the sensor then fails again it will set the error flag again and will require re-suppressing. The decompression information will be frozen (either the NST or the TTS and Ceiling). The depth freezes and all decompression calculations stop. The dive time continues to count up.

9.2 Low Oxygen Warning

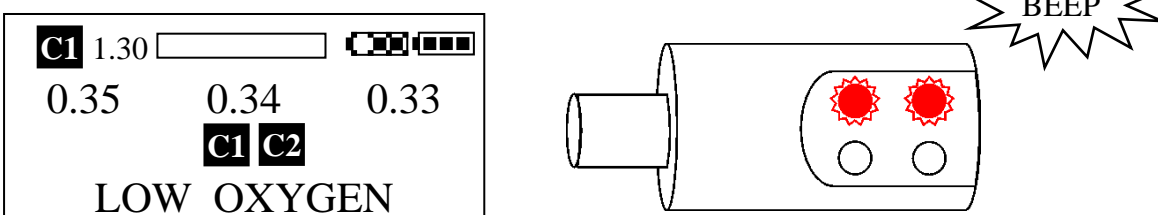

The LOW OXYGEN warning is activated when the ppO₂ drops to 0.4 bar or below. One or both red lights flash **slowly**, the buzzer sounds and “LOW OXYGEN” is displayed alternating with ppO₂, depth and dive time information. The warnings will continue until the ppO₂ rises above 0.4 bar. In dive mode at the surface, this can be tested by flushing the loop with diluent forcing the ppO₂ below 0.4 bar. The warning will be displayed and the buzzer activated until the oxygen controller returns the ppO₂ to above 0.4 bar.

Actions to take when LOW OXYGEN is displayed and buzzer sounds:

Low oxygen can occur for a number of reasons. The most likely cause is that the oxygen cylinder valve is closed. The oxygen contents gauge will register empty if that is the case. Simply opening the valve may cure the problem. A second possibility is that all the oxygen has been consumed - check the pressure gauge. If the pressure gauge shows empty and the cylinder valve is definitely open, injecting diluent into the loop will rapidly bring the ppO₂ up to reasonable levels. Providing you are not using an hypoxic diluent in the shallows. It is easy to flush the loop with diluent by pressing the diluent inflator at the same time as pulling the exhaust valve’s dump knob.

If there is oxygen in the cylinder but it is not being supplied to the loop by the oxygen controller and solenoid, the best way to increase the ppO₂ is to use the oxygen inflator located on the exhale counterlung.

If this situation arises do not panic - there is sufficient time to recover the situation. **MOST IMPORTANTLY** you should NOT ascend immediately. During ascent the ppO₂ in the loop will drop extremely quickly. Ascent from 30 m straight to the surface, starting with only 0.4 bar in the loop would result in unconsciousness before reaching the surface!

Low Oxygen Warning Suppression

The Low Oxygen Warning may NOT be suppressed in the same way a Battery or Cell Warning can be. The Low Oxygen Warning will remain until the ppO₂ is increased above 0.4 bar.

9.3 High Oxygen Warning

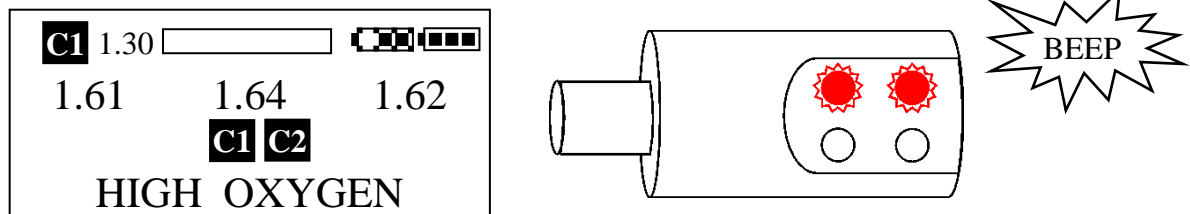

The HIGH OXYGEN warning is set at 1.6 bar. One or both red lights flash **quickly**, the buzzer sounds and “HIGH OXYGEN” is displayed alternating with ppO₂, depth and dive time information. The warnings will continue until the ppO₂ drops below 1.6 bar.

Actions to take when the HIGH OXYGEN warning is displayed

Look at the display to assess whether the ppO₂ has momentarily spiked because the descent was too rapid, or if the ppO₂ is climbing rapidly. If it is climbing rapidly, close the oxygen cylinder valve and flush the loop with diluent to reduce the ppO₂, by operating the pull cord dump valve and the diluent inflator simultaneously, and then breathe again. Ensure you are pressing the diluent inflator on the left counterlung and not the oxygen inflator on the right! When reopening the cylinder valve observe the ppO₂. If it climbs rapidly again, it is possible that the solenoid valve is jammed open and the oxygen cylinder valve must be closed again. Open and close the valve in short bursts to manually control the ppO₂. When deeper than 20m too much O₂ may be added using this method unless the diver is well practised and the alternative of adding diluent to maintain the ppO₂ should be considered.

The rebreather may be used in this manner for as long as necessary but open circuit bailout should be considered.

It is advisable to only open the oxygen cylinder valve by one or two turns. It can then be closed quickly if required. However, if you breathe from this cylinder via the open circuit 2nd stage at 6m and shallower, higher gas flows will be required and the valve will need to be opened more fully.

High Oxygen Warning Suppression

The High Oxygen Warning may NOT be suppressed in the same way a Battery or Cell Warning can be. The High Oxygen Warning will remain until the ppO_2 is reduced below 1.6 bar.

9.4 Open Circuit Oxygen Warnings

If the diver switches the handset to Open Circuit the assumption is made that the diver has in fact reverted to open circuit. The green LEDs are switched off. Any High or Low Oxygen warnings on the LOOP (the rebreather's breathing circuit) will be displayed on the handset as normal, but NOT ON THE HUDs or buzzer!

The HUD and buzzer will be dedicated to show extreme Open Circuit oxygen conditions.

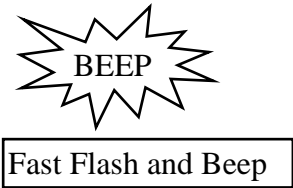
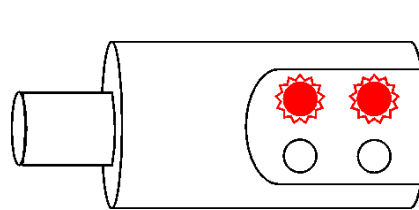
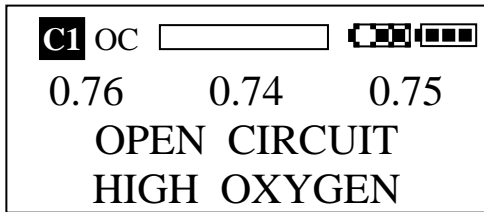

For instance, if you choose an open circuit gas with a ppO_2 greater than 1.6 bar then OPEN CIRCUIT HIGH OXYGEN will be displayed on the handset and HUDs. Similarly, if the gas selected is hypoxic at the current depth (less than 0.2 bar) the OPEN CIRCUIT LOW OXYGEN will be displayed on the handset and HUD

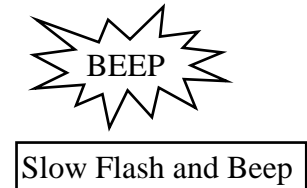
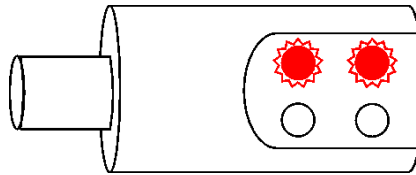
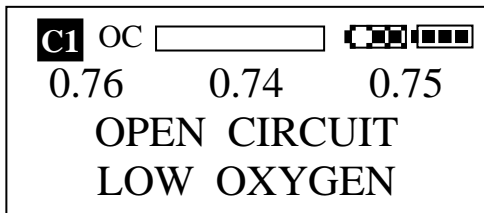

WARNING: If you make the mistake of breathing an hypoxic (low oxygen percentage) gas in the shallows – this warning MAY NOT save you. You are most likely to lose consciousness and be unable to effect self-help.

9.5 Cell warning

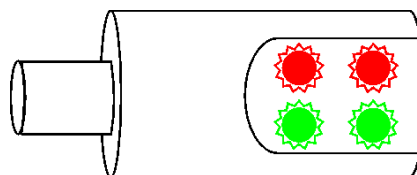
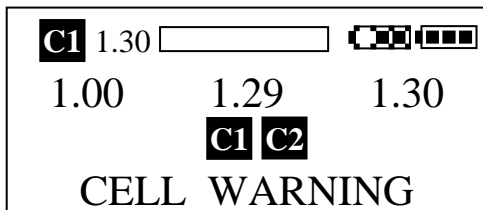

A CELL WARNING occurs if one cell deviates from the average of the closest two by more than 0.2 bar.

Actions to take when the CELL WARNING is displayed

The first task is to check the displays for both controllers. Bring up the Slave's display by pressing and holding the left switch.

C1	1.30		
	0.00	1.29	1.30
C2			
	0.00	1.29	1.30

In this case the problem is seen by both controllers, which indicates a faulty cell connection or faulty cell.

At this point you have to make the decision whether to continue with the dive or to abort the dive. If aborting the dive, the next task is to decide whether to stay on the rebreather or bail out to open circuit. Tip: if in doubt, bail out to Open Circuit. A safe alternative is to do a diluent flush. This places fresh respirable gas in the loop and gives an opportunity to see which displays are changing values, reflecting the changing ppO₂. After this oxygen will normally be added to the loop by the oxygen controller. Be wary of any cells that seem to reach a ceiling while the oxygen solenoid is open. If the solenoid is open and a cell value rises, then that is a good cell.

Cell Warning Suppression

If you decide to stay on the rebreather the CELL WARNING may be temporarily suppressed by pressing and holding the right switch for 2 secs plus. The HUD and buzzer warnings will then be suppressed, leaving the wrist display showing the CELL WARNING.

9.6 Low Battery Warning

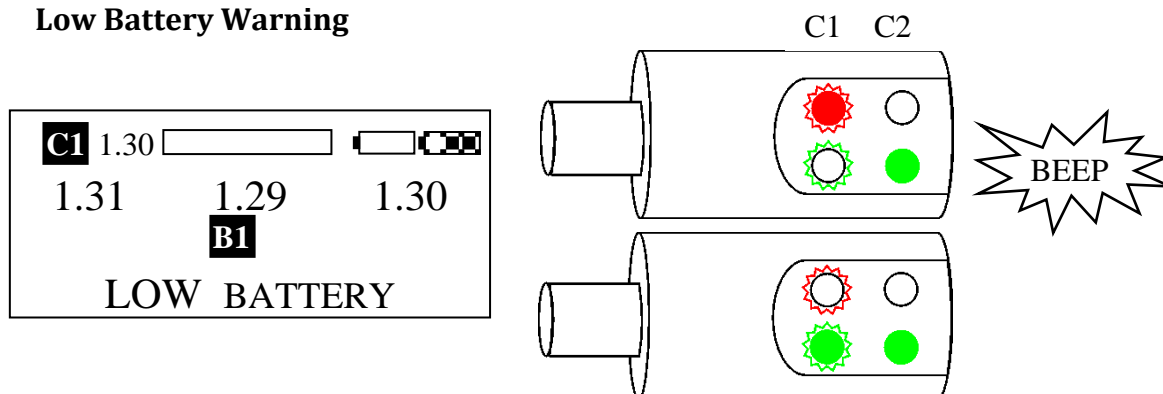

A low battery warning is indicated by alternating red/green/red/green etc flashing lights in C1 or C2 or both if both have low battery levels.

In the example above C1's HUD is indicating a low battery and this is confirmed in the display. When the B1 batteries hits its LOW Battery threshold B2 is automatically promoted to Master status and B2 is then used to supply power to the wrist mounted display and solenoid. B2 can be seen to be highlighted indicating it is already at Master status.

Actions to take when the LOW BATTERY warning is displayed:

The best battery management technique is to simply throw away B1 when it gets to the Low Battery Warning. Take B2 from its slot and insert into the B1 compartment. Then insert new batteries into B2. This way you always have a relatively fresh battery in the B2 slot, effectively in reserve. Providing this technique is adopted it is quite in order just to finish the dive and change the batteries using the above system prior to the next dive. B1 is the battery compartment closest to the solenoid.

Battery Warning Suppression

If you decide to stay on the rebreather the LOW BATTERY warning may be temporarily suppressed by pressing and holding the right switch for 2 secs plus. The HUD and buzzer warnings will then be suppressed, leaving the wrist display showing the Battery Warning.

9.7 Dive Start Error!

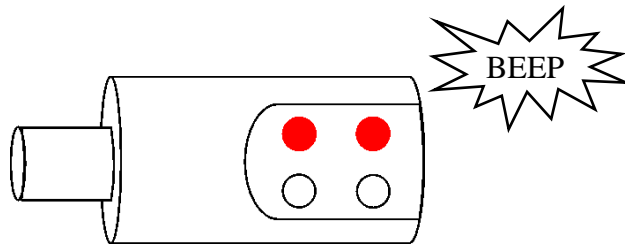
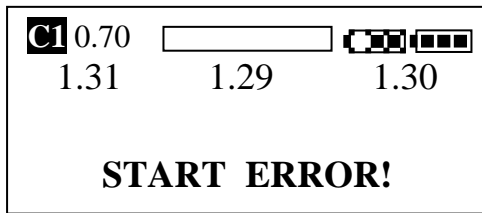

If the electronics are switched on and the pre-dive sequence is not completed and the diver enters the water, once below 1.2m(4ft) the dive Start Error will be displayed.

This warning can be suppressed by pressing the right switch for 2 secs plus. The display will then revert to normal underwater Dive Mode with the Low setpoint selected. The dive may be continued at this stage providing the diver is satisfied with not carrying out a calibration. The advice is to return to the surface, get out and calibrate the rebreather prior to further use.

9.8 CO₂ Scrubber Warning!

If purchased, the centre rod of the scrubber is replaced with a similar “moulded” rod which houses an array of digital temperature sensors – a Temp-Stik. This allows the monitoring and display of the most active region of the scrubber material. The Temp-Stik is distinguishable by the fact that it has a connectorised cable protruding into the lid area.

There are two levels of Scrubber warning given by the Scrubber monitor system:

The first warning is given when only one segment on the right side of the scrubber monitor is shown as being active. See Section 4.14. This warning is suppressible by pressing and holding the right switch for 2 secs plus. **(but the dive should be terminated !)**

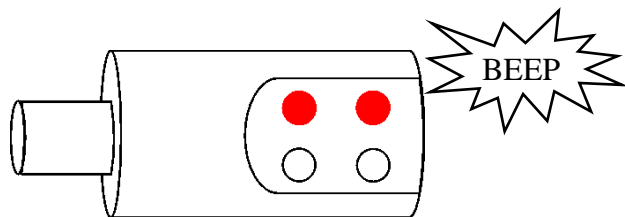
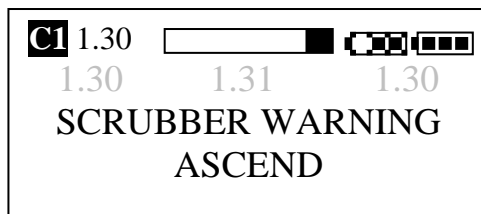

The final scrubber warning is given when the active area of the scrubber is too small to remove the CO₂ effectively. This is shown on the scrubber monitor as a blank screen. The warning is not suppressible. You must ascend and revert to open circuit bailout.

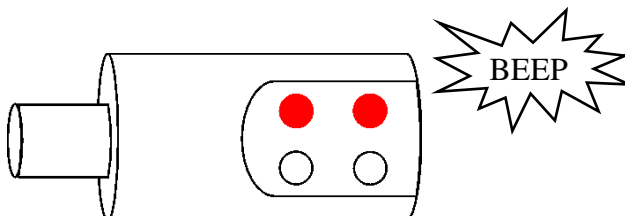
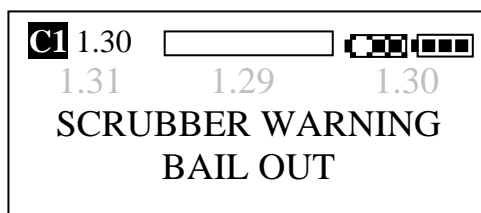

NOTE: The Scrubber warning system does not measure CO₂, it monitors scrubber activity by measuring the temperature throughout the Sofnolime bed.

When activated ascend immediately and consider using open circuit bailout.

NOTE: This system looks not only at the active area of CO₂ absorbent; it also looks for abnormal temperature profiles. A warning may be given when CO₂ is channelling through the bed. This warning though may prove to be too late for some individuals. This system is NOT a CO₂ detector or sensor!

In all cases, if the scrubber warning is activated whilst underwater the **ONLY** cure is to ascend and revert to Open Circuit bailout.



WARNING: Be aware that CO₂ symptoms may be masked when breathing a high ppO₂ mixture (0.7 bar is regarded as high in this context). **IF IN DOUBT BAIL OUT!**

9.9 Oxygen Toxicity Warnings

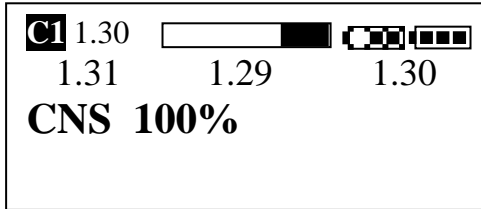

The oxygen toxicity warnings are raised at 100% of the NOAA levels, see 3.5.5

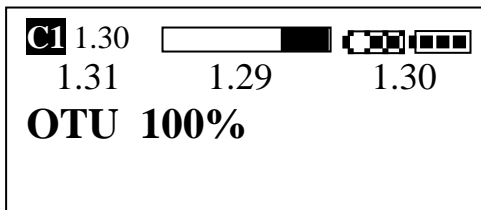

A daily OTU limit of 300 is used for the 100% indicator. A warning is raised at 100% of 300, see 3.5.6

9.10 Ascent Speed Warning

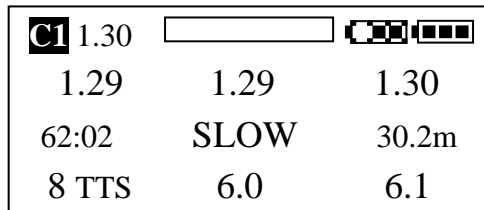

If an ascent speed of 10m/min is violated, SLOW is flashed on the centre line of the display.

9.11 Ceiling Violation (decompression versions only)

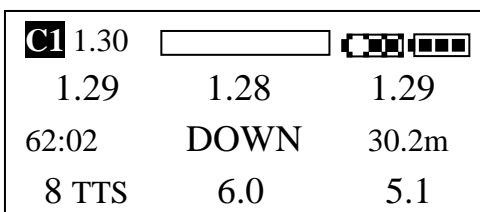

In this example the ceiling is 6.0m, but the diver has ascended to 5.1m, resulting in “DOWN” and down pointing arrows being displayed alternately on the lower-centre line.

Additionally a red light is shown on each controller’s HUD and the audible alarm is sounded.

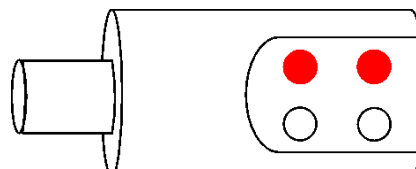
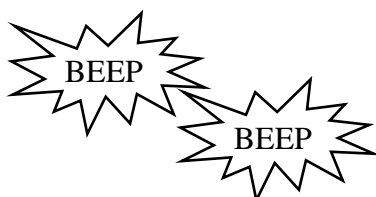
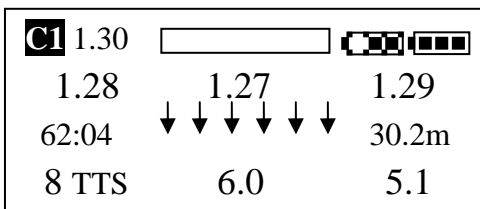

9.12 Slave Oxygen Controller Promotion to Master

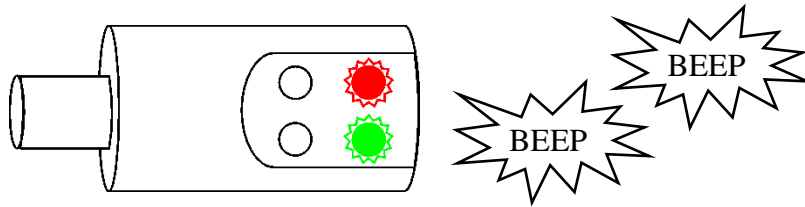

The Slave Controller's job is to monitor the Master controller. If the Master controller stops signalling to the Slave that it is active the Slave will automatically promote itself to Master status taking over the control of the oxygen solenoid. (If the power to the Master failed there would be no HUD for that controller; switching off C1 easily simulates this; C2 will promote itself and be displayed in the top left corner of the display. When C2 is being promoted to Master Controller the HUD will give a double Red/Green flash and the buzzer will give a double beep audible alarm.

9.13 Setpoint Switch Alert

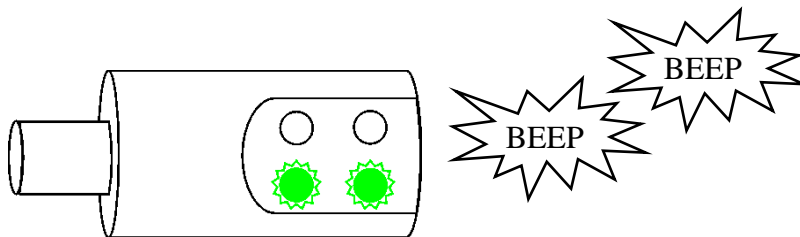

When the setpoint changes from high to low the HUD will give a double Green flash and the buzzer will give a double beep audible alarm.

9.14 Error Priority

Errors are displayed on the lower two lines of the screen and are cycled with the dive time and depth information. If more than one fault exists the wrist display will sequence through showing all warnings. However, the Head Up Display will only display one warning, the one with the highest priority.

Red Lights (High O₂, Low O₂, Look at the wrist display) are High Priority Warnings and will take precedence over Red & Green (low battery, cell warning) or Green (flashing - ppO₂ dropped 0.2 bar below setpoint, solid-normal dive mode). A Flashing Red (High O₂, Low O₂) is high priority and takes precedence over a still Red (Look at the screen).

SECTION 10

10.0 POWER CONTROL

10.1 Power Shutdown

The Power Control screen may be entered at any time, from any screen by pressing centre and right switches simultaneously: The Power Control allows the shutdown of either of the controllers or the whole system, except when underwater: Whilst underwater you cannot turn off the entire system, the ALL OFF option shown at the surface becomes NONE OFF. If one controller is switched off it may be switched on again using the same power control screen:

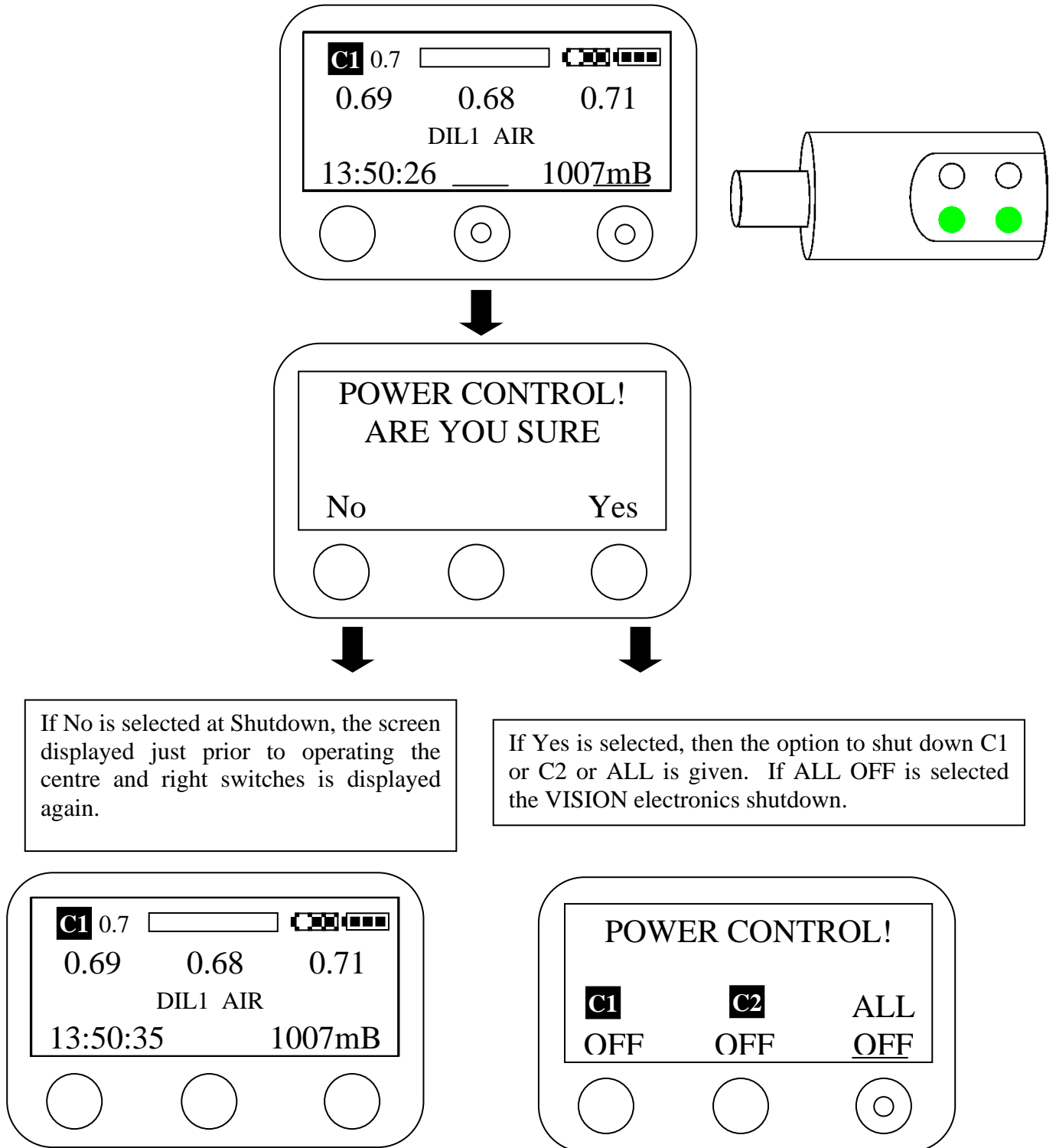

10.2 Promoting Slave Controller to Master

The Slave will promote itself to Master controller AUTOMATICALLY should the Master drop its “Master Status Flag”. This could occur for example due to an intermittent power supply to the Master Controller or the Master’s processor fail for some other reason.

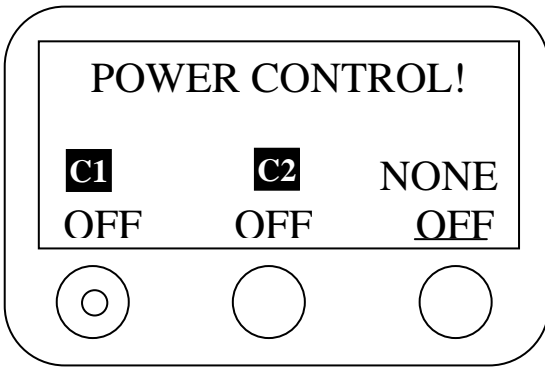

NOTE: “NONE OFF” is displayed in place of “ALL OFF” when underwater.

However, it is possible to force the Slave to promote itself to Master and this is achieved by simply switching off the original Master, i.e. If C1 is Master, switch it off! – C2 will then become Master and be displayed on the top line of the display.

NOTE: the HUD lights do NOT change position. C1 is always on the left, C2 is always on the right – if you want to know which controller is Master, you have to look at the wrist mounted display.

If you then press the left switch, holding it for 2 secs, the Slave’s ppO₂ and battery levels will be shown:

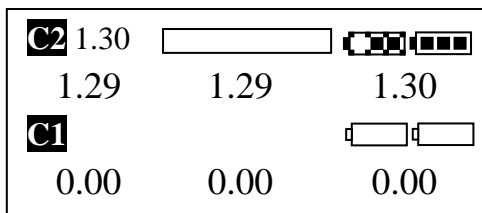

As it has been turned off zero ppO₂ readings, along with empty battery boxes, are shown for the Slave, C1.

10.3 Reinstating a switched off Slave Controller

If the Shutdown is selected again, by pressing the centre and right switches the following display appears:

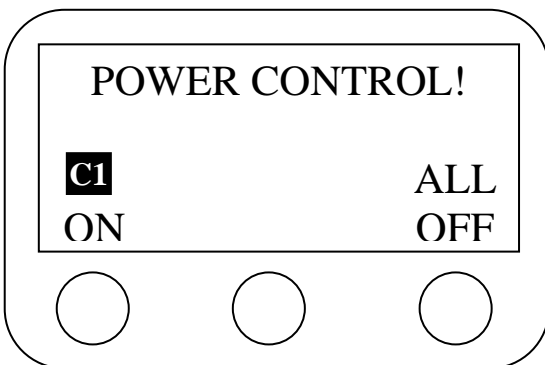

Here the option is given to either switch off completely by selecting ALL or switch on C1.

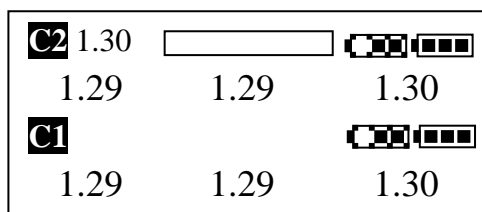

If Switch on C1 is selected it comes on as Slave and can be seen by pressing, & holding the left switch for 2 secs.

SECTION 11

11.0 DECOMPRESSION

11.1 Gas Selection

Before conducting each dive, ensure the decompression settings in the DECO menu are appropriate for the planned dive: YOU need to select the correct diluent and suitable Gradient Factor or Conservatism setting. Up to 12 diluents may be entered. If the switch is made to Open Circuit the 12 diluents are then available, for decompression calculation purposes, as Open Circuit gasses.

On delivery the 12 gasses programmed in, on the Trimix version, are:

	TRIMIX	NITROX
Diluent 1	Air	Air
Diluent 2	16/44	32% Nitrox
Diluent 3	13/59	36% Nitrox
Diluent 4	10/52	40% Nitrox
Diluent 5	36% Nitrox	50% Nitrox
Diluent 6	80% Nitrox	80% Nitrox
Diluents 7 -12	Air	Air

All 12 gasses are user definable and may be edited. Once edited, the gasses remain on your chosen settings.

All 12 gasses can be called up underwater as closed circuit diluents or open circuit gasses. All 12 gasses may be edited underwater if necessary.



WARNING! Open circuit bailout planning should be done prior to diving to ensure sufficient volumes of gas are carried.



WARNING! For the decompression to be valid, the correct diluent must be chosen.

The Decompression facility built into the Nitrox and Trimix versions of the VISION uses the same software as the APD Dive Planner program to calculate decompression requirements. This is not a look up table; this uses real time information from the pressure sensor and dive timer to provide continuous calculation for the decompression requirements based on the chosen diluent or gas if the open circuit deco option has been activated.

By using the APD Dive Planner, dive planning becomes much easier and backup tables are easily produced. The APD Dive Planner software is based on the Bühlmann ZHL16A-1b algorithm with gradient factor conservatism. It is intended to be used by divers as a supplemental aid to existing dive planning methods and software.

You must understand that all decompression products whether they be dive tables or dive computers are purely based on mathematical models and do not represent what is happening to your body. The reasons for DCS and the mechanism of on-gassing and off-gassing are not fully understood. There are some dive conditions where diving experts believe dive computers and decompression programs do not provide sufficient protection to the diver. These dives include: Saw-tooth profiles, Multiple dives in one day, Multiple days of diving and decompression dives where the diver may not return directly to the surface. Other than using gradient factors, there is NO additional built-in conservatism to the standard Bühlmann algorithm.



Use this decompression computer and APD Dive Planner software at your own risk.

People have experienced Decompression Illness (DCS commonly known as the ``bends") when diving to Bühlmann's tables (or with wrist-mounted computers which use Bühlmann's algorithm) and there are no guarantees that you won't get bent if you were to dive a profile which **the APD Dive Planner** generated, or if you followed the VISION's dive computer's guidelines.

If you do not fully understand the operation of the APD Dive Planner/VISION Decompression Computer and the implications of the various settings then **DO NOT USE** the APD Dive Planner or VISION Decompression computer. Using the APD Dive Planner or the VISION decompression computer does not guarantee a DCS free dive.

Higher Risk Dive Profiles include but are not limited to yo-yo (up,down,up,down) profiles, multiple dives in one day, multiple days diving. The understanding of the problems associated with these profiles is not fully understood even by the latest generation of decompression experts but are believed to place the diver at a higher risk of DCS. The VISION's decompression calculator makes no adjustments for these profiles.

The VISIONs decompression calculator does impose more decompression, if the ascent rate exceeds 10 metres/min and/or the ceiling is violated.

Should the diver go beyond the normal envelope of decompression calculation the VISION's decompression calculator will continue to display a best guess. This will be indicated by EST being displayed next to the Time to surface in place of "TTS". This can be seen in Demo mode by violating a decompression ceiling by more than one minute.

11.2 Gradient Factors (Trimix) and Conservatism Settings (Nitrox)

It is essential to apply Gradient factors to modify the ascent depending on gas mix used, bottom time and diving depth.

The following table represents gradient factors in common use for a variety of dives.

Depth	Bottom time (mins)	Gradient Factors: Low / High
0 – 40m (air diluent)		90/95
40 – 85m (Trimix diluent)	20	50/90
40 – 85m (Trimix diluent)	20 -60	15/85
85m -100m (Trimix dil.)	20	30/85
85m – 100m (Trimix dil.)	20-45	5/85

It is clear that Bühlmann models work in the air diving range and result in a low DCS incidence. (Note: the word "low" is used as opposed to "zero"!) Between 40m and 100m there are no validated decompression tables for Trimix and the % of dives that result in DCS is unknown. This is truly exploration diving ! When planning an "exploration dive" it is essential to make every effort to validate your planned decompression prior to the dive.



The Vision decompression calculations are invalid below 100m and must be regarded as "best guess" only.



The pressure transducer in the Vision electronics is only calibrated to 130m.

The following is a very simplified and abridged explanation of how the decompression calculations work and how they are affected by YOUR choice of settings.

The Bühlmann decompression model has 16 compartments, all with different half-times. The compartments do not represent body tissues but are simply a range of compartments which on gas and off-gas according to depth and time and at different rates according to their half-times in a crude attempt to simulate what is happening to the body tissues. Remember: Bühlmann is simply a mathematical model.

As you descend the ambient pressure increases causing the compartments to mathematically “on-gas”, all 16 at different speeds. Once a compartment reaches equilibrium with the ambient pressure it is said to be saturated. Any ascent then creates an over-pressure in that compartment compared to ambient and the new pressure gradient allows the compartment to off-gas. The amount of over-pressure allowed in any one compartment was determined by Bühlmann. Bühlmann’s figures however, resulted in a proportion of bends, so it is deemed appropriate to impose more decompression than Bühlmann first devised, bearing in mind all decompression models ever created result in a proportion of bends. By directly altering the amount of compartment over-pressure allowed it is possible to change the decompression profile to suit the individual’s tastes. If an over-pressure of 50% was used the allowed compartment over-pressure would be half of what Bühlmann allowed which would obviously result in more decompression than he devised. By using a different compartment over-pressure factor, or Gradient Factor, at the bottom to the one at the surface a decompression profile can be tailored to suit most divers’ requirements. By setting a gradient factor for the deepest part of the dive, called Gradient Factor Low, and another for the exit from the water, called Gradient Factor High, the compartment over-pressure allowed can be skewed to impose deeper stops, as well as ensuring the diver comes out of the water with less compartment over-pressure than Bühlmann thought acceptable.

Typically, Trimix divers use a High (or exit) Factor of 85% to exit from the water with a loading 85% of that devised by Bühlmann and a Low (or deep) Factor of 15%, which forces divers to do deeper stops. Just for purposes of explanation: if you selected a Low (deep) factor of 0% - you effectively wouldn’t allow any compartment over-pressure which would result in a phenomenally long decompression – which is why the Vision Dive Computer doesn’t allow 0%.

The Nitrox version uses Conservatism Settings 1 to 5, which are pre-programmed Gradient Factors. Simply, 1 is the quickest decompression, 5 is the slowest. None impose ultra deep stops, which are practiced for Trimix or Heliox dives. Conservatism setting 2 imposes a deeper first stop than 1, 3 has the same first stop as 1 but has a lower exit factor. Setting 4 imposes a deeper first stop than 3. 5 imposes both a lower exit factor and deeper first stop than any other 4 settings.

Conservatism Setting (Nitrox)	Pre-programmed GF Low	Pre-programmed GF High
1	90	95
2	75	95
3	90	90
4	75	90
5	75	85

11.3 Deep Stops

Sometime it seems there are nearly as many decompression theories as there are divers but the Deep Stop theory is currently widely accepted, but bear in mind this is based on anecdotal evidence rather than objective testing. It is said that “deep stops are good, but not for too long!”

The Bühlmann model has been used by more dive computers and by more divers than any other but still doesn’t guarantee that you won’t get decompression sickness.

Deep Stops are reputed to give a “cleaner” decompression resulting in less tiredness post-dive.

Deep Stops can be imposed on the Trimix version by simply using a Gradient Factor Low (or Deep) of around 5 to 15%. Use the Demo mode and the APD Dive Planner to explore the effects of different Gradient Factors and validate to known decompression tables prior to use.

11.4 Pre-dive - Surface

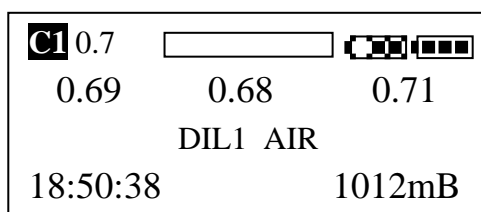

When this screen is displayed the rebreather is ready to dive.

11.5 Submerging

C1 0.7		
0.69	0.68	0.71
DIL1 AIR		
18:50:52	1064mB	

The ambient pressure display increases as the diver descends

C1 0.7		
0.69	0.68	0.71
00:18	DIL1 AIR	1.2m
999	1.2	

Once the pressure increases to the equivalent of approx.1.2m (4ft) the display changes to the underwater display. The dive and decompression information is displayed on the lower two lines.

11.6 Diluent Selection

C1 0.7		
0.69	0.68	0.71
00:18	DIL1 AIR	1.2m
999	1.2	

The diluent No. and description is shown on the third line. The diluent can be changed at any time, through the menu, to any of the other five stored diluents. At any time the diver may change the gas percentages of a particular diluent and this new gas will be stored for subsequent dives.

11.7 Dive Timer

C1 0.7		
0.69	0.68	0.71
00:18	DIL1 AIR	1.2m
999	1.2	

The dive's run time is shown on the third line, left hand side (in the format mins:secs). The dive timer starts when the handset, where the pressure sensor is, descends below approx. 1.2m (4ft). The dive timer stops when the handset ascends above 0.9m (3ft) the display changes to the Surface Interval screen.

11.8 No Stop Time

C1 0.7		
0.69	0.68	0.71
00:18	DIL1 AIR	1.2m
999	1.2	

When there are no letters after the time, the bottom left display is the No- Stop Time remaining. This starts at 999 mins and counts DOWN throughout the dive. The No-Stop Time is the time before decompression stops will be required during the ascent.

11.9 TTS - Total Time to Surface

C1 0.7		
0.69	0.68	0.71
62:02	DIL1 AIR	30.2m
8 TTS	3.0	6.1

Once the No Stop Time counts down to zero, TTS is displayed and the time then counts UP.

11.10 Ceiling

C1 0.7		
0.69	0.68	0.71
62:02	DIL1 AIR	30.2m
8 TTS	3.0	6.1

When TTS (Total Time to Surface) is shown, the ceiling is displayed on the bottom line. If you remained at depth, this number will increase. **YOU MUST NOT ASCEND ABOVE THE CEILING!**

11.11 Ceiling Violation

C1 1.30		
1.26	1.25	1.27
62:02	DOWN	30.2m
8 TTS	6.0	5.1

If you ascend above the ceiling, "DOWN" is displayed, the buzzer is sounded and the HUDs show red.

C1 1.30		
1.26	↓ ↓ ↓ ↓ ↓ ↓ ↓ ↓	1.27
62:03		30.2m
8 TTS	6.0	5.1

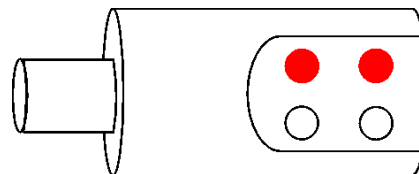
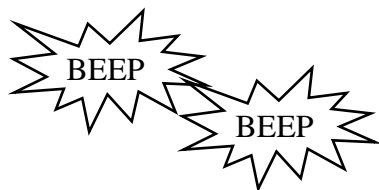

11.12 Estimated Decompression

C1 0.7		
0.69	0.68	0.71
62:02	DIL1 AIR	30.2m
8 EST	3.0	6.1

If the ceiling is violated the decompression required is increased. If the ceiling is exceeded for more than approx. 1 minute you have moved outside the normal decompression calculation envelope. At this juncture EST for ESTIMATE will be displayed instead of TTS (Total time to surface). It is highly recommended to decompress for longer than indicated in the bottom left corner of the display.

11.13 Fast Ascent

C1 1.30		
0.69	0.68	0.71
62:02	SLOW	30.2m
8 TTS	6.0	6.1

The standard Bühlmann ascent rate is 10m/min. If this is exceeded "SLOW" appears on the screen. To help control ascent speeds the depth is shown in increments of 0.1m or 1 ft. If the maximum ascent rate is exceeded then the decompression required is extended.

11.14 Surface Interval Display

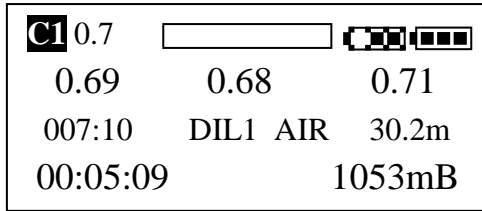

Once the depth is shallower than approximately 1.2m (4ft) the display changes to show the dive duration (in this example 7 mins:10 secs), max. Depth and a surface interval timer (hours:mins:secs) is started and showing in this example 5 mins and 9 secs.

11.15 Missed Deco !

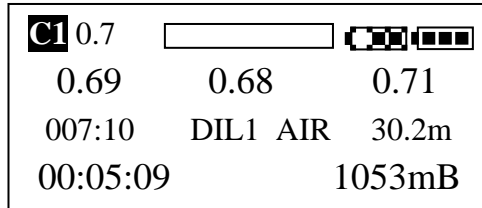

Missed Deco will be displayed on the screen if the diver surfaces without decompressing according to the dive computer. This is alternated with DOWN and the Surface Interval information.

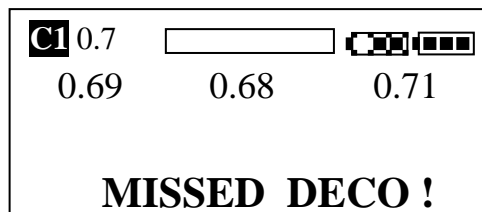

WARNING! In water re-compression is advised against if a recompression chamber with medically qualified staff is immediately available. The decision to descend after missing decompression though cannot be made for you here in this manual.

The decision whether to descend to re-compress or not depends on a lot of factors: How much decompression you missed, how rough the conditions are in terms of sea state and water temperature, how far away is the alternative choice – the recompression chamber, is there sufficient gas and personnel available to supervise in water recompression? These are just some of the questions that need answering before the decision can be made.

At the very least, the diver should be put on oxygen.

SECTION 12

12.0 PC CONNECTION

12.1 Standard equipment

Items supplied with every rebreather fitted with VISION electronics:

- a) Interface Bridge with serial connection to interface between the PC and the VISION electronics.
- b) A serial lead to connect the Interface to the PC
- c) USB/serial adaptor cable and driver software to replace the serial lead, for use on those PCs that don't have a serial port (typically laptops) or by those users who prefer the USB connection.
- d) APD LogViewer software for analysing and storing dives as an electronic rebreather logbook.
- e) APD Communicator Software for transferring files to and from the rebreather.
- f) Software upgrades are downloadable from the Ambient Pressure Diving website – www.apdiving.com

12.2 Terminology

Download – Data, programs or software keys are “downloaded” FROM either the internet or the VISION electronics TO the PC.

Upload – Data, programs or software keys are “uploaded” TO the VISION electronics FROM the PC.

To aid the understanding of upload/download, the direction of information is shown pictorially on the front screen of the APD Communicator program. The individual icons have colour graphics when the rebreather is connected to the Interface, switched on and the correct Com Port is selected.

Data – a) Dive data, including depth, dive time, and ppO₂ information may be downloaded and stored dive by dive as a log book record of the dive, with accumulated times.
b) Equipment configuration, service history data, and owner details are occasionally required and updated by factory personnel.

Software Keys – A unique key is generated to release, purchased, software options e.g. Nitrox or Trimix. This key is linked to the serial No. of your rebreather and is not transferable. Software keys are downloadable over the Internet.

12.3 Software

The APD LogViewer program is a logbook type program allowing you to store and view dive data for individual dives. The APD Communicator is used for both downloading data from the rebreather and for transferring (uploading) alternate language programs, updated programs software release codes, updated service history codes or amendments to owner details.

12.4 Hardware:

The Interface is provided with every rebreather with a serial lead connection as well as an USB/serial adaptor lead for those users that don't have a serial port on their PC. The Interface connector plugs into the same connector as the Temp-Stik and is located in the lid of the scrubber. Take care to keep the connector dry when connecting and disconnecting.



WARNING! The rebreather must not be dived unless either the Temp-Stik is connected or a suitable blanking plug is used on both halves of the connector.

12.5 File Formats

There are two file formats for data downloaded from the rebreather:

The “*.CCL” are the user data files and can be opened using the APD Log-Viewer software, supplied with the rebreather. These can be edited with the Log Viewer to add the diver’s own details about the dive – location, weather, gas quantities used, etc. The filename is in the format 04C123456_030519_134531 Serial No_dive date_time of dive.dat . In this example 04C123456 is the serial No. of the rebreather, the date is the 19th May 2003, and the time of the start of the dive is 13:45 and 31 seconds. By timing it to the second every dive file will have a different name. The file name is assigned automatically and should not be changed.

The *.CCX file is the Master download file containing the unit’s service history and may be requested by the factory from time to time.

New Code:

Program updates, language options, decompression option release codes and User registration screen updates may be downloaded over the internet and uploaded to the rebreather via the same interface, these have the file format “*.CCR”. There is data file checking (write and read back), continuously during the upload procedure to ensure the integrity of the data. Should a “corrupt data” notice occur, simply try again using the same file. If the problem persists obtain a new file and upload that one. As always, there is factory support available should it be required. The decompression option release code files have security codes, which are generated from the individual rebreather’s serial No. The file will not be usable on other rebreathers.

12.6 Step by Step Guide to Software and Hardware Installation

Step One: PC system requirements

Minimum PC requirements for using the APD LogViewer and APD Communicator:

- Processor - 486+
- RAM - 1MB
- Operating System - Windows ME, 2000, XP or Vista (expected to work on 98 and NT but not guaranteed). It will not work with Windows 3.1, 95, or any non-Windows Operating System.
- A USB or Serial Port

Step Two: Install Interface Bridge (if using USB) and APD Communicator:

The latest version of the APD Communicator may be downloaded from www.apdiving.com . (It will be downloaded with an unusual suffix such as *.z19 to ease the download process through firewalls. The suffix should be changed to *.exe so Windows recognises it as an executable program.)

NOTE: If updating a previous version uninstall the previous version before installing the new.

1. Connect Interface Bridge to a spare serial port on your PC or spare USB port. If using the Serial/USB adaptor you will need to install the driver from the floppy disk provided with the adaptor lead. If not prompted go to Control Panel and select install Hardware.
2. Run: A:\APDCommunicatorSetup.exe following the instructions on screen. If you download it from the web, run the program (after uninstalling any previous version) from wherever you saved it. During the setup it creates its own directory under c:\program files\.
3. Once installed run the APD Communicator, select Settings and choose the COM Port. If the COM Port No. is unknown this can be checked using the PC’s Device Manager in Control Panel. The available ports are shown on the Settings screen.



4. The Download Directory will automatically default to a directory called “APD Log Files” under “My Documents”. If you desire you can change the download directory by entering the directory name and path in the “download directory” box on the Settings page. This is the name of the directory into which you want to save the *.CCL dive data files that you download from the rebreather.
5. The Upload Directory will automatically default to “My Documents”. You can change the Upload Directory by entering the filename and path in the “upload directory” box. This is the name of the directory into which you will save upgrade files that you either download over the Internet or are emailed by the technical support team at APD. Tip: create a directory called “Rebreather Upgrades” under “My Documents”.
6. With the electronics switched off, connect the interface to the female scrubber monitor port in the scrubber lid. Switch on by pressing the left switch on the handset; PC Link will be displayed on the handset’s screen. Both HUDs should display steady Red.
7. If you have the correct COM port chosen (and the rebreather is showing PC Link) the large grey icon boxes on the start screen will transform into coloured rebreathers and PCs.
8. The first job is to set the date and time in the rebreather. Select Clock and then Synchronise if you are happy to have the rebreather on the same time and date as your PC. Tip: If you use Windows XP and are connected to the Internet double click the time in the bottom right hand corner and then select Internet time to bring your PC up to the correct date and time before synchronising with the rebreather.
9. Click on the top bar of the front screen and the details of your rebreather software will be displayed. This information can be compared to the latest software versions on the www.apdiving.com website to ensure you have the latest version of software for all three processors, display, C1 and C2.

The rebreather and APD Communicator are now setup for downloading dive data from the rebreather and for transferring any upgrade files to the rebreather.

Step Three: Install the APD LogViewer program:

The latest version of the APD LogViewer may be downloaded from www.apdiving.com . (It will be downloaded with a strange suffix such as *.zl9 to ease the download process through firewalls. The suffix should be changed to *.exe so Windows recognises it as an executable program.) **NOTE: If updating a previous version uninstall the previous version before installing the new.**

1. Run: A:\APDLogViewerSetup.exe and follow the on-screen instructions. If you download it from the web, run the program (after uninstalling any previous version) from wherever you saved it. During the setup it creates its own directory under c:\program files\.
2. If you have no dives yet on your rebreather either download a sample dive from the web or use the one on the floppy disk.

Step Four: Go diving.

You need to dive deeper than 1.2m (4ft) otherwise the rebreather will not enter underwater mode and start dive logging.

Step Five:

Once you have been diving, download the dives using the APD Communicator by connecting the Interface, switching on the handset (press the left switch once) so “PC Link” is shown on the handset. Start APD Communicator and select the large colourful download icon on the main screen, then click on download to transfer the data files (*.CCL) from the rebreather to the APD Log Files directory.

Step Six: Start the LogViewer

1. Once installed run the APD LogViewer, select File, Open and change the directory in the “Look In” box to the same directory name used in the APD Communicator to store downloaded rebreather log files: Tip: use C:\...\my documents\APD Log Files – browse to find the directory.
2. Double click on the relevant data file. A typical data file would have a similar filename to this: 04A123456_040523_160922.ccl, which shows the serial No. of the rebreather, followed by the date of the dive in the format yy,mm,dd (23rd May 2004 in this example), followed finally by the time of the dive in the format hrs,mins,secs. In this example the time of entering the water was at 16:09 and 22 secs.

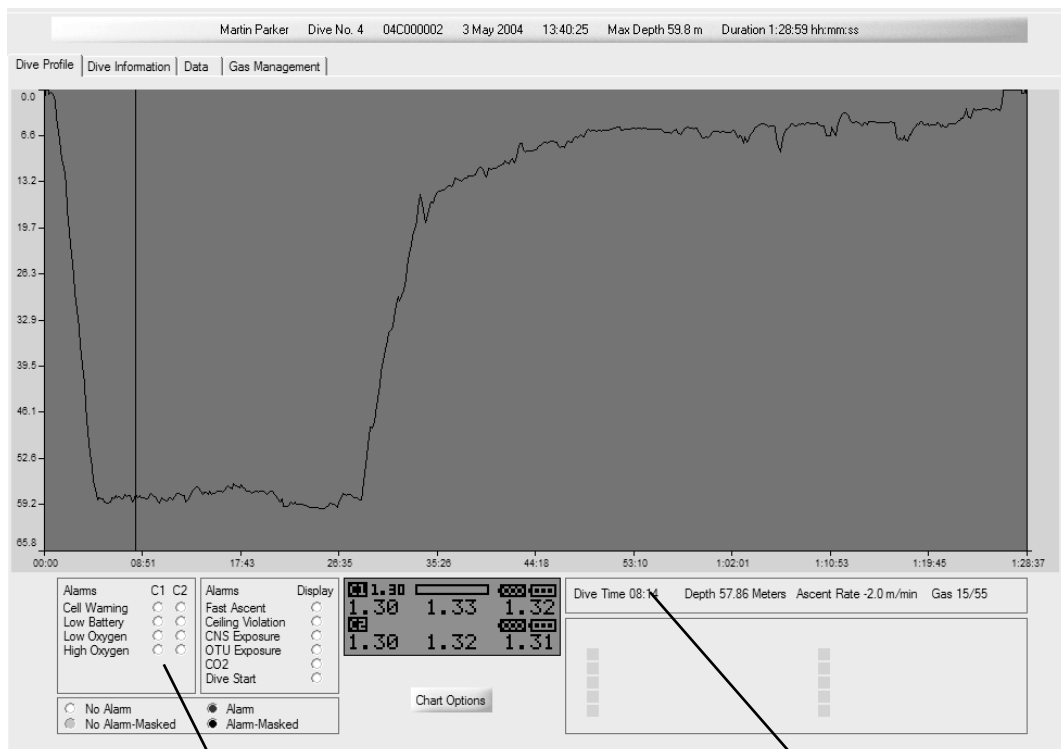

Warning buttons

Dive timer buttons

3. Move the cursor across the blue screen. The green ppO₂ display will show what the ppO₂ display was reading at all stages of the dive. The dive timer detail box shows the dive time where the cursor is, the depth, the ascent rate, or descent if negative, and the gas (diluent) the handset is set on.
4. If any warnings occur the buttons in the warning boxes light up as they occur during the dive. If the button is clear the warning didn't occur at that moment on the dive, if the button is red the warning was active, if the button is black the warning has been manually suppressed/masked. If the button is grey, the diver masked the warning but then subsequently the warning cleared itself.
5. Cursor Zoom: left click, hold, and move the cursor then release and it will zoom in. Right click will zoom out.
6. Sticky Cursor: double left click and then move the cursor. The vertical bar turns red and stays where it is. If you want to move the position of the cursor simply click once and the cursor will move. Double click again and the sticky cursor is removed.
7. Select Chart Options and the dive profile may be overlaid with ppO₂, Battery Voltages, Cylinder pressures (if we install pressure sensors on the cylinders in the future), Ambient Temperature, Gas Toxicity: CNS/ OTU, Decompression Ceiling according to chosen Gradient Factors or conservatism setting, and CO₂ –(if we install a CO₂ sensor on the unit in the future). At any time the dive profile may be printed by selecting File, Print, Profile.

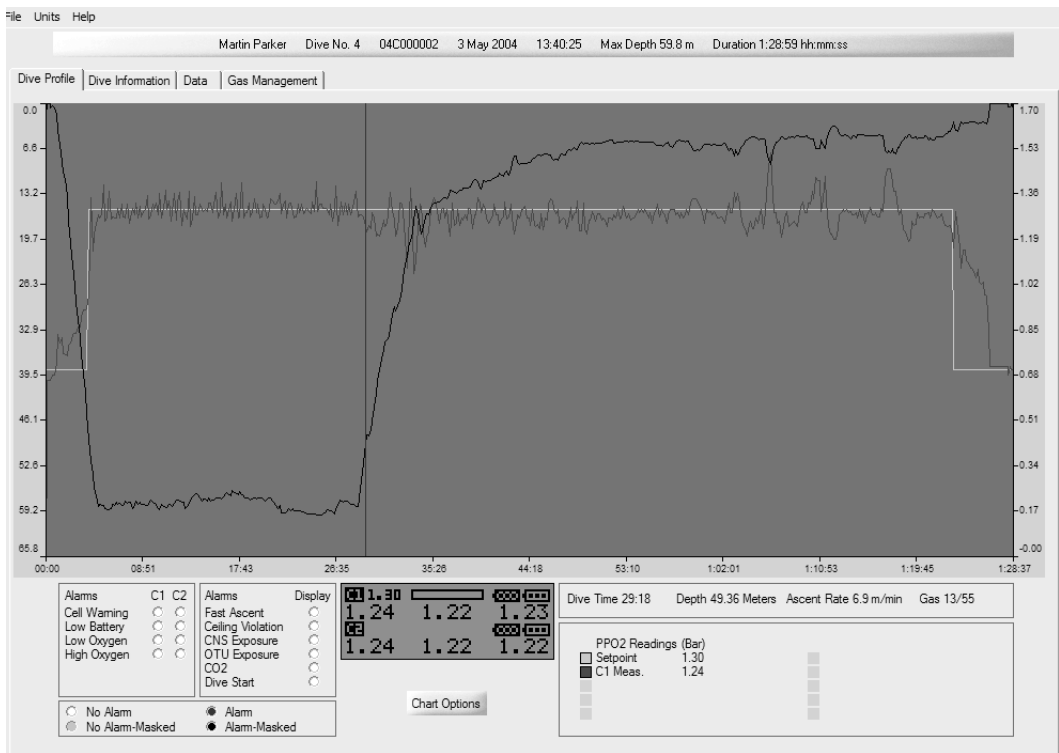

8. Selecting the information tab reveals the following screen:

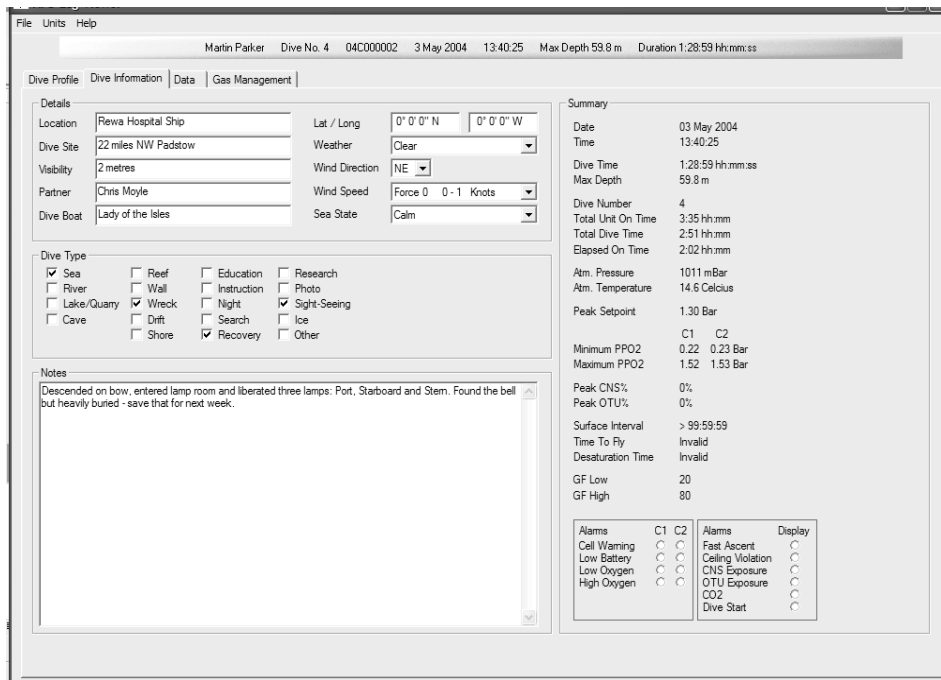

The right hand side, entered automatically from the rebreather, is reserved for the rebreather information such as the Date and Time of entering the water, the dive time (time from leaving 1.2m to reaching 0.9m), the max. Depth, the dive No., the total time the unit has been turned on, the total dive time (the total time underwater), the elapsed on time (since re-setting to zero), the Atmospheric Pressure and Temperature at start of dive, the peak setpoint, the minimum and maximum ppO₂s. Peak CNS and OTU % (not shown), the surface interval since the last dive in hours, mins and secs, with a maximum display of 99 hours, 59 mins and 59 secs. After that it displays a " >" (greater than sign). It also displays, time to fly and desaturation time after the dive (not shown), the gradient factors if the Trimix version is selected or Conservatism level on the Nitrox version (not shown). The box in the bottom right corner shows if any warnings occurred during this dive (Cell warning, low battery, low oxygen, high oxygen, fast ascent, ceiling violation, CNS Exposure, OTU exposure, CO₂ or Dive start.)

The left hand side may be amended to act as a record for that dive.

9. By selecting the Data tab the raw data may be copied to clipboard and subsequently pasted into a spreadsheet such as Excel.
10. On the Gas Management page the cylinder sizes and pressures in and out may be recorded and the gas quantities used will be calculated. If you change the Units to Imperial (feet and psi) you will need to enter the working pressure (the normal fill pressure) of the tank for the gas consumption calculations to be converted to Cubic feet.
11. Be sure to save the file once you have entered the dive data.

SECTION 13

13.0 MAINTENANCE

This must not be undertaken without prior training!



WARNING! Do not alter or modify the apparatus in any way without prior written approval from Ambient Pressure Diving Ltd. Any such action may affect the effectiveness of the apparatus and may affect the warranty.

13.1 CO₂ Absorbent Replacement

The CO₂ cartridge is easily refilled by the diver. The normal weight of Sofnolime required is 2.45 kg of 1-2.5mm (8-12 mesh) granule size. Use Sofnolime 797-Diving Grade, preferably “non-colour indicating”.

The procedure of replacing the Sofnolime for a cartridge with and without the ‘Clamseal spacer is as follows (unless specified otherwise)

- a) Remove the CO₂ scrubber cartridge from the casing. Lift and twist the 3 black fasteners and remove the lid complete with the hoses by pushing down with your thumbs on two of the black fasteners.
Original spacer and O-ring only: If equipped with an existing cartridge remove the spacer ring and O-ring and set aside
- b) Using the Moulded centre stem on top of the cartridge pull the cartridge from the canister.
(Do not pull on cable/lead)
- c) Empty the used Sofnolime into a suitable container for disposal.
- d) Ensure the filter is clean and dry before refilling. Fill the cartridge to about halfway. Whilst filling, tap the canister gently on four sides to aid settling. Continue to fill to within 6 mm of the top edge.
- e) Place clean/dry filter sheet next to the Sofnolime and replace the pressure spider. Screw retaining nut on hand tight only. Tap the sides of the cartridge to settle the Sofnolime and tighten the retaining nut until the pressure spider is flush with the top of the cartridge. Over-tightening will crush the Sofnolime.
- f) Before re-inserting the cartridge check to see if the bore of the canister where the O-ring will seal is clean and damage free. Inspect the large O-ring for damage and ensure it is lightly lubricated. This O-ring is extremely important as it prevents CO₂ bypassing the Sofnolime. Also ensure the O-ring is sitting evenly around the cartridge and not trapped beneath the clam seal spacer.
- g) Carefully re-insert the cartridge ensuring that you do not scratch any components. Ensure the whole assembly slides easily up and down, if it doesn't be sure to remove the cartridge, check the O ring is not trapped and lubricate it. Check around the inside of the clam seal spacer to ensure the O ring is not trapped but seated correctly, completely in contact with the scrubber wall.
Original spacer and O-ring only: If equipped with the existing cartridge carefully place the O-ring followed by spacer ring
- h) Replace the lid of the canister aligning the recess in the lid with the down pipe on the side of the canister. Fasten the three lid retainers by pulling them up and rotating 90° and ensure the faces of the lid and the scrubber body are butted against each other.



WARNING: The Large O-ring at the top of the cartridge prevents CO₂ in the expired gas from bypassing the Sofnolime. If the bore is scratched, the O-ring is damaged or not lubricated or not replaced after a service, CO₂ will be inhaled!

Further Precautions:



WARNING: Do not attempt to partially fill the cartridge. It must be filled completely otherwise the spring loaded packing system will not function which can result in absorbent material falling out of the cartridge and most importantly will result in insufficient spring pressure to compress the cartridge and O ring against the spacer. If this was to happen the large O ring would not seal on the bore and would allow CO₂ to bypass the CO₂ absorbent.



WARNING: Do not leave the cartridge open to the atmosphere and expect the Sofnolime to be effective enough for diving. Instead, seal it up by inserting it back into the canister, reconnecting all the hoses and breathing bags, and be sure to remember to close the mouthpiece!



WARNING: Under no circumstances should partially used absorbent be emptied from the scrubber then poured back in later. This will result in premature CO₂ breakthrough.



WARNING: Under no circumstances should some of the absorbent be removed and replaced with fresh material. If you are going to change the absorbent, change it all.



WARNING: Do not leave absorbent open to the atmosphere. The degree of contamination will be unknown and the absorbent may dry out. Sofnolime when new contains approx. 18% water which is essential in the CO₂ absorption chemistry.

CAUTION: Sofnolime is alkaline so appropriate safety measures should be implemented. Protective gloves, goggles, overalls and nuisance dust masks should be worn when handling Sofnolime granules irrespective of whether they are in a fresh or used state.

The granules or any entrained dust should not be allowed to come into prolonged contact with the skin and contact with the mucous membranes and the eyes must be totally avoided.

Residual or waste Sofnolime will contain some residual alkalinity but can normally be disposed of at a suitable landfill site.

Granules will bleach boat decks, so avoid spilling and be sure to clean up afterwards.

The Manufacturer's Safety Data Sheet is available on their website. The current one at time of publication is in Appendix 7.

Always inspect the cartridge prior to diving.

Removing the CO₂ Scrubber and Sofnolime Cartridge

Removing the Canister and Lid:

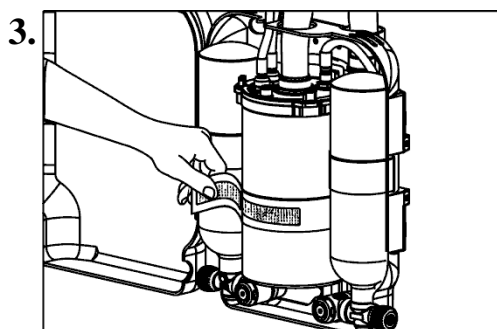
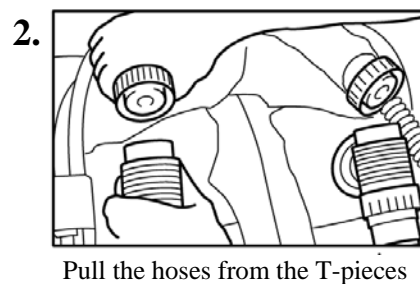
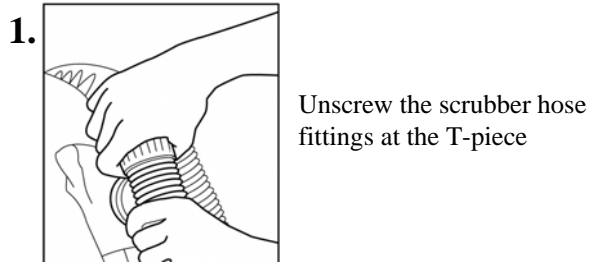

Pull apart the Velcro strap surrounding the canister releasing the Canister from the casing.

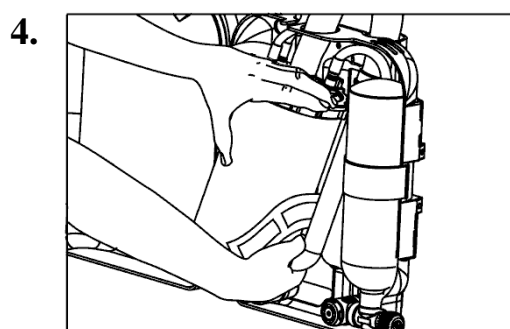

Remove scrubber hoses and electronic units from the casing.

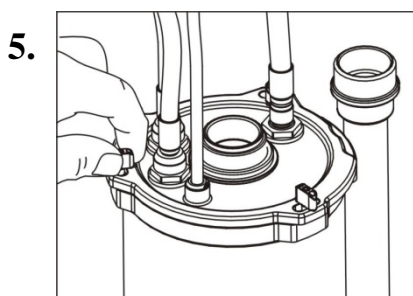

Lift each catch slightly and twist 90°

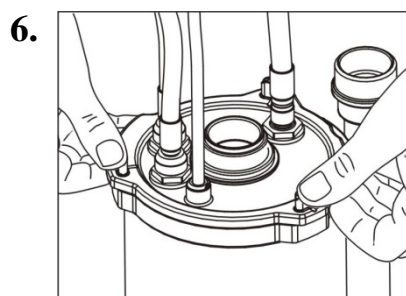

Remove the lid by pulling upwards

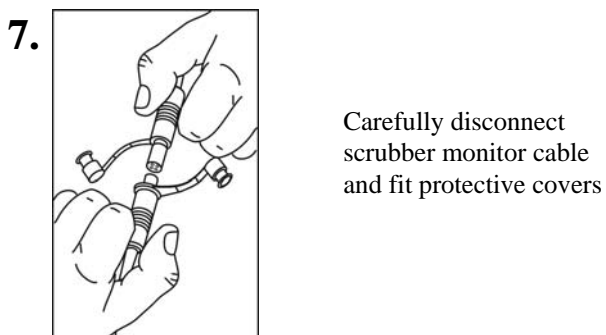

Removing the Cartridge:

Cartridge with Clamseal Spacer

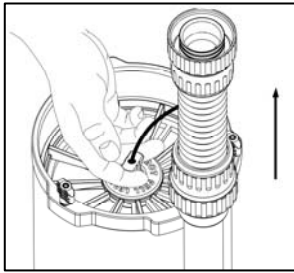

Stand the scrubber on a flat surface and remove the cartridge using the moulded centre stem



WARNING!
Do not pull the cable

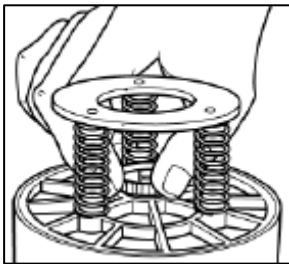

Turn the cartridge over and unscrew the retaining nut

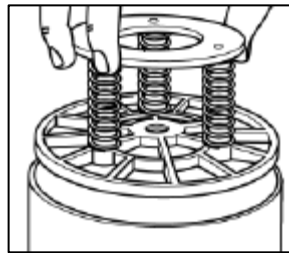

Remove the spring/
pressure plate
assembly

Cartridge with Loose Spacer

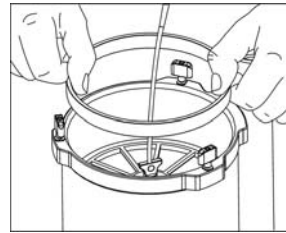

Remove spacer

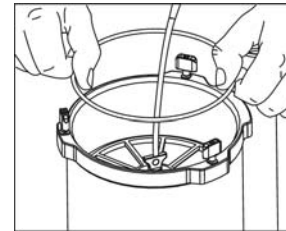

Remove large
O-ring



WARNING!
*Handle with care
and keep safe*

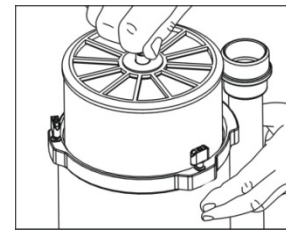

Remove the cartridge
using the moulded
centre stem.



WARNING!
*Do not pull the
cable*

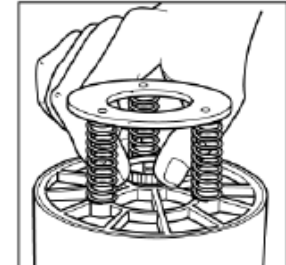

Turn the cartridge over
and unscrew the
retaining nut

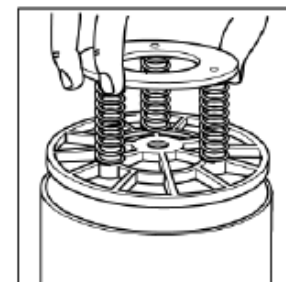

Remove the spring/
pressure plate
assembly

Refilling the Sofnolime Cartridge

1.



Ensure the filter scrim is clean and undamaged. Push in into the cartridge as far as it will go.

2.

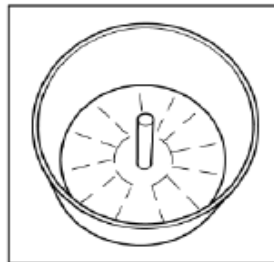

The filter scrim must be located properly in the bottom with no gaps around the edges or the centre column. Its purpose is to retain the Sofnolime granules and keep water out

3.

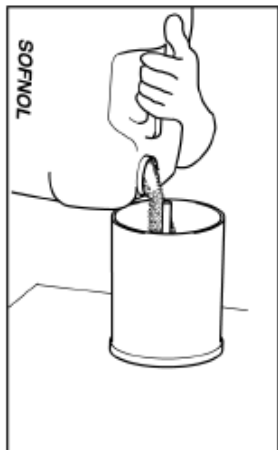

Store Sofnolime in the manufacturers sealed containers, following their storage instructions

4.



Fill to approximately half way and tap gently on the sides to level the granules

5.

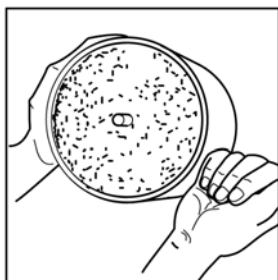

Fill to within 6mm of the top and tap gently on the sides to level the granules

6.

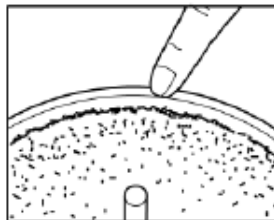

Ensure there is a 6mm gap at the top

7.



Ensure the scrim is clean and undamaged

8.

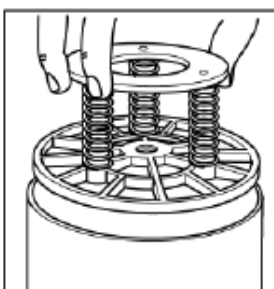

Fit the spring loaded pressure spider

9.

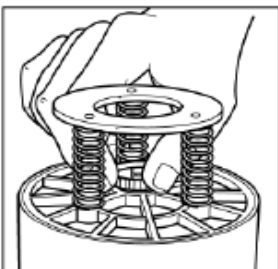

Fasten the retaining nut

10.

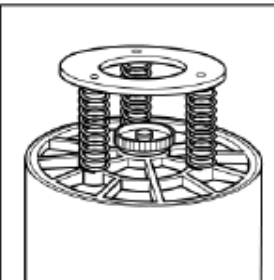

Do not over-tighten the retaining nut

Mistakes to avoid when filling the Sofnolime cartridge

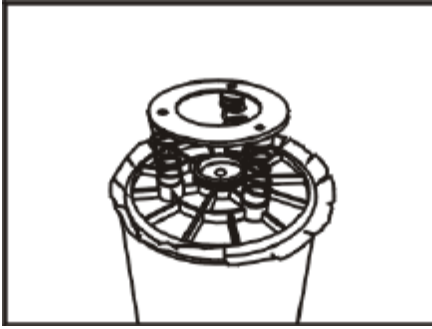

Do not overfill.
Over-filling combined with over-tightening makes the sides of the cartridge bulge and prevents the springs from pushing the cartridge against the O ring

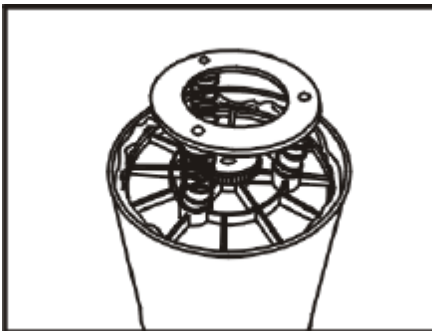

Do not under-fill; this allows CO₂ to by-pass the whole cartridge, as pressure is no longer applied to the O-ring

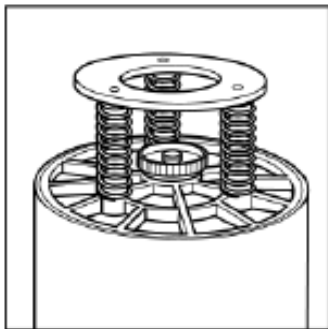

Do not over-tighten the retaining nut

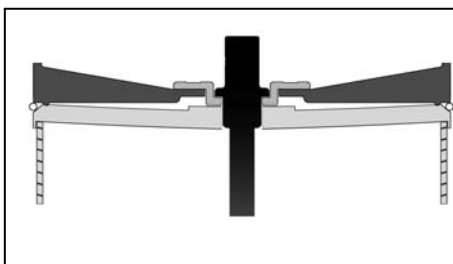

Over tightening of the retaining nut will pre-compress the O-ring making it difficult to insert your Canister. If this happens loosen off your retaining nut and ensure the 'Clamseal' spacer has movement.

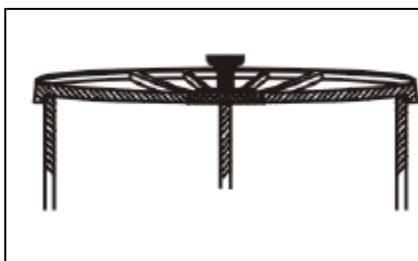

Avoid over-tightening the retaining nut. Over-tightening the retaining nut may distort the top. This may cause the canister to come adrift from its parallel sides. If this happens return the canister for repair

Re-fitting the Cartridge and Complete Scrubber Assembly

Cartridge with Clamseal Spacer

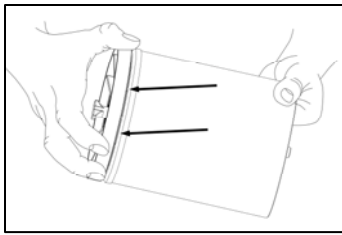

After inspecting the bore for damage or dirt - Ensure this O ring is undamaged, clean, lightly lubricated and properly located. Also check for any dirt or damage on clam seal spacer.

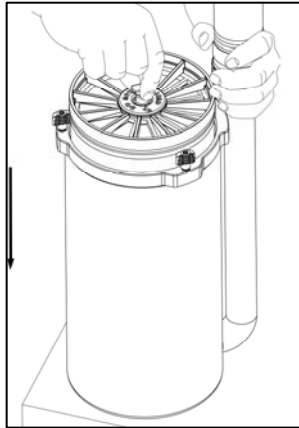

Stand the canister on a flat surface and slowly and carefully insert the cartridge into the canister. Allow gravity to insert the canister, taking care not to scratch any components. If the cartridge does not slide in under it's own weight, check the O ring is not trapped up the side. Under no circumstances should you push the cartridge into the canister.

Once in position check for free up/down spring loaded movement of the cartridge within the canister by pushing down on the cartridge.

Check around the inside of the clam seal spacer to ensure the O ring is not trapped between the clam seal spacer and the lid of the cartridge.

Cartridge without Clamseal Spacer

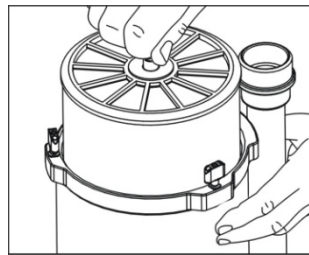

After inspecting the bore for damage or dirt - Insert the cartridge carefully taking care not to scratch any components

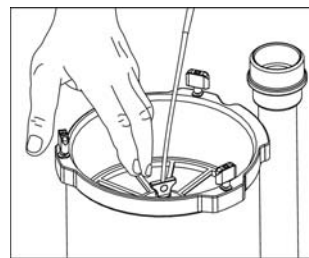

Push down and ensure the cartridge is free to move up and down and check for the spring loading effect of the pressure spider

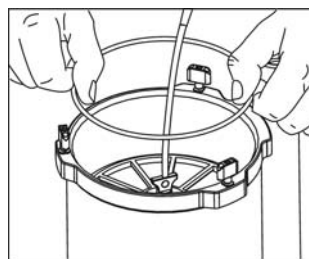

Ensure this O ring is undamaged, clean, lightly lubricated and properly located. Also check for any dirt or damage on the top of the cartridge and place the O ring on top.

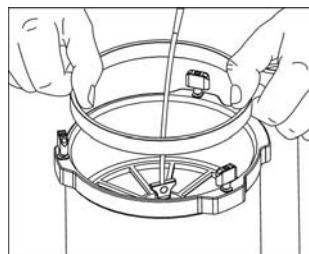

Ensure the spacer ring is clean and undamaged and place carefully onto the O ring. Again push down and ensure the cartridge is free to move up and down and check for the spring loading effect of the pressure spider. If the spacer ring is marked on one side, turn it over to ensure the good side sits on the O ring. Should both sides of the spacer be marked, replace the spacer with a new one before diving.

Continued...

1.

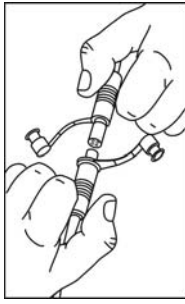

Connect the scrubber monitor cable.

2.

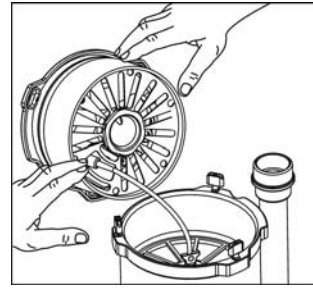

Ensure the bottom lip on the canister lid is undamaged, clean and properly located.

Tuck the excess cable and connector into the lid spacer.

3.

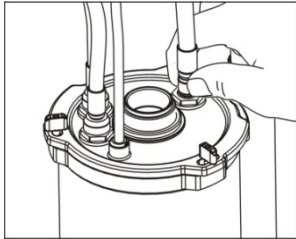

Fit the canister lid on carefully

4.

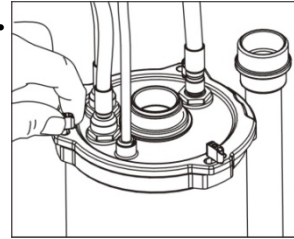

Lift and turn each catch to lock the lid in position

5.

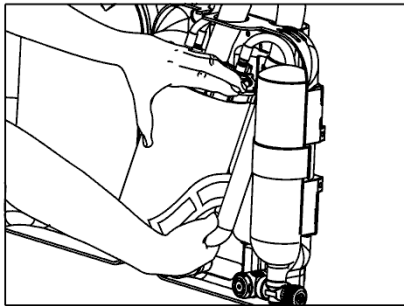

When re-inserting the scrubber assembly ensure the Velcro band passes between the scrubber wall and the down pipe

6.

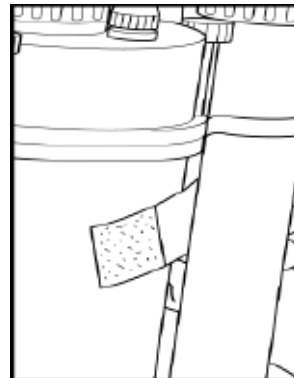

Re-fasten the hoses. Nip them up hand tight. Excessive force does not improve the sealing effect so DO NOT over-tighten.

7.

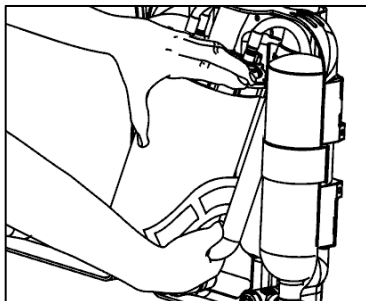

The scrubber locates on the back frame and is held in place by the Velcro band. The inlet pipe **MUST** sit underneath the cylinder against the back-frame.

8.

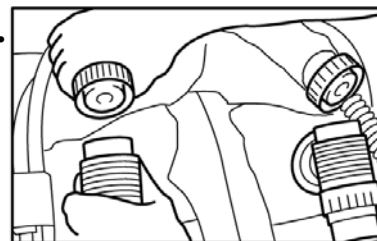

Re-fasten the hoses. Nip them up hand tight. Excessive force does not improve the sealing effect so DO NOT over-tighten.

13.2 Gas Cylinders

The two gas cylinders are each secured to the carrying frame by a single band in the centre of the cylinder. When securing the cylinders into the carrying frame - pass the band through just one of the slots in the buckle, tighten the band and fasten the Velcro.

Do not use cylinder mesh or other protective cover on the cylinders. The band and rubber anti-slip pads must be in contact with the painted cylinder surface to function properly.

The oxygen cylinder is located on the right hand side of the user and the diluent on the left. The diluent cylinder will be on the same side as the buoyancy compensator's inflator. Both cylinders are marked according to their contents.

From new, the oxygen cylinder and oxygen components, such as the first stage, hoses, contents gauge and inflator, are oxygen clean and compatible.



WARNING! It is recommended that the condition of the cylinder be assessed at 6 monthly intervals. In particular, if the oxygen cylinder is contaminated with salt water then it must be cleaned without delay otherwise corrosion will rapidly occur in an oxygen rich environment.

The diluent cylinder, first stage and components, however, are NOT oxygen clean as the diluent used is normally compressed air. If it is intended that this rebreather is to be used with a Trimix or Heliox diluent and the fill method is by partial pressure blending, then it will be necessary to oxygen clean both the cylinder and cylinder valve.

Contact Ambient Pressure Diving, as some of the valve components and the lubricant must be replaced.

13.3 First Stages

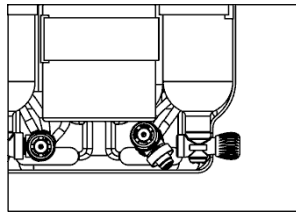
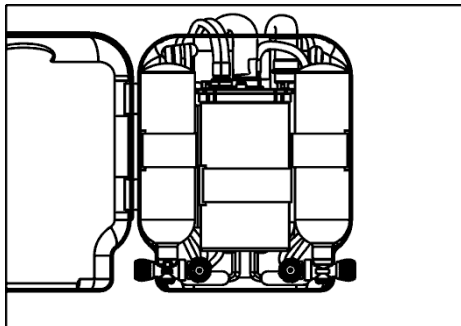

After closing the cylinder valve and purging the hoses, unscrew the DIN handwheel. If this is difficult, ensure all the pressure is released from the system. Keep this connection well lubricated using oxygen compatible grease. **DO NOT USE SILICONE GREASE OR OIL.**

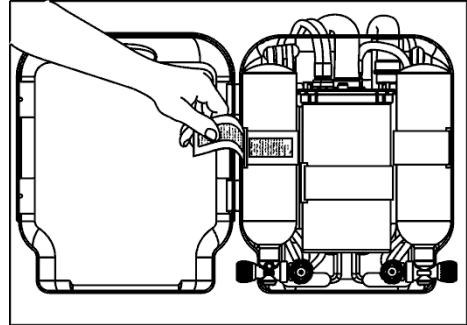

Un-do the webbing band

Both the oxygen and diluent cylinders use a first stage pressure reducer. Both are marked accordingly and must not become mixed up. i.e. do not use the oxygen 1st stage on the air cylinder and vice versa. The oxygen 1st stage has been specially prepared using oxygen compatible O-rings and lubricants - the diluent cylinder has not. It is only prepared for use with Normoxic gas (21% oxygen). The practice of relying on the diver inserting the correct valve into the correct cylinder is common in the technical diving communities on both sides of the Atlantic, the DIN thread being the preferred connection. The responsibility for connecting the 1st stages to the correct cylinders is the responsibility of the diver - YOU.

An alternative connection for the oxygen cylinder is available if you require it. Contact the factory for details.

Both are adjustable diaphragm types but the following set up pressures must be adhered to when servicing:

Oxygen 1st Stage

- Interstage Pressure: 7.5 bar. Under no circumstances must the Interstage pressure be increased above 8.0 bar! The Interstage pressure should be adjusted with only 50 bar in the cylinder.

Diluent 1st Stage

- Interstage Pressure: 9.2 to 9.5 bar. The Interstage pressure of the diluent cylinder may be altered to suit the open circuit 2nd stage fitted – maximum pressure – 13 bar.

13.4 LP Oxygen Hose

Connect the low-pressure (8 bar) oxygen hose to the solenoid valve in the top of the scrubber. Finger-tighten using the knurled ring. **DO NOT USE A WRENCH** - It is extremely common for divers to use far too much force. Over-tightening does not improve the seal; it simply risks damaging other components.

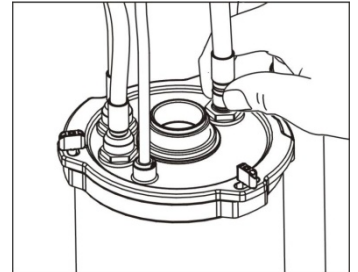

13.5 Post-Dive Maintenance

The breathing bags and mouthpiece should not be completely stripped down after every use. You are more likely to create problems for yourself.

13.5.1 Cleaning and Disinfecting the Unit

We advise users to disinfect their rebreather after each day of use. Only in this way can its cleanliness be ensured. However, disinfecting involves some disassembly and if not carried out with care, leaks may be introduced into the system during reassembly. It is important that leaks are rectified if the reliability and integrity of the system is to be restored. If the rebreather is shared with another diver the system should be thoroughly disinfected before use.

After each dive the mouthpiece should be rinsed in fresh water, taking care not to allow large quantities of water to enter the loop. Providing the rebreather is standing upright, all the water will enter the exhale counterlung and this is easily drained. Take care not to allow too much to enter while the scrubber hoses are still connected.

At the end of each day's diving remove the hose and the mouthpiece as an assembly, rinse in a disinfectant solution such as BUDDY Clean and rinse thoroughly in fresh water.



WARNING! Do not use solutions of Milton or other baby bottle sterilising solutions. These discolour and rot the inner and outer bags.

After every 6 hours total diving; disinfect the mouthpiece, hoses, counterlungs and inside the canister. Inspect the counterlungs for foreign matter; the outer bag of each counterlung has a zip to aid inspection of the inner. It is necessary to allow the components to soak for 10 mins in a 100:1 (Water:Buddy Clean) diluted solution. Please note: Buddy Clean is supplied undiluted so requires dilution for use. Do not leave components soaking in cleaning solution for more than 30 minutes. Rinse thoroughly afterwards with fresh water, preferably sterilized water (pre-boiled and cooled) and then allow to dry.

13.5.2 BUDDY Clean Disinfectant

BUDDY Clean Disinfectant has been specially formulated for its ability to destroy a wide variety of bacteria, viruses and fungi including Legionella, Weil's disease, Tuberculosis, HIV and also for its very low hazard risk. Buddy Clean is supplied undiluted. The product should be diluted 100:1 (Water:Buddy Clean) prior to use. See Appendix 5. BUDDY Clean is not FDA approved for use in America; Silent Diving Systems LLC (www.silentdiving.com) should be consulted for approved disinfectant in the USA.

13.5.3 Lubrication

It is essential when lubricating seals or O-rings on the rebreather and oxygen valves, that oxygen compatible grease is used. Recommended greases include Fomblin RT15, Halocarbon 25-5S grease and Oxygenex FF250.

13.5.4 Washing and Disinfecting the Breathing Circuit

1.

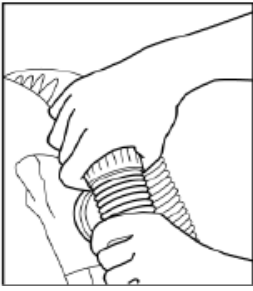

Unscrew the rear most hoses from both T-pieces

2.

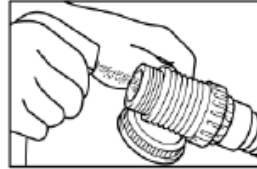

Spray or pour BUDDY Clean disinfectant into the T-piece

3.

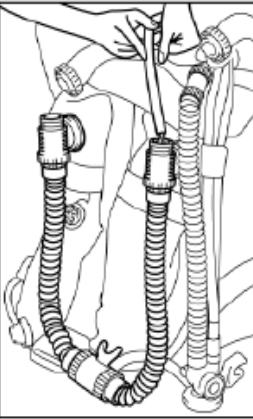

With the mouthpiece closed, use a clean hose to fill both counterlungs with warm, fresh water

4.

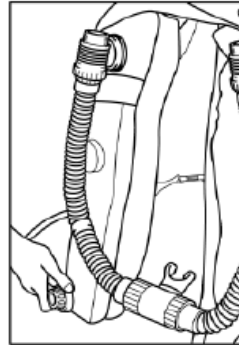

Unscrew the inflators, taking care not to lose the O-rings

5.

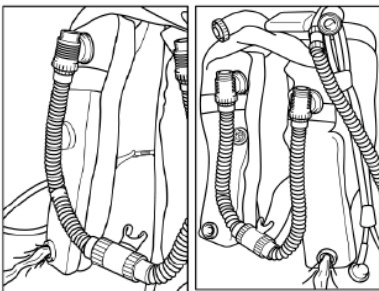

Repeat the process, thoroughly flushing the counterlungs with fresh water

6.



Remove the hoses and spray or pour disinfectant into the inhalation hose

7.

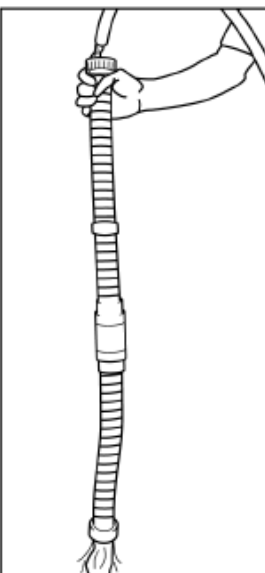

Use a clean hose to flush through with warm, fresh water

8.

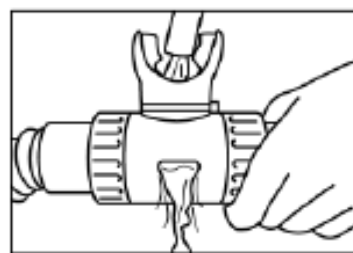

Spray the mouthpiece with disinfectant and thoroughly flush through. Do this with the mouthpiece open and closed to wash the water drain

Always check the non-return valves for proper operation after washing.

13.5.5 Oxygen Sensors

If, after the dive, water is suspected to have entered the scrubber then the unit must NOT be stored horizontally. To do so will result in the oxygen cells and the battery compartment becoming soaked. Should this occur the cell face should be washed in warm fresh water, the batteries removed, any residue removed and the lid air-dried.

13.5.6 Exchanging Oxygen Sensors

Oxygen sensors are a consumable item and should be replaced regularly. The life of a sensor varies with the temperature and the ppO_2 it is exposed to. The higher the temperature or the higher the ppO_2 the oxygen cell is stored at, the shorter the life of the cell. Simply leaving the oxygen cells in the lid at a temperature between 5°C and 25°C in AIR is sufficient to aid a reasonably long life.

Important:

- When finished with the rebreather for the day, ensure the sensors are in air, not at 0.7 bar (the ppO_2 in the loop at the end of the dive).
- Typically in the rebreather application, oxygen cells must be replaced when they are between 12 and 18 months old.
- Each oxygen cell has a simple date code e.g.:

APD10 F6 = June 2006
APD12 102010 = October 2010

- When changing cells, some divers change one cell every 6 months, some change all three at 12 or 18 months, both methods work.
- Do NOT expose to temperatures higher than 50°C.

Please Note:

- When Ambient Pressure Diving service a rebreather lid, it will not be released from the factory without three in date, correct type, oxygen cells fitted.

It is extremely dangerous to use oxygen cells older than 18 months:

An oxygen cell generates current. The higher the ppO_2 the higher the current generated and the higher the mVolt output (- the potential difference across a resistor in the circuit).

All oxygen cells are current limited. When an oxygen cell is new, current limiting occurs at around 4 to 5 bar. In use the lead anode is consumed and the level at which current limiting occurs drops lower and lower. Once a cell is current limited below 1.6 then it will start to affect the function of the rebreather, below the setpoint it will affect the oxygen addition.



WARNING! – Avoid current limited cells – never use an oxygen cell older than 18 months

To check for a current limited cell, simply add a little oxygen manually and see if the display goes above setpoint. If it does the cell is okay, for now.



WARNING! – To use old oxygen cells is “Russian Roulette”. The cell will be current limited at dangerous levels at some time in the future.

See www.apdiving.com/videos

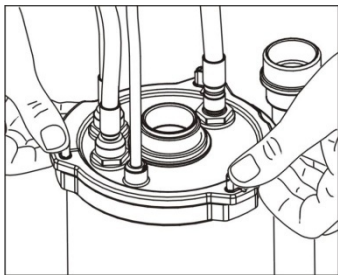

To replace the oxygen cells it is necessary to remove the scrubber from the rebreather.

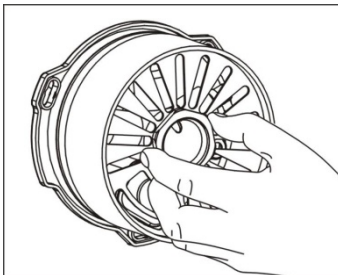

Unscrew the securing ring for the mixing chamber cover and pull the cover from the centre stem.

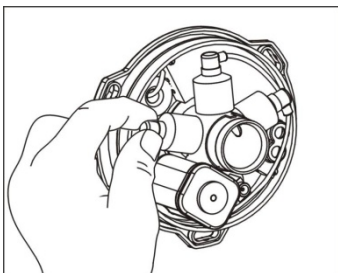

Remove the blue connector covers and pull the cell connector from the cell (straight pull).

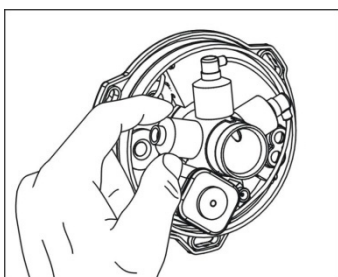

Remove the sensor by unscrewing it (anti-clockwise).

Sometimes the oxygen cells are supplied with an O-ring on the M16 thread – this is not required and could be removed.



WARNING! Only APD10 or APD12 oxygen cells supplied by Ambient Pressure Diving should be used. Some oxygen cell manufacturers believe they manufacture a replacement cell for those used in the Inspiration, Evolution and Evolution+, however they do not have a complete understanding of the requirements, whether it be environmental conditions, methods of use or the static and dynamic requirements of the cell in use as well as the compatibility requirements with the VISION electronics and it is only with extra quality assurance performed at Ambient Pressure can the oxygen cells be determined as “fit for purpose”. Several accidents have occurred due to the diver fitting non-Ambient Pressure Diving supplied oxygen cells.



WARNING! DO NOT USE a mix of APD10 and APD12 oxygen sensors together. You must use 3 of APD10 or 3 of APD12, not a mixture of the two types.

Re-assembly:

1. Carefully screw the replacement oxygen cell into the holder, taking care not to cross the thread.
2. If the diver requires to measure the output voltage of a cell, this **MUST ONLY** be done by using a proper connector and measuring the voltage across the inner and outer conductors of the co-axial cable. Every rebreather is supplied with a spare connector.



WARNING! The sharp probes of a voltmeter **MUST NOT** be pushed into the centre of the oxygen cell's connector.

DO NOT do this!
You will damage
the connector.

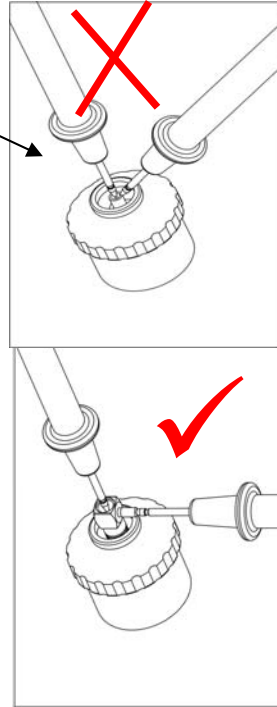

3. If you need to measure the output voltage of the oxygen cell, attach a spare connector to the cell and place your DVM (Digital volt meter) probes on the connector. The central pin is +ve and the exterior of the connector is -ve.

4. Push the blue cover gently back over the connector and into the oxygen cell taking care not to put strain on the wires.
5. Push the mixing chamber cover into place, ensuring there are no wires trapped underneath it and the slot in the inside bore aligns with the keyway on the sensor holder.

13.6 Storage

Rebreathers should be stored upright or lying on its counterlungs. If you lay the rebreather on its back at the end of the dive then you risk water running onto the face of the no. 2 oxygen cell. This may result in a cell failure when you next switch the unit on and the oxygen controller will not enter dive mode - preventing you entering the water. Cell 2 should then be removed and allowed to dry naturally before use. Repeated or excessive soaking will reduce the life of the cell.

The oxygen cells can be stored down to -20°C without consequence, unless freezing and thawing cycles are repeated, in which case the electrolyte seals may be damaged with the possibility of leakage of the electrolyte. Intermittent exposure to temperatures of 45°C is acceptable, though continuous exposure to high temperatures will shorten cell life.

After cleaning, store the apparatus upright, out of direct sunlight, with the BC and counterlungs partially inflated, in a cool, (5-15°C), dry and dust free place. Avoid exposure to direct ultra-violet radiation and radiant heat.

13.7 Precautions when using High Pressure Oxygen



Warning: Open cylinder valves slowly.

Use only oxygen clean components and oxygen compatible materials.

Ensure there is no oil or grease contamination.

See Section 13.5.3 for suitable lubricants.

13.8 Service Intervals

Maintenance is an ongoing task with all rebreathers and users must check for proper operation before every dive. Additionally some components must be serviced at periodic intervals:

Diluent Cylinders:

As supplied from the factory these are prepared ready for normal quality diving air and as such are NOT specially oxygen cleaned. The same applies to the cylinder valve. The inspection and hydrostatic testing regulations for this cylinder will vary from Country to Country. In the UK, the current requirements are for internal inspections every 2½ years with a hydrostatic test every 5 years.

Oxygen Cylinders:

Supplied from the factory, these cylinders are oxygen clean. The legal requirement in the UK is for an internal inspection every 2½ years with hydrostatic testing every 5 years. Oxygen cylinders must be serviced and oxygen cleaned every year.

1st stages:

The 1st stages should be dive shop serviced on an annual basis.

Auto Air:

The Auto Air should be dive shop serviced annually.

Oxygen Cells:

The life of the oxygen cells will vary from cell to cell and user to user. Between dives the loop should be flushed with air. Leaving the cells in a high oxygen % shortens the life of the cells dramatically. The cells should be replaced every 12-18 months. They should be replaced immediately if signs of deterioration are present, regardless of age. Under no circumstances should you use the oxygen cells beyond 18 months from date of manufacture. Oxygen cells constantly deteriorate and have a finite life, even in the sealed packaging. If you hold a spare oxygen cell this should be discarded 18 months from the date of manufacture even if unused. Oxygen cells would be depleted in a matter of weeks if stored in an oxygen rich environment.

SECTION 14

14.0 EMERGENCY PROCEDURES

14.1 Bail-Out (Emergency Breathing)

Never dive without sufficient open circuit bail out

During a dive, very little diluent gas should be used. Typically only about 30 to 40 bar will be consumed from the 3-litre cylinder. The diluent cylinder provides gas for counterlung volume during the descent, for lung volume adjustments throughout the dive, for BC inflation and for dry suit inflation. If a Heliox or Trimix diluent is used it is recommended that a separate cylinder is carried for suit inflation. Because so little diluent is used, the diluent cylinder may provide sufficient gas for bailout. To take advantage of this an Auto Air is fitted to the BC. The Auto Air is also an overpressure relief valve should the First stage HP seat leak. If the Auto Air is removed it must be replaced with a suitable open circuit breathing system and suitable overpressure valve. For emergency breathing at 6 m and shallower, an oxygen clean 2nd stage can be used to breathe from the 2 litre oxygen cylinder. However, an isolator should be fitted in the line so that the oxygen supply to this 2nd stage is normally switched off to prevent accidental gas leakage from this 2nd stage and also to help prevent your diving partner from accidentally using this mouthpiece at depths greater than 6 m.

For extreme air dives and mixed gas dives the volume and type of bail out gases must be reassessed. For instance, you may decide to carry a 5 litre cylinder containing Bottom mix or 40% Nitrox or it may be best to carry two 7 litre cylinders hip or back mounted, one with Bottom mix and one with 80% or, depending on the dive scenario, it may be better to place bailout gas on the shot line. The bailout is just as much a limiting factor to your dive planning as the gas mix selected. Ensure you have sufficient volume of breathable, open circuit gas available at all stages of the dive.

14.2 Emergency Procedures

What do you do in the event of a Low oxygen warning?

What do you do in the event of a High oxygen warning?

What do you do in the event of a battery warning?

What do you do in the event of a battery failure?

What do you do in the event of a flooded loop?

What do you do in the event of a cell warning/cell error?

What do you do in the event of a CNS/OTU or CO₂ scrubber warning?

If in Doubt –

Flush with diluent
and consider
switching to open
circuit bailout.

– Ascend and abort. In the case of CO₂, reverting to open circuit bail out is strongly recommended.

14.3 Diluent Flush

This very simple procedure is the cure, albeit temporary in some cases, for most of the above problems. If the O₂ level is too low then flushing with diluent will raise the ppO₂ to a breathable level. If the ppO₂ level is too high, flushing with diluent will dilute the oxygen. If there is water on the cell face the diluent flush will aid evaporation. To perform a diluent flush press the diluent inflator, for approximately 10-15 seconds, whilst holding open the exhaust valve.

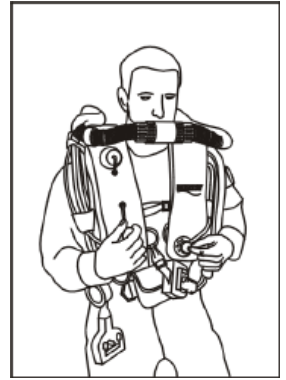

14.4 Emergency Rescue of an Unconscious Rebreather Diver

DO NOT remove the mouthpiece. Flushing the system with diluent may assist in the recovery of consciousness. A skilled and experienced rebreather user should be able to assess a buddy's system to identify a problem and affect a cure e.g. by opening the O₂ cylinder valve. If no probable cause can be identified then an assisted ascent may be carried out, regularly flushing the buddy's system to ensure a respirable mix is present in the loop.

14.5 Flooded Loop

A rebreather is very tolerant of water entry. The action to take largely depends on the circumstances leading up to this problem and how much water has entered.

If you have just dropped the mouthpiece without closing it and then re-inserted it, you will allow water into the exhale counterlung. Providing you stay reasonably upright you should be able to continue the dive, leaving the water in there. If you continue to do head down descents or somersaults, then water in the counterlung will find its way past the water trap and go into the bottom of the scrubber. This is noticeable by a more distant gurgling noise, which becomes worse when you roll onto your right side. Depending on the quantity of water, which has entered, this is not too serious a problem. You should, though, empty the water out at the end of the dive, dry the scrubber and change the Sofnolime.

There is a water barrier at the bottom of the Sofnolime cartridge, but eventually water will permeate around the edge of this and be soaked up by the Sofnolime granules. Because of the water traps at the top of the scrubber and on the top of the inhale counterlung, there is virtually no chance of getting a "caustic cocktail". However, if you do soak the Sofnolime excessively a faint chalky flavour may be noticed in the inspired gas. If this flavour becomes evident, in conjunction with the gurgling when you are on your right side, with an increase in breathing resistance, then the dive should be aborted, the system dried and Sofnolime changed.

Excessive amounts of water can be vented by rotating, so the overpressure valve is downwards, and pressurising the loop so the excess water is forced out. This requires practice and usually allows water into the bottom of the scrubber. Pressurising the loop causes excess buoyancy and so the diver must fin downwards or hold onto something substantial.

If you receive water down the inhale hose, it is most likely to be due to residual water in the counterlung remaining there after washing. Rotating into a head up position should enable normal breathing to commence.

If in doubt - bail out!

14.6 Manual Control of ppO₂

The ppO₂ can be held within the life support range by adding either O₂ or diluent. The gas may be supplied by on-board or off-board cylinders connected to the manual inflators on the counterlungs.

14.6.1 Manual addition of O₂ and O₂ flush method

Providing the ppO₂ displays are functioning and are monitored the ppO₂ can be maintained easily, by manually adding O₂ in short bursts.

With practice it is possible to maintain a constant ppO₂ without looking at the displays, but this involves timing the interval between oxygen injects or counting the number of breaths. However, this technique requires considerable practise and is only valid when the depth stays constant. This technique is deemed too dangerous.

To do a fast oxygen flush (at 6m or shallower), press the oxygen inflator for several seconds and purge gas from around the mouthpiece at the same time. Take a few breaths, then repeat flush. This is a very quick method and is easily done without affecting buoyancy.

14.6.2 Manual addition of diluent

Providing the ppO₂ displays are functioning and are monitored the ppO₂ can be maintained easily, by manually adding diluent in short bursts. Because you are adding inert gas to the loop, as well as oxygen, gas should be vented from the loop to maintain neutral buoyancy.

Maintaining a life sustaining ppO₂ is easy when adding diluent, even without a ppO₂ display. It needs practise, while watching the ppO₂ display, to make it efficient but it is a simple procedure. Practise, whilst monitoring the ppO₂ display, in a shallow swimming pool using an air diluent, start by exhaling through your nose every third breath and then adding air to allow you to breathe from the counterlungs. Some divers may find, by practising while watching their ppO₂ displays that they can exhale less often but please bear in mind the following warning:



WARNING! It is important to find the number of breaths between exhales when in the shallows and when working moderately hard and then using this at all depths. Do not experiment at depth and then apply your technique in the shallows. If you are using the rebreather in this semi-closed fashion as a bailout, it is important that the oxygen content of the diluent will sustain life in this semi-closed manner all the way to the surface. Beware of trying to use a diluent with only 15% or less O₂ content.

14.6.3 Using the Inspiration, Evolution or Evolution+ as a pure oxygen rebreather

It is easy to maintain a high oxygen content manually by monitoring the ppO₂ displays but if the display is switched off or not functioning then at depths of 6m and shallower it is possible to use the Inspiration, Evolution or Evolution+ as a pure oxygen rebreather. The technique is to flush out all the Nitrogen so there is only pure oxygen in the breathing loop, which includes the diver's lungs, and then add oxygen manually as the counterlung volume diminishes.



WARNING! This technique is potentially very dangerous and must not be attempted without proper training and practise whilst monitoring the ppO₂ displays. Complete oxygen flushing of the loop must be done thoroughly. If Nitrogen is present in the loop then there is a great risk of the diver going unconscious through hypoxia. Most Navies have accidents every year because the diver doesn't do an adequate oxygen flush when using a pure oxygen rebreather. Particular attention must be paid to the oxygen flush technique.

When 5 m or shallower select a low setpoint (0.7 bar), exhale through nose until counterlung volume diminishes - preventing the next inhale, add oxygen to counterlungs to allow next inhale. Breathe for a few breaths, and then repeat the process again three times. After that add oxygen when the counterlung volume diminishes enough to make breathing slightly difficult. Then add just enough oxygen to allow breathing. While you do this monitor the ppO₂ displays. After practise you should be able to maintain a pretty constant ppO₂.

SECTION 15

15.0 BRIEFING OPEN CIRCUIT DIVE PARTNERS

15.1 The Rebreather Diver – What to Expect, What to Do (Author: Stephen Bird)

BASICS

Closed Circuit (CC) Rebreather diving has a number of differences from Open Circuit (OC), but also a number of similarities.

ON THE SURFACE - In any problem scenario once back on the surface the CC diver should be treated exactly the same as an OC diver. This includes all DCS occurrences, respiratory problems and any other diving related ailments. Use of CC does not preclude the use of hyperbaric treatment.

UNDER THE WATER – The CC diver will do things slightly differently to the OC diver. Things you will notice, that are quite normal are:

- Buoyancy – The CC diver will swim around objects rather than over them
- Computer Checks – The CC diver will check the computers at 30-second intervals, this is essential in monitoring the well being of the equipment.
- Bubbles – There are usually none. Exceptions are mask clearing, upward buoyancy adjustments and always on ascents.
- Busy – On descent and ascent the CC diver will look busy; these are times of high task loading, once at working depth only the computer checks may be evident.

PRE-DIVE CHECKS – For the CC diver the usual buddy checks for buoyancy, air and releases is the same as OC, except that one source of gas (the closed circuit one) is checked as part of a unique CC check routine. This routine involves a complete, part computer guided, systems check the final part of which is a 3-minute breath test.

DIVE MARSHALL LOG – Again essentially the same as an OC diver, but gas consumption will be about 1 litre / minute from the Oxygen cylinder and negligible from the Diluent cylinder which is used mainly for buoyancy and OC back up (bailout). So the extra information to be recorded is O₂ contents, diluent contents, scrubber duration and PO₂ setpoint.

THINGS AN OC BUDDY SHOULD KNOW – How to open and close the CC mouthpiece, the operation of the diluent and O₂ manual inject valves, (but normally leave the latter well alone), and recognise the terms and symptoms of Hypoxia, Hyperoxia and Hypercapnia. This is within the skill-set of BSAC Sport Diver and above, but would possibly not be appropriate for anything less than a PADI Rescue Diver.

15.2 Classic Problems, Causes and Resolutions

The following table lists classic problems, the probable cause, the CC divers resolution and if required the buddy divers assisting action. It should be noted that a capable CC diver could resolve nearly all problems without switching to OC bailout, but that option always exists. For a rescuing buddy nearly all problems can be resolved with a diluent flush, but again the option to assist with OC bailout using on-board gas or his own OC octopus exists. The general rule is:

IF IN DOUBT, BAIL OUT.

PROBLEM	CAUSES	CC DIVER RESOLUTION	OC BUDDY RESOLUTION
Low Oxygen	Solenoid Blocked	Use O ₂ manual inject	Diluent flush or offer bailout / octopus, then diluent inject every third breath, then rescue to the surface.
	O ₂ cylinder valve switched off	Switch back on	Diluent flush or offer bailout/ octopus, check O ₂ cylinder valve is on, then rescue to the surface.
	O ₂ cylinder empty or no access to O ₂ at all	Use diluent flush, then go to diluent based semi closed mode	Diluent flush or offer bailout / octopus, then diluent inject every third breath, then rescue to surface.
	Fast ascent	Add O ₂ manually or diluent flush, slow the ascent.	Diluent flush, slow the ascent, offer bailout / octopus, then diluent inject every third breath, then rescue to surface.
High Oxygen	Solenoid jammed open	Diluent flush and switch O ₂ cylinder valve off, use valve to control injection of O ₂	Diluent flush and switch O ₂ cylinder valve off, offer bailout / octopus, then diluent inject every third breath, then rescue to surface.
	Accidental O ₂ manual injection	Diluent flush	Diluent flush, offer bailout / octopus, then rescue to the surface.
	Fast descent	Diluent flush and slow the descent	Diluent flush, offer bailout / octopus, then rescue to surface.
Full Electronics failure	Water ingress, batteries flat, broken something etc	Use diluent flush, then go to diluent based semi closed mode	Diluent flush or offer bailout / octopus, then diluent inject every third breath, then rescue to the surface.
Scrubber flood and caustic cocktail	Leakage of water into scrubber housing	Switch to OC bailout	Offer bailout / octopus, then rescue to surface.

SECTION 16

16.0 WARRANTY

The Inspiration, Evolution or Evolution+ rebreathers are warranted for the first owner for 12 months from date of purchase.

Conditions:

All warranty work must be authorised by Ambient Pressure Diving Ltd. Before returning the apparatus for any reason, please telephone the factory for advice. If it is deemed a factory repair is required the apparatus should be returned, postage and insurance paid, with a copy of the purchase receipt, directly to the factory, NOT TO THE DIVE SHOP.

1. Misuse, neglect or alteration renders all warranties null and void.
2. This warranty is not transferable.

Your statutory rights are unaffected.

Exclusions:

1. The batteries are not covered by the warranty.
2. The oxygen sensors are not covered by the warranty, they will need to be replaced every 12-18 months or sooner depending on the ppO₂ they are stored in.
3. The counterlung outer bag colours, even the black, will fade in time - especially if subjected to strong sunlight
4. The counterlung's inner bags are not covered against punctures.
5. If a strong sterilising fluid is used then the inner bags may deteriorate.

Applicable Law:

All products are sold only on the understanding that only English Law applies in any and all legal claims against the manufacturer, regardless of where the equipment is purchased or where used. Should a claim be made the venue for this will be Truro, England.

USA exception: All products are sold into the USA and to US Citizens and domiciles only on the understanding that only North Carolina Law applies in any and all legal claims against the manufacturer, regardless of where the equipment is purchased or where used. Should a claim be made the venue for this claim and subsequent action will be Raleigh, North Carolina.

Warning: It is dangerous for untrained and uncertified persons to use the equipment covered by this warranty. Therefore, use of this equipment by an untrained person renders any and all warranties null and void.

SECTION 17

17.0 IMPORTANT CAUTIONARY NOTES

Training alone is not sufficient to ensure your safety. Correct maintenance and diligent use of the equipment is essential. If sufficient forethought has not been given to equipment configuration, risk analysis, dive and emergency planning you could with one simple operation feed yourself with gas which will not support life.

DO: Know your ppO₂ at all times!

DO: Read the instruction manual fully before using the rebreather.

DO: Carry out the pre-dive checks (APPENDIX 10) prior to each dive.

DO: Use diving quality gasses.

DO: Post-dive maintenance, particularly cleaning and disinfecting the breathing loop.

DO: Have your rebreather serviced annually by a competent person.

DO: Insure all your dive equipment.

DO: Keep a record of the usage of the apparatus, particularly the Sofnolime, batteries and oxygen cells.

DO: Ensure that only original parts are used in the repair of the rebreather.

DO: Practice in a pool to increase familiarity with the operation and adjustments of the apparatus.

DO: Handle the Sofnolime safely and store it in a dry, airtight container.

DO: Only use the correct batteries and dispose of them immediately they are finished.

DO: Take spare oxygen cells and batteries when travelling.

DO: Connect blue to blue when reconnecting breathing hoses.

DO NOT: breathe from the loop without switching on electronics and checking ppO₂

DO NOT: ignore warnings

DO NOT: ascend too rapidly.

DO NOT: descend too rapidly. The ppO₂ may increase to dangerous levels.

DO NOT: mix up the diluent and oxygen fittings.

DO NOT: use silicone grease or oil on the system. Use only oxygen compatible grease.

DO NOT: reuse Sofnolime.

DO NOT: partially refill the cartridge with Sofnolime.

DO NOT: try to prolong the life of the oxygen cells by storing in a sealed bag or in an inert gas.

DO NOT: recharge the batteries.

DO NOT: fill the oxygen cylinder with Nitrox.

DO NOT: fill the diluent cylinder with pure gasses such as Helium or Nitrogen.

DO NOT: disconnect the Auto Air hose if the Auto Air leaks air, close the cylinder valve and check the Interstage pressure.

SECTION 18

18.0 TECHNICAL DATA

Design: Rear-mounted, with over-the-shoulder twin counterlungs

Temperature Range: Operation: +4°C to + 32°C
Short term air storage (hours): -10°C to +50°C
Long term storage: +5°C to +20°C

The rebreather operating temperature range is determined at the cold end by the CO₂ duration trials, which are done at 4°C(±1). Below this temperature the duration of the CO₂ absorbent has not been empirically determined. If stored below 0°C the CO₂ absorbent and electronics will need gentle pre-heating prior to use by placing in a warmer room or by submersing the assembled rebreather with mouthpiece closed (loop sealed) until the temperature of the equipment matches the ambient temperature. Below 0°C the liquid crystal display in the handset freezes to a solid black and is unusable. Water is an essential part of the CO₂ absorption reactions (approx. 17% of Sofnolime is water), below freezing point the first reaction where CO₂ and water react to form Carbonic acid cannot take place. If a pre-breathing method of warming the Sofnolime is used, this must be done on land under supervision.

Atmospheric Range: 650 - 1080 mbar

Hydrostatic Imbalance: <1.0 kPa (10mbar) in all rotations.

Depth Limits:

40m: Max. depth with air diluent.
100m: Max. depth at which all rebreather parameters are proven: CO₂ endurance, O₂ control and work of breathing.
100m: the limit of the CE approval.
110m: max. Depth at which the work of breathing has been tested using Trimix diluent.
150m: max. Depth at which the work of breathing has been tested with an Heliox diluent.
160m: Depth at which all components are pressure tested during type approval – not during production.



WARNING! Diving deeper than 100m carries the following additional risks:

Deeper than **100m:** CO₂ endurance unknown.
Deeper than **100m:** On-board decompression invalid
Deeper than **110m:** Work of breathing with a Trimix diluent unknown.
Deeper than **130m:** Depth gauge inaccurate
Deeper than **150m:** Work of breathing with a Heliox diluent unknown.
Deeper than **160m:** Structural integrity of components unknown – the air cavity within the buzzer will implode eventually, and other components may fail.

Dimensions:	Inspiration Case: H = 650mm, W = 450mm, D = 230mm Inspiration Complete: H = 650mm, W = 450mm, D = 350mm (approx.) Evolution+ Case: H = 510mm, W = 410mm, D = 200mm Evolution+ Complete: H = 510, W = 410mm, D = 350mm (approx.) Evolution Case: H = 480mm, W = 410mm, D = 200mm Evolution Complete: H = 480mm, W = 410mm, D = 350mm (approx.)
Weight with Sofnolime:	Inspiration: Medium Counterlungs and Medium harness – 29.2kg Inspiration: Large Counterlungs and Large harness – 29.5kg Evolution+: Medium Counterlungs and Medium harness – 27.6kg Evolution+: Large Counterlungs and Large harness – 27.9kg Evolution: Medium Counterlungs and Medium harness – 24.4kg Evolution: Large Counterlungs and Large harness – 24.7kg
Harness: (For Over the shoulder Counterlung)	Multi-adjustable harness in 5 sizes, Small, Medium, Large, XL and XXL
Over the Shoulder Counterlung Volume:	Medium - 11.4 litres (5.7 litres per counterlung) Large - 14 litres (7 litres per counterlung)
Harness: (Back Mounted Counterlung)	Multi-adjustable harness in 4 sizes, Medium, Large, XL and XXL
Back Mounted Counterlung Volume:	7 litres (3.5 litres per counterlung)
Buoyancy Compensator:	16kg Wing or 22.5kg Wing (Inspiration Only)
Cylinders:	Inspiration: Two 3-litre steel cylinders (one oxygen, one diluent) Evolution+: Two 2-litre steel cylinders (one oxygen, one diluent) Evolution: Two 2-litre steel cylinders (one oxygen, one diluent) Tread sizes available: M25 x 2 or ¾”NPSM (USA)
CO ₂ scrubber:	Inspiration: 2.45kg of 797 grade Sofnolime Evolution+: 2.45kg of 797 grade Sofnolime Evolution: 2.1kg of 797 grade Sofnolime Micro-filters prevent dust from entering the breathing hoses. Water-traps virtually eliminate the possibility of a “caustic cocktail”.
First Stage	Oxygen: Intermediate Pressure - 7.5 to 8.0 bar Diluent: Intermediate Pressure - 9.0 to 9.5 bar

Battery:	3v Lithium Batteries The preferred brands are Energiser & Fujitsu Lithium 3 volt, type CR123. 4 batteries are needed in total, 2 per compartment (B1 & B2).
Handset Display:	Accuracy - ± 0.05 bar Resolution - 0.01 bar
Oxygen Control:	Two oxygen pressure setpoints, switchable from low to high and high to low as often as required, both underwater and on the surface.
Oxygen sensors:	3 Galvanic cells, Product Code: APD10 (pre October 2010) or 3 Galvanic cells, Product Code: APD12 (post October 2010)
Oxygen setpoint range	Low: 0.5 to 0.9 bar High: 0.9 to 1.5 bar
Oxygen warning level	Low: 0.4 bar High: 1.6 bar
Languages:	The VISION electronics are available in: English, German, Dutch, Italian, Spanish, French, Portuguese, Czechoslovakian and Danish
Oxygen Sensor Life:	18 months from date of manufacture
Shelf life of unused rebreather:	When stored in accordance with BS3574 the shelf life is 7 years (derived from the hoses and seals.)

Sofnolime Data

Shelf life: Refer to manufacturers packaging.

Grade: 1 - 2.5 mm Sofnolime 797 - Diving Grade

Storage: Sofnolime must be stored in a sealed container within a clean dry environment at a constant temperature (Ideally between 0 and 35°C). Storage at high temperature may cause reductions in the efficiency and effective life span of the material. Storage at sub-zero temperatures should be avoided. Correctly stored Sofnolime should maintain absorption capacity for up to five years.

Sofnolime must not be stored where it can become subject to the following:

1. Strong Sunlight.
2. Contact with any other chemicals.
3. Contact with water.
4. Atmospheric conditions with higher than normal concentrations of acidic gases.

Transport: Sofnolime contains less than 3.5% w/w sodium hydroxide and therefore is not classified as corrosive.^{1,2} Containers of Sofnolime do not need to be marked with any special hazard warning and they can be shipped by road, sea or air as non-hazardous product.

Personal Protection: Sofnolime is mildly alkaline and care must be taken to avoid contact with skin and eyes and to avoid inhalation of dust.

Spillages and Disposal: If spillage occurs granules should be swept or vacuumed up and disposed of appropriately. Any residue should be washed away with excess water. Exhausted or waste Sofnolime will contain residual alkalinity but may be disposed of in a suitable landfill site.

Ambient Pressure Diving Ltd reserves the right to alter specifications without notice.

Notes:

1. Recommendations on the Transport of Dangerous Goods, UN Forth Revised Edition, 1986.
2. CPL Regulations Authorised Approved List, Health and Safety Commission, UK, 2nd edition, 1988.
3. Manufacturer's Safety Data Sheet available from their website:
<http://www.molecularproducts.com/pdf/MSDS%20-%20Sofnolime%20%28Eng%29%20-%20v13.pdf>

SECTION 19

19.0 DANGERS INTRODUCED BY USER MODIFICATIONS

Every part of the rebreather is designed to complement the whole. Changing anything can adversely affect the product's performance. It is worth noting that many/most divers who change their product in the early days resort back to the original configuration when they have more rebreather experience.

A little bit of knowledge is a dangerous thing and the internet is full of experts who seem to know what they are talking about when in fact they don't, so please be wary and don't hesitate to contact the factory for advice.

Any changes made by the user are done so at the owner's risk unless the modification is supported in writing by the manufacturer.

It is impossible to list all modifications a user might make, the following are problems that have been seen to detrimentally affect the product's performance, sometimes with fatal consequences:

1. Do **NOT** change the 1st stages for environmentally sealed Apeks 1st stages. These sealed 1st stages boost the Interstage pressure by more than ambient pressure when at depth. This will stop the oxygen solenoid working and gas will also be lost through the pressure relief valve (the Auto Air).
2. Do **NOT** use sealant or tape to "waterproof" the blue oxygen cell covers. This prevents adequate pressure balancing leading to incorrect readings on the ppO₂ displays.
3. Do **NOT** change the mouthpiece for one with narrow bites. The bite determines how far apart the teeth are held open. If your teeth are not far enough apart the induced work of breathing is dramatic increasing retained CO₂, which in turn increases susceptibility to Nitrogen Narcosis, Oxygen toxicity, and decompression sickness.
4. If the Auto Air is removed, it must be replaced with a suitable downstream 2nd stage. Additionally, if an isolator such as the APD Flowstop or Apeks Free-Flow Control device is fitted in line with the 2nd stage, a suitable Pressure Relief valve, such as the RB17 (14bar) **MUST** be fitted to the 1st stage. Please Note: An RB17 is fitted as standard to the rebreathers diluent 1st stage.
5. 3rd party modifications are typically an area where the supplier does not fully understand the application but talks a good story, these include:
 - a. Hose connections with tiny lips so the corrugated hoses slide off too easily
 - b. 4th cell holders which leave one or more cells pointing upwards, ready to collect moisture when the diver is in the swimming position.
 - c. 4th cell holders which are not position keyed, allowing the user to rotate the whole cell assembly, putting extra strain on wiring and allowing cells to face upwards, collecting moisture.
 - d. Oxygen sensors which do not compensate properly for temperature increases through the dive. (Temperature increases occur on every dive as the scrubber warms up.)
 - e. Non-approved CO₂ absorbent. 797 Sofnolime offers the longest duration and has proven consistency and as such is the Royal Navy's and APD's first choice. APD has tested other brands and know 1st hand that the duration is reduced, significantly in most cases and that the Temp-Stik warnings occur too late with other materials.
6. Fitting a different wing BC can potentially restrict breathing hoses.
7. Fitting a stainless steel backplate can seriously affect the ability of the wing to inflate, reducing it's lift capability.
8. Take care when using the canister outside the yellow box. When you attach the scrubber to another piece of equipment, care must be taken to not over-tighten the retaining band. For example, a cam band around the outside of the scrubber could squeeze the canister and prevent the cartridge inside sliding and sealing on the O ring – causing a CO₂ bypass.

SECTION 20

20.0 DIVING DEATHS

“Whether divers die using open circuit equipment or rebreathers, they die for the same reason – they are not aware of or fail to remain within the limitations of their kit!”

The easiest way to explain this is to give you some examples:

a) Many Open Circuit sport divers die because they run out of air, many struggle to the surface and then find they can't stay afloat and drown. So what went wrong? Was running out of air the problem or was it simply their lack of planning/knowledge to deal with the situation from then on. The answer is both of course, but fundamentally the real problem was lack of awareness in knowing the equipment limitations: the gas needed to be monitored more closely during the dive and prior planning was necessary to deal with that scenario should it occur. In this example when s/he got to the surface it would have been a good idea to drop the weight-belt or inflate the BC from a 2nd air source. So, the equipment choice and combination had to be correct, the diver then had to have the ability to use the appropriate piece of equipment including the mental strength to use it. The mental strength can be improved relatively easily: practise, practise, practise.

b) Increasingly, technical Open Circuit divers die through a combination of over-weighting and breathing the wrong gas either in the shallows or deep.

c) Some leap over the side without turning the tank on, and then don't have the equipment sorted or due to lack of practise can't deploy a 2nd mouthpiece.

The above “open-circuit” instances occur a lot, 20 to 30 times per year in the UK alone!

Rebreathers bring with them new opportunities but also new limitations of which the diver must remain aware.

The following are identifiable reasons why divers die using rebreathers:

1. Over-use of the CO₂ absorbent.
2. Improper equipment assembly, followed by inadequate monitoring of system(s).
3. Inappropriate equipment selection or combinations e.g. dry suit inlet valve hose tucked under counterlungs making it impossible to disconnect in the event of a free-flow. New under-suit hindering the dry suit exhaust.
4. Failure to switch on the handsets, followed by inadequate monitoring of system.
5. Use of low oxygen percentage diluents and breathing them near the surface either through an open circuit valve or through the loop but then also failing to ensure the system is turned on & actually adding oxygen.
6. Ignoring system warnings.
7. Failing to notice lots of bubbles, failing to monitor gas pressures, only having one bail out method: Open circuit bailout is no use to you if you have no gas in the tank!

This list is not exhaustive but gives an indication of the importance of “Being aware”. Know the equipment limitations; know how it is supposed to be working, know whether it is working as you expect it to, be aware of how you feel – you are part of the loop too. Then practise and practise so you can reach all the buckles and valves and think through the problem scenarios so you are better mentally prepared to deal with issues as they arise.



Providing you are aware, rebreathers are safer than Open Circuit; they give you much longer to resolve issues before they become life threatening.

APPENDIX 1 SURFACE MENUS

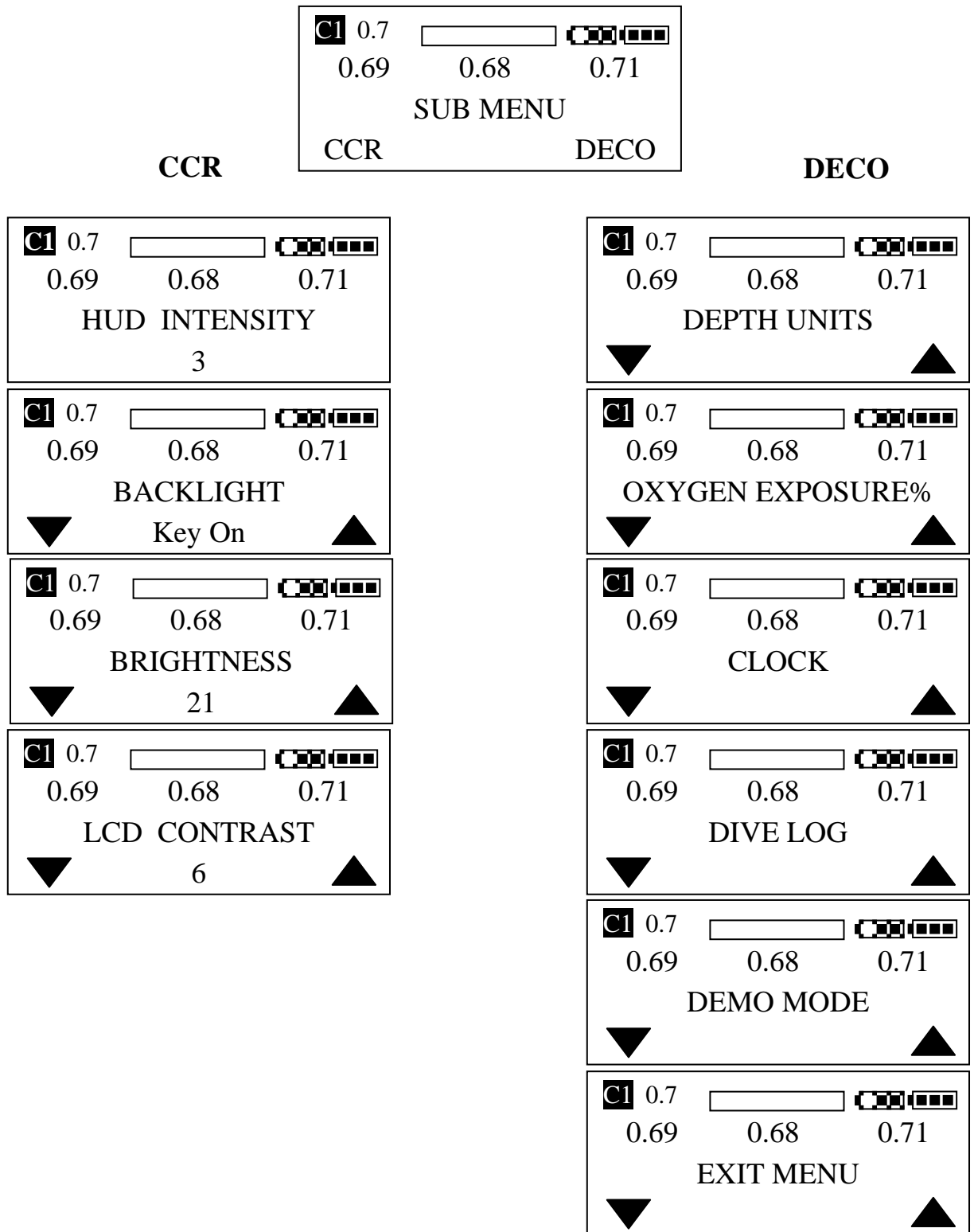

RECREATIONAL 1

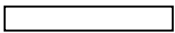



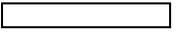

RECREATIONAL 2

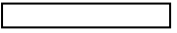

 0.7  
 0.69 0.68 0.71
 SUB MENU
 CCR DECO

CCR

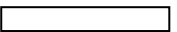

 0.7  
 0.69 0.68 0.71
 HUD INTENSITY
 3

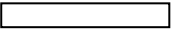

 0.7  
 0.69 0.68 0.71
 BACKLIGHT
 Key On

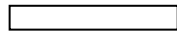

 0.7  
 0.69 0.68 0.71
 BRIGHTNESS
 21

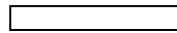

 0.7  
 0.69 0.68 0.71
 LCD CONTRAST
 6

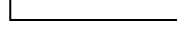

DECO

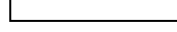

 0.7  
 0.69 0.68 0.71
 SELECT DILUENT

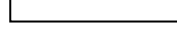

 0.7  
 0.69 0.68 0.71
 DEPTH UNITS

 0.7  
 0.69 0.68 0.71
 OXYGEN EXPOSURE%

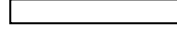
 0.7  
 0.69 0.68 0.71
 CLOCK

 0.7  
 0.69 0.68 0.71
 DIVE LOG

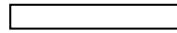
 0.7  
 0.69 0.68 0.71
 DEMO MODE

 0.7  
 0.69 0.68 0.71
 EXIT MENU

DIVE TIMER

CCR

A rectangular menu screen with a black border. At the top left is a 'Cl' icon. The top row shows '0.7' followed by a horizontal bar and a battery icon. Below this are the values '0.69', '0.68', and '0.71'. The text 'HIGH SET POINT' is centered. At the bottom are two black triangles pointing towards each other.

A rectangular menu screen with a black border. At the top left is a 'Cl' icon. The top row shows '0.7' followed by a horizontal bar and a battery icon. Below this are the values '0.69', '0.68', and '0.71'. The text 'LOW SET POINT' is centered. At the bottom are two black triangles pointing towards each other.

A rectangular menu screen with a black border. At the top left is a 'Cl' icon. The top row shows '0.7' followed by a horizontal bar and a battery icon. Below this are the values '0.69', '0.68', and '0.71'. The text 'SET POINT SWITCH' is centered. Below that is the word 'Manual'. At the bottom are two black triangles pointing towards each other.

A rectangular menu screen with a black border. At the top left is a 'Cl' icon. The top row shows '0.7' followed by a horizontal bar and a battery icon. Below this are the values '0.69', '0.68', and '0.71'. The text 'HUD INTENSITY' is centered. Below that is the number '3'. At the bottom are two black triangles pointing towards each other.

A rectangular menu screen with a black border. At the top left is a 'Cl' icon. The top row shows '0.7' followed by a horizontal bar and a battery icon. Below this are the values '0.69', '0.68', and '0.71'. The text 'BACKLIGHT' is centered. Below that is the text 'Key On'. At the bottom are two black triangles pointing towards each other.

A rectangular menu screen with a black border. At the top left is a 'Cl' icon. The top row shows '0.7' followed by a horizontal bar and a battery icon. Below this are the values '0.69', '0.68', and '0.71'. The text 'BRIGHTNESS' is centered. Below that is the number '21'. At the bottom are two black triangles pointing towards each other.

A rectangular menu screen with a black border. At the top left is a 'Cl' icon. The top row shows '0.7' followed by a horizontal bar and a battery icon. Below this are the values '0.69', '0.68', and '0.71'. The text 'LCD CONTRAST' is centered. Below that is the number '6'. At the bottom are two black triangles pointing towards each other.

A rectangular menu screen with a black border. At the top left is a 'Cl' icon. The top row shows '0.7' followed by a horizontal bar and a battery icon. Below this are the values '0.69', '0.68', and '0.71'. The text 'ELAPSED ON TIME' is centered. Below that is the text '0 hrs 29 mins'. At the bottom are two black triangles pointing towards each other.

DECO

A rectangular menu screen with a black border. At the top left is a 'Cl' icon. The top row shows '0.7' followed by a horizontal bar and a battery icon. Below this are the values '0.69', '0.68', and '0.71'. The text 'SELECT DILUENT' is centered. At the bottom are two black triangles pointing towards each other.

A rectangular menu screen with a black border. At the top left is a 'Cl' icon. The top row shows '0.7' followed by a horizontal bar and a battery icon. Below this are the values '0.69', '0.68', and '0.71'. The text 'DEPTH UNITS' is centered. At the bottom are two black triangles pointing towards each other.

A rectangular menu screen with a black border. At the top left is a 'Cl' icon. The top row shows '0.7' followed by a horizontal bar and a battery icon. Below this are the values '0.69', '0.68', and '0.71'. The text 'OXYGEN EXPOSURE%' is centered. At the bottom are two black triangles pointing towards each other.

A rectangular menu screen with a black border. At the top left is a 'Cl' icon. The top row shows '0.7' followed by a horizontal bar and a battery icon. Below this are the values '0.69', '0.68', and '0.71'. The text 'CLOCK' is centered. At the bottom are two black triangles pointing towards each other.

A rectangular menu screen with a black border. At the top left is a 'Cl' icon. The top row shows '0.7' followed by a horizontal bar and a battery icon. Below this are the values '0.69', '0.68', and '0.71'. The text 'DIVE LOG' is centered. At the bottom are two black triangles pointing towards each other.

A rectangular menu screen with a black border. At the top left is a 'Cl' icon. The top row shows '0.7' followed by a horizontal bar and a battery icon. Below this are the values '0.69', '0.68', and '0.71'. The text 'DEMO MODE' is centered. At the bottom are two black triangles pointing towards each other.

A rectangular menu screen with a black border. At the top left is a 'Cl' icon. The top row shows '0.7' followed by a horizontal bar and a battery icon. Below this are the values '0.69', '0.68', and '0.71'. The text 'EXIT MENU' is centered. At the bottom are two black triangles pointing towards each other.

NITROX

CCR

C1 0.7
0.69 0.68 0.71
HIGH SET POINT
▼ ▲

C1 0.7
0.69 0.68 0.71
LOW SET POINT
▼ ▲

C1 0.7
0.69 0.68 0.71
SET POINT SWITCH
Manual
▼ ▲

C1 0.7
0.69 0.68 0.71
HUD INTENSITY
3
▼ ▲

C1 0.7
0.69 0.68 0.71
BACKLIGHT
Key On
▼ ▲

C1 0.7
0.69 0.68 0.71
BRIGHTNESS
21
▼ ▲

C1 0.7
0.69 0.68 0.71
LCD CONTRAST
6
▼ ▲

C1 0.7
0.69 0.68 0.71
ELAPSED ON TIME
0 hrs 29 mins
▼ ▲

DECO

C1 0.7
0.69 0.68 0.71
SELECT DILUENT
▼ ▲

C1 0.7
0.69 0.68 0.71
CONSERVATISM
▼ ▲

C1 0.7
0.69 0.68 0.71
DEPTH UNITS
▼ ▲

C1 0.7
0.69 0.68 0.71
OXYGEN EXPOSURE%
▼ ▲

C1 0.7
0.69 0.68 0.71
CLOCK
▼ ▲

















C1 0.7
0.69 0.68 0.71
DIVE LOG
▼ ▲

C1 0.7
0.69 0.68 0.71
DEMO MODE
▼ ▲

















C1 0.7
0.69 0.68 0.71
EXIT MENU
▼ ▲

TRIMIX

CCR

 0.7	<input type="text" value="0.68"/>	
0.69	0.68	0.71
HIGH SET POINT		
▼ ▲		
 0.7	<input type="text" value="0.68"/>	
0.69	0.68	0.71
LOW SET POINT		
▼ ▲		
 0.7	<input type="text" value="0.68"/>	
0.69	0.68	0.71
SET POINT SWITCH		
Manual ▼ ▲		
 0.7	<input type="text" value="0.68"/>	
0.69	0.68	0.71
HUD INTENSITY		
3 ▼ ▲		
 0.7	<input type="text" value="0.68"/>	
0.69	0.68	0.71
BACKLIGHT		
Key On ▼ ▲		
 0.7	<input type="text" value="0.68"/>	
0.69	0.68	0.71
BRIGHTNESS		
21 ▼ ▲		
 0.7	<input type="text" value="0.68"/>	
0.69	0.68	0.71
LCD CONTRAST		
6 ▼ ▲		
 0.7	<input type="text" value="0.68"/>	
0.69	0.68	0.71
ELAPSED ON TIME		
0 hrs 29 mins ▼ ▲		

DECO

 0.7	<input type="text" value="0.68"/>	
0.69	0.68	0.71
SELECT DILUENT		
▼ ▲		
 0.7	<input type="text" value="0.68"/>	
0.69	0.68	0.71
GRADIENT FACTORS		
▼ ▲		
 0.7	<input type="text" value="0.68"/>	
0.69	0.68	0.71
DEPTH UNITS		
▼ ▲		
 0.7	<input type="text" value="0.68"/>	
0.69	0.68	0.71
OXYGEN EXPOSURE%		
▼ ▲		
 0.7	<input type="text" value="0.68"/>	
0.69	0.68	0.71
CLOCK		
▼ ▲		
 0.7	<input type="text" value="0.68"/>	
0.69	0.68	0.71
DIVE LOG		
▼ ▲		
 0.7	<input type="text" value="0.68"/>	
0.69	0.68	0.71
DEMO MODE		
▼ ▲		
 0.7	<input type="text" value="0.68"/>	
0.69	0.68	0.71
EXIT MENU		
▼ ▲		

APPENDIX 2 Determining The Oxygen Purity (When The Gas Quality Is Not Certified)

Section A

It is possible to analyse the gas using an independent oxygen analyser, which has been calibrated on pure oxygen. However, when travelling, there is little point in taking another analyser with you when you already have three built into the rebreather. Calibrate the rebreathers cells on a known gas source before departure and on reaching the destination, select NO to any calibration prompts. In the event of a MUST CALIBRATE warning, select NO but then see Section B below.

Section B - Flush with Oxygen:

Open the mouthpiece and continually press the manual oxygen inflator, located on the exhale counterlung. When the cell readings have stabilised, which will take approx. 20 seconds of continual injection, record the cell readings on the oxygen controller. When the system is flushed with the available oxygen the three subsequent ppO₂ readings, one for each cell, will show the product of the oxygen percentage and the ambient pressure. If the ambient pressure at the new location is known then the exact oxygen percentage in the gas supplied may be calculated as follows:

$$\frac{\text{Ambient Pressure (bar)} \times \text{Oxygen Percentage in Gas cylinder}}{100} = \text{Displayed ppO}_2$$

If: ppO₂ displayed = 0.85
Ambient pressure = 1036 mbar (1.036 bar)
Quality of gas supplied = unknown = Z

$$\frac{1.036 \times Z}{100} = 0.85$$

$$Z = \frac{0.85 \times 100}{1.036}$$

$$Z = 82\% \text{ (at the surface)}$$

The apparatus may be recalibrated using the now known oxygen content of the gas supplied. To recalibrate, switch the controller off and then on again. When diving with less than 100% oxygen, buoyancy control will be more difficult as more gas must be injected via the solenoid valve and it may take the controller longer to reach the desired setpoints.

APPENDIX 3 Self Check Questions and Answers

a. **What are the risks when you first enter the water?**

The biggest danger is jumping in with the unit turned off. Even with the new auto-activation feature, automatic switch on cannot be guaranteed. A quick look at the displays, wrist and HUD, verifies that all is functional and the cell values change as you breathe. It is not unknown for divers to jump in without turning on the diluent or ensuring the inflator hose is properly connected. Just before you jump in - always press the diluent inflator button. If you look at the diluent's pressure gauge at the same time you will see if the tank valve is open enough too. (If the needle drops when you press the inflator the tank valve needs opening more).

b. **What risks may become apparent during a surface swim prior to the dive?**

Surface swims can be hard work. If the oxygen cylinder is empty or switched off or the oxygen solenoid valve is faulty the oxygen level can drop quite rapidly. It is essential to look at the oxygen display every minute.

c. **During the descent what is usually seen on the ppO₂ display?**

The ppO₂ will rise during the descent.

d. **How often do you expect the solenoid to operate during the descent?**

It is very rare for the solenoid to operate during the descent. The solenoid only operates if the ppO₂ drops below the setpoint. The increasing ambient pressure keeps the ppO₂ above the 0.7bar set point, effectively preventing the solenoid from opening.

e. **Once below 23m what would be the effect of staying on the low (0.7bar) setpoint?**

Below 23m the diver experiences more narcosis and has a greater decompression obligation than open circuit air! This is particularly dangerous if the diver's decompression planning is based upon a 1.25 bar setpoint.

f. **Once on the bottom how often would you expect the solenoid to operate and for how long would the oxygen inject?**

When at a steady depth the oxygen controller only adds the oxygen that you metabolise, so you should expect short burst oxygen injections approximately every 30 seconds. The deeper you go the shorter the bursts and longer the interval. So if you hear a long oxygen inject look at the displays.

g. **What is the effect of the ppO₂ of adding diluent to the loop, for example after mask clearing?**

Adding diluent reduces the ppO₂ if the unit is running normally at 1.3 bar. The degree of reduction will vary with depth.

h.	If a diluent flush is carried out at:	10m what will be the ppO ₂ in the loop?	0.42 bar
		20m what will be the ppO ₂ in the loop?	0.63 bar
		30m what will be the ppO ₂ in the loop?	0.84 bar
		40m what will be the ppO ₂ in the loop?	1.05 bar

i. **How often should you check your ppO₂ whilst on the bottom?**

Once per minute

j. **Why is it important to check your ppO₂ prior to the ascent?**

During the ascent the ppO₂ will drop. If you have a low ppO₂ in the loop the simple act of rising 3m may be sufficient to lower the ppO₂ sufficiently to cause a loss of consciousness.

k. **As you ascend how often would you expect the solenoid to operate and for how long and how would this vary with ascent speed?**

During the ascent the ppO₂ drops, sometimes by as much as 0.2 bar. To counteract this, the solenoid operates for longer. Typically you might hear 3 second bursts with 6-second intervals. During fast ascents the ppO₂ drops more quickly, therefore, the O₂ solenoid will open for longer bursts but still with the 6 second interval between oxygen injections.

For further self-test questions see Fred's questions, downloadable from www.apdiving.com

APPENDIX 4

Decompression Tables

The table below is reproduced from DDPlan.

A copy of DDPlan software can be downloaded from www.drogon.net

DDPlan's table generator is an excellent feature, which greatly reduces the potential for mistakes when dive-planning.

Ascent speed - 10m/min

Bottom time = time from leaving the surface to time leaving the bottom.

Decompression is an inexact science. All formulae and tables in existence, including this one, cannot guarantee the user will not incur decompression sickness. Do the deepest dive first and avoid yo-yo dive profiles.

Using ppO₂ setting of 1.3 bar. (Worst case accuracy assumed – ppO ₂ = 1.25 bar)					Open Circuit Bail Out on Air, with a gas switch at 4.5m to 99% oxygen. Assuming REBREATHING fails during the last minute of bottom time.		
DEPTH	BOTTOM TIME	9m	6m	4.5m	9m	6m	4.5m
20m	140 150 170						2 3 4
25m	60 70 80 90 100 120			5 7 9 12 16		1	3 6 8 11 13 17
30m	30 40 50 60 70			6 9 13 17		1 1 3	3 5 9 12 16
35m	30 40 50		1 5	8 12 13	1 4	1 3 4	6 10 15

Intentionally Blank

APPENDIX 5

Buddy Clean Data Sheet

Section 1A – Product Identification

Trade Name: Buddy Clean Disinfectant/ Cleanser
Product Use: Hard Surface Disinfection and Cleaning
Chemical Type: Halogenated Tertiary Amine

Section 1B – Supplies Identification

Name and Address: Ambient Pressure Diving Ltd.
Water-ma-Trout Industrial Estate
Helston,
Cornwall, UK.
TR13 0LW
Telephone No.: 01326 563834
Fax No.: 01326 573605

Section 2 – Hazardous Ingredients

Hazardous Ingredients: None
Percentage by Weight: N/A
LD50 of Material: >4000mg/kg

Section 3 – Physical Data

Physical State: Liquid
Appearance & Odour: Colourless, slight natural colour, Available green with citrus fragrance
Evaporation Rate: As Water
Boiling Point: 110°C
Freezing Point: -20°C
% Volatile (by weight): >95%
Solubility in Water (20°C): Soluble
pH: 5 approximately
Specific Gravity: 1.02 @ 20°C

Section 4 – Fire & Explosion Data

Flammability: Non-Flammable
If Yes, Under Which Conditions: None

Section 5 – Reactivity Data

Chemical Stability:	Stable
Incompatibility:	If mixed with strong Alkalis, may neutralise or reduce disinfectant qualities
Hazardous Decomposition Products:	If burnt may produce irritating fumes

Section 6 – Toxicological Properties

Exposure Route:	Degree of Hazard
– Skin Contact:	Low: Concentrate may act as a mild degreasant to sensitive skin
– Eye Contact:	Low: Will Cause Irritation but no serious damage
– Inhalation Acute:	Low: No significant hazard
– Inhalation Chronic:	Low: No significant hazard
– Ingestion:	Low: Substantial ingestion may cause irritation to mouth, throat and digestive tract

Section 7 – Preventative Measures

Personal Protective Equipment: None required

Eye Protection: Avoid contact with eyes

Leak & Spill Procedure: Soak up onto inert material or may be flushed to drain with copious amounts of water

Handling Procedures: Ensure good industrial hygiene

Storage Requirements: Store between 0-30°C in dry conditions

Section 8 – First Aid Measures

State of Caution

Inhalation: Non-Toxic: avoid long term inhalation of neat liquid. Remove to fresh air.

Eye Contact: Rinse eyes with water. Seek medical advice if necessary.

Skin Contact: Wash affected area with soap and water.

Ingestion: Do NOT induce vomiting. Give copious milk or water. Seek medical advice where necessary.

Section 9 – Concentration

Buddy Clean is a neat solution and should be diluted:

Dilution rate: Light soiling - 1:100
Heavier soiling - 1:50 with 20 minutes soak period.

If used in breathing circuits, rinse thoroughly with fresh water and allow to dry.

BUDDY Clean is not FDA approved for use in America; Silent Diving Systems LLC (www.silentdiving.com) should be consulted for approved disinfectant in the USA.



TO WHOM IT MAY CONCERN

We hereby certify that the Soda Lime (Medisorb & Absorber units) manufactured by Molecular Products Ltd contains less than 4% (four per cent) Caustic Soda (NaOH) is classified as non-hazardous and that it is not restricted for transport.

The label showing the Irritant symbol is a label for use of the product – not for transport.

Signed:

Natalie Sewell
Sales Support

Molecular Products Ltd

Mil End, Thuxted, Essex
CM16 2LT, United Kingdom

T +44 (0)1371 830676
F +44 (0)1371 830998

E sales@molprod.com
W www.molecularproducts.com

Registered office as above Reg No 02721125 England. A member of Molecular Products Group plc





Intentionally Blank

APPENDIX 7 Sofnolime® data sheet

<h2>Safety Data Sheet</h2>		 molecular
Product name: Sofnolime®	Safety Data Ref: 23 Initial issue date: 09 March 2012 Revision date: 18 October 2012 Version number: 14	

1 IDENTIFICATION OF SUBSTANCE / PREPARATION AND OF THE COMPANY	
1.1 Product identifier	Soda Lime (Sofnolime, Medisorb, Soda Lime, Soda Lime HC, Easysorb, CHIRAlime, Limepak, Medisize, Limedic, Aneslime)
1.2 Relevant use(s)/misuse(s)	As an absorbent for carbon dioxide and other acidic gases
1.3 SDS supplier	Molecular Products Ltd, Parkway, Harlow Business Park, Harlow, Essex, CM19 5FR, UK
1.4 Emergency contact	+44 (0) 1279 445111 (office hours) / +44 (0)1270 502891 (24 hour emergency number) trevor@rising-hsande.co.uk (competent person email)

2 HAZARDS IDENTIFICATION			
2.1 Classification of the substance or mixture (i.e. Sofnolime)			
2.1.1 Classification according to Regulation (EC) No 1272/2008 (CLP/GHS) – see section 11	2.1.2 Classification according to EC – see section 11		
Skin irrit. 2	H315	Xi	R36/38
Eye irrit. 2	H319		
2.1.3 Labelling in accordance with EC Directives 67/548/EEC and 1999/45/EC (CHIP 4)			
2.2 Labelling elements			
2.2.1 Physicochemical	According to experience, the product is considered to have no adverse physicochemical properties if handled in the correct manner		
Health	 Irritating to eyes and skin		
Environmental	According to experience, the product is considered to have no adverse affect on the environment if handled in the correct manner		
2.2.2 Labelling in accordance with EC Regulation No 1272/2008 (CLP/GHS)			
Pictogram		Signal word	WARNING
Hazard statements			
H315	Causes skin irritation		
H319	Causes serious eye irritation		
Precautionary statements			
P280	Wear protective gloves/protective clothing/eye protection/face protection		
P314	Get medical advice/attention if you feel unwell		
P302/352	If on skin: wash with plenty of soap and water		
P305/351/338	If in eyes: rinse cautiously with water for several minutes. Remove contact lenses, if present, and easy to do. Continue rinsing		
P332/313	If skin irritation occurs: get medical advice/attention		
2.3 Other hazards			
None known			

3 COMPOSITION / INFORMATION ON INGREDIENTS				
Chemical characterisation	Solid bases plus additives – see section 16 The CHIP/CLP classifications required in this section are related to that of the product supplied. To comply with the legislation the classification of the relevant ingredients of the product, as if they were present at 100%, must be outlined. Where ingredients are present in the product at very low concentrations the level of risk to the user is reduced, hence the reason that the classifications for the individual components and the product are different			
Chemical name	CAS-No	EINECS/ELINCS	Classification	Concentration
Sodium Hydroxide	1310-73-2	215-185-5	CHIP: C: R35 CLP: Skin Corr. 1A H314	<3%
Calcium Hydroxide	1305-62-0	215-137-3	CHIP: Xi: R38. 41 CLP: Skin Irrit. 2 H315 Eye Damage 1 H318 WEL assigned	>75%

4 FIRST AID MEASURES		
4.1	Description of measures	
	Inhalation	Remove casualty to fresh air and provide warmth and rest
	Skin contact	Clean areas of skin affected immediately with soap and plenty of water. If necessary, seek medical advice
	Eye contact	Immediately wash out eye thoroughly with plenty of water until irritation subsides; consult an eye specialist/ophthalmologist
	Ingestion	Unlikely route of exposure. But if product is swallowed, do not induce vomiting. Drink plenty of water and, if necessary, seek medical advice
4.2	Most important effects/symptoms	None known
4.3	Immediate/special treatment	Treatment as described above

5 FIRE FIGHTING MEASURES		
5.1	Extinguishing media	To suit local surroundings (e.g. chemical powder, carbon dioxide, dry sand, water)
5.2	Special hazards	None known
5.3	Advice for fire fighters	Self-contained breathing apparatus may be required

6 ACCIDENTAL RELEASE MEASURES		
6.1	Personal precautions	Adhere to personal protective measures
6.2	Environmental precautions	Do not allow to get into waste water or waterways; if this occurs, inform the relevant water authority at once
6.3	Methods and materials for cleaning up	In the event of spillage, take up mechanically (e.g. sweep or vacuum up) into tightly closed containers. Adhere to personal protective measures. Flush any remainder with plenty of water. Label container and dispose of as prescribed
6.4	Reference to other sections	See section 8 for personal protective equipment

7 HANDLING AND STORAGE		
7.1	Precautions for safe handling	Handle in accordance with good hygiene and safety practice. Avoid the raising and deposition of dust
7.2	Conditions for safe storage	Ensure adequate ventilation of the storage area. Keep containers tightly closed, cool (0-35°C) and dry, avoiding direct sunlight
7.3	Specific end use(s)	As an absorbing agent

8 EXPOSURE CONTROLS / PERSONAL PROTECTION					
8.1	Workplace Exposure Limits (WELs) have been assigned by the HSE (EH40/2005)				
	STEL (15 mins)	ppm	2	mg/m ³	Data for sodium hydroxide
	LTEL (8 hour TWA)	ppm	5	mg/m ³	Data for calcium hydroxide
8.2	Exposure controls				
	Engineering controls	Provide adequate ventilation (e.g. local exhaust ventilation)			
	Personal protection	Observe normal standards for handling chemicals Wash hands before breaks and after work Avoid inhalation of dust if raised Wear personal protective equipment appropriate to the task (see below)			
	Eye protection	Safety goggles if risk of eye contamination			
	Skin protection	Suitable gloves (consider your own risk assessment; e.g. breakthrough times, rates of diffusion and degradation, tasks undertaken)			
	Respiratory protection	Approved dust mask or respirator (e.g. EN 149:2001 FFP3) for dust if ventilation is insufficient			
	Other protection	Protective overalls			

9 PHYSICAL AND CHEMICAL PROPERTIES				
9.1	Basic physical and chemical properties			
	Physical form	Solid	Colour	White or coloured
	Odour	Odourless	pH	12-14
	Boiling pt/range	Not determined	Melting pt/range	Not determined
	Flash point	Not applicable	Relative density	~ 0.9g/cm ³
	Water solubility	Slight		
9.2	Other information	None		

10 STABILITY AND REACTIVITY		
10.1	Reactivity	Heat is generated if exposed to acids
10.2	Chemical stability	Stable under normal conditions of handling
10.3	Hazardous reactions	Hazardous polymerisation will not occur
10.4	Conditions to avoid	Contact with air – formation of calcium and sodium carbonate
10.5	Incompatible material	Chloroform, trichloroethylene
10.6	Hazardous decomposition products	None

11 TOXICOLOGICAL INFORMATION			
11.1 Information on toxicological effects			
Acute toxicity	LD (lo) rabbit (oral)	500 mg/kg	Data for sodium hydroxide
	LD ₅₀ rat (oral)	>7000 mg/kg	Data for calcium hydroxide
Dermal compatibility	No data available		
Mucous membrane	No data available		
Further information	Although using the 'conventional method' under CHIP or 'specific concentration' limits under CLP, the product classification would be 'corrosive', using EU official <i>in vitro</i> tests on the whole product, it was found to be irritating to eyes and skin, not corrosive		

12 ECOLOGICAL INFORMATION					
12.1	Toxicity	LC ₅₀	Aquatic organisms	mg/l	No data available
12.2	Degradability	Not determined	12.3	Bioaccumulative potential	Not determined
12.4	Mobility in soil	Not determined	12.5	PBT/vPvB assessment	Not applicable
12.6	Other adverse effects	None known – converts to naturally occurring minerals			

13 DISPOSAL CONSIDERATIONS	
Advice on disposal	If possible, recycle to supplier or approved recycling company. If not (e.g. designated as waste), dispose of in accordance with national and local authority regulations, e.g. The Hazardous Waste (England & Wales) Regulations 2005
Contaminated packaging	Treat empty containers in the same way as the product. If possible wash out thoroughly and recycle

14 TRANSPORT INFORMATION					
14.1	United Nations number (ADR, IMDG, IATA)	Not classified	14.2	Proper shipping name (ADR, IMDG, IATA)	Not classified
14.3	Transport class(s) (ADR, IMDG, IATA)	Not classified	14.4	Packing group (ADR, IMDG, IATA)	Not classified
14.5	Environmental hazards (ADR, IMDG, IATA)	The product should not be marked as a marine pollutant	14.6	Special procedures (ADR, IMDG, IATA)	Not applicable
14.7	Transport in bulk	Not applicable			

15 REGULATORY INFORMATION		
15.1	Safety, health and environmental regulations	The product is classified in accordance with the Chemicals (Hazard Information and Packaging for Supply) Regulations (CHIP 4) and EC Regulation 1272/2008 (CLP). Other regulatory information and provisions are not applicable for this product
15.2	Chemical safety assessment	Not applicable

16 OTHER INFORMATION			
Further information	The SDS has been revised in accordance with EC Regulation 1272/2008 (CLP)		
	Comply with COSHH Regulations		
Hazard statements and Risk phrases referred to in sections 2/3			
H314	Causes severe skin burns and eye damage	R35	Causes severe burns
H315	Causes skin irritation	R36/38	Irritating to eyes and skin
H318	Causes serious eye damage	R41	Risk of serious damage to eyes
H319	Causes serious eye irritation		
Sources of data	Other suppliers' safety data sheets, Annex VI of the CPL Regulation (EC) No 1272/2008, EH40 (2005) OECD 431, 2004 Testing of chemicals, <i>in vitro</i> skin corrosion, human skin test model		
Date of issue	18/10/2012		
This information is based on our present state of knowledge and is intended to describe our products from the point of view of the safety requirements. It should not be construed as guaranteeing specific problems			

This is a guide ONLY, pointing out the limitations of the equipment. It is not the intention of this manual to teach the diver how to dive using a pre-mixed helium based diluent, a separate course should be undertaken for that, but it is essential to prepare a diluent with a suitable Equivalent Nitrogen Depth (END) and a ppO₂ of between 1.0 and 1.2 bar if the diluent were to be breathed open circuit on the bottom or manually flushed through the breathing circuit.

Setpoint Considerations:

The maximum setpoint should be 1.3 bar. Avoid using a higher setpoint. If a higher setpoint is used the high O₂ alarm will be triggered occasionally – the deeper you are the more oxygen molecules are injected per solenoid inject, giving slightly larger spikes per injection than would be experienced at shallower depths. Additionally, a higher setpoint during the “bottom” phase of a dive gives minimal benefit in decompression times but significantly reduces the oxygen toxicity safety margin.

Diluent Considerations:

There are three considerations when choosing the diluent:

1. The ppO₂ of the diluent at the deepest planned depth, must not exceed 1.3 bar to allow effective diluent flushing. 1.0 to 1.2 bar ppO₂ is common.
2. The ppN₂ of the diluent affects the Narcosis and affects the density of the gas within the loop. The increased density increases the work of breathing and reduces the scrubber duration. Increased work of breathing increases retained CO₂, which in turn increases the effects of Narcosis, oxygen toxicity and decompression sickness. A ppN₂ of 3.16 bar is suitable to 70m. Beyond 70m the ppN₂ must be reduced: e.g. a ppN₂ of 2.68 bar is suitable to 100m. The table below shows suitable Trimix and possible HeliAir mixes.

Depth	END	Max. PN ₂	PO ₂	Trimix, (O ₂ /Helium)	HeliAir, (O ₂ /Helium)
50	30	3.16	1.3	"21:26"	"15:29"
60	30	3.16	1.3	"18:36"	"13:37"
70	30	3.16	1.3	"16:44"	"11:45"
80	28	3.002	1.3	"14:52"	"10:52"
90	26	2.844	1.3	"13:59"	"9:58"
100	24	2.686	1.3	"11:64"	"7:67"

3. The diver must carry a diluent that is life supporting (respirable) when breathed open circuit at the surface. The deeper mixes are NOT respirable at the surface so it is clear an additional cylinder with a higher oxygen content must be provided and care needs to be taken in configuration and marking to ensure the diver doesn't use the deep diluent's 2nd stage when close to the surface.

The INSPIRATION, EVOLUTION and EVOLUTION+ rebreathers are a dual-use product and whether new or 2nd hand requires an export license if shipped outside the Country of use.

Critically there is an exception to this requirement, detailed as a footnote in Category 8A002q. At September 2003 the UK's Department of Industry specified the following:

Section 8A 002q: self-contained, closed or semi-closed circuit (rebreathing) diving and underwater swimming apparatus. *Note: 8A002q does not control an individual apparatus for personal use when accompanying its user.*

For the latest information see: <http://www.dti.gov.uk/export.control/>

Individual Countries may have alternative export license requirements and users should establish these requirements for themselves.

RoHS Statement (Restriction of Hazardous Substances)

Ambient Pressure Diving Ltd. is committed to complying with all applicable laws and regulations, including the European Union Restriction of Hazardous Substances (RoHS) Directive that restricts the use of hazardous materials in electronics products. The company continues to work toward the reduction of RoHS materials in our products which are subject to the RoHS Directive, except where it is widely recognized that there is no technically feasible alternative.

WEEE Compliance (Waste Electrical and Electronic Equipment)

On January 27, 2003 the European Parliament and the Council of the European Union authorized Directive 2002/96/EC or WEEE (Waste Electrical and Electronic Equipment). The aim of the directive is to halt the growing volume of electrical and electronic (EEE) waste disposed of in landfill sites.

Ambient Pressure Diving Ltd. has evaluated its product lines against the criteria set forth in the WEEE directive. As required by the legislation, any Ambient Pressure Diving Ltd product covered by the directive and sold in the EU after August 13, 2005 is marked with the Wheeled Bin symbol, inserted in the user manual or on the packaging. Ambient Pressure Diving Ltd. uses the symbol based on the EN 50419:2005 CENELEC standard. The bottom bar certifies the product concerned was placed on the market after August 13, 2005.

Disposal of Electrical and Electronic Waste

At the end of the products life, customers should return their electrical and electronic waste manufactured by Ambient Pressure Diving Ltd back to the company where it can be recycled and treated appropriately. Any EEE replaced during a factory repair will be handled appropriately by the company.



Pre Dive /Assembly Check List

Perform the checks and tick the appropriate box prior to diving	<input checked="" type="checkbox"/>
Fill scrubber cartridge with fresh Sofnolime (797) and place in scrubber	<input type="checkbox"/>
Ensure Scrubber O ring is clean and undamaged and lubricate with O2 compatible grease	<input type="checkbox"/>
Place the spacer ring on top of scrubber cartridge, push down on ring and release ensuring free movement	<input type="checkbox"/>
Switch on handset and check cells and batteries pass power on tests. Switch off.	<input type="checkbox"/>
Fit lid to scrubber and assemble into rebreather.	<input type="checkbox"/>
Analyse diluent and O ₂ cylinders and place in rebreather, connecting the first stages securely	<input type="checkbox"/>
Holding solenoid hose away from eyes, briefly open the O ₂ cylinder valve and close again, which clears debris/water from the oxygen hose. Connect solenoid hose to scrubber fitting.	<input type="checkbox"/>
Open cylinder valves and check diluent and oxygen cylinder pressures, refill if necessary.	<input type="checkbox"/>
Check function of valves and bailout systems.	<input type="checkbox"/>
Check the Oxygen's Interstage Pressure (it should be 7.5 bar). If the pressure is higher the solenoid may not open, if the pressure is lower the solenoid may not close.	<input type="checkbox"/>
Confirm correct operation of non-return valves in mouthpiece and re-connect to T-pieces	<input type="checkbox"/>
Check operation of mouthpiece and direction of gas flow through convoluted hoses, it should exhale towards the diver's right shoulder.	<input type="checkbox"/>
Carry out positive and negative pressure tests (see Section 1.14)	<input type="checkbox"/>
Verify sufficient absorbent time remaining for planned dive	<input type="checkbox"/>
Switch on electronic handset and proceed to dive mode	<input type="checkbox"/>
Verify proper computer function, ppO ₂ displays must move with gas changes.	<input type="checkbox"/>
Verify correct calibration of O ₂ sensors	<input type="checkbox"/>
Verify Battery levels are sufficient for planned dive	<input type="checkbox"/>
Flush with air and check for low oxygen warning display and buzzer	<input type="checkbox"/>

Pre-Breathe Sequence

Prior to immersion the following pre-breathe check should be conducted to confirm the correct operation of the Rebreather.

	
Confirm operation of diluent and oxygen inflators (and ADV, if fitted), watching HP gauges. (If the pressure dips, open the cylinder valve more).	
Confirm operation of bailout systems	
Ensure both counterlungs are fastened down with the Fastex buckles and crotch strap is secure	
Select the LOW setpoint	
Ensure the ppO ₂ drops rapidly as you exhale into the loop and check for slow changing cell values	
Confirm the O ₂ control system properly maintains the setpoint for a minimum of 3 minutes	
Confirm CO ₂ absorbent is functioning properly (pay attention for symptoms of Hypercapnia)	
If Temp-stik is fitted pre-breathe until at least the left hand block on the display is black.	
Ensure correct diluent is selected	
If setpoint change AUTO is selected, ensure the switch depth is appropriate for planned dive	
Ensure the Conservatism (Nitrox) or Gradient Factors (Trimix) settings are appropriate for planned dive	
Check the mouthpiece valve is fully open. Partially open will allow water in.	

In-Water Checks and Important Procedures

	
After entering the water and before descending, ensure the oxygen controller is functioning.	
Ask your buddy to do a "bubble check" at 6m (20ft) on your equipment. It is easier to abort the dive at 6m (20ft) and surface to fix any leaks.	
Add DILUENT during the descent. It is dangerous to confuse the diluent and oxygen inflators. Adding oxygen will cause a high ppO ₂ in the breathing loop	
Once on the bottom, or below 20m, switch the setpoint to the HIGH setpoint. If the AUTO setpoint facility is selected, on the bottom, ensure the unit HAS changed to the HIGH setpoint.	
Ensure the HIGH setpoint is maintained throughout the dive and is appropriate for the planned decompression schedule.	
During the ascent, dump the expanding gas by pulling the exhaust valve override or by exhaling around the mouthpiece, or through the nose. No later than 4m, switch back to the low setpoint.	
KNOW YOUR ppO₂ AT ALL TIMES !	

Post-dive actions

	
Stand the unit upright or lean gently forward onto the counterlungs. DO NOT lay down on its back.	
Remove the mouthpiece and hose assembly by unscrewing from the T-pieces, drain and if required, rinse with fresh water, ensuring the non-return valves work properly prior to storage	
Check the scrubber for water and drain off excess	
Dry the scrubber lid shaking off (gently) excess water and leave to air dry. Once dry, re-assemble to the scrubber.	
Remove the unit from direct sunlight (put a towel over it, if there is no shade)	
Leave cylinder valves open until all the day's diving is finished	
Conduct post-dive maintenance: Rinse counterlungs, mouthpiece, valves and BC with fresh water.	

