

# WNIPT

April 2016 vol.29 no.10  
PP100007403

**WHAT'S NEW IN  
PROCESS TECHNOLOGY**

**AUTOMATION + CONTROL +  
INSTRUMENTATION**



**Another Layer of Protection:  
Moore Industries' Alarm Trip Reliability with  
Intrinsically-Safe Field Connections**

**MOORE  
INDUSTRIES**  
WORLDWIDE

Entry-level controller.

High-end controller.

# The best of both worlds.

CX5100 Embedded PCs: The ideal price-to-performance ratio for PLC & Motion Control.



CPU: ARM Cortex™-A8



CPU: Intel® Atom™ multi-core



CPU: Intel® Core™ microarchitecture

[www.beckhoff.com.au/CX51xx](http://www.beckhoff.com.au/CX51xx)

With the CX5100 Embedded PC series, Beckhoff has established a new, cost-effective control system category for universal use in automation applications. The three fanless, DIN rail-mountable CPU versions offer users the high computing and graphics performance of the Intel® Atom™ multi-core generation with the added benefit of lower heat dissipation. The basic configuration includes a direct I/O interface for Bus Terminals or EtherCAT Terminals, two 1,000 Mbit/s Ethernet interfaces, a DVI-I interface, four USB 2.0 ports and a multi-option interface that can be equipped to accommodate a wide range of fieldbuses.

- IPC
- I/O
- Motion
- Automation



CX5120:  
Intel® Atom™ CPU,  
1.46 GHz, single-core



CX5130:  
Intel® Atom™ CPU,  
1.75 GHz, dual-core



CX5140:  
Intel® Atom™ CPU,  
1.91 GHz, quad-core

New Automation Technology **BECKHOFF**

WHAT'S NEW IN  
PROCESS TECHNOLOGY  
APRIL 2016

## CONTENTS

- 4 The control system kill chain – Part 1
- 8 New products
- 10 Hot products online
- 20 Industrial wireless challenges overstated
- 30 Wireless networks in the water and wastewater industries
- 35 Water: for liveable communities and sustainable industries
- 44 Meeting emerging challenges in manufacturing with lightweight robotics – Part 2
- 50 Cybersecurity needs focus in a connected world



### ON THE COVER



The SPA<sup>2</sup>IS programmable alarm trip with built-in intrinsically safe (IS) field connections is the newest addition to Moore Industries' reliable family of alarm trips, joining the SPA<sup>2</sup> Programmable Alarm Trip, and STA Functional Safety Logic Solver.

With the new SPA<sup>2</sup>IS, separate and costly intrinsically safe barriers are no longer required when connecting inputs from the most hazardous areas. Powered by a universal AC/DC power supply and accepting a wide range of signals including current, voltage, RTDs and thermocouples, the SPA<sup>2</sup>IS is a combination alarm trip and temperature transmitter.

Also featured are dual- and quad-independent and individually configurable alarm relay outputs based on user-set high/low limits. Programmable through free PC software or front-panel push-buttons, the SPA<sup>2</sup>IS offers a large 5-digit display, which can be set to variable outputs.

Facilities employing intrinsic safety as a method of hazardous area protection will find the SPA<sup>2</sup>IS a cost-effective, complete alarm solution that eliminates the need for galvanically isolated intrinsically safe barriers and related power supplies. Fewer components translates to reduced wiring, space and maintenance costs while eliminating the burden of heat dissipation or cooling considerations, which are often required with intrinsic safety barrier marshalling cabinets. Visit the website to learn more and download the SPA<sup>2</sup>IS data sheet at [www.miinet.com/spa2is](http://www.miinet.com/spa2is).

Moore Industries Pacific Inc  
[www.miinet.com](http://www.miinet.com)

 **MOORE  
INDUSTRIES**  
WORLDWIDE

### NOW in DIGITAL!

Your copy of *What's New in Process Technology* is now available as an online eMag.  
[www.processonline.com.au/magazine](http://www.processonline.com.au/magazine)



# THE CONTROL SYSTEM KILL CHAIN

UNDERSTANDING EXTERNAL  
ICS CYBER THREATS

**PART 1**

*Glenn Johnson, Editor*



Understanding the approach a sophisticated external cyber attack adversary may take in infiltrating an industrial control system helps organisations defend against the unthinkable.

**T**he advent of Industry 4.0 and equivalently named industrial technology initiatives has resulted in an increased drive towards implementing the already accepted idea of the interconnection of industrial control systems with business IT systems and the internet. Previous ideas that industrial control systems (ICS) were somewhat impervious to outsider threats (due to their custom and proprietary nature and isolation) are now a thing of the past, and organisations are having to come to an understanding of how to take advantage of the 'emerging fourth industrial revolution' while mitigating potential cyber threats.

This article is a review of some of the currently published literature on the subject of ICS cyber threats, and is intended to provide a general overview of the threat environment as it pertains to industrial organisations and their control systems.

According to the Australian Cyber Security Centre (ACSC), the "cyber threat to Australian organisations is undeniable, unrelenting and continues to grow. If an organisation is connected to the Internet, it is vulnerable". The 'Australian Cyber Security Centre Threat Report 2015' also states:

"Cyber adversaries are aggressive and persistent in their efforts to compromise Australian networks and information. They are constantly improving their tradecraft in an attempt to defeat our network defences and exploit new technologies.

"Australia is an innovative country with a globally important resources sector. We are a regional leader with global interests and important partnerships. This makes Australia a target-rich environment for cyber adversaries.

"There are a range of cyber adversaries motivated to target Australian networks."

A 'cyber adversary' is defined as an individual or organisation (including an agency of a nation state) that conducts cyber espionage, cybercrime or cyber attack. Foreign state-sponsored actors may seek economic and other political or stra-

tegic security information for their national advantage, and they typically possess the most advanced and sophisticated tools and techniques, sometimes maintaining covert access to an organisation's systems for years at a time. They are often referred to as advanced persistent threats (APTs).

One of the largest continuous threats also comes from organised criminals, seeking financial gain through fraud and extortion, as well as issue-motivated groups and terrorist organisations.

### **Why you should be concerned about cyber espionage**

If your organisation is a multinational corporation, but also even if it is not, you should not discount the possibility of cyber espionage. Because of Australia's resource wealth and regional influence, as well as its broad range of commercial interests, expertise in many fields of scientific research, manufacturing and technology, and interconnected partnerships and alliances, it is an attractive target for this type of activity. According to the ACSC:

"The ACSC is aware that cyber espionage adversaries target industry networks in addition to government networks to acquire desired information. Cyber adversaries will target the weakest link; if the network security of their primary target is robust, they will move to secondary targeting of other networks that may hold the same information but are easier to compromise."

Cyber espionage obviously occurs with the intent to covertly collect valuable information and, as such, may not be initially a threat to an ICS, but rather the IT systems of your organisation — so, therefore, more of a threat to the financial viability and intellectual property of the organisation or other organisations and agencies the business may deal with. It therefore aims to not cause any noticeable harm, so as to go undetected. Such attacks can seriously hamper an organisation's reputation, profitability, competitiveness and business opportunities.



ONE MITIGATING FACTOR FOR ICT SYSTEMS SPECIFICALLY IS THAT THEY ARE GENERALLY CUSTOM-ARCHITECTED FOR THE PARTICULAR PROCESSING, MANUFACTURING OR CONTROL FUNCTIONS THEY PERFORM. IN 2014, CERT AUSTRALIA RESPONDED TO 11,073 CYBERSECURITY INCIDENTS, OF WHICH 153 INVOLVED SYSTEMS OF NATIONAL INTEREST AND GOVERNMENT.

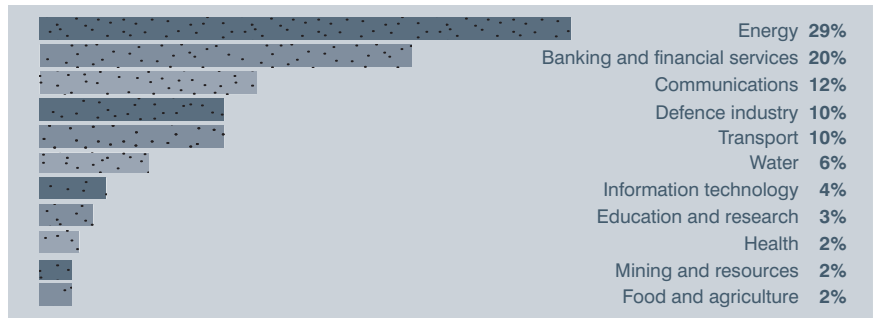

Figure 1: Incidents responded to by CERT Australia affecting systems of national interest and critical infrastructure in 2014. (Source: Australian Cyber Security Centre Threat Report 2015)

However, it is important to note (as we shall see later in this article) that the information gathered can also include information that will assist an overt cyber attack if desired at a later time — including attacks on an ICS. ACSC asserts that efforts by organisations to mitigate risk from cyber espionage will reduce the effectiveness and likelihood of ICS cyber attacks.

## Critical infrastructure organisations

The ACSC defines ‘systems of national interest’ as those systems that if compromised could result in significant impacts on Australia as a society. Critical infrastructure forms a subset of these systems and is typically that providing utility services (such as electricity, gas, water and wastewater) and transportation systems.

In 2014, CERT Australia responded to 11,073 cybersecurity incidents, of which 153 involved systems of national interest and government. The top five non-government sectors affected were energy, banking and finance, communications, defence industry and transport.

## Cyber attack

As a deliberate act of manipulating, degrading or destroying systems, cyber attacks are a serious concern. Overt destructive cyber attacks, particularly against systems of national interest, would be considered by the Australian Government to be an act of war.

The interconnection of ICS and IT systems makes these types of events more possible — although currently they are considered unlikely outside a period of increased tension or conflict with another

country. Hacktivists and terrorists may still pose a threat in this area, but are generally considered to not have the advanced skills and technologies of a nation state. Obviously this threat may still be a risk if your organisation’s defences are weak enough.

One mitigating factor for ICT systems specifically is that they are generally custom-architected for the particular processing, manufacturing or control functions they perform — as opposed to business IT systems that incorporate commonly known technology and processes. This generally makes control systems initially more difficult to manipulate or damage without first gathering considerable specific architectural and process knowledge. This is why protection from covert cyber espionage is as important as direct protection of control systems — to limit or prevent the gathering of the information necessary to perform an ICS cyber attack.

## Partnerships and supply chains

In an interconnected industrial world, organisations are increasingly connecting with each other to improve efficiencies. These connections may be many and varied, but commonly manufacturing organisations will have direct connections with organisations in their supply chain — to take advantage of the enhanced supply chain efficiencies that result — and may also allow suppliers such as automation vendors to connect to their automation systems for service and asset management services.

Due to the cost savings as compared with closed network links, the internet is the primary method of connection and may include the use of various technologies

including VPN links and cloud services. But, as stated above, a network is only as secure as its weakest link.

Cloud services are a case in point. As a cost-effective method of data sharing between sites, or between business partners and equipment vendors, they can introduce greatly enhanced efficiencies and cost savings. They also offer improvements in some aspects of data security at a lower cost. However, they also introduce their own risks. The ACSC reports the case of a company that in June 2014 was put out of business when a cyber adversary used the company’s legitimate login credentials to delete company data from a cloud service.

Some points the ACSC recommends be considered in relation to cloud services are:

- where the data may reside (offshore versus onshore) and whether the data is subject to foreign government data access laws;
- storing data in multiple locations and allowing more people to access it opens more opportunity for compromise;
- multitenancy cloud computing increases the likelihood of compromise, and proof-of-concept exploits that circumvent virtualisation have been developed.

## IT versus ICS cybersecurity

While some aspects of control systems today use similar or the same technology as IT systems (such as computers running Microsoft Windows operating systems), there are significant differences in relation to risk profile, as summarised in Table 1.

“Industrial Control Systems are not designed to ensure resilience against concerted attacks that intend to place components in

Attribute	IT	ICS
Confidentiality (privacy)	High	Low
Message integrity	Low-medium	Very high
System Availability	Low-medium	Very high
Authentication	Medium-high	High
Non-repudiation (Proof of the integrity and origin of data)	High	Low-medium
Time criticality	Days tolerated	Critical
System downtime	Tolerated	Not acceptable
Security Skills/Awareness	Usually good	Usually poor
System life cycle	3-5 years	15-25 years
Interoperability	Not critical	Critical
Computing resources	"Unlimited"	Very limited with older processors
Software changes	Frequent	Rare
Worst case impacts	Frequent loss of data	Equipment destruction, inquiries

Table 1: Comparing IT and ICS security risk factors (Source: ISA<sup>2</sup>)

dangerous operating states. This is expected to be a growing area of cyber-attack and engineering research."

Cyber attacks on IT systems usually focus on general-purpose operating systems and application software, exploiting inherent vulnerabilities via buffer overflows, zero-day vulnerabilities and cross-site scripting, and generally aim to capture valuable information or deny service. ICS attacks can be built on these methods but instead take aim at physical processes, exploiting legitimate design features. Another way to put it is that while IT cyber threats are based on unknown, or unmitigated flaws, ICS threats use persistent design vulnerabilities (PDVs), inherent in the design of the system as part of its function. The ISA refers to these not as "zero-day vulnerabilities" but as "infinite day vulnerabilities".

### Developing cybersecurity expertise

It is generally accepted that there is a significant knowledge and experience gap between the IT and OT sections of an industrial organisation. IT departments often have (or *should* have) more cybersecurity expertise, but the staff tend not to have engineering expertise. Operational staff, on the other hand, have engineering expertise but little or no security training and understanding. Bridging this gap is critical as IT and OT systems become more connected and, as a result of this divide, the role of ICS cybersecurity expert is emerging.

"In the IT environment, technology is available to monitor and identify cyber attacks, although there have been many cases where IT cyber compromised systems

have gone unseen for months. With critical infrastructure, it is very different. When an event occurs in critical infrastructure such as an electric blackout or a pipe break, the results are immediate and the impact can't be hidden. Without the perspective of an Industrial Control Systems cybersecurity expert, it can be difficult to determine if a cyber breach is the cause of a failure incident."<sup>2</sup>

ICS cybersecurity experts should be employed or trained to provide a similar function to that of an IT security expert, with the same understanding of security threat, risk and mitigation — only with an understanding of the physical automation process, the unique features of the ICS domain and industrial standards and processes. Such staff are needed to help bridge the 'culture gaps' that exist between IT and OT that can exacerbate the threats to the ICS and make it difficult to secure them.

### The intrusion kill chain

In defending any system against cyber attack, it is important to understand in a general sense the process an adversary may take to achieve their goal. The term 'kill chain' derives from military terminology. According to a paper presented at the 6th International Conference on Information Warfare and Security (Hutchins et al 2010)<sup>3</sup>:

"A kill chain is a systematic process to target and engage an adversary to create desired effects. US military targeting doctrine defines the steps of this process as find, fix, track, target, engage, assess (F2T2EA): find adversary targets suitable for engagement; fix their location; track and observe; target with suitable weapon

or asset to create desired effects; engage adversary; assess effects..."

The reason it is called a chain is because it is an end-to-end process — a failure at any point in the chain interrupts the process. The authors proposed a six-step kill chain model specifically for explaining the methodology for cyber intrusions, defined as reconnaissance, weaponisation, delivery, exploitation, installation, command and control (C2), and actions on objectives.

### In Part 2

The concept of a kill chain is important in understanding the approach of a sophisticated external cyber attack adversary. It also helps to understand the challenges faced by such an adversary should they want to perform malicious actions on an industrial control system — it is certainly no simple task. In Part 2 of this article, the concepts around the kill chain and how it pertains to an industrial control system cyber attack will be described in more detail.

#### References:

1. Australian Cyber Security Centre 2015, *Australian Cyber Security Centre Threat Report 2015*.
2. Weiss J 2016, *What Executives Need to Know About Industrial Control Systems Cybersecurity*, International Society of Automation.
3. Hutchins EM, Cloppert MJ & Amin RH 2010, *Intelligence-Driven Computer Network Defense Informed by Analysis of Adversary Campaigns and Intrusion Kill Chains*, Proc 6th Int'l Conf Information Warfare and Security (ICIW 11), Academic Conferences and Publishing Ltd 2011, pp 113-125.

## IOT GATEWAYS

AAEON has released the AIOT-QA, AIOT-QG and AIOT-QM IoT gateways. Running on the Intel Quark X1000 Series SoCs, the IoT-specific gateways are created and built to enable IoT applications both indoors and outdoors. Along with the low-power consuming chips, the devices are equipped with the Wind River Intelligent Platform, Linux support, McAfee Embedded Control security technology and Bluetooth/Wi-Fi/3G connectivity.

The AIOT-QA and AIOT-QG are built for indoor use, with the former attuned for industrial automation with a DIN-rail mountable design while the latter towards general-purpose applications. Both devices carry I/Os such as ADCs and digital I/Os that are beneficial for allowing the system to understand parameters such as temperature, humidity, luminance, water level, etc, for autonomous monitoring and control. The AIOT-QM additionally offers an IP67 design and a wide operating temperature range of -20°C to 70°C. All of its onboard I/Os, such as LAN, USB, COM, ADC and digital I/O, are specially designed with M12 connectors to discourage the intrusion of solids and liquids and reinforce protection against them.

**Glyn Ltd**

[www.glyn.com.au](http://www.glyn.com.au)



## CYBER THREAT DETECTION AND PREVENTION

Aiming to provide a next-generation security platform with industrial process control expertise, Honeywell Process Solutions (HPS) and Palo Alto Networks are collaborating to boost the cybersecurity capabilities of industrial control systems.

Honeywell's Industrial Cyber Security business is now offering the Palo Alto Networks Next-Generation Security Platform to industrial customers. The collaboration enables customers to better prevent cyber attacks against their process control networks and operational technology environments in order to protect their assets and maximise production uptime and safety.

The joint solution is designed to offer process network traffic monitoring and advanced threat prevention across the automation environment. It combines Palo Alto Networks' integrated security platform with Honeywell's process control domain expertise to provide a cybersecurity solution tailored for industrial customers.

The collaboration with Palo Alto Networks expands Honeywell's ability to provide proactive intrusion prevention, resulting in more robust protection for industrial customers.

Connecting vital infrastructure to the IIoT introduces the potential for great benefit, but also associated cyber risks. The collaboration between Honeywell and Palo Alto Networks is designed to meet the needs of industrial organisations and provide them with advanced threat detection and prevention capabilities.

The collaboration with Palo Alto Networks expands Honeywell's ability to provide proactive intrusion prevention, resulting in more robust protection for industrial customers.

**Honeywell Process Solutions**

[www.honeywellprocess.com](http://www.honeywellprocess.com)



## QUALITY CONTROL CAMERAS

The Jenoptik PROGRES GRYPHAX microscopy cameras are suitable for use in industry for quality control and controlling manufacturing processes as they are equipped with sensitive CMOS sensors for fast live images. Image capture software is included with a convenient graphical user interface and a modern USB 3.0 interface.

The microscope cameras offer a particularly large sensor format for microscopy. Short exposure times and high image refresh rates make the system quick and convenient to use. Even moving objects can be analysed with minimal effort.

The cameras reproduce colours with fine gradations and precise representation of the smallest detail.

Three models are available and include the GRYPHAX SUBRA, a Full HD colour camera offering a larger sensor format than other CMOS cameras, which can deliver Full HD recording of live images at video. The GRYPHAX NAOS is a 20 MP colour camera using a back-illuminated 25 mm CMOS sensor, while the GRYPHAX ARKTUR is an 8 MP colour camera using a back-illuminated 17 mm CMOS sensor.



**SciTech Pty Ltd**

[www.scitech.com.au](http://www.scitech.com.au)





# Engineered Control Valves, Regulators, Relief Valves and Process Instrumentation

**POWERFLO**  
SOLUTIONS



SVI-II-AP-35002



SVI-II-AP-21000



SVI-II-ESD



SVI-II-AP

## Masoneilan SVI II AP Digital Valve Positioner

- Field-proven non-contact position sensor or remote-mount positioner feedback
- Field upgradable options and firmware
- Explosion proof external LCD & pushbuttons
- Standard or high flow capacities eliminating or reducing the need of additional accessories (Booster, Quick exhaust...)
- Two (2) configurable and built-in isolated solid-state switches
- Industrial Aluminium or 316 Stainless Steel housing
- IEC Certified EEX 'd' & 'ia' enclosure
- Universal design for all types of linear and rotary Valve applications!!

## Masoneilan SVI II ESD Controller

- The first SIL 3 Smart ESD device that is LIVE during and after a shutdown
- Analog safety demand (ASD) or discrete demand (DSD) and 4-wire analog setpoint with DSD (A/DSD) outputs
- ESD health monitoring and PST Auto-Archiving
- Embedded local control panel & explosion proof buttons for:
  - Valve configurations & calibration
  - Local PST
  - PST, Safety trip and device data
  - Position feedback
- 70 + ESD warnings
- No Solenoid Required!!

Quality Control Solutions  
Advanced Digital Technology  
Global Customer Service

1300 658 701  
sales@powerflo.com.au  
www.powerflo.com.au



**Masoneilan**

# HOT PRODUCTS

ON [WWW.PROCESSONLINE.COM.AU](http://WWW.PROCESSONLINE.COM.AU) THIS MONTH

## SCANNING LINE SENSOR

The Ax20 scanning array sensor has a high-resolution line array with which a wide variety of objects can be detected with a repeat accuracy of up to 35  $\mu\text{m}$ .

**SICK Pty Ltd**

<http://bit.ly/1MiONG7>



## IS INTERFACES

The IMX12 interface series is an intrinsically safe line of devices that offers maximum signal density within a 12.5 mm housing.

**Turck Australia Pty Ltd**

<http://bit.ly/1RZ6sPu>

## MODULAR IPC PLATFORM

The MIC-7500 is a compact modular inter-process communication (IPC) platform with a fanless, ruggedised design.

**Advantech Australia Pty Ltd**

<http://bit.ly/1pv9Smf>



## NON-INTRUSIVE TEMPERATURE MEASUREMENT

Rosemount X-well Technology is a surface-sensing temperature measurement solution that eliminates the need for thermowell process penetration.

**Emerson Process Management Aust P/L**

<http://bit.ly/1Uezam0>



# CYBER SECURITY: A PERFECT STORM

As companies and industries increasingly rely on technology, security risks become greater. With growing numbers of Windows machines and increased scarcity of skilled technical resources, a “perfect storm” of cyber threats in production facilities is looming.

## THE FORECAST

Crucial utility networks face constant assault, and attacks are increasing.

\$114 BILLION



The annual financial cost of cybercrime globally.

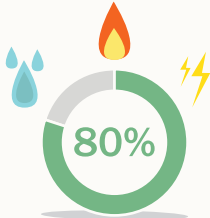

Water, gas, and energy firms around the world that reported hackers had compromised their security systems in the past year.



The increase in cyber attacks on critical utilities systems since 2009.

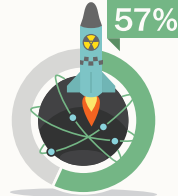

Global experts who believe that an arms race is taking place in cyberspace.



The cost per day of downtime from major attacks.



Industry executives who report frequently (at least monthly) finding malware designed to sabotage their system.

## 10 OUT OF 10 FACILITIES

are at risk due to lack of a robust, supported security maintenance program.

- ◆ Vulnerabilities/issues identified per asset
- ◆ High severity issues across fleet

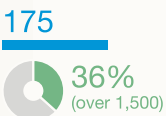

CHEMICAL

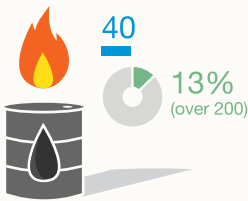

OIL AND GAS

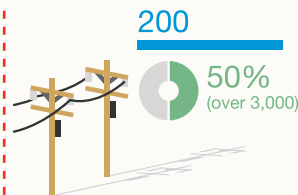

POWER GENERATION

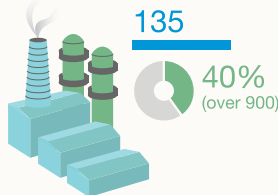

REFINING

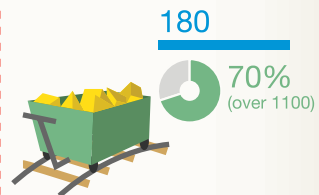

MINING, MINERALS & METALS

## WEATHERING THE STORM

Honeywell helps clients save tens of millions of dollars in downtime and avoid regulatory fines.

**3X**  
Amount of vulnerabilities traditionally identified by Honeywell to AV vendors annually, compared to the next biggest contributor.

**1500**  
Plant-specific, locally-located resources to help provide scalable, cost-effective solutions and support.

**15**  
Years Honeywell has been providing security solutions globally.

**60+**  
Number of different types of control systems secured.



## Solar plants maximise availability with Westermo industrial networks

La Florida and La Dehesa are both concentrating solar power (CSP) plants, located in south-western Spain and owned and operated by Renovables SAMCA. The plants are identical in size, construction and function. Each has a capacity of 49.9 MWe and supplies electricity for more than 45,000 homes. Such plants today make extensive use of redundant industrial ethernet technology for data communications between the various parts of the plant.

A CSP plant uses large mirrors to capture the sun's rays and focus the beam on a pipe containing oil. The heated oil is then pumped to the power plant, where the heat is converted into steam to drive a turbine. Each plant has more than 225,000 mirrors, grouped in 672 solar collectors which are continually adjusted via a control unit to follow the sun's path to maximise efficiency. Should data communications between the collectors and the control room stop, the collectors are automatically set to safe mode, which means they stop transferring energy. It is therefore essential to have a reliable data network.

For a solar power plant to be profitable, it must produce at maximum capacity at all times. All parts of the plant must work as planned and there must be backup systems should unexpected problems arise. Helping to meet this requirement, Westermo Industrial Data Communications was commissioned to create a highly reliable data communications network, which included 290 industrial ethernet switches, to maximise systems for availability at both the La Florida and La Dehesa thermal solar power plants.

"Plant availability is essential. Any interruptions to the communications affect our ability to generate power," explained Renovables SAMCA's César Labarga, electrical engineer and project manager for solar field control system, who was responsible for implementing the network at both plants. "We therefore needed a very reliable data network to support the plant control systems, and this is what we were provided by Westermo."

Labarga put it simply: "We needed a reliable system that could guarantee full availability, even in the event of a network link failure."

In addition to the critical requirements of network reliability and availability, Renovables SAMCA also needed the network equipment to be installed very quickly. A number of suppliers and solutions were considered, but as Labarga explained: "Of all the companies we talked to, Westermo's proposition was the simplest and best solution. The network topology offered the greatest reliability and the support offered by Westermo gave us great confidence in the solution."

Westermo's network topology was designed around a central dual gigabit fibre optic ring using 25 Westermo RedFox managed industrial ethernet switches. Nine subrings consisting of 120 Westermo Lynx switches were added to reach out to the different parts of the plant. Each subring was configured to create a primary and a backup link to the central ring. All individual rings in the network run the Westermo FRNT ring protocol, which enables 20 ms reconfiguration of the network in the event of link (cable or switch) failure. Because La Florida and La Dehesa are identical, the same solution could be installed at each plant.

Renovables SAMCA wanted a very quick and smooth installation process. To support this, Westermo built, configured and tested the entire network in advance in its laboratory in Sweden. The two complete networks, including all of the 290 switches, were mounted on a huge 'network wall',



enabling the network to be fully configured and tested prior to installation at the two plants. Labarga and a colleague from Renovables SAMCA, along with two employees from Masermic, the company responsible for supplying and maintaining the control systems for the two solar fields, were invited to Westermo's facility in Sweden to receive a short training session on the equipment and to oversee the factory acceptance test (FAT). This enabled them to evaluate the solution and make sure it met their requirements. The network was put through thousands of tests, with errors simulated to enable the network configuration to be fully proved. The solution was extremely reliable and the recovery from any errors was extremely fast.

"Having Westermo configure all devices beforehand was essential to this project. We needed a solution that was both easy to install and very reliable. The fully preconfigured Westermo solution was thoroughly tested and worked perfectly," said Labarga.

The Westermo devices were carefully labelled before they were sent to the customer to help simplify the installation process. Each preconfigured switch was placed exactly where it would be installed prior to the process starting. The installation process was extremely efficient, with all 290 switches installed and both networks up and running in less than three hours.

Ray Lock, from the Westermo Network Applications team, who was on-site to assist in the installation process and also perform the site acceptance test (SAT), said: "This was a very well thought-out solution, right from the choice of products and network design through to the network testing and implementation."

When performing maintenance at the power plants, the normal procedure requires that parts of the communications network be shut down periodically. This continually tests the resilience of the network configuration, but since the equipment was successfully installed there have been no reported problems or serious incidents.

"Having installed the Westermo devices successfully, we are now very happy with how the network is performing. It is a really stable and reliable solution and the continued support from Westermo has ensured that we have had no problems," said Labarga.

**Westermo Teleindustri AB**  
www.westermo.com

**FPI-X™ Mag Meter**  
Advanced Flow Measurement



**FPI Mag®**

**The Ideal  
Mag Meter  
for Extreme Flow  
Conditions**

**Simple, Fast Installation:**

No cutting pipe or welding flanges

**± 0.5% Proven Accuracy**

- ✓ Multiple Pump Discharge
- ✓ Severe Swirl
- ✓ Single Pump Discharge
- ✓ Total Station Discharge

**Contact AMS Instrumentation  
& Calibration Pty Ltd today at  
03 9017 8225**

**or visit us online to learn more:  
[www.ams-ic.com.au](http://www.ams-ic.com.au)**



Unit 20, 51 Kalman Drive,  
Boronia, Vic, 3155, Australia  
[www.ams-ic.com.au](http://www.ams-ic.com.au)  
P: 03 9017 8225 | F 03 9729 9604



**WIRELESS ACCESS POINTS**

Belden has released the BAT450-F industrial wireless local area network (WLAN) access point range. The devices can be mounted anywhere, such as on masts or on walls, making them suitable for environments where space is limited.

The ruggedised design of the product withstands harsh industrial environments while maintaining the modular and compact size needed in many industrial network scenarios. The wireless access points are flexible, enabling network managers to use them as access clients or access points operating as routers or bridges. They also offer wireless wide area network (WWAN), WLAN and ethernet interfaces to fit individual network needs.

The access point's dual-band radio allows for simultaneous voice and data communications, for example. The low weight and small footprint suits industrial environments, such as power transmission and distribution, process automation and oil and gas, as the access points can be mounted in confined spaces on walls or masts and allow for communication across long distances.

As the successor to the BAT300-F range, the WLAN access points enable the integration of Industrial Internet of Things (IIoT) functionality and can be configured to specific application needs, network functions and country-specific protocols.

**Belden Australia Pty Ltd**  
[www.belden.com](http://www.belden.com)



**IS BARRIER**

The WIKA IS Barrier is suitable for installation in Zone 2 and is compatible with all corresponding transmitters from WIKA.

For use in hazardous areas, intrinsically safe transmitters require a barrier. It galvanically isolates the circuit between Ex and non-Ex areas. The model IS Barrier supplies sensors — depending whether it is a two- or four-wire system — via a powered or non-powered 0/4–20 mA input and also supports HART transmission.

The current output can be operated actively or passively.

The functional safety of the instrument is confirmed by the approval for SIL 2 applications.

In addition to the sensor and barrier, it includes the matching cables and a certificate containing the data for the prescribed verification of intrinsic safety.

**WIKA Australia**  
[www.wika.com.au](http://www.wika.com.au)



### **SINGLE-BEAM SAFETY SENSORS**

The Leuze 46C series single-beam safety sensor range has been upgraded, with improved functionality in the areas of optimised ambient light suppression and automatic sensitivity readjustment in the event of contamination

and reflections. These improvements result in less downtime. The series is suitable for use in conveyor systems, the wood processing industry and special-purpose machinery manufacturing.

With an operating temperature range from -40°C to +60°C and protection ratings of IP67 and IP69K, the sensors are made for harsh environmental conditions. Other equipment features include a teach button or adjustment screw for simple and fast configuration directly on the device, a potentiometer with a large adjustment range, a highly visible light spot and an improved status LED indicator behind the front screen with the 46C through-beam photoelectric sensors.

**Leuze electronic Pty Ltd**  
[www.leuze.com.au](http://www.leuze.com.au)

### **MANUFACTURING EXECUTION SYSTEM**

Emerson Process Management has enhanced the Syncade Suite manufacturing execution system (MES) to help life science manufacturers simplify the transfer of recipes and manufacturing information between project phases and system environments — from design through to validation and production. The updated functionality automates the transfer of product recipes, material master information and configuration settings, while also enabling users to archive the associated order execution information in a secure environment.

Time to market is critical in the life science industry. Implementing a product recipe typically requires time-consuming verification that the production system accurately reflects all the settings and configuration work implemented through the development and test process. With Syncade transfer and archive functionality, users achieve required accuracy and reduce rework by automating the transfer of information from the development environment, to the validation environment and to the production environment.

In addition, the Syncade MES enables users to efficiently manage the archiving of orders, materials and inventory data. Because archived information is stored in a database separate from the transactional database, users do not overload or slow down the database used for day-to-day operations. Current and past data can be searched and retrieved quickly.

**Emerson Process Management Aust P/L**  
[www.emersonprocess.com.au](http://www.emersonprocess.com.au)



### **SLOT-MOUNTING POSITION SENSOR**

The SICK MZT7 magnetic cylinder sensor enables quick, precise and contactless sensing of the piston's position in compact pneumatic cylinders. It is easy to mount and can be used in numerous applications.

The product can be mounted directly into all cylinders with standard T-slots. An extensive range of adapters is

available, which enables the sensor to be used with other cylinder types. The device is characterised by its simple mounting principle: insert the sensor into the slot and rotate the locking screw a quarter turn to fix it securely to the cylinder.

The magnetic cylinder sensor never loses its grip: when mounted directly in the T-slot, the universal housing design compensates for the various slot dimensions from a wide range of cylinder manufacturers.

The magnetic cylinder sensor is suitable for a multitude of applications and a wide range of cylinder types in assembly and handling machines, packaging machines and electronics production. It is so versatile that only one sensor variant is necessary. The sensor is also available as RZT7, with reed technology and a supply voltage of up to 230 V.

**SICK Pty Ltd**  
[www.sick.com.au](http://www.sick.com.au)



## PASvisu – New web-based visualisation software

- ▶ All of your automation at a glance
- ▶ Simple configuration and optimum visualisation
- ▶ Achieve a convenient, comprehensive overview of your plant, locally or via remote access
- ▶ Works on wide range of end devices as the system is platform independent (PC, iPads, smart phones etc.)
- ▶ Standardised look and feel thanks to project wide design templates

**PILZ**  
THE SPIRIT OF SAFETY

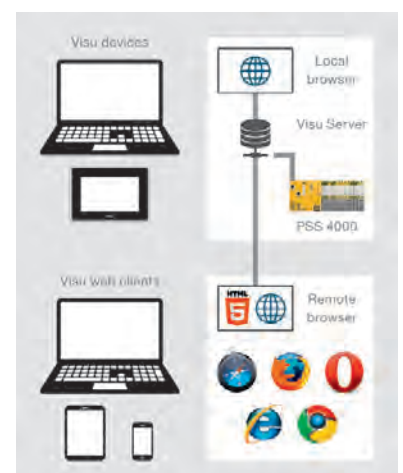

Melbourne • Sydney • Brisbane • Auckland

Ph: 1300 723 334 Ph: 03 9560 0621 Fax: 03 9574 9035

[www.pilz.com.au](http://www.pilz.com.au) [safety@pilz.com.au](mailto:safety@pilz.com.au)



### OVERLOAD RELAY

Schneider Electric has released the TeSys LR9D electronic thermal overload relay that is claimed to provide advanced, flexible and reliable protection for motors, improving both equipment life and cost savings.

The relay is suitable for use across a wide range of applications, including pumping, HVAC, hoisting, material working and packaging.

It features a selectable trip class (5, 10, 20, 30) for setting the desired level of protection, has a 5:1 adjustment range, fits a wide range of

applications from 0.1 to 110 A and is self-powered, eliminating the need for an external power supply.

By incorporating multiple functionalities in a single space-saving design, the TeSys LR9D relay simplifies control architectures as well as making it simple to select and stock motor protection devices.

**Schneider Electric Industry Business**

[www.schneider-electric.com](http://www.schneider-electric.com)



### CELLULAR ROUTER

The Robustel R3000 router is a ruggedised cellular router in a metal housing measuring 125 x 108 x 45 mm. It allows operation on global 4G and 3G networks with fallback to 3G/2G and allows data speeds up to 100 Mbps download and 50 Mbps upload. It has RCM certification for Australia and New Zealand.

The routers have dual SIM card holders to ensure cellular connectivity remains when continuity of service levels is important. Options include Wi-Fi and GPS/GLONASS communications. Modbus gateway is supported, which makes it easy to integrate into any industrial automation project. An SDK is also available for those who want to develop their own user application.

The router comes with up to four ethernet ports, allowing various WAN/LAN configurations including support for wireless WAN and wired WAN backup. It has RS232, RS485, digital I/O and one USB host serial port. A micro SD card port is available for data logging.

The router has a wide operating voltage range of 9–60 VDC and an operating temperature range of -40 to 85°C. Applications include smart transportation, wireless CCTV, ATM/vending kiosks and power generation/distribution equipment. The product supports RobustVPN and RobustLink.

**Glyn Ltd**

[www.glyn.com.au](http://www.glyn.com.au)



### ENERGY SELF-SUFFICIENT RTU

The Simatic RTU3030C RTU works fully independently with a power supply provided by batteries or a solar panel, enabling its flexible use in varied fields of application such as the water and wastewater industry.

The RTU's robust design enables it to be used under the toughest of ambient conditions (-40 to +70°C). An additional enclosure with a protection rating of IP68 allows reliable operation even under flood conditions. It can be operated using up to two high-powered industrial batteries or a rechargeable battery (combinable with a solar panel). Users also have the option of connecting a 12–24 VDC power source where this is available.

The RTU3030C can be operated in sleep, update, communication and service modes. The power requirement in the sleep mode is less than 2 mW, allowing operation over a period of several years. Connection to the control centre uses the integrated UMTS modem over the wireless network — with a secured OpenVPN connection or encrypted emails. Communication can be time or event controlled and also individually configured for each process value. Service mode is used for maintenance operations such as exchanging batteries without loss of data.

The Simatic RTU3030C can be linked to a Simatic PCS 7 control system or to Simatic WinCC using the TeleControl Server Basic software package. Direct connection to Simatic PCS 7 TeleControl or Simatic WinCC/TeleControl is also possible using the telecontrol protocols IEC 60870-5-104 and DNP3. In this way, support for wide-ranging telecontrol protocols enables flexible connection to any optional SCADA system.

**Siemens Ltd**

[www.siemens.com.au](http://www.siemens.com.au)



# ▶ Always a good solution



**OPTISYS CL 1100**  
Measuring system for free chlorine, chlorine dioxide and ozone with automatic sensor cleaning system for safe use and extended lifetime



**OPTISYS SLM 2100**  
Optical measuring system for sedimentation profile measurement and continuous tracking of sludge blanket



**OPTIBAR LC 1010**  
Submersible level probe with ceramic diaphragm 22 mm



**WATERFLUX 3070 IP68**  
Battery-powered water meter for large turndown ratios and small spaces with no inlets or outlets



**TIDALFLUX 2300 F**  
Flowmeter for partially filled pipelines, Ex Zone 1



**OPTIWAVE 5200**  
2-wire FMCW radar level transmitter for liquid applications



**OPTITEMP TRA/TCA-S12**  
Temperature assembly for screw-in

**KROHNE**

▶ measure the facts

## ▶ You're searching for an efficient measurement solution? No problem with KROHNE.

KROHNE has met the challenges of the water and wastewater industry with innovative measuring solutions.

KROHNE offers a whole spectrum of flow, level, temperature and pressure measurement as well as process analysis technology including complete solutions and the pertaining services.

We supply instrumentation for all stages of potable water production and transport, including water catchment, water treatment, storage, distribution and leakage control. In wastewater networks, KROHNE is known to provide measuring solutions for sewage water transport, mechanical pretreatment, biological treatment, as well as sludge and effluent monitoring.

Our additional services secure efficient planning, commissioning and maintenance of water and wastewater systems.

KROHNE – Water and wastewater is our world.

KROHNE Australia  
5 Phiney Place • Ingleburn NSW 2565 • Tel: 02 9426 1700



[www.krohne.com](http://www.krohne.com)

**CODE READER**

The Lector63x is a 2 MP image-based code reader developed in a compact but flexible design. The design of the optical concept supports the usage of a wide range of lenses, from simple, small S-mount lenses to high-quality C-mount lenses. For all compact lenses there is a set of integratable but exchangeable ring lights — each perfectly fit to cover the optimum viewing angle for the different lenses. These ring lights are easy to mount without cabling and are equipped with a convenient filter holder to make it easier to switch out the filters. The optics can be covered by hoods to meet the IP67 rating.

Function buttons, LEDs and an aiming laser enable quick installation. The user interface is intuitive, with a quick set-up function. It is designed to fit into SICK's 4Dpro concept, which helps ensure easy integration in surrounding networks and compatibility to other identification technologies from SICK.

The Lector63x image-based code reader is more compact than the Lector65x and more powerful than the Lector62x. The optical flexibility, in combination with leading decoder technology, ensures reliable reading performance for the application. The product can provide an advantage in a variety of applications, such as identification in manual parcel sorting or automated sorting systems in CEP and retail; serialisation and end-of-line aggregation for the food or pharmaceutical industries; long-range identification for traceability in the automotive industry; and high-resolution code reading in the electronics and solar markets.

**SICK Pty Ltd**  
[www.sick.com.au](http://www.sick.com.au)



**PACKET FORENSICS  
APPLIANCE**

NextComputing recently announced the CyberPro portable packet forensics appliance.

Within a mobile, lightweight test appliance, CyberPro offers a high-speed packet capture, indicators of compromise event alerting, BPF filter event triggering and a fully integrated analytics workflow with a collection of open source packet analysis software tools. Users can view IoC logging over a long PCAP forensic timeline and post-process PCAPS for packet analytics and visualisation.

CyberPro is designed for network performance monitoring, cyber forensics, compliance enforcement, lawful intercept and packet data analytics. It is a tool for today's field technicians, IT/InfoSec specialists and network engineers whose mission is to keep modern digital IP networks up and running and fully protected.

It features three options for lossless packet capture: 1–3 Gbps, 3–6 Gbps and 10 Gbps. Simultaneous PCAP search and RFC anomaly logging, along with active triggers (real-time, dynamic and user-defined) are supported, along with file download hash logging, as well as multiprotocol event/metadata logging. A unified web GUI helps to manage PCAPs or an entire cyber investigation.

**Metromatics Pty Ltd**  
[www.metromatics.com.au](http://www.metromatics.com.au)

**SIGNAL TOWER LIGHTS**

Pfannenberg's BR50 range of signal tower lights offer a flexible modular design with a sturdy housing for indoor and outdoor applications.

Up to five modules with six lens colours may be used on the signal tower, with any combination of continuous LED, blinking LED and flashing xenon elements. A sounder module can be added for an audible alarm up to 85 dB and an ASi bus module is available for simple integration into a network.

For safety-sensitive applications where a single failure is not an option, a monitored light module is available in red and yellow. The monitored modules have two separate LED circuits integrated within the module — so if one circuit were to fail, an alarm contact will activate and warn the operator while the second circuit continues operate.

The range has multiple mounting options available, starting from a simple base mount on a flat surface with 100, 250 and 400 mm tubing. Stand mounting options are also available. IP54 protection is standard and IP65 is available as an option to ensure harsh environmental elements are no threat.

**Control Logic Pty Ltd**  
[www.control-logic.com.au](http://www.control-logic.com.au)



Our last project came in behind schedule and over budget.  
The next project is even bigger.  
It's going to be a monster unless we do things differently.

# IT'S IMPOSSIBLE



**It's time for Project Certainty.** Emerson's transformational approach to capital project execution provides a fresh, new look at projects so that you meet your original budget and schedule targets. Using a combination of innovative products and services, Emerson provides a path to reduce complexity, eliminate cost, and accommodate late changes. Reset design, engineering, and project management to make your project more predictable and reliable.  
**Learn more at [www.emersonprocess.com/projectcertainty](http://www.emersonprocess.com/projectcertainty)**



The Emerson logo is a trademark and service mark of Emerson Electric Co. © 2016 Emerson Electric Co.

**EMERSON. CONSIDER IT SOLVED.™**



*Simon Lillie, Product Specialist, Field Instruments, Yokogawa Australia*

There have been many concerns expressed over the security and reliability of industrial wireless technologies since their inception, but these concerns have been overplayed.

**W**ireless is a hot topic and is being discussed in forums, print and day-to-day conversations around the globe. In each of these discussions the security of a wireless network is the main topic of concern. This is unfortunate and almost completely unfounded, as the correct wireless system is ideally suited to many industrial situations, especially in areas where hardwired connections are expensive or impractical due to distance, access or physical hazards.

Most of us have come into contact with industrial wireless via our use of wireless networks for home and office applications. We have seen that security on these types of networks was initially poor or lacking. Due to these past experiences, everyone is now wary of wireless communications, especially when we start looking at employing it in industrial process and production plants.

In reality, industrial wireless systems are purpose-built to address these security issues in the same way internet banking has been securely deployed around the world. However, of the two common standards, ISA100.11a and WirelessHART, one is clearly easier to secure than the other, due to its additional in-built safety protocols (more below).

Robust security features are built into the standards and the devices in each of the systems and these cannot be disabled. The two standards have been designed to ensure data and system integrity as well as ensuring they still remain easy to use and employ.

### Encryption

The protection of data is one of the main features of the industrial wireless standards. Data security is implemented from the device to gateway utilising Advanced Encryption Standard (AES) 128-bit encryption. Wireless messages are enciphered such that only the final destination can decipher and utilise the data. AES is based on a design principle known as a substitution-permutation network, and is extremely secure. All known attacks on AES are computationally infeasible, which is why it is used in applications such as internet banking. This is further demonstrated by the fact that the US government previously announced that the design and strength of all key lengths of the AES algorithm are sufficient to protect classified information up to the 'secret' level. For AES 128-bit, the key can be recovered with a computational complexity of  $2^{126}$ . To further ensure security on an industrial wireless network, a security join key is also employed. The join key serves as authentication to the network security manager for the device to be allowed onto the network. If a device does not broadcast the correct join key it is not permitted to enter the wireless network or to send any data on it, effectively preventing rogue devices from compromising the network.

### Potential security risk

For a WirelessHART network, a HART communicator is employed to manually enter the join key into each field device. A common



© Stock.Adober.com/au/hanssem

join key (like a physical 'master key') can be used across multiple devices making set-up easy, but this also means that security could potentially be compromised. ISA100.11a wireless devices take join keys one step further. For these devices infrared (IR) communication is used to ensure a secure and short-range connection to a PC. Authorised software on the PC then provides a fully encrypted join key which is unique to each individual field device and cannot be copied or compromised. That way, only a properly authenticated device is permitted to join the network. This is an important safeguard for industrial wireless users.

### Interference

Apart from data integrity, the wireless network must also be secure against interference — another key concern among those yet to make the step to industrial wireless. The ISA100.11a and WirelessHART standards employ a 2.4 GHz frequency for data transmission. This frequency is within the Industrial Scientific and Medical (ISM) band, which is open worldwide and hence is used by many other wireless technologies as well, such as Wi-Fi and Bluetooth. It is essential that the industrial wireless standards can co-exist with these other technologies and hence they have a number of in-built features to ensure this is successful. There are several technologies employed in the ISA100.11a and WirelessHART standards to minimise interference, which include



ROBUST SECURITY FEATURES ARE BUILT INTO THE STANDARDS AND THE DEVICES IN EACH OF THE SYSTEMS AND THESE CANNOT BE DISABLED.

frequency and channel hopping, channel blacklisting, DSSS and low-duty cycle operation.

#### **Frequency/channel hopping**

The 2.4 GHz frequency is divided into 16 non-overlapping channels. Devices employ a channel hopping sequence to enable them to reduce the chances of interference with other networks. The ISA100.11a or WirelessHART network manager allocates the frequencies and hopping sequence to be employed automatically without any user intervention being required.

#### **Channel blacklisting**

The wireless network can be manually configured to avoid one or more frequency channels. If there are specific frequencies that are highly utilised by other networks, the ISA100.11a or WirelessHART network can avoid operating on these channels and hence reduce the potential for interference.

#### **Direct Sequence Spread Spectrum (DSSS)**

This technology allows the wireless transmission to be spread over the entire frequency channel. Devices with the correct decoding information receive the data while for other devices it appears as noise and is disregarded.

#### **Low-duty cycle operation**

Employing time division multiple access (TDMA) means the network can be divided into configurable-length timeslots, typically between 10 and 14 ms. Wireless transmissions then occur at precise, predetermined times and hence limit the network loading and chances of collisions.

### Conclusion

The industrial wireless standards, ISA100.11a and WirelessHART, have been designed with security in mind. By employing AES-128 bit encryption and secure join keys, data security is ensured. Numerous methods to minimise interference are also built into the standards to ensure they can co-exist with other technologies. With all these features we can now see that the industrial wireless standards are robust and secure enough to provide a valid solution for any industrial process application.

**Yokogawa Australia Pty Ltd**  
[www.yokogawa.com.au](http://www.yokogawa.com.au)



**COMPACT SAMPLING SYSTEM**

The ES20 compact sampling system from Michell Instruments now has the option of an Easidew PRO XP dewpoint transmitter. This makes the system suitable for a range of moisture measurement applications in hazardous areas where explosion-proof certification is needed, in addition to the existing intrinsically safe options.

The ES20 system was designed to offer several standard configurations suited to typical industrial and gas process applications, such as monitoring moisture in compressed air or natural gas. These standard configurations enable short lead times and fast delivery of orders.

Sample conditioning is vital when monitoring moisture levels in gas, not only to ensure that the pressure and temperature of the sample gas is consistent, but also to prolong the life of the sensor by removing contaminants such as dust or molecules of oil carried in the gas stream. The ES20 compact sampling system offers a choice of particulate or coalescing filters with a maximum pressure of 20 barg. Three mounting options are also offered to suit various indoor or outdoor locations: the system can be either mounted on a base plate, within a GRP enclosure or with a stainless steel enclosure, to provide IP66/NEMA 4X protection.

The dewpoint transmitters provide accuracy of  $\pm 2^{\circ}\text{Cdp}$ , with a wide measurement capability of  $-100$  to  $+20^{\circ}\text{C}$  dewpoint, and are available with Michell's sensor exchange program, in which users are able to order a freshly calibrated sensor to fit in their system, replace their old sensor and return it to Michell.

The dewpoint transmitters provide accuracy of  $\pm 2^{\circ}\text{Cdp}$ , with a wide measurement capability of  $-100$  to  $+20^{\circ}\text{C}$  dewpoint, and are available with Michell's sensor exchange program, in which users are able to order a freshly calibrated sensor to fit in their system, replace their old sensor and return it to Michell.

**AMS Instrumentation & Calibration Pty Ltd**

[www.ams-ic.com.au](http://www.ams-ic.com.au)



**CAPACITIVE SENSORS**

Turck is expanding its range of capacitive sensors, now offering 18 and 30 mm capacitive barrel sensors with teachable capabilities. The sensors come in two variants — teach-by-wire or teach-by-button.

The teach-by-button variant can be taught by a single press of a button, saving installation and configuration time. Both present and absent media can be taught for a higher sensitivity teach. The variant without a push-button can be taught either by a teach adapter or teach-by-wire (pin 5), which allows for a tamper-resistant installation. Each variant is available in either PNP or NPN.

The 18 mm version offers a 5 mm sensing range when flush mounted and a 7.5 mm range when not flush mounted. The 30 mm version offers a 10 mm sensing range when flush mounted, with a sensing range of 15 mm when not flush mounted. The expanded range can be switched between NC and NO, and provides optical programming feedback through LEDs.

**Turck Australia Pty Ltd**

[www.turck.com.au](http://www.turck.com.au)

HVAC  
Dynapar Veeder-Root Eagle Signal Line Seiki Keyence Maple Greystone Novotechnik TWK AECO  
PLCS  
Time Count Rate Flow  
Encoders HMIs Controllers  
ph: 1 300 553 500 enhance your sensors VEEDERLINE [www.veederline.com.au](http://www.veederline.com.au)

**Weighing Electronics**

- Panel, rail or surface mount displays and transmitters
- Analogue outputs, Serial and Modbus communications
- Portable battery powered units with data logging and USB

**INSTROTECH**  
INSTRUMENTATION AND PROCESS CONTROL  
[www.instrotech.com.au](http://www.instrotech.com.au)  
telephone 1800 999 063  
[sales@instrotech.com.au](mailto:sales@instrotech.com.au)

STAHL

# avoid a catastrophe

the largest range of IECEx equipment



Control Logic presents **R.STAHL**, the world's leading supplier of IECEx certified equipment for the hazardous area electrical industry in Australia.

From basic motor control and isolation to lighting, sight and sound products, terminal enclosures and junction boxes, we have an unbeatable range of IECEx equipment to avoid a catastrophe.

With a large stock holding in Australia, a fully accredited workshop and a specialist team that understand the Ex market, ensure your safety now and into the future.



**hazardous area equipment**  
**extremely high quality**  
**zones 1, 2 and 21, 22 covered**  
**australian based assembly**

**STAHL. AUSTRALIA PROOF.**

for more information call 1800 557 705 or email [sales@control-logic.com.au](mailto:sales@control-logic.com.au)  
[www.control-logic.com.au](http://www.control-logic.com.au)

  
**control logic**

industrial.  
electrical.  
automation.

**CELLULAR NETWORK CONTROLLERS**

The ZigSense model ZS3G-SMS-P2P is a cable replacer matched pair cellular network controller designed to transfer digital on/off commands between two remote sites where no line of sight is available and the distance between the two sites is extremely far.

Starting or stopping a remote pump and receiving feedback or alarms about the pump's condition can be done by sending an SMS command straight from a mobile phone to the remote pump. Alternatively, a local PLC can toggle a start/stop output which is wired to the local SMS controller. The local SMS controller then sends a text message to the remote SMS controller (wired to the remote pump), which in turn opens or closes a relay contact associated with the pump.

At the same time, alarm conditions existing at the remote pump site will send a text message back to the local PLC, which will be recognised by the PLC logic and at the same time advise the operators of the alarm condition by issuing SMS messages to their mobile phones.

The two ZS3G-SMS-2 I/O controllers use two different SIM card numbers to communicate over existing 3G/4G cellular networks. Each controller supports two digital inputs (24 VDC max) and two 'dry' digital outputs (125 VAC, 3A).

The controller can be powered by a 12-24 VDC supply. Set-up and programming of the ZS3G-SMS controller is achieved by issuing English-language text commands sent to the controller from a standard mobile phone. There is no need for programming software.

**Conlab Pty Ltd**  
[www.conlab.com.au](http://www.conlab.com.au)

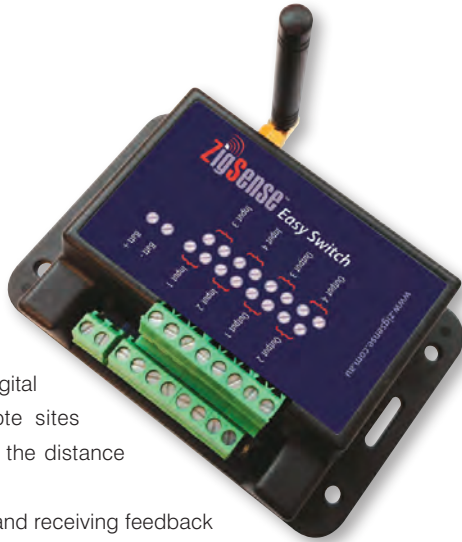

**VIDEO CAMERA**

The Olympus i-SPEED LT video camera gives valuable insight into production lines and any problems they might have. If an area intermittently breaks down, users can set the camera up at that area to find out why, so it can be fixed. It is available to rent from TechRentals.

This simple point-and-shoot camera is portable and easy to use with images provided in colour instantly for review and analysis, and is also provided with a stand and F- and C-mount lenses for zoom versatility.

Sensor resolution is 800 x 600, and the camera has a 2000 fps recording capability.

Onboard editing is possible, as well as optional battery operation.

**TechRentals**  
[www.techrentals.com.au](http://www.techrentals.com.au)





**THE ACCURACY YOU NEED,  
THE DEPENDABILITY YOU WANT**

---





TO LEARN MORE  
**(+61) (0) 2 4272 2055**  
[dwyer-inst.com.au](http://dwyer-inst.com.au)



**Pressure Transmitters**



**Flow Switches/  
Transmitters**



**Level Transmitters**





**IO-LINK SENSOR/ACTUATOR HUB**

IO-Link actuator/sensor hubs from Balluff feature eight ports for 16 I/Os. They allow, for example, signals from up to 16 switching sensors to be collected from a distance of up to 20 m so that they can be made available to the machine controller via IO-Link and an IO-Link master using a simple 3-conductor cable. Versions are also available with an expansion port.

Slot 7 can be reconfigured as an expansion port by means of a simple parameter entry, so that a complete valve plug or an additional sensor hub can be connected to it. For the user this means a significant gain in flexibility and efficiency. Now it is possible not only to cost-effectively process additional I/Os, but also expand the range to a circle of another 20 m. Due to plug-and-play and the use of unshielded standard cables, the system can be started up quickly.

**Balluff Pty Ltd**  
[www.balluff.com.au](http://www.balluff.com.au)

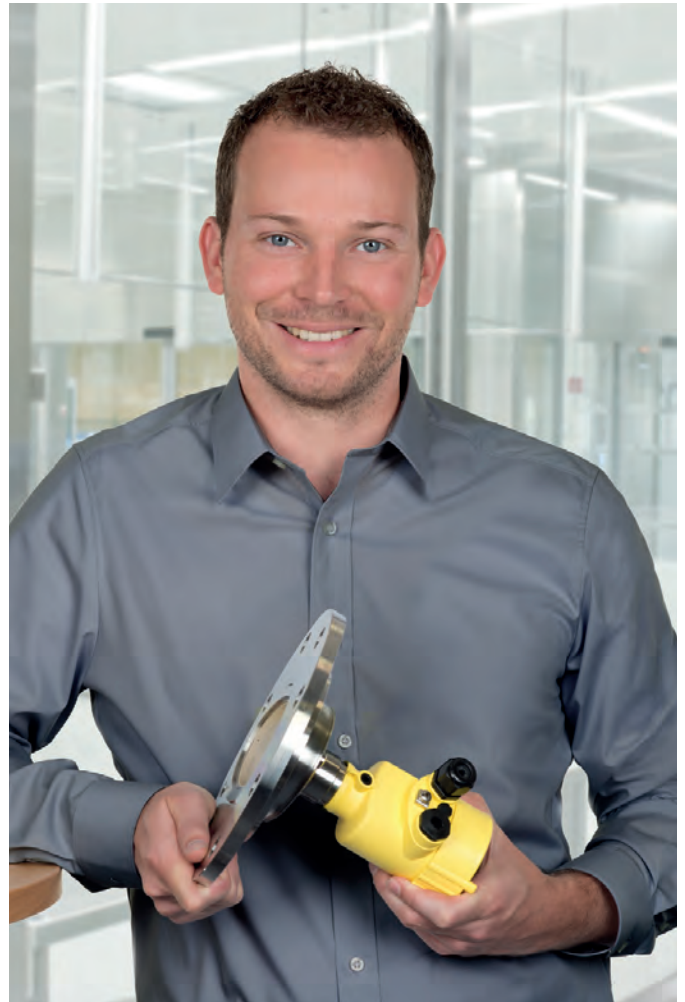

The radar sensor for bulk solids

**Level measurement with bulk solids radar, making the impossible possible:**

The most modern radar level technology and a frequency range of 79 GHz has made the new VEGAPULS 69 radar the sensor of choice for bulk solids industries. This sensor is capable of measuring poorly reflecting bulk solids over long ranges, in narrow, or even segmented vessels.

- Measuring range: up to 120 m
- Very good focusing: simplifies the setup
- Encapsulated antennas: reliable results even with buildup
- One device for all bulk solids

[www.vega.com/vegapuls69](http://www.vega.com/vegapuls69)



Looking Forward

**LIGHT CURTAIN**

The CSL 710 is a programmable switching light curtain with a range up to 8 m, selectable resolutions and four configurable inputs and outputs. The product has an integrated display and can easily be aligned and taught to a wide range of object heights up to nearly 3 m. With its high resolution, short cycle time of 30  $\mu$ s per beam and fast response time of 1.36 ms, it is well suited for the detection of small objects.

The curtain has an operating temperature range of -30°C to +60°C and an IP65 rating, adding to its functionality. Due to the M12 connector, the electrical installation can be performed quickly. Various device and mounting options enable adaptability to the installation conditions. A wide choice of range and height options (up to 3 m) is available.

**Leuze electronic Pty Ltd**  
[www.leuze.com.au](http://www.leuze.com.au)





**CABLE GLANDS**

Treotham has recently partnered up with Pflitsch, a German manufacturer of cable glands and accessories. Pflitsch cable glands provide reliable seals with the durability necessary for industrial environments. Effective strain relief ensures that the cables cannot slip out or be pulled out of the connector.

The cable glands are suitable for a number of industries including the railway, electrical, food, chemical and pharmaceutical industries, energy production and distribution, renewable energies (wind and solar), machinery and equipment, as well as automation and robotics.

The Pflitsch glands achieve high ingress protection ratings of IP68 and IP69K, fulfil international standards such as VDE, UL, CSA and GOST, and meet the requirements of EMC and ATEX standards.

In addition to cable glands, Treotham also offers Pflitsch cable trays, accessories, tools and machine tools.

**Treotham Automation Pty Ltd**

[www.treotham.com.au](http://www.treotham.com.au)

**BIDIRECTIONAL KNIFE GATE VALVE**

Pentair Valves & Controls has launched the Keystone OS1700, a bidirectional, zero-leakage ASME Class 150 rated knife gate valve designed to provide high performance at high pressures for applications in sectors from mining to pulp and paper.

The full-round port and advanced seat design, which places the elastomer seat outside the flow path, minimises turbulence to extend the life of the valve and protect downstream pipework and equipment. It is suitable for inline or dead-end service up to full rated pressure. Built to MSS-SP135 short pattern specifications, it is said to require lower maintenance and offer improved reliability.

The product is designed for challenging applications, such as high-pressure slurry and oil sands applications, but it is also useful for protecting against process pressure spikes that could damage an ordinary knife gate valve and any associated equipment. The MSS-SP135 short pattern face to face also matches MSS-SP81 dimensions to make upgrading an existing knife gate installation simple.

The valve is available in sizes from NPS 2 to 48 (DN 50 to 1200). The precision-moulded elastomer seat — which is available in EPDM, HNBR or GUM — enables the valve to operate at up to 200°C.

**Pentair Valves & Controls**

[pentair.com/valves/](http://pentair.com/valves/)



**2016 PROFIBUS & PROFINET Global Forum | Automation Innovation Summit**  
*Innovation: It's not just for Start Ups and IT Companies | Sydney 25 May 2016*

**FORWARD THINKING**

Join us at the 2016 PROFIBUS & PROFINET Global Forum and Automation Innovation Summit for an exchange of ideas.

Learn about how companies both local and global are benefiting from innovation and

automation. Hear from a range of technical experts, industry leaders and government leaders as they present a practical plan of action to turbo-boost the next decade of innovation and growth in Australia.

For further information and Ticket Sales contact Profibus Australia.

Tickets: [www.profibusaustralia.com.au](http://www.profibusaustralia.com.au) or call 02 9555 7899.





**STAINLESS STEEL FACED SENSORS**

Turck has announced four 2-wire, DC stainless steel faced sensors with an extended sensing range.

The Bi2-EG08F-AG6X, Bi3-EG12F-AG6X, Bi7-EG18F-AG6X and Bi12-EG30F-AG6X stainless steel-faced sensors are suitable for use as substitutes for traditional plastic-faced sensors in applications where the sensors are routinely damaged by impact. The one-piece housing is made from high-grade stainless steel which resists corrosion and is rated IP67 against moisture ingress. The standard temperature rating for the line is -25 to +70°C.

The rugged construction and design of the stainless steel sensor line allows it to fit the needs of a wide variety of applications. PTFE or WeldGuard coating is available on request.

**Turck Australia Pty Ltd**  
[www.turck.com.au](http://www.turck.com.au)

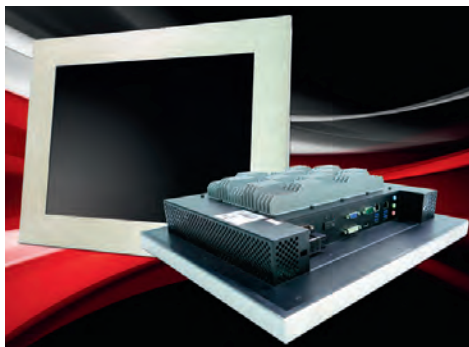

**PANEL PC**

Perfectron's LIF Series fanless rugged panel computer design has an Intel CPU onboard and supports a wide range operating temperature range of -30 to + 60°C and a wide range voltage input of 9–24 VDC or 100–240 VAC (optional). The specially designed anti-removal USB port at the rear of the panel PC provides a secure space for a USB connection and avoids unexpected removal or theft. The LIF series supports a rich I/O feature set such as VGA, DVI, COM, LAN, USB, audio, and also an mPCIe expansion slot.

The LIF series is based on the Intel Atom/Core i7 processor and feature a high-brightness LCD panel for easy readability under industrial conditions. The 15" LCD supports XGA resolution (1024 x 768) with a 5-wire resistive touch panel, making it suitable for HMI applications such as automation, and warehouse management.

**Backplane Systems Technology Pty Ltd**  
[www.backplane.com.au](http://www.backplane.com.au)

**PROCESS CONTROLLER**

To keep up with changing plant standards, Cerlic has released a 24 VDC version of its centralised BB2 controller.

Still capable of managing up to four separate sensors with any combination of the X-Series sensor range of suspended solids (ITX, CTX-LC and ITX-IL), dissolved oxygen (O2X Duo), pH (pHX) and redox (ReX), the low-voltage DC unit is reverse compatible with existing Cerlic equipment and can directly replace a line voltage unit as part of an upgrade, with no further hardware required. The Swedish-built BB2 provides up to four 4–20 mA analog output channels with the option of Profibus DP for digital control circuits. As for the line voltage (240 VAC) model, there are still two independent (dry contact) relays in the BB2 that can be programmed for high/low alarms or to trigger the self-cleaning of sensors with pressured air or water.



**Control Components Pty Ltd**  
[www.controlcomponents.com.au](http://www.controlcomponents.com.au)

**PROGRAMMABLE Incremental and Absolute Encoders**



**New!**



**PCA**

[www.pca-aus.com.au](http://www.pca-aus.com.au)  
+ 61 2 9482 3733

**Features**

- Program with a mobile phone
- No software to install
- Wi-Fi connection to encoder
- Online storage of configuration
- Range of housing sizes 58, 40 and 36mm

**Options**

- Incremental Only
- Absolute single or multi turn
- Gray or Binary Code
- Dual Incremental and Absolute
- Any values 1 to 16,384



## INLINE GAS ANALYSERS

Mettler Toledo has announced four additions to its range of tunable diode laser (TDL) spectrometers.

TDLs offer low-maintenance gas analysis in chemical and petrochemical processes. Being a non-contact measurement technology that requires no moving parts, TDLs can often be more dependable and process-tolerant than alternative technologies requiring sample extraction and conditioning. The technique uses a laser,

tuned to absorption lines of the gas to be measured, that passes through the matrix to a receiver. Analysis of the laser light reveals the level of the target gas.

Unlike cross-stack TDL designs, the GPro 500 series uses a probe that protrudes into the gas stream. A corner cube at the end of the probe directs the source laser beam back to the receiver in the analyser's head. This design simplifies installation and negates the need for beam alignment that can be an issue with cross-stack TDLs.



The GPro 500 has been available for O<sub>2</sub>, CO and moisture measurement. Now, models for O<sub>2</sub> plus temperature, CO%, CO<sub>2</sub>% and a combined CO<sub>2</sub>% plus CO% make the full GPro 500 range suitable for refinery processes where paramagnetic and extractive NDIR analysers are normally used. These applications include catalyst regeneration in fluidised catalytic cracking units, and ethylene oxide and purified terephthalic acid production.

For processes where low-range extractive measurement is required, Mettler Toledo has also announced a White cell adaption that provides an effective path length of 10 m and boosts measurement resolution by a factor of 10.

**Mettler-Toledo Ltd**  
[www.mt.com](http://www.mt.com)



## Druck Temperature Calibrators from GE

Provide solutions for testing devices from an icy -35°C to a blazing 650°C



**From ice to fire**  
with great accuracy and stability



Comprising four individual models, the Druck Temperature Calibrators combine the portability of dry block calibrators with the flexibility of liquid immersion baths to enable the testing and calibration of virtually any type, shape and size of sensor.

For more information, please contact [infoIndustrialAU@thermofisher.com](mailto:infoIndustrialAU@thermofisher.com), call 1300 735 295 or visit [www.thermofisher.com.au/GE](http://www.thermofisher.com.au/GE)



Multifunction

Pressure

Temperature

Software

**ThermoFisher**  
SCIENTIFIC

## INDUCTIVE SENSORS

The C23 Full Inox series of flat, full metal inductive sensors is designed for applications where the environment is harsh and space is scarce, but long operating distances (up to 7 mm) are still required.

C23 Full Inox Extreme sensors offer the advantage of factor 1 on steel and aluminium, and with this sensor's embeddable all-metal housing in stainless steel, shock, vibration or aggressive chemicals can do no harm. Two drill holes ensure that C23 Full Inox sensors can be installed very easily from the front. ASIC technology guarantees consistently long operating distances, quick installation and temperature compensation. In addition, it also contributes to vibration resistance, thus ensuring a long service life for the sensor. The IO-Link interface offers the user various parameterisation and diagnostic options. For example, it is possible to switch between NO and NC operation or to program an ON or OFF delay. Typical areas of application for the C23 sensor include grippers, clamping devices and gantry robots.

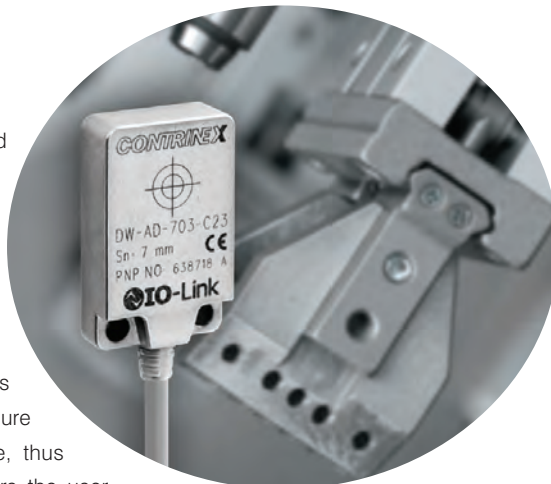

**Micromax Specialists in Automation Pty Ltd**  
[www.micromaxsa.com.au](http://www.micromaxsa.com.au)



Call for a **FREE** copy of our 2016 Test & Measurement Catalogue

# The All-in-one Tester for Bus Physics and Communication

Rent the Softing BC-600-PB Profibus Tester 4, PB-T4 from TechRentals

### Features:

- ✓ Automatically detects baud rate or open circuit voltage
- ✓ Live testing of PROFIBUS segments
- ✓ Master simulator
- ✓ Topology scan
- ✓ Frame analysis



**\$ Save with our NEW long term rental rates**



**For more information, contact us today:**

☎ 1800 632 652    ✉ [rent@techrentals.com.au](mailto:rent@techrentals.com.au)    🌐 [www.techrentals.com.au](http://www.techrentals.com.au)



TR1519



# WIRELESS NETWORKS

## IN THE WATER AND WASTEWATER INDUSTRIES

Wireless networking continues to gain acceptance in industrial applications, including the water and wastewater industries.

**W**ith the cost of copper continuing to rise, and wireless manufacturers creating newer products that are reliable and easy to implement, the use of wireless devices is continually growing. Reduced infrastructure, simplified network installation and commissioning, enhanced reliability via flexible, self-healing topologies, increased efficiency and reduced labour costs also contribute to its growing popularity.

Wireless monitoring and control can provide benefits for new installations or retrofit projects. Typically, the most obvious benefits are significant cost and labour savings that result from the elimination of cables, conduits and the work required to install and maintain them. The ease of wireless installation also allows for a reduced start-up phase for a project, meaning that the plant can be operational in less time than for a wired network. With the ability to sprinkle battery-powered sensors where they are most needed in the plant for the gathering of more information about the process, it is possible to improve process monitoring and to enhance diagnostic data that is useful for maintenance regimes.

Wireless is generally suitable for plants of most sizes and its inherent flexibility makes it easy to expand a small network. There can also be benefits in adding a wireless network to existing wired

installations. For example, the modular nature of some systems allows the user to have the choice of a fully wired loop for control and monitoring, a fully wireless control and monitoring system or wired control with wireless monitoring.

When considering wireless for monitoring and control or for monitoring only, it is recommended that a site survey be conducted to set the stage for a successful installation. Companies may offer tools and software to assist with a site survey and provide survey technicians that can inspect a potential site for possible problems specific to a wireless installation and make recommendations to overcome them.

One of the most important things to check is the viability of reliable wireless communication between field units and the control room. Some situations may require a site trial in addition to a survey to make sure wireless technology can meet special demands.

The experience of a large wastewater treatment plant in the UK which faced a significant problem is a good example of how wireless networking can help. The plant needed to retrofit valve actuators that controlled scum skimmers on several aeration tanks. Originally, the actuators were hardwired to the control room through a conduit that was embedded in concrete. To hardwire the actua-



© StockAdobe.com/au/luastodpphoto



THE WATER AND WASTEWATER INDUSTRIES CAN TAKE ADVANTAGE OF THE SIMPLIFIED SITE WIRING PROVIDED BY WIRELESS NETWORK CONTROL.

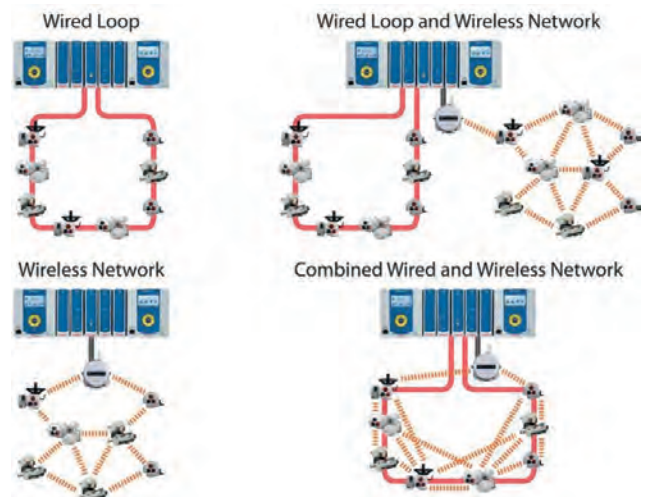

Figure 1: Wired and wireless network options.

tors for network control, the plant was presented with two very expensive options. The first was to demolish the existing concrete structure to install new conduit and then rebuild it. The second was to run external conduits on the surface of the structure. However, in order to avoid trip hazards and other health and safety issues, all external conduits needed to be clear from walkways. Therefore, any new conduit would need to be located along the edge of the aeration basins. If that option was selected, the basins would have to be decommissioned during installation.

In both cases, the plant faced considerable costs. With an average distance of over 100 m from actuator to control room, plus the associated cost of decommissioning the tanks during construction, the estimated cost to run the new wiring was in excess of £1 million. The plant therefore decided to install a wireless solution, which was achieved at a fraction of the estimated cost of the hardwired options. In addition to eliminating the need for control wiring, another major benefit has been the ability of the wireless-equipped actuators to communicate vital actuator data logger information to the host control system for planned maintenance and troubleshooting. Data transmitted wirelessly includes valve torque profiles, operational start profiles, vibration and temperature

trend logs, and an event log. Specific asset management information includes running time, average torque, number of starts and service or maintenance alarms.

Although this example involves valves, wireless technology is equally suitable for many diverse water industry applications including pump station control, water quality monitoring, leakage detection in distribution networks, flow metering, rainfall monitoring, tank level monitoring, treatment plants, storm tanks and large-network SCADA and distributed control systems, camera surveillance and intruder alarms. In conclusion, it can be said that advances in wireless technology have proved themselves to be reliable, secure and cost-effective. While it is true that some applications may not be suitable for wireless control, virtually every plant manager should become familiar with the technology and carefully consider its use when the time comes for a major upgrade, a new installation or simply extending an existing system. It works well and can result in substantial cost savings and productivity benefits. In fact, the installed cost benefit of wireless technology is too appealing to be ignored whenever a new or retrofit installation is under consideration.

**Rotork Australia**  
www.rotork.com



## Vic water utility upgrades SCADA network

The main focus for improving capabilities has been the SCADA systems — especially through proactive asset management and data analytics. While there are many opportunities to save costs and increase efficiency by enhancing these functions, it can be just as risky if the framework for improvement isn't aligned with business needs.

Coliban Water is one of these major utility organisations focused on transforming its SCADA capabilities. A regional water authority that covers 16,500 km of central and northern Victoria, Coliban Water manages more than 350 sites that comprise water treatment plants, water reclamation plants, pressure monitoring stations, sewer pumping stations, water pumping stations and flow meters.

"Currently, the maintenance of our remote terminal units and SCADA hardware out in the field is outsourced to our private partner, Lendlease. We manage all communications, but issues that arise within our RTUs are outsourced, including repair works onsite," explained Dan Smith, SCADA manager at Coliban Water.

Smith's team comprises three specialists including himself, and is responsible for all site communications and SCADA software systems, including CITECT, ClearSCADA and related network diagnostic systems. The team is managing three improvement phases that will transform the main SCADA system into an integrated and responsive set-up.

RTU management is usually conducted in-house, Smith is quick to note, but up until three years ago, every part of SCADA management at Coliban Water was outsourced.

"We're on a path to consolidate many of the management and repair functions in-house. That's why we're starting with the communications network."

The majority of the network previously ran on an analog UHS system, which had several limitations including low speed, limited visibility on network activity and performance, and no ability to remotely manage assets in the field.

By upgrading to a digital UHS system, Smith and his team will be able to carry out firmware upgrades remotely, manage devices remotely, change power and increase speed throughput 10-fold. This will make it far easier to manage the network, as well as provide more reliability.

While the first stage involves communications and upgrading to digital technology (currently underway), the second stage has just been completed — shifting to an open-protocol network instead of a proprietary one. The move is an important foundational step to enabling the network to support DNP3.

Now having successfully moved to an open protocol, the team can perform an upgrade and implement an RTU platform anywhere in the network.

"It's been a big benefit and has given us a lot of freedom to trial different technologies. We're not locked into one vendor for RTU platforms anymore," said Smith. The priority for his team in the context

of benefits is enabling DNP3 event-based reporting. Traditionally, the way data was obtained involved sequential polling across the entire network — in effect, polling for static information every two hours. The planning team would also have to go out and install multiple data loggers at specific sites for a limited period of time, because the quality of information coming back from the network was relatively poor and unreliable.

"There will be significant cost savings once we completely change how we maintain assets on a daily basis. There are many flow-on effects from what we're doing."

The third phase of SCADA improvement relates to rolling out new RTU platforms that support DNP3, which will provide higher quality

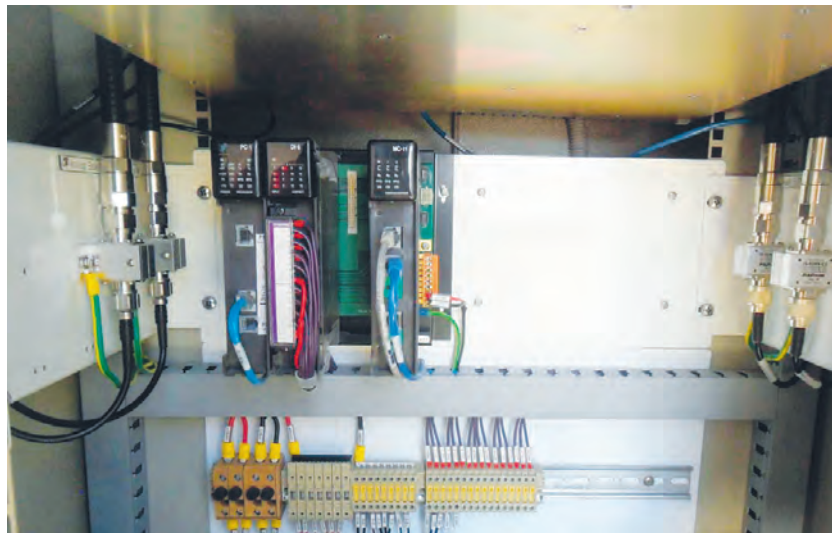

data to the business. This phase, which has just begun, will take approximately three to four years across all sites.

"Our SCADA system was primarily set up as a monitoring and alarming system, but now there are more business units across the organisation that want higher quality data, more resolution. And that's where we're struggling, because we have a lot of old tech in the field and not entirely event-based," explained Smith.

"We'll get the double benefit of increased throughput from the site, in terms of monitoring and data management, and RTU software standardisation. It's a pretty important project, and probably our biggest focus for the next two or three years," he remarked.

Coliban Water's effort to enhance its SCADA system is as much a response to current business needs as it is to that of the long-term objectives. Smith's team is already looking at obsolescence issues in 2023, because the budgets are already being planned for that period.

*Presenting at SCADA 2016 24–25 May 2016, Dan Smith will be joined by specialists from organisations including Jemena, Qld Urban Utilities, Dalrymple Bay Coal Terminal and more.*

**SCADA Australia Conference**  
[www.scadaaustralia.com.au](http://www.scadaaustralia.com.au)



## SAFETY SHUTDOWN VALVES

Bürkert has expanded its Type 8640 valve island and the Type 8644 automation system to include new versions of the Type 6524 and 6525 pneumatic valves for safety-related shutdown. These valves enable the safe shutdown of processes up to performance level c.

In conformity with the Machinery Directive, the valves are designed for all applications with special requirements for process safety. This includes the food and beverage industry, pharmaceuticals and chemicals, as well as industrial water systems. The components are installed in emergency systems for immediate process shutdown for example, as well as for increased safety in processes involving high temperatures and hot vapours.

In general, Bürkert valve islands and automation systems are suitable for use in many different types of hygienic process environments due to the integrated process safety features of the Type 8640 valve island and the Type 8644 automation system. Check valves integrated in the exhaust air duct guarantee that in the event that all actuators are shut down simultaneously during a disturbance in the system, no back pressure can accumulate in a valve block, which could result in unwanted switching of a process valve, with serious consequences for the process. A hot-swap function allows replacement of faulty valves even during operation, without the risk of loss of air pressure on the entire valve block. The combination of a valve terminal or automation system with the AirLINE Quick adapter provides an especially compact system solution for even more flexibility in a smaller space.

### **Bürkert Fluid Control Systems**

[www.burkert.com.au](http://www.burkert.com.au)



**NEW  
EXTENDED  
RANGE**



# APEX BY BREDEL

## LOWER TOTAL COST OF OWNERSHIP

Seal-less, valve-less hose pumps  
with unmatched flow stability

Hose elements replaced in-situ,  
in minutes

Reduced cost of ownership  
compared to AOD and PC pumps

Optimised for maximum hose life  
at 8 bar, with flows to 6,200 litre/hr

**Bredel**

*Hose Pumps*

[wmftg.com.au](http://wmftg.com.au)  
1300 9627 8677

**WATSON  
MARLOW**  
Fluid Technology Group

## PERISTALTIC CASED PUMPS

Watson-Marlow Fluid Technology Group has introduced the 530 peristaltic cased pump for metering and transfer applications such as surface coating, printing and lime addition. The pump offers easy operation and versatility coupled with high levels of accuracy.

The models are designed to meet the demands of rugged and often remote environments and are built to operate 24/7 without interruption. It is possible to quickly check control parameters and avoid errors with visual status through a bright colour display, while an intuitive menu structure makes for confident and easy operator interaction. Integrated Profibus networking capabilities offer two-way, real-time communications, increased diagnostic capability and faster response.

The range of process pumps offers four drive options and nine pumphead variants. This enables users to choose from manual operation to fully automated control, including the ability to link up to 16 pumps and provide real-time communication.

The pumps deliver flow rates from 0.0001 mL/min to 3.5 L/min. It is the pumphead that determines both the flow rate and the pressure that can be achieved to match the needs of the specific process. The pumps can be fitted with either continuous tubing pumpheads, or with LoadSure tube element pumpheads for pressures up to 7 bar.

The pumps have no seals, valves or diaphragms and do not suffer gas locking, corrosion or clogging. Chemical-resistant Marprene industrial-grade thermoplastic elastomer tubing offers wide chemical compatibility and long life, along with low gas permeability.

**Watson-Marlow Fluid Technology Group**

[www.wmftg.com.au](http://www.wmftg.com.au)



### Reliable pump and valve control delivers switched on level solutions

- No more tangles – up to four switches in one float
- Choice of three different sized floats to ensure enough buoyancy for your application – ranging from clean to black water.
- Wide range of output configurations: high / low level alarm, pump control & gold plated contacts for low voltage / current applications (e.g. battery powered telemetry systems).
- Perfect for sumps, sewage, water & wastewater treatment, power stations & silo (solids) monitoring

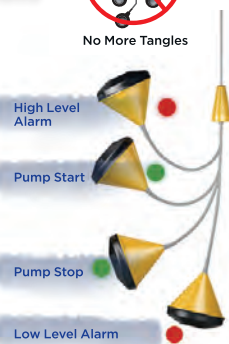

## HYGIENIC LEVEL SENSOR

The LR2750 level sensor from ifm efector was specially developed for food industry applications and features a hygienic design that resists aggressive cleaning processes. The sensor is equipped with an Aseptoflex Vario thread to suit many process adapters and its accuracy is not affected by reflective foams.

Due to the use of high-quality and insensitive sealing materials such as PEEK and EPDM as well as a high-grade stainless steel housing, the level sensor is suited to internal and external cleaning. It has a protection rating of IP69K, an enhanced pressure resistance up to 40 bar and is also rated for high-temperature media up to 150°C.

An optional tank adjustment ensures the flexibility of the LR2750. Even if installation is difficult, such as at the connection piece of a tank, the device operates precisely and without problem. Because of the possibility to shorten or replace the probes at the customer's end, it is not necessary to have several probe lengths in stock when various tanks are used, facilitating replacement. Whether smaller storage tanks, expansion tanks, separators or for filling, the LR sensor can be used almost everywhere.



**ifm efector pty ltd**

[www.ifmefector.com](http://www.ifmefector.com)

**CCEZY.COM.AU +61 2 9542 8977**  
Distributors through Australia and New Zealand



# WATER: FOR LIVEABLE COMMUNITIES AND SUSTAINABLE INDUSTRIES

Australia's water industry has seen significant change over the last decade, with the introduction of water recycling, considerable developments in water efficiency and many cities now having a desalination plant. Ageing infrastructure and climatic pressures on water mean this change will likely continue, particularly as a booming population is predicted to double over the next 50 years.

Ozwater'16 will once again bring together the brightest minds, innovators and enablers in water and wastewater for a three-day conference to uncover and explore the challenges and opportunities facing the water sector now and in the future.

The event attracts speakers from across the country and internationally, from leading water professionals, commercial and business honchos, industry leaders, technology entrepreneurs and academic masterminds. They will share their knowledge of both local and global issues as they relate to water, putting a spotlight on sustainability issues. This year the conference agenda is packed with additional streams relating to current issues including liveability and sustainability of the future.

In addition to the comprehensive conference program, there is also a workshops program and trade exhibition. The trade exhibition is free to attend from Tuesday 10 to Thursday 12 May. It features more than 200 exhibitors showcasing water-related products, services and innovations from international and national companies.

Keynotes include:

- Kerry Bodine — writer and customer expert, co-author of *Outside In: The Power of Putting Customers at the Center of Your Business*
- Professor John Thwaites — Chair of ClimateWorks, Chairman of Melbourne Water
- Andrew Geczy — CEO, International and Institutional Banking, ANZ

With over 150 platform presentations, the event will see dedicated streams on Liveable and Sustainability Cities of the Future, Sustainable Industries, Customers and Communities and Water for Rural, Remote and Regional Communities. Presentations include:

- Moving wastewater treatment facilities to resource recovery facilities — Dr Art Umble of MWH, Denver, USA
- Beyond benchmarking: a water sensitive cities index — Lindsey Beck, LindseyB
- Outcomes from integrated water planning — Robert Considine, Melbourne Water
- Using market-based instruments to deliver cost-effective storm-water management outcomes — Jeremy Cheesman, Marsden Jacob

- Generating liveability benefits from investment in water authority land assets — Kym Whiteoak, RMCG
  - The role of climate-resilient water sources in Australia — Matthew Hardy, Bureau of Meteorology
  - The role of renewable energy in the Australian water sector — the water-energy nexus — Wayne Goodwin, Beca
  - Tropical highs: applying lessons learnt from existing groundwater recharge schemes to inform Northern Australia's proposed increasing demand for water — Carly Waterhouse, CH2M
  - Sustainable mining operations and the prospective role of membrane bio-reactor in mine water management — Amos Branch, UNESCO Centre for Membrane Science and Technology, UNSW
- Ozwater'16 will also feature workshops on:
- Transitioning to a water sensitive city — part 1 and 2, presented by CRC for Water Sensitive Cities
  - Validating water treatment in integrated water management: introducing 'Waterval', presented by the Australian Water Recycling Centre of Excellence
  - Future water infrastructure investment — where will the money come from?, presented by Aither Pty Ltd
  - Enhancing business outcomes through education — Australian Water Association Water Education Network

## Details at a glance

Ozwater'16 is supported by Principal Sponsors Suez and Melbourne Water.

**What:** Ozwater'16 international water conference and exhibition  
**Where:** Melbourne Convention and Exhibition Centre  
**When:** 10-12 May 2016  
**Web:** [www.ozwater.org](http://www.ozwater.org)

Register for the free trade exhibition at [www.ozwater.org/tradevisitor](http://www.ozwater.org/tradevisitor).

**AWA**  
[www.awa.asn.au](http://www.awa.asn.au)

**TEMPERATURE TRANSMITTER**

The WIKA model T15 digital temperature transmitter comes in both head-mounted and rail-mounted versions. It offers analog output process signals from resistance sensors (Pt100 and Pt1000) and potentiometers.

It is ready for operation in less than three seconds and offers a high basic accuracy of 0.1% of span at a measuring rate of up to 20 measured values per second. The product fulfils high standards of safety, eg, in accordance with NAMUR recommendations on EMC protection, signalling and sensor-break monitoring. It has been certified to the latest EMC protection standard, DIN EN 61326-2-3:2013. In addition, it offers ATEX and IECEx approvals for use in hazardous areas.

With WIKAsoft-TT software, the transmitter can be programmed intuitively. The simple operation is supported through a case with sensor connection from the outside, a large clamping area of up to 2.5 mm<sup>2</sup> and an imprinted pin assignment. The instrument can be used for diverse applications in machine building, plant construction and the process industry.

**WIKA Australia**  
[www.wika.com.au](http://www.wika.com.au)



**HANDHELD OSCILLOSCOPE**

The Fluke ScopeMeter 120B Series industrial handheld oscilloscope is designed to address the challenges of troubleshooting complex industrial machinery with features that improve the speed and efficiency of troubleshooting complex electromechanical systems.

The compact series features Fluke's Connect-and-View technology, which recognises signal patterns and automatically sets up the scope's triggering, amplitude and time base, eliminating the typical trial-and-error set-up process. Once the waveform is captured, IntellaSet intelligent measurement detection automatically selects key measurements based on the acquired waveform type and displays the most relevant measurement values (for example,  $V_{rms}$  and Hz for a line voltage signal or  $V_{p-p}$  and Hz for a square wave), helping technicians easily identify and characterise potential signal faults.

The series also features an event capture function that captures and identifies elusive intermittent events and lists all those events that exceed a predetermined threshold. This lets technicians identify key events quickly, rather than combing through large data sets, reading by reading.

As part of Fluke Connect, a system of wireless test tools that communicate via the Fluke Connect app, or Fluke Connect Assets software, a cloud-based solution that gathers measurements to provide a comprehensive view of critical equipment status, the series can automatically record waveform data to the Fluke Connect app on smartphones or tablets, eliminating manual recording of data.

The wireless series also lets technicians place the meter in locations that are difficult to access or are potentially hazardous, then take measurements from a safe distance.

**Fluke Australia Pty Ltd**  
[www.fluke.com.au](http://www.fluke.com.au)

**ZS3G-SMS Cellular I/O Controller**

- Pumps
- Motors
- Generators
- Refrigerators
- Freezers
- Fans
- Lighting
- HVAC systems
- Data centre alarms
- PLC I/O

**ZS3G-SMS** is an out of the box SMS I/O controller that communicates over the 3G cellular network. User can remotely monitor and control, pumps, motors, gates, PIVOT irrigators, refrigerators, fans, PLCs and much more. The SMS I/O controller sends alarms in SMS text format to multiple users and accept remote commands & acknowledgements. Pulse counting, Tank level, Pressure and Temperature sensors can be interfaced directly to the 3G controller.

- Irrigation systems
- PIVOT alarms
- Poultry house alarms
- Cold storage alarms
- Gas alarms
- Garage doors control
- Domestic alarms

**ZigSense** ↔ **ZigCloud**

ZigSense and ZigCloud are business units of Conlab Pty Ltd  
13/1020 Doncaster Road, Doncaster East, Victoria 3109 Australia  
Ph: +61 3 9842 7711 Fax: +61 3 9842 7511  
[www.zigsense.com.au](http://www.zigsense.com.au) Email: [info@zigsense.com.au](mailto:info@zigsense.com.au)

## DUAL REDUNDANT GAS FLOW METERS

Emerson Process Management has announced a Daniel gas ultrasonic flow meter platform that provides two British Gas meters and transmitters in a single body. Designed to permit two completely independent measurements with the installation of a single flow meter, the Daniel 3415 (four-path + one-path) and 3416 (four-path + two-path) gas ultrasonic flow meters combine a four-path fiscal meter with an additional check meter, while the 3417 (four-path + four-path) meter provides two fiscal meters for full redundancy and equal accuracy within one meter body.

Both the Daniel 3415 and 3416 gas ultrasonic meters measure flow using four horizontal chordal paths in addition to a reflective path dedicated to verification of the primary measurement. The 3416 meter is also equipped with an additional vertical reflective path to detect liquid or very thin layers of contamination at the bottom of the meter that otherwise remain completely hidden in a direct-path meter design.

The Daniel 3417 gas ultrasonic meter has a dual-plane configuration that combines two independent four-path British Gas fiscal meters into one meter body. The 3417 meter is suitable for border stations that are becoming bidirectional, storage applications, remote locations such as offshore platforms or for use on large compressor stations or lines without a bypass.

All meters are approved to the more stringent class 0.5 of OIML R137 MID accuracy. In addition, they feature redundant electronics with a patented transducer synchronisation function, which coordinates the acoustic firing of both meters to avoid interference between them.

**Emerson Process Management Aust P/L**

[www.emersonprocess.com.au](http://www.emersonprocess.com.au)

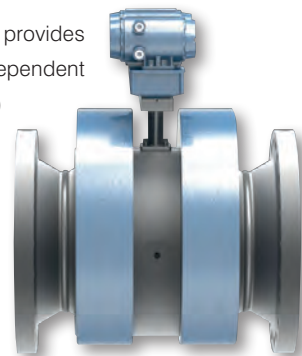

## Saving energy made easy.

Minimising carbon footprint in pharma production has never been easier: A tube valve body is an innovative energy saver. It outperforms forged bodies by far. With less weight, it heats up and cools down much faster – saving you steam, time and energy in CIP and SIP processes. Imagine that saving multiplied by every single diaphragm valve in your plant.

Tube Valve Bodies –  
for more efficient processes

**We make ideas flow.**

[www.burkert.com.au](http://www.burkert.com.au)





# WARNING

Not suitable for repairing flimsy connectors (or your reputation).

**Rugged, reliable industrial automation products** from Turck are built to perform in the toughest conditions, and our engineered solutions are customised to meet your application challenges. Cheap knock-offs can't compare. **Turck works!**



### Overmolded Mil-Spec Connectors

A full range of easy, quick connection for instrumentation and power applications. Diminished risk of mis-wiring means cost savings, decreased downtime and fewer repairs.

Call 1300 132 566 or visit [www.turck.com.au](http://www.turck.com.au)

### RADAR TRANSMITTER FOR BYPASS CHAMBERS

The OPTIWAVE 1010 radar level transmitter is designed for bypass chambers and magnetic level indicators. The 2-wire FMCW radar level transmitter is designed for the continuous level measurement of liquids in bypass applications in various industries, such as chemical, power, water and wastewater.

The product can be combined with the Krohne BM 26 ADVANCED bypass chambers and magnetic level indicators (MLI), thereby adding a 4–20 mA HART output to the mechanical devices. The combinations can be ordered as a whole or it can be welded on any bypass chamber with an internal diameter of 38–56 mm.

The unit is designed as an alternative to reed chains and magnetostrictive or simple TDR transmitters that are typically used with bypass chambers or MLIs. In addition to a measuring accuracy of  $\pm 5$  mm, the FMCW principle is claimed to offer a better overall accuracy in bypass applications because it directly measures the liquid surface.

Applications include almost any liquids with process temperatures  $\leq 150^{\circ}\text{C}$  up to 580 psig and measuring ranges up to 8 m. With clean liquids of dielectric constant  $r \geq 3$ , the device measures the surface directly. For  $r < 3$ , a float with target is used.

The product features a dual process seal system that allows for the removal of the converter under process conditions. The 2-wire, loop-powered HART device is preconfigured in the factory and delivered ready to use. Application-specific adjustments are possible via HART/DD and DTM.

**KROHNE Australia Pty Ltd**  
[www.krohne.com.au](http://www.krohne.com.au)



## HUMIDITY VALIDATOR

The HygroCal100 humidity verifier from Michell Instruments provides a practical option for companies that are not able to invest in a full humidity calibration laboratory to verify their humidity probes in-house. The unit is cost-effective and is available either on its own or with a choice of options to meet a variety of needs.

On its own, the HygroCal100 provides a simple way to validate humidity probes on-site. Weighing just 3.2 kg and with a battery life of up to 8 h, it is easily portable. It is capable of validating up to seven probes of different sizes simultaneously and has a simple automatic validation program that allows the operator to 'set and forget' while the unit is working.

While the HygroCal100 comes with its own internal reference, it can also be integrated with any hygrometer with an analog output to act as an external reference. This gives users the flexibility to incorporate their traceable reference units in their validation routines.

The unit is also available as part of a package to enable users to start making traceable calibration checks immediately. One option supplies the HygroCal100 with an Optidew Vision chilled mirror hygrometer, which provides a fundamental reference. The kit includes port adaptors to fit both the dewpoint and temperature sensors into the chamber.

**AMS Instrumentation & Calibration Pty Ltd**

[www.ams-ic.com.au](http://www.ams-ic.com.au)



**Weidmüller** 

## Powerful supplies for demanding systems

### PROmax offers flexible solutions for ambitious automation

The PROmax range of switchmode power supplies deliver in demanding applications. Slim yet powerful, PROmax can absorb continuous overloads of up to 120% for 1min or transient peak loads of 300% for 2ms. Whether used in large machines, power systems or process plants, PROmax can be deployed worldwide thanks to their wide operating voltage to 277Vac, surge category III, and a host of approvals by cURus, cULus, RCM, GOST, SEMI F47, CCC, GL (EMC1), C11Div2 and TÜV-certification. Available in single phase connection for 5, 12, 24, and 48V models and three phase for 24V with change over contact for fault / overload monitoring. Let's connect

[www.weidmuller.com.au](http://www.weidmuller.com.au)

**TOUCH BUTTONS**

Banner Engineering has introduced its next-generation touch buttons for its K30, K50 and K70 multicolour indicators and pick-to-light sensors. Employing smart electric field sensing, the next-generation touch buttons provide high immunity to false triggering caused by the build-up of detergents, oils and other foreign materials, as well as exposure to direct water spray.

Featuring a 70 mm touch dome with a 30 mm base, the K70 touch is optimal for larger industrial applications in addition to jobs that require more visibility. The K70 is available in nine colour options and one-, two- and three-colour models for flexible performance.

The next-generation K30 and K50 offer flexible communication and simplified set-up of a single device or multipoint applications. The K50 is available in one-, two- and three-colour models, while the K30 is available in one- and two-colour models. FDA models are also available, which are constructed from FDA-grade material and fully encapsulated for use in food and beverage applications.

In addition to high immunity, next-generation K30, K50 and K70 indicators are ergonomically designed to eliminate hand, wrist and arm stresses associated with repeated switch operation, requiring no physical force to operate. The indicators can also be easily actuated with bare hands or in gloves.

Momentary and latching versions are available. Momentary configurations remain activated as long as touch is present, while latching models start up inactive and toggle between activated and not activated on successive touches. All models feature fully encapsulated IP67/IP69K construction for optimal performance in high-pressure washdown environments.

**Turck Australia Pty Ltd**  
[www.turck.com.au](http://www.turck.com.au)



**Intelligent UPS system for superior system availability thanks to IQ technology**

Uninterruptible power supplies (UPS) continue to deliver power even in the event of mains failure.

With our IQ technology, you are one step ahead:

- ✓ Know the state of charge & remaining runtime of your power storage
- ✓ Be warned about failures at an early stage and have time to prevent them
- ✓ Maximize the service life of the power storage
- ✓ Transfer all relevant information to your computer and higher-level controllers

[phoenixcontact.com.au/UPS](http://phoenixcontact.com.au/UPS) | 1300 786 411

**PHOENIX CONTACT**



## MODELLING SOFTWARE

CD-adapco has announced STAR-CCM+ v11.02, providing updated modelling capabilities as well as productivity and usability enhancements.

The product introduces Data Focus, a visualisation technique to explore and interrogate results interactively. Data Focus provides an interactive link between quantitative numerical data in plots and qualitative visual data in scenes. This link allows the user to easily and effectively gain insight into the key influences on product performance.

STAR-CCM+ v11.02 includes 40 added features drawn from ideas submitted through IdeaStorm, the forum exclusive to CD-adapco users. These features elevate confidence with results, streamline simulation workflows and increase productivity.

Local Surface Remeshing allows for remeshing only selected areas when changing mesh parameters or performing design changes, reducing surface mesh generation time up to an order of magnitude. Native Cylindrical Primitive Particle Types in DEM reduces turnaround time and improves accuracy by representing particles, such as tablets or pellets, using true cylinders as opposed to a collection of spheres.

Co-extrusion in Computational Rheology expands the application scope of STAR-CCM+ to include complex extrusion processes involving multiple material streams, while Hinged Multi-Body Motion allows for modelling of complex dynamic fluid body interaction scenarios where multiple parts are coupled together with common mechanical joints.

The company is also introducing a VPD tool for mixing problems called Admixtus. By using Admixtus together with STAR-CCM+, engineers in the chemical and processing industries will experience significant productivity gains through workflow automation and have the freedom to explore many designs early in the product development cycle.

**CD-adapco Australia**  
[www.cd-adapco.com.au](http://www.cd-adapco.com.au)

## LOAD CELL TRANSMITTER

The IQ810 transmitter from Instrotech combines load cell amplification, digital display and alarm relays with both analog retransmission and serial outputs. Providing excitation for up to six 350Ω load cells, the IQ810 is used in applications having one or more strain gauges which require retransmission and switching control. The versatile functions allow for use as a standalone unit, or with analog output to a PLC or with the RS232 and RS485 serial communications. The serial protocols include simple ASCII as well as Modbus RTU and Modbus ASCII. Advanced features include auto-zero tracking, linearisation, max/min recording, programmable front push-buttons, two programmable digital inputs, security lockout, motion indication and digital filtering. The 6-digit bright red alphanumeric LED display, plain language menus with prompts, 24-bit A/D front end and 16-bit retransmission are designed to make the IQ810 an accurate yet easy-to-use rail- or surface-mount instrument.

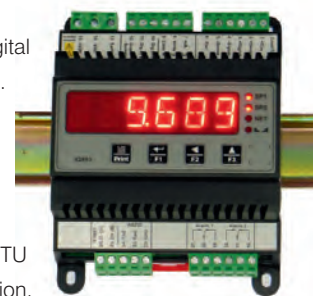

**Instrotech Australia Pty Ltd**  
[www.instrotech.com.au](http://www.instrotech.com.au)

## KNOW WHAT'S HAPPENING 24/7 WITH AX8

Intelligent, affordable condition monitoring

FLIR MSX Technology

AX8

The FLIR AX8 installs easily in electrical cabinets or other confined areas, giving you continuous temperature monitoring, hot spot detection, and alarming of critical electrical and mechanical equipment.

**AX8 gives you:**

- Multiple video options – thermal, visible, and MSX
- Continuous condition monitoring & automated temperature alarms
- Industry standard interfaces – Ethernet/IP and Modbus TCP
- Multiple streaming video outputs
- Small and rugged enclosure that's easy to install

Learn more about this powerful thermal sensor  
today at [www.flir.com/AX8](http://www.flir.com/AX8)

The images displayed may not be representative of the actual resolution of the camera shown. Images for illustrative purposes only.

[www.flir.com](http://www.flir.com)

The World's Sixth Sense™

FLIR Systems  
Australia Pty Ltd  
Phone: 1300 729 887  
(NZ: 0800 785 492)  
E-mail: [info@flir.com.au](mailto:info@flir.com.au)

OUR  
**PROCESS  
ANALYSERS**  
ARE  
DEVELOPED  
BY  
SCIENTISTS  
WITH A  
**PASSION**  
FOR  
**UNUSUAL  
PARAMETERS**

mep.net.au



Near Infrared Online Viscometry Titration Colorimetry



Density Sound Sensors COD/TOC

Whatever parameters you need to monitor:  
**Make sure you speak to our specialists!**

available at  
**MEP**  
instruments  
The right chemistry.

MEP Instruments Pty Ltd  
Australia Tel 1300 720 485  
New Zealand Tel 09 477 0620  
www.mep.net.au

A company of Metrohm and Anton Paar

## STAINLESS STEEL KEYBOARDS

Backplane Systems Technology has released the InduKey TKV-084-FIT-Touch-IP65-MGEH Series of stainless steel keyboards with integrated touchpads.

The range provides three compact versions in the TKV-084-FIT Series, which are suitable for use in tough industrial applications because of their robust design and high-quality workmanship.

These keyboards are suited to a variety of environments as the silicone seal between the top and bottom parts of the keys protects against any ingress of dust or splashing water. By integrating the keys in an additional membrane (consisting of silicone or PORON), it is possible to create a LABS-free version designed for medical and laboratory applications.

The flat key caps and the arrangement of the keys enable noise-free typing strokes and support fast touch typing. The capacitive keypad also allows precise operations for users, even if they are wearing silicone gloves. Customised modifications are available to meet the requirements of specific applications.

**Backplane Systems Technology Pty Ltd**

[www.backplane.com.au](http://www.backplane.com.au)



## VIBRATION LEVEL SWITCH

The OPTISWITCH 5300 C is a vibration level switch for liquids that provides overflow prevention, high/low level alarm, or dry run protection for pumps in liquid applications with a temperature range from -196 to +450°C and pressures from -1 to 160 barg. Insertion lengths are available up to 3 m with a wide variety of sensor materials and process connections. The wetted parts of the switch are made of Inconel 718 with 316L or Hastelloy C-22. Communication options include 2-wire 8/16 mA output, relay (DPDT) and transistor PNP/NPN electronics.

The level switch features Ex, WHG (German Wasserhaushaltsgesetz) and various ship approvals, and fulfils the requirements for use in boilers and auxiliary installations according to EN 12952-11 (water tube boilers) and EN 12953-9 (shell boilers). The OPTISWITCH 5300 C is designed for use in safety loops: as a single device for a single safety function (1oo1), it meets SIL2 architecture and in a homogenous redundant set-up, it meets SIL 3 (1oo2) architecture.

**KROHNE Australia Pty Ltd**

[www.krohne.com.au](http://www.krohne.com.au)

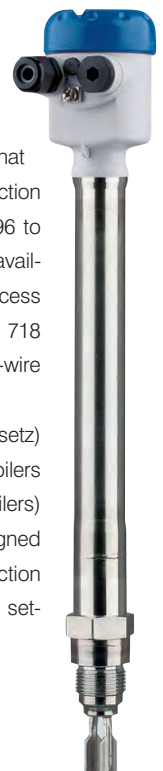

### RELATIVE HUMIDITY PROBE

The HygroSmart HS3 interchangeable relative humidity and temperature probe from Michell Instruments is 100% configurable to allow maximum flexibility to the user. This gives users the ability to alter their RH and temperature measurements to keep step with changes or developments in their process, with no extra costs.

Customers can set the zero/span range, output signals and choose from five output parameters (including dewpoint). All these changes and settings are easily made on a PC via the application software. For users who value simplicity above flexibility, they can order their probes fully configured to their specifications directly from Michell.

The probe also ensures zero process downtime by keeping maintenance to a minimum with an interchangeable sensor. When recalibration is due, the old HygroSmart HS3 sensor is simply exchanged for a new, freshly calibrated one. This is a simple procedure which allows the probe to remain installed and takes only a few seconds to carry out. Using the replaceable sensor ensures that the HygroSmart HS3 probe has a low lifetime cost, when compared to fully disposable probes. Alternatively, minor calibration adjustments can be easily made on any installed HS3 probe, with a 5-point digital trim adjustment via the application software to ensure maximum accuracy without needing to replace the sensor.

Designed for demanding industrial conditions, the HygroSmart HS3 probe features a solid corrosion-resistant body, 10 bar pressure sealing and IP67 pressure rating. In addition, it has an accuracy of 0.8% RH.

**AMS Instrumentation & Calibration Pty Ltd**  
[www.ams-ic.com.au](http://www.ams-ic.com.au)







**ifm efector**



**SMARTOBSERVER**

Condition and energy monitoring

- Condition monitoring of machines and installations
- Analysis of the energy consumption
- Organisation of maintenance
- Quality assurance of the produced products

**ifm – close to you!**

[www.ifm.com/au](http://www.ifm.com/au)  
 Phone 1300 365 088

# MEETING EMERGING CHALLENGES IN MANUFACTURING WITH LIGHTWEIGHT ROBOTICS

## PART 2



The trend toward adaptive, low-volume, high-mix manufacturing presents a challenge to manufacturers, as current technologies in automation — based on the principle of high volume and minimal change — cannot readily adapt to meet the rapidly changing needs of the market. Lightweight robots can help alleviate these challenges.

As discussed in Part 1 of this article, today's global marketplace has changed and continues to change the dynamics of manufacturing. For those manufacturers who have moved facilities abroad to leverage lower labour costs, the realisation is rapidly dawning that maintaining high-quality products using manual production methods is not a sustainable, long-term strategy. In addition, the trend towards mass customisation, with lower volumes and a higher product mix, creates the challenge of producing small lot sizes efficiently and meeting high-quality standards expected in today's market.

Advances in mechanics and controls are now enabling the practical and economical application of lightweight robotics for manufacturing on an increasingly broad scale.

### How lightweight robotics addresses the challenges

In Part 1 of this article, the main challenges for the flexible application of robotics were listed as part presentation, machine access, process rates, layout issues and cost. Point by point, the following is how lightweight robotics is fitting into the manufacturing process by addressing these challenges:

- **Part presentation:** While conventional vibratory solutions may work for some applications, they don't work for others. In those

cases, fixed trays or conveyors can be used as a staging area for the robot. The integration of vision-based solutions with robotic systems is proving to be the most flexible, lowest cost solution. Parts can be loosely positioned onto a tray, belt conveyor or vibratory belt where the vision system will determine the part location and orientation. The vision system then transfers the information to the robot, allowing it to pick up the part. The vision system eliminates the need for part location details or precision transfer devices, reducing the cost of processing a new part.

- **Machine access:** With the large variation of robot configurations available, many alternative system layouts are possible. An overhead robot can be a good solution for tending multiple machine tools. With proper guarding, it can allow manual access to each machine without shutting down the robot system. Many types of robot mounts, bases and positioners can also be designed to allow temporary repositioning of the robot for machine access. Collaborative lightweight robots enable the operator and robot to work side by side without the need for guarding or disabling the robot.
- **Process rates:** Piece rate is only one measure of an automation system. A more important measure of capability is net throughput. Robotic machine loading systems have proven to have a much higher percentage of uptime than comparable manual processes.



TODAY'S ROBOT MAY BE MORE THAN 20% FASTER THAN A COMPARABLE MODEL FROM FIVE YEARS AGO.

multiple processes in a production area. In many cases, what appears to be a situation of one operator per one machine can turn into one operator per three or four machines when the larger manufacturing picture is considered.

### Additional benefits of employing lightweight robotics

The implementation of lightweight robotics offers many additional, tangible benefits for manufacturers:

- Improved process control:** A properly designed automated process ensures that things happen when and how they are supposed to. For both regulated and non-regulated industries, this is essential to ensuring quality and meeting customer expectations. Hard benefits include reduced scrap, higher throughput and better responsiveness to volatile demand.
  - Improved machine utilisation:** A machine that is not running generates no income for the manufacturer. Typical machine usage for a manual machining process is 65%. For a comparable automated process, this number is greater than 90%. Better machine tool usage results in a faster return on investment for the machine tool while simultaneously improving production capacity.
  - Better use of labour:** The most flexible and valuable resource in any company is its people. Good use of that resource is not necessarily for machine tending, but for machine set-up and other operations that may not be suitable to automation.
  - Greater agility:** Today's global marketplace is distinguished by accelerating change and volatile, hard-to-predict demand. Leveraging robotic technology improves a manufacturer's ability to respond quickly and efficiently to these conditions, helping achieve the leaner, more agile operations essential to sustainable success.
  - Improved leverage to cope with macroeconomic trends:** Certain developments are beyond an organisation's control, such as economic recessions and recoveries as well as changing workforce demographics. This has implications for hiring practices, as does the growing shortage of skilled labour. Automation provides a hedge to allow increased production without precipitously adding to the labour force before the recovery is at a stage that warrants that, or before the workers you really desire are available.
- This additional uptime creates more available hours of operation per shift than the manual process, so a robot system with a slower piece rate can still have a much higher net throughput.
- Furthermore, robots continue to improve in terms of speed, reach and payload capabilities. Today's robot may be more than 20% faster than a comparable model from five years ago.
- Space and layout considerations:** As with the challenge of machine access, many space and system layout issues can be addressed with the variety of available robot configurations. One promising development is that recent changes to robotics industry safety standards allow safety-rated soft limits. Robots can now dynamically define operating space and restricted space based on the status of safety interlock signals. This allows tremendous flexibility in both system layout and access. In addition, robotic solutions are designed to be more compact and lighter for easy portability and reduced footprint.
  - Cost:** When justifying robotic automation, a range of factors must be considered — not just labour. A thorough return on investment evaluation must take into account all associated costs and savings, as well as changes in throughput. It can also be difficult to justify robotic automation because of the tendency to think 'one to one' — one robot for one machine or one robot to replace one operator. Instead, manufacturers should look at

### Applications and emerging technologies

#### Laboratory automation

Driven by the need for higher throughput and higher quality as well as to enable technically challenging processes, many labs in drug discovery and in vitro diagnostics that were not previously adopters of laboratory automation are being drawn to the potential of simple, small-scale, benchtop automation enabled by lightweight robotics. During the past decade, many vendors emerged that specialise in delivering complex automated solutions for large research labs, in some cases using hundreds of small robots that can perform the same task, the same way every time, for millions of cycles.

However, for each of these core labs there are hundreds of others potentially interested in more efficient ways to carry out routine tasks at a smaller scale.

Most of these potential automation opportunities do not require high throughput or involve processing thousands of assays per day. Nor does the average lab have the budget or the space to accommodate 'big automation'. For this group, lightweight robotics has been a revelation.

The types of benchtop automation most deployed to date are stand-alone automated pipettors or manually fed dispensers. In the future, we will see more automated workstations made up of multiple processing stations linked together by a plate mover/gripper.

#### Consumer electronics and small-scale assembly

Other industries are also experiencing a marked increase in the benchtop application of lightweight robotic systems. In the consumer electronics industry, tasks such as electronic printed circuit board (PCB) testing are ideal. A solution such as the Festo EXCM could be employed in a stacked configuration so that machine throughput could be significantly increased as seen in the PCB test station of Figure 1. The electrical values are verified using test probes as part of the product quality test process.

This solution can also be used in the tactile examination of touch displays and switches and to verify the presence of installed components on a PCB. With the continuing miniaturisation of products, positioning and aligning small screws prior to insertion can significantly affect productivity. Automation of such intricate tasks can result in a significant increase in throughput.

Other desktop automation tasks include dispensing in bonding, sealing and gasketing; coating applications for dispensing adhesives, sealants and lubricants; and filling electronic casings with resin. Such solutions can also easily integrate into machinery for hand-feeding components, transferring workpieces and positioning small parts. Additionally, they can be employed in contactless inspection systems to move a camera or laser probe consistently and smoothly over the material being checked.

#### Printed electronics

Today, semiautomatic or automatic screen printing machines are used for printing on mobile phone panels, membrane switches, LCD display boards, etc. Such automated solutions provide the



Figure 1: A lightweight gantry robot being used for PCB testing.

improved repeatability and speed required for high-volume production of miniature products. Other examples of printed electronics applications that use automated screen printing mainly involve the production of printed circuit boards, where a mask is applied to direct a metal circuit path (copper, silver or other) on a bare board with attached components, or in applications that require thick layers of materials, such as batteries/PV technology, membranes/touch panels, sensors and glucose test strips.

While screen printing has dominated most of the printed electronics applications to date, advanced industrial inkjet printers are emerging as an alternative technology, mainly in terms of cost, feature-size resolution and digital architecture. Inkjet printing is a digital imaging technology that creates an image by jetting droplets of ink onto a substrate. Inkjet printers are the most commonly used type of consumer printer, along with laser printers. Inkjet printing is particularly good for depositing small amounts of materials that have specific electrical or structural functionalities onto well-defined locations on a substrate. The materials deposited can be soluble liquids, dispersions of small (nanosized) particles, melts or blends.

The main advantages of inkjet printing are the ability to change what is printed without making a new printing plate and the ability to print variable digital patterns. As a result, inkjet printing can achieve excellent resolution and uses a wide range of ink types (conductive, hot melted wax, solder, biomaterials). It is receptive to on-the-fly error correction, uses small amounts of materials that involve little waste, can build up layers and is a clean, non-contact technology. The disadvantages include fairly slow throughput, sensitivity to substrate variations, problems with ink spreading, limited printing speeds and printhead/solvent compatibility.

#### 3D printing

Three-dimensional printed parts are now used for a multitude of applications, from medical devices (custom medical implants) to aircraft (weight reduction of parts, resulting in billions of dollars in fuel savings), toys and industrial manufacturing (metal 3D-printed injection moulds). Typically, a 3D printer starts with a few layers of disposable support material to provide a foundation. The extrusion head, which moves about an xy-plane, lays down a ribbon of material. After each layer is complete, the z-axis lowers slightly to make way for the next layer.

**Festo Pty Ltd**  
[www.festo.com.au](http://www.festo.com.au)

## MES SOFTWARE

The latest FactoryTalk VantagePoint software is claimed to give users a seamless way to access their Logix-based data by providing a simple, guided workflow to store and visualise information. To promote intelligent decision-making, the enhanced workflows enable authorised users to store and visualise specific data views and trends and to easily share these views with collaborators across the enterprise.

Additionally, the software will now silently install with FactoryTalk Historian SE software. Upon completion, the user will be greeted with a VantagePoint mobile webpage, including the latest import and configure options.

From any PC or tablet, a user can browse through the FactoryTalk Directory server to an online controller, select the tags from which they aim to collect associated data and configure scan rates and additional historian parameters. Once this process is complete, the selected tags are stored in the FactoryTalk Historian solution and automatically configured for the FactoryTalk VantagePoint software. By simultaneously configuring tags, a user within the VantagePoint mobile workflow makes a few simple selections in order to begin collecting data and creating dashboards and trends.

The update includes enhancements to the overall platform. The software now provides a vertical or horizontal bar chart, updated indicator widget, logarithmic trending, improved mobile navigation and Windows 10 support.

The software also offers SQL Server Express with install. This removes complex licensing options from the install process.

**Rockwell Automation Australia**  
[www.rockwellautomation.com.au](http://www.rockwellautomation.com.au)

## MINIATURE INDUCTIVE SENSORS

With an overall length of 12 mm, the IH03 and IM04 inductive miniature sensors from Sick have been developed for applications with minimal installation space. With fully integrated electronics, they do not need any external amplifiers.

The devices enable positioning tasks in application fields such as handling grippers, linear units and tool spindles. As well as being short, the sensors have good performance due to ASIC technology with a precise double-sensing range of up to 1 mm. They feature a high switching frequency of up to 8000 Hz, allowing the inductive miniature sensors to handle fast operating processes. The small sensors are also rugged due to their stainless steel housing. Integrated IO-Link communication simplifies sensor diagnostics, device swapping and identification.

**SICK Pty Ltd**  
[www.sick.com.au](http://www.sick.com.au)



# Fanless Computers

**Industrial HMI's, Panel PC's and Embedded Controllers.  
Rugged Fanless design, wide temperature range, vibration,  
shock, dust and liquid resistant.**



*HMI's and Panel PC's  
From 5.7" to 24" LCD Screens*

*Stainless Steel Fully Sealed  
Water-Proof Fanless Panel PC's*



*Fanless Embedded Controllers  
Including: Atom, i3/i5/i7 Processors*



**Interworld**  
ELECTRONICS  
Better systems. Better solutions

[www.ieci.com.au](http://www.ieci.com.au)  
Tel: 03 9593 7555

### BULK BAG FILLER

Flexicon's rear-post bulk bag filler features a Swing-Down fill head, which pivots to the operator at floor level for safe, ergonomic spout connections, and a low-profile loading deck that allows removal of filled bags using a pallet jack.

The cantilevered fill head pivots downward to a vertical orientation that places the inflatable bag spout seal, inflator button and four bag loop latches within arm's length of an operator standing on the plant floor, eliminating the need to climb steps, strain or risk injury associated with overhead connections to conventional fill heads.

Once the operator connects the bag straps and activates the inflatable bag spout collar, the filler automatically pivots the fill head to horizontal, inflates the bag to remove creases and activates a flow control inlet valve or feed conveyor. As load cells register the gain in weight, the controller raises and vibrates the loading deck at programmed intervals to densify material and promote flow into the bottom corners of the bag. Once the bag reaches its target weight, the controller automatically stops the flow of incoming material, deflates the bag spout collar and releases the bag straps, allowing the filled bag to be removed using a pallet jack or forklift. A patented mechanism automatically resets the latch after releasing the bag loops and repositions it as the fill head pivots into a vertical position, enabling the latch to receive bag loops inserted by an operator and to relatch automatically.

**Flexicon Corporation (Aust) Pty Ltd**  
[www.flexicon.com.au](http://www.flexicon.com.au)

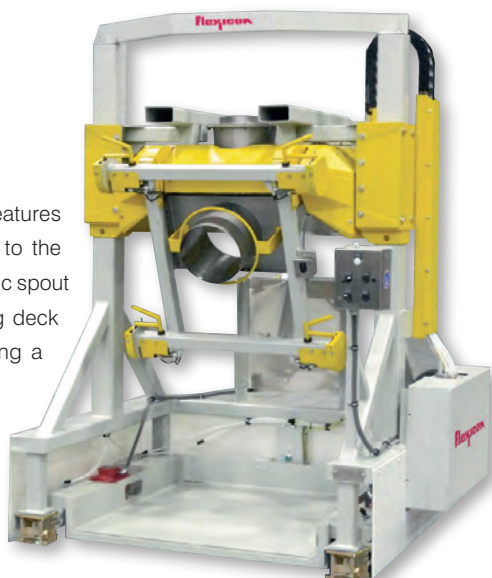

### PROCESS METER

The handheld Fluke 789 is a process meter with mA source. This test tool offers standard multimeter functions with a 2–20 mA sink and source capability. It also includes simultaneous mA and percentage of scale readout (on mA output) with a 25% manual step and 0.1% VDC accuracy. It is available to rent from TechRentals.



The meter provides a current output and is useful for measuring electrical parameters, supplying steady or ramping currents, and for measuring input impedance, ranges and diodes. It provides a 24 V loop power supply and a HART mode setting with loop power (adding a 250Ω resistor).

The double-sized, dual display and backlight makes readings easy, and 0–100% mA span check buttons toggle between 4 and 20 mA.

**TechRentals**  
[www.techrentals.com.au](http://www.techrentals.com.au)

## CONTROLBOX

Ethernet Switches • Remote Access Routers  
 Operator Panels • Power Supplies • Variable Frequency Drives  
 SIM Cards and Data Plans • Programmable Logic Controllers



Shop for these products online

<http://controlbox.net.au>





# COMMS 2016 CONNECT

Events for critical communications  
users and industry



Sydney 22-23 June 2016 | Sydney Showground

## Confirmed speakers include:



**STATION OFFICER  
GRAHAM TAIT**  
Operational  
Communications  
Systems Officer  
FIRE & RESCUE NSW



**ASHLEY MARSHALL**  
National Business  
Development Director  
BAI  
COMMUNICATIONS



**MARK LONEY**  
Executive Manager,  
Operations, Services &  
Technologies Branch  
ACMA



**BIDAR HOMSEY**  
Principal Consultant,  
Public Safety &  
Security, Global  
Industry & Society  
ERICSSON



**ROSS SPEARMAN**  
CTO  
TAIT  
COMMUNICATIONS

**PLUS**

An exhibition with dozens of local and international manufacturers and distributors will have their experts on hand to help you find the solutions you're looking for.

Early bird  
registration  
closes  
13 May

Digital Partner



Platinum Sponsors



Delegate Bag Sponsor



Gold Sponsors



Magazine Partner



Supporting associations & media organisations



Association Partner



**In conjunction with the ARCIA Industry Gala Dinner  
— 22 June 2016 — Novotel, Sydney Olympic Park**

Visit [www.arcia.org.au](http://www.arcia.org.au) to book your tickets

Interested in exhibiting or sponsoring?  
**Contact Paul or Narelle on +61 2 9487 2700**

[www.comms-connect.com.au](http://www.comms-connect.com.au)

follow us on





## CYBERSECURITY NEEDS FOCUS IN A CONNECTED WORLD

A colleague of mine was checking his watch intermittently the other day. When I asked why he was watching the time so closely, he responded: "I'm not; I'm just checking my texts." The fact that I assumed he was checking the time is an example of how technology is now evolving faster than perceptions. That watch may well contain much more information than just the time and SMS, but also emails, fitness stats and more. Masses of data taken from multiple sources, turned into information and communicated — more evidence of just how connected the world has become.

With increased connectivity, however, comes increased risk. Most of us are aware of a need for some level of IT cybersecurity, but now, more than ever, the challenge lies in protecting the OT (operational technology) layer.

In the report 'Cybersecurity Survey: Major Australian Businesses' (CERT Australia and the Australian Cyber Security Centre, 2015), it was found that 51% of Australian businesses have experienced incidents in the past 12 months and 5% have had more than 10 incidents. And this is only what was reported. In 2014, CERT Australia responded to 11,073 cybersecurity incidents affecting Australian businesses, 153 of which involved systems of national interest, critical infrastructure and government.

There is a lot of good work being done to help protect these businesses, but most of the dialogue is still about protection of information — a traditional IT approach. In the industrial space, however, there are further considerations. In key critical infrastructure it could be conceived that operational uptime should be prioritised over information security. For example, security checks that delay an email 15 minutes might not be a big deal, but issues with the infrastructure of water or electrical providers can leave entire suburbs without lights and running water.

For this reason, having a consistent standardised approach to cybersecurity and OT is essential. Connected devices in the industrial space have been around for decades and

many of these systems may have originally been designed on the incorrect assumption they would never be connected to a wider network. Now the number of connections has exploded and organisations must be committed to going back and redoing risk assessments and safety audits to ensure effective security.

To ensure a resilient and robust system, it should be mandated that any controller of IP-enabled devices on a critical control system meets a certain cybersecure standard for embedded devices. More importantly, it should be expected that the processes and procedures used to develop these devices adhere to robust ongoing maintenance and that cybersecurity is considered throughout the life cycle. The architectures should be designed by appropriately accredited engineers and the systems should be deployed using appropriate cybersecure methodologies. Most importantly, there needs to be ongoing protection through regular awareness and assessments based on current knowledge of the landscape and all of this needs to happen whilst your systems keep running.

The automation space is evolving at a rapid rate. To ensure a safe and truly cybersecure Australia, we must evolve our industrial automation business practices at an equivalent rate. We need to understand the new normal in order to detect the abnormal and continue to build and operate resilient systems. This will ensure the lights stay on and the taps keep running while you're comfortably reading those texts on your smart watch.



*Bradley Yager has been implementing industrial automation solutions for over 17 years. He is now using this knowledge and experience to steer Schneider Electric's process automation solutions as Director of Offer Management and Business Development for the Pacific region.*



A.B.N. 22 152 305 336

### Head Office

Cnr. Fox Valley Road & Kiggle Street,  
(Locked Bag 1289)

Wahroonga NSW 2076  
AUSTRALIA

ph: +61 2 9487 2700 fx: +61 2 9489 1265  
www.westwick-farrow.com.au

### Editor

Glenn Johnson  
wnipt@westwick-farrow.com.au

### Chief Editor

Janette Woodhouse

### Publisher

Geoff Hird

### Art Director/Production Manager

Julie Wright

### Art/Production

Tanya Barac, Colleen Sam

### Circulation Manager

Lora Tomova  
circulation@westwick-farrow.com.au

### Copy Control

Mitchie Mullins  
copy@westwick-farrow.com.au

### Brand Manager Industrial

Nicola Fender-Fox

### Advertising Sales

#### VIC

Sandra Romanin – 0414 558 464  
sromanin@westwick-farrow.com.au

#### SA/WA/Asia

Lachlan Rainey - 0402 157 167  
lrainey@westwick-farrow.com.au

#### QLD/NSW

Nicola Fender-Fox - 0414 703 780  
Nfender-fox@westwick-farrow.com.au

### Subscriptions

For unregistered readers price on application.

If you have any queries regarding our privacy

policy please email

privacy@westwick-farrow.com.au



September 2015 total CAB audited circulation (Aust + NZ)  
6,095 readers (69% personally requested)



Contact the editor

Printed and bound by SOS Print+ Media Group  
Print Post Approved PP100007403  
ISSN No. 0819-5447

*All material published in this magazine is published in good faith and every care is taken to accurately relay information provided to us. Readers are advised by the publishers to ensure that all necessary safety devices and precautions are installed and safe working procedures adopted before the use of any equipment found or purchased through the information we provide. Further, all performance criteria was provided by the representative company concerned and any dispute should be referred to them.*

*Information indicating that products are made in Australia or New Zealand is supplied by the source company. Westwick Farrow P/L does not quantify the amount of local content or the accuracy of the statement made by the source.*



# REGISTER TODAY FOR YOUR

# FREE SUBSCRIPTION

If you live in Australia or New Zealand<sup>†</sup> and your job title matches those on this form, we will deliver you 11 complimentary issues a year!

## FOUR QUICK WAYS TO REGISTER

- + WWW.PROCESSONLINE.COM.AU/SUBSCRIBE
- + EMAIL CIRCULATION@WESTWICK-FARROW.COM.AU
- + FAX THIS COMPLETED FORM TO (02) 9489 1265
- + MAIL THIS COMPLETED FORM TO LOCKED BAG 1289 WAHROONGA NSW 2076

Wrapper number:  
(if known)

--	--	--	--	--	--	--	--

\*All fields required to subscribe to your FREE magazine

NAME\* \_\_\_\_\_

JOB TITLE\* \_\_\_\_\_

ORGANISATION NAME\* \_\_\_\_\_

ADDRESS\* \_\_\_\_\_

POSTCODE\* \_\_\_\_\_ COUNTRY\* \_\_\_\_\_

PHONE CONTACT\* WORK \_\_\_\_\_ MOBILE \_\_\_\_\_

EMAIL\* \_\_\_\_\_

SIGNATURE\* \_\_\_\_\_ DATE\* \_\_\_\_\_

TO COMPLETE YOUR FREE SUBSCRIPTION PLEASE TICK ONE BOX ONLY IN EACH OF THE THREE SECTIONS TO THE RIGHT ➤

PRIVACY POLICY AVAILABLE ONLINE AT [WWW.PROCESSONLINE.COM.AU/PRIVACY](http://WWW.PROCESSONLINE.COM.AU/PRIVACY)

## OPTIONS

I WOULD LIKE TO RECEIVE THIS MAGAZINE  DIGITAL  PRINT  BOTH

ALL MAGAZINE SUBSCRIBERS RECEIVE A COMPLIMENTARY ENEWSLETTER SUBSCRIPTION

## JOB FUNCTION

(please tick one only)

- Management - Director/C-level
- Management - Specialist
- Analyst
- Business Owner
- Comms Tech/Engineer
- Consultant
- Contractor/Tradesperson
- Education/Training
- Engineer - Electrical
- Engineer - Electronics
- Engineer - Process
- Engineer - Project
- OHS/EHS
- Purchasing/Procurement
- Quality Assurance
- R&D/Product development
- Sales/Marketing
- Student-Undergraduate/Apprentice
- Technical Officer
- Technician - IT
- Technician - Maintenance/Service

## INDUSTRY

(please tick one only)

- Agriculture/Rural
- Biotech
- Building/Construction
- Chemicals/Allied Products
- Communications Systems
- Consulting/Contracting
- Defence/Military
- Education/Training
- Electrical
- Engineering Services
- Environmental Services
- Finance/Banking/Insurance/Legal
- Food - Bakery
- Food - Beverages
- Food - Confectionary
- Food - Dairy
- Food - Fruit & Vegetables
- Food - Meat
- Government
- Health/Medical
- Information Technology
- Instrumentalities (eg CSIRO)
- Laboratory - Analytical
- Laboratory - Clinical/Medical
- Laboratory - Life Sciences
- Logistics/Transport/Warehouse
- Manufacturing
- Mining
- Oil/Gas/Coal
- Packaging
- Pharma/BioPharma
- Processing
- Retail/Wholesale/Hire
- Safety/Hygiene
- Service/Maintenance
- Testing/Certification (eg NATA)
- Utilities

## COMPANY SIZE

(please tick one only)

- Under 100
- 100 - 250
- 251 - 500
- Over 500

<sup>†</sup> For industry professionals outside Australia or New Zealand, the digital magazine and eNewsletters are available FREE of charge. If you would like the print magazine, contact [circulation@westwick-farrow.com.au](mailto:circulation@westwick-farrow.com.au) for subscription prices in your region.

# arbs 2016

17-19 May 2016 MELBOURNE CONVENTION & EXHIBITION CENTRE

air conditioning, refrigeration & building services exhibition



## PEOPLE - PRODUCTS - NETWORKING WE CONNECT YOUR INDUSTRY

The largest international HVAC & R and Building Services trade exhibition ever held in Melbourne

- ❄ hundreds of national & international manufacturers & suppliers
- ❄ cutting-edge products & technologies, informative seminars & tech talks
- ❄ the ultimate networking event

Register **NOW** at [arbs.com.au](http://arbs.com.au)



SEMINAR  
REGISTRATION  
OPEN!