

Introducing **OpenManipulator** : Build your own manipulator

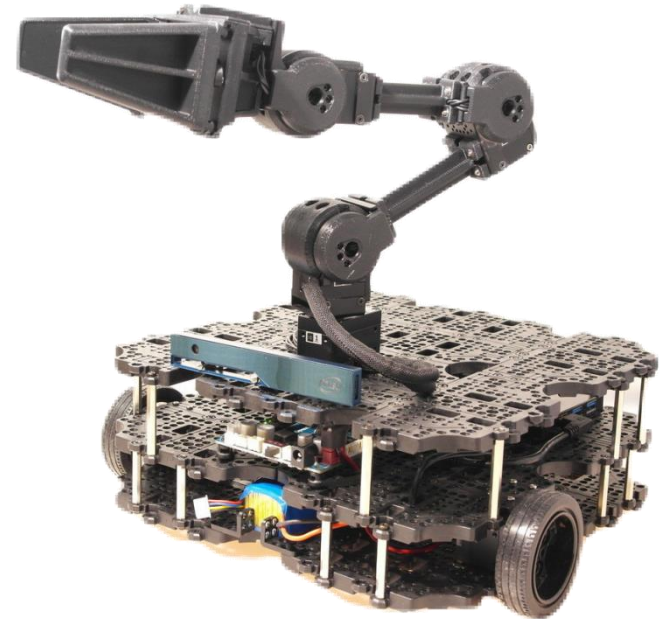



© Moviestore/Rex Shutterstock

ROBOTIS

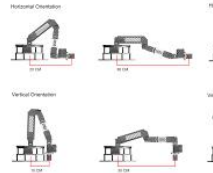
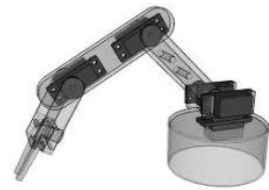

ROBOTIS



ROBOTIS

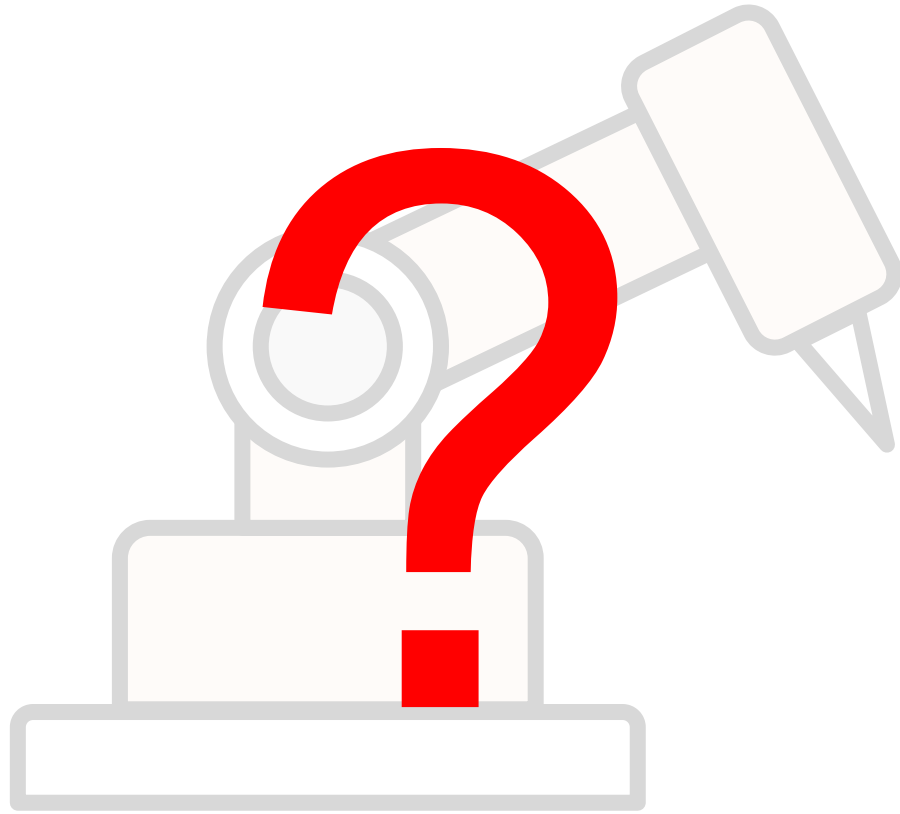

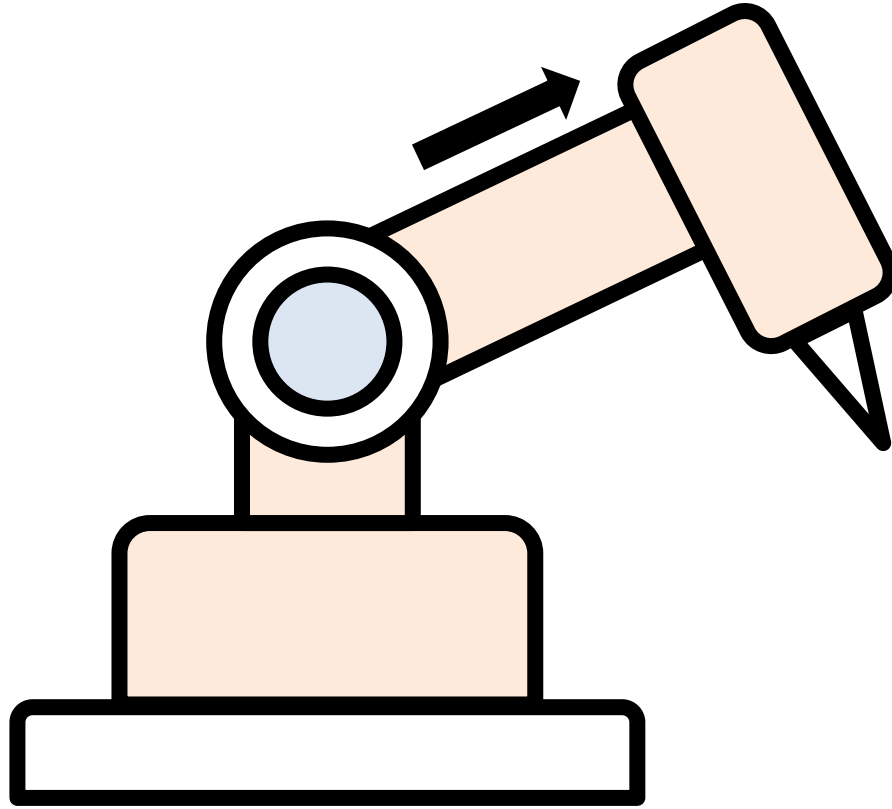

- Customization

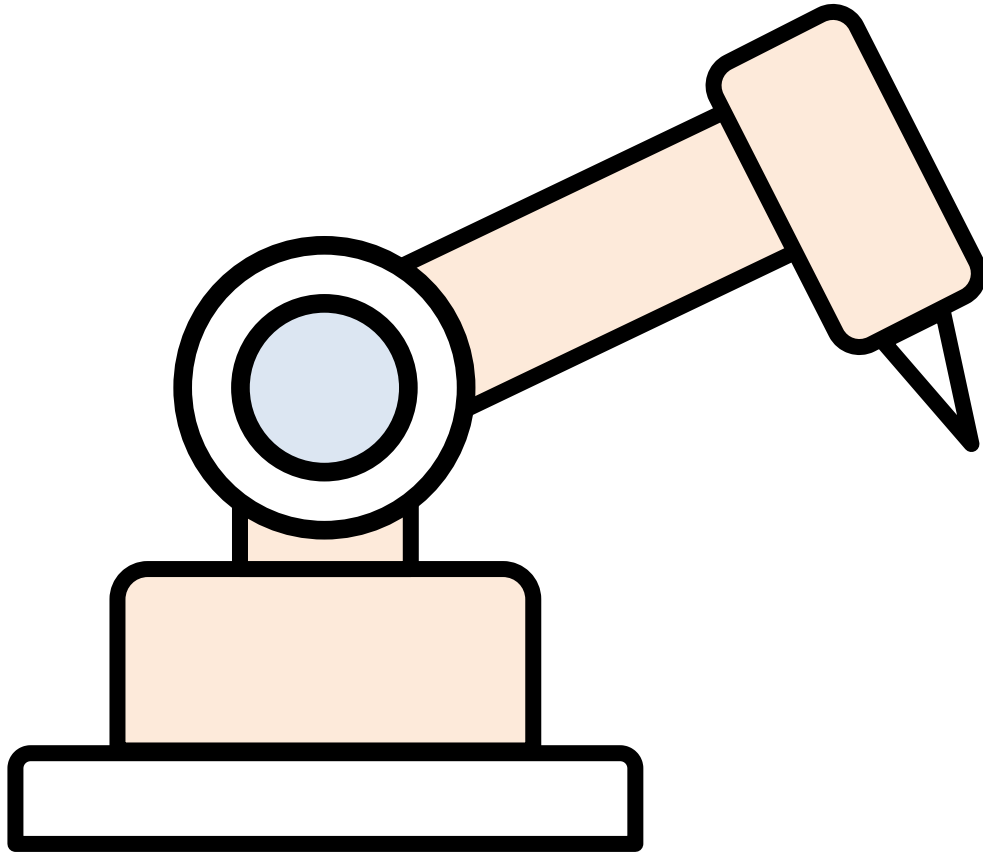

- Customization
- Extensibility

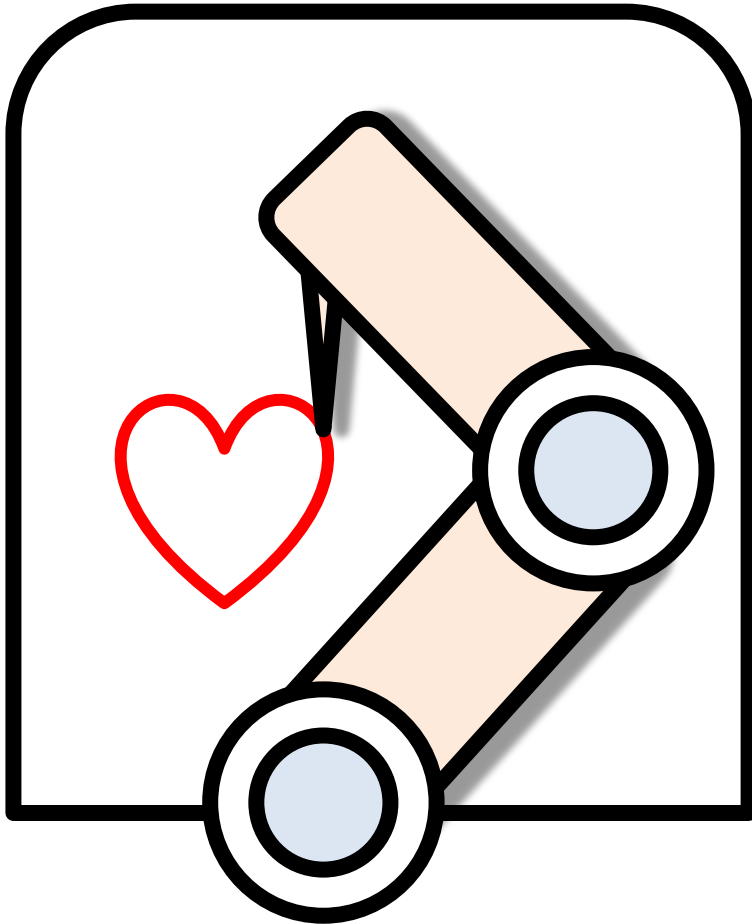

- Customization
- Extensibility

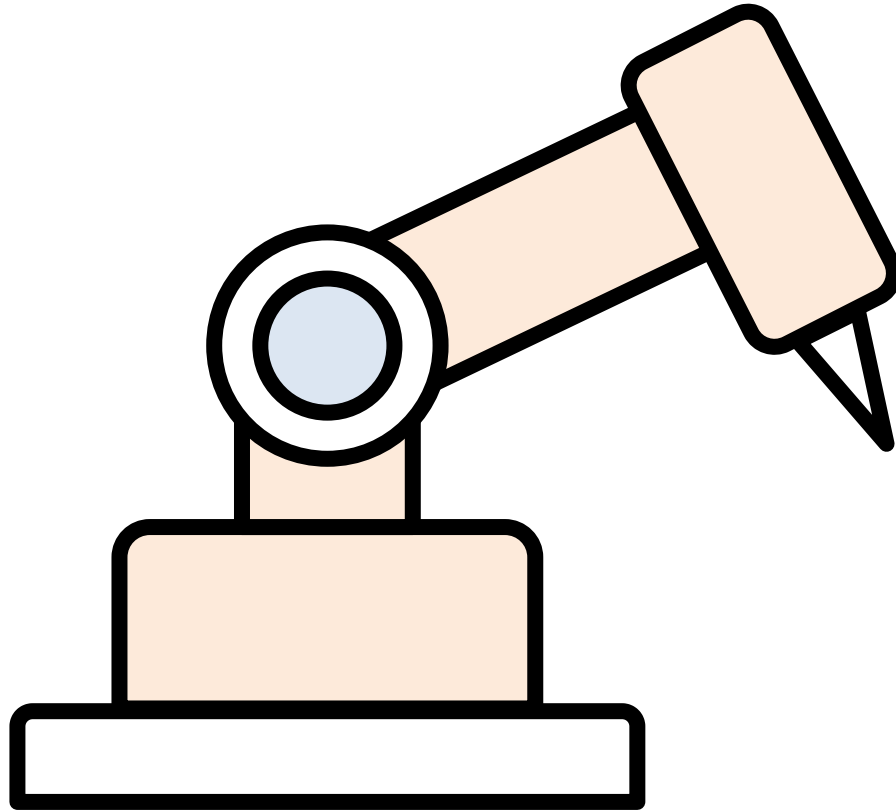

- Customization
- Extensibility
- Open-source

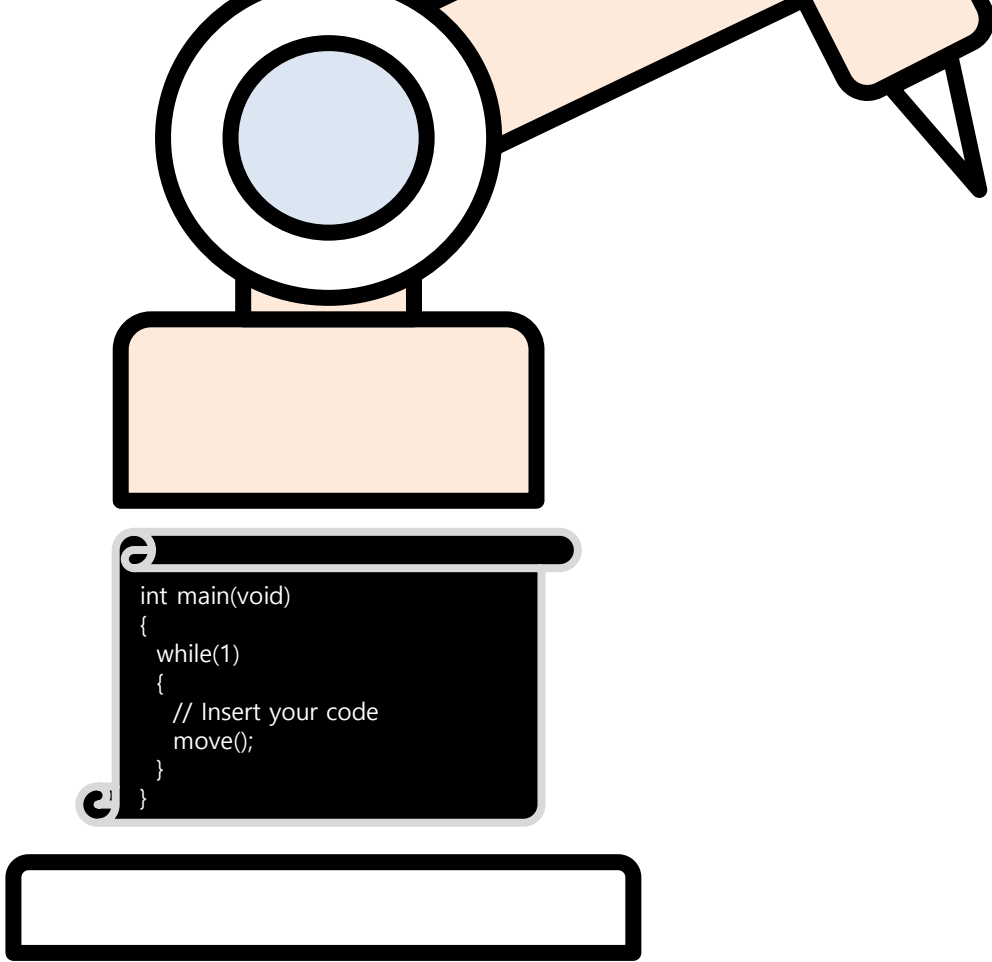

- Customization
- Extensibility
- Open-source



OpenManipulator

3D printed parts

Aluminium frames

ROS

Dynamixel





Customization

Onshape **ROBOTIS OpenManipulator Chain** Main 0 9 4 [App Store](#) [Share](#) ROBOTIS OpenSourceTeam

Instances (8)

- Origin
- > MPX-ASM01-JOI...
- > MPX-ASM24-JOI...
- > MPX-ASM26-JOI...
- > MPX-ASM27-JOI...
- > NEW_GRIPPER_A...
- ↳ LINK_LONG <1>
- ↳ LINK_SHORT <1>
- ↳ 170621...

▼ Mate Features (0)

+ NEW_CHAIN_ASSY_ASM Parts Assy's



Customization



Dynamixel XL

Affordable Prices

Dynamixel XM

High Torque

Dynamixel XH

More Durability



Extensibility

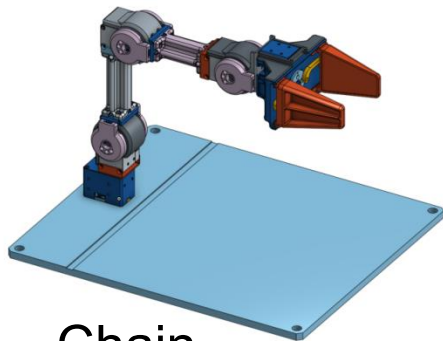

Chain

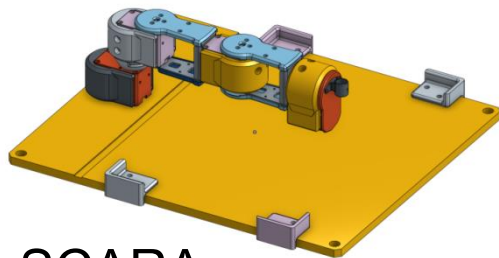

SCARA

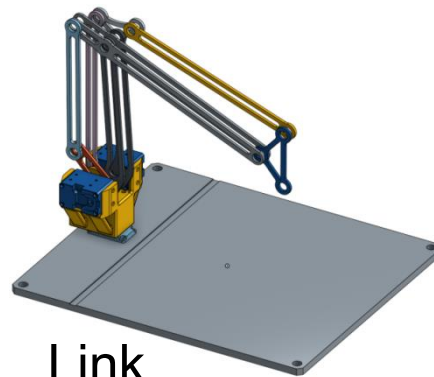

Link

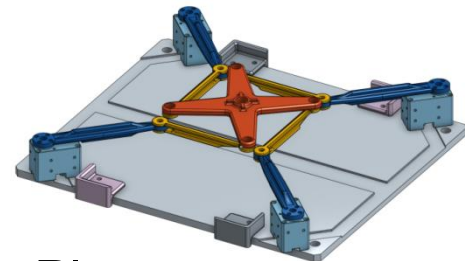

Planar

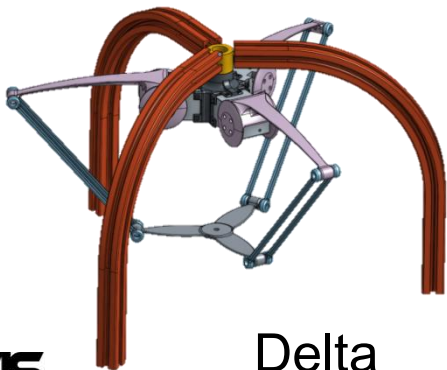

Delta

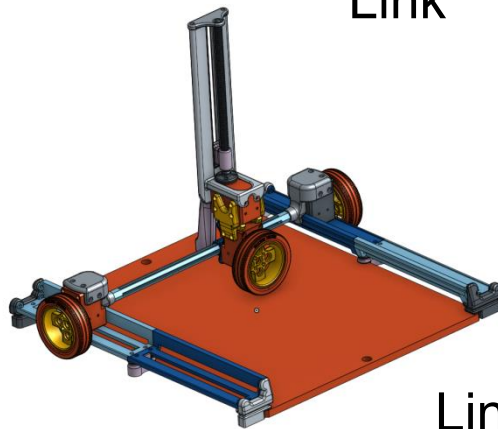

Linear

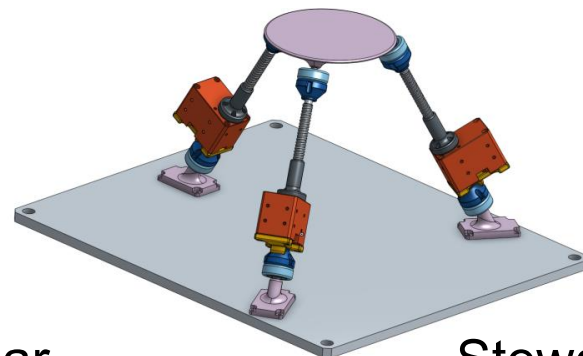

Stewart



Robot Operating System

Gazebo

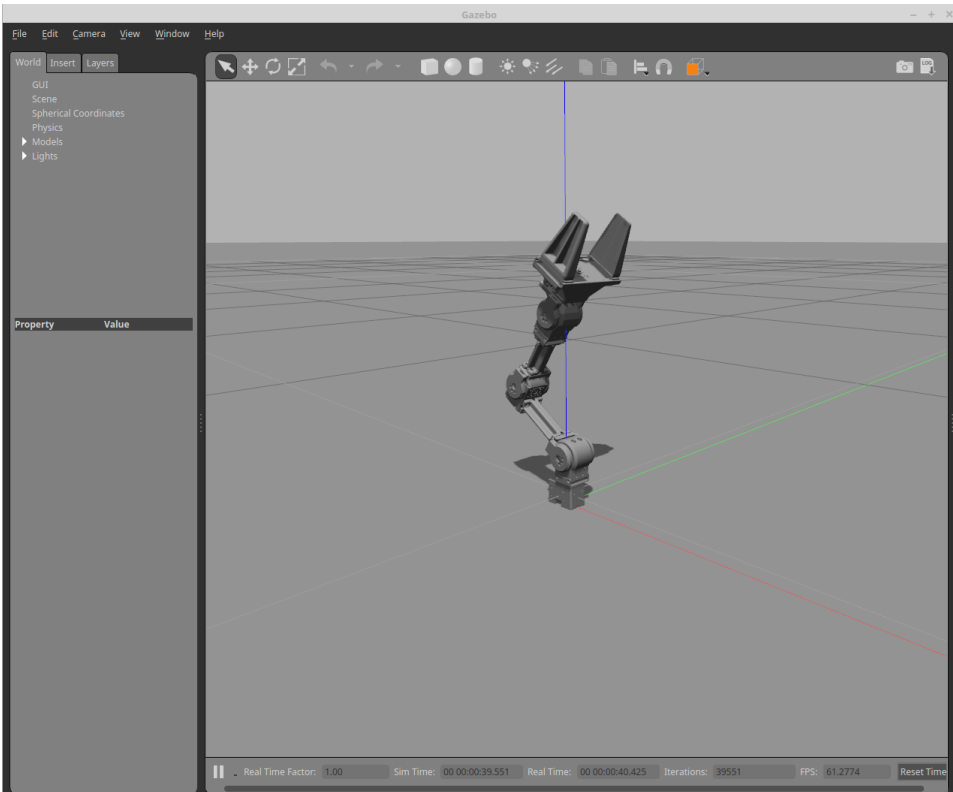

Movelt!

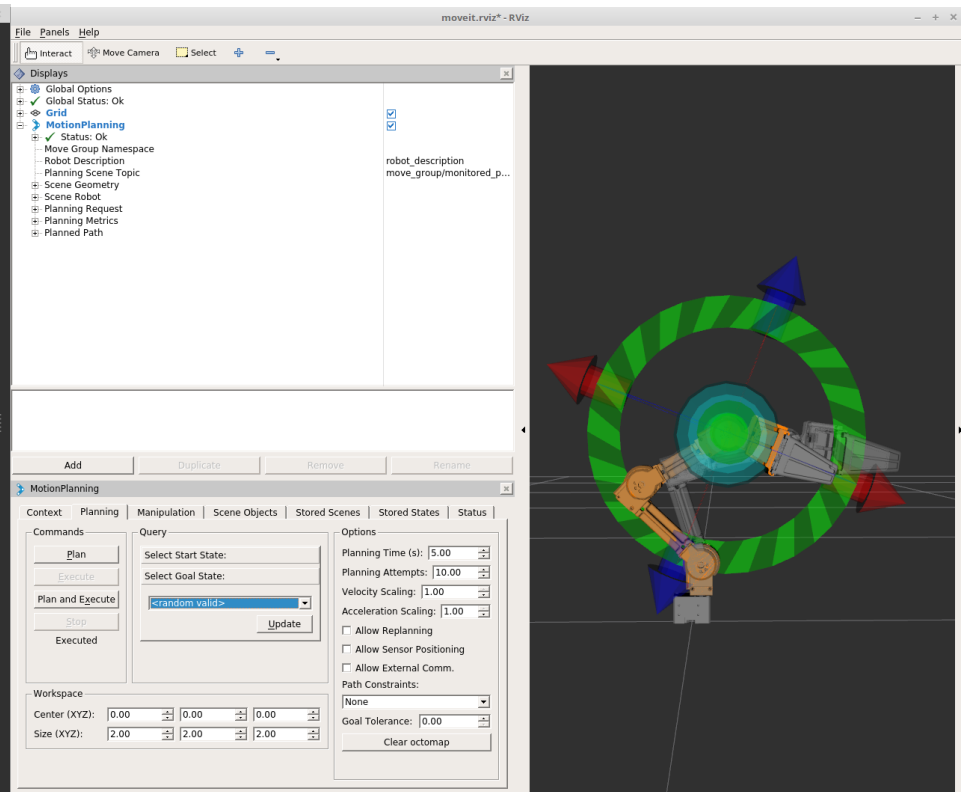



ROS



Embedded system

Arduino for control

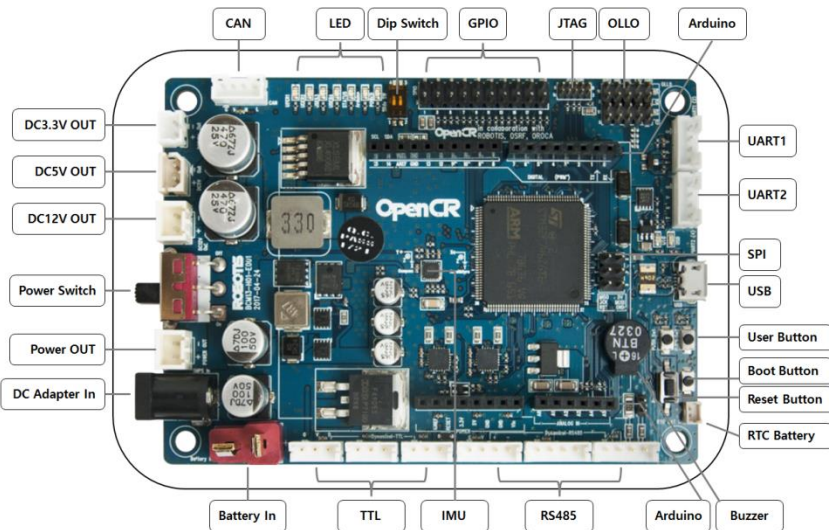

Open-source Control
module for ROS

Processing for visualization

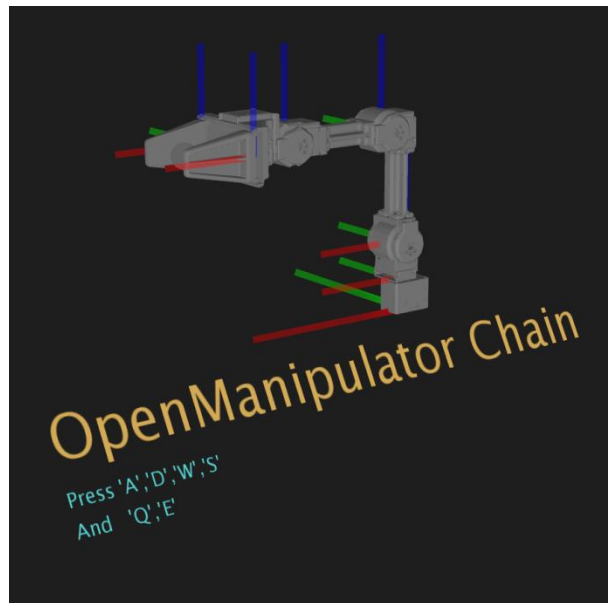

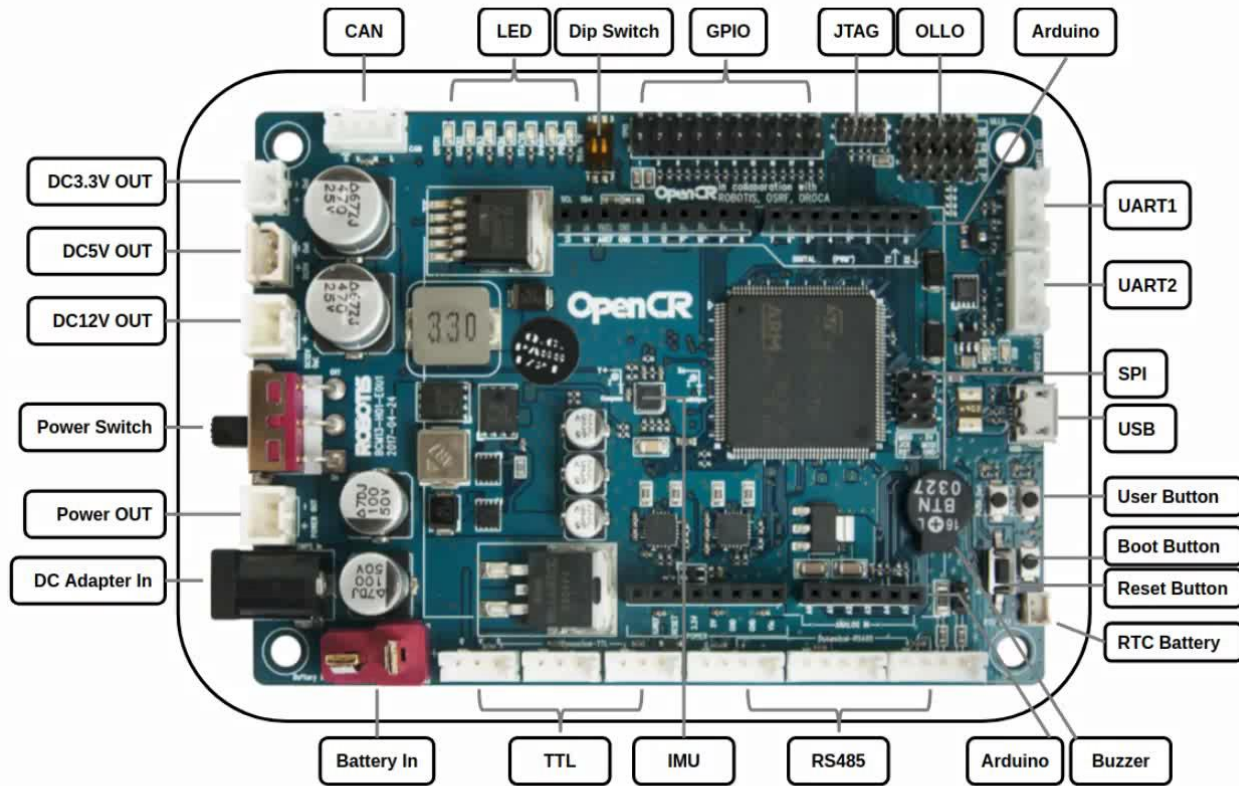

OpenCR



Mobile manipulator

Current based
position control

Position control

Velocity control

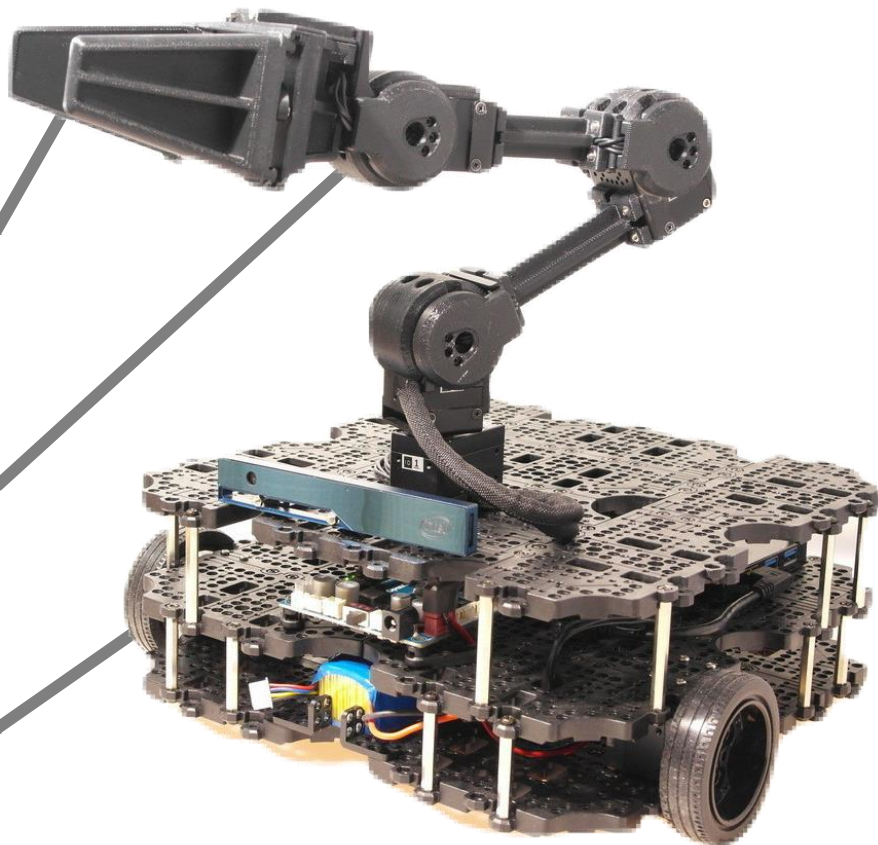

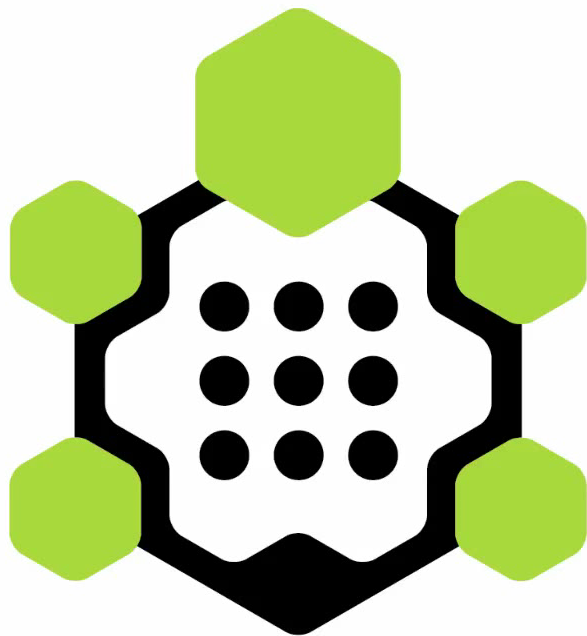

TURTLEBOT3



Full Open-source

Open-source Hardware

- ◆ CAD Data : OnShape (Search “ROBOTIS”)
 - Chain : <https://goo.gl/NsqjMu>
 - SCARA : <https://goo.gl/oVsK8m>
 - Link : <https://goo.gl/MJ6C8K>

And more coming soon!!

Open-source Software

- ◆ Firmware & ROS package : Github (Search “ROBOTIS-GIT”)
 - OpenManipulator : https://github.com/ROBOTIS-GIT/open_manipulator
 - OpenCR : <https://github.com/ROBOTIS-GIT/OpenCR>

Your contribution is welcome!!

Build your **own** manipulator With **OpenManipulator**

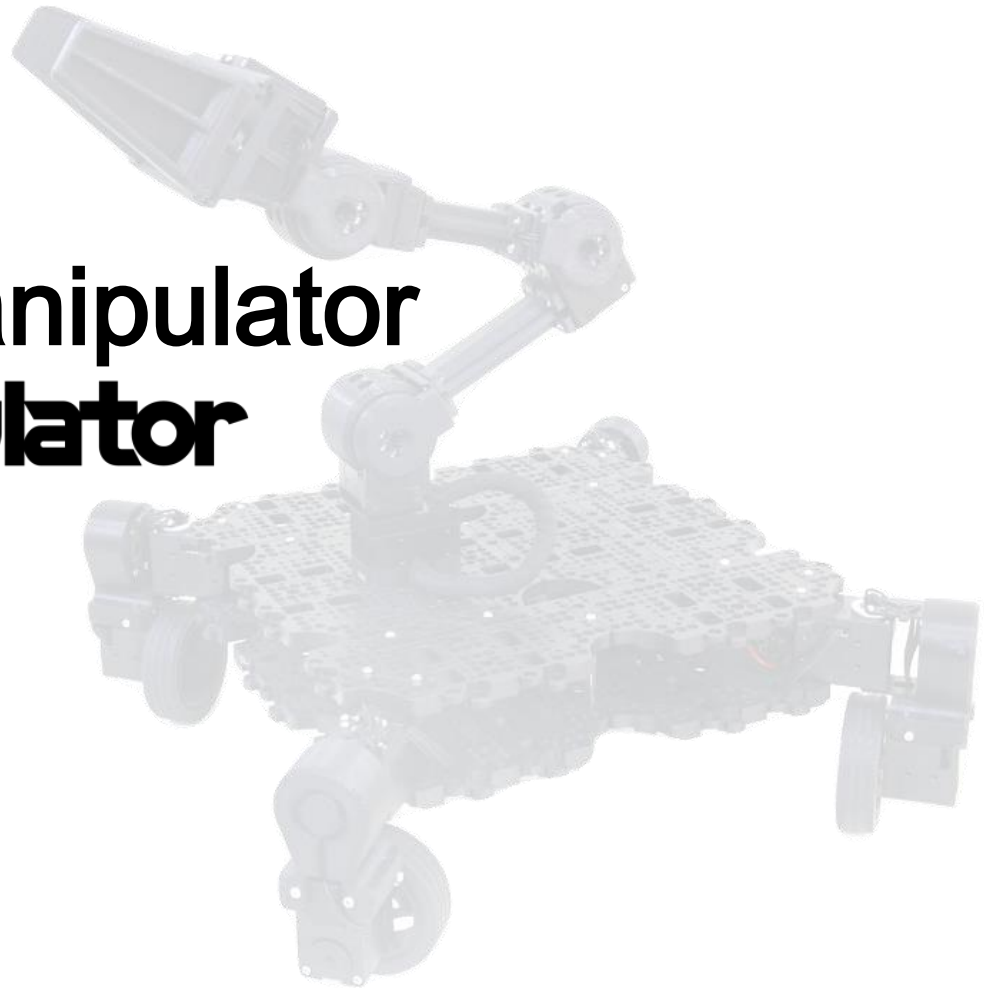



YoonSeok Pyo

ROBOTIS
Open Source Team
Senior Researcher

pyo@robotis.com



RyuWoon Jung

ROBOTIS
Open Source Team
Researcher

rwjung@robotis.com



TaeHoon Lim

ROBOTIS
Open Source Team
Researcher

thlim@robotis.com