

GRIP-TIE

Mechanical repair anchors for stabilizing existing facades

We help you get a grip on your facade problems! Add high-strength mechanical anchors to an existing brick facade to fortify and stabilize against external forces. PROSOCO Grip-Ties are an excellent solution to re-anchor a masonry or stone facade to metal or wood stud, structural steel, tile, block, concrete, and brick.



TORQUE-ACTIVATED GRIPPING ACTION



NO EXPOSED HARDWARE



CORROSION-RESISTANT



NO DISTURBING HAMMERING ACTIVITY



EASY POST-INSTALL QUALITY CONTROL



SECURES VARIETY OF WALL MAKEUPS

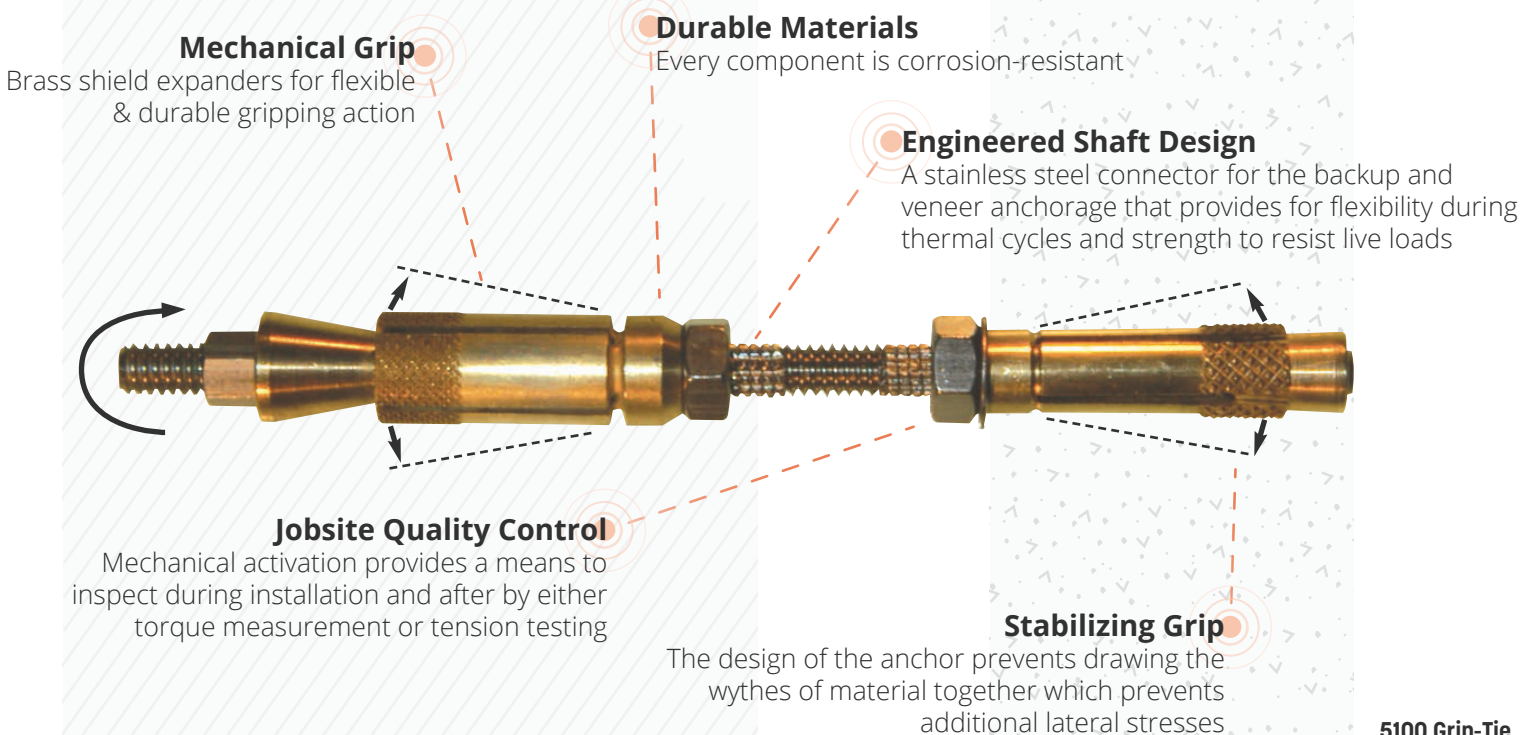

5100 Grip-Tie shown here

GRIP-TIE

Mechanical Repair Anchors for Stabilizing Existing Facades

Product Line Description

Typically, masonry facades are intended to resist wind loads. In lieu of tear-down or replacement, an existing facade can be fortified by the addition of mechanical anchors. The Grip-Tie anchors provide additional facade stability, which may be needed to fulfill a myriad of requirements. The Grip-Tie selection process evolves by evaluating the type of anchors one can use to satisfy the repair (compatibility) and strengthening criteria. Also, one cannot ignore the means and methods of installation which can also influence the remedial anchor choice.

Post-installed Grip-Tie repair anchors are available to accomplish the task. When dealing with a repair situation, the as-built material quality and current building conditions are often unknown. It is therefore not uncommon that installation criteria and performance qualification be obtained via field tests in order to confirm design assumptions. The Grip-Tie mechanical repair anchors consist of a dual corrosion resistant brass expansion anchor for a mechanical connection that grips the backup and veneer which is then bridged with a stainless threaded shaft. The Grip-Tie anchor creates formidable gripping strength to the base material to which it is attached. The anchor does not draw walls together, thereby eliminating additional tension stresses between wythes of material. The backup material can be concrete, metal stud, wood stud, CMU (hollow or grouted), structural steel, or brick. The veneer can be brick, stone, or precast. The Grip-Tie anchor assembly is manufactured from corrosion-resistant materials which will contribute to the facade's long-term durability and design life. The Grip-Tie anchorage system has been designed to accommodate easy installation via hand tools or power tools. Combining the strength, generous spacing, and affordable installation technique, the Grip-Tie mechanical repair anchor product line is a value-reward choice for facade re-anchoring.

Grip-Tie Selection Guide

The following application descriptions will provide a quick Grip-Tie Repair Anchor Guideline when determining the appropriate series tie for veneers greater than 3" thick:

- Solid backup conditions – refer to the 5000 or 5000R Series Anchors
- Hollow backup conditions – refer to the 5100 Series Anchors
- Structural steel backup conditions – refer to the 5200 Series Anchors
- Stud (wood or steel) backup conditions – refer to the 5300R Series Anchors

Anchor Spacing

It is recommended to first check with local building codes for spacing condition requirements for proper masonry tie spacing. Typically, the Grip-Tie is spaced at one tie per four square feet of veneer for masonry or concrete backup conditions. For metal or wood stud backup, a 16" horizontal by 24" vertical is common spacing. Consult with local design professionals to establish wind load criteria for all scenarios.

Performance

Each construction site is unique and the appropriate use of this product is the responsibility of the engineers, architects, and other professionals who are familiar with the specific requirements of the project. The data reflects results of lab, field, and in-house tests which are provided as a guideline for the designer. Site testing is encouraged for verification of load capacity.

GRIP-TIE APPLICATIONS

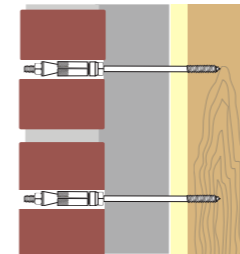

Re-anchoring brick facade to wood stud backup

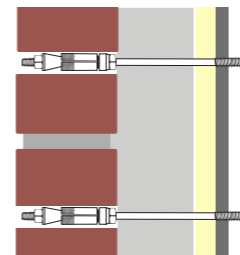

Re-anchoring brick facade to metal stud backup

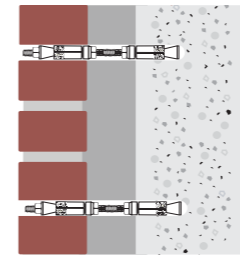

Brick veneer cavity walls with

- Insufficient or corroded ties
- Concrete or hollow backup
- Wind-load fortification

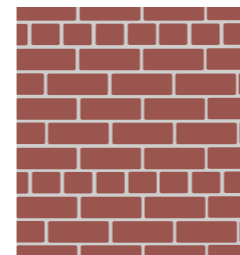

Composite walls where header brick has failed

- Soft brick or mortar
- Deep-reaching multi-wythe connections

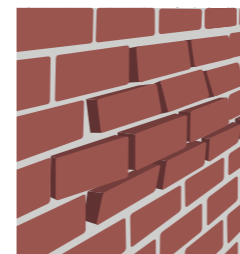

Peripheral areas around bulges in walls or areas to be removed

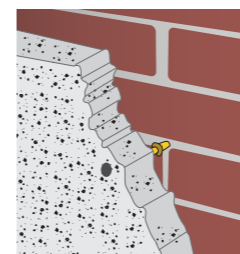

Non-brick facades such as

- Limestone
- Granite
- Precast

TENSION CAPACITIES WITH VARIOUS BACKUP MATERIAL

TENSION/COMPRESSION CAPACITIES WITH VARIOUS VENEERS

Backup Material
Ultimate Tension Capacity (lbs)

METAL STUD		WOOD				
16 Gauge	18 Gauge	2 x 4	4 x 4	1/2" Plywood	7/16" OSB	1" Sheathing
835	500	900	1200	475	320	800





Anchor Series	Backup
	OR STEEL WOOD

Typical Grip-Tie Shaft Properties
Ultimate Shaft Buckling Strength

Shaft Length (in)	Unsupported Length (in)	Capacity (lb)*
5 1/2"	1-3/8"	1633
6 1/2"	2-3/8"	1554
7 1/2"	3-3/8"	1441
8 1/2"	4-3/8"	1301
12"	7-7/8"	740
16"	11-7/8"	367

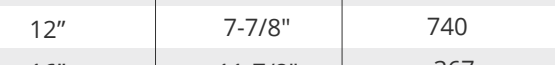
*Note: The shafts are Type 304 SS, and the values are calculated analytically with PROSOCO's minimum required $F_y = 60$ ksi, an assumed values of $E = 27600$ ksi, $K=0.65$ for the column buckling behavior, and an applied factor of $\phi_c = 0.9$.

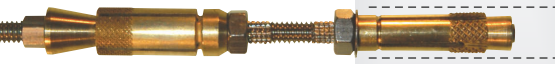



Ultimate Tension Capacity (lbs)								
LIGHTWEIGHT CMU	NORMAL WEIGHT CMU	CONCRETE	SOLID BRICK	CLAY TILE	STRUCTURAL STEEL	GROUTED CMU	SOFT BRICK	CINDER BLOCK

Anchor Series									Veneer Material Ultimate Tension Capacity (lbs)													
									MORTAR JOINT		BRICK		PRECAST	LIMESTONE		GRANITE						
									Soft	Hard	Soft	Hard		TENSION	COMPRESSION	TENSION	COMPRESSION					
 5300R SERIES									TENSION	COMPRESSION	TENSION	COMPRESSION	TENSION	COMPRESSION	TENSION	COMPRESSION	TENSION	COMPRESSION				
 5000R SERIES									900	800	1600	800	1200	1500	1500	1500	1500	1500	1200	1500	1200	
 5000 SERIES									900	800	1600	800	1200	1500	1700	1700	2000	1500	2000	1200	2000	1200
 5100 SERIES									900	800	1600	1300	1500	1500	1700	1700	2000	1500	2000	1200	2000	1200
 5100 SERIES									900	800	1600	1300	1500	1500	1700	1700	2000	1500	2000	1200	2000	1200
 5200 SERIES									900	800	1600	1300	1500	1500	1700	1700	2000	1500	2000	1200	2000	1200

Anchor Series

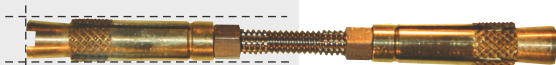
VENEER

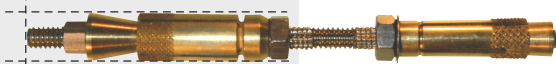
TENSION ← SET BACK 3/8"~5/8" → COMPRESSION

Anchor Series		MORTAR JOINT		BRICK		PRECAST	LIMESTONE		GRANITE	
		Soft	Hard	Soft	Hard		TENSION	COMPRESSION	TENSION	COMPRESSION
3/8" Hole Site		900	800	1600	800	1200	1500	1500	1500	1200
3/8" Hole Site		900	800	1600	800	1200	1500	1500	1500	1200
1/2" Hole Site		900	800	1600	1300	1500	1700	1700	2000	1200
1/2" Hole Site		900	800	1600	1300	1500	1700	1700	2000	1200
1/2" Hole Site		900	800	1600	1300	1500	1700	1700	2000	1200

5300R SERIES

5000R SERIES

5000 SERIES

5100 SERIES

5200 SERIES

ULTIMATE INWARD LOAD CAPACITY OF SPACER IS 730 LB

INSTALLATION

5000 SERIES ANCHOR

Installation procedure and criteria for solid backup

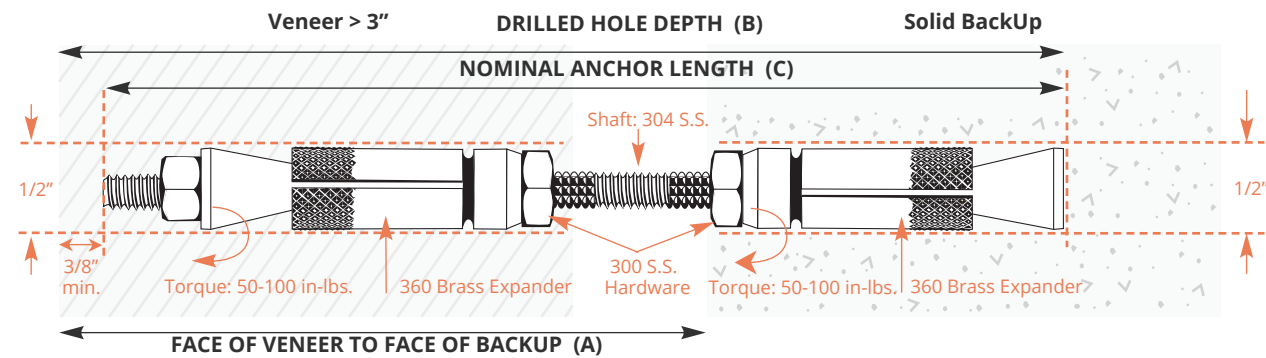

1. Select proper anchor length based on face of veneer to face of backup (dimension A).
2. Drill appropriate hole at "TEE" joint location to depth "B".
3. Blow out drill fines.
4. Assemble threaded portion of complete anchor assembly to the Grip-Tie 501 Setting Tool (Hex bolt on tool MUST be seated) thread shaft into tool until it stops.
5. Insert entire assembly into drilled hole until it bottoms, tighten 50 - 100 in-lbs, remove setting tool (Loosen bolt head on tool while holding tool firmly, spin tool from anchor).
6. Slide socket and adaptor onto the square drive of the 501 Tool, and onto the 5/16 hex nut of the installed anchor, tighten 50-100 in-lbs.
7. Remove socket and plug hole.

Catalog #	A	B	C
62200-550	4 - 5"	6	5 1/2"
62200-650	4 - 6"	7	6 1/2"
62200-750	4 - 7"	8	7 1/2"
62200-850	4 - 8"	9	8 1/2"

Other lengths available upon request

5000R SERIES ANCHOR

Installation procedure and criteria for solid backup

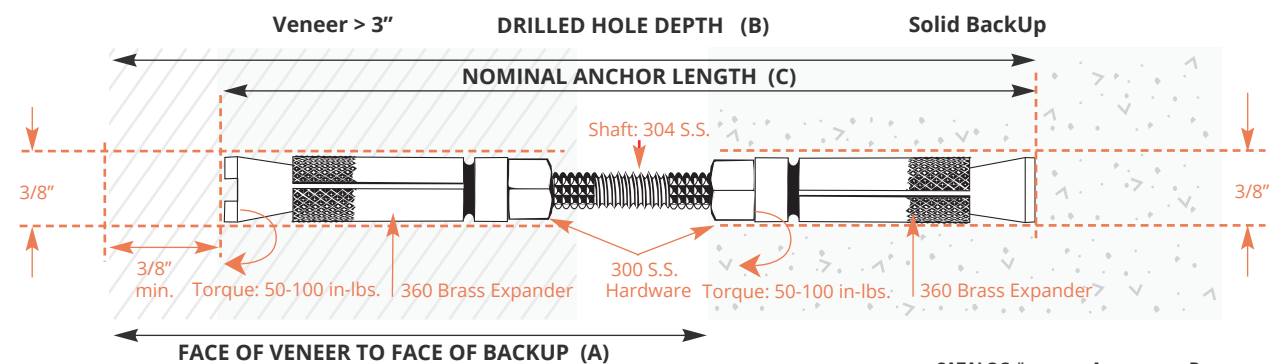

1. Select proper anchor length based on face of veneer to face of back-up (dimension A).
2. Drill appropriate hole through mortar joint to depth illustrated (C).
3. Blow out drill fines.
4. Fit threaded shaft, with expander assembly opposite, to the 501R setting tool. (Hex bolt on tool MUST be seated) thread shaft into tool until it stops; Insert assembly into drilled hole until it bottoms; Tighten 50-100 in-lbs.
5. Remove tool by holding firmly and loosening the hex bolt, then spin tool off anchor shaft by hand.
6. Place outer brass shield over main body (slots facing outward) and slide over shaft until it stops against nut; Place slot of tapered cone onto the 501R tangs; Position tapered cone onto shaft and tighten 50-100 in-lbs.
7. Remove tool, patch hole.

CATALOG #	A	B	C
62210-550	4 - 6"	6 1/2"	6"
62210-650	4 - 7"	7 1/2"	7"
62210-750	4 - 8"	8 1/2"	8"
62210-850	4 - 9"	9 1/2"	9"

Other lengths available upon request

INSTALLATION

5100 SERIES ANCHOR

Installation procedure and criteria for hollow backup

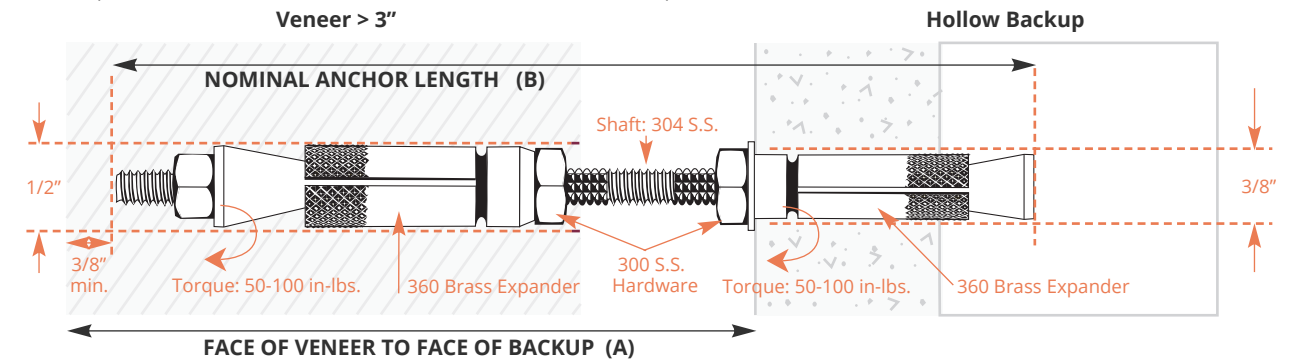

1. Select proper anchor length based on face of veneer to face of backup (dimension A).
2. Drill 1/2" hole through "tee" joint (no impact) and a 3/8" hole in the backup, at least 2" deep, using a 3-jaw chuck hammer drill on rotary-hammer mode, or a sds+ drill on rotary-only mode.
3. Blow out drill fines.
4. Assemble threaded portion of complete anchor assembly to the Grip-Tie 501 Setting Tool. (Hex bolt on the setting tool MUST be seated), thread shaft into setting tool until it stops; Insert assembly into drilled hole until it bottoms; tighten 50 - 100 in-lbs.
5. Remove tool by holding firmly and loosening the hex bolt, then spin tool off anchor shaft by hand.
6. Slide socket drive and adaptor onto the square drive of the 501 tool and on to the 5/16" nut of the installed anchor, tighten 50 - 100 in-lbs.
7. Remove socket, patch hole.

CATALOG #	A	B
62220-550	4 - 5"	5 1/2"
62220-650	5 - 6"	6 1/2"
62220-750	6 - 7"	7 1/2"
62220-850	7 - 8"	8 1/2"

Other lengths available upon request

5200 SERIES ANCHOR

Installation procedure and criteria for steel backup

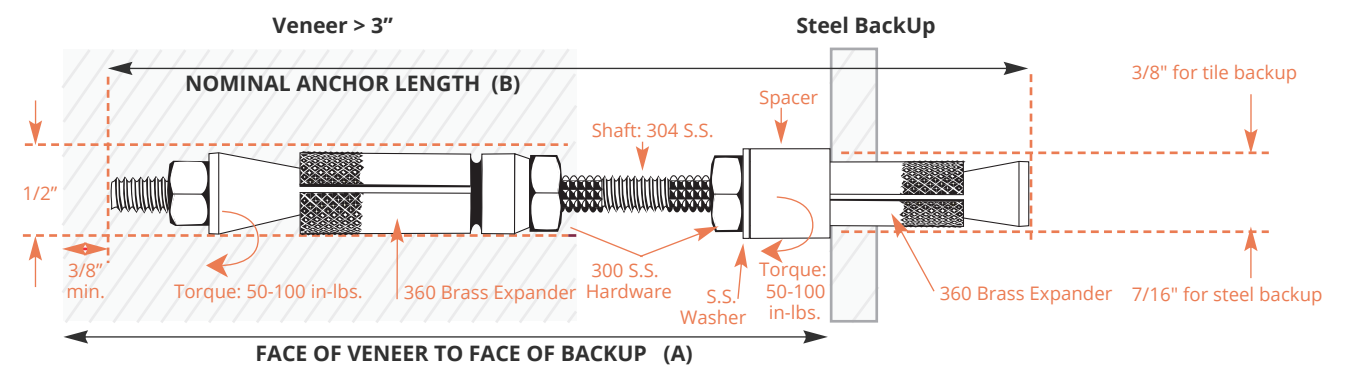

1. Select proper anchor length based on face of veneer to face of backup (dimension A).
2. Drill 1/2" hole through mortar joint (no impact) and a 3/8" hole for tile backup, or 7/16" hole in the steel backup.
3. Blow out drill fines.
4. Assemble threaded portion of complete anchor assembly to the Grip-Tie 501 Setting Tool. (Hex bolt on the setting tool MUST be seated), thread shaft into setting tool until it stops; Insert assembly into drilled hole until it bottoms; tighten 50 - 100 in-lbs.
5. Remove tool by holding firmly and loosening the hex bolt, then spin tool off anchor shaft by hand.
6. Slide socket drive and adaptor onto the square drive of the 501 tool and on to the 5/16" nut of the installed anchor, tighten 50 - 100 in-lbs.
7. Remove socket, patch hole.

CATALOG #	A	B
62230-550	4 1/2 - 5 1/2"	5 1/2"
62230-650	5 1/2 - 6 1/2"	6 1/2"
62230-750	6 1/2 - 7 1/2"	7 1/2"
62230-850	7 1/2 - 8 1/2"	8 1/2"

Other lengths available upon request

INSTALLATION

5300R SERIES ANCHOR

Installation procedure and criteria for stud backup

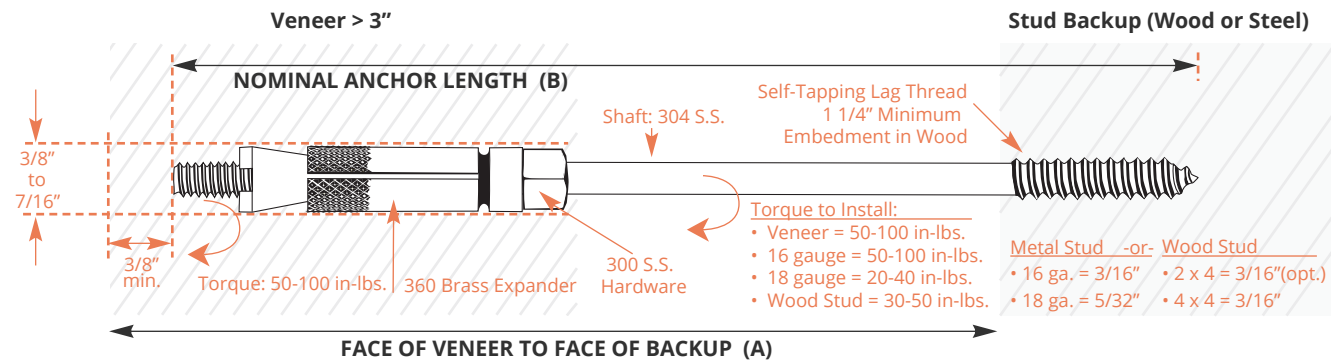

1. Select proper anchor length based on face of veneer to face of backup (dimension A).
2. Drill appropriate hole in mortar joint at stud location using a rotary hammer or hammer drill. Rotary only in soft material.
3. Drill 3/8" hole through outer wythe of material.
 - For metal stud, a 5/32" pilot hole is needed for 18, 20 and 22 gauge stud, a pilot hole of 3/16" for 16 gauge and greater is required.
 - For wood stud backup, a pilot may not be needed, 3/16" if necessary.
4. Blow out excess drill fines.
5. Assemble threaded portion of anchor shaft to the Grip-Tie 501R Setting Tool. (Hex bolt on the setting tool must be fully seated) thread anchor shaft into setting tool until it stops.
6. Insert entire assembly into drilled hole until the pointed end of the shaft makes contact with the stud, firmly thread by hand in drilled hole backup.
7. Rotate tool clockwise and tighten backup anchor to torque listed in figure above and remove setting tool.
8. To remove setting tool, loosen bolt head while holding setting tool firmly, spin off by hand.
9. Insert the 501 RSP (unthreaded) setting tool over the exposed thread and into the slotted cone. Tighten to between 50-100 in-lbs.
10. Remove tool, patch hole.

CATALOG #	A	B
62250-450	4 – 5"	4 1/2"
62250-550	5 – 6"	5 1/2"
62250-650	6 – 7"	6 1/2"
62250-750	7 – 8"	7 1/2"
62250-850	8 – 9"	8 1/2"

Other lengths available upon request

ACCESSORIES

SPECIAL DUAL DIAMETER DRILL BITS

8" and 14" Dual Diameter Drill Bits for 5100 Series

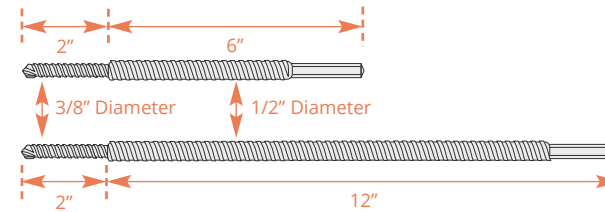

SETTING TOOLS

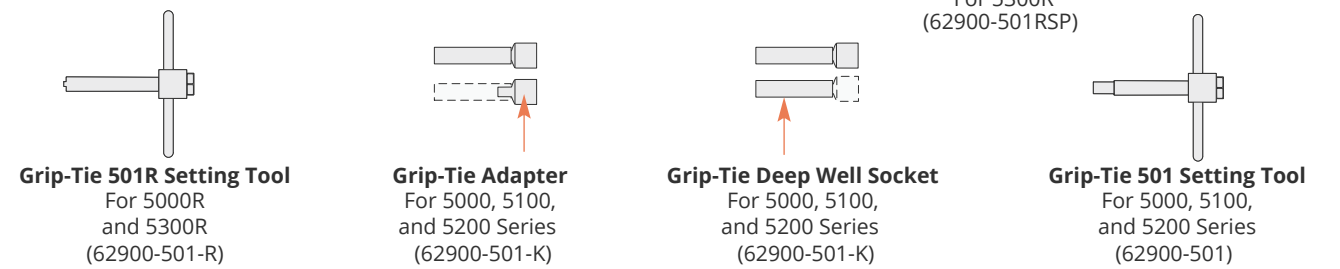

Notes

Warning

Seller makes no warranty of any kind, expressed or implied, except that the goods sold under this agreement shall be of the standard quality of the seller, and buyer assumes all risk and liability resulting from the use of the goods, whether used singly or in combination with other goods. Seller neither assumes nor authorizes any person to assume for seller any other liability in conjunction with the sale or use of the goods sold, and there is no oral agreement or warranty collateral to or affecting this transaction.

Warning

The information contained in this publication does not constitute any professional opinion or judgement and should not be used as a substitute for competent professional determinations. Each construction project is unique and the appropriate use of this product is the responsibility of the engineers, architects, and other professionals who are familiar with the specific requirements of the project.

Approval



PROSOCO



You. Us. The project.

PROSOCO's nationwide network of field reps and technical advisers from coast to coast are here to help solve your biggest problems, your smallest problems and everything in between.



Phone support
1-800-255-4255



Job-site support
When and where you need it.



Training
Ensure the job's done right.

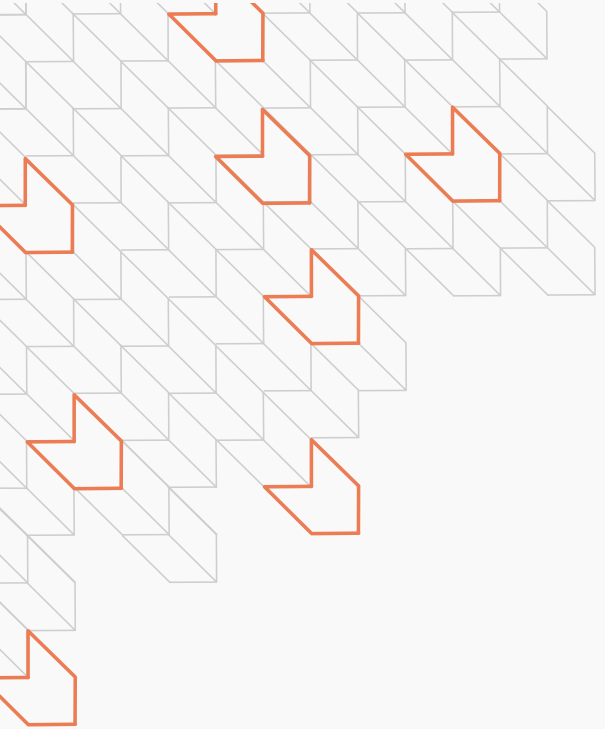

You. Us. The project.

We strive to provide the best construction products on the market, but we also know this business is about people. That's why we dedicate our human resources and services to make your job easier. Our nationwide network of sales representatives is here to do whatever we can to help solve your job-site problems.

JOHN
Field Support
Our on-site service includes troubleshooting, training and installation support.



JEFF
Engineering Support
Engineering details and personalized solutions for your specific needs.



COLLEEN
Customer Care
We're real live people who answer the phones!
Really. We're here M-F, 8a-5p, CST.



BRIAN
Field Support
We come to you to support your projects when and where you need us.

