



US 20120128144A1

(19) **United States**

(12) **Patent Application Publication**
Chislett et al.

(10) **Pub. No.: US 2012/0128144 A1**

(43) **Pub. Date: May 24, 2012**

(54) **SCREENING SYSTEM AND METHOD**

Publication Classification

(75) Inventors: **Edmund Chislett, Aurora (CA);
Matthew Jason Stein, Maple (CA);
Robert Gordon Thompson,
Toronto (CA)**

(51) **Int. Cl.**
H04M 3/42 (2006.01)

(52) **U.S. Cl.** **379/201.01**

(73) Assignee: **Primus Telecommunications
Canada Inc., Toronto (CA)**

(57) **ABSTRACT**

(21) Appl. No.: **13/363,723**

(22) Filed: **Feb. 1, 2012**

A system and method for screening incoming communications to a subscriber telephone number comprises a screening list of telephone numbers assigned to suspect incoming communication originators and rules defining when a telephone number will be added to or removed from the screening list or 'greylist,' and/or modifying a screening value to be assigned to a telephone number in the greylist. Data relating to an incoming communication is received from subscribers and processed, and the telephone number is screened in accordance with the rules, based on the screening value assigned to the telephone number and optionally a selected subscriber tolerance level. Subscribers may add any telephone number to a personal list of telephone numbers to be blocked (blacklist) or telephone numbers to be accepted (whitelist).

Related U.S. Application Data

(63) Continuation of application No. 12/673,377, filed on Feb. 18, 2011, filed as application No. PCT/CA2008/001465 on Aug. 13, 2008.

(30) **Foreign Application Priority Data**

Aug. 15, 2007 (CA) 2597977

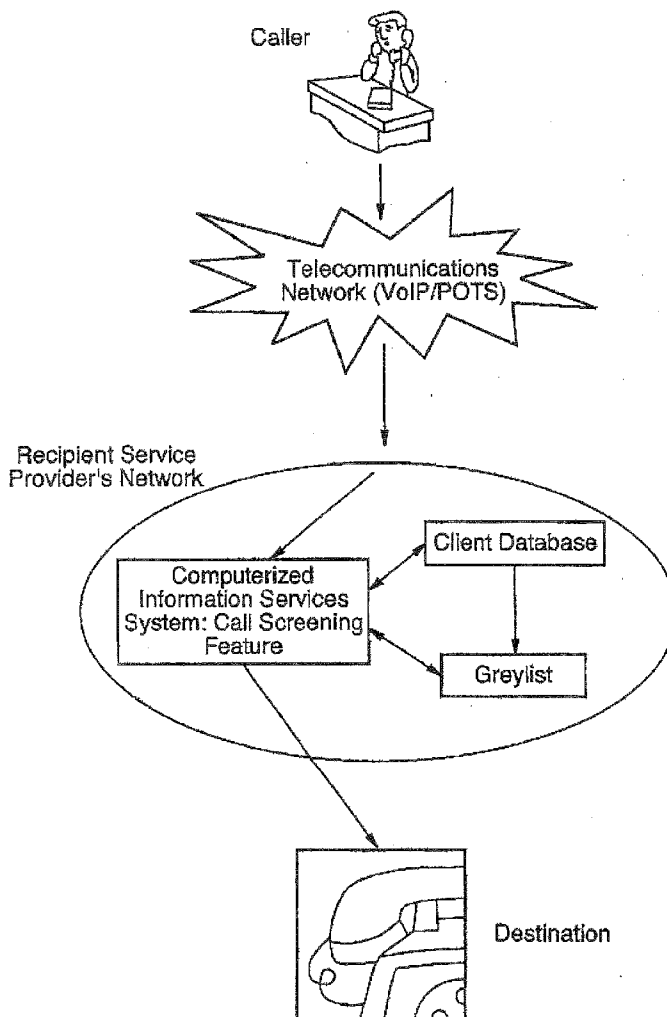

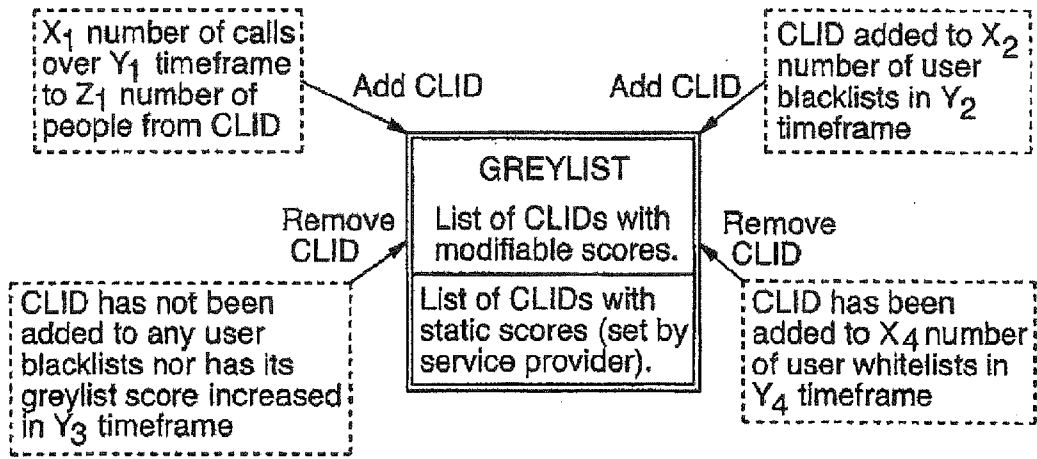

FIG.1

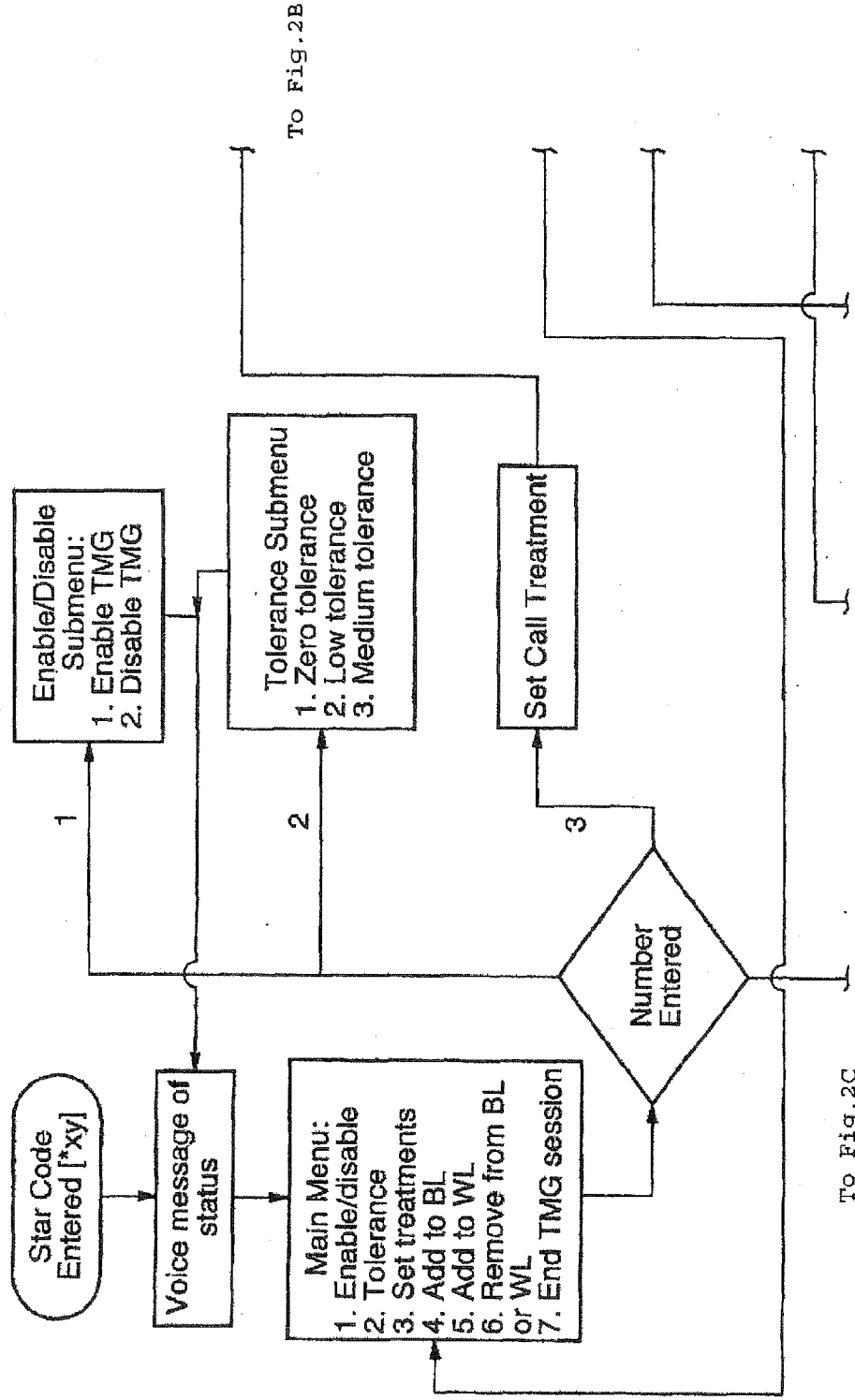

FIG. 2A

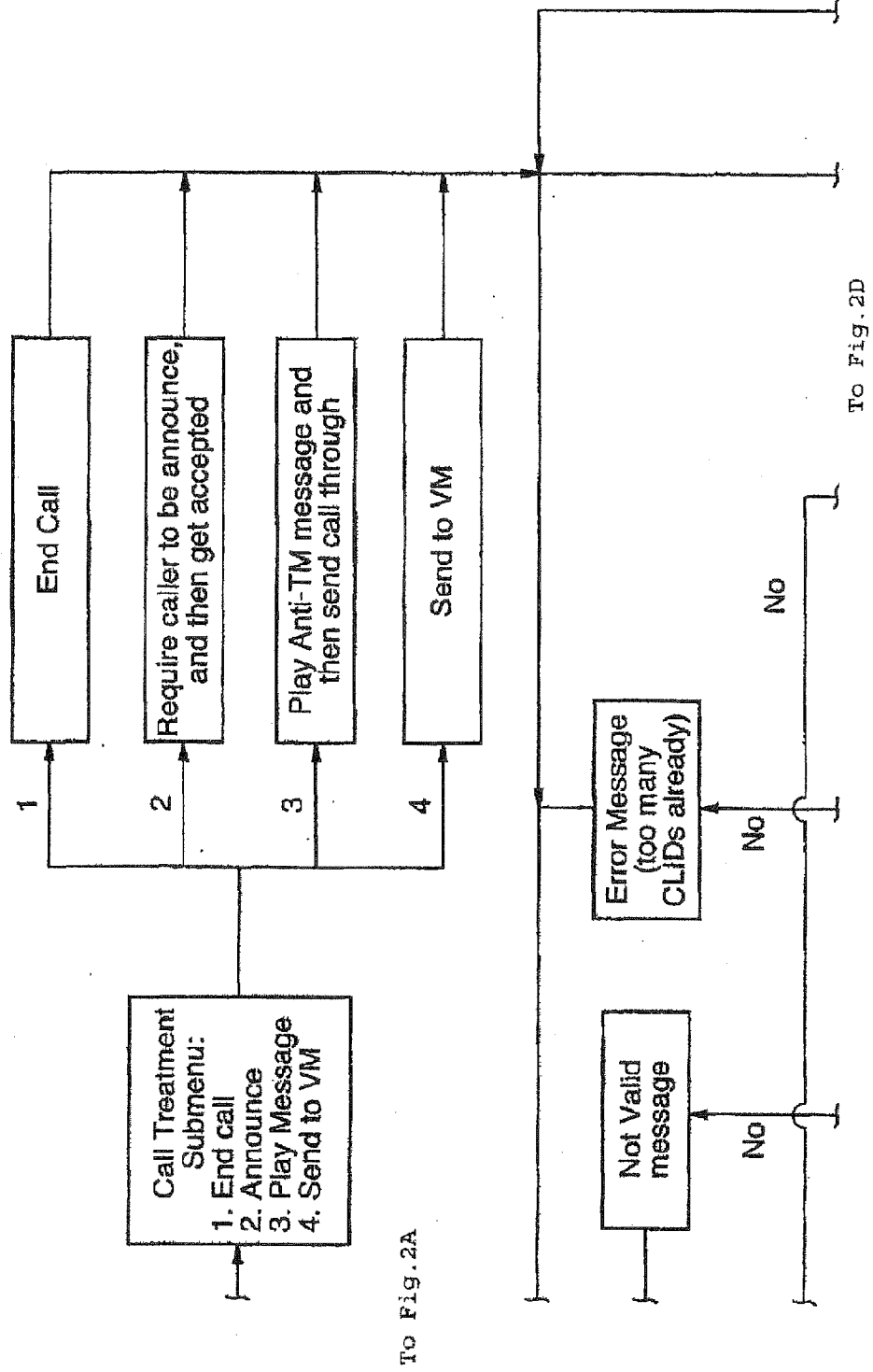
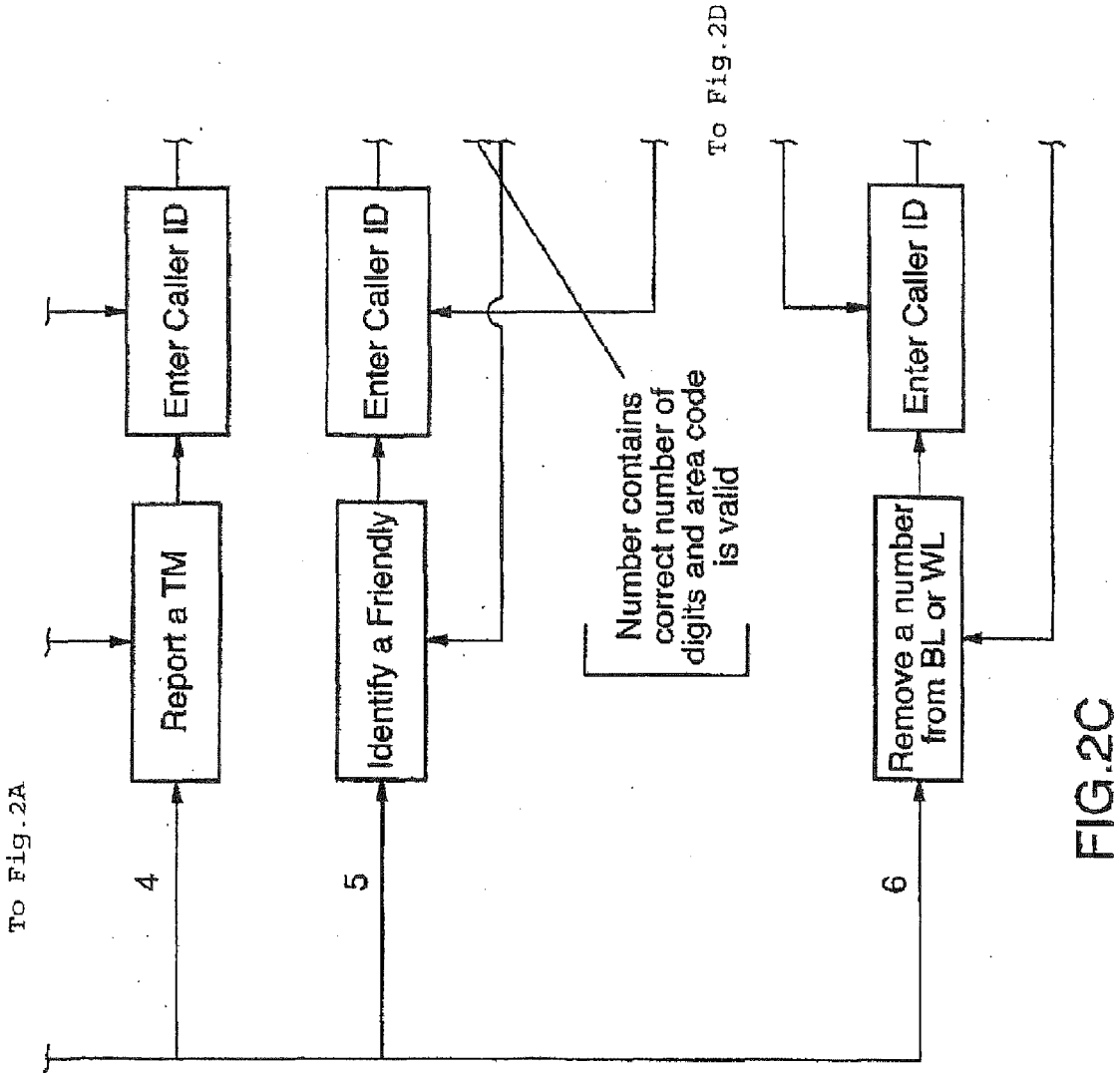

FIG.2B



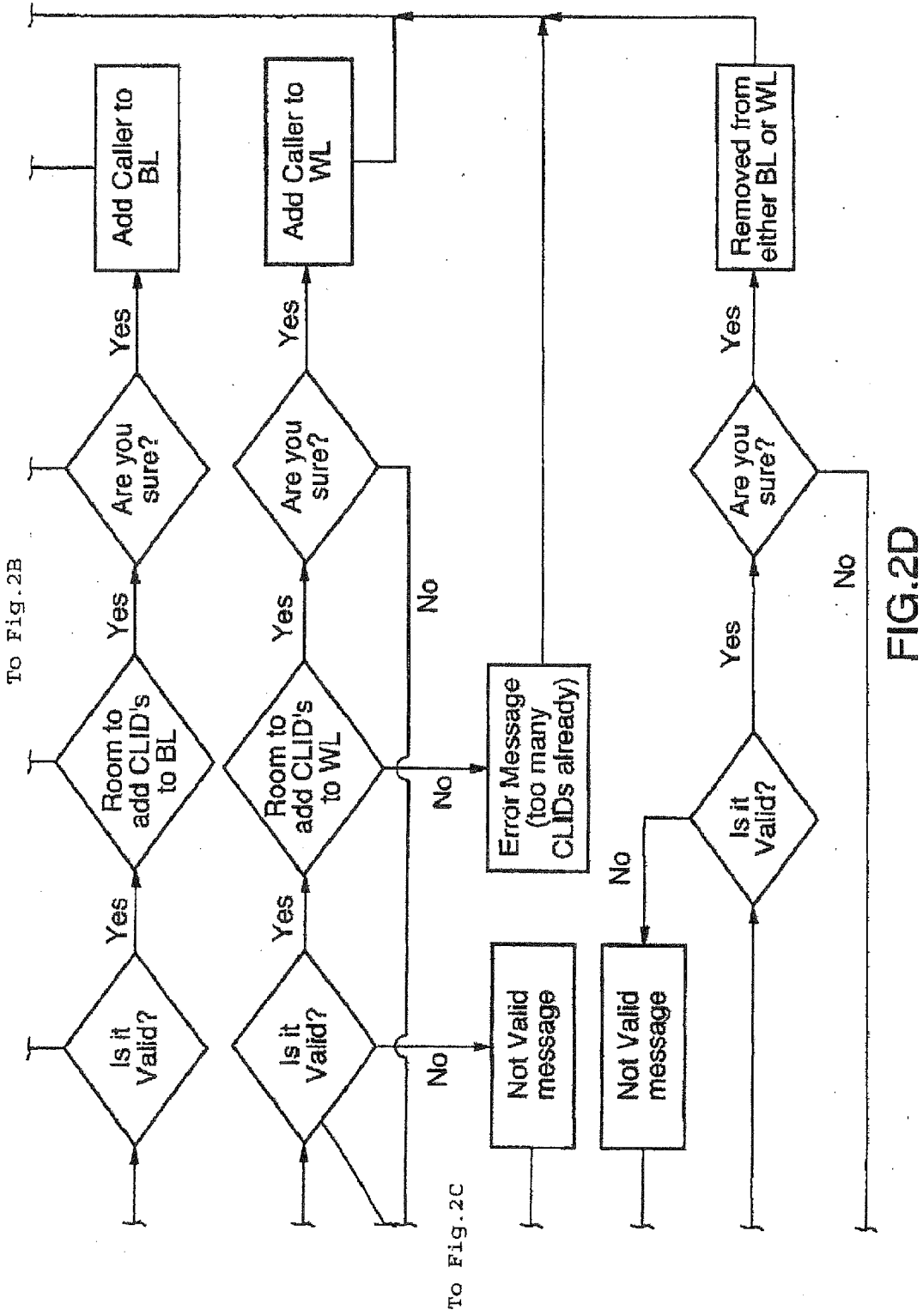

FIG.2D

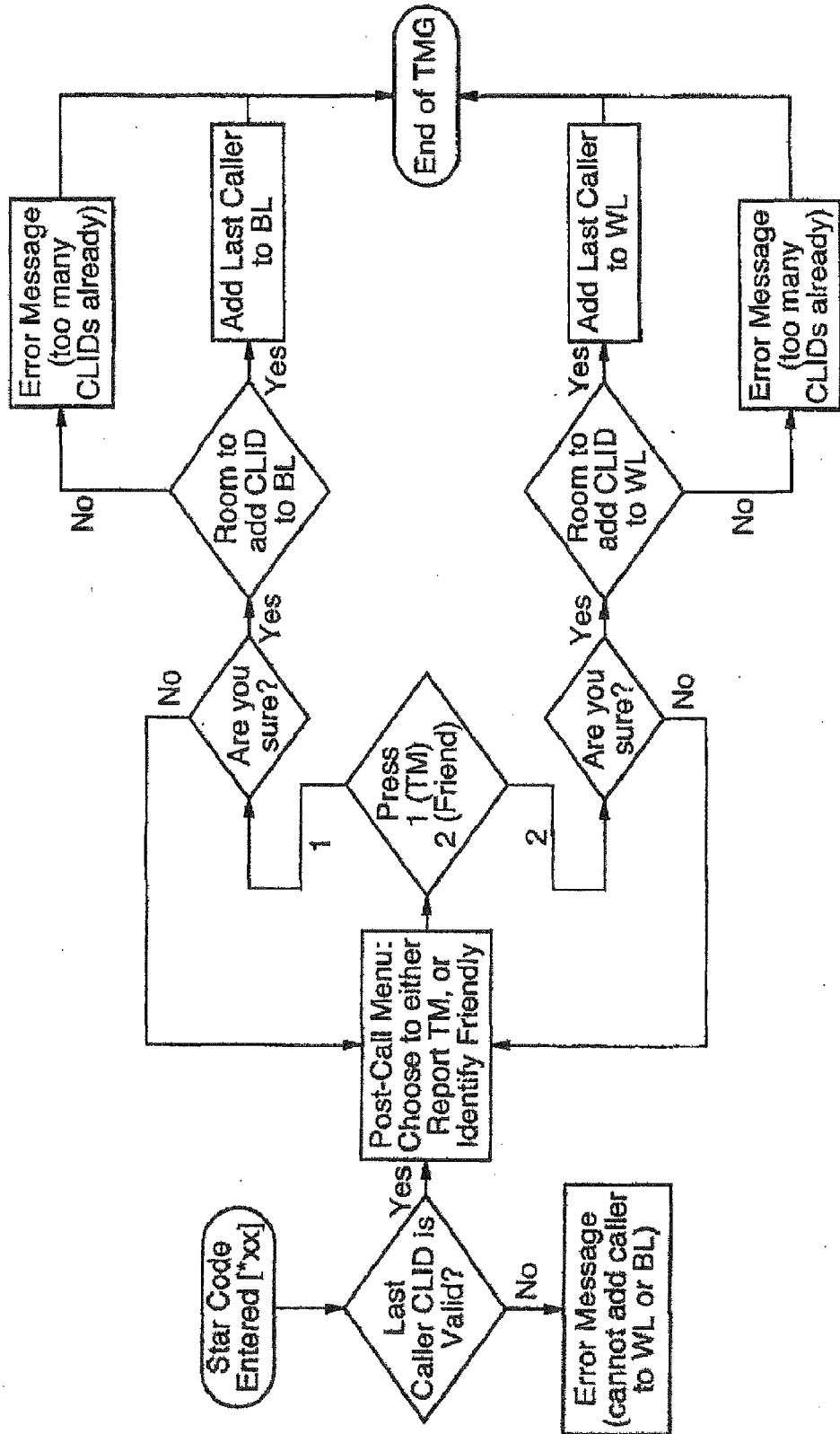

FIG.3

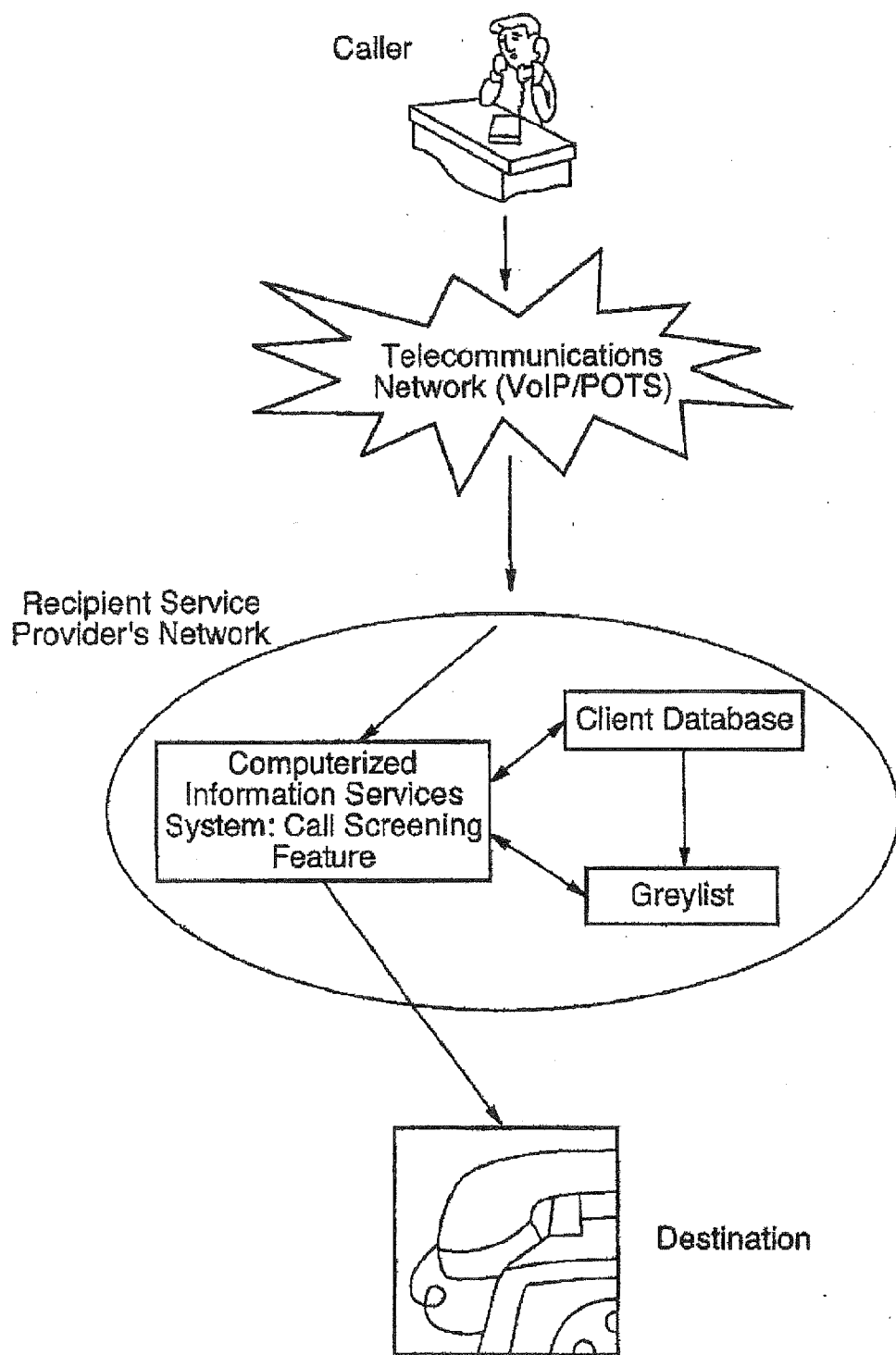

FIG.4

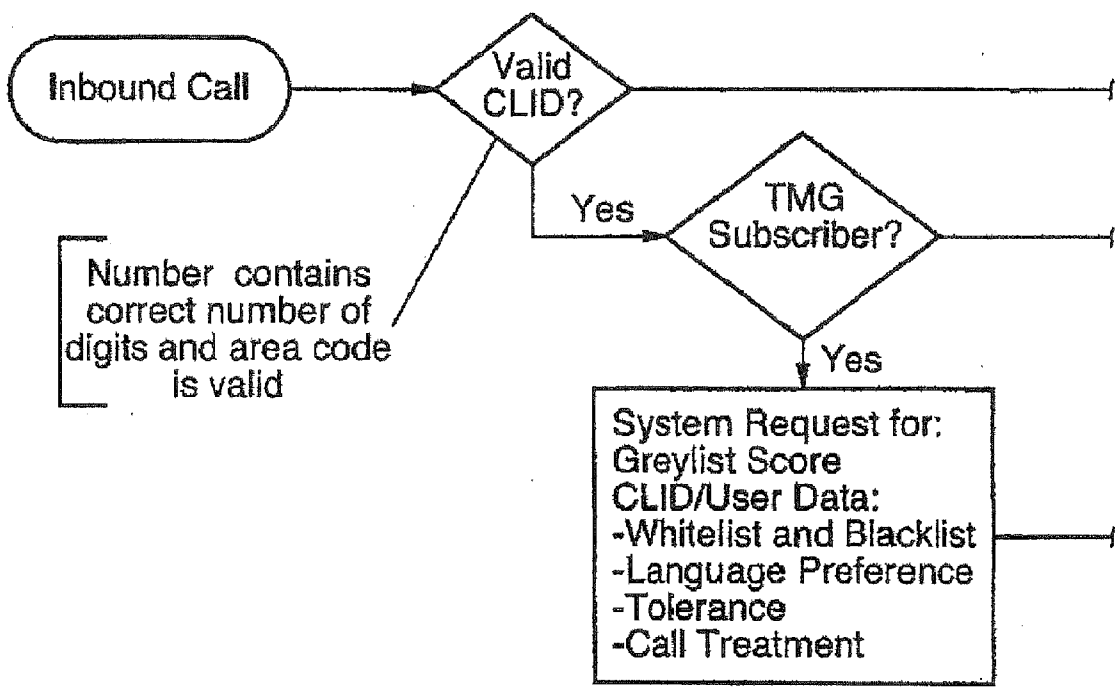

FIG.5A

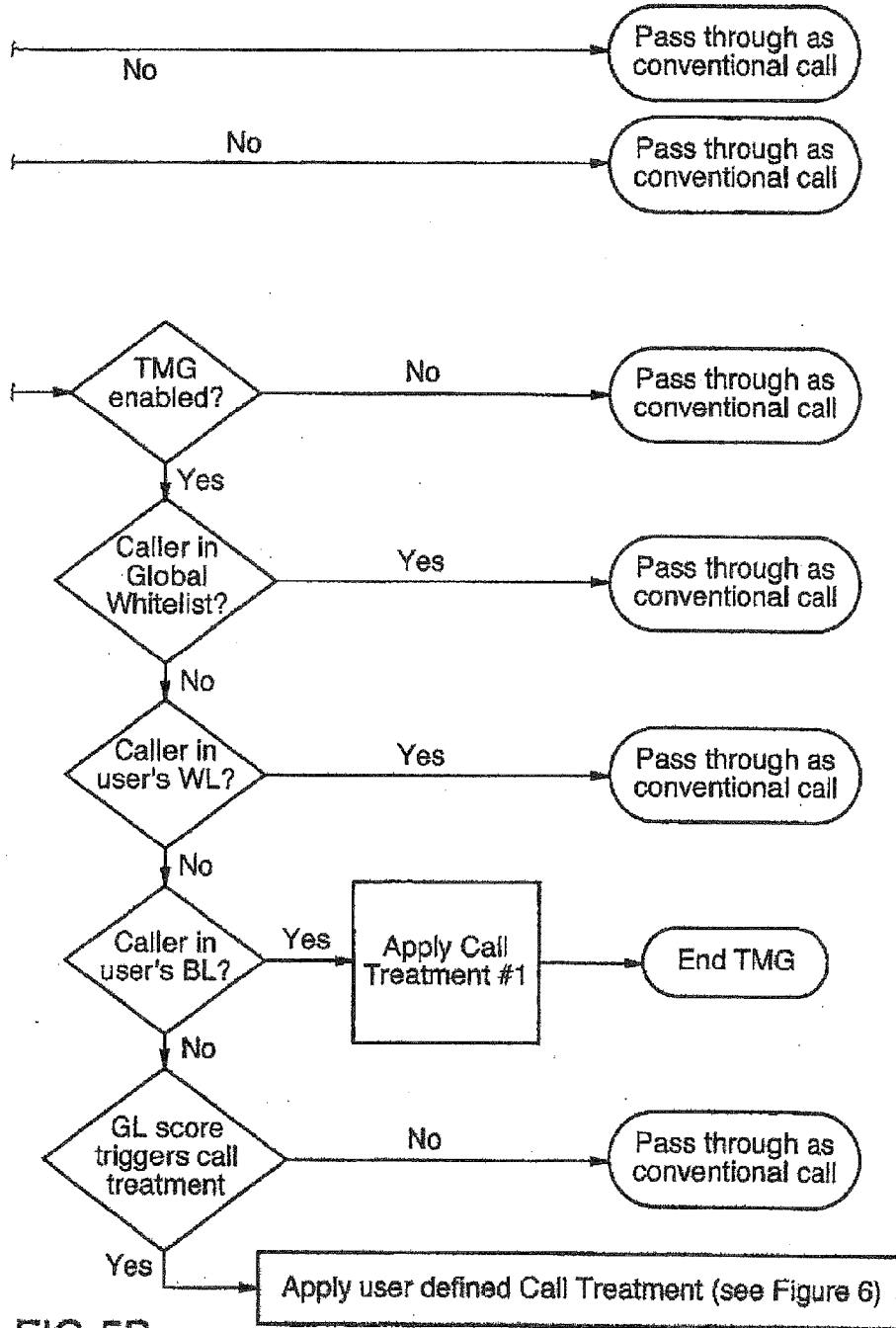

FIG.5B



FIG.6A

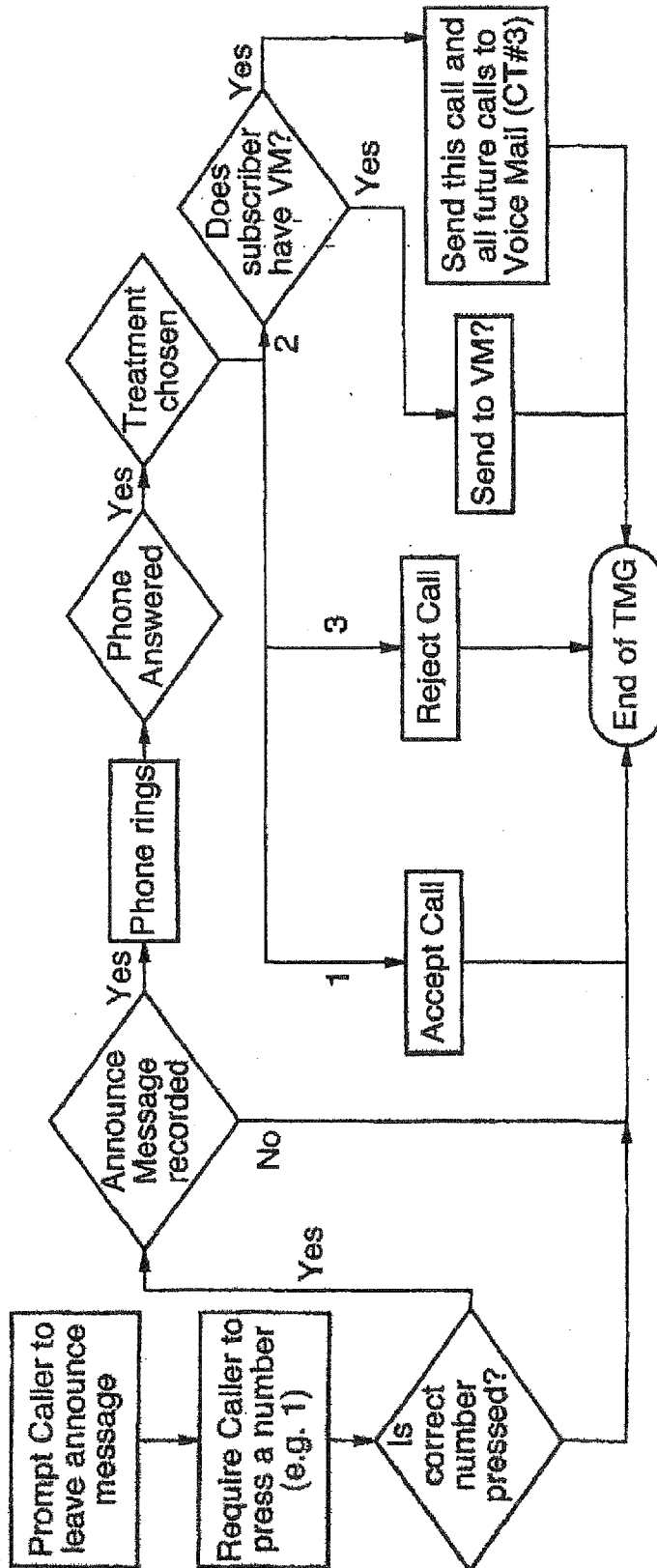

FIG. 6B

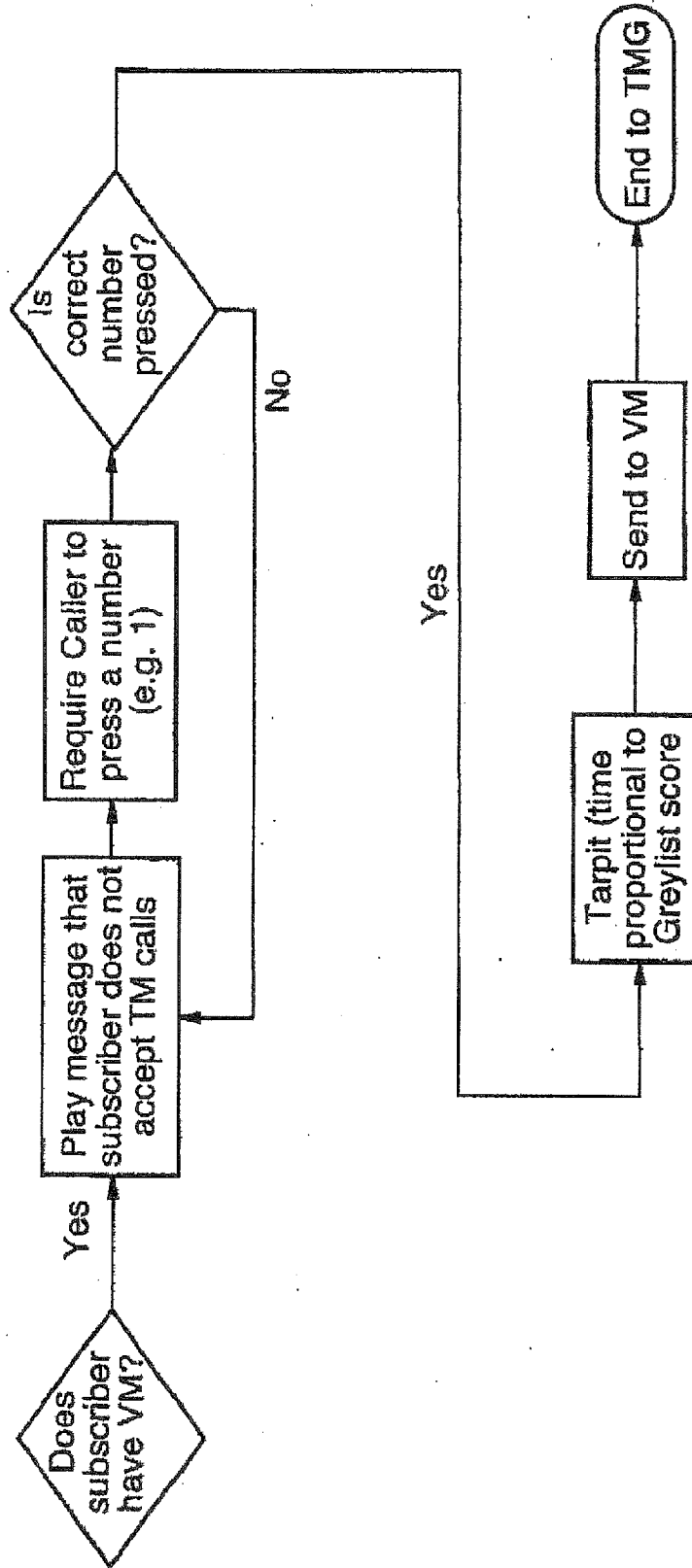

FIG. 6C

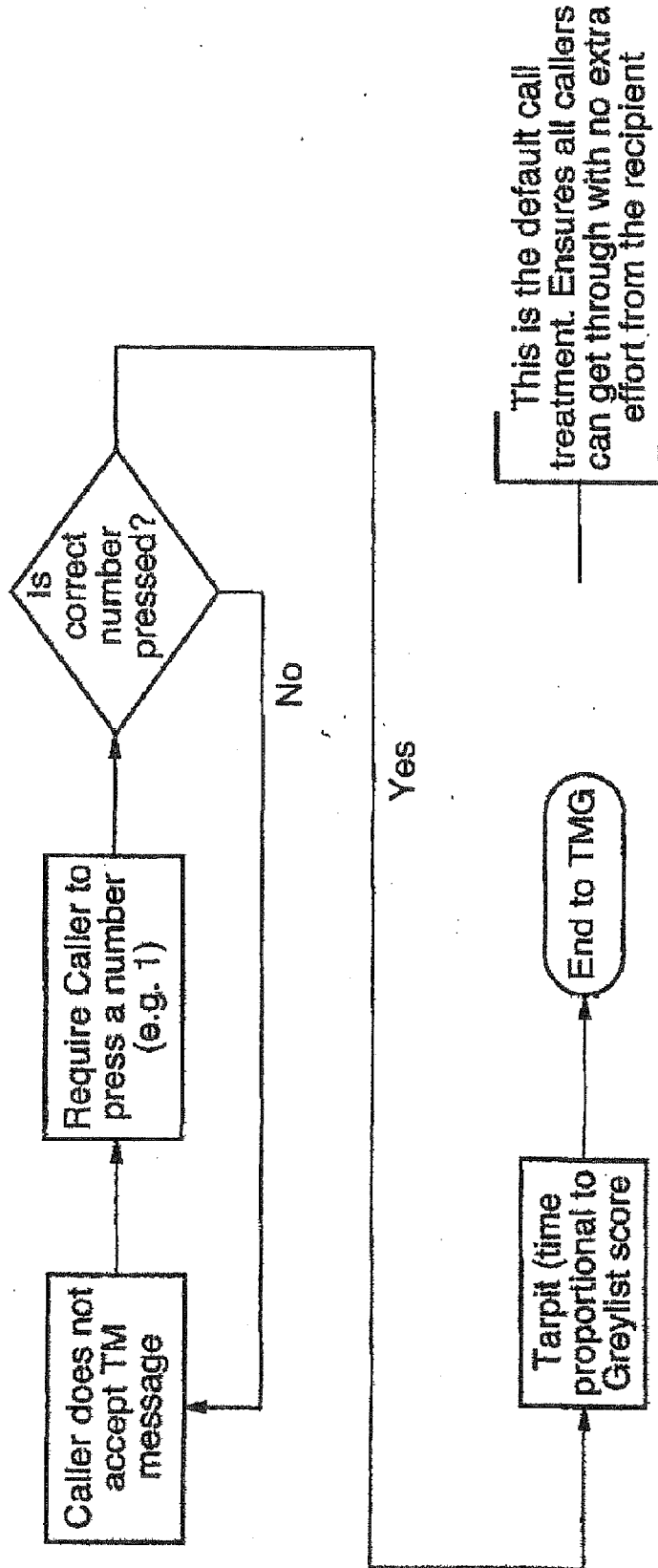

FIG. 6D

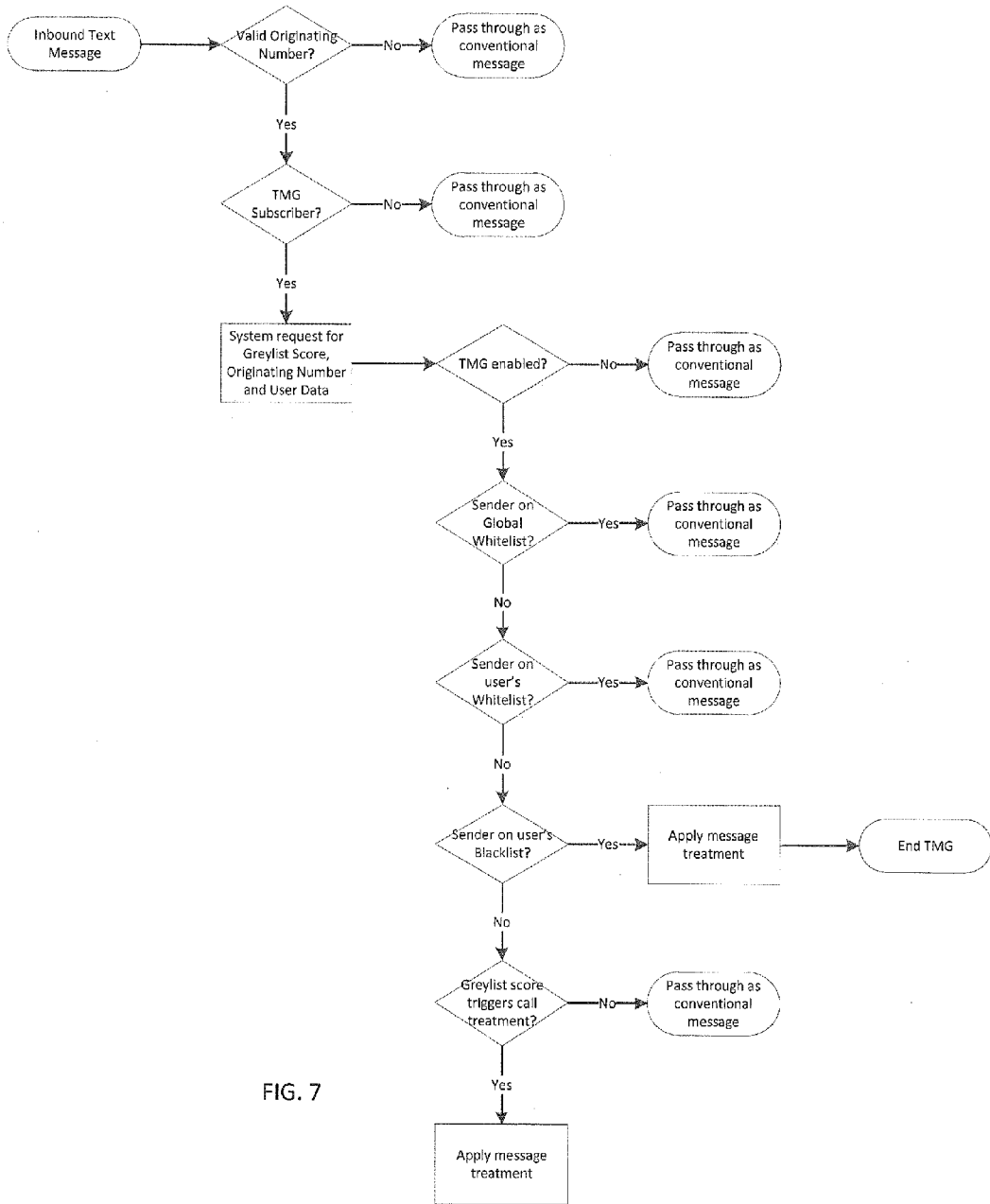

FIG. 7

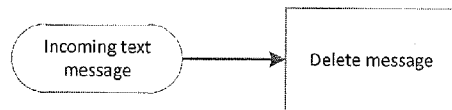

FIG. 8A

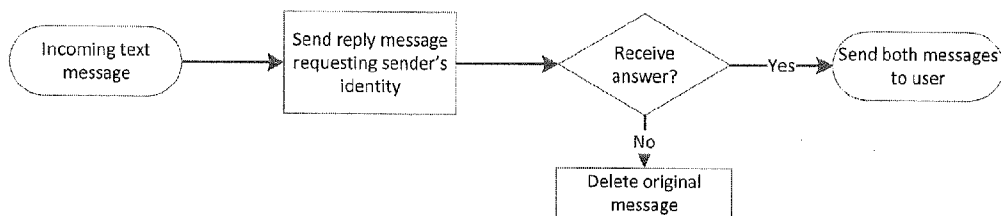

FIG. 8B

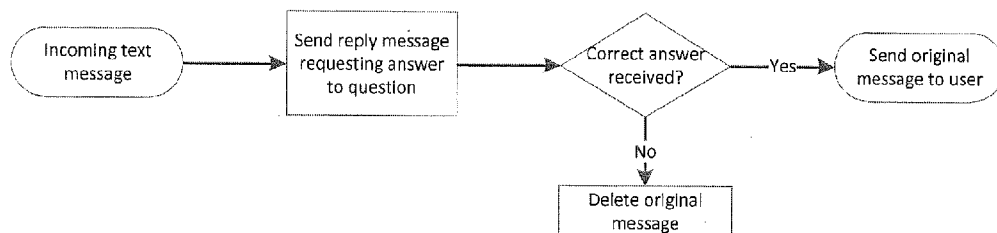

FIG. 8C

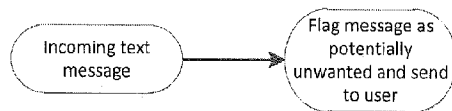

FIG. 8D

SCREENING SYSTEM AND METHOD

FIELD OF THE INVENTION

[0001] This invention relates to an incoming communications screening system. In particular, the invention relates to an automated system and method for enabling users to block and manage unwanted calls, text messages.

BACKGROUND OF THE INVENTION

[0002] Unsolicited telemarketing communications, such as incoming calls have been identified by the Canadian and American governments as a serious problem, as is evident in the fact that both countries have initiated the implementation of national ‘do not call lists’ (DNCL). Rules regarding DNCL, have numerous proposed exceptions to telemarketing rules that will allow charities, political parties, polling companies, businesses with existing business relationship, and others to telemarket to those listed on the DNCL. In addition to those entities who will still be allowed to call numbers registered on the DNCL, there will likely still be noncompliant telemarketers who call numbers listed on the DNCL.

[0003] Several means of screening and/or blocking unwanted calls, such as telemarketing calls, currently exist. For example, some telecommunications companies offer call-blocking services which allow subscribers to manually manage all calls from specific callers or category of calls (e.g. all 900 calling codes, all toll-free codes, or all calls where caller identification information is unavailable) that the subscriber identifies. The limitation of such call-blocking services is that they are static lists with little or no exclusion capabilities and may only capture a fraction of the telemarketing calls; the blocking parameters have to be determined in advance; and they may prevent desired calls from reaching the recipient.

[0004] There are electronic devices on the market which automatically remove the assigned telephone number of the receiving line from computer dialled telemarketing call-lists, by sending a tone when the user picks up the call that falsely indicates to the calling computer that the number is disconnected, so the computer deletes the phone number. This solution does not spare the user from the disturbance of the call, as the call must be answered in order for the device to take effect, and is limited to computer-initiated telemarketing calls. Also, each user cannot take advantage of the experience of other users.

[0005] In another example of incoming communications, mobile phone users can also receive text messages or SMS messages (short message service) that typically consist of a message in the form a short piece of text. Like phone calls, text messages include a sender identifier, often a phone number. Various extended formats for short messages such as XMS (eXtended Messaging Service) have similar functionality for the purposes of this application.

[0006] Mobile phone users may receive unwanted text messages such as marketing, advertising or similar messages. In addition to merely being unwanted, in some instances unwanted text messages may cost the mobile phone user money. Mobile phone users may be required to pay their mobile phone service providers for each text message they receive—whether wanted or unwanted. While recipients may delete the unwanted messages, the user is still interrupted and

can not take advantage of the experience of other recipients of messages from the same originator.

BRIEF DESCRIPTION OF THE DRAWINGS

[0007] In drawings which illustrate by way of example only a preferred embodiment of the invention,

[0008] FIG. 1 is a schematic view of a list of suspect callers (‘greylist’) and examples of rules that may be associated with the greylist.

[0009] FIGS. 2A, 2B, 2C and 2D illustrate a flowchart depicting one embodiment of a telephone call screen management system (TMG) according to the system and method of the invention.

[0010] FIG. 3 is a flowchart depicting an embodiment of a post-call management system according to the invention.

[0011] FIG. 4 is a schematic illustration of how an inbound call may be treated in the system of FIGS. 2A, 2B, 2C and 2D.

[0012] FIGS. 5A and 5B illustrate a flowchart of the call process flow through the call screening system in the system of FIGS. 2A, 2B, 2C and 2D.

[0013] FIGS. 6A, 6B, 6C and 6D illustrate flowcharts of the processing options of a call flagged as being from a telemarketer (TM) in the system of FIGS. 2A, 2B, 2C and 2D.

[0014] FIG. 7 illustrates a flowchart of a message processing flow through the screen system.

[0015] FIGS. 8A, 8B, 8C and 8D illustrate flowcharts of the processing options of a message flagged as being from a telemarketer in the system.

DETAILED DESCRIPTION OF THE INVENTION

[0016] Embodiments of the present invention are described below and illustrated in the Figures by way of example only. As used in the following description, the term “CLID” means “calling line identification number” and refers to a caller’s assigned telephone number or originating number, whether or not the identity of the caller can be determined. The telephone number may be a CLID, or may be an Automatic Number Identification (ANI) or a telephone number in any other form. The term CLID is used herein solely by way of example of a telephone number format which can be used in the implementation of the invention. For text messages, certain protocols have an originating number which contains information about the sender of the message. The sender ID or originating number serves to identify the party originating the message.

[0017] In one preferred embodiment the invention creates a screening list comprising a dynamic list of suspect originating numbers, or a “greylist,” comprising a list of originating numbers, for example in the form of telephone numbers in conformance with the North American Numbering Plan (NANP), or in any other desired format, along with score ratings as to the likelihood of the originating number being that of a telemarketer (TM) or other unwanted caller or originator of text messages. The greylist may be stored in a database maintained by the service provider at a central office or node, for example as a lookup table, and in the preferred embodiment is made accessible to all subscribers to the screening feature. The service provider may typically be a telephone company (Telco), and for ease of description the term ‘Telco’ will be used by way of example throughout this description when referring to the service provider, but the service provider can be any entity administering the communication blocking feature whether in a conventional telephone system, wireless system, VOIP system, or otherwise.

[0018] The screening list or “greylist” comprises originating numbers which one or more users have identified as belonging to a telemarketer or other undesirable caller or originator of text messages, as determined by the service provider or system administrator. The screening list can also be created and/or updated by the service provider entering call or messaging data into the system, for example through one or more algorithms which can identify which of the users in the system may be a telemarketer, examples of which are set out below. The users of the system can manage the incoming originating numbers by utilizing a list of acceptable originating numbers or ‘whitelist’ (WL) that the user has identified as being friends, family or other acceptable callers; and a list of unacceptable originating numbers or ‘blacklist’ (BL) that the user has identified as unwanted callers. The blacklist and whitelist may be stored in a client database maintained at the Telco server, and optionally also stored locally at the subscriber’s premises or mobile phone in order to reduce the need for communications between the Telco and the subscriber when determining how to treat an incoming call or message.

[0019] According to the invention, the whitelist and blacklist are personal to the subscriber, while the greylist is a communal list, common to all subscribers to the screening system. Thus, depending upon the rules adopted by the service provider or system administrator, an originator, ie a caller or sender, may be moved to the greylist or its greylist score increased by the event of being added to one or more subscriber’s blacklists, either over a specific time interval, cumulatively, or some other process. Some factors that might be considered when moving an originator to the greylist or increasing the originator number’s greylist score include the frequency between calls and which originator number gets placed on subscribers blacklists or whitelists.

[0020] In an embodiment the invention may comprise a computer program product embodied on a tangible medium for operation on telecommunications hardware for carrying out a method of screening telephone calls or text messages, the program product operative to carry out the steps of: a. maintaining on memory in the telecommunications hardware, a screening list of telephone numbers assigned to suspect callers and/or message senders; b. storing on memory in the telecommunications hardware, one or more rules defining when an assigned telephone number will be added to or removed from the screening list, or modifying a screening value to be assigned to an assigned telephone number on the screening list, or both; c. receiving data relating to suspect callers and/or text message senders; d. applying the one or more rules to the data; e. adding to or removing from the screening list the assigned telephone number, or modifying the screening value assigned to the assigned telephone number, or both, based on the application of the one or more rules to the data; and f.

[0021] screening a call from the assigned telephone number to a subscriber in accordance with one or more rules based on the assigned telephone number being in the screening list or on the screening value assigned to the assigned telephone number, or both.

[0022] FIG. 1 illustrates examples of some rules that can be implemented to create and maintain the greylist for originator’s telephone numbers. It will be appreciated that these rules are provided by way of non-limiting example solely to illustrate the principles of the invention.

[0023] As illustrated in FIG. 1, using the example of a caller’s telephone number, the greylist comprises a sublist of

CLIDs, or originating numbers, with their associated modifiable scores. The first sublist is populated automatically by applying rules to database queries. These rules may for example include the following:

[0024] 1. Add to the greylist any originating number that makes over X_1 number of calls over Y_1 timeframe to Z_1 number of people;

[0025] 2. Add to the greylist any originating number that has been added to X_2 number of user blacklists over a time interval of Y_2 ;

[0026] 3. Remove from the greylist any originating number that has not been added to any user blacklists and who’s greylist score has not increased over a time interval of Y_3 ; and/or

[0027] 4. Remove from the greylist any originating number that has been added to X_4 number of user whitelists (users’ independent lists of originating number that they have identified as being friends or family, stored on the client database) in Y_4 timeframe,

where the variables X, Y, and Z are threshold values set by the Telco (or other service provider or administrator of the system).

[0028] Whereas each individual subscriber determines whether an originating number should be assigned to his or her blacklist or whitelist, and effects this by manual assignment of an originating number to a particular list (for example using their dial pad or a voice recognition menu system), rules such as these are used to automatically assign an originating number to the greylist. In this embodiment, an originating number is added to the greylist based on data received from one or more subscribers (as dictated by the rules) and is assigned an initial score or s’ screening value’ by default. The screening value of a particular originating number is modified as further data relating to the originating number is received from subscribers. Once on the greylist, the originating number is flagged as a potential telemarketer (or other unwanted caller or sender of text messages) for all subscribers to the system. Thus, the more subscribers there are, the faster unwanted originators, such as callers or senders, become listed on the greylist and the entire community of subscribers benefits from the experiences of the other subscribers.

[0029] Preferably the greylist is associated with a second sublist that is populated by the service provider setting the scores associated with particular originating numbers. These scores cannot be modified by user input. One purpose for this sublist may be to store originating numbers that should never be flagged as a telemarketer, for example, essentially creating a “global whitelist.” For example, it may be desirable to ensure that certain originating numbers associated with government departments, police, telephone carriers, etc., and/or the service provider itself, are never blocked and cannot be inadvertently assigned to a greylist or blacklist.

[0030] The greylist is maintained and managed by the service provider, for example a Telco. No hardware other than the telephone equipment normally used by the user is required, for example the telephone set at their premises to make and receive telephone calls or their mobile phone. A conventional telephone or mobile phone set may be modified to store the whitelist and/or blacklist, which as noted above will allow the subscriber’s equipment to determine how to treat an incoming call or text message without the need for communications between the Telco and the subscriber. However, in an embodiment of the invention the decision to route

or block the call can be made at a routing point, for example the Telco's central office, gateway or node.

[0031] As shown in FIG. 4, the client database is part of the service provider's network and stores the user's telephone number, whitelist and blacklist amongst other things. It exchanges data with the service provider's information services system and provides the greylist with data such as query results. When a customer subscribes to the screening service, and thereby becomes a user, a record identifying the subscriber and associated with the subscriber's assigned telephone number is added to the client database. Customers who are not subscribed to the service may contribute to the functioning of the system. For example, if an originating number is used to try to contact many recipients in a short period of time, the system may put the originating number on a greylist or blacklist, even if many of the intended recipients are non-subscribers. In this way the experience of subscribers is improved based on the characteristics of communications over the entire system, both to subscribers and non-subscribers of the system.

[0032] In one embodiment, the system may use a 'watchlist' to monitor potential telemarketing originators. Originating numbers on the watchlist may be monitored more closely than other originating numbers to confirm if they are telemarketers or not. For example, originating numbers on the watchlist may be monitored for duration of the calls, the time of day for calls, or other criteria. By using a watchlist, the system benefits from only doing the more detailed monitoring on a shorter list of originators than all the originating numbers using the system or all the originating numbers on the greylist.

[0033] An exemplary embodiment of the invention is explained below with regarding to call screening by way of non-limiting example, in accordance with the exemplary embodiment shown in the drawings. It will be appreciated that the particular selection of parameters such as keystrokes, menus, functions, prompts, commands and others may be varied without departing from the principles of the invention, and the invention is not intended to be limited thereby.

[0034] A user can add an originating number to their blacklist and whitelist by manually entering the phone numbers to be accepted or blocked, for example using the dial pad on their telephone via the call screen management system (as shown in FIG. 2) or by reporting the last caller or sender through the same or a separate call screen management system or text message management system after the call is complete (as in FIG. 3). To gain access to the screening management system menu, the user dials a unique preset code, e.g., "*555" or menu option displayed on the screen of their phone. In either case this information is communicated to the Telco server, which applies the rules to the data received from the subscriber to add the originating number to the grey list, remove the originating number from the grey list, or modify the screening value or 'score' assigned to the originating number on the greylist, which facilitates the ability to set individual subscriber tolerance levels.

[0035] The following are some tools which may be accessed through menus in an automated attendant system. These examples are provided solely for illustrative purposes and are not to be construed as essential or an exhaustive list.

[0036] When the screening management system is first accessed, the user will be guided by an automated attendant (such as is commonly known to those skilled in the art) through a series of menus to set up their screening system.

The user may hear a voice message indicating the status of their screening management service, then a pre-recorded main menu, indicating to the user which number to press on their dial pad to change certain settings in the system or the system will display the current status and menu options on a display screen associated with their phone. FIGS. 2A, 2B, 2C and 2D depict an example of how the menu system can work in this embodiment of the invention. The user can be presented with the option of pressing "1" to access the Enable/Disable setting, pressing "2" to set the tolerance to be applied to the greylist scores (various thresholds for the list transfer parameters may be established by the telco), pressing "3" to set the desired method of treating the call or message, pressing "4" to add a telemarketing number to the user's blacklist and have the number reported to the greylist database, pressing "5" to identify a number to be added to the whitelist, pressing "6" to remove a number from the user's whitelist or blacklist, or pressing "7" to exit the call screen management system, etc.

[0037] In an example of a submenu, if the user presses "1" from the main menu, they would be presented with the options of pressing "1" to turn the screening system on, or pressing "2" to turn the screening system off. If the user then presses "1" they would hear a pre-recorded message confirming that the system has been enabled. If the user presses "2" they would hear a pre-recorded message confirming that the system has been disabled. The user would then be redirected to the main menu.

[0038] If the user presses "2" from the main menu to set their desired greylist tolerance, they would be presented with the option of pressing "1" to never allow any calls or messages through from originating numbers that have ever been marked as a telemarketer, pressing "2" to only allow callers or message senders through who have a score less than β_1 , pressing "3" to only allow callers or message senders through who have a score less than β_2 (where $\beta_2 > \beta_1$), or pressing "*" to return to the main menu. β_1 and β_2 are threshold score values set by the service provider for the low score tolerance and the medium score tolerance respectively. If the user selects anything other than "*" their selection will be confirmed and they will be redirected to the main menu.

[0039] If the user presses "3" from the main menu to set how they wish to handle calls or messages screened by the system, for calls, they will be presented with the options of pressing "1" to end the call (either immediately or after a predetermined interval, as shown), without the call ringing through, pressing "2" to require the caller to announce their identity and allow the user to accept or reject the call, pressing "3" to play a message indicating that the user does not accept telemarketing calls and to then pass the call through as a conventional call, pressing "4" to play a message indicating that the user does not accept telemarketing calls and to then send the caller through to the voicemail (VM) system (if the user has subscribed to such service), or pressing "*" to return to the main menu. If the user selects anything other than "*", their selection will be confirmed and they will be redirected to the main menu.

[0040] For messages, they may be presented with the options of pressing "1" to delete the message without a message notification (FIG. 8A), pressing "2" to deliver a reply message to the message sender requesting a further message providing identifying the sender's name and identity (FIG. 8B), pressing "3" to deliver a reply messaging to the message sender requesting a further message containing an answer to

a question such as the intended recipient's name (FIG. 8C), pressing "4" to deliver the message but with a message notification that the message may be unwanted (FIG. 8D). The options requiring the sender to send a further message are intended to identify human initiated messages, senders who are likely to receive the request for a further response and be able to provide the response. In one embodiment, the system requests an answer to a simple question such as to a simple mathematical equation. In the message treatments requiring a response discussed above, the system may maintain the original message in the system for a predetermined period of time until either a reply message is received from the original sender or the message is deleted. Many of the call treatments shown in FIGS. 6A, 6B, 6C and 6D are analogous to those message treatments shown in FIG. 8A, 8B, 8C and 8D. FIGS. 8A, 8B, 8C, and 8D show examples of these message treatment options.

[0041] If the user pressed "4" from the main menu, they will be prompted to enter the 7- or 10-digit telephone number of the telemarketer (TM) they want to add to their blacklist and thereby have reported to the greylist. The user will have the option of pressing "*" to return to the main menu. If the user enters a valid 7- or 10-digit number and there is room available on the user's blacklist, the number will be read back to the user or displayed on the screen of the phone and the user will be prompted to confirm that they want to add the number to their blacklist. If the user confirms that they wish to add the number to their blacklist, the number is added to the blacklist and a message is played or displayed to indicate that the number has been so added. The user will then be redirected to the main menu. If the user does not wish to proceed with adding the number that they entered onto their blacklist, they will be redirected back to the blacklist submenu. If the number that they enter is invalid, a message will be played or displayed to indicate that the number is invalid and the user will be redirected back to the blacklist submenu. If there is insufficient room on the user's blacklist for the number, an error message will be played or displayed and the user will be redirected to the main menu.

[0042] If the user pressed "5" from the main menu, they will be prompted to enter the 7- or 10-digit telephone number of the friend or family member, or other acceptable caller or message sender, which they want to add to their whitelist. The user will have the option of pressing "*" to return to the main menu. If the user enters a valid 7- or 10-digit number, the number will be read back to the user or displayed on the screen of the phone and the user will be prompted to confirm that they want to add the number to their whitelist. If the user confirms that they wish to add the number to their whitelist and there is room available on the user's whitelist, a message will be played or displayed to indicate that the number has been so added. The user will then be redirected to the main menu. If the user does not wish to proceed with adding the number that they entered onto their whitelist, they will be redirected back to the whitelist submenu. If the number that they enter is invalid, a message will be played or displayed to indicate that the number is invalid and the user will be redirected back to the whitelist submenu. If there is insufficient room on the user's whitelist for the number, an error message will be played or displayed and the user will be redirected to the main menu.

[0043] If the user pressed "6" from the main menu, they will be prompted to enter the 7- or 10-digit telephone number of the party they wish to remove from either their whitelist or

blacklist. The user will have the option of pressing "*" to return to the main menu. If the user enters a valid 7- or 10-digit number, the number will be read back to the user or displayed and the user will be prompted to confirm that they want to remove the number from their whitelist or blacklist. If the user confirms that they wish to remove the number from their whitelist or blacklist, a message will be played or displayed to indicate that the number has been removed. The user will then be redirected to the main menu. If the user indicates that they do not wish to proceed with removing the number that they entered, they will be redirected back to the submenu for removing a number. If the number that they enter is invalid, a message will be played or displayed to indicate that the number is invalid and the user will be redirected back to the submenu for removing a number.

[0044] The screening system may also provide the user with the option of hearing or displaying the numbers or names associated with the numbers on their blacklist and/or whitelist.

[0045] In a call screening embodiment, by entering a preset series of keystrokes, for example a *-number code, the user can access a post-call management tool that will add the last caller to their blacklist or whitelist (as in FIG. 3). Once the user gains access to this tool by dialling the assigned series of keystrokes, they will be given the option of reporting the last caller as a telemarketer and adding the number to their blacklist, or adding the last caller to their whitelist if the last CLID is valid. The user will then be prompted to confirm that they wish to take the action requested. If the user affirms their request and there is room on the appropriate list, the number will be added to the appropriate list. If the user responds in the negative, they will be redirected to the main menu. If there is no room left on the list to add another number, an error message will be played or displayed and the management session terminated. If the last CLID is invalid, an error message will be played or displayed and the call management session will be terminated.

[0046] In a text message screening embodiment, when a text message is received, the user can access a message management tool that will add the message sender to their blacklist, if the message is an unwanted message from a telemarketer or to their whitelist if the message is valid. The user may be prompted to confirm their selection. In one embodiment, the user may forward the unwanted text message to an address associated with the Telco or service provider for the screening system to add the originating number associated with the unwanted message to the blacklist.

[0047] All of the settings selected by the user may be stored in the client database at the Telco server.

[0048] At any menu, if the user fails to make a selection, the menu will replay a preset number of times or display for a preset amount of time and await a selection, failing which the session is terminated.

[0049] FIGS. 5A and 5B show how an inbound call may be processed. When an inbound call is detected, the system first checks to see that the originating number (or CLID) is valid, then the call screening system will look up the recipient telephone number in the client database and retrieve the user's settings. If the database indicates that the user has disabled the call screening system, the inbound call does not have a valid originating number, or the caller's originating number is on the user's whitelist, the inbound call will be connected to the recipient as any conventional call.

[0050] If the call screening system is enabled and the inbound call has a valid originating number, the Telco server software will conduct a lookup to determine whether the originating number is on the various lists maintained by the system. If the originating number is on the global or user's whitelist, the Telco server software will route the call through to the subscriber telephone line. If the caller's originating number is on the user's blacklist, then the incoming call is automatically terminated.

[0051] If the originating number is already on the greylist, the Telco server software will retrieve the current score associated with the originating number on the greylist. If no entry is found for the originating number, the Telco software will add it to the greylist and assign a default score of 1 to the originating number. If the score is below the level of tolerance selected by the subscriber, the call is routed to the subscriber as a conventional call. If the score is equal to or above the level of tolerance selected by the user, the call is flagged and the call treatment selected by the user is applied, as shown in FIG. 6A pre-selected the option of ending calls flagged as being from a telemarketer, the call is terminated (either immediately or after a predetermined interval).

[0052] If the user pre-selected the option of sending flagged calls to voicemail, the pre-recorded message addressed to telemarketers is played to the caller (as illustrated in FIG. 6C). The caller is then presented with the option of pressing "1" to record a voice message to the recipient or pressing "2" to end the call. If the caller enters "1", they are put on hold for an interval proportional to the greylist score (sometimes known as "tarpitting") before being forwarded to the user's voicemail service. If the caller pressed "2", the call is terminated immediately.

[0053] If the user pre-selected the option of accepting telemarketing calls (the default setting illustrated in FIG. 6D), the pre-recorded message addressed to telemarketers is played to the caller, then the caller will be presented with the option of pressing "1" to proceed with the call or pressing "2" to end the call. If the caller enters "1", they are put on hold for a period of time proportional to the greylist score before being passed through to the user as a conventional call. If no message has been recorded by the caller, the call is terminated. If "2" is selected, the call is terminated.

[0054] If the user pre-selected the option of requesting that a greylist caller announce themselves (as illustrated in FIG. 6B), a pre-recorded message will be played to the caller giving the caller the option of pressing "1" to leave a message announcing their identity for the recipient, or pressing "2" to end the call. If the user presses "1" they will be prompted to record a message. The screening system will then call the subscriber and play the recorded message, optionally identifying the caller as a potential telemarketer. If the call is not answered, the call will continue as a conventional call, perhaps being redirected to the user's voicemail system. If the call is answered, the user will then be given the option to press "1" to receive the call, press "2" to forward the call to voicemail, press "3" to terminate the call, or press "4" to play a pre-recorded message that the user does not accept telemarketing calls and then terminate the call.

[0055] A similar process as shown in FIGS. 5 and 6 may be used for incoming text messages as indicated in FIG. 7. The originating number of the message is checked if it is valid, then the number is looked up the recipient's number in the client database and retrieves the user's settings. If the recipient

is not using the system or does not have the screening service enabled, the incoming text message is passed through to the recipient.

[0056] If the originating number of message is on the global whitelist or the recipient's whitelist, the message is passed through to the recipient. If the originating number is on the user's blacklist, the selected message treatment is applied to the message as discussed above with regards to FIGS. 8A, 8B, 8C, and 8D. If the originating number appears on the greylist and has a score below the level of tolerance selected by the subscriber, the message is routed to the recipient as a conventional message. If the score for the originating number is equal to or above the level of tolerance selected by the user, the call is flagged and the treatment selected by the user is applied.

[0057] Internet telephony subscribers may have the option of accessing their call screen management tool via the service provider's website. Similar settings can be presented through that medium.

[0058] In a further embodiment of the invention, all originating numbers are maintained in the greylist with a default screening value, and the screening value of a particular originating number is modified as data relating to the originating number is received from subscribers.

[0059] Various embodiments of the present invention having been thus described in detail by way of example, it will be apparent to those skilled in the art that variations and modifications may be made without departing from the invention.

What is claimed is:

1. A method of screening incoming communications originating at originating number, comprising the steps of:
 - a. maintaining a screening list of originating numbers assigned to suspect originators;
 - b. storing one or more rules defining when an originator's assigned originating number will be added to or removed from the screening list, or modifying a screening value to be assigned to the originator's assigned originating number on the screening list, or both;
 - c. receiving data relating to suspect originators;
 - d. applying the one or more rules to the data;
 - e. adding to or removing from the screening list the originator's assigned originating number, or modifying the screening value assigned to the originator's assigned originating number, or both, based on the application of the one or more rules to the data; and
 - f. screening an incoming communication from the sender's assigned originating number to a recipient in accordance with one or more rules based on the originator's assigned originating number being in the screening list or on the screening value assigned to the originator's assigned originating number, or both.
2. The method of claim 1 wherein step f. comprises the sub-step of establishing a recipient tolerance level based on the screening value.
3. The method of claim 2 wherein one of a plurality of options for blocking, allowing or confirming the incoming communication is performed based on the recipient tolerance level.
4. The method of claim 1 comprising, at any time, the step of a recipient assigning an originator's assigned originating number to a blocked sender list or to a list of acceptable senders.

5. The method of claim 1 wherein some or all of the data is received from recipients relating to incoming communications messages received by the recipients

6. The method of claim 1 wherein some or all of the data is received from an administrator of the system.

7. A system for screening incoming communications to a recipient telephone number, comprising

at least one database, for maintaining a screening list of telephone numbers assigned to suspect communication originators and one or more rules defining when an originator's assigned telephone number will be added to or removed from the screening list, or modifying a screening value to be assigned to an originator's assigned telephone number on the screening list, or both; and

a data processing device, for receiving data relating to suspect originators and applying the one or more rules to the data,

adding to or removing from the screening list the originator's assigned telephone number, or modifying the screening value assigned to the originator's assigned telephone number, or both, based on the application of the one or more rules to the data; and

screening a text message from the originator's assigned telephone number to a recipient in accordance with one or more rules, based on the originator's assigned telephone number being in the screening list or on the screening value assigned to the originator's assigned telephone number, or both.

8. The system of claim 7 wherein the data processing device screens an incoming communication from the originator's assigned telephone number to a recipient based on the screening value.

9. The system of claim 8 wherein the data processing device screens an incoming communication from the originator's assigned telephone number to a recipient based on a preset recipient tolerance level.

10. The system of claim 7 wherein the recipient can assign an originator's assigned telephone number to a blocked sender list or to a list of acceptable originators.

11. The system of claim 7 wherein some or all of the data is received from recipients relating to incoming communications received by the recipients.

12. The system of claim 7 wherein some or all of the data is received from an administrator of the system.

13. A computer program product embodied on a tangible medium for operation on telecommunications hardware for carrying out a method of screening incoming communications, the program product operative to carry out the steps of:

a. maintaining on memory in the telecommunications hardware, a screening list of telephone numbers assigned to suspect communication originators;

b. storing on memory in the telecommunications hardware, one or more rules defining when an originator's assigned telephone number will be added to or removed from the screening list, or modifying a screening value to be assigned to an originator's assigned telephone number on the screening list, or both;

c. receiving data relating to suspect originators;

d. applying the one or more rules to the data;

e. adding to or removing from the screening list the originator's assigned telephone number, or modifying the screening value assigned to the originator's assigned telephone number, or both, based on the application of the one or more rules to the data; and

f. screening an incoming communication from the originator's assigned telephone number to a recipient in accordance with one or more rules based on the originator's assigned telephone number being in the screening list or on the screening value assigned to the originator's assigned telephone number, or both.

14. The computer program product of claim 13 wherein step f. comprises the sub-step of establishing a recipient tolerance level based on the screening value.

15. The computer program product of claim 14 wherein one of a plurality of options for blocking, allowing or confirming the incoming communication is performed based on the recipient tolerance level.

16. The computer program product of claim 15 comprising, at any time, the step of assigning a telephone number to a blocked originator list or to a list of acceptable originators based on input by a recipient to the telecommunications hardware.

17. The computer program product of claim 13 wherein some or all of the data is received from recipients relating to incoming communications received by the recipients.

18. The computer program product of claim 13 wherein some or all of the data is received from an administrator of the system.

* * * * *