



US 20080058827A1

(19) **United States**

(12) **Patent Application Publication**
Osorio et al.

(10) **Pub. No.: US 2008/0058827 A1**

(43) **Pub. Date: Mar. 6, 2008**

(54) **METHODS FOR TREATING A FRACTURED AND/OR DISEASED AND/OR WEAKENED BONE**

(75) Inventors: **Reynaldo A. Osorio**, Daly City, CA (US); **Marialulu Follmer**, Sata Clara, CA (US); **Richard W. Layne**, Palo Alto, CA (US); **Ryan P. Boucher**, San Francisco, CA (US); **Karen D. Talmadge**, Palo Alto, CA (US); **Joseph J. Basista**, Mountain View, CA (US)

Correspondence Address:
RYAN KROMHOLZ & MANION, S.C.
Post Office Box 26618
Milwaukee, WI 53226-0618 (US)

(73) Assignee: **Kyphon Inc.**

(21) Appl. No.: **11/789,643**

(22) Filed: **Apr. 25, 2007**

Related U.S. Application Data

(60) Division of application No. 10/783,723, filed on Feb. 20, 2004, which is a division of application No. 09/827,260, filed on Apr. 5, 2001, now Pat. No. 6,726,691.

Said application No. 10/783,723 is a continuation-in-part of application No. 10/346,618, filed on Jan. 17, 2003, which is a division of application No. 09/597,646, filed on Jun. 20, 2000, now Pat. No. 6,716,216, which is a continuation-in-part of application No. 09/134,323, filed on Aug. 14, 1998, now Pat. No. 6,241,734.

Said application No. 09/827,260 is a division of application No. 09/597,646, filed on Jun. 20, 2000, now Pat. No. 6,716,216, which is a continuation-in-

part of application No. 09/134,323, filed on Aug. 14, 1998, now Pat. No. 6,241,734.

Continuation-in-part of application No. 10/958,600, filed on Oct. 5, 2004, which is a division of application No. 09/754,451, filed on Jan. 4, 2001, now Pat. No. 6,899,719, which is a continuation of application No. 08/871,114, filed on Jun. 9, 1997, now Pat. No. 6,248,110, which is a continuation-in-part of application No. 08/659,678, filed on Jun. 5, 1996, now Pat. No. 5,827,289, which is a continuation-in-part of application No. 08/485,394, filed on Jun. 7, 1995, now abandoned, which is a continuation-in-part of application No. 08/188,224, filed on Jan. 26, 1994, now abandoned.

(60) Provisional application No. 60/194,685, filed on Apr. 5, 2000.

Publication Classification

(51) **Int. Cl.**
A61B 17/88 (2006.01)
(52) **U.S. Cl.** **606/94; 606/92; 606/93**

(57) **ABSTRACT**

An elongated shaft is sized and configured to establish an access path to bone having an interior volume occupied, at least in part, by cancellous bone. The elongated shaft includes a distal end portion having a side opening. A first tool is sized and configured to be carried by the shaft and includes a region that is capable of being controllably advanced by a user through the side opening to project outside the distal end portion and contact cancellous bone. Contact between the region and cancellous bone can modify cancellous bone for introduction of bone filling material, e.g., by creating at least one flow path for the bone filling material.

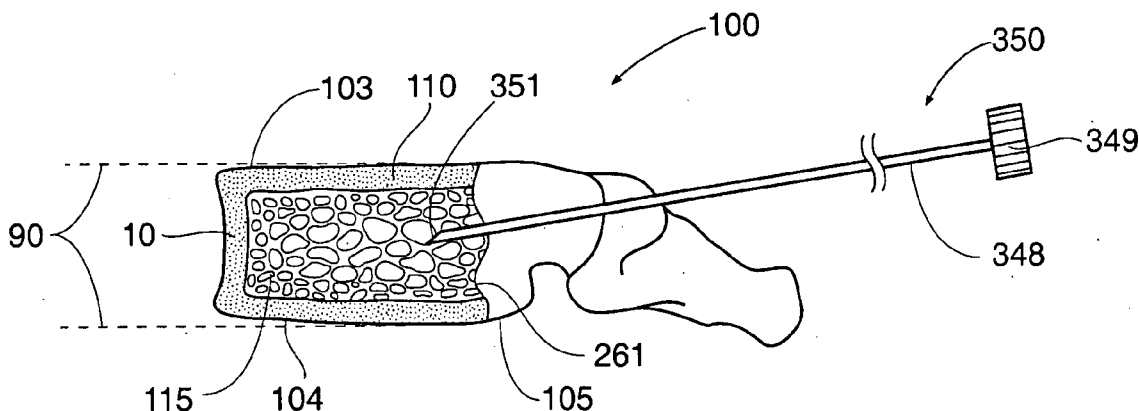

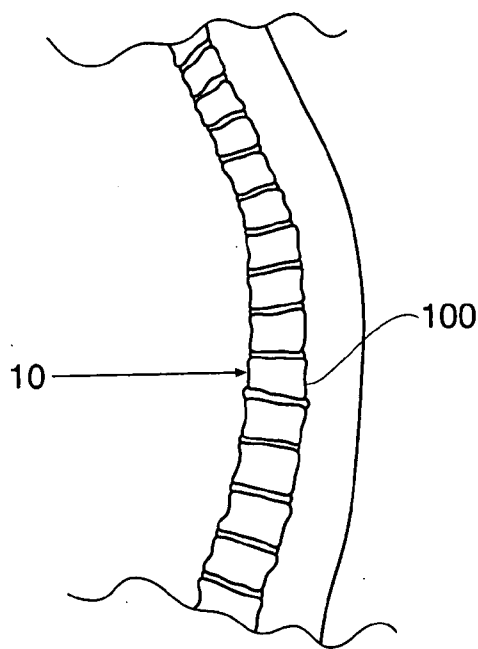

Fig. 1

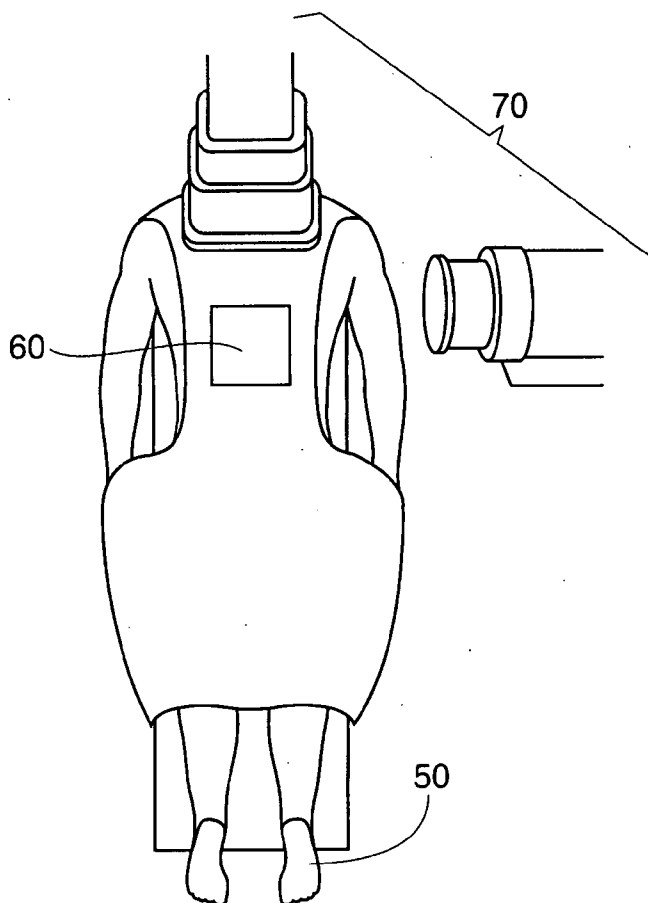

Fig. 2

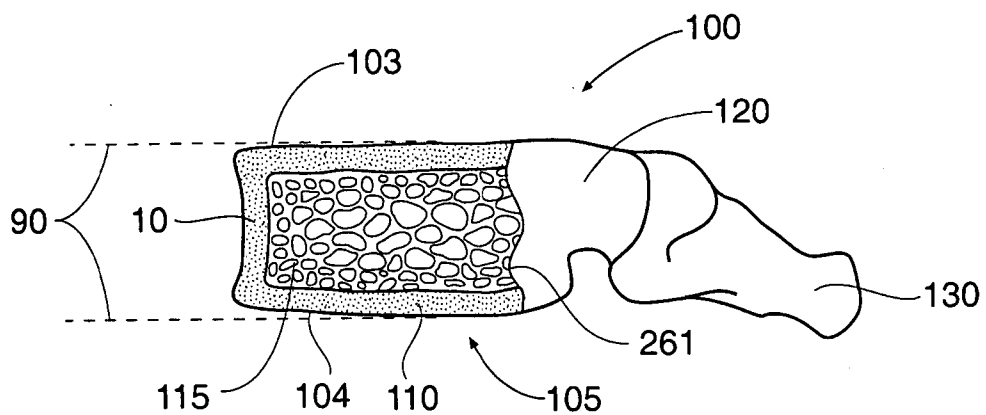

Fig. 3

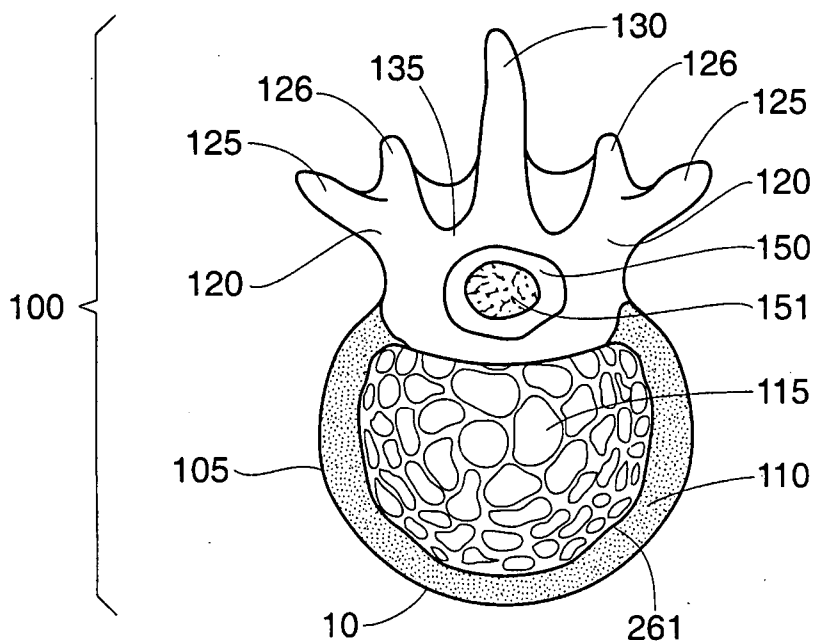

Fig. 4

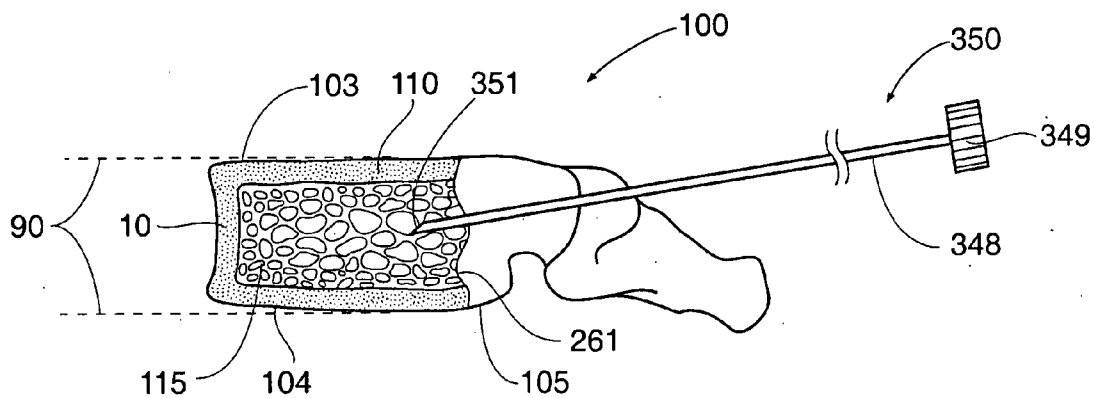

Fig. 5a

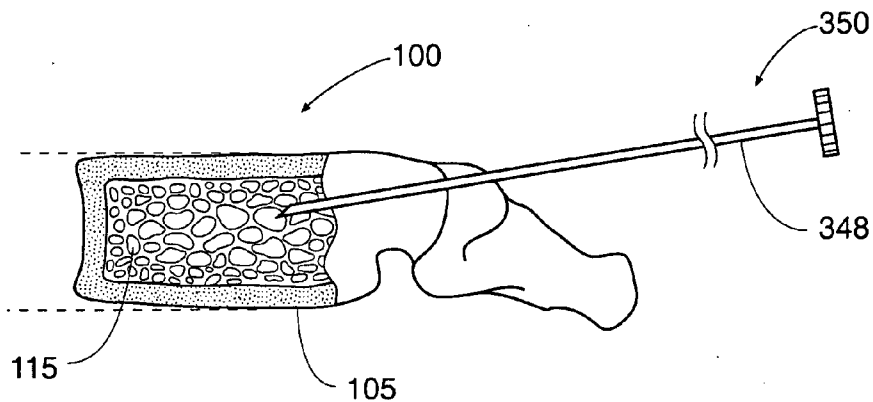

Fig. 5b

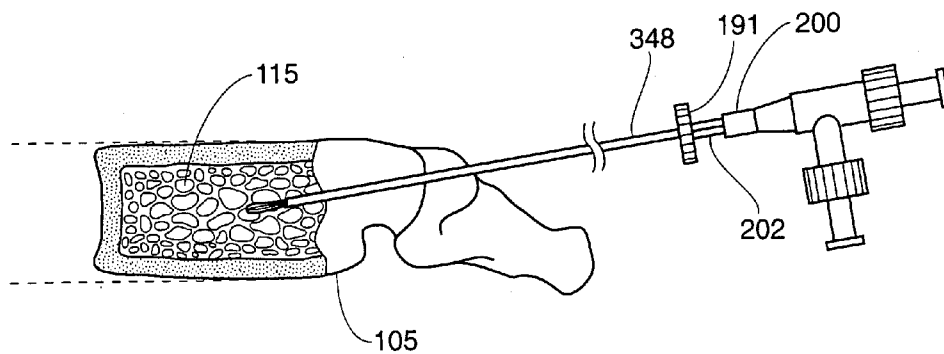

Fig. 5c

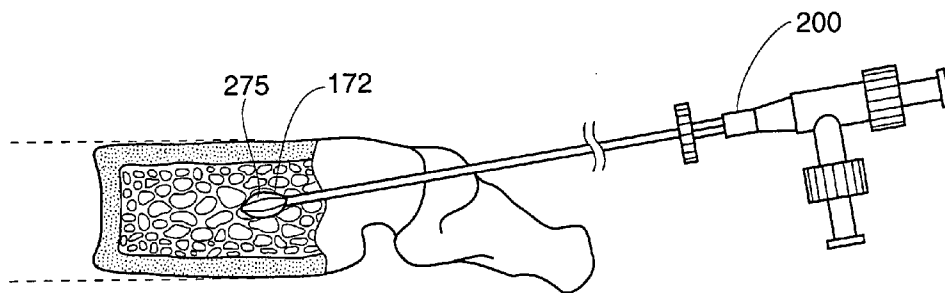

Fig. 5d

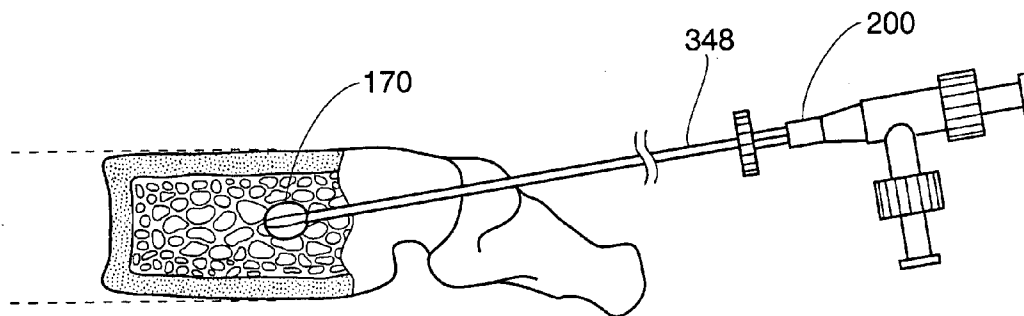

Fig. 5e

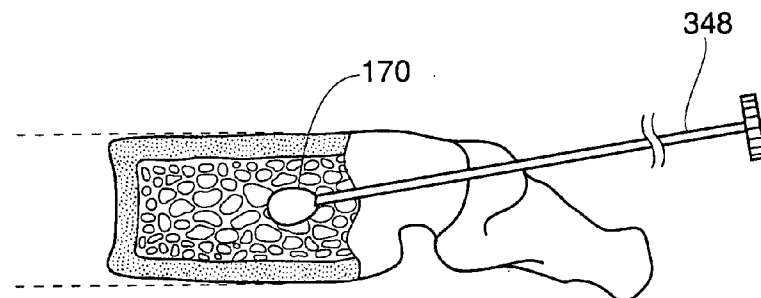

Fig. 5f

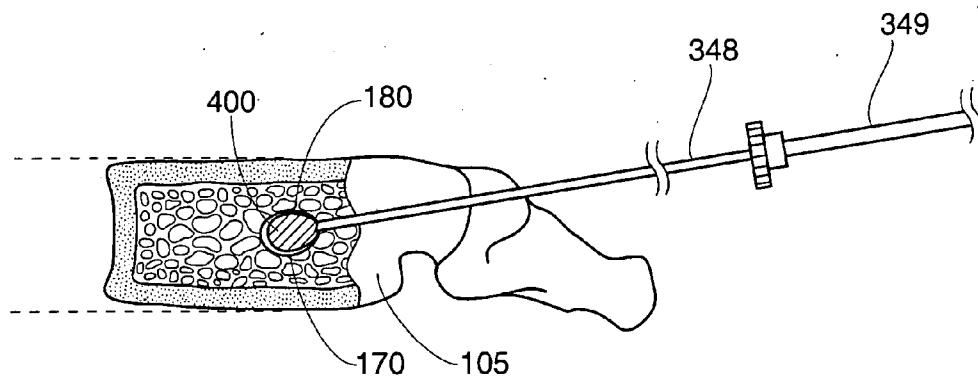

Fig. 5g

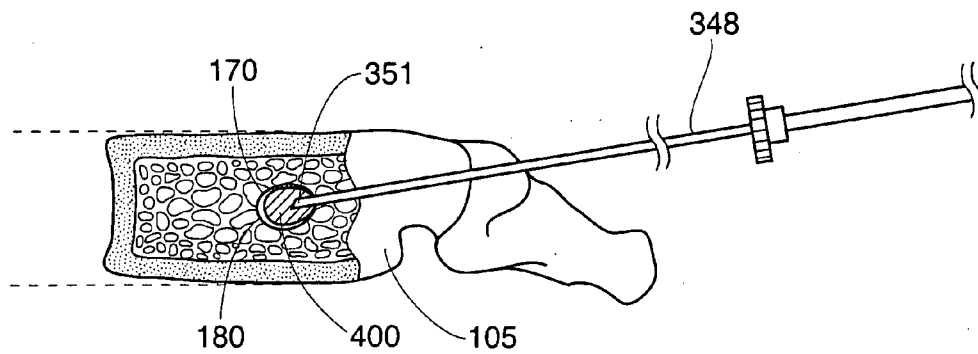

Fig. 5h

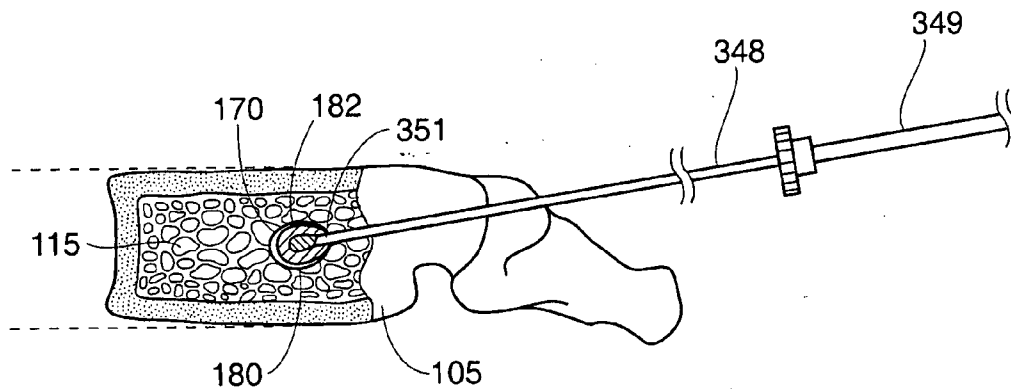

Fig. 5i

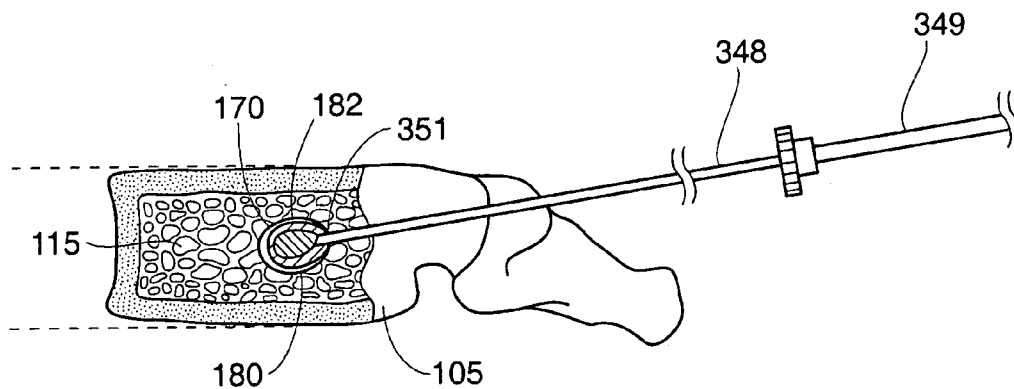

Fig. 5j

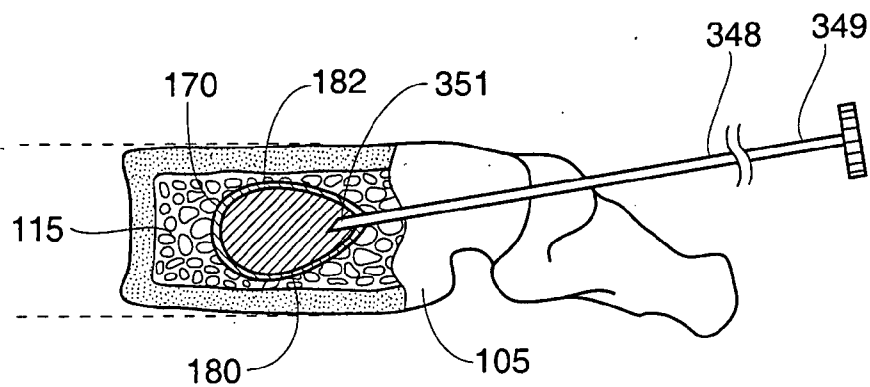

Fig. 5k

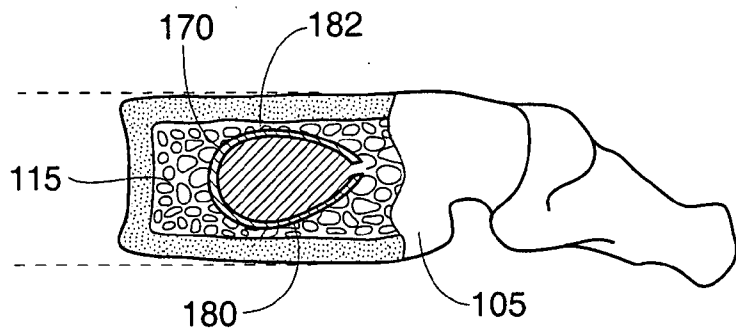

Fig. 5l

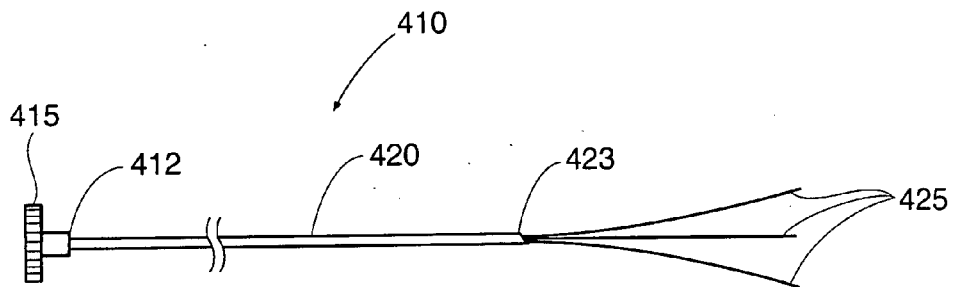

Fig. 6a

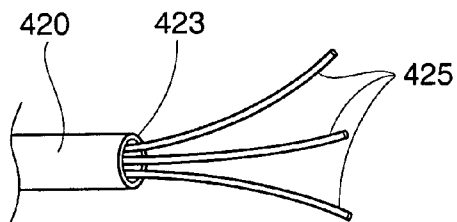

Fig. 6b

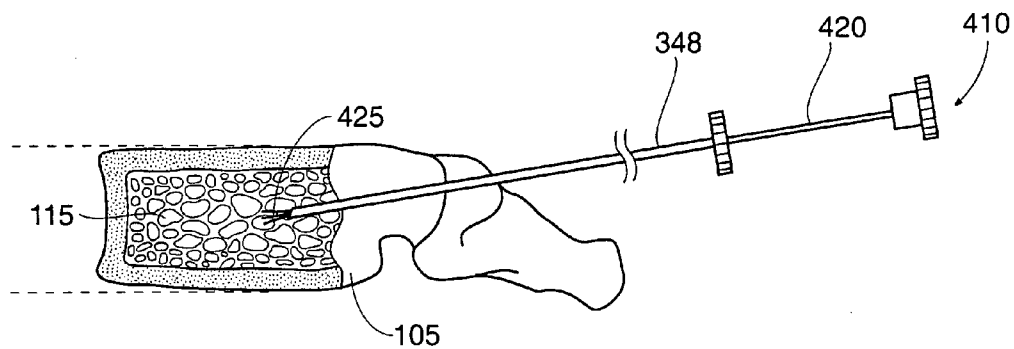

Fig. 7a

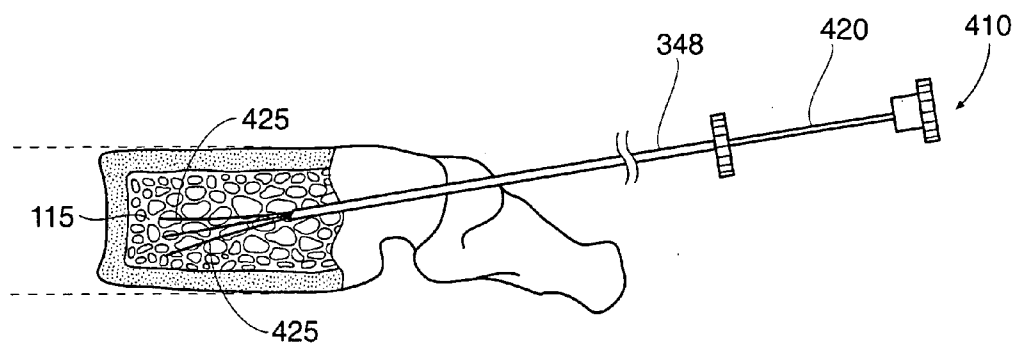

Fig. 7b

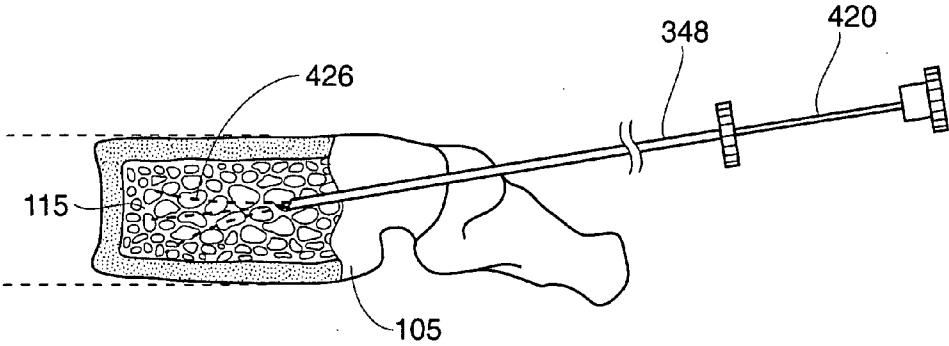
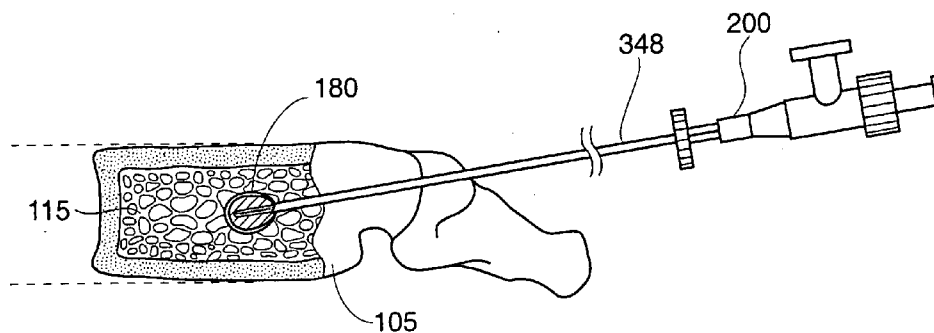
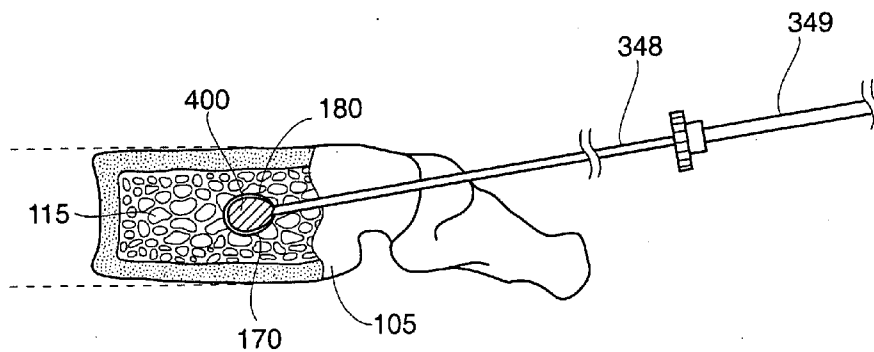

Fig. 7c



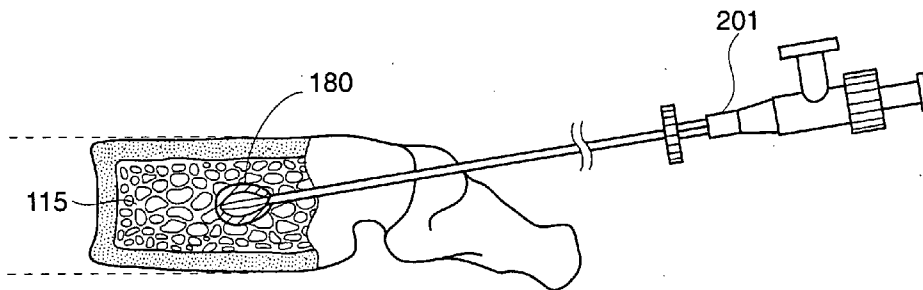
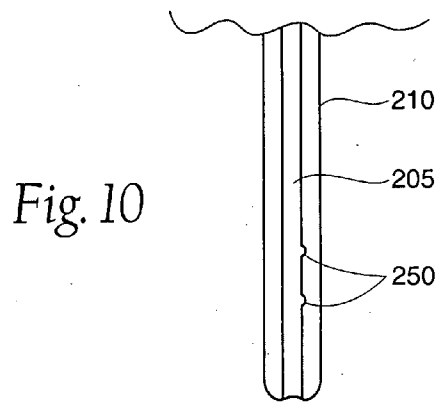
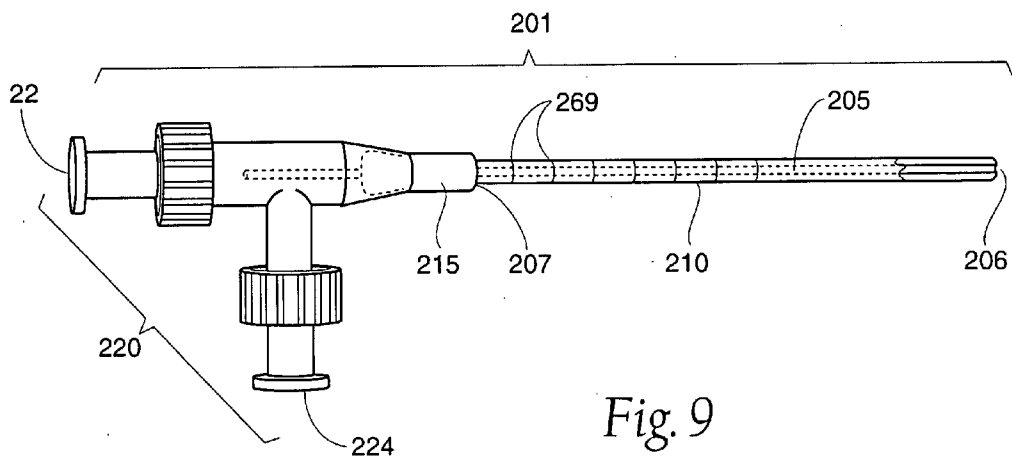

Fig. 8c



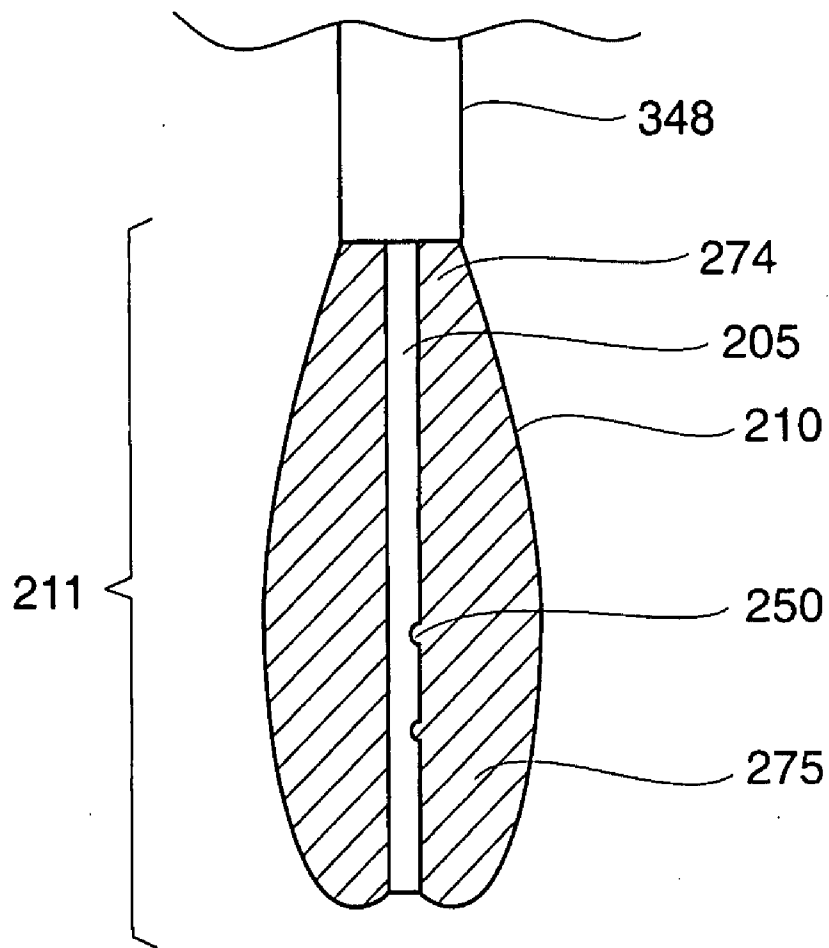

Fig. 11

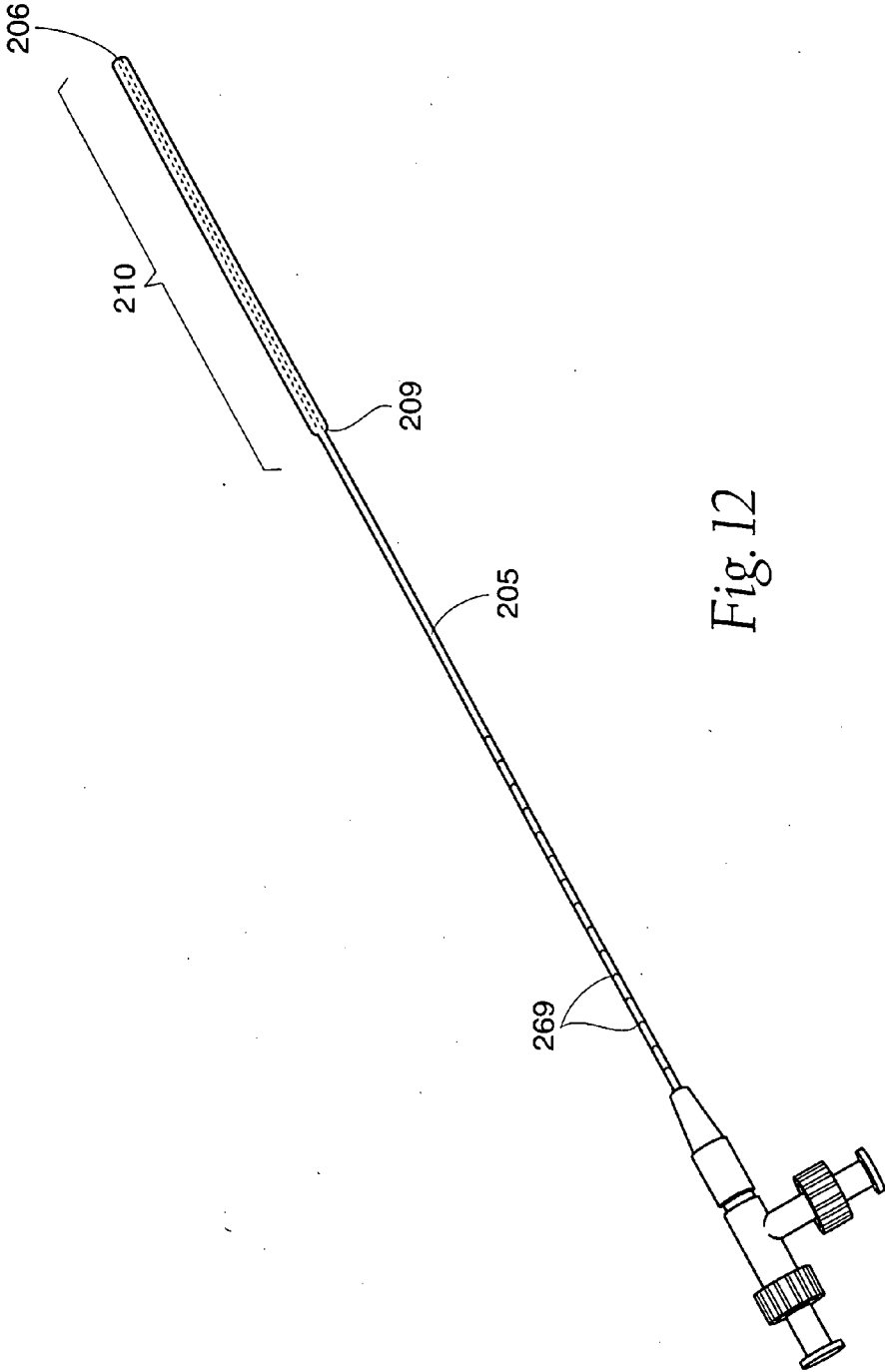

Fig. 12

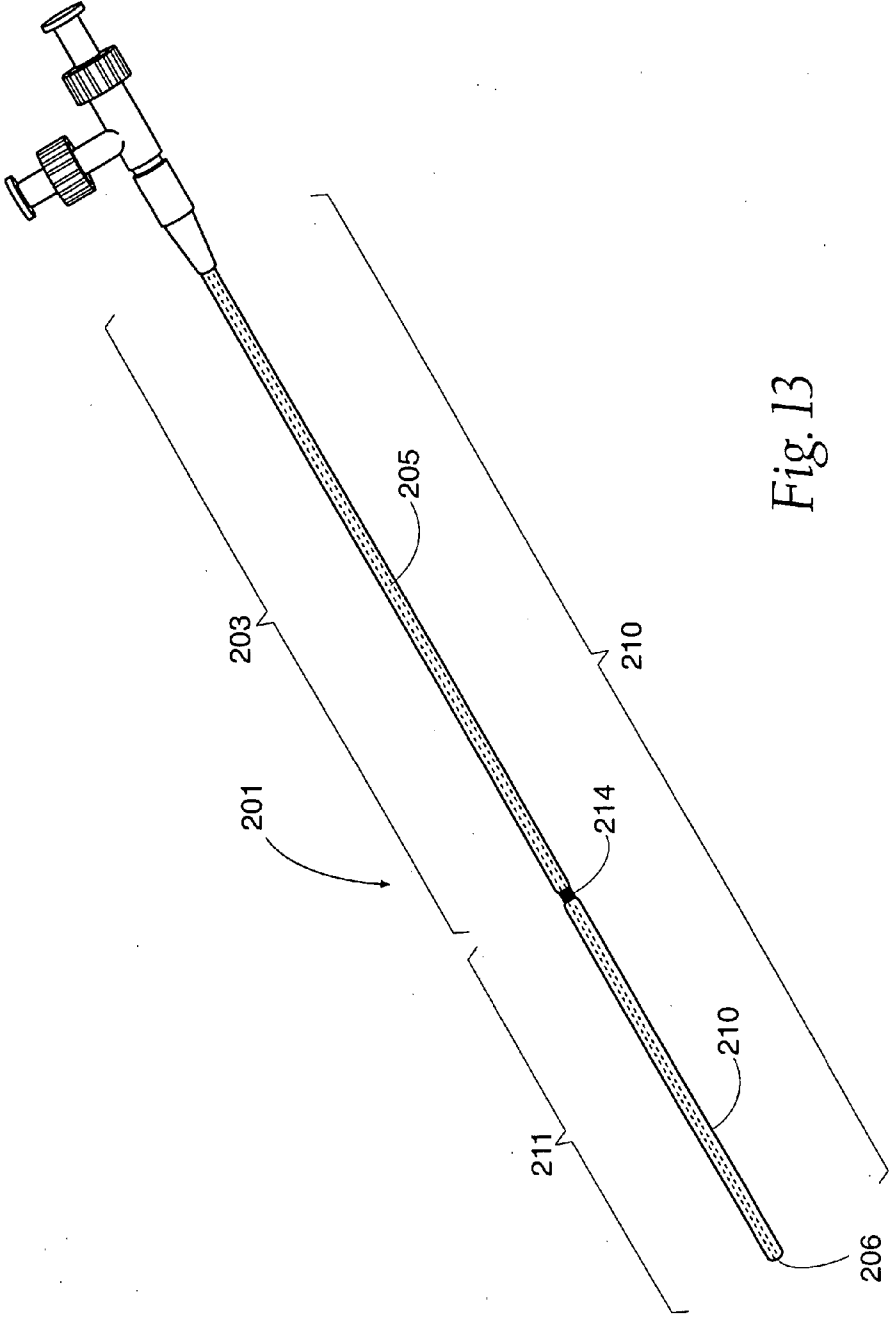

Fig. 13

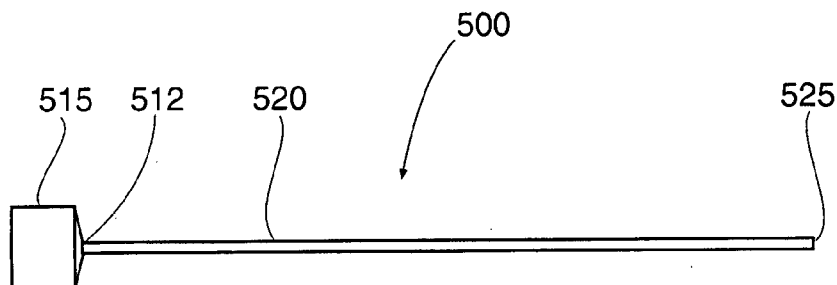

Fig. 14

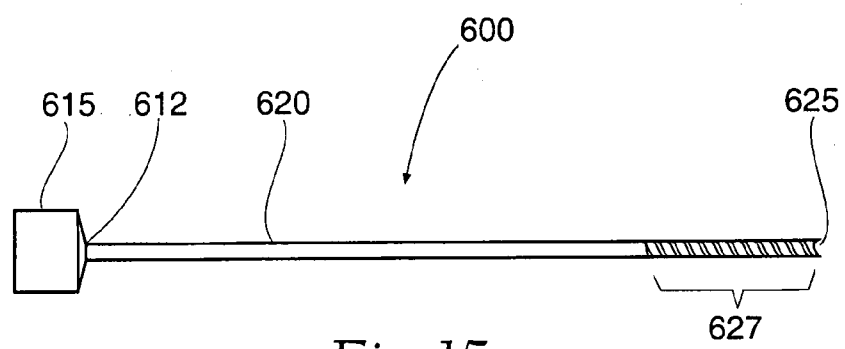

Fig. 15

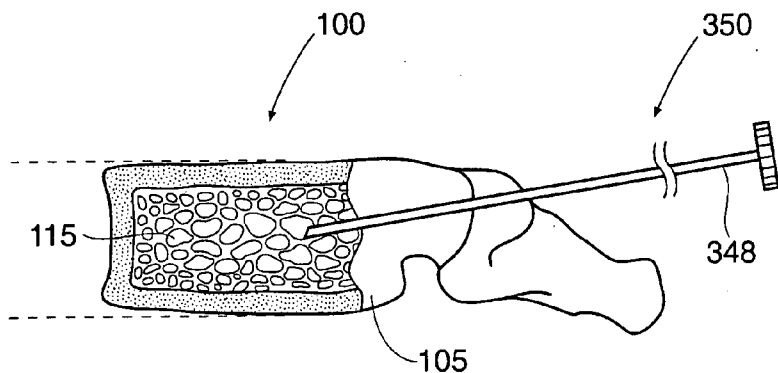

Fig. 16a

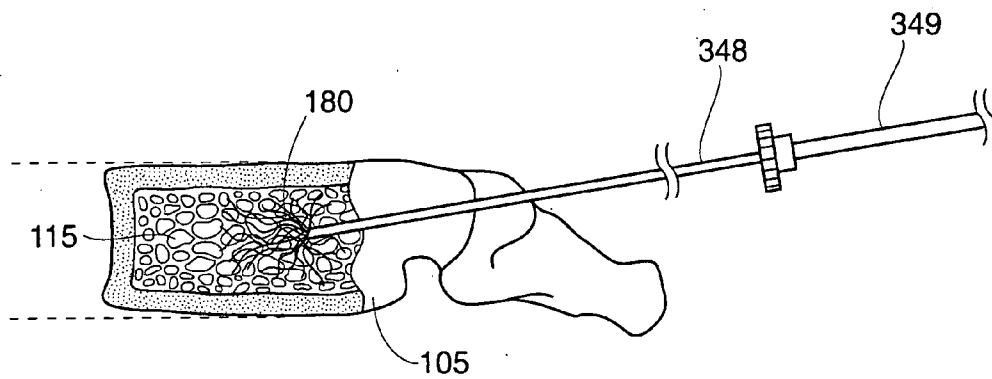

Fig. 16b

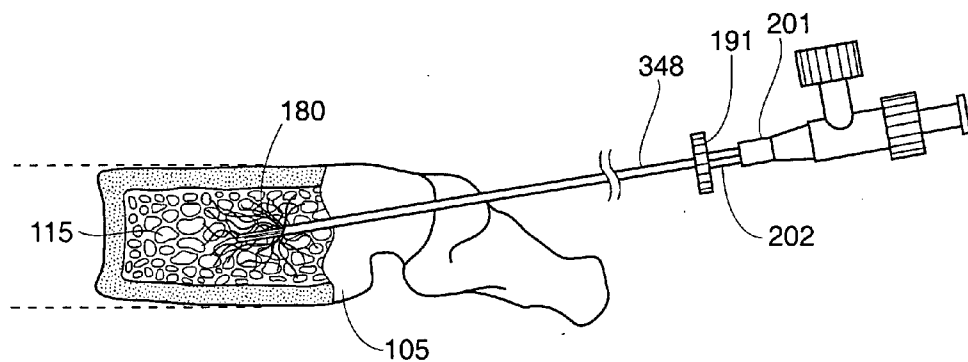

Fig. 16c

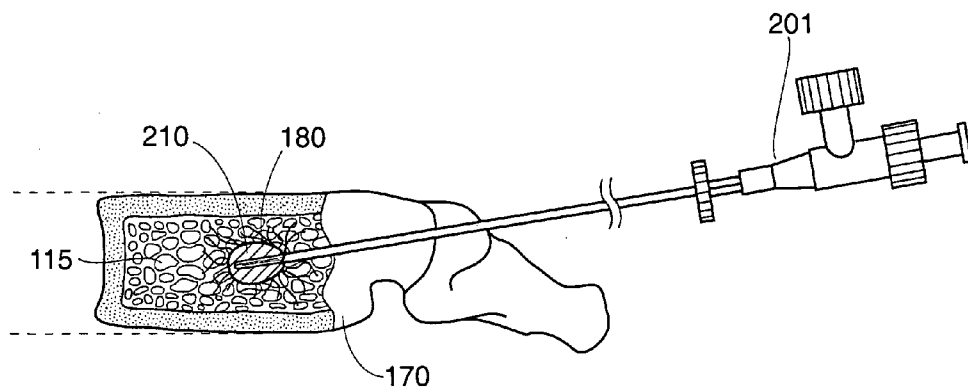

Fig. 16d

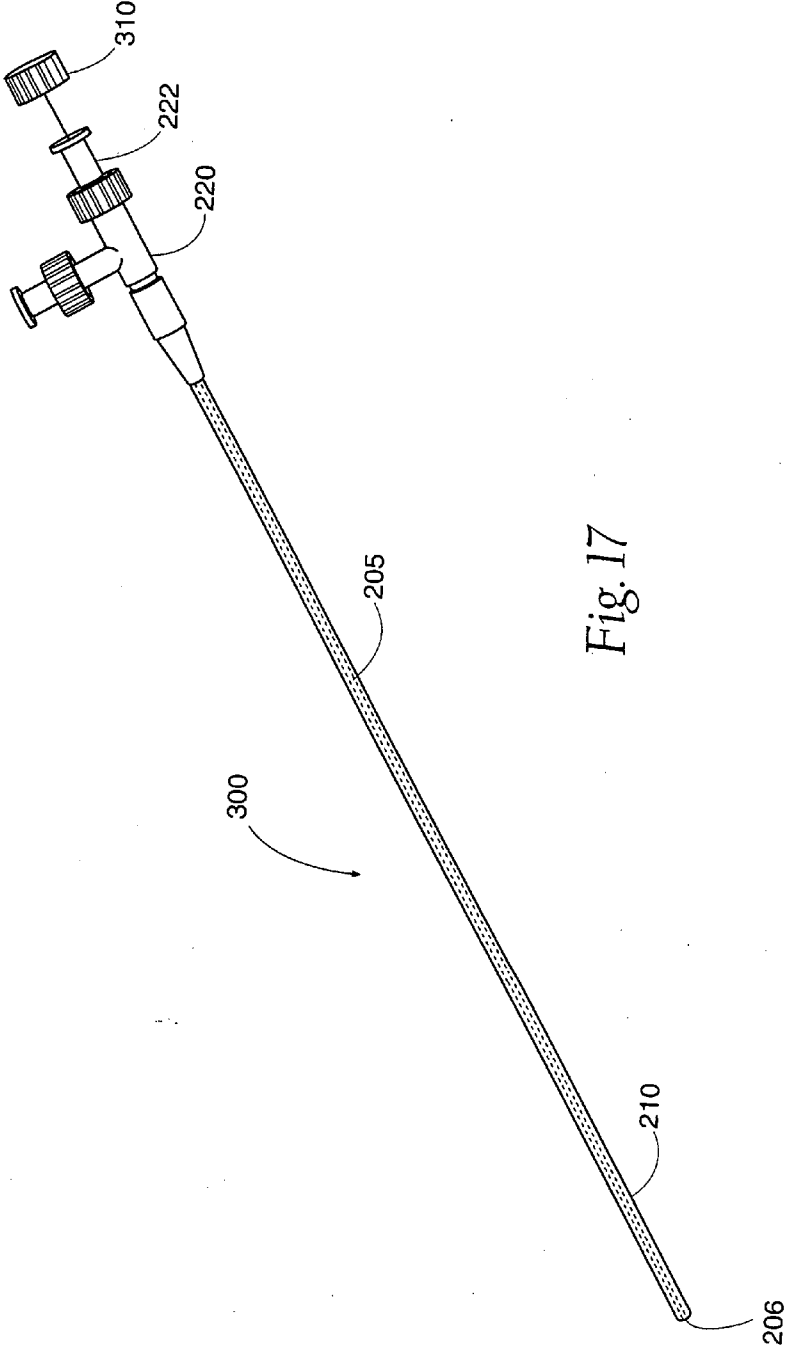

Fig. 17

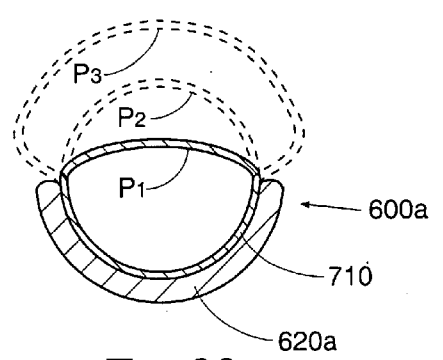
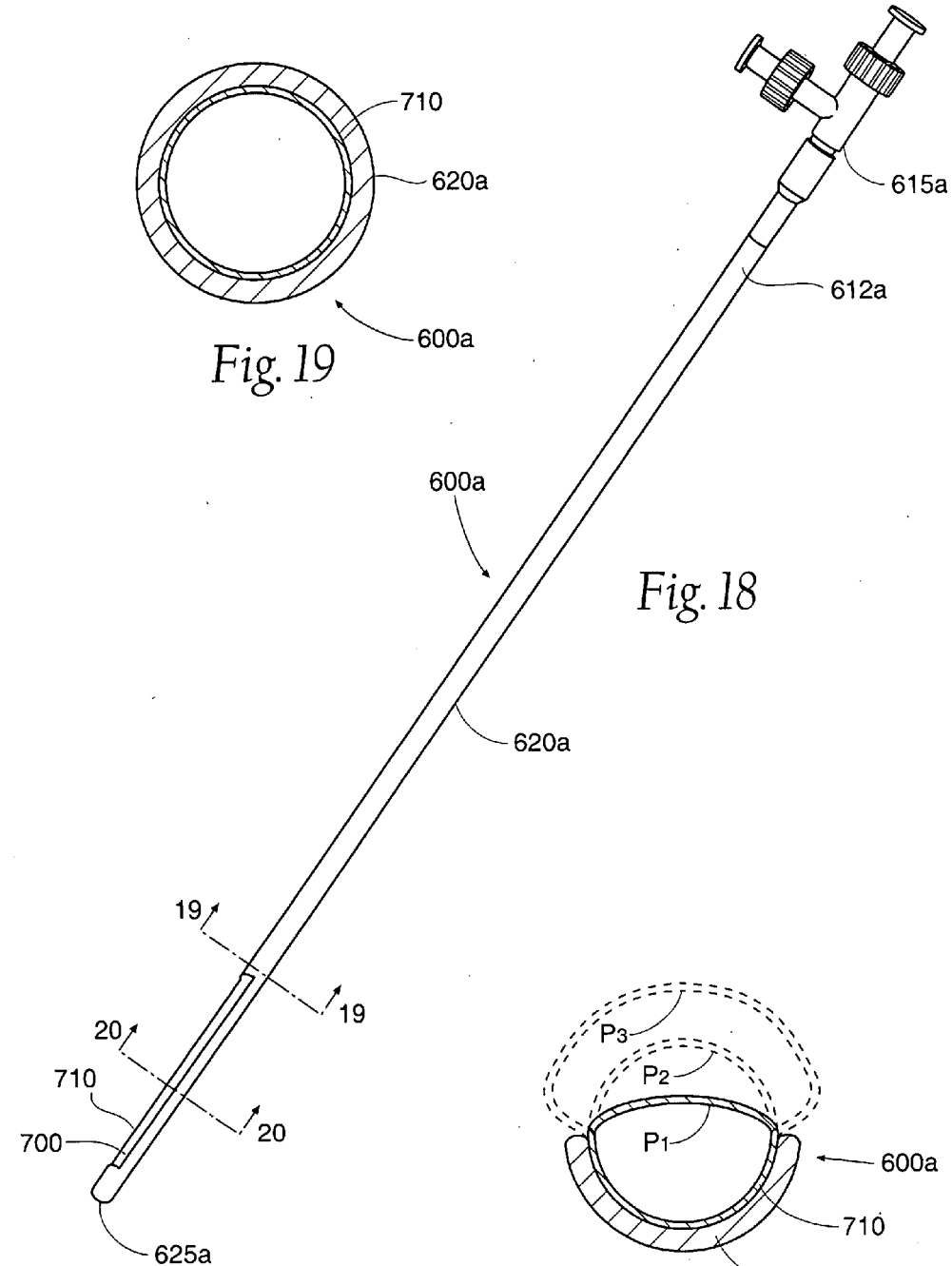
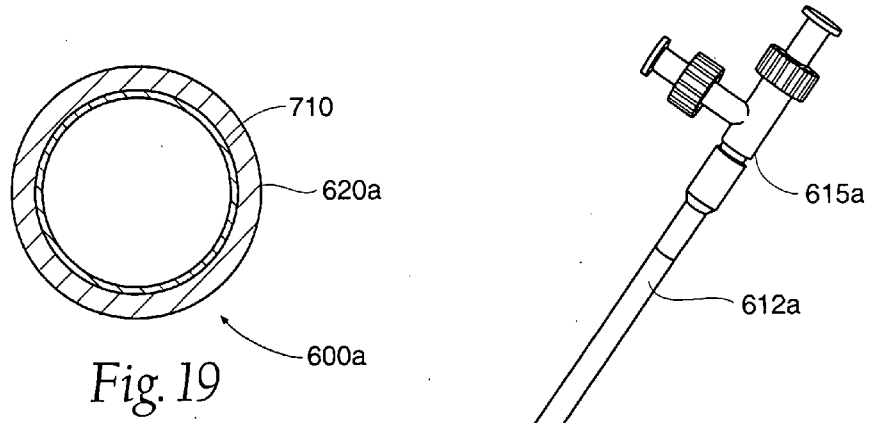

Fig. 19

Fig. 18

Fig. 20

METHODS FOR TREATING A FRACTURED AND/OR DISEASED AND/OR WEAKENED BONE

RELATED APPLICATIONS

[0001] This application is a divisional of co-pending U.S. patent application Ser. No. 10/783,723, filed 20 Feb. 2004, and entitled "Methods and Devices for Treating Fractured and/or Diseased Bone," which is a divisional of U.S. patent application Ser. No. 09/827,260, filed 5 Apr. 2001 (now U.S. Pat. No. 6,726,691), which claims the benefit of U.S. Provisional Patent Application No. 60/194,685, filed 5 Apr. 2000 (Expired), and which is also a continuation-in-part of co-pending U.S. patent application Ser. No. 10/346,618, filed 17 Jan. 2003, which is a divisional of U.S. patent application Ser. No. 09/597,646, filed 20 Jun. 2000 (now U.S. Pat. No. 6,716,216), which is a continuation-in-part of U.S. patent application Ser. No. 09/134,323, filed 14 Aug. 1998 (now U.S. Pat. No. 6,241,734), each of which is incorporated herein by reference. This application is also a continuation-in-part of co-pending U.S. patent application Ser. No. 10/958,600, filed 5 Oct., 2004, and entitled "Systems and Methods for Treating Fractured or Diseased Bone Using Expandable Bodies," which is a divisional of U.S. patent application Ser. No. 09/754,451, filed 4 Jan. 2001 (now U.S. Pat. No. 6,899,719), which is a continuation of U.S. patent application Ser. No. 08/871,114, filed 9 Jun. 1997 (now U.S. Pat. No. 6,248,110), which is a continuation-in-part of U.S. patent application Ser. No. 08/659,678, filed 5 Jun. 1996 (now U.S. Pat. No. 5,827,289), which is a continuation-in-part of U.S. patent application Ser. No. 08/485,394, filed 7 Jun. 1995 (Abandoned), which is a continuation-in-part of U.S. patent application Ser. No. 08/188,224, filed 26 Jan. 1994 (Abandoned), each of which is incorporated herein by reference.

BACKGROUND OF THE INVENTION

[0002] 1. Field of the Invention

[0003] The present invention relates to devices and methods for treating fractured and/or diseased bone. More specifically, the present invention relates to devices and methods for repairing, reinforcing and/or treating fractured and/or diseased bone using various devices, including cavity-forming devices.

[0004] 2. DESCRIPTION OF THE BACKGROUND

[0005] Normal healthy bone is composed of a framework made of proteins, collagen and calcium salts. Healthy bone is typically strong enough to withstand the various stresses experienced by an individual during his or her normal daily activities, and can normally withstand much greater stresses for varying lengths of time before failing. However, osteoporosis or a host of other diseases, including such diseases as breast cancer, hemangiomas, osteolytic metastases or spinal myeloma lesions, as well as the long term excessive use of alcohol, tobacco and/or various drugs, can affect and significantly weaken healthy bone over time. If unchecked, such factors can degrade bone strength to a point where the bone is especially prone to fracture, collapse and/or is unable to withstand even normal daily stresses.

[0006] Unfortunately, losses in bone strength are often difficult to discover until bone integrity has already been seriously compromised. For instance, the effects of

osteoporosis are often not discovered until after a bone fracture has already occurred, at which time much of the patient's overall bone strength has typically weakened to dangerous levels. Moreover, as most bone development occurs primarily during childhood and early adulthood, long-term losses in bone strength are typically irreversible. In addition, many bone diseases, including osteoporosis, cancer, and other bone-related disorders, are not routinely curable at our current stage of medical development.

[0007] For many individuals in our aging world population, undiagnosed and/or untreatable bone strength losses have already weakened these individuals' bones to a point that even normal daily activities pose a significant threat of fracture. For example, when the bones of the spine are sufficiently weakened, the compressive forces in the spine can often cause fracture and/or deformation of the vertebral bodies. For sufficiently weakened bone, even normal daily activities like walking down steps or carrying groceries can cause a collapse of one or more spinal bones, much like a piece of chalk collapses under the compressive weight of a human foot. A fracture of the vertebral body in this manner is typically referred to as a vertebral compression fracture. Researchers estimate that at least 25 percent of all women, and a somewhat smaller percentage of men, over the age of 50 will suffer one or more vertebral compression fractures due to osteoporosis alone. In the United States, it is estimated that over 700,000 vertebral compression fractures occur each year, over 200,000 of which require some form of hospitalization. Other commonly occurring fractures resulting from weakened bones can include hip, wrist, knee and ankle fractures, to name a few.

[0008] Fractures such as vertebral compression fractures often result in episodes of pain that are chronic and intense. Aside from the pain caused by the fracture itself, the involvement of the spinal column can result in pinched and/or damaged nerves, causing paralysis, loss of function, and intense pain which radiates throughout the patient's body. Even where nerves are not affected, however, the intense pain associated with all types of fractures is debilitating, resulting in a great deal of stress, impaired mobility and other long-term consequences. For example, progressive spinal fractures can, over time, cause serious deformation of the spine ("kyphosis"), giving an individual a hunched-back appearance, and can also result in significantly reduced lung capacity and increased mortality.

[0009] Until recently, treatment options for vertebral compression fractures, as well as other serious fractures and/or losses in bone strength, were extremely limited—mainly pain management with strong oral or intravenous medications, reduced activity, bracing and/or radiation therapy, all with mediocre results. Because patients with these problems are typically older, and often suffer from various other significant health complications, many of these individuals are unable to tolerate invasive surgery. In addition, to curb further loss of bone strength, many patients are given hormones and/or vitamin/mineral supplements—again with mediocre results and often with significant side effects.

[0010] Over the past decade, a technique called vertebroplasty has been introduced into the United States. Vertebroplasty involves the injection of a flowable reinforcing material, usually polymethylmethacrylate (PMMA—commonly known as bone cement), into a fractured, weakened, or

diseased vertebral body. Shortly after injection, the liquid filling material hardens or polymerizes, desirably supporting the vertebral body internally, alleviating pain and preventing further collapse of the injected vertebral body.

[0011] While vertebroplasty has been shown to reduce some pain associated with vertebral compression fractures, this procedure has certain inherent drawbacks. The most significant danger associated with vertebroplasty is the inability of the practitioner to control the flow of liquid bone cement during injection into a vertebral body. Although the location and flow patterns of the cement can be monitored by CT scanning or x-ray fluoroscopy, once the liquid cement exits the injection needle, it naturally follows the path of least resistance within the bone, which is often through the cracks and/or gaps in the cancellous and/or cortical bone. Moreover, because the cancellous bone resists the injection of the bone cement and small diameter needles are typically used in vertebroplasty procedures, extremely high pressures are required to force the bone cement through the needle and into the vertebral body. Bone cement, which is viscous, is difficult to inject through small diameter needles, and thus many practitioners choose to “thin out” the cement mixture to improve cement injection, which ultimately exacerbates the leakage problems. In a recent study where 37 patients with bone metastases or multiple myeloma were treated with vertebroplasty, 72.5% of the procedures resulted in leakage of the cement outside the vertebral body. Cortet B. et al., *Percutaneous Vertebroplasty in Patients With Osteolytic Metastases or Multiple Myeloma* (1998). Moreover, where the practitioner attempts to “thin out” the cement by adding additional liquid monomer to the cement mix, the amount of unpolymerized or “free” monomer increases, which can ultimately be toxic to the patient.

[0012] Another drawback of vertebroplasty is due to the inability to visualize (using CT scanning or x-ray fluoroscopy) the various venous and other soft tissue structures existent within the vertebra. While the position of the needle within the vertebral body is typically visualized, the location of the venous structures within the vertebral body are not. Accordingly, a small diameter vertebroplasty needle can easily be accidentally positioned within a vein in the vertebral body, and liquid cement pumped directly into the venous system, where the cement easily passes out the anterior and/or posterior walls of the vertebrae through the anterior external venous plexus or the basivertebral vein.

[0013] Another significant drawback inherent in vertebroplasty is the inability of this procedure to restore the vertebral body to a pre-fractured condition prior to the injection of the reinforcing material. Because the bone is fractured and/or deformed, and not repositioned prior to the injection of cement, vertebroplasty essentially “freezes” the bone in its fractured condition. Moreover, it is highly unlikely that a traditional vertebroplasty procedure could be capable of restoring significant pre-fracture anatomy—because bone cement flows towards the path of least resistance, any en-masse movement of the cortical bone would likely create gaps in the interior and/or walls of the vertebral body through which the bone cement would then immediately flow.

[0014] A more recently developed procedure for treating fractures such as vertebral compression fractures and other bone-related disorders is known as Kyphoplasty™. See, for

example, U.S. Pat. Nos. 4,969,888 and 5,108,404. In Kyphoplasty, an expandable body is inserted through a small opening in the fractured or weakened bone, and then expanded within the bone. This procedure compresses the cancellous bone, and desirably moves the fractured bone to its pre-fractured orientation, creating a cavity within the bone that can be filled with a settable material such as cement or any number of synthetic bone substitutes. In effect, the procedure “sets” the bone at or near its pre-fracture position and creates an internal “cast,” protecting the bone from further fracture and/or collapse. This procedure is of course suitable for use in various other bones as well.

[0015] While Kyphoplasty can restore bones to a pre-fractured condition, and injected bone filler is less likely to leak out of the vertebral body during a Kyphoplasty procedure, Kyphoplasty requires a greater number of surgical tools than a vertebroplasty procedure, at an increased cost. Moreover, Kyphoplasty tools are typically larger in diameter than vertebroplasty tools, and thus require larger incisions and are generally more invasive.

SUMMARY OF THE INVENTION

[0016] The present invention overcomes many of the problems and disadvantages associated with current strategies and designs in medical procedures to repair, reinforce and/or treat weakened, diseased and/or fractured bone.

[0017] One aspect of the invention provides a system comprising an elongated shaft that is sized and configured to establish an access path to bone having an interior volume occupied, at least in part, by cancellous bone. The elongated shaft includes a distal end portion having a side opening. The system also includes a first tool that is sized and configured to be carried by the shaft. The first tool includes a region that is capable of being controllably advanced by a user through the side opening to project outside the distal end portion and contact cancellous bone.

[0018] In one embodiment, contact between the region and cancellous bone modifies cancellous bone for introduction of bone filling material.

[0019] In one embodiment, contact between the region and cancellous bone creates at least one flow path for bone filling material.

[0020] In one embodiment, the system includes a second tool to convey a volume of bone filling material into cancellous bone contacted by the region. The bone filling material can comprise, e.g., bone cement.

[0021] Another aspect of the invention provides a method comprising establishing an access path to bone having an interior volume occupied, at least in part, by cancellous bone by placing within the cancellous bone an elongated shaft including a distal end portion having a side opening. The method modifies cancellous bone for introduction of bone filling material by advancing a tool through the side opening to project outside the distal end portion to contact cancellous bone.

[0022] In one embodiment, the method conveys bone filling material into cancellous bone contacted by the tool.

[0023] Another aspect of the invention provides a method comprising establishing an access path to bone having an

interior volume occupied, at least in part, by cancellous bone by placing within the cancellous bone an elongated shaft including a distal end portion having a side opening. The method creates at least one flow path for a bone filling material in the cancellous bone by advancing a tool through the side opening to project outside the distal end portion to contact cancellous bone.

[0024] In one embodiment, the method conveys bone filling material into cancellous bone contacted by the tool.

[0025] The bone can comprise, e.g., a vertebral body.

[0026] Other objects, advantages, and embodiments of the invention are set forth in part in the description which follows, and in part, will be obvious from this description, or may be learned from the practice of the invention.

BRIEF DESCRIPTION OF THE DRAWINGS

[0027] FIG. 1 is a diagram of a spine with a compression fracture in one vertebrae;

[0028] FIG. 2 is a diagram of a patient about to undergo surgery;

[0029] FIG. 3 is a lateral view, partially broken away and in section, of a lumbar vertebra depicting a compression fracture;

[0030] FIG. 4 is a coronal view of a lumbar vertebra;

[0031] FIG. 5A is a lateral view of a lumbar vertebra depicting a spinal needle inserted into the vertebral body;

[0032] FIG. 5B is a lateral view of the lumbar vertebra of FIG. 5A, with the stylet removed from the spinal needle;

[0033] FIG. 5C is a lateral view of the lumbar vertebra of FIG. 5B, with a cavity-forming device constructed in accordance with one embodiment of the present invention inserted into the vertebral body;

[0034] FIG. 5D is a lateral view of the lumbar vertebra of FIG. 5C, with the cavity-forming device inflated;

[0035] FIG. 5E is a lateral view of the lumbar vertebra of FIG. 5D, with the cavity-forming device deflated;

[0036] FIG. 5F is a lateral view of the lumbar vertebra of FIG. 5E, with the cavity-forming device removed from the vertebral body;

[0037] FIG. 5G is a lateral view of the lumbar vertebra of FIG. 5F, with a bone filler injected into the vertebral body;

[0038] FIG. 5H is a lateral view of the lumbar vertebra of FIG. 5G, with the spinal needle advanced into the cavity;

[0039] FIG. 5I is a lateral view of the lumbar vertebra of FIG. 5H, with a second bone filler injected into the vertebral body;

[0040] FIG. 5J is a lateral view of the lumbar vertebra of FIG. 5I, with additional bone filler injected into the vertebral body;

[0041] FIG. 5K is a lateral view of the lumbar vertebra of FIG. 5J, with additional bone filler injected into the vertebral body;

[0042] FIG. 5L is a lateral view of the lumbar vertebra of FIG. 5K, with the spinal needle removed from vertebral body;

[0043] FIG. 6A is a side view of a cavity-forming device constructed in accordance with an alternate embodiment of the present invention;

[0044] FIG. 6B is a close-up view of the distal end of the cavity-forming device of FIG. 6A;

[0045] FIG. 7A is a lateral view of a lumbar vertebra, depicting the cavity-forming device of FIG. 6A being inserted into the vertebra;

[0046] FIG. 7B is a lateral view of the lumbar vertebra of FIG. 7A, with the cavity-forming device deployed within the vertebra;

[0047] FIG. 7C is a lateral view of the lumbar vertebra of FIG. 7B, with the cavity-forming device withdrawn from the vertebra;

[0048] FIG. 8A is a lateral view of a lumbar vertebra, depicting an alternate procedure for treating a vertebral body in accordance with the teachings of the present invention;

[0049] FIG. 8B is a lateral view of the lumbar vertebra of FIG. 8A, with a cavity-forming device inserted into the bone filler;

[0050] FIG. 8C is a lateral view of the lumbar vertebra of FIG. 8B, with the cavity-forming device expanded in the cavity;

[0051] FIG. 9 is a side view of a cavity-forming device constructed in accordance with one embodiment of the present invention;

[0052] FIG. 10 is a close-up view of the distal end of a cavity-forming device of FIG. 9;

[0053] FIG. 11 is a close-up view of the distal end of a balloon catheter protruding from the distal end of a needle, depicting the inflation of the balloon material with an inflation medium;

[0054] FIG. 12 is a side view of a cavity-forming device constructed in accordance with an alternate embodiment of the present invention;

[0055] FIG. 13 is a side view of a cavity-forming device constructed in accordance with another alternate embodiment of the present invention;

[0056] FIG. 14 is a side view of a cavity-forming device constructed in accordance with another alternate embodiment of the present invention;

[0057] FIG. 15 is a side view of a cavity-forming device constructed in accordance with another alternate embodiment of the present invention;

[0058] FIG. 16A is a lateral view of a lumbar vertebra, depicting an alternate procedure for treating a vertebral body in accordance with the teachings of the present invention;

[0059] FIG. 16B is a lateral view of the lumbar vertebra of FIG. 16A, with bone filler injected into the vertebra;

[0060] FIG. 16C is a lateral view of the lumbar vertebra of FIG. 16B, with a cavity-forming device inserted into the vertebra;

[0061] FIG. 16D is a lateral view of the lumbar vertebra of FIG. 16C, with the cavity-forming device expanded in the cavity;

[0062] FIG. 17 is a side view of a cavity-forming device constructed in accordance with another alternate embodiment of the present invention;

[0063] FIG. 18 is a side view of a cavity-forming device constructed in accordance with another alternate embodiment of the present invention;

[0064] FIG. 19 is a cross-sectional view of the cavity-forming device of FIG. 18, taken along line 19-19; and

[0065] FIG. 20 is a cross-sectional view of the cavity-forming device of FIG. 18, taken along line 20-20.

DESCRIPTION OF THE INVENTION

[0066] As embodied and broadly described herein, the present invention is directed to surgical methods for repairing, reinforcing and/or treating weakened, diseased and/or fractured bone. The present invention is further directed to various devices for facilitating such surgical methods.

[0067] FIG. 1 depicts a typical human spine 1, in which a compression fracture 10 has occurred in a lumbar vertebra 100. As best shown in FIG. 3, vertebra 100 has fractured, with the top and bottom plates 103 and 104 depressing generally towards the anterior wall 10 of the vertebra 100 and away from their pre-fracture, normally parallel orientation (indicated generally as parallel lines 90).

[0068] FIG. 4 depicts a coronal (top) view of the vertebra of FIG. 3. Vertebra 100 includes a vertebral body 105, which extends on the anterior (i.e. front or chest) side of the vertebra 100. Vertebral body 105 is approximately the shape of an oval disk, with an anterior wall 10 and a posterior wall 261. The geometry of the vertebral body 105 is generally symmetric. Vertebral body 105 includes an exterior formed from compact cortical bone 110. The cortical bone 110 encloses an interior volume of reticulated cancellous, or spongy, bone 115 (also called medullar bone or trabecular bone).

[0069] The spinal canal 150 is located on the posterior (i.e. back) side of each vertebra 100. The spinal cord 151 passes through the spinal canal 150. A vertebral arch 135 surrounds the spinal canal 150. Left and right pedicles 120 of the vertebral arch 135 adjoin the vertebral body 105. The spinous process 130 extends from the posterior of the vertebral arch 135, as do the left and right transverse processes 125 and the mamillary processes 126.

[0070] FIG. 2 depicts a patient 50 prepared for disclosed methods of the present invention. These procedures can be performed on an outpatient or inpatient basis by a medical professional properly trained and qualified to perform the disclosed procedures. Desirably, the patient will be placed under general or local anesthetic for the duration of the surgical procedures.

[0071] In one embodiment of the present invention, a surgical method comprises inserting an insertion device 350 (see FIG. 5A) percutaneously into the bone, such as a fractured vertebral body 105 through, preferably, a targeted area of the back, depicted as 60 in FIG. 2. The insertion device 350 may be any type and size of hollow instrument, preferably having a sharp end. In one preferred embodiment, the insertion device 350 comprises a hollow needle of approximately eleven gauge diameter. An eleven gauge needle is preferred for the procedure because it incorporates

a hollow lumen of sufficient size to permit the passage of various instruments and materials, yet the overall size of the needle is small enough to minimize bone and tissue damage in the patient. It should be understood, however, that various other size needle assemblies, including needles of six to 14 gage, could be used with the devices and methods of the present invention, with varying results. In addition, various other access instruments, such as those described in U.S. Pat. Nos. 4,969,888, 5,108,404, 5,827,289, 5,972,015, 6,048,346 and 6,066,154, each of which are incorporated herein by reference, could be used in accordance with the teachings of the present invention, with varying results.

[0072] The insertion device 350 is preferably comprised of a strong, non-reactive, and medical grade material such as surgical steel. If desired, the insertion device 350 is attached to a manipulating assembly which is comprised of a non-reactive and medical grade material including, but not limited to, acrylonitrile-butadiene-styrene (ABS), polyethylene, polypropylene, polyurethane, Teflon, or surgical steel. FIG. 5A depicts a commercially available needle assembly typically used with various embodiments of the present invention, which are further described below.

[0073] As shown in FIG. 5A, an insertion device 350, such as an eleven gauge biopsy needle (commercially available from Becton Dickinson & Co of Franklin Lakes, N.J.) can be inserted through soft tissues of the back and into the vertebral body 105. Generally, the approach for such a procedure will be transpedicular, although various other approaches, including lateral, extrapedicular and/or anterior approaches, could be used, depending upon the level treated and/or intervening anatomical features well known to those of ordinary skill in the art. In one embodiment, the device 350 comprises a needle body 348 and a stylet 349, as is well known in the art. During insertion of the device 350, the location of the device 350 is desirably monitored using visualization equipment such as real-time X-Ray, CT scanning equipment 70 (see FIG. 2), MRI, or any other monitoring equipment commonly used by those of skill in the art, including computer aided guidance and mapping equipment such as the systems commercially available from BrainLab Corporation or General Electric Corporation.

[0074] In one preferred embodiment, the distal end 351 of the insertion device 350 is positioned in the vertebral body 105, preferably at a location towards the posterior side of the vertebral body 105. If desired, the distal end 351 could be positioned in various locations throughout the vertebral body 105, including towards the anterior side. Once in position, the stylet 349 of the insertion device 350 may be removed, see FIG. 5B, and a cavity-forming device 200 may be inserted through the shaft 348 and into the vertebral body 105. See FIG. 5C. The cavity-forming device 200, which is desirably comprised of a biologically compatible and medically acceptable material, can be a small mechanical tamp, reamer, hole punch, balloon catheter (as described below) or any appropriate device which is capable of displacing cancellous bone. Once the cavity-forming device is positioned within the vertebral body 105, it is used to displace cancellous bone 115, thereby creating a cavity 170. See FIG. 5F.

[0075] In one embodiment, shown in FIGS. 9 and 10, the cavity-forming device comprises a balloon catheter 200. The balloon catheter 200 desirably extends across at least 20% of the vertebral body, but could extend greater or lesser

amounts, depending upon the desired size of the cavity to be produced. In this embodiment, as the balloon catheter **201** is expanded, cancellous bone is displaced generally outward from the cavity **170** in a controlled manner, desirably forming a compressed-bone region **172** around a substantial portion of the outer periphery of the cavity **170**.

[0076] The balloon catheter **200**, which will be described in more detail below, is sized or folded to fit through the hollow interior of the shaft **348** and into a vertebral body **105**. Once in a desired position within the vertebral body **105**, the balloon catheter **190** is filled with a pressurized filling medium **275** appropriate for use in medical applications including, but not limited to, air, nitrogen, saline or water. See FIGS. **5D** and **11**. In a preferred embodiment, the filling medium **275** is a radiopaque fluid (such as Conray® fluid available commercially from Mallinkrodt, Inc., of St. Louis, Mo.), which allows the physician to visualize the catheter **190** during inflation. If desired, alternate ways of expanding the catheter, including mechanical expanders, jacks, expanding springs and/or expanding/foaming agents, could be used, with varying results.

[0077] In one embodiment, the catheter **201** is expanded to any appropriate volume which creates a cavity **170** within the vertebral body **105**. In a preferred embodiment, the catheter **201** is expanded to at least 0.20 cc in volume, but could be expanded to significantly greater sizes, such as 1, 2, 4, 6 or 8 cc, depending upon bone quality and density. After cavity creation, the catheter **201** is deflated (see FIG. **5E**) and removed from the vertebral body **105** and shaft **348** (see FIG. **5F**). Bone filler **180** is introduced through the shaft **348** and into the vertebral body **105** using any type of plunger, extruder and/or feed line assembly **349** compatible with the needle body **348**. Once injection of bone filler is complete, the shaft **348** can be withdrawn.

[0078] If desired, a portion of the balloon catheter **201** could be temporarily or permanently left within a vertebral body **105**. For example, after cavity formation and removal of the inflation medium, the deflated expanded section of the balloon catheter **201** could be refilled with bone filler **180** and left within the vertebral body **105**. Alternatively, the inflation medium **275** could comprise bone filler **180**. After the balloon catheter **201** is filled with such an inflation medium, at least a portion of the catheter **201** could be left permanently within the cavity **170**. In an alternate embodiment, the catheter **201** which is intended to remain with the cavity **170** could comprise a bio-absorbable material and/or fabric/mesh material as the expandable structure.

[0079] In creating the cavity **170**, the inflation of the catheter **201** causes the expandable material **210** to press against the cancellous bone **115** which may form a compressed bone region or "shell" **172** along much of the periphery of the cavity **170**. This shell **172** will desirably inhibit or prevent bone filler **180** from exiting the cavity **170**, thereby inhibiting extravazation of the bone filler and/or facilitating pressurization of the bone filler **180**, if desired, within the cavity. As the pressure in the cavity **170** increases, the walls of the cavity **170** will desirably be forced further outward by the bone filler **180**, compressing additional cancellous bone within the vertebral body **105** and/or increasing the size of the cavity **170**. If sufficient pressure is available, and integrity of the shell **172** can be maintained without significant leakage of bone filler **180**, pressures capable of moving fractured cortical bone can be developed.

[0080] In one embodiment of the present invention, after cavity formation, an amount of a material, such as a bone filler **180**, is introduced through the shaft **348** into the vertebral body **105** under low pressure. The amount of bone filler will desirably be more than the volume of the cavity **170**, however, less bone filler may be introduced with varying results. Once the cavity **170** is substantially filled, the continued introduction of bone filler **180** will desirably pressurize the bone filler **180** in the cavity **170** such that the increased pressure will cause at least a portion of the walls of the cavity to move outward, thereby enlarging the cavity **170** and further compressing cancellous bone and/or moving cortical bone. Desirably, introduction of the bone filler **180** will continue until bone filler leak from the vertebral body appears imminent, the cortical bone has regained its pre-fractured position and/or the practitioner determines that sufficient bone filler **180** has been injected into the bone. If desired, the physician can utilize the cavity-forming device to create additional cavities for bone filler, or the shaft **348** can be removed from the vertebral body to completed the procedure.

[0081] The bone filler **180** could be any appropriate filling material used in orthopedic surgery, including, but not limited to, allograft or autograft tissue, hydroxyapatite, epoxy, PMMA bone cement, or synthetic bone substitutes such as Osteoset® from Wright Medical Technology, medical grade plaster of paris, Skeletal Repair System (SRS®) cement from Norian Corporation, or Collagraft from Zimmer. As bone filler **180** is introduced into the vertebral body **105**, the introduction is desirably monitored by x-ray fluoroscopy, or any other appropriate monitoring device or method, to ensure that bone filler **180** does not flow outside of the vertebral body **105**. To facilitate visualization, the bone filler **180** may be mixed with a fluoroscopic agent, such as radio opaque barium sulfate. In another embodiment, the bone filler **180** could comprise a mixture of bone cement and a thixotropic material which desirably limits and/or prevents extravazation of the bone cement.

[0082] In an alternate embodiment of the disclosed method, shown in FIGS. **5G** through **5L**, a first bone filler **180** is introduced into the cavity **170**, the amount of first bone filler **180** being desirably less than or approximately equal to the volume of the cavity **170**. For example, if the balloon catheter **200** utilized to create the cavity **170** was inflated with 1.0 cc of inflation fluid, then less than or approximately 1.0 cc of bone filler **180** will initially be injected into the cavity **170**. Of course, if desired, an amount of first bone filler **180** greater than the cavity volume could be injected into the cavity. The shaft **348** is then re-positioned within the vertebral body **105**, see FIG. **5H**, with the distal end **351** of the device **350** desirably located within the bolus **400** of first bone filler **180** contained in the cavity **170**. As best shown in FIG. **5I**, a second amount of bone filler **182** is then injected into the vertebral body **105**, which desirably forces the first amount of bone filler **180** outward against the walls of the cavity **170**. Desirably, the first amount of bone filler **180** will resist extravazating out of the cavity **170** and will push outward against the walls of the cavity **170**, further compressing the cancellous bone **115** and/or increasing the size of the cavity **170**. Introduction of the second amount of bone filler **182** will desirably continue until bone filler leak from the vertebral body appears imminent, the cortical bone has regained its pre-fractured position, and/or the practitioner determines that sufficient bone filler **180** has been

injected into the bone. If desired, the physician could reinsert a catheter **200** to create an additional cavity, or the shaft **348** can be removed to complete the procedure.

[**0083**] FIGS. **8A** through **8C** depict an alternate embodiment of the disclosed method, in which the practitioner introduces a first material, such as a bone filler **180**, into the cavity **170**, and subsequently inserts a cavity-forming device **200** into the bone. The cavity-forming device **200** is then expanded, and desirably compresses the bone filler **180** against the walls of the cavity, sealing any significant cracks and/or venous passages through which the cement will flow. In one further embodiment, a practitioner may wait to allow the first bone filler to harden partially or fully prior to removing the cavity-forming device and/or prior to introducing a second material, such as a bone filler. The second material (not shown) can subsequently be injected into the vertebral body with little fear of leakage. If desired, this method could be utilized whenever cement leakage appears imminent, and can be repeated multiple times until the practitioner determines that sufficient bone filler **180** has been injected into the bone. In addition, the practitioner could repeat this procedure until the cortical bone has regained its pre-fractured position. In an alternate embodiment, the practitioner could utilize a cavity-forming device prior to the introduction of the first bone filler, and then introduce the first bone filler into the cavity, subsequently follow one or more of the described methods.

[**0084**] The first bone filler will desirably comprise a material that can be introduced into the cavity, but which will resist extravazation out of the cavity and/or vertebral body when the second bone filler is injected into the cavity. In one embodiment of the invention, the first and second bone fillers comprise bone cement, with the first bone cement being more resistant to extravazation than the second bone cement. For example, the ingredients of the first bone cement could be specifically tailored such that the first bone cement cures faster than the second bone cement. Alternatively, the first bone cement could be prepared and/or introduced into the vertebral body before the second bone cement, allowing the first bone cement to partially or fully cure before the second bone cement. Alternatively, the curing and/or hardening of the first bone cement could be accelerated (by applying heat, for example) or curing and/or hardening of the second bone cement could be retarded (by cooling, for example). In another embodiment, the first and second bone fillers comprise bone cement, with the first bone cement desirably being more viscous than the second bone cement. In another alternate embodiment, the first bone filler comprises an expandable structure, such as a stent.

[**0085**] In another embodiment, the first bone filler comprises a material more viscous than the second bone filler, the first and second bone fillers comprising different materials. In another embodiment, the first bone filler comprises a material which is more resistant to extravazation into the cancellous bone than the second bone filler. In another embodiment, the first bone filler comprises a material having particles generally larger than particles in the second bone filler. In a further embodiment, the particles of the first bone filler are generally larger than the average pore size within the cancellous bone. In another embodiment, the first bone filler comprises a settable material, such as a two-part polyurethane material or other curable bio-material.

[**0086**] FIGS. **16A** through **16D** depict an alternate embodiment of the disclosed method, in which a first material, such as a bone filler **180**, is initially introduced into the cancellous bone **115** of a human bone, such as a vertebral body **105**. An expandable structure **210**, such as that found at the distal end of a balloon catheter **200**, is subsequently inserted into the vertebral body **105**. The expandable structure **210** is then expanded, which displaces the bone filler **180** and/or cancellous bone **115**, creating a cavity **170** within the vertebral body **105**. In one embodiment, the expansion of the expandable structure **210** forces the bone filler **180** further into the cancellous bone **115**, and/or further compresses cancellous bone. To minimize bone filler **180** leakage, the bone filler may be allowed to partially or completely harden prior to expansion of the expandable structure **210**. Alternatively, the expandable structure **210** may be expanded, and the bone filler **180** allowed to partially or completely harden around the expandable structure **210**. In either case, a second material, optionally additional bone filler, may be introduced into the cavity **170**. In one embodiment, the second material is a material which supports the bone in a resting position. This method may be utilized whenever cement leakage appears imminent, and may be repeated multiple times until the practitioner determines that sufficient amounts and varieties of material have been introduced into the bone. Alternatively, the practitioner could halt introduction of filler material when the cortical bone regains or approximates its pre-fractured position.

[**0087**] By creating cavities and/or preferred flowpaths within the cancellous bone, the present invention obviates the need for extremely high pressure injection of bone filler into the cancellous bone. If desired, the bone filler could be injected into the bone at or near atmospheric and/or ambient pressures, or at pressures less than approximately 400 pounds per square inch, using bone filler delivery systems such as those described in co-pending U.S. patent application Ser. No. 09/134,323, which is incorporated herein by reference. Thus, more viscous bone fillers (such as, for example, thicker bone cement) can be injected into the bone under low pressures (such as, for example, exiting the delivery device at a delivery pressure at or near ambient or atmospheric pressure), reducing opportunities for cement leakage and/or extravazation outside of the bone.

Cavity-Forming Devices

[**0088**] The present invention also includes cavity-forming devices constructed in accordance with the teachings of the disclosed invention. In one embodiment, the cavity-forming device comprises a balloon catheter **201**, as shown in FIGS. **9**, **10**, and **11**. The catheter comprises a hollow tube **205**, which is desirably comprised of a medical grade material such as plastic or stainless steel. The distal end **206** of the hollow tube **205** is surrounded by an expandable material **210** comprised of a flexible material such as commonly used for balloon catheters including, but not limited to, metal, plastics, composite materials, polyethylene, mylar, rubber or polyurethane. One or more openings **250** are disposed in the tube **205** near the distal end **206**, desirably permitting fluid communication between the hollow interior of the tube **205** and the lumen formed between the tube **205** and the expandable structure **210**. A fitting **220**, having one or more inflation ports **222**, **224**, is secured to the proximal end **207** of the tube **205**. In this embodiment, once the catheter **201** is in its desired position within the vertebral body **105**, an

inflation medium 275 is introduced into the fitting 220 through the inflation port 222, where it travels through the fitting 220, through the hollow tube 205, through the opening(s) 250 and into the lumen 274 between the expandable structure 210 and the hollow tube 205. As injection of the inflation medium 275 continues, the pressure of the inflation medium 275 forces the expandable structure 210 away from the hollow tube 205, inflating it outward and thereby compressing cancellous bone 115 and forming a cavity 170. Once a desired cavity size is reached, the inflation medium 275 is withdrawn from the catheter 200, the expandable structure collapses within the cavity 170, and the catheter 200 may be withdrawn.

[0089] For example, a balloon catheter 201 constructed in accordance with one preferred embodiment of the present invention, suitable for use with an 11-gauge needle, would comprise a hollow stainless steel hypodermic tube 205, having an outer diameter of 0.035 inches and a length of 10.75 inches. One or more openings 250 are formed approximately 0.25 inches from the distal end of the tube 205. In a preferred embodiment, the distal end 206 of the hollow tube 205 is sealed closed using any means well known in the art, including adhesive (for example, UV 198-M adhesive commercially available from Dymax Corporation—cured for approximately 15 minutes under UV light).

[0090] In one embodiment, the hollow tube 205 is substantially surrounded by an expandable structure 210 comprising an extruded tube of polyurethane (for example, TEXIN® 5290 polyurethane, available commercially from Bayer Corporation). In one embodiment, the polyurethane tube has an inner diameter of 0.046 inches, an outer diameter of 0.082 inches, and a length of 9½ inches. The distal end of the polyurethane tube is bonded to the distal end 206 of the hollow tube 205 by means known in the art, such as by a suitable adhesive (for example, UV 198-M adhesive). Alternatively, the polyurethane tube may be heat sealed about the distal end 206 of the hollow tube 205 by means well known in the art. A ¾ inch long piece of heat shrink tubing 215 (commercially available from Raychem Corporation), having a ⅜ inch outer diameter, may be secured around the proximal end of the polyurethane tubing. In one embodiment, the proximal end of the hollow tubing 205 is inserted into the fitting 220 and the heat shrink tubing 215 is desirably bonded into the fitting 220 using a suitable adhesive known in the art, such as UV 198-M. The fitting 220, which may be a Luer T-fitting, commercially available from numerous parts suppliers, may be made of any appropriate material known to those of skill in the art. The fitting 220 comprises one or more ports 222, 224 for attachment to additional instruments, such as pumps and syringes (not shown). If desired, the hollow tube 205 can similarly be bonded into the fitting 220 using a suitable adhesive. Alternatively, as shown in FIG. 12, the expandable structure 210 could be significantly shorter than the hollow tube 205 and be bonded at its distal end 206 and its proximal end 209 to the hollow tube 205.

[0091] The hollow tube 205 and one or more openings 250 facilitate the withdrawal of inflation medium from the catheter during the disclosed procedures. When a catheter is deflated, the expandable structure 210 will normally collapse against the tube 205, which can often seal closed the lumen (in the absence of at least one secondary withdrawal

path) and inhibit further withdrawal of inflation medium from the expanded structure 210 of a catheter. However, in an embodiment of the disclosed invention, the one or more openings 250 near the distal end of the tube 205 allow inflation medium 275 to be drawn through the hollow hypodermic tube 205, further deflating the expandable structure 210. The strong walls of the hollow hypodermic tube 205 resist collapsing under the vacuum which evacuates the inflation medium, maintaining a flowpath for the inflation medium and allowing the inflation medium to be quickly drawn out of the catheter, which desirably permits deflation of the catheter in only a few seconds.

[0092] In the disclosed embodiment, as the catheter 201 is inflated, the inflation medium 275 will typically seek to fill the entire lumen between the expandable structure 210 and the hollow tube 205, thus expanding the catheter 201 along the entire length of the expandable structure 210. However, because much of the catheter 201 is located within the lumen of the shaft 348, with the distal end 206 of the catheter 201 extending into the vertebral body 105, the shaft 348 will desirably constrain expansion of the expandable structure 210, causing the expandable structure 210 to expand primarily at the distal end 206 of the catheter 200. Desirably, further insertion or withdrawal of the catheter 201 will alter the amount of the expandable structure 210 extending from the distal end of the shaft 348, thereby increasing or decreasing the length of the expandable structure 210 that is free to expand within the vertebral body 105. By choosing the amount of catheter 201 to insert into the vertebral body 105, the practitioner can alter the length of the expandable structure, and ultimately the size of the cavity 170 created by the catheter 201, during the surgical procedure. Therefore, the disclosed embodiments can obviate and/or reduce the need for multiple catheters of varying lengths. If desired, markings 269 (see FIG. 9) can be placed along the proximal section of the catheter which correspond to the length of the catheter 201 extending from the shaft 348, allowing the practitioner to gauge the size of the expandable structure 210 of the catheter 200 within the vertebral body 105. Similarly, in an alternate embodiment as disclosed below, the cavity-forming device 201 could incorporate markings corresponding to the length of the bristles 425 extending beyond the tip of the shaft 348.

[0093] In an alternate embodiment, shown in FIG. 13, the length of an expandable section 211 of the catheter can be further constrained by securing and/or adhering the expandable structure 210 at a secondary location 214 along the hollow tube 205, thereby limiting expansion beyond the secondary location 214. For example, if a desired maximum length of the expandable section 211 were 3 inches, then the expandable structure 210 could be secured to the hollow tube 205 at a secondary location 214 approximately three inches from the distal end 206 of the hollow tube 205. This arrangement would desirably allow a practitioner to choose an expanded length of the expandable section 211 of up to three inches, while limiting and/or preventing expansion of the remaining section 203 of the catheter 201. This arrangement can also prevent unwanted expansion of the portion 202 of the catheter extending out of the proximal end 191 of the shaft body 348 (see FIG. 5C).

[0094] As previously noted, in the disclosed embodiment, the expandable structure is desirably secured to the distal end of the hollow tube, which will facilitate recovery of

fragments of the expandable structure **210** if the expandable structure **210** is torn or damaged, such as by a complete radial tear. Because the hollow tube **205** will desirably remain attached to the fragments (not shown) of the expandable structure **210**, these fragments can be withdrawn from the vertebral body **105** with the hollow tube **205**. In addition, the distal attachment will desirably prevent and/or reduce significant expansion of the expandable structure **210** along the longitudinal axis of the hollow tube **205**.

[0095] FIG. 17 depicts a cavity-forming device **300** constructed in accordance with an alternate embodiment of the present invention. Because many of the features of this embodiment are similar to embodiments previously described, like reference numerals will be used to denote like components. In this embodiment, the hollow tube **205** extends through the fitting **220**, such as a t-shaped fitting, and is secured to a cap **310**. In a preferred embodiment, the hollow tube **205** is capable of rotation relative to the fitting **220**. If desired, a seal (not shown), such as a silicone or teflon o-ring, can be incorporated into the proximal fitting **222** to limit and/or prevent leakage of inflation medium past the hollow tube **205**.

[0096] In use, a cavity-forming device **300** compresses cancellous bone and/or forms a cavity in a manner similar to the embodiments previously described. However, once the cavity is formed and withdrawal of the device **300** is desired, the cap **310** can be rotated, twisting the expandable material **210** relative to the fitting **220** and drawing the expandable structure **210** against the hollow tube **205**, desirably minimizing the overall outside diameter of the expandable portion of the device **300**. The device **300** can then easily be withdrawn through the shaft **348**. Even where the expandable structure **210** has plastically deformed, or has failed in some manner, the present embodiment allows the expandable structure **210** to be wrapped around the hollow tube **205** for ease of withdrawal and/or insertion. Alternatively, the hollow tube **205** may be capable of movement relative to the longitudinal axis of the fitting **220**, which would further stretch and/or contract the expandable structure **210** against the hollow tube **205**.

[0097] FIGS. 6A and 6B depict a cavity-forming device **410** constructed in accordance with an alternate embodiment of the present invention. Cavity-forming device **410** comprises a shaft **420** which is desirably sized to pass through the shaft **348** of an insertion device **350**. A handle assembly **415**, which facilitates manipulation of the cavity-forming device **410**, is secured to the proximal end **412** of the shaft **420**. One or more wires or "bristles" **425** are secured to the distal end **423** of the shaft **420**. The bristles **425** can be secured to the shaft **420** by welding, soldering, adhesives or other securing means well known in the art. Alternatively, the bristle(s) **425** can be formed integrally with the shaft **420**, or can be etched from a shaft using a laser or other means well known in the art. The bristles and shaft may be formed of a strong, non-reactive, and medical grade material such as surgical steel. In one embodiment, the bristles **425** extend along the longitudinal axis of the shaft **425**, but radiate slightly outward from the shaft axis. In this manner, the bristles **425** can be collected or "bunched" to pass through the shaft **348**, but can expand or "fan" upon exiting of the shaft **348**. If desired, the bristles can be straight or curved, to facilitate passage through the cancellous bone **115**. In addition, if desired, one or more of the bristles **425**

may be hollow, allowing a practitioner to take a biopsy sample of the cancellous bone during insertion of the device **410**.

[0098] As shown in FIG. 7, the cavity-forming device **410** can desirably be inserted through a shaft **348** positioned in a targeted bone, such as a vertebral body **105**. As the bristles **425** enter the cancellous bone **115**, the bristles **425** will desirably displace the bone **115** and create one or more cavities **426** or preferred flowpaths in the vertebral body. If desired, a practitioner can withdraw the bristles **425** back into the shaft **348**, reposition the cavity-forming device **410** (such as by rotating the device **410**), and reinsert the bristles **425**, thereby creating additional cavities in the cancellous bone **115**. After removal of the cavity-forming device **410**, a material, such as a bone filler (not shown), may be introduced through the shaft **348**. The bone filler will desirably initially travel through the cavities **426** created by the bristles **425**. If desired, a practitioner may interrupt introduction of the bone filler and create additional cavities by reinserting the cavity-forming device **410**. In addition, in the event bone filler leakage occurs or is imminent, a practitioner can interrupt bone filler injection, create additional cavity(ies) as described above, wait for the introduced/leaking bone filler to harden sufficiently to resist further extravazation, and then continue introduction of bone filler. As previously described, the bone filler could comprise many different materials, or combinations of materials, with varying results.

[0099] FIG. 14 depicts a cavity-forming device **500** constructed in accordance with an alternate embodiment of the present invention. The cavity-forming device **500** comprises a shaft **520** which is sized to pass through the shaft **348** of an insertion device **350**. A handle assembly **515**, which facilitates manipulation of the cavity-forming device **500**, is secured to the proximal end **512** of the shaft **520**. The shaft **520** of the cavity-forming device **500** is desirably longer than the shaft **348** of the insertion device **350**. The distal end **525** of the shaft **520** can be beveled (not shown) to facilitate passage through cancellous bone **115**, or can be rounded or flattened to minimize opportunities for penetrating the anterior wall **10** of the vertebral body **105**. In addition, if desired, the distal **525** end of the shaft **520** could be hollow (not shown), allowing the practitioner to take a biopsy sample of the cancellous bone **115** during insertion of the device **500**.

[0100] FIG. 15 depicts a cavity-forming device **600** constructed in accordance with an alternate embodiment of the present invention. Cavity-forming device **600** comprises a shaft **620** which is sized to pass through the shaft **348** of an insertion device **350**. A handle assembly **615**, which facilitates manipulation of the cavity-forming device **600**, is secured to the proximal end **612** of the shaft **620**. The shaft **620** is desirably longer than the shaft **348** of insertion device **350**. The distal end **625** of the shaft **620** can be beveled (not shown) to facilitate passage through cancellous bone **115**, or can be rounded or flattened to minimize opportunities for penetrating the anterior wall **10** of the vertebral body **105**. In this embodiment, the distal end **625** of the device **600** incorporates drill threads **627** which can facilitate advancement of the device **600** through cancellous bone **115**. In addition, if desired, the distal **625** end of the shaft **620** could be hollow, allowing the practitioner to take a biopsy sample of the cancellous bone **115** during insertion of the device **600**.

[0101] After removal of the device(s), bone filler (not shown) may be introduced through the shaft 348. Desirably, the bone filler will initially travel through the cavity(ies) created by the device(s). If desired, a practitioner can interrupt introduction of bone filler and create additional cavity(ies) by reinserting the device(s). In addition, in the event bone filler leakage occurs or is imminent, the practitioner can interrupt bone filler introduction, create additional cavity(ies) as described above, wait for the introduced/leaking bone filler to harden sufficiently, and then continue introducing bone filler. As previously described, the bone filler could comprise many different materials, or combinations of materials, with varying results.

[0102] FIGS. 18-20 depicts a cavity-forming device 600a constructed in accordance with another alternate embodiment of the present invention. Because many of the components of this device are similar to those previously described, similar reference numerals will be used to denote similar components. Cavity-forming device 600a comprises a shaft 620a which is sized to pass through the shaft 348 of an insertion device 350. A handle assembly 615a, which facilitates manipulation of the cavity-forming device 600a, is secured to the proximal end 612a of the shaft 620a. The shaft 620a is desirably longer than the shaft 348 of insertion device 350. The distal end 625a of the shaft 620a can be rounded or beveled to facilitate passage through cancellous bone 115, or can be or flattened to minimize opportunities for penetrating the anterior wall 10 of the vertebral body 105.

[0103] An opening or window 700 is desirably formed in the shaft 620a. As shown in FIGS. 19 and 20, an expandable structure 710 is located at least partially within the shaft 620a, desirably at a position adjacent the window 700. Upon introduction of inflation fluid through a lumen extending through the shaft 620a, the expandable structure 710 expands and at least a portion of the expandable structure 710 will extend out of the shaft 620a through the window 700. Desirably, as the structure continues to expand, the expandable structure 710 will "grow" (P1 to P2 to P3 in FIG. 20) through the window 700, thereby compacting cancellous bone, creating a cavity and/or displacing cortical bone. Upon contraction of the expandable structure 710, most of the expandable structure 710 will desirably be drawn back into the shaft 620a for removal of the tool from the vertebral body. In one embodiment, at least a portion of the material comprising the expandable structure 710 will plastically deform as it expands.

[0104] The expandable structure 710 may be comprised of a flexible material common in medical device applications, including, but not limited to, plastics, polyethylene, mylar, rubber, nylon, polyurethane, metals or composite materials. Desirably, the shaft 620a will comprise a material that is more resistant to expansion than the material of the expandable structure 710, including, but not limited to, stainless steel, ceramics, composite material and/or rigid plastics. In an alternate embodiment, similar materials for the expandable structure 710 and shaft 620a may be used, but in different thickness and/or amounts, thereby inducing the expandable structure to be more prone to expansion than the shaft 620a material. The expandable structure 710 may be bonded directly to the shaft 620a by various means well known in the art, including, but not limited to, means such as welding, melting, gluing or the like. In alternative

embodiments, the expandable structure may be secured inside or outside of the shaft 620a, or a combination thereof.

[0105] As previously noted, any of the cavity-forming devices 500, 600 and 600a may be inserted through a shaft 348 positioned in a targeted bone, such as a vertebral body 105. As the device(s) enter the cancellous bone 115, they will desirably displace the bone 115 and create one or more cavities in the vertebral body. If desired, the physician can withdraw the device(s) back into the shaft 348 and reinsert as necessary to create the desired cavity(ies) in the cancellous bone 115.

[0106] In the embodiment of a cavity-forming device of FIGS. 18-20, the cavity-forming device 600a may be utilized without an associated insertion device. In such a case, the cavity-forming device desirably will incorporate a sharpened distal tip capable of penetrating the soft tissues and cortical/cancellous bone of the vertebral body. If desired, the distal tip can be hollow or a solid construct. Similarly, the window may extend around more or less of the periphery of the shaft 620a, depending upon the size and configuration of the expandable structure and the desired strength of the cavity-forming device.

[0107] By creating one or more cavities within the cancellous bone 115, the cavity-forming devices of the present invention desirably create preferred flowpaths for the bone filler 180. In addition, the cavity-forming devices can also desirably close and/or block other natural flowpaths out of the cavity, such as veins and/or cracks in the cancellous bone. Moreover, methods and devices disclosed herein can be used to manipulate bone filler already introduced into the bone. Thus, the present invention reduces opportunities for cement leakage outside of the vertebral body and/or improves the distribution of bone filler throughout significant portions of the vertebral body. In addition, the creation of cavities and desired flowpaths described in the present invention permits the placement of biomaterial more safely, under greater control and under lower pressures.

[0108] In addition to the specific uses described above, the cavity-forming devices and methods described herein would also be well-suited for use in treating and/or reinforcing weakened, diseased and/or fractured bones and other organs in various locations throughout the body. For example, the disclosed devices and methods could be used to deliver reinforcing materials and/or medications, such as cancer drugs, replacement bone cells, collagen, bone matrix, demineralized calcium, and other materials/medications, directly to a fractured, weakened and/or diseased bone, thereby increasing the efficacy of the materials, reinforcing the weakened bone and/or speed healing. Moreover, injection of such materials into one bone within a body could permit the medication/material to migrate and/or be transported to other bones and/or organs in the body, thereby improving the quality of bones and/or other organs not directly injected with the materials and/or medications.

[0109] Other embodiments and uses of the invention will be apparent to those skilled in the art from consideration of the specification and practice of the invention disclosed herein. All documents referenced herein are specifically and entirely incorporated by reference. The specification and examples should be considered exemplary only with the true scope and spirit of the invention indicated by the following claims. As will be easily understood by those of ordinary

skill in the art, variations and modifications of each of the disclosed embodiments can be easily made within the scope of the claims.

We claim:

1. A system comprising

an elongated shaft sized and configured to establish an access path to bone having an interior volume occupied, at least in part, by cancellous bone, the elongated shaft including a distal end portion having a side opening, and

a first tool sized and configured to be carried by the shaft and including a region that is capable of being controllably advanced by a user through the side opening to project outside the distal end portion and contact cancellous bone.

2. A system according to claim 1

wherein contact between the region and cancellous bone modifies cancellous bone for introduction of bone filling material.

3. A system according to claim 1

wherein contact between the region and cancellous bone creates at least one flow path for bone filling material.

4. A system according to claim 1

wherein the region is capable of expansion into contact with cancellous bone.

5. A system according to claim 1

wherein the region is capable of inflation into contact with cancellous bone.

6. A system according to claim 1

wherein contact with cancellous bone creates a cavity in the cancellous bone.

7. A system according to claim 1

wherein the region is sized and configured to move fractured cortical bone.

8. A system according to claim 1

further including a second tool to convey a volume of bone filling material into cancellous bone contacted by the region.

9. A system according to claim 8

wherein the bone filling material comprises bone cement.

10. A system according to claim 1

wherein the region projecting outside the distal end portion includes a curved surface.

11. A system according to claim 1

wherein the region forms into a curved surface during advancement through the side opening.

12. A system according to claim 1

wherein the elongated shaft and the first tool are sized and configured to be mutually manipulated as a unit within cancellous bone.

13. A system according to claim 1

wherein the region is capable of being controllably withdrawn by a user through the side opening back into the shaft.

14. A system according to claim 1

wherein the first tool secured within the shaft.

15. A system according to claim 1

wherein the shaft comprises a cannula.

16. A system according to claim 1

wherein the shaft comprises a rigid material.

17. A system according to claim 1

wherein the shaft comprises a metal material.

18. A system according to claim 1

wherein the shaft comprises a plastic material.

19. A system according to claim 1

wherein the region comprises a material that is more prone to flexure than the shaft.

20. A system according to claim 1

wherein the region comprises a plastic material.

21. A system according to claim 1

wherein the region comprises a metal material.

22. A system according to claim 1

wherein the shaft includes a proximal end comprising a handle assembly.

23. A method comprising

establishing an access path to bone having an interior volume occupied, at least in part, by cancellous bone by placing within the cancellous bone an elongated shaft including a distal end portion having a side opening, and

modifying cancellous bone for introduction of bone filling material by advancing a tool through the side opening to project outside the distal end portion to contact cancellous bone.

24. A method according to claim 23

further including conveying bone filling material into cancellous bone contacted by the tool.

25. A method according to claim 23

wherein the tool projecting outside the distal end portion includes a curved surface.

26. A method according to claim 23

further including withdrawing the tool through the side opening back into the shaft.

27. A method according to claim 23

further including conveying bone filling material into cancellous bone through the shaft.

28. A method according to claim 23

wherein the bone comprises a vertebral body.

29. A method comprising

establishing an access path to bone having an interior volume occupied, at least in part, by cancellous bone by placing within the cancellous bone an elongated shaft including a distal end portion having a side opening, and

creating at least one flow path for a bone filling material in the cancellous bone by advancing a tool through the side opening to project outside the distal end portion to contact cancellous bone.

30. A method according to claim 29

further including conveying bone filling material into cancellous bone contacted by the tool.

31. A method according to claim 29

wherein the tool projecting outside the distal end portion includes a curved surface.

32. A method according to claim 29

further including withdrawing the tool through the side opening back into the shaft.

33. A method according to claim 29

further including conveying bone filling material into cancellous bone through the shaft.

34. A method according to claim 29

wherein the bone comprises a vertebral body.

* * * * *