

(19) World Intellectual Property  
Organization  
International Bureau



(43) International Publication Date  
10 March 2005 (10.03.2005)

PCT

(10) International Publication Number  
**WO 2005/021222 A1**

(51) International Patent Classification<sup>7</sup>: **B26B 1/08**, 5/00

(21) International Application Number:  
PCT/US2004/027429

(22) International Filing Date: 23 August 2004 (23.08.2004)

(25) Filing Language: English

(26) Publication Language: English

(30) Priority Data:  
10/649,915 26 August 2003 (26.08.2003) US

(71) Applicants and  
(72) Inventors: **SUMMERS, Guy** [US/US]; 1295 Friendship Lane West, Colorado Springs, CO 80904 (US). **SUMMERS, Rennie** [US/US]; 1295 Friendship Lane West, Colorado Springs, CO 80904 (US).

(74) Agents: **KINNER, Brian** et al.; Suite 3200, 555 17th Street, Denver, CO 80241 (US).

(81) Designated States (unless otherwise indicated, for every kind of national protection available): AE, AG, AL, AM,

AT, AU, AZ, BA, BB, BG, BR, BW, BY, BZ, CA, CH, CN, CO, CR, CU, CZ, DE, DK, DM, DZ, EC, EE, EG, ES, FI, GB, GD, GE, GH, GM, HR, HU, ID, IL, IN, IS, JP, KE, KG, KP, KR, KZ, LC, LK, LR, LS, LT, LU, LV, MA, MD, MG, MK, MN, MW, MX, MZ, NA, NI, NO, NZ, OM, PG, PH, PL, PT, RO, RU, SC, SD, SE, SG, SK, SL, SY, TJ, TM, TN, TR, TT, TZ, UA, UG, US, UZ, VC, VN, YU, ZA, ZM, ZW.

(84) Designated States (unless otherwise indicated, for every kind of regional protection available): ARIPO (BW, GH, GM, KE, LS, MW, MZ, NA, SD, SL, SZ, TZ, UG, ZM, ZW), Eurasian (AM, AZ, BY, KG, KZ, MD, RU, TJ, TM), European (AT, BE, BG, CH, CY, CZ, DE, DK, EE, ES, FI, FR, GB, GR, HU, IE, IT, LU, MC, NL, PL, PT, RO, SE, SI, SK, TR), OAPI (BF, BJ, CF, CG, CI, CM, GA, GN, GQ, GW, ML, MR, NE, SN, TD, TG).

**Published:**  
— with international search report  
— before the expiration of the time limit for amending the claims and to be republished in the event of receipt of amendments

For two-letter codes and other abbreviations, refer to the "Guidance Notes on Codes and Abbreviations" appearing at the beginning of each regular issue of the PCT Gazette.

(54) Title: DUAL BLADE UTILITY KNIFE

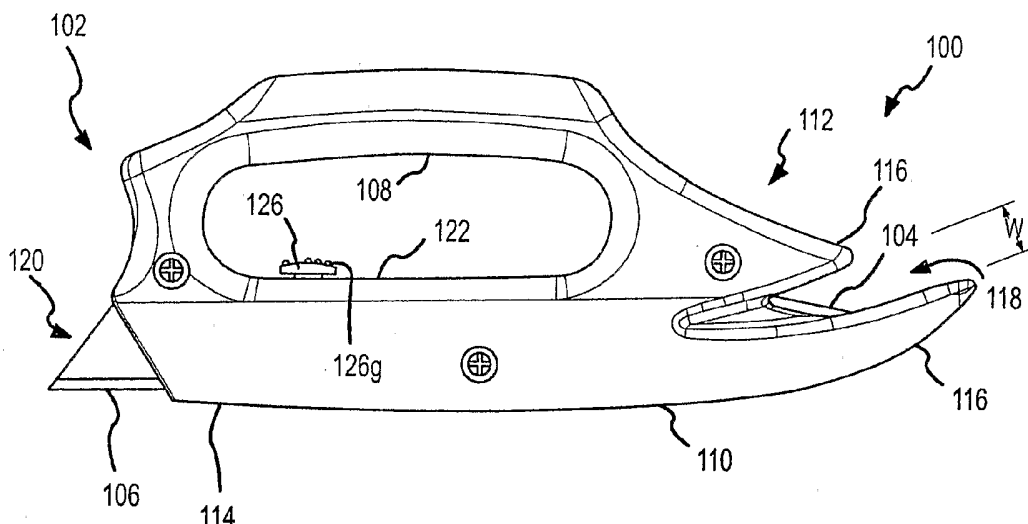

(57) Abstract: The present invention provides a dual blade utility knife useful in various fields. In particular, the dual blade utility knife contains a fixed cutting element contained in a gap that inhibits injury or accidents, a.k.a. a safety knife. The second cutting element is designed to be retractable. The retractable blade can be retracted during use of the safety blade, inhibiting injury or accidents, but extended to make cuts, such as an initial cut in a material.

WO 2005/021222 A1

## DUAL BLADE UTILITY KNIFE

### FIELD OF THE INVENTION

The present invention relates to utility knives and, more particularly, a dual blade utility knife having a fixed cutting element in a safety holder and a retractable cutting element.

### BACKGROUND OF THE INVENTION

Knives are useful tools for various activities including hunting, camping, roofing, carpentry, as well as other industrial and domestic activities. Frequently, these knives comprise a cutting element that is retractable or foldable into a position that is safe for handling. When extended or unfolded, however, these knives are relatively unsafe to handle because it is relatively easy to cut oneself or others accidentally.

In order to prevent accidental cuts, some knives come in safety holders. These safety holders frequently are designed with a holder having a neck or gap in which the cutting element resides. Frequently, the cutting edge in safety holders is not retractable, but sometimes the cutting edge is retractable. While these knives are safer than regular knives, retractable knives, and foldable knives, they are not very useful. In particular, making the initial cut into a fabric, tarp, hide, or the like is difficult because the cutting edge residing in the safety holder cannot engage the fabric, tarp, hide, or the like until the same can be treaded into the neck. For example, in hunting applications, it would be difficult to use safety knives to remove the hide of an animal without using a separate tool to make an initial piece or the like.

To avoid this, some blades make the safety feature a retractable feature and/or the safety blade moveable. However, this reduces the stability of the blade or safety feature making the solution less than desirable. Also, the safety feature can be forgotten or broken, reducing its effectiveness. Thus, it would be desirous to develop a fixed cutting edge contained in a safety holder that also

had a separate retractable tool for making initial cuts in a material such that the material can be tread into the safety holder and cut by the fixed cutting edge.

## SUMMARY OF THE INVENTION

To attain the advantages and purposes of the present invention, a utility  
5 knife is provided. The utility knife includes a handle, a first cutting edge, and a  
second cutting edge. The handle comprises a grip and a body. The body having  
a first end with a plurality of extension forming a gap and a second end with a  
slot. The first cutting edge is fixedly coupled to the body such that the first  
cutting resides in the gap between the plurality of extensions. The second  
10 cutting edge is slidably coupled to the slot such that it has at least one extended  
position and at least one retracted position.

The foregoing and other features, utilities and advantages of the invention  
will be apparent from the following more particular description of a preferred  
embodiment of the invention as illustrated in the accompanying drawings.

## 15 BRIEF DESCRIPTION OF THE DRAWING

The accompanying drawings, which are incorporated in and constitute a  
part of this specification, illustrate embodiments of the present invention, and  
together with the description, serve to explain the principles thereof. Like items  
in the drawings are referred to using the same numerical reference.

20 FIG. 1 is an elevation view of a utility knife consistent with one  
embodiment of the present invention; and

FIG. 2 is an exploded perspective view of the utility knife of FIG. 1.

## DETAILED DESCRIPTION

25 The present invention will be described with regard to FIGS. 1 and 2. The  
below description relates to using the dual bladed utility knife, one of ordinary  
skill in the art on reading the disclosure will recognize that the present invention

could be useful in a number of fields, such as, for example, hunting, carpentry, roofing, inventory stocking, fisheries, and the like. Any specific examples of uses mentioned for the present invention should be considered exemplary and non-limiting.

5 Referring first to FIG. 1, an elevation view of a utility knife 100 is shown. Utility knife 100 comprises a handle 102, a first cutting element 104, and a second cutting element 106. Handle 102 comprises a grip portion 108 and a body portion 110. As shown, grip portion 108 and body portion 110 comprise a single molded unit, but could be separate parts coupled together as desired.  
10 Actually, as shown to and to facilitate manufacturing,  $\frac{1}{2}$  of grip portion and  $\frac{1}{2}$  of body portion 110 are a single unit that is mated to the other half (shown in FIG. 2). Body portion 110 has a first end 112 and a second end 114. First cutting element 104 resides on the first end 112 and second cutting element 106 resides on the second end. Also, grip portion 108 is shown as having a generally "C" shape, but that is also exemplary and other style handles are possible, such as,  
15 for example, conventional finger grips, a T shaped handle, a L shaped handle, or the like.

First end 112 comprises a pair of forward extensions 116 or prongs that form a gap 118. Gap 118 has a width W that should be sized and/or shaped to  
20 inhibit fingers from intentionally or accidentally contacting first cutting element 104.

Second end 114 comprises a cutting element slot 120 and a latch track 122 (best seen in FIG. 2). Latch track 122 contains a plurality of notches 124 (not shown in FIG. 1, but shown in FIG. 2). Slot 120 is designed with sufficient  
25 height and width to receive a cutting element, such as a razorblade, awl, pick, saw, serrated blade, or the like. An elongated opening would be used for a razorblade while a circular opening may be used for an awl, etc. While latch track 122, nub 126, and notches 124 are described with relation to second end 114, notches 122 could be anywhere on knife 100. Nub 126 is attached to second  
30 cutting element 106, as described below, such that moving nub 126 along latch

track 122 moves second cutting element 106 between extended position(s) and retracted position(s). Further, nub 126 is designed as a thumb rest or the like it can be any number of convenient shapes and sizes. Nub 126 may be designed with one or more grooves 126g to inhibit slippage.

5 First cutting element 104 is fixedly attached to body portion 110 such that first cutting element 104 resides in safety gap 118. The term fixedly attached is used to mean first cutting element 104 is not slidably attached to body portion 110. First cutting element 104 could be removed and replaced with a new cutting element as desired. First cutting element 104 is shown as a slicing or  
10 sawing type of cutting element, such as a serrated blade or a razorblade, but first cutting element 104 could be a piecing element as well, such as, for example, an awl, a pick, or the like.

Second cutting element 106 is slidably coupled to second end 114. While shown as a blade for slizing, second cutting element 106 could be a tool more  
15 adapt for other functions, such as piercing or sawing. Other tools include an awl, pick, saw, wedge, or the like. Making first cutting element 104 and second cutting element 106 the same type of cutting element, however, makes it relatively easy to replace worn or damaged cutting elements. Further, it is envisioned that first cutting element 104 and second cutting element 106 would  
20 be standard utility knife blades, such as the type of blades that are readily available at pharmacy stores, convenient stores, and grocery stores.

Referring now to FIG. 2, an exploded view of utility knife 100 is shown. As can be seen, handle 102 actually comprises left handle 102L and right handle 102R connected by elements 202 residing in holes 204. Elements 202 and holes  
25 204 could be, for example, screws and screw holes, nuts and bolts, snap lock fittings, or the like. Handle 102L and handle 102R fit together and form internal space 206. Handle 102 does not need to be made in halves, but it is believed making handle 102 in halves facilitates manufacturing, storage, and cutting element replacement.

Internal space 206 contains a first cutting element holding notch 208, a spare cutting element holding notch 210, a second cutting element slide 212, and a second cutting element slider 214. Spare cutting element holding notch 210 is optional, but if present can hold a number of spare cutting elements 216. Also,  
5 second cutting element slider 214 could be integrated into second cutting element 106 to comprise a single piece. If first cutting element 104 and second cutting element 106 are different types of elements, such as, for example, a razorblade and an awl, a second spare cutting element holding notch could be incorporated into internal space 206.

10 First cutting element holding notch 208 holds first cutting element 104 in place by a frictional engagement between handle 102L and handle 102R. The frictional engagement between handle 102L and 102R is provided by members 202 being tightened or inserted into holes 204 until a sufficient frictional engagement is obtained. Optionally, first cutting element holding notch 208  
15 could have an engaging channel 218, such as a V shaped channel, to facilitate holding first cutting element 104 in place. While other engagements are possible, it is believed the frictional holding force from handle 102 will provide sufficient stability to cutting element 104.

Second cutting element slider 214 comprises a cutting element holder 220,  
20 an arm 222, a latch 224, and a connector 226 that is connected to nub 126. Connector 226 extends through and is slidably received in latch track 122 such that nub 126 is accessible above latch track 122 (see FIG. 1). Latch 224 comprises one or more prongs 228 on arm 222. Prongs 228 are sized to engage in notches 124 to hold second cutting element 106 in position. Arm 222 is  
25 elastically deformable, such that when nub 126 is not depressed, the elastic force from arm 222 holds prongs 228 in notches 124 that in turn holds second cutting element 106 in place, whether in one or more extended positions and/or in one or more retracted position. When nub 126 is depressed it elastically deforms arm 222 such that prongs 228 are released from notches 124. When released, slider  
30 214 is movable in slide 212, such that second cutting element 106 can slide, such

as from an extended position (shown in FIG. 1) to a retracted position. By using more than 2 notches 124, second cutting element 106 can have various extension (or retraction) positions. While it is believed the elastic force supplied by arm 222 is sufficient to hold second cutting element 106 in place, notches 124 can be  
5 angled to inhibit inadvertent movement of slider 214.

Holder 220 holds second cutting element 106 in slider 214. Holder 220 can take many forms, such as, a "C" shaped cup that second cutting element 106 snaps into, a clamp, or the like. In the example shown, second cutting element 106 is a conventional razor. Thus, second cutting element 106 has a top edge  
10 232 that has a pair of channels 234 forming a pin 236. Holder 220 has a corresponding catch 238 that fits around pin 236 in channels 234 to hold second cutting element 106.

While the invention has been particularly shown and described with reference to an embodiment thereof, it will be understood by those skilled in the  
15 art that various other changes in the form and details may be made without departing from the spirit and scope of the invention.

We claim:

1. A utility knife, comprising:  
a handle;  
a first cutting element; and  
a second cutting element, wherein  
5 the handle comprises a body and a grip, the body having a first end, a second end, and at least one notch, the first end comprising a plurality of extensions forming a gap, the second end comprising a slot;  
the first cutting element being fixedly coupled to the first end such that the first cutting element resides in the gap formed by the plurality of extensions;  
10 the second cutting element being slidably coupled to the second end such that the second cutting element has at least one extended position and at least one retracted position; and  
the second cutting element being releasably coupled to the at least one notch, the at least one notch being located to hold the second cutting element in a  
15 position consisting of at least one of the at least one extended position and the at least one retracted position.
2. The utility knife according to claim 1, wherein the handle defines  
an internal space.  
20
3. The utility knife according to claim 2, further comprising:  
a first cutting element notch, the first cutting element notch resides in the  
internal space towards the first end such that only a portion of the first cutting  
element is exposed in the gap.  
25
4. The utility knife according to claim 2, further comprising:  
a second cutting element slide, the second cutting element slide resides in  
the internal space towards the second end;



the second cutting element is coupled to the second cutting element slide  
30 such that the second cutting element can move in the slot;

an arm having a first end connected to the second cutting element and a  
second end connected to a connector; the connector is coupled to the nub such  
that the connector is slidably received in the latch track, the arm is elastically  
deformable; and

35 at least one prong coupled to the arm, the at least one prong being  
releasably coupled to the at least one notch.

5. The utility knife according to claim 4, further comprising:  
a first cutting element notch, the first cutting element notch resides in the  
40 internal space towards the first end such that only a portion of the first cutting  
element is exposed in the gap.

6. The utility knife according to claim 1, wherein the first cutting  
element and the second cutting element are selected from the group of cutting  
45 elements consisting of a razorblade, a saw, a pick, an awl, and a wedge.

7. The utility knife according to claim 6, wherein the first cutting  
element and the second cutting element are the same type of cutting element.

50 8. The utility knife according to claim 2, further comprising:  
at least one space cutting element notch residing in the internal space.

9. The utility knife according to claim 2, further comprising:  
a second cutting element slide, the second cutting element slide resides in  
55 the internal space towards the second end;

a second cutting element holder slidably coupled to the second cutting  
element slide;

the second cutting element is coupled to the second cutting element holder such that the second cutting element can move in the slot along with the second cutting element holder;

60 an arm having a first end connected to the second cutting element holder and a second end connected to a connector; the connector is coupled to the nub such that the connector is slidably received in the latch track, the arm is elastically deformable; and

65 at least one prong coupled to the arm, the at least one prong being releasably coupled to the at least one notch.

10. The utility knife according to claim 9, wherein the second cutting element comprises a top edge having a plurality of channels forming at least one pin; and the second cutting element holder comprises a latch to fit snugly about the at least one pin to couple the second cutting element to the second cutting element holder.

11. The utility knife according to claim 9, wherein the second cutting element holder comprising a wall having a "C" shape such that the second cutting element snaps into the "C" shape.

12. A dual blade utility knife comprising:
- a handle;
  - 80 a first cutting edge;
  - a second cutting element;
  - an internal space;
  - an arm;
  - a connector;
  - 85 a nub; and
  - at least one prong, wherein
- the handle comprises a body and a grip, the body having a first end, a second end, a latch track, and at least one notch about the latch track, the first end comprising a plurality of extensions forming a gap, the second end
- 90 comprising a slot;
- the internal space is defined by the handle,
- the internal space comprising a first cutting edge notch towards the first end and a second cutting element slider towards the second end, wherein
- the first cutting edge being fixedly coupled in the first cutting edge notch
- 95 such that a portion of the first cutting edge resides in the gap formed by the plurality of extensions;
- the second cutting element being slidably coupled to the second cutting element slide such that the second cutting element has at least one extended position and at least one retracted position;
- 100 the arm having a first end coupled to the second cutting element and a second end coupled to the connector;
- the connector coupled to the nub and slidably received within the latch track; and
- the at least one prong coupled to second end of the arm and releasably
- 105 coupled to the at least one notch such that the second cutting element can move between at least one extended position and at least one retracted position.

110 13. The dual blade utility knife according to claim 12, wherein the first cutting edge is selected from the group consisting of a razorblade and a serrated blade.

115 14. The dual blade utility knife according to claim 13, wherein the second cutting element is selected from the group consisting of an awl, a pick, a wedge, a razorblade, and a serrated blade.

15. The dual blade utility knife according to claim 13, wherein the second cutting element is selected to be the same as the first cutting edge.

120 16. The dual blade utility knife according to claim 12, wherein the at least one notch comprises a plurality of notches and at least one notch corresponds to the extended position and the at least another notch corresponds to the retracted position.

125 17. The dual blade utility knife according to claim 16, wherein at least a third notch exists corresponding to a position selected from the group consisting of at least a partial extended position and a partial retracted position.

130 18. The dual blade utility knife according to claim 12, further comprising at least one spare storage notch.

19. A utility knife comprising:
- a handle, the handle comprising a body and a grip, the body having a first end and a second end;
  - a first cutting element coupled to the first end;
  - 5 a second cutting element coupled to the second end;
  - means for holding the first cutting element to provide a safety feature that inhibits accidents; and
  - means for moving the second cutting element from at least one extended position to at least one retracted position.

10

1/2

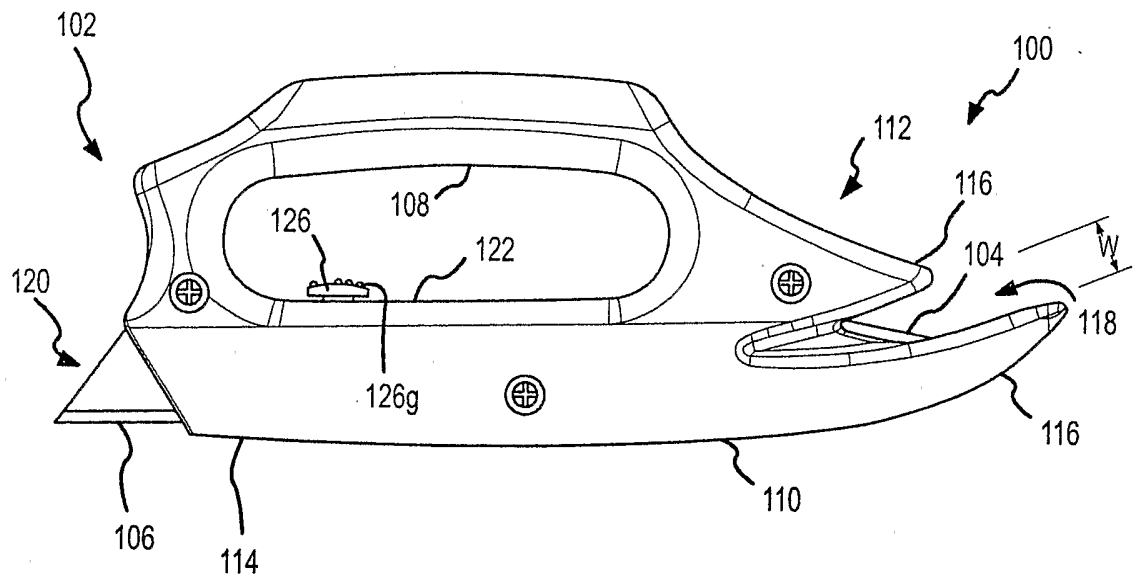

FIG. 1

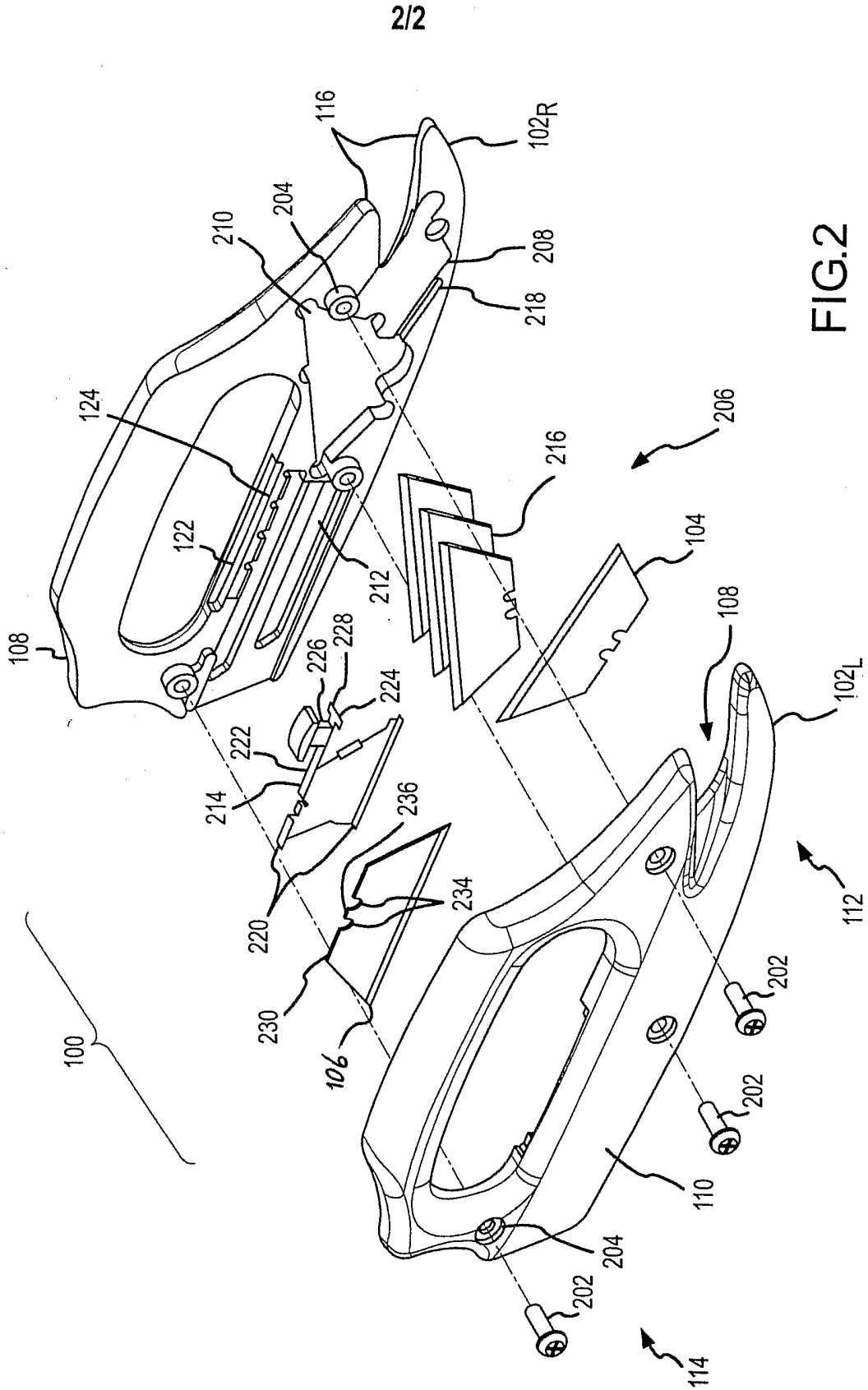

FIG.2

**INTERNATIONAL SEARCH REPORT**

International application No.

PCT/US04/27429

**A. CLASSIFICATION OF SUBJECT MATTER**

IPC(7) : B26B 1/08, 5/00  
 US CL : 30/294, 162, 299

According to International Patent Classification (IPC) or to both national classification and IPC

**B. FIELDS SEARCHED**

Minimum documentation searched (classification system followed by classification symbols)  
 U.S. : 30/294, 162, 299, 152, 143, 299.2, 287; 7/118, 158, 160

Documentation searched other than minimum documentation to the extent that such documents are included in the fields searched

Electronic data base consulted during the international search (name of data base and, where practicable, search terms used)

**C. DOCUMENTS CONSIDERED TO BE RELEVANT**

Category *	Citation of document, with indication, where appropriate, of the relevant passages	Relevant to claim No.
X	US 6,543,140 B1 (DAVIS) 08 APRIL 2003 (08.04.2003), see entire document.	1-3, 6-8, 19
A	US 4,974,320 A (PELLETIER) 04 DECEMBER 1990 (04.12.1990), see entire document.	1-19
A	US 3,748,742 A (BIGLER ET AL) 31 JULY 1973 (31.07.1973), see entire document.	1-19

<input type="checkbox"/> Further documents are listed in the continuation of Box C.	<input type="checkbox"/> See patent family annex.
* Special categories of cited documents:	"T" later document published after the international filing date or priority date and not in conflict with the application but cited to understand the principle or theory underlying the invention
"A" document defining the general state of the art which is not considered to be of particular relevance	"X" document of particular relevance; the claimed invention cannot be considered novel or cannot be considered to involve an inventive step when the document is taken alone
"E" earlier application or patent published on or after the international filing date	"Y" document of particular relevance; the claimed invention cannot be considered to involve an inventive step when the document is combined with one or more other such documents, such combination being obvious to a person skilled in the art
"L" document which may throw doubts on priority claim(s) or which is cited to establish the publication date of another citation or other special reason (as specified)	"&" document member of the same patent family
"O" document referring to an oral disclosure, use, exhibition or other means	
"P" document published prior to the international filing date but later than the priority date claimed	

Date of the actual completion of the international search 15 January 2005 (15.01.2005)	Date of mailing of the international search report <b>28 JAN 2005</b>
Name and mailing address of the ISA/US Mail Stop PCT, Attn: ISA/US Commissioner for Patents P.O. Box 1450 Alexandria, Virginia 22313-1450 Facsimile No. (703) 305-3230	Authorized officer Linda J Sholl <i>L. Hurley for</i> Telephone No. (571) 272-4391