

(19) World Intellectual Property Organization  
International Bureau



(43) International Publication Date  
18 June 2009 (18.06.2009)

PCT

(10) International Publication Number  
**WO 2009/076649 A2**

(51) International Patent Classification:  
*H04R 1/10* (2006.01)      *H04R 5/033* (2006.01)  
*H04R 1/02* (2006.01)

(21) International Application Number:  
PCT/US2008/086701

(22) International Filing Date:  
12 December 2008 (12.12.2008)

(25) Filing Language: English

(26) Publication Language: English

(30) Priority Data:  
61/012,974      12 December 2007 (12.12.2007)      US

(71) Applicant and

(72) Inventor: SEMCKEN, Kevin R. [US/US]; 9500 W. 49th Avenue, Unit B-100, Wheat Ridge, Colorado 800333 (US).

(74) Agent: LENZEN, Glenn H.; Shughart Thomson & Kilroy, P.C., 1050 17th Street, Suite 2300, Denver, Colorado 80265 (US).

(81) Designated States (unless otherwise indicated, for every kind of national protection available): AE, AG, AL, AM, AO, AT, AU, AZ, BA, BB, BG, BH, BR, BW, BY, BZ, CA, CH, CN, CO, CR, CU, CZ, DE, DK, DM, DO, DZ, EC, EE, EG, ES, FI, GB, GD, GE, GH, GM, GT, HN, HR, HU, ID, IL, IN, IS, JP, KE, KG, KM, KN, KP, KR, KZ, LA, LC, LK, LR, LS, LT, LU, LY, MA, MD, ME, MG, MK, MN, MW, MX, MY, MZ, NA, NG, NI, NO, NZ, OM, PG, PH, PL, PT, RO, RS, RU, SC, SD, SE, SG, SK, SL, SM, ST, SV, SY, TJ, TM, TN, TR, TT, TZ, UA, UG, US, UZ, VC, VN, ZA, ZM, ZW.

(84) Designated States (unless otherwise indicated, for every kind of regional protection available): ARIPO (BW, GH, GM, KE, LS, MW, MZ, NA, SD, SL, SZ, TZ, UG, ZM, ZW), Eurasian (AM, AZ, BY, KG, KZ, MD, RU, TJ, TM), European (AT, BE, BG, CH, CY, CZ, DE, DK, EE, ES, FI, FR, GB, GR, HR, HU, IE, IS, IT, LT, LU, LV, MC, MT, NL, NO, PL, PT, RO, SE, SI, SK, TR), OAPI (BF, BJ, CF, CG, CI, CM, GA, GN, GQ, GW, ML, MR, NE, SN, TD, TG).

Published:  
— without international search report and to be republished upon receipt of that report

(54) Title: HEADPHONE APPARATUS

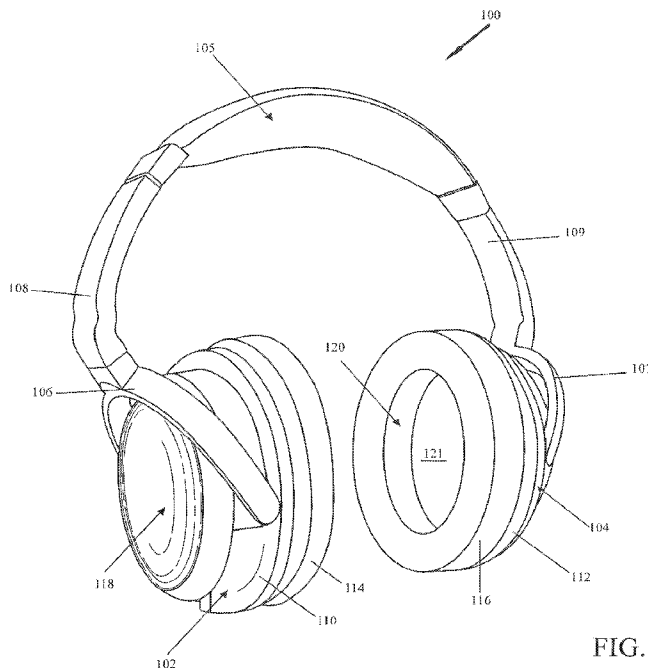

FIG. 1

(57) Abstract: A single chamber headphone apparatus and earcup design is provided which enhances wearer comfort, reduces headphone weight, facilitates ease of use, maintenance and operation by providing an improved internal chamber and battery cap configuration. Sound quality is improved by eliminating acoustic problems associated with two-chamber headset designs. A volume balance control is also provided.

WO 2009/076649 A2

## HEADPHONE APPARATUS

### PRIORITY TO RELATED APPLICATIONS

**[0001]** This application claims the benefit of U.S. Provisional Application No. 61/012974, filed December 12, 2007, the entire contents of which are incorporated herein by reference

### FIELD OF THE INVENTION

**[0002]** The present invention relates to headphones or headsets generally, and, more particularly, to an improved headphone apparatus and earcup design which enhances wearer comfort, reduces headphone weight, facilitates ease of use, maintenance and operation by providing an improved internal chamber and battery cap configuration. The headphone apparatus of the present invention improves sound quality by eliminating acoustic problems associated with two-chamber headset designs. A volume balance control is also provided.

### BACKGROUND OF THE INVENTION

**[0003]** Recent advances in sound transmission technology have led to the development of new headphones or headsets for use in telecommunications and entertainment applications in both external environments, such as military field operations, and internal environments, such as home use for listening to music and/or radio and television broadcasts. Headsets normally include one or a pair of earcups which fit over the outer ear and which are held in place by hand or by means of a head band which extends over the top of or behind the wearer's head. In addition to sound quality, wearer comfort is of primary concern to the user, particularly if the headphones are to be worn over an extended time period.

**[0004]** Headphone designs intended to improve both headphone sound quality and wearer comfort are disclosed in U.S. Patent No. 4,455,675 issued to Bose et al, June 19, 1984 and in U.S. Patent No. 4,644,581 issued to Sapiejewski, February 17, 1987. The headphones which are the subject of those disclosures include headphone cavities and electroacoustical transducers such as pressure-sensitive microphones

positioned within the cavities respectively for providing signals which correspond to the sum of external noise and the sound produced by the headphone driver in each cavity. These designs include internal circuitry which reduces noise and distortion and improves the quality of the sound output to the ear and a cushion in contact with the ear to enhance wearer comfort.

**[0005]** More recently, U.S. patent No. 4,922,542 issued to Sapiejewski, May 1, 1990 discloses a headphone in which each earcup includes a baffle which supports a driver for converting an electrical input signal into an acoustical output signal to the ear. The baffle defines an inner and an outer cavity, the outer cavity being positioned adjacent the wearer's ear and encompassed by a cushion surrounding the outer ear and sealing the outer cavity from the surrounding external environment. Similarly, U.S. Patent No. 5,181,252 issued to Sapiejewski et al., January 19, 1993 discloses a headphone having a high compliance driver mounted on a baffle which divides the headphone earcup into two chambers, each chamber having a preselected compliance which is individually matched to the compliances of the other chamber and the driver respectively to maximize the quality of the acoustical output. U.S. Patent No. 7,412,070 issued to Kleinschmidt et al., August 12, 2008 discloses a headphone having a pair of earcups, each earcup having a loudspeaker driver located off-center in an internal cavity. However, the designs of the '542, the '252 and the '070 disclosures do not adequately address the problems associated with acoustic interference and cancellation phenomenon associated with multi-chamber headphone designs, nor do they address the problem of volume balance control.

**[0006]** The headphone design of the present invention overcomes these and other problems by providing a new and novel headphone design which eliminates the internal acoustical compliance-related issues associated with a multi-chamber headphone earcup construction and a volume balance control feature which will permit the wearer to selectively psychoacoustically calibrate, adjust and balance the sound volume in each earcup. More specifically, the present invention provides a single chamber earcup having the microphone and driver mounted inside the earcup in such a manner that the baffle is eliminated, thereby permitting free flow of air throughout the

entire cavity formed by the back of the earcup and the side of the wearer's head. Means are provided to support the driver and the microphone at a predetermined location within the earcup that is sufficiently removed from the wearer's outer ear to prevent damage to the microphone which could result from contact with the pinna and during the process of putting on and/or removing the headphones, yet which is sufficiently close to the ear canal to maximize the quality of the sound delivered to the eardrum. An improved battery cover or cap is also provided.

#### BRIEF DESCRIPTION OF THE DRAWINGS

[0007] Fig. 1 is a perspective view of a headset according to an embodiment of the present invention;

[0008] Fig. 2 is a perspective view of a microphone and driver mounting apparatus according to an embodiment;

[0009] Fig. 3 is a perspective view of a microphone and driver mounting apparatus according to another embodiment;

[0010] Fig. 4 is a perspective view of a microphone and driver mounting apparatus according to yet another embodiment;

[0011] Fig. 5 is a perspective view of a microphone and driver mounting apparatus according to still another embodiment;

[0012] Fig. 6 is a plan view of a microphone and driver mounting apparatus according to another embodiment;

[0013] Fig. 7 is a side cross-sectional view of the microphone and driver mounting apparatus of the embodiment of Fig. 6;

[0014] Fig. 8 is a perspective view of a free flow protective cover according to an embodiment;

[0015] Fig. 9 is a front perspective view of a battery cap according to an embodiment;

[0016] Fig. 10 is a rear perspective view of the battery cap of Fig. 9;

[0017] Fig. 11 is a rear plan view of the battery cap of Figs. 9 and 10;

[0018] Fig. 12 is a plan view of a battery compartment according to an embodiment;

[0019] Fig. 13 is an enlarged partial sectional view of a portion of the battery compartment of Fig. 12;

[0020] Fig. 14 is a front perspective view of a battery cap according to another embodiment;

[0021] Fig. 15 is a rear perspective view of the battery cap of Fig. 14;

[0022] Fig. 16 is a side elevational view of a sound volume balance control in accordance with an embodiment;

[0023] Fig. 17 is a top plan view of the sound volume balance control of Fig. 16;

[0024] Fig. 18 is a rear elevational view of the sound volume balance control of Figs. 16 and 17; and

[0025] Figs. 19 and 20 are front and rear perspective views of the sound volume balance control of Figs. 16-18.

#### DESCRIPTION OF THE INVENTION

[0026] Before proceeding with the detailed description, it should be noted that the present teaching is by way of example, not by limitation. The concepts presented herein are not limited to use or application with one specific type of headphone or earcup design. Thus, although the instrumentalities described herein are for the convenience of illustration and explanation, shown and described with respect to

exemplary embodiments, the principles disclosed herein may be applied to other types and applications of headphone and earcup apparatus.

[0027] Referring now to Fig. 1, a headphone or headset apparatus is illustrated in perspective and includes a pair of headphones (also known in the art as earphones) **102** and **104** adapted to fit over a user's left and right outer ears (not shown). The earphones are pivotally connected to one another by an adjustable headband **105** adapted to fit over the top of a wearer's head, the headband having a wishbone-shaped yoke member **106, 107** secured at each end thereof for pivotally connecting the earphones to the headband. The headband comprises a pair of overlapping members **108, 109** which are slideably juxtaposed one on top of the other for adjustment to fit the wearer's head size. While in the embodiment shown, the headband is positioned over the top of the head, the headband alternatively could be of the behind-the-neck design without departing from the scope of the instant invention.

[0028] Each headphone includes an earcup **110, 112** pivotally mounted to the yoke members **106, 107** respectively, each earcup also having a cushion **114, 116** secured circumferentially thereto and adapted to fit over the wearer's left and right outer ears for comfort purposes, particularly during extended periods of wear. Earcup **110** also includes a battery cap **118** detachably secured thereto to contain one or more batteries in a battery compartment (not shown) formed in the earcup outer shell. The earcups each form an internal chamber, one of which is shown at **120**, which is adapted to fit over the wearer's outer ear and which contains the electronics, circuitry, microphones, and at least one speaker, diaphragm and associated driving member for operation of the headset and the transformation of electrical signals into acoustical signals for transmission to the left and right inner ear canals of the wearer. Typically, a protective membrane or screen **121** is disposed over the microphone to keep dirt and other foreign matter from being deposited in the chamber, which could be deleterious to the operation of the headset.

[0029] A diaphragm and driver assembly **125** is illustrated generally in Fig. 2 in accordance with one embodiment of the instant invention. The assembly includes a

diaphragm **126** coupled to a driver **128** and means for mounting the assembly in the internal chamber of the earcup. In the embodiment of Fig. 2, the driver is secured by arm **129** to a frame **130** for mounting inside an earcup **110**, **112** of Fig. 1. The frame **130** includes a generally circumferentially-shaped outer annular portion **132** adapted to be fitted into the earcup **110**, **112**, an inner ring **134** to which the arm **129** and the driver assembly **125** are connected, and a plurality of spokes or arm members **136** disposed axially about the ring element and connected at a first end thereto. The spokes extend radially outwardly from the inner ring and are each connected at a second end to the outer annular portion **132** of the frame **130**, the entire assembly being mounted inside the earcup. Bushings **137** are selectively formed on several of the spokes **136** and positioned circumferentially around the ring **134** for receiving mounting screws to secure protective cover over the diaphragm, as will hereinafter be discussed in greater detail.

**[0030]** The spaces **138** formed intermediate each spoke provide for the free flow of air and acoustic energy from the area in the chamber behind the diaphragm to the portion of the chamber positioned between the diaphragm and the outer ear. Hence, the acoustic problems associated having to match and balance the compliances of the speaker and of each of the inner and outer chambers formed by the baffles found in the prior art two-chamber headphones is eliminated, there being only a single chamber having a single compliance value in the exemplary headphone/earcup design of the present invention.

**[0031]** In another embodiment of the present invention illustrated in Fig. 3, the assembly includes a diaphragm **126'** mounted to a driver **128'** which is secured by arm **129'** to a frame **130'** for mounting inside an earcup **110**, **112** of Fig. 1. Similar in construction to the embodiment of Fig. 2, the frame **130'** includes a generally circumferentially-shaped outer annular portion **132'** adapted to be fitted into the earcup **110**, **112**, an inner ring **134'** to which the arm **129'** and the driver assembly **125'** are connected, and a plurality of spokes or arm members **136'** disposed axially about the ring element and connected at a first end thereto. In this embodiment, the spokes **136'** are in the form of rigid, thin wires, much like bicycle spokes, which provide even

greater spaces **138'** intermediate each spoke, thus enhancing the single chamber effect.

[0032] Fig. 4 illustrates the embodiment of Fig. 3 further including supporting grid or framework **140** which is disposed immediately adjacent to and behind the frame **130'** to provide additional structural support thereto. This additional support may be beneficial in holding the diaphragm **126'** and frame **130'** in position as the headphones are either placed upon or removed from a wearer's head.

[0033] Yet another embodiment of the present invention is shown in Fig. 5 in which the frame **130"** supporting the diaphragm or driver assembly **126"** includes an outer annular ring **130"** which is connected to an inner ring **134"** by a maze structure **136"**. The maze structure contains irregularly shaped, spaced-apart slots **138"** which eliminate the two chamber configuration of the prior art, provide additional support for the driver assembly **125"** and further, collimate the air flow and sound or acoustic energy uniformly as it passes from the area behind the driver assembly to the listener's ear.

[0034] Fig. 6 depicts yet another embodiment of a diaphragm and driver assembly 142 in which the supporting frame **130, 130', 130"** of the earlier embodiments is completely eliminated. In this embodiment, a diaphragm **144** and driver **146** are supported by arm **148** which is connected to a table assembly **150** mounted in the inner chamber of the earcup, as more clearly shown in Fig. 7.

[0035] Moving to Fig. 7, table assembly **150** is mounted by legs **152** to an internal element of the headphone shell (not shown), by way of example, in the instant embodiment, a battery box **154**, which contains the headphone batteries. A PCB board **156** containing the circuitry and electronics for the operation of the headphone assembly may optionally be mounted intermediate the battery box and the table assembly; however, it may be located elsewhere within or external to the structure in accordance with space limitations and the overall configuration of the headphone shell design. A protective flow-free cover or cap **158** may also be mounted over the table assembly to protect the speaker and driver mechanism, as hereinabove described



with respect to the supporting grid of the embodiment of Fig. 4. The protective cover **158** is illustrated in greater detail in Fig.8 and includes a plate member **160** in which are formed a plurality of holes or apertures **162** to permit free flow of sound from the speaker to the user's inner ear canal.

**[0036]** Referring now to Figs. 9 through 15, various embodiments of the battery cap **118** of fig. 1 are shown in greater detail. The battery cap includes a body portion **119** adapted to be removably mounted over a battery compartment or box (element **154** in Fig. 7) typically formed in or secured to the earcup **110**. While in the embodiment shown, the body portion is generally oval or elliptically-shaped, it is to be understood that the configuration is shown for purposes of illustration only, and that other shapes and configurations may be used without departing from the scope of the present invention. The body portion includes an outer surface **122** in which is formed a speaker aperture **123** and an inner surface **124** adapted to fit over the battery compartment **154** in the ear cup. In the embodiment shown, the inner and outer surfaces are generally curvilinear in shape to conform to the overall shape of the ear cup for aesthetic reasons

**[0037]** The inner surface **124** of the battery cap **118** is illustrated in greater detail in Figs.10 and 11 and includes at least one reinforcing rib **127** formed integrally therewith or affixed thereto to stiffen the cap. In the embodiment shown, the cap also includes at least one upper lug **131** positioned on and secured to or formed integrally with an upper or first end portion **135** of the inner surface of the battery cap and at least one lower lug **133** positioned on and secured to or formed integrally with a lower or second end portion **139** of the inner surface of the battery cap.

**[0038]** Each of the upper and lower lugs are adapted to be removably received in a corresponding aperture **141**, **143** respectively formed in the earcup shell **110**, as shown in greater detail in Figs.12 and 13. Each of the upper lugs **131** includes an elongate body element **145** which is adapted to be received, aligned and retained in position by a corresponding elongate segment **147** of the apertures **141** and **143** respectively. The upper lugs each further include an angular end portion **149** which extends radially inwardly from the elongated body element and is adapted to provide

an interference fit with the apertures **141** and **143** to hold the battery cap in position on the ear cup. In the embodiment of Figs. 10 and 11, the angular end portion is shown to extend inwardly at an angle of approximately 45 degrees from the axis of the elongated body element. However, it is to be understood that the angle is not critical to the overall functioning of the lug and other angles may be used with equal effectiveness, depending upon the configuration of the ear cup and battery cap designs. By way of example, Figs. 14 and 15 depict yet another embodiment of the instant invention wherein the angular end portions **149'** are formed at substantially right angles to the elongated body elements **145'**.

**[0039]** Referring now to Figs. 10 and 14, each of the lower lugs **133** includes a tapered member **151** which extends generally laterally outwardly from the lug from the lower end **139** of the battery cap **118** in a direction toward the upper end **135** of the battery cap in a direction substantially parallel with the plane of the inner surface **124**. Each of the tapered members **151** form a space **153** intermediate the inner surface **124** of the battery cap and the tapered member. Each of the spaces is structured and arranged to removably fit over an upper edge **155** of each of the apertures **143**, thereby locking the battery cap in place on the ear cup during operation by a wearer. To remove or change out the batteries (not shown), a user may simply depress the lower portion **139** of the battery cap to disengage it and thereafter slide it off the ear cup. To replace the battery cap on the ear cup, the upper and lower lugs are simply positioned within their respective receiving apertures and the battery cap is pushed under slight pressure toward the upper portion of the ear cup to lock it in place.

**[0040]** Referring to Figs. 16 – 20, means for selectively psychoacoustically calibrating, adjusting and balancing the sound volume in each earcup is shown generally at **200**. For purposes of simplicity, the means **200** will be referred to herein and in the appended claims as either balancing means or balance control device. The balancing means is designed to permit a wearer of the headphone apparatus who has monaural hearing loss to selectively increase sound volume directed to an ear having hearing loss without increasing sound volume directed to an ear having no

hearing loss, thereby avoiding potential damage to and resulting hearing loss in the ear having normal hearing.

**[0041]** The balance control device **200** includes a housing or body member **202** having a clip or fastener **204** affixed thereto to permit the wearer to attach the device to his or her belt or other clothing. The device is operatively connected to the headphone apparatus by cables or conductors **206, 208** extending from each end thereof. Control elements **210, 212** and **214** are adapted to turn the device on and off and to selectively calibrate, adjust and balance the sound volume directed to each headphone. In an embodiment, a calibration device (not shown) is incorporated into or operatively coupled to the balance control device and structured and arranged to provide clear sound tones in the sound transmission that are perfectly centered or balanced as intended by the composer of the original transmission. The headphone user then may reset the center point in response to the wearer's psychoacoustic perception of centered, balanced sound volume; and lock the balance control at the wearer's psychoacoustically perceived center, whereby all sounds subsequently delivered to the headphone apparatus will be calibrated to the balance of the original sound transmission.

**[0042]** Changes may be made to the above methods, systems, devices and structures without departing from the scope hereof. It should be noted that the matter contained in the above description and/or shown in the accompanying drawings should be interpreted as illustrative and not in a limiting sense. The following claim(s) are intended to cover all generic and specific features described herein as well as statements of the scope of the present invention, which, as a matter of language, might be said to fall therebetween.

## CLAIMS

### WHAT IS CLAIMED IS:

1. A headphone apparatus comprising:
  - a pair of earphones, each earphone including an earcup, each earcup having an outer shell defining an internal chamber adapted to fit over a wearer's right and left outer ears respectively;
  - electronics, circuitry, microphones, at least one speaker including a diaphragm and associated driving members mounted in the internal chamber for operation of the headphone and the transformation of electrical signals into acoustical signals for transmission to the left and right inner ear canals of the wearer;
  - means for mounting the driver and driving member in the internal chamber;
  - an adjustable headband adapted to fit a user's head and having a first and second end portion, each end portion including a yoke member secured thereto, each yoke member being structured and arranged to pivotally mount one of the earcups respectively;
  - a battery compartment formed in the outer shell of at least one of the earcups;
  - a battery cap detachably secured to the outer shell for containing at least one battery in the battery compartment; and
  - means for detachably securing the battery cap to the outer shell.
  
2. The headphone of claim 1 wherein the driver mounting means comprises an arm secured to a frame adapted to be mounted inside the inner chamber, the frame including a generally circumferentially-shaped outer annular portion adapted to be fitted into the earcup, an inner ring element connected to the arm and the driver assembly, and a plurality of arm members disposed axially about the ring element and having first and second end portions, the first end portion being connected to the ring element, and the second end portion being connected to the frame.
  
3. The headphone of claim 2 wherein the arm members define a plurality of spaces, the spaces being structured and arranged to permit the free-flow of acoustic

energy from an area in the inner chamber located behind the diaphragm to the portion of the chamber positioned between the diaphragm and the outer ear.

4. The headphone of claim 2 wherein the arm members comprise wire spokes.
5. The headphone of claim 4 further including a supporting framework structured and arranged to provide structural support to the wire spokes.
6. The headphone of claim 1 wherein the driver mounting means comprises a maze structure having a plurality of irregularly shaped, spaced apart slots structured and arranged to collimate air flow and acoustic energy as it passes from an area in the inner chamber located behind the diaphragm to the portion of the chamber positioned between the diaphragm and the outer ear.
7. The headphone of claim 1 wherein the driver mounting means comprises a table assembly mounted in the inner chamber of the earcup.
8. The headphone assembly of claim 7 including a printed circuit board containing the circuitry and electronics for the operation of the headphone assembly mounted intermediate the battery compartment and the table assembly.
9. The headphone assembly of claim 1 wherein the battery cap includes a body portion adapted to be removably mounted over the battery compartment, the body portion including an outer surface having a speaker aperture formed therein and an inner surface adapted to fit over the battery compartment.
10. The headphone assembly of claim 9 wherein the battery cap includes at least one reinforcing rib affixed thereto.
11. The headphone assembly of claim 9 further including at least one upper lug positioned on a first end portion of the inner surface and at least one lower lug positioned on a second end portion of the inner surface of the battery cap, each of

the at least one upper and lower lugs being adapted to be removably received in a corresponding aperture formed in the earcup.

12. The headphone of claim 1 including means for selectively psychoacoustically calibrating, adjusting and balancing the sound volume in each earcup.

13. The headphone of claim 12 wherein the volume balancing means includes a control device adapted to permit a wearer having monaural hearing loss to selectively increase sound volume directed to an ear having hearing loss without increasing sound volume directed to an ear having no hearing loss.

14. The headphone of claim 12 wherein the balancing means includes a calibration device adapted to provide clear, centered sound tones, the calibration device being operatively connected to the balancing means whereby the wearer may selectively adjust and set a perceived sound balance center point psychoacoustically in response to the wearer's level of hearing loss.

15. A method for balancing sound volume in a headphone apparatus having a pair of headphones adapted to fit over a wearer's right and left outer ears respectively, the method comprising:

- coupling a volume balance control device to the headphone apparatus;
- operatively connecting a calibration device to the balance control device, the calibration device being adapted to provide true centered volume of a sound transmission to each of the headphones;
- resetting the center point in response to the wearer's psychoacoustic perception of centered, balanced sound volume; and
- locking the balance control at the wearer's psychoacoustically perceived center, whereby all sounds subsequently delivered to the headphone apparatus will be calibrated to the balance of the original sound transmission.

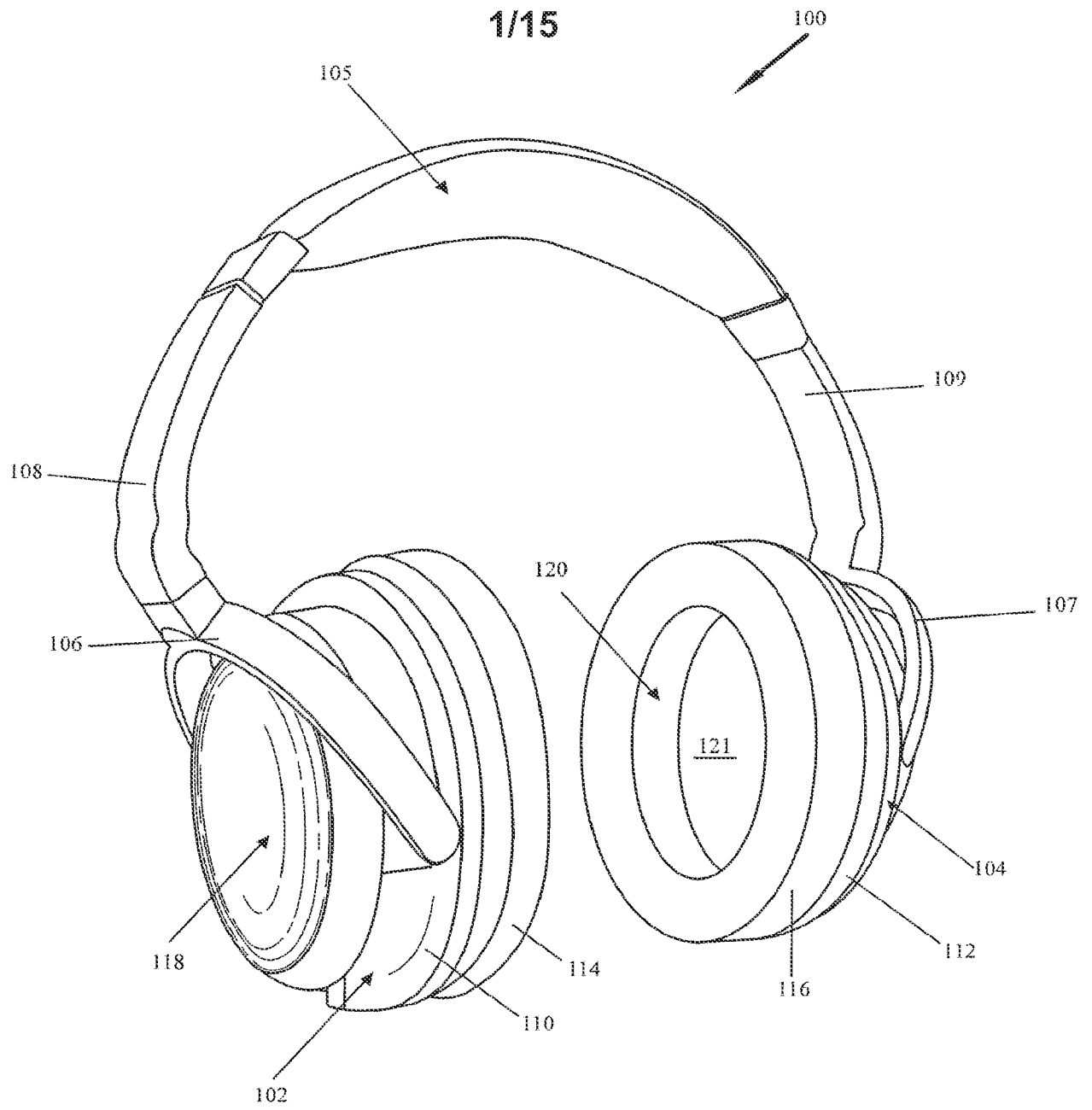

FIG. 1

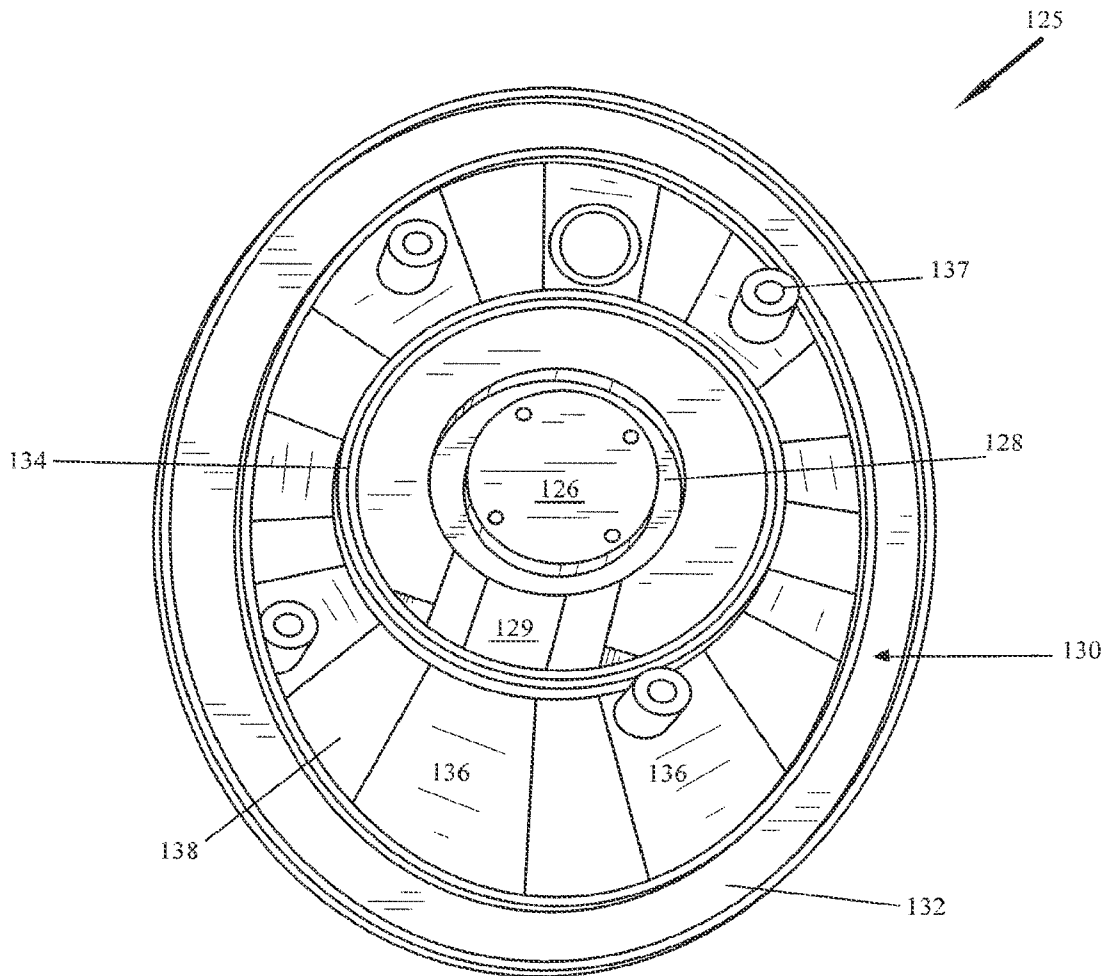

FIG. 2



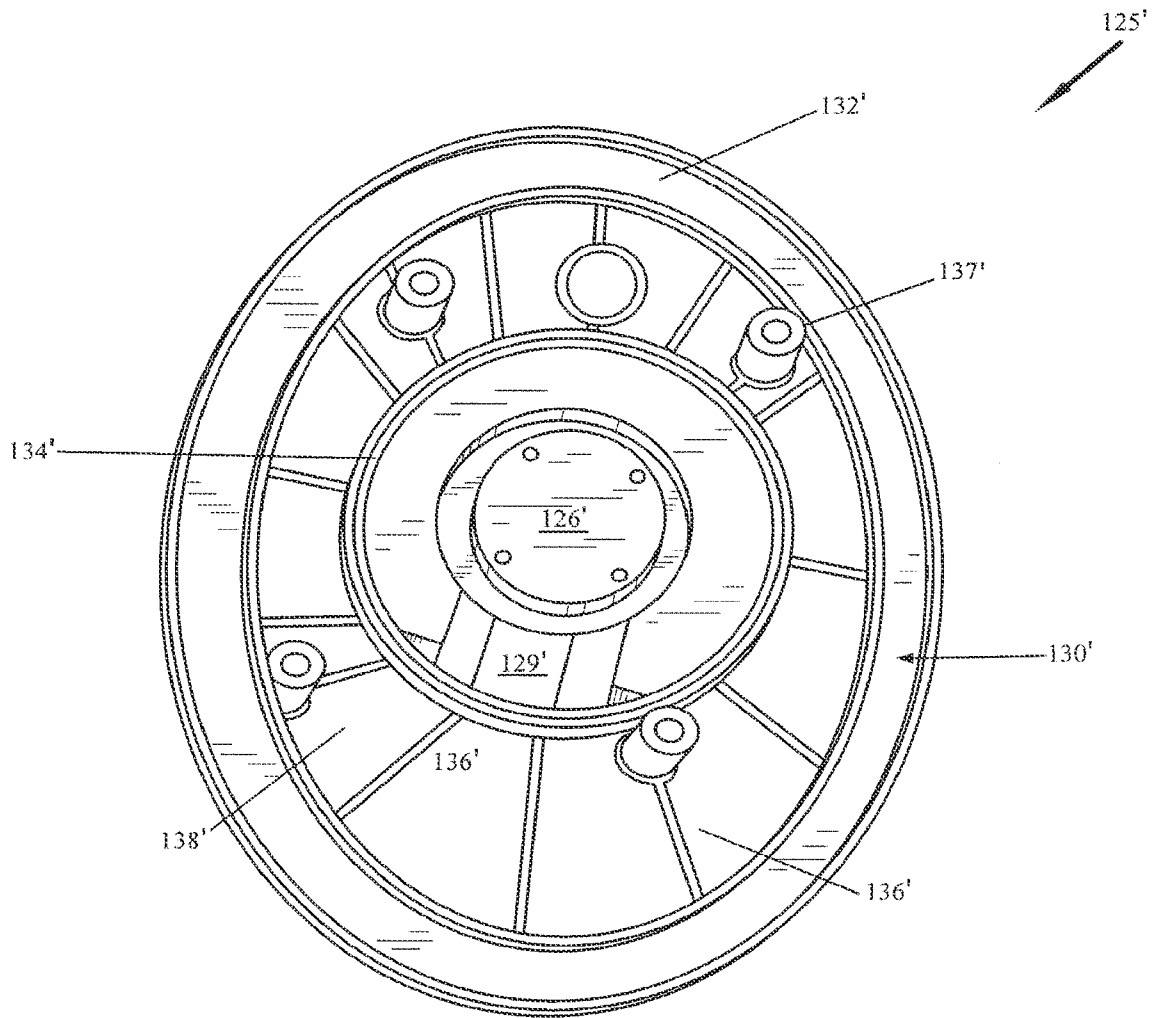

FIG. 3

4/15

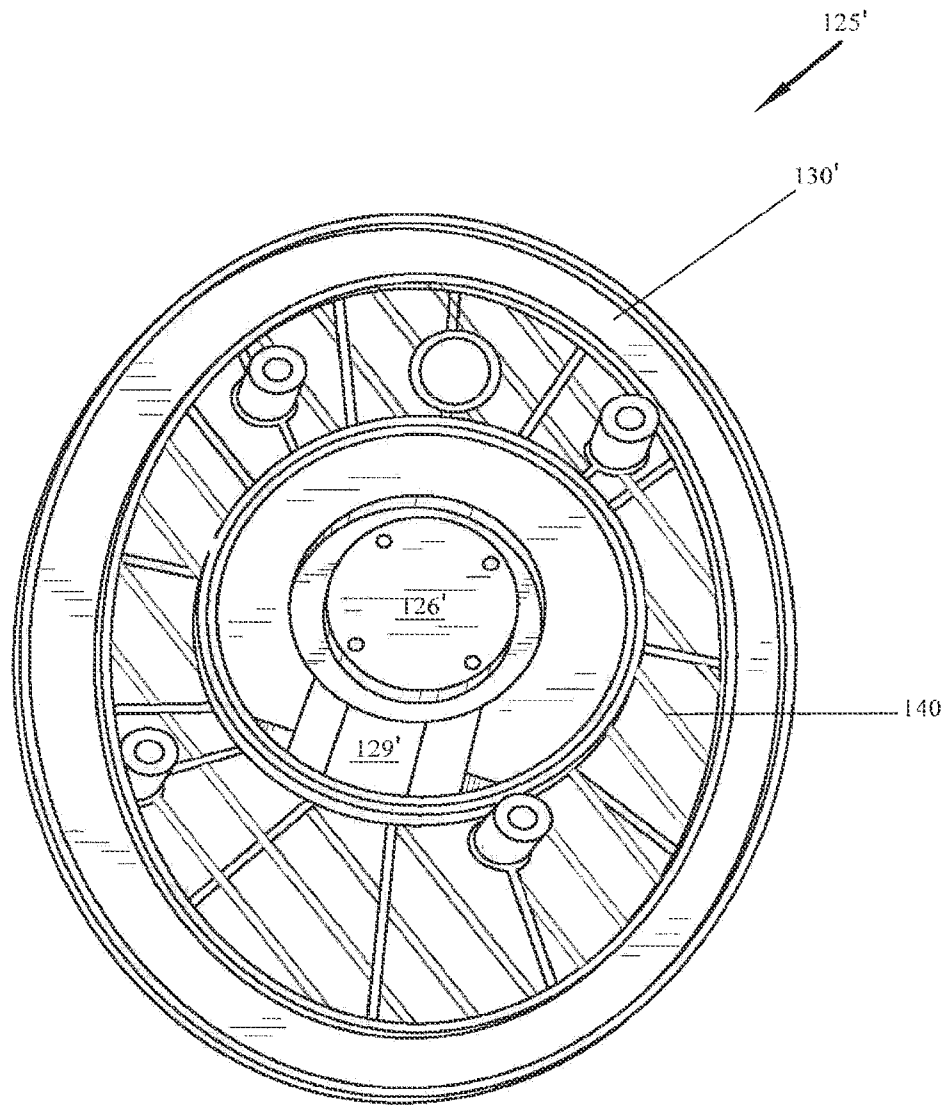

FIG. 4

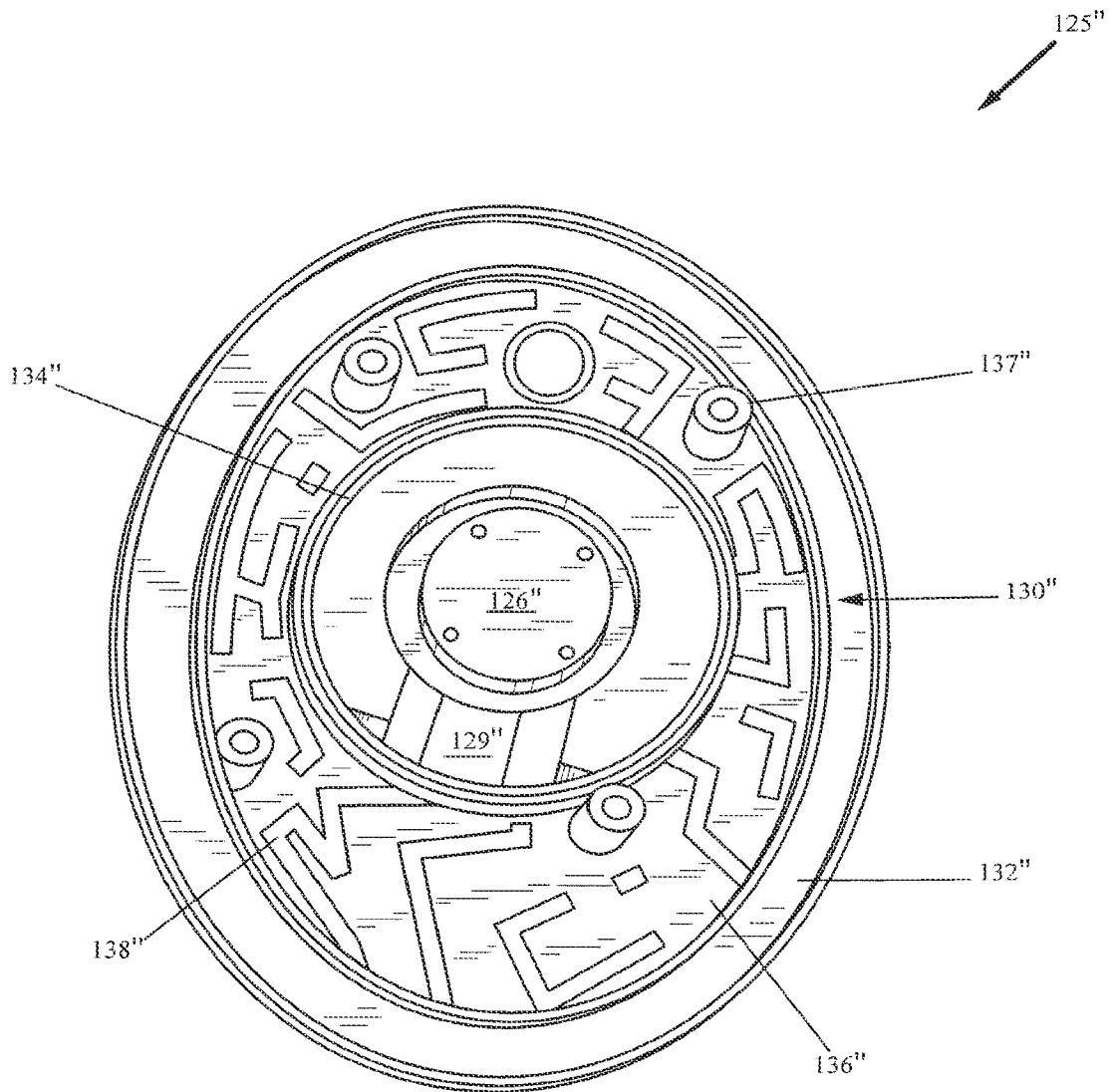

FIG. 5

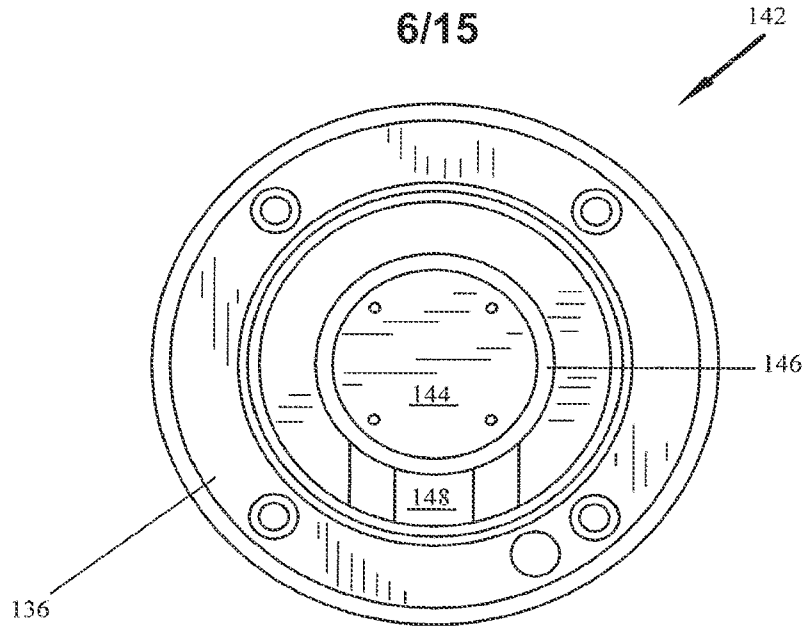

FIG. 6

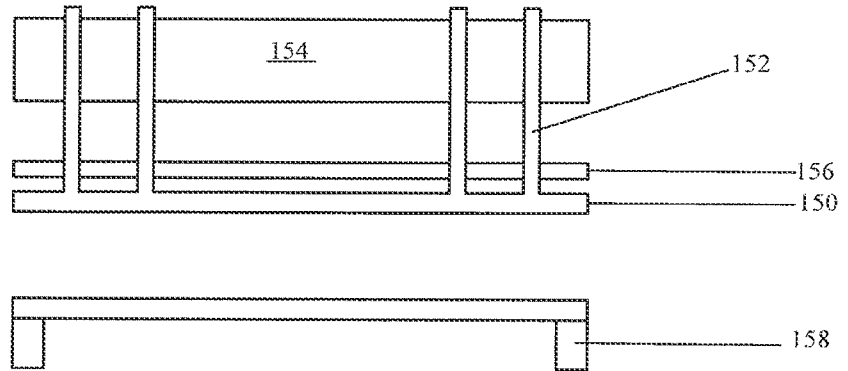

FIG. 7

7/15

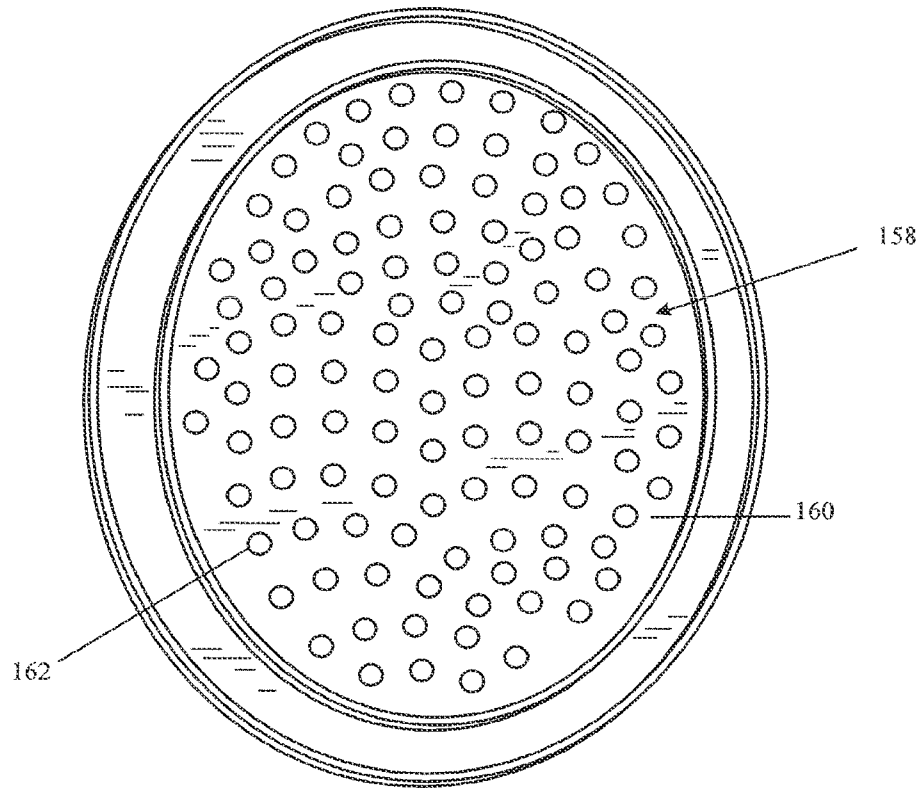

FIG. 8

8/15

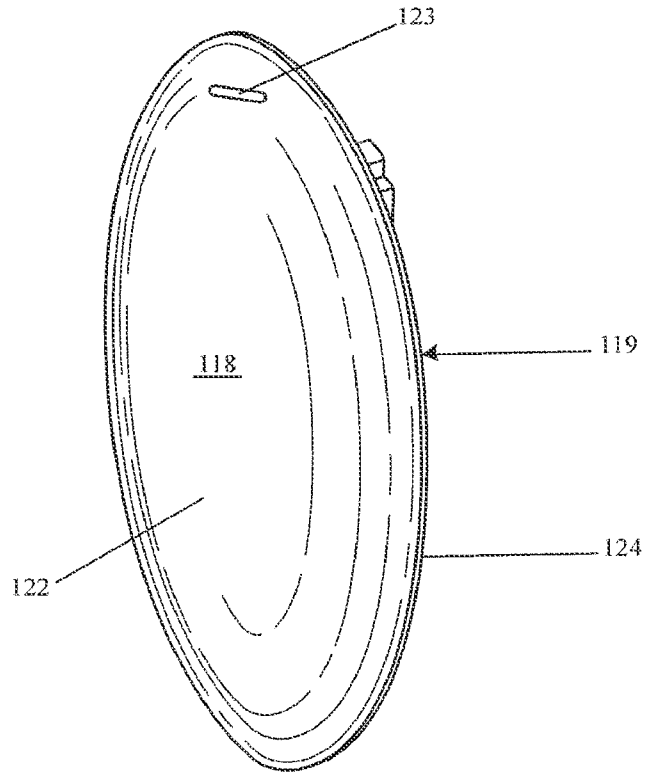

FIG. 9

9/15

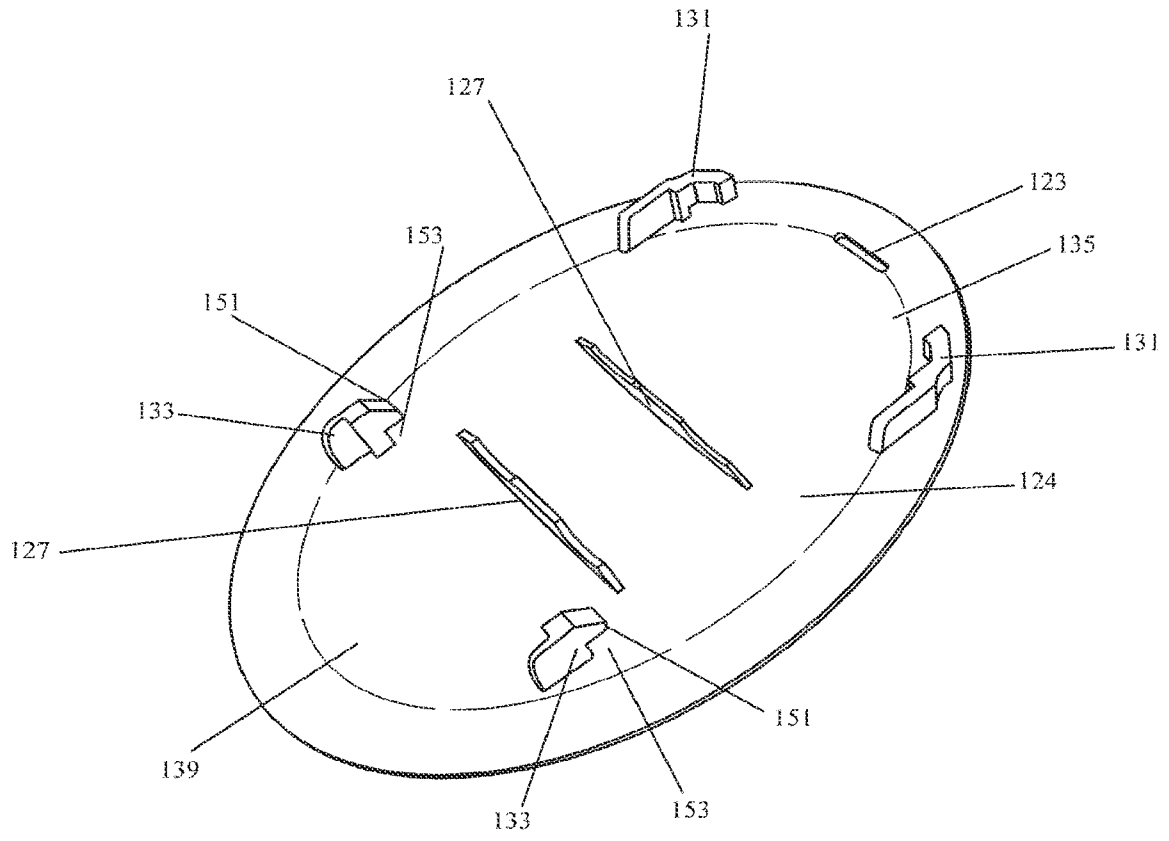

FIG. 10

10/15

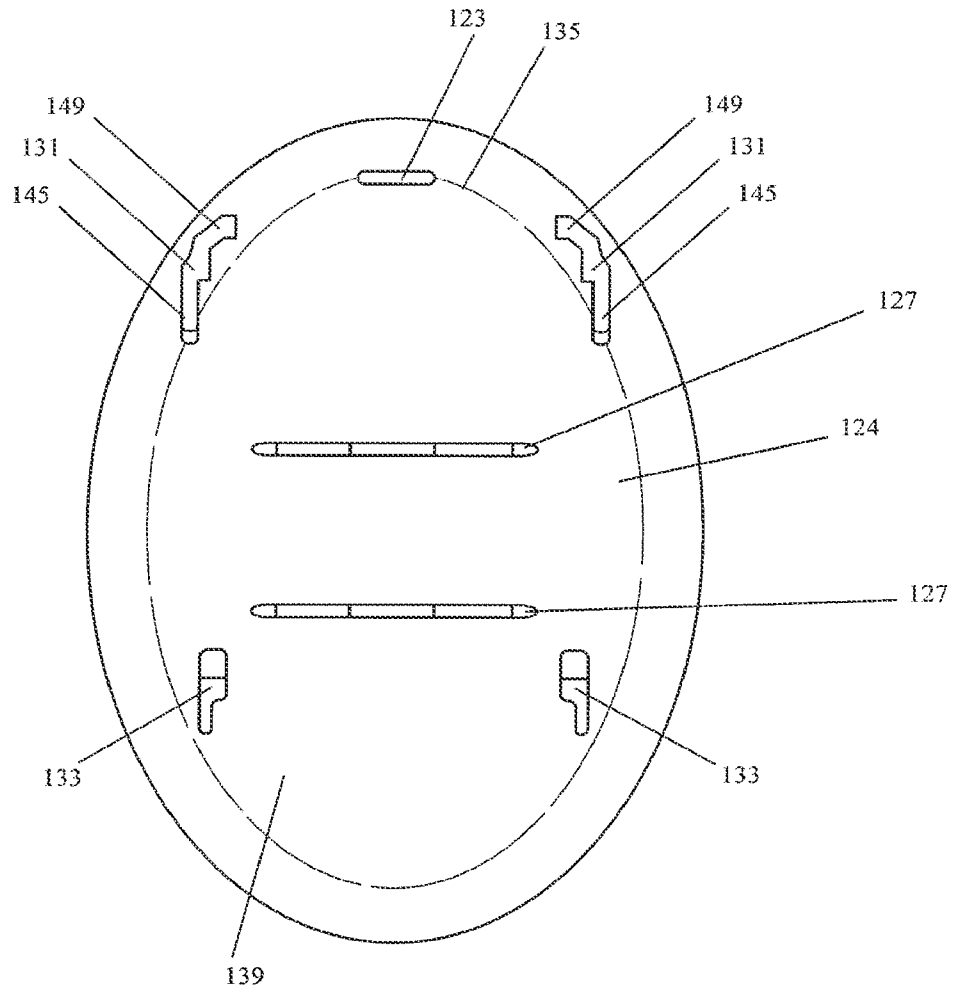

FIG. 11



11/15

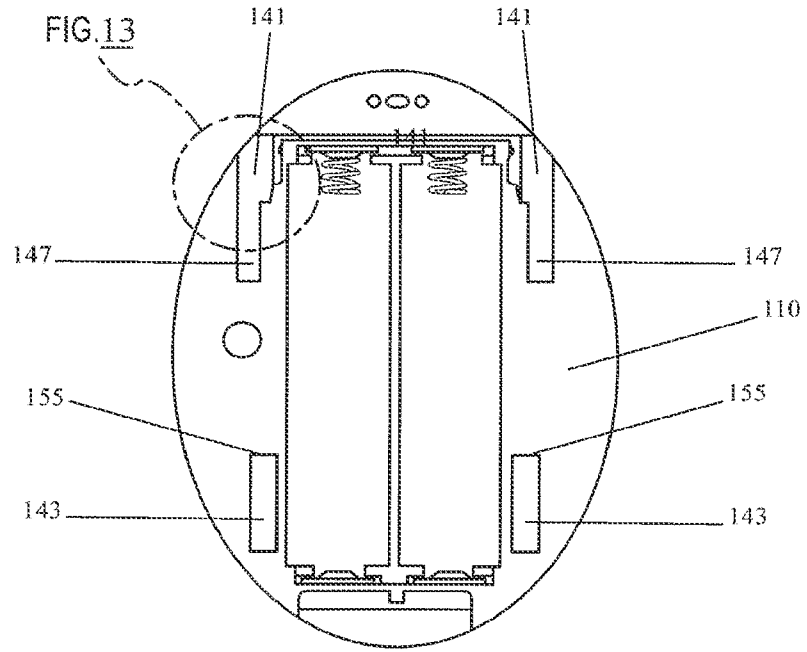

FIG. 12

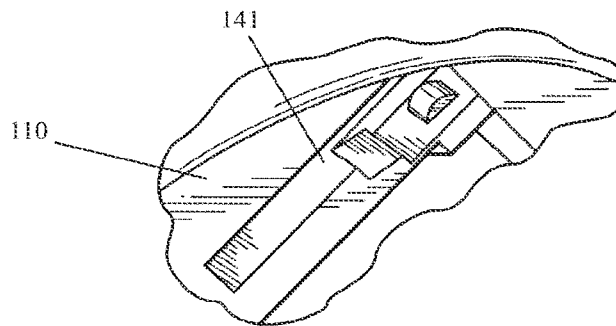

FIG. 13

12/15

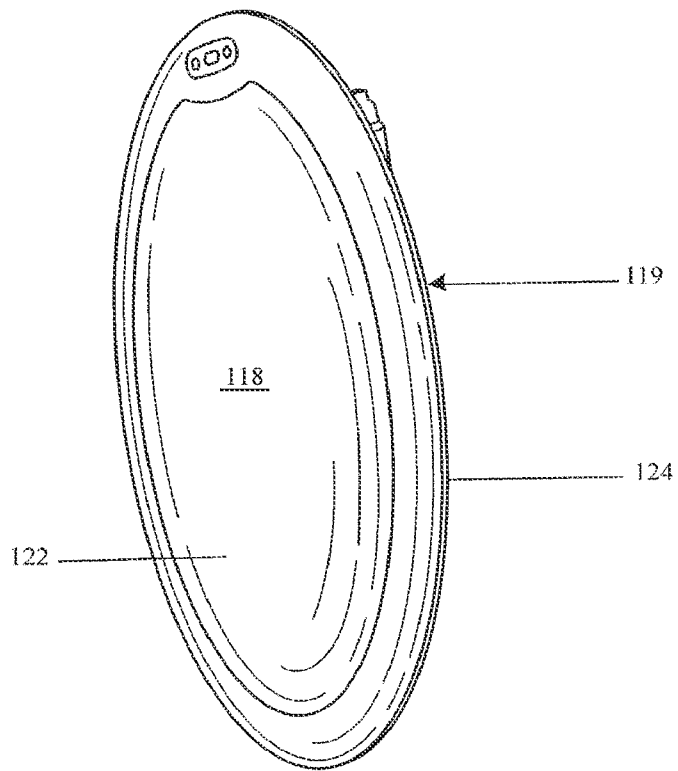

FIG. 14

13/15

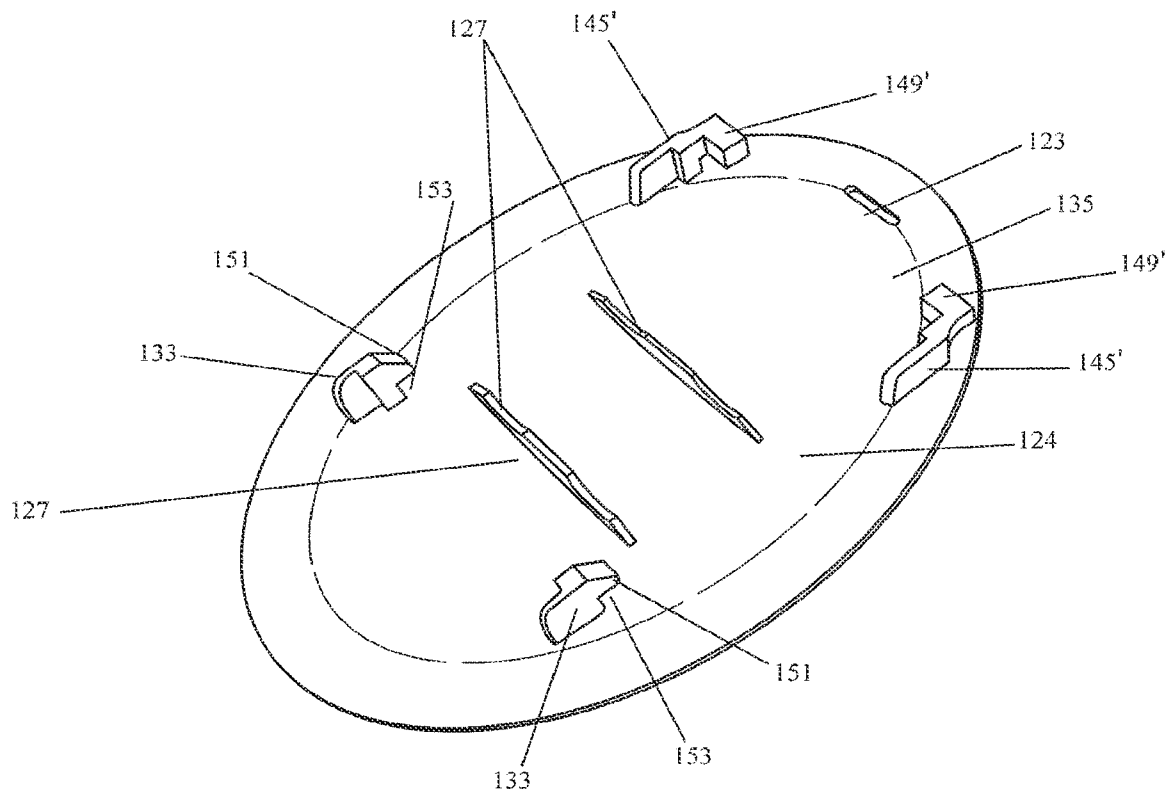

FIG. 15

14/15

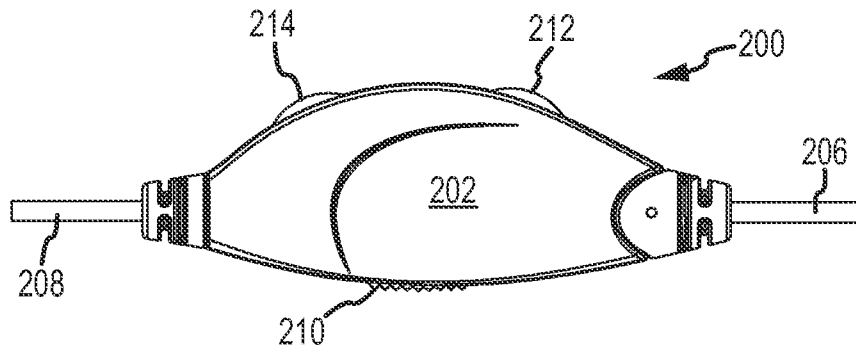

FIG. 16

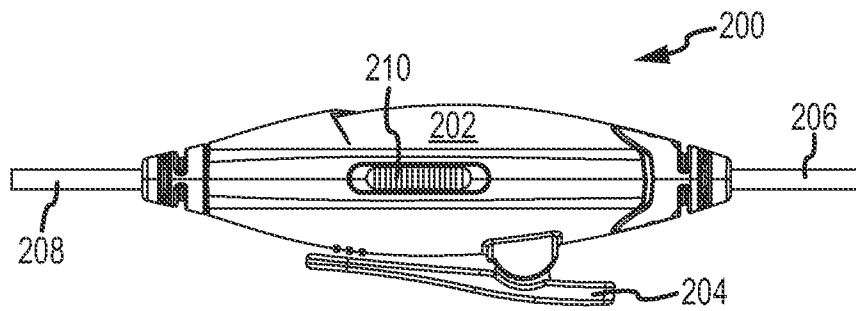

FIG. 17

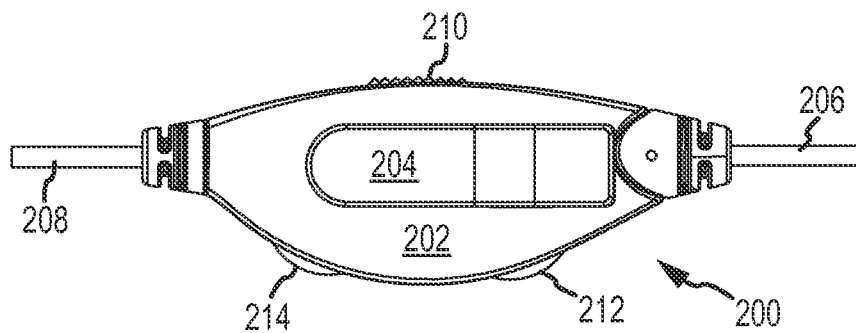

FIG. 18

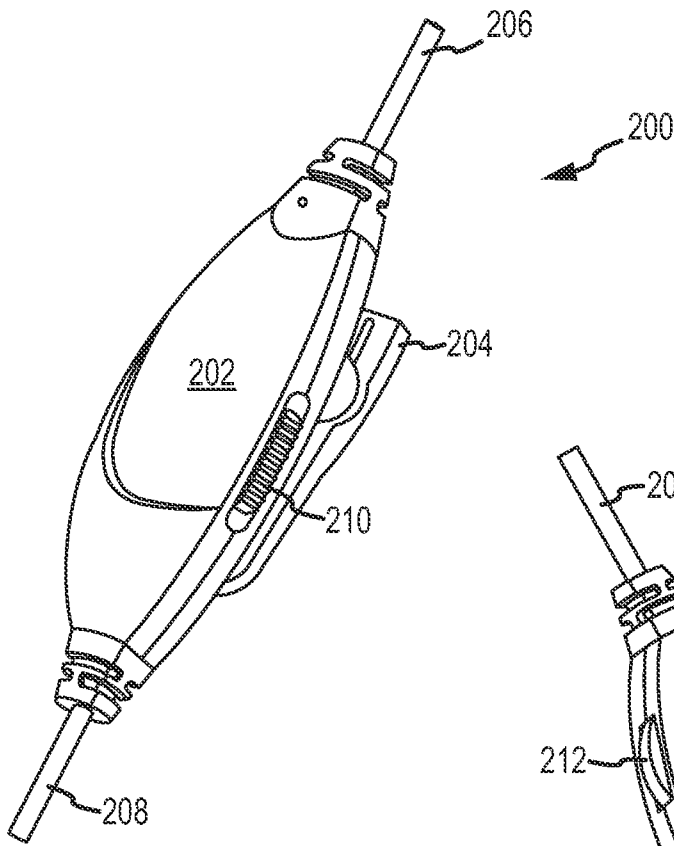

FIG. 19

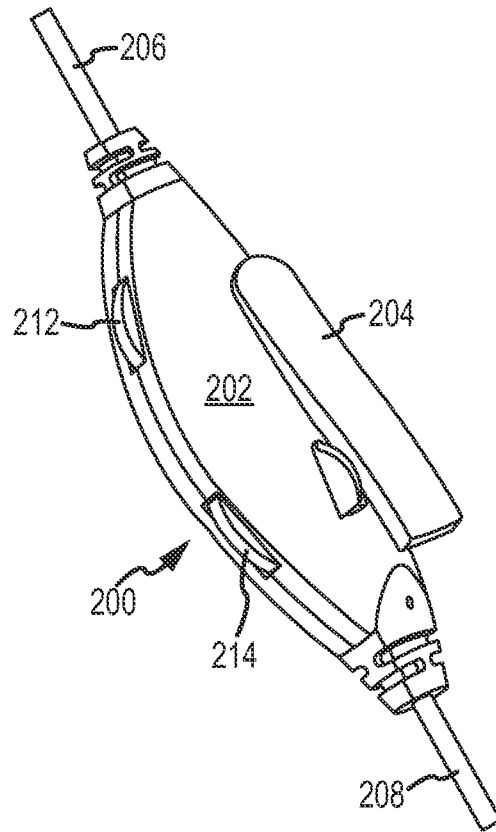

FIG. 20