

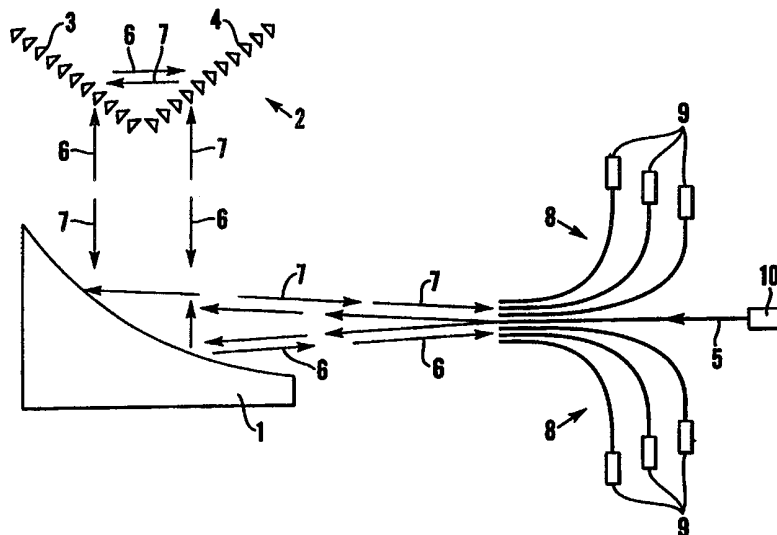

INTERNATIONAL APPLICATION PUBLISHED UNDER THE PATENT COOPERATION TREATY (PCT)

<p>(51) International Patent Classification⁶ : G02B 6/122</p>	<p>A1</p>	<p>(11) International Publication Number: WO 99/60433</p> <p>(43) International Publication Date: 25 November 1999 (25.11.99)</p>
<p>(21) International Application Number: PCT/GB99/01288</p> <p>(22) International Filing Date: 26 April 1999 (26.04.99)</p> <p>(30) Priority Data: 9810705.5 19 May 1998 (19.05.98) GB</p> <p>(71) Applicant: BOOKHAM TECHNOLOGY LIMITED [GB/GB]; 90 Milton Park, Abingdon, Oxon OX14 4RY (GB).</p> <p>(72) Inventor: ASGHARI, Mehdi; 53 Godolphin Close, Freshbrook, Swindon SN5 8RN (GB).</p> <p>(74) Agents: UNWIN, Stephen, Geoffrey et al.; Fry, Heath & Spence, The Old College, 53 High Street, Horley, Surrey RH6 7BN (GB).</p>		<p>(81) Designated States: AU, CA, CN, IL, JP, KR, SG, European patent (AT, BE, CH, CY, DE, DK, ES, FI, FR, GB, GR, IE, IT, LU, MC, NL, PT, SE).</p> <p>Published <i>With international search report.</i></p>

(54) Title: OPTICAL DEVICE FOR SPLITTING UP A MULTI-WAVELENGTH LIGHT BEAM



(57) Abstract

An optical device for splitting up a multi-wavelength light beam into a plurality of individual beams each comprising light of a different wavelength or a narrow band of wavelengths. The optical device includes an optical grating (2) and an optical system (1) for directing the incident beam onto the optical grating (2). The incident beam is divided into two portions and one portion is directed onto the grating (2) in one direction and the other portion onto the grating (2) in the opposite direction. Preferably, the grating (2) is formed in two parts (3, 4) and one beam portion is directed through the two grating parts (3, 4) in succession in one direction and the other beam portion is directed through the two grating parts (3, 4) in succession in the opposite direction. A common mirror (1) may be used to direct light towards the grating (2) and to receive light returning from the grating (2). The device may also be used as a multiplexer by reversing the direction of light transmitted through the device.

FOR THE PURPOSES OF INFORMATION ONLY

Codes used to identify States party to the PCT on the front pages of pamphlets publishing international applications under the PCT.

AL	Albania	ES	Spain	LS	Lesotho	SI	Slovenia
AM	Armenia	FI	Finland	LT	Lithuania	SK	Slovakia
AT	Austria	FR	France	LU	Luxembourg	SN	Senegal
AU	Australia	GA	Gabon	LV	Latvia	SZ	Swaziland
AZ	Azerbaijan	GB	United Kingdom	MC	Monaco	TD	Chad
BA	Bosnia and Herzegovina	GE	Georgia	MD	Republic of Moldova	TG	Togo
BB	Barbados	GH	Ghana	MG	Madagascar	TJ	Tajikistan
BE	Belgium	GN	Guinea	MK	The former Yugoslav Republic of Macedonia	TM	Turkmenistan
BF	Burkina Faso	GR	Greece	ML	Mali	TR	Turkey
BG	Bulgaria	HU	Hungary	MN	Mongolia	TT	Trinidad and Tobago
BJ	Benin	IE	Ireland	MR	Mauritania	UA	Ukraine
BR	Brazil	IL	Israel	MW	Malawi	UG	Uganda
BY	Belarus	IS	Iceland	MX	Mexico	US	United States of America
CA	Canada	IT	Italy	NE	Niger	UZ	Uzbekistan
CF	Central African Republic	JP	Japan	NL	Netherlands	VN	Viet Nam
CG	Congo	KE	Kenya	NO	Norway	YU	Yugoslavia
CH	Switzerland	KG	Kyrgyzstan	NZ	New Zealand	ZW	Zimbabwe
CI	Côte d'Ivoire	KP	Democratic People's Republic of Korea	PL	Poland		
CM	Cameroon	KR	Republic of Korea	PT	Portugal		
CN	China	KZ	Kazakstan	RO	Romania		
CU	Cuba	LC	Saint Lucia	RU	Russian Federation		
CZ	Czech Republic	LI	Liechtenstein	SD	Sudan		
DE	Germany	LK	Sri Lanka	SE	Sweden		
DK	Denmark	LR	Liberia	SG	Singapore		
EE	Estonia						

OPTICAL DEVICE
FOR SPLITTING UP A MULTI- WAVELENGTH LIGHT BEAM

TECHNICAL FIELD

The present invention relates to an optical device for splitting up a multi-wavelength light beam into a plurality of individual beams each comprising light of a different wavelength or a narrow band of wavelengths. Such a device is commonly called a de-multiplexer.

BACKGROUND PRIOR ART

It is known to use an optical transmission grating to split up a multi-wavelength beam of light into individual beams of light of different wavelengths or narrow bands of wavelengths. Such a device comprises a first optical system, for example a mirror, for directing the multi-wavelength beam onto the grating. On passing through the grating the multi-wavelength beam is split into individual beams of light of different wavelengths or narrow bands of wavelengths emerging from the grating at different angles. The individual beams are passed to a second optical system, for example another mirror, which directs each individual beam into a respective individual waveguide or other optical path device. In such a device the light passes through each of two optical systems once and the grating once.

It is also known to use an optical reflection grating formed on the surface of a mirror to split up a multi-wavelength beam of light.

The object of the present invention is to provide an improved optical device for splitting up a multi-wavelength beam of light into a plurality of individual beams each comprising light of a different wavelength or a narrow band of wavelengths.

SUMMARY OF THE INVENTION

According to a first aspect of the invention there is provided an optical device for splitting up a multi-wavelength light beam into a plurality of individual beams of light of different wavelengths or narrow bands of wavelengths comprising:

an optical grating, and

an optical system for directing an incident multi-wavelength light beam onto the grating so that a first portion of the light beam passes through the grating in one direction and is split into a first set of individual light beams of different wavelengths or narrow bands of wavelengths and a second portion of the light beam passes through the grating in the opposite direction and is split into a second set of individual light beams of different wavelengths or narrow bands of wavelengths.

According to another aspect of the invention there is provided an optical device for splitting up a multi-wavelength light beam into a plurality of individual beams of light of different wavelengths or narrow bands of wavelengths comprising:

an optical grating having a first part and a second part, and

an optical system for directing an incident multi-wavelength light beam onto the grating so that the incident beam passes through the two parts of the grating in succession and the two parts of the grating act in succession on the incident light beam to split the incident light beam into a set of individual beams of light of different wavelengths or narrow bands of wavelengths.

According to a preferred embodiment of the invention the optical grating has a first part and a second part, and

the optical system is arranged to direct a first portion of the incident beam onto the first part of the grating, and a second portion of the incident beam onto the second part of the grating,

the optical grating being constructed so that the first portion of the incident beam, on leaving the first part of the grating, is transmitted to the second part of the grating and the two parts of the grating split the first portion of the incident beam into a first set of individual beams of different wavelengths or narrow bands of wavelengths, and so that

the second portion of the incident beam, on leaving the second part of the grating, is transmitted to the first part of the grating and the two parts of the grating split the second portion of the incident beam into a second set of individual beams of different wavelengths or narrow bands of wavelengths.

Thus, in this preferred embodiment, the incident multi-wavelength light beam is effectively divided into two portions, each of these portions being directed through two parts of an optical grating in succession, with the two portions being directed through the two parts of the grating in opposite directions.

The optical grating may be either a transmission grating or a reflection grating and it should be noted that references herein to light passing "through" a grating are to be interpreted as either light passing from one side to the other side of a transmission grating or light being incident upon one side of a reflection grating and returning from that side of the grating.

References herein to individual beams of light of different wavelengths or narrow bands of wavelengths should be interpreted as covering both discrete beams of light and a continuous spectrum of light which can be regarded as comprising a series of adjacent beams of light.

The optical device is referred to above for splitting up a multi-wavelength beam into a plurality of individual beams, i.e. when used as a de-multiplexer. The same apparatus may also be used as a multiplexer by reversing the direction of transmission of light through the device and this invention covers the device whether for use as a de-multiplexer or as a multiplexer.

Preferred or optional features of the invention will be apparent from the following description and from the subsidiary claims of the specification.

In order that the invention may be more readily understood embodiments will now be described, merely by way of example, with reference to the accompanying drawings in which:

BRIEF DESCRIPTION OF THE DRAWINGS

Figure 1 is a schematic diagram of an optical device in accordance with a first embodiment of the invention including an optical transmission grating illustrating how the device is used to divide an incident multi-wavelength beam of light into two portions and to pass the two portions through the transmission grating so as to split up each portion into individual beams,

Figure 2 is a schematic diagram showing how a first portion of the incident multi-wavelength beam passes in one direction through the optical transmission grating in the optical device of Figure 1,

Figure 3 is a schematic diagram showing how a second portion of the incident multi-wavelength beam passes in the opposite direction through the optical transmission grating in the optical device of Figure 1,

Figures 4 and 5 are schematic diagrams illustrating the construction of the optical transmission grating in the optical device of Figure 1,

Figure 6 is a schematic diagram illustrating the construction of an optical reflection grating,

Figure 7 is a schematic diagram showing an optical device in accordance with a second embodiment of the invention and including an optical reflection grating as illustrated in Figure 6,

Figure 8 is a schematic diagram of an optical device in accordance with a third embodiment of the invention and using an optical reflection grating as illustrated in Figure 6,

Figure 9 is a schematic diagram of an optical device in accordance with a fourth embodiment of the invention using a chirped grating,

Figure 10 is an enlarged schematic diagram of part of an optical device in accordance with a fifth embodiment of the invention,

Figure 11 is a schematic diagram of an optical device according to a sixth embodiment of the invention, and

Figure 12 is a schematic diagram of an optical device according to a seventh embodiment of the invention.

BEST MODE OF THE INVENTION

The invention relates to an optical device for splitting up a multi-wavelength light beam into a plurality of individual beams each comprising light of a different wavelength or a narrow band of wavelengths. The optical device includes an optical grating (2) and an optical system (1) for directing the incident beam onto the optical grating (2).

The incident beam is divided into two portions and one portion is directed onto the grating (2) in one direction and the other portion onto the grating (2) in the opposite direction. Preferably, the grating (2) is formed in two parts (3,4) and one beam portion is directed through the two grating parts (3,4) in succession in one direction and the other beam portion is directed through the two grating parts (3,4) in succession in the opposite direction. A common mirror (1) may be used to direct light towards the grating (2) and to receive light returning from the grating (2).

A grating comprising a single part may also be used, the arrangement being such that a first portion of the beam passes through the grating in one direction and a second portion of the beam passes through the grating in the opposite direction. The arrangement may be similar to that shown in the Figures but with one of the grating parts replaced by a mirror, or other reflecting device, perpendicular to the plane of the replaced grating part. Such an arrangement is more compact than the prior art.

With reference to Figure 1, the optical device comprises a concave mirror 1, shown in end view, and an optical transmission grating 2 which comprises two parts 3, 4. An incident multi-wavelength divergent beam of light 5, eg from a superluminescent diode (SLD) 10, is directed to the surface of the mirror 1. On reflection at the surface of the mirror 1 the multi-wavelength beam of light is collimated and, by the positioning of the mirror 1 relative to the grating 2, is effectively divided into two portions and passed to the optical transmission grating 2.

One portion 6 of the collimated multi-wavelength beam passes through the left hand (as viewed in the Figure) part 3 of the grating 2 where it is split into a first set of individual beams of different wavelengths or narrow bands of wavelengths. On leaving the left hand part 3 of the grating this first set of individual beams is directed towards the right hand (as viewed in the Figure) part 4 of the grating 2 which splits these individual beams further and then directs them back to the mirror 1.

The other portion 7 of the collimated multi-wavelength composite beam passes through the right hand (as viewed in the Figure) part 4 of the grating 2 where it is split into a second set of individual beams of different wavelengths or narrow bands of wavelengths. On leaving the right hand part 4 of the grating this second set of individual beams is directed towards the left hand (as viewed in Figure 3) part 3 of the grating 2 which splits these beams further and then directs them back to the mirror 1.

The resolution of the multi-wavelength incident light beam into individual light beams is thus increased by passing the incident beam through two optical transmission gratings in succession.

By reflection at the mirror 1 the two sets of individual beams are focussed and directed to a set of receiving waveguides 8 arranged so that each individual beam is received in a respective waveguide. The multi wavelength beam is thus split into individual beams of light of different wavelength or wavelengths by the grating 2 and each individual beam is focussed at a different point by the mirror 1 so that, with appropriate positioning of the receiving waveguides 8, each receives a respective one of the individual beams. The geometry of the optical systems is preferably arranged so that light of the same wavelength in the two portions of the beam is re-combined and directed to the same output waveguide. Thus, the two portions of the beam are re-combined so they spatially coincide.

The optical paths through the optical device of Figure 1 of the two portions 6, 7 of the incident multi-wavelength light beam are shown more clearly in Figures 2 and 3, which illustrate the optical paths of the portions 6 and 7 respectively. It will be appreciated that each portion 6, 7 of the multi-wavelength light beam passes through the two parts 3, 4 of the grating 2 in succession, one portion 6 travelling in a clockwise direction as shown in Figure 2 and the other portion 7 travelling in an anticlockwise direction as shown in Figure 3. Nevertheless, as indicated above, the arrangement is such that light of a given wavelength or narrow wavelength band is received by the same receiving waveguide 8 whichever way it has passed around this optical circuit.

The two parts 3, 4 of the optical transmission grating 2 are designed to split up the incident multi-wavelength light beam into individual beams as required. The construction of the grating is shown on a larger scale in Figures 4 and 5. Figure 4 is a plan view of the part 3 of the grating 2 and shows how the grating is formed from a linear array of generally triangular recesses 11 in a layer 13 of transparent material such as silicon, for instance, on a silicon-on-insulator chip. The recesses 11 are spaced by distances d_1 , d_2 , d_3 etc. Figure 5 is a cross-sectional view along line B-B in Figure 4 showing how the recesses 11 extend through the

silicon layer 13 of a silicon-on-insulator chip. The part 4 of the grating 2 (not illustrated) is formed in a similar way. The two parts 3, 4 of the grating 2 are preferably formed adjacent each other so they meet at a point as shown.

As illustrated in Figures 2 and 3, the array of recesses 11 forming the part 3 of the grating 2 extends along an axis 14 and the array of recesses forming the part 4 of the grating 2 extends along an axis 15. The two axes 14, 15 are inclined at an angle A to each other so that each portion 6, 7 of the incident multi-wavelength composite beam, on passing through one of the parts 3, 4 of the grating 2, is directed to the other part and, on passing through the other part, is then directed back to the mirror 1, as illustrated.

As described above, the mirror 1 re-directs light returning from the grating 2 to light receiving means such as a series of receiving waveguides 8 which, in turn, lead to respective light sensors 9. The waveguides 8 may, for instance, comprise a series of integrated rib waveguides each positioned to receive a respective wavelength beam as the beams return from the mirror at different angles depending upon their wavelength having undergone dispersion in the grating 2. The rib waveguides 8 direct the beams to respective light sensors 9 such as photodiodes. Alternatively, the waveguides 8 may be replaced by an array of optical fibres (as described further below in relation to Fig. 10), or may lead to an array of optical fibres.

In another arrangement, the geometry of the optical system may be arranged so that the two portions of the beam travelling in opposite directions through the grating are not re-combined, e.g. if one portion is used to monitor the output of the light source. Such an arrangement is described below in relation to Figure 10.

The arrangement shown in Figure 1 increases dispersion of the incident beam by passing each portion of the beam through the two parts of the grating in succession. Also, the arrangement shown in Figure 1 is compact, as the beam is divided into two portions which are passed through the two parts of the grating in opposite directions to each other. The illustrated arrangement also provides

considerable space saving by using the same mirror to direct light towards the grating and to receive light returning therefrom. Furthermore, as the dispersion is increased, the distance between the receiving waveguides 8 and the grating 2 can be reduced as the required separation between the beams of different wavelengths is achieved over a shorter distance.

In addition to saving space, the reduction in the number of components also simplifies fabrication of the device, as the fewer the components, the lower the risk that a faulty component will impair performance of the device. The production yield of a device comprising a small number of components such as shown in Figure 1 is thus likely to be higher and so leads to savings in production costs as compared to known arrangements using a plurality of mirrors.

The optical devices illustrated in the Figures may be formed on an optical chip, such as a silicon-on-insulator (SOI) chip. An SOI chip enables easy integration of the various components of the device and relatively low fabrication costs. Further details of SOI chips and of rib waveguides formed thereon are given in WO 95/08787.

Methods of mounting components such as photodiode detectors (as shown in Figure 1) on a silicon-on-insulator chip are described in GB 2307786A and in GB 2315595A.

The incident multi-wavelength beam may be provided by a broadband source, such as a long coherence length SLD, which may also be mounted or hybridised on an silicon-on-insulator chip as described in GB2307786A and in GB2315595A. The incident multi-wavelength beam may also be received from another source, eg from an external source connected to the waveguide 5 by an optical fibre.

The construction and operation of an optical transmission grating 2 comprising a linear array of recesses 11 by electron beam or photolithographic techniques are well known and will not be described in detail. As illustrated in Figures 4 and 5 each recess 11 is formed with two surfaces 21, 22 extending generally at right angles to each other and connected by a third surface 23. The portion 6 of the

incident light beam 5 reflected from the mirror 1 travels through the layer 13 towards the array of recesses 11 and undergoes total internal reflection at the surfaces 23 of the recesses since the refractive index of the material of the layer 13 is greater than the refractive index of the material in the recesses (which would typically be air). The light beam leaves the array of recesses 11 in a well known manner in the form of an interference pattern comprising a series of peaks at different angular positions relative to the axis 14, each peak comprising light of a particular wavelength or narrow band of wavelengths.

The optical transmission grating 2 would typically be formed of arrays of deep etched recesses 11 with reflecting surfaces 21, 22, 23 of width in the range of 5 - 20 microns. The distances (d_1 , d_2 , d_3) between the recesses 11 would typically be in the range of about 5 - 20 microns and the grating would typically have a length along each axis 14, 15 in the range of 500 microns to 2 millimetres. The faces 23 are typically at right angles to the axes 14, 15. The angle A between the axes 14, 15 is preferably a right angle so the beam portions 6, 7 travel parallel to each other between the mirror 1 and the grating 2.

The mirror 1 may also be formed in a layer of silicon by a deep etch extending all the way through the light guiding layer and would typically be from a few hundred microns to a few millimetres wide.

As indicated above, an advantage of the optical device illustrated in Figures 1, 2 and 3 is that it is compact because the light beam portions 6, 7 follow the same optical path in opposite directions and only one optical system, the mirror 1, is needed to collimate the incident beam 5 and direct it to the optical gratings 3, 4 and to direct the sets of individual beams emerging from the optical gratings to the receiving waveguides 8.

The optical system illustrated in Figures 1, 2 and 3 also preserves the phase distribution in the incident light beam 5 and therefore does not result in any loss of coherence.

Figure 6 illustrates an optical reflection grating constructed in a manner similar to that described above with reference to Figures 4 and 5 for an optical transmission grating. The reflection grating is formed from a linear array of generally triangular recesses 24 in a layer 25 of transparent material. Each recess 24 is formed with two surfaces 26, 27 extending generally at right angles to each other and connected by a third surface 28. The surfaces 28 of the array of recesses extend along an axis 29. The recesses 24 are spaced by distances d_1 , d_2 , d_3 etc. In the operation of the grating, a portion 30 of an incident light beam travels through the layer 25 towards the array of recesses and undergoes total internal reflection at the surfaces 28 since the refractive index of the material of the layer 25 is greater than the refractive index of the material in the recesses (which would typically be air). The incident light beam is therefore reflected away from the reflection grating and, as for a transmission grating, the reflected light beam leaves the recesses in a well known manner in the form of an interference pattern comprising a series of peaks at different angular positions relative to the axis 29, each peak comprising light of a particular wavelength or narrow band of wavelengths.

Figure 7 illustrates an optical device using an optical reflection grating comprising two parts 31, 32 arranged with their axes at right angles and two mirrors 33, 34 also arranged at right angles. An incident multi-wavelength light beam 35 is reflected off a first mirror 33 onto the first part 31 of the reflection grating. The beam is reflected off this first part 31 of the grating onto the second part 32 of the grating and from there onto a second mirror 34. The incident beam 35 is initially split up by reflection from the first part 31 of the grating into a set of individual light beams of different wavelengths or narrow bands of wavelengths and is further split up by reflection from the second part 32 of the grating. As in the two part transmission grating in the device illustrated in Figure 1, the resolution of the incident multi-wavelength light beam into individual single wavelength or narrow waveband light beams is improved by reflecting the incident beam of light from the two parts of the optical reflection gratings in succession.

Figure 7 shows the incident beam 35 being directed towards the first part 31 of the grating and being reflected therefrom to the second part 32 of the grating and

then to the mirror 34. In this case, the beam 35 is not split into two parts which are each directed to a respective part of the grating and then reflected to the other part of the grating. However, the arrangement may be modified to operate in this manner, e.g. by appropriate positioning of the mirrors, by the use of one or more semi-reflecting mirrors or by the use of other forms of optical system.

Figure 8 illustrates another optical device including an optical reflection grating comprising two parts 51, 52 and a lens 53. An incident multi-wavelength light beam 54 from an input waveguide 57 is collimated by passing through the lens 53 and is effectively divided into two beam portions 55, 56 by the positioning of the lens 53 relative to the grating parts 51, 52. Beam portion 55 is reflected and split up by the grating 51 and beam portion 56 is reflected and split up by the grating 52. The split up beam portion 55 is passed to and is further reflected and split up by grating 52 and the split up beam portion 56 is passed to and is further split up and reflected by grating 51. The split up beam portions then pass back to the lens 54 which focusses the individual light beam of different wavelengths or narrow bands of wavelengths to respective output waveguides 58. As in the two part transmission grating in the device illustrated in Figure 1, the resolution of the incident multi-wavelength light beam into individual single wavelength or narrow waveband light beams is improved by passing the incident beam of light through two optical grating parts in succession.

The input waveguide 57 and output waveguides 58 may be arranged in a manner similar to that shown and described above in relation to Figure 1. Conveniently, the input and output waveguides may comprise rib waveguides which lead to respective optical fibres (not shown), e.g. of an optical fibre ribbon. The waveguides lead to fibre coupling means (not shown) adapted to receive optical fibres to which the respective individual beams are to be transmitted.

The lens 53 may be provided in an integrated circuit in the form of an appropriately shaped deep-etched recess etched in the chip. Such integrated lenses are well known so will not be described further.

Figure 9 illustrates another optical device which, in this case, uses a chirped optical transmission grating comprising two parts 61, 62. An incident multi-wavelength light beam 63 from an input waveguide 66 is effectively divided into two beam portions 64, 65. Beam portion 64 is split up by and transmitted through the grating part 61 and beam portion 65 is split up by and transmitted through the grating part 62. The split up beam portion 64 is passed to and further split up by and transmitted through the grating part 62 and the split up part beam 65 is further split up by and transmitted through the grating part 61. Since the grating parts 61, 62 are chirped the split up beam portions on emergence from the grating parts are focussed so a lens such as that shown in Fig. 8 is not required.

The beam portions are thus split up into individual light beams of different wavelengths or narrow bands of wavelengths and these are focussed to respective output waveguides 67. As in the two part transmission grating in the device illustrated in Figure 1, the resolution of the incident multi-wavelength light beam into individual beams of light of different wavelengths or narrow wavelength bands is improved by passing the incident beam of light through two optical grating parts in succession.

The input and output waveguides 66 and 67 are similar to those shown in Figure 8. The waveguides 66, 67 may typically be spaced from each other by around 10 to 20 microns and may be connected to optical fibres (not shown) in an optical fibre ribbon (which are typically spaced from each other by about 250 microns) by forming the waveguides 66, 67 so they diverge from each other to an appropriate spacing which matches that of the optical fibres in the optical fibre ribbon.

Chirped optical transmission gratings as used in the device illustrated in Figure 9 are well known and are generally fabricated as illustrated in Figures 4 and 5 except that the spacing between adjacent recesses 11 varies, along the axes 14, 15 in a known manner to achieve the desired focussing effect.

A further advantage of the arrangement shown in Figure 9 is that, since the splitting up or dispersion of the part beams 64, 65 is shared between the two gratings 61, 62, the focussing provided by "chirping" of the gratings is also split into two, half being provided by each grating. This enables the angle of incidence

of the light beams on the faces 23 of the recesses 11, to be less than the critical angle, so that total internal reflection occurs and there is therefore little loss of light through the faces 23. With known arrangements using a chirped grating it is often difficult to arrange for the angle of incidence to be less than the critical angle so only part of the light is reflected from the grating and a large proportion of the light is lost by transmission through the grating.

As indicated above, as the arrangement shown in Figure 9 uses a chirped grating which both disperses light of different wavelengths and focusses the output light, it dispenses with the need to provide a mirror or other means to focus the different wavelengths to the respective receiving waveguides.

It will be appreciated that each of the embodiments described may use either a transmission grating or a reflection grating; the transmission grating shown in Figs. 1 - 3 and 9 may thus be replaced by a reflection grating and the reflection grating shown in Figs. 7 and 8 may be replaced by a transmission grating.

The optical system employed may take different forms and may comprise one or more mirrors, or semi-reflecting mirrors, mirrors of other forms, lenses, etc. depending on the required function of the device.

It will also be appreciated that the device may be used as a multiplexer, rather than as a de-multiplexer, by substituting light sources each of a single wavelength or narrow wavelength band for the light receivers 9 and substituting light receiving means for the multi-wavelength source referred to above. Operation of the device as a multiplexer is similar to its operation as a de-multiplexer by reversing the direction of light transmitted through the device.

Figure 10 is an enlarged view of part of an arrangement such as that shown in Figure 1 in which the geometry of the optical system and/or the mirror or grating is arranged so that the two portions of the beam are not re-combined. Instead, signals from a first portion of the beam, eg signals $\lambda_1, \lambda_2, \lambda_3, \lambda_4, \lambda_5$ and λ_6 are directed into waveguides 8 which lead to a first set of photodiodes 9 whereas signals $\lambda'_1, \lambda'_2, \lambda'_3, \lambda'_4, \lambda'_5$ and λ'_6 are directed into waveguides 8' which lead to a

second set of photodiodes 9'. One set of photodiodes may be used to provide output signals, whilst the other set may be used to monitor the outputs so feedback control can be provided to the SLD 10.

The optical device described herein may be used in apparatus such as that described in GB9727013.6 (publication no. GB2321130A) the disclosure of which is incorporated herein by reference.

As shown in Figure 11, the device may receive light from a broadband laser source, such as an SLD 10, having a high reflection (HR) coated back facet 10' and an anti-reflective (AR) coated front facet 10'' (to prevent a laser cavity being formed with the SLD), and the waveguides 8 lead to end facets 11 having semi-reflective coatings thereon. Laser cavities are thus formed between the HR coated facet 10' and the respective semi-reflective coated facets 11 and laser output is provided through the semi-reflective coated facets 11, each waveguide 8 providing a different wavelength. In this arrangement, the SLD 10 acts as a laser amplifier for all wavelengths and separate modulators (not shown) may be provided in each waveguide 8 to modulate the output signals.

Figure 12 shows a further embodiment in which the optical device is used as a multiplexer rather than a de-multiplexer. In this arrangement, a laser diode 12 is provided on each waveguide 8, each laser diode having a high reflection (HR) coated back facet 12' and an anti-reflective (AR) coated front facet 12'' (to prevent a laser cavity being formed with the laser diode), and waveguide 5 is used as an output waveguide and has an end facet 5' provided with a semi-reflective coating. Laser cavities are thus formed between the semi-reflective coated facet 5' and the respective HR coated facets 12' and the signal output through the semi-reflective facet 5' comprises a multiplexed signal of the outputs of the individual laser diodes 12. In this arrangement, each laser diode 12 acts as a gain element and modulates the respective wavelength it emits.

The laser diodes 12 may each be hybridised on the chip in the manner described in GB2307786A referred to above or they may be provided in the form of a laser bar, ie a series of laser diodes on a common strip hybridised on the chip.

In embodiments in which signals are transmitted to or received from optical fibres, these are preferably connected to waveguides integrated on the device by fibre coupling means such as those disclosed in WO-A-97/42534.

In the above arrangements, the device is thus integrated within a laser cavity or multiple cavities and used to multiplex or de-multiplex lasing wavelengths within the cavity or cavities. Such an arrangement may be used as a transceiver operating on multiple wavelengths or in other apparatus requiring wavelength division multiplexing or de-multiplexing of laser light.

CLAIMS

1. An optical device for splitting up a multi-wavelength light beam into a plurality of individual beams of light of different wavelengths or narrow bands of wavelengths comprising:

an optical grating, and

an optical system for directing an incident multi-wavelength light beam onto the grating so that a first portion of the light beam passes through the grating in one direction and is split into a first set of individual light beams of different wavelengths or narrow bands of wavelengths and a second portion of the light beam passes through the grating in the opposite direction and is split into a second set of individual light beams of different wavelengths or narrow bands of wavelengths.

2. An optical device for splitting up a multi-wavelength light beam into a plurality of individual beams of light of different wavelengths or narrow bands of wavelengths comprising

an optical grating having a first part and a second part, and

an optical system for directing an incident multi-wavelength light beam onto the grating so that the incident beam passes through the two parts of the grating in succession and the two parts of the grating act in succession on the incident light beam to split the incident light beam into a set of individual beams of light of different wavelengths or narrow bands of wavelengths.

3. An optical device as claimed in Claim 1 in which the optical grating has a first part and a second part, and

the optical system is arranged to direct a first portion of the incident beam onto the first part of the grating, and a second portion of the incident beam onto the second part of the grating,

the optical grating being constructed so that the first portion of the incident beam, on leaving the first part of the grating, is transmitted to the second part of the grating and the two parts of the grating split the first portion of the incident beam into a first set of individual beams of different wavelengths or narrow bands of wavelengths, and so that

the second portion of the incident beam, on leaving the second part of the grating, is transmitted to the first part of the grating and the two parts of the grating split the second portion of the incident beam into a second set of individual beams of different wavelengths or narrow bands of wavelengths.

4. An optical device as claimed in Claim 1 or 3 in which the first and second portions of the beams are re-combined by the optical system after passing through the optical grating.
5. An optical device as claimed in Claim 3 or 4 in which the two parts of the grating are co-planar and inclined to each other at an angle.
6. An optical device as claimed in Claim 5 in which the angle is a right angle .
7. An optical device as claimed in any one of the preceding claims including a further optical system for receiving the individual beams from the optical grating and directing the individual beams to respective optical receiving means.
8. An optical device as claimed in Claim 7 in which the optical system and the further optical system comprise a common mirror for directing an incident multi-wavelength light beam onto the grating and for receiving the

individual beams returning from the grating and for directing the individual beams to respective optical receiving means.

9. An optical device as claimed in Claim 7 or 8 in which the optical receiving means comprises a plurality of waveguides each positioned to receive a respective one of the individual beams.
10. An optical device as claimed in Claim 7, 8 or 9 which is incorporated within a laser cavity or multiple laser cavities.
11. An optical device as claimed in Claim 10 arranged to receive light from a multi-wavelength source and provide an output comprising a plurality of laser wavelengths.
12. An optical device as claimed in Claim 9 in which the waveguides lead to optical sensors, preferably photodiodes.
13. An optical device as claimed in Claim 9 in which the waveguides lead to fibre coupling means adapted to receive optical fibres to which the respective individual beams are to be transmitted.
14. An optical device as claimed in any one of the preceding claims in which the optical grating is a transmission grating.
15. An optical device as claimed in any one of Claims 1 to 13 in which the optical grating is a reflection grating.
16. An optical device as claimed in any one of the preceding claims in which the optical grating is a chirped grating.
17. An optical device as claimed in Claim 16 arranged such that a multi-wavelength light beam from an input waveguide or optical fibre diverges from the input waveguide or optical fibre and is incident upon the chirped grating and light returning from the grating is directed thereby to a series

of receiving waveguides or optical fibres each positioned to receive light of a given wavelength or narrow wavelength band from the grating.

18. An optical device as claimed in any one of the preceding claims integrated on a silicon chip, preferably a silicon-on-insulator chip.
19. An optical device as claimed in any preceding claim arranged for use as a multiplexer by reversing the direction of light beam(s) transmitted therethrough.
20. A multiplexer or de-multiplexer substantially as hereinbefore described with reference to the accompanying drawings.

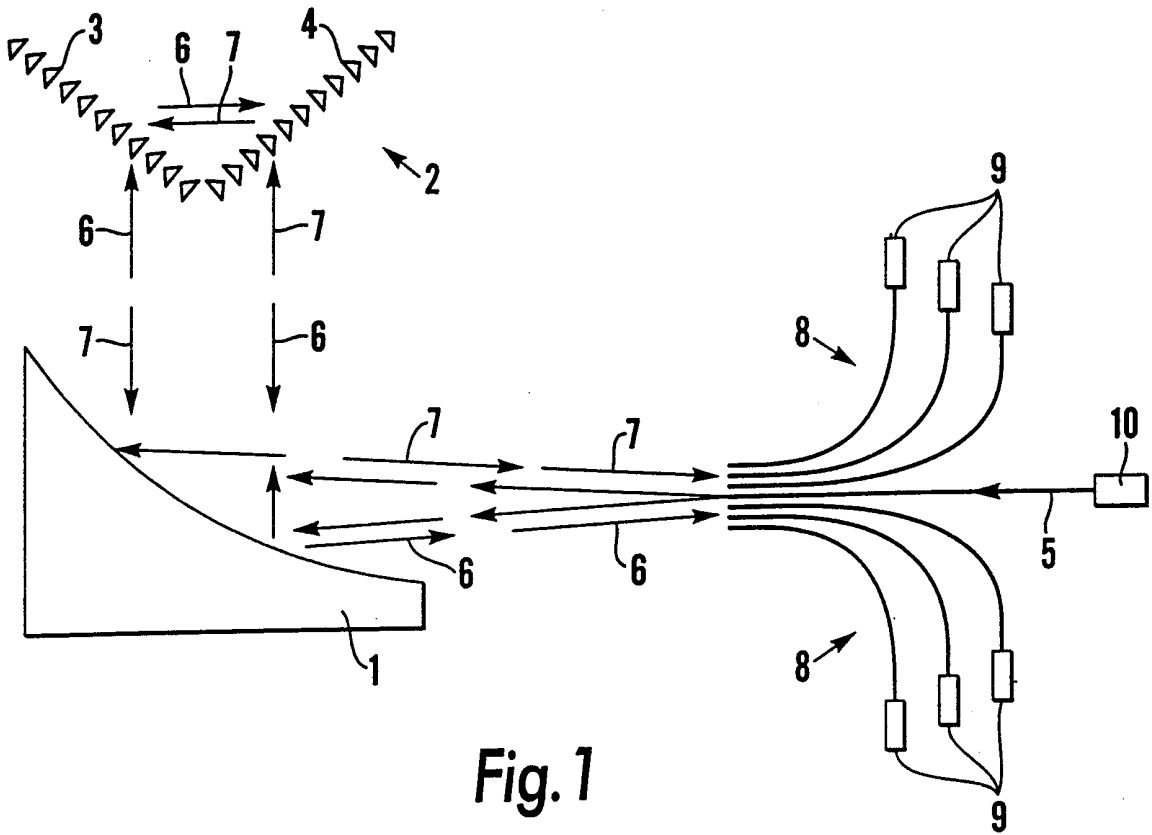

Fig. 1

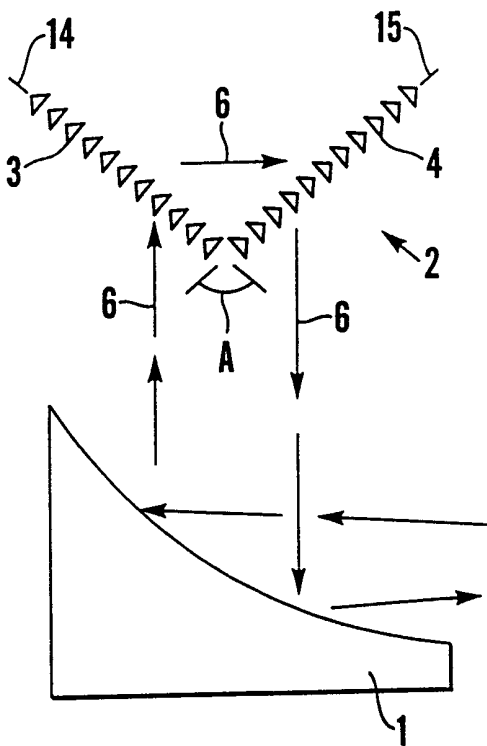

Fig. 2

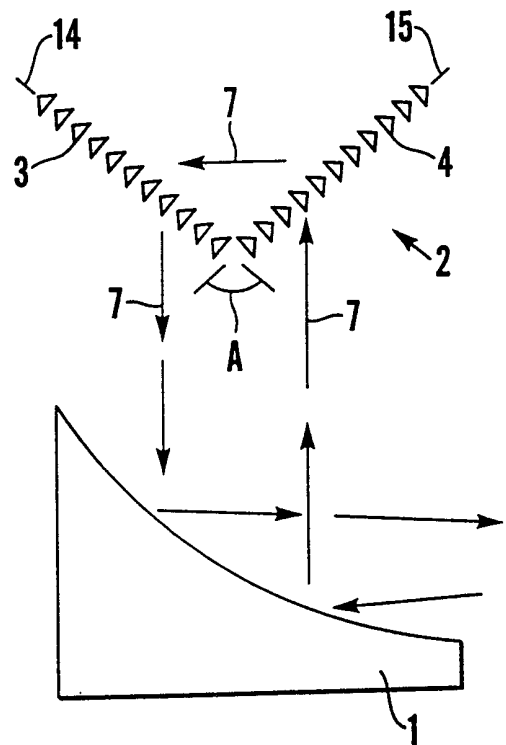

Fig. 3

2/5

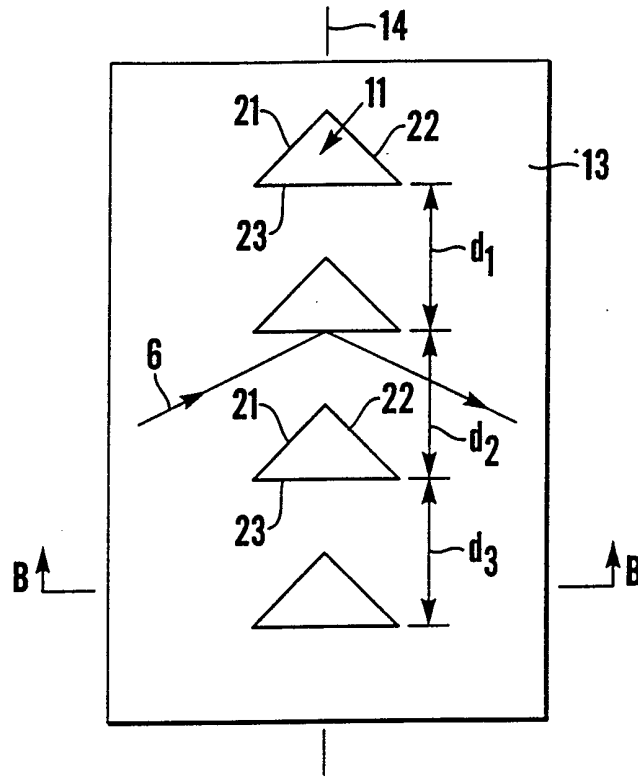

Fig. 4

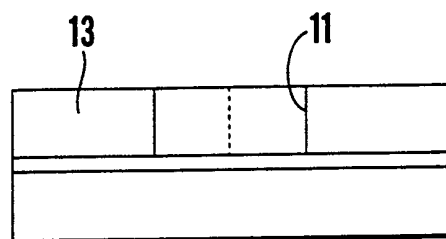

Fig. 5

3/5

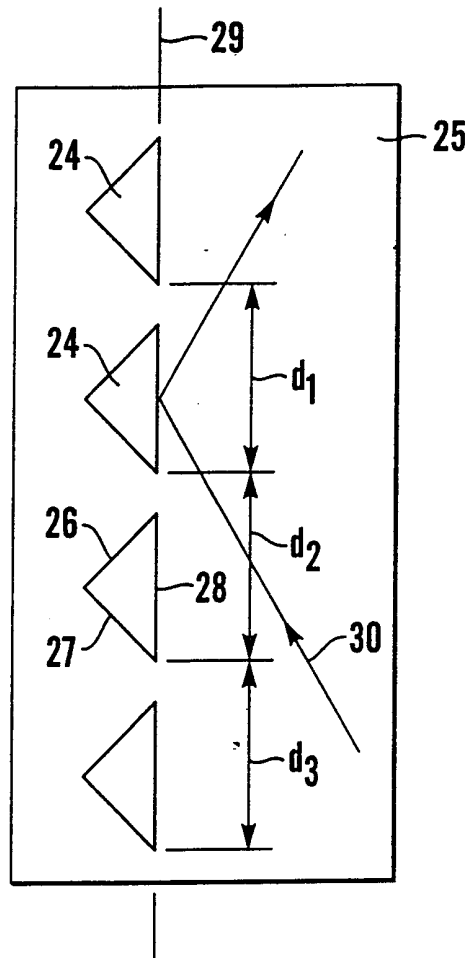

Fig. 6

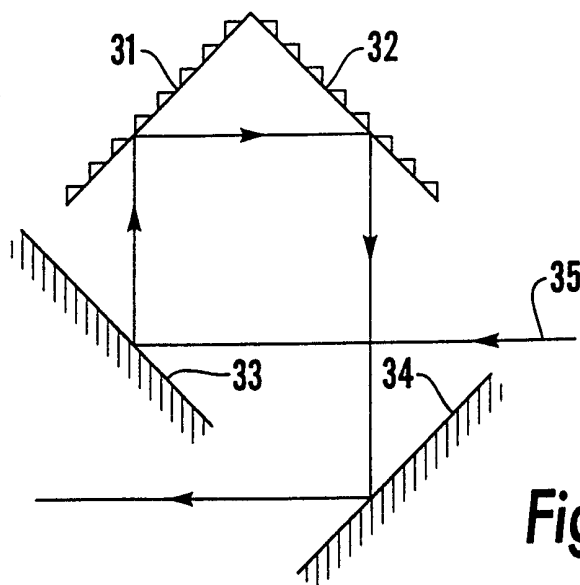

Fig. 7

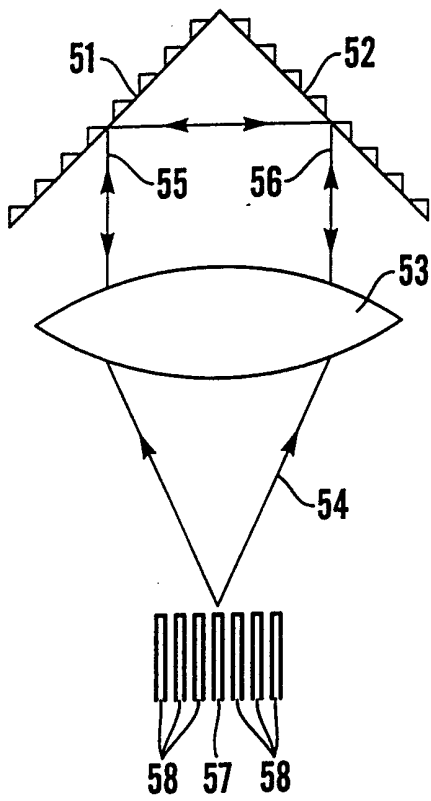

Fig. 8

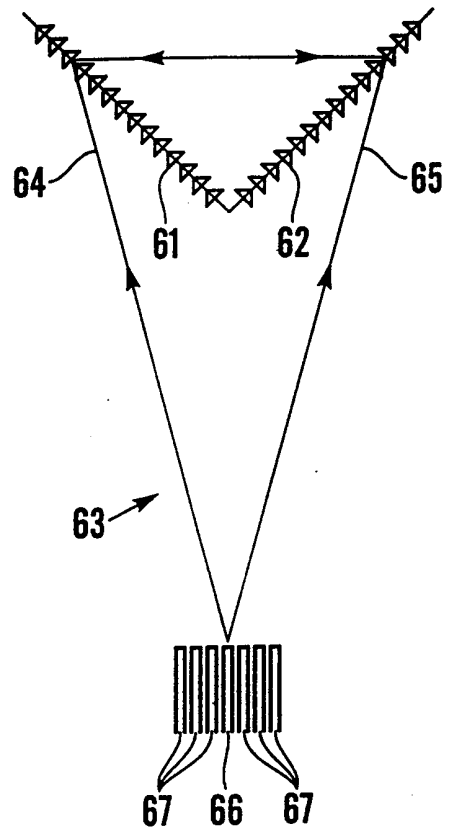

Fig. 9

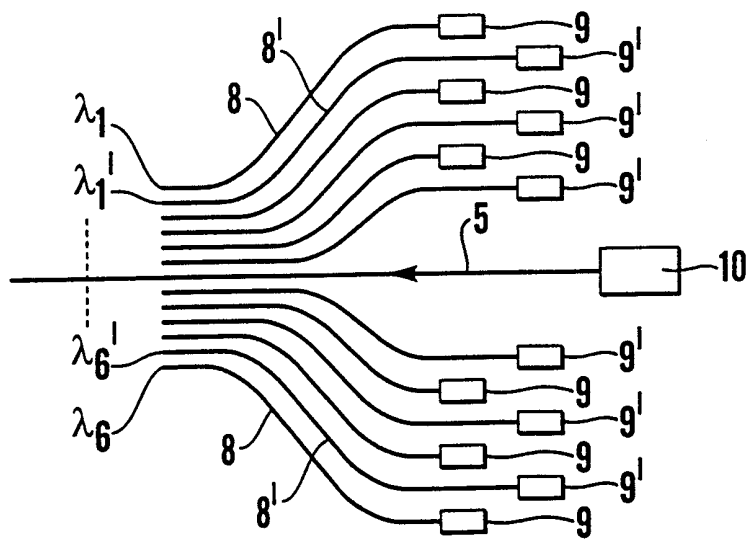

Fig. 10

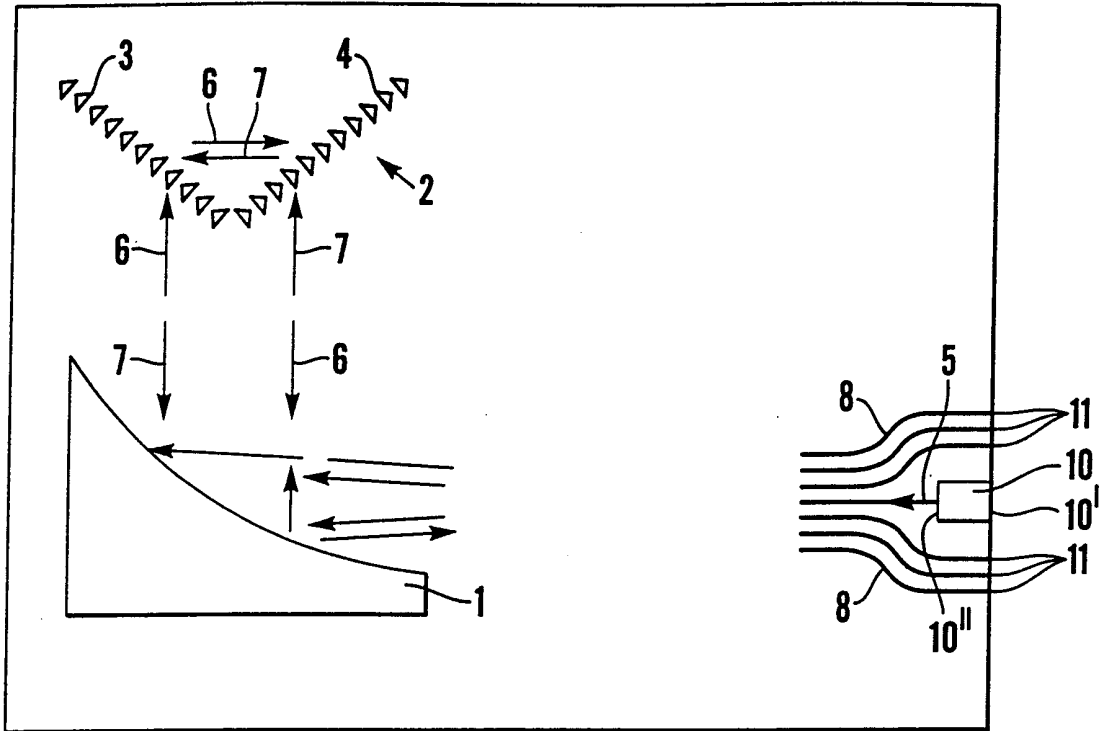

Fig. 11

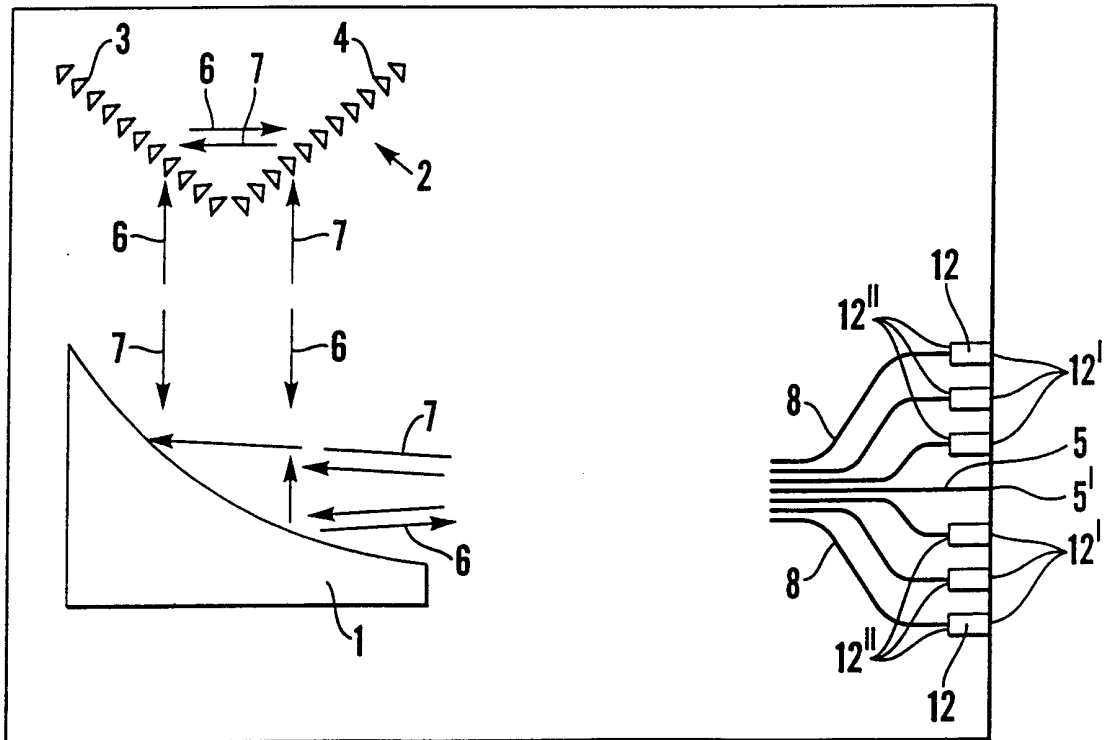

Fig. 12

INTERNATIONAL SEARCH REPORT

International Application No
PCT/GB 99/01288

A. CLASSIFICATION OF SUBJECT MATTER IPC 6 G02B6/122				
According to International Patent Classification (IPC) or to both national classification and IPC				
B. FIELDS SEARCHED				
Minimum documentation searched (classification system followed by classification symbols) IPC 6 G02B				
Documentation searched other than minimum documentation to the extent that such documents are included in the fields searched				
Electronic data base consulted during the international search (name of data base and, where practical, search terms used)				
C. DOCUMENTS CONSIDERED TO BE RELEVANT				
Category °	Citation of document, with indication, where appropriate, of the relevant passages	Relevant to claim No.		
A	US 5 450 512 A (ASAKURA HIROYUKI) 12 September 1995 (1995-09-12) abstract; figures 1,6 column 2, line 55 - column 3, line 3 ---	1,2		
A	EP 0 762 161 A (FRANCE TELECOM) 12 March 1997 (1997-03-12) abstract; figure 5 column 5, line 4 - column 6, line 34 --- -/--	1,2		
<input checked="" type="checkbox"/> Further documents are listed in the continuation of box C.				
<input checked="" type="checkbox"/> Patent family members are listed in annex.				
° Special categories of cited documents :				
<table style="width: 100%; border: none;"> <tr> <td style="width: 50%; border: none; vertical-align: top;"> "A" document defining the general state of the art which is not considered to be of particular relevance "E" earlier document but published on or after the international filing date "L" document which may throw doubts on priority claim(s) or which is cited to establish the publication date of another citation or other special reason (as specified) "O" document referring to an oral disclosure, use, exhibition or other means "P" document published prior to the international filing date but later than the priority date claimed </td> <td style="width: 50%; border: none; vertical-align: top;"> "T" later document published after the international filing date or priority date and not in conflict with the application but cited to understand the principle or theory underlying the invention "X" document of particular relevance; the claimed invention cannot be considered novel or cannot be considered to involve an inventive step when the document is taken alone "Y" document of particular relevance; the claimed invention cannot be considered to involve an inventive step when the document is combined with one or more other such documents, such combination being obvious to a person skilled in the art. "&" document member of the same patent family </td> </tr> </table>			"A" document defining the general state of the art which is not considered to be of particular relevance "E" earlier document but published on or after the international filing date "L" document which may throw doubts on priority claim(s) or which is cited to establish the publication date of another citation or other special reason (as specified) "O" document referring to an oral disclosure, use, exhibition or other means "P" document published prior to the international filing date but later than the priority date claimed	"T" later document published after the international filing date or priority date and not in conflict with the application but cited to understand the principle or theory underlying the invention "X" document of particular relevance; the claimed invention cannot be considered novel or cannot be considered to involve an inventive step when the document is taken alone "Y" document of particular relevance; the claimed invention cannot be considered to involve an inventive step when the document is combined with one or more other such documents, such combination being obvious to a person skilled in the art. "&" document member of the same patent family
"A" document defining the general state of the art which is not considered to be of particular relevance "E" earlier document but published on or after the international filing date "L" document which may throw doubts on priority claim(s) or which is cited to establish the publication date of another citation or other special reason (as specified) "O" document referring to an oral disclosure, use, exhibition or other means "P" document published prior to the international filing date but later than the priority date claimed	"T" later document published after the international filing date or priority date and not in conflict with the application but cited to understand the principle or theory underlying the invention "X" document of particular relevance; the claimed invention cannot be considered novel or cannot be considered to involve an inventive step when the document is taken alone "Y" document of particular relevance; the claimed invention cannot be considered to involve an inventive step when the document is combined with one or more other such documents, such combination being obvious to a person skilled in the art. "&" document member of the same patent family			
Date of the actual completion of the international search		Date of mailing of the international search report		
4 August 1999		11/08/1999		
Name and mailing address of the ISA		Authorized officer		
European Patent Office, P.B. 5818 Patentlaan 2 NL - 2280 HV Rijswijk Tel. (+31-70) 340-2040, Tx. 31 651 epo nl, Fax: (+31-70) 340-3016		Jakober, F		

INTERNATIONAL SEARCH REPORT

International Application No
PCT/GB 99/01288

C.(Continuation) DOCUMENTS CONSIDERED TO BE RELEVANT		
Category °	Citation of document, with indication, where appropriate, of the relevant passages	Relevant to claim No.
A	OJHA S M ET AL: "ETCHING OF LOW LOSS MIRRORS FOR PHOTONIC IC'S" PROCEEDINGS OF THE INTERNATIONAL CONFERENCE ON INDIUM PHOSPHIDE AND RELATED MATERIALS, PARIS, APR. 19 - 22, 1993, no. CONF. 5, 19 April 1993 (1993-04-19), pages 524-528, XP000462825 INSTITUTE OF ELECTRICAL AND ELECTRONICS ENGINEERS the whole document ----	1,2
A	EP 0 074 143 A (PHILIPS NV) 16 March 1983 (1983-03-16) abstract; figure 2 page 3, line 27 - page 4, line 21 ----	1,2
A	EP 0 555 778 A (MATSUSHITA ELECTRIC IND CO LTD) 18 August 1993 (1993-08-18) abstract; figure 1 column 3, line 24 - column 4, line 6 -----	1,2

INTERNATIONAL SEARCH REPORT

Information on patent family members

International Application No PCT/GB 99/01288

Patent document cited in search report	A	Publication date	Patent family member(s)	Publication date
US 5450512	A	12-09-1995	JP 6300937 A	28-10-1994
EP 0762161	A	12-03-1997	FR 2738432 A US 5748815 A	07-03-1997 05-05-1998
EP 0074143	A	16-03-1983	NL 8104123 A AU 550888 B AU 8798582 A CA 1241560 A DK 394482 A JP 1724208 C JP 3022961 B JP 58082220 A US 4741588 A	05-04-1983 10-04-1986 17-03-1983 06-09-1988 08-03-1983 24-12-1992 28-03-1991 17-05-1983 03-05-1988
EP 0555778	A	18-08-1993	JP 5224158 A DE 69313157 D DE 69313157 T US 5311606 A	03-09-1993 25-09-1997 19-03-1998 10-05-1994