

(19) World Intellectual Property Organization  
International Bureau



(43) International Publication Date  
12 September 2003 (12.09.2003)

PCT

(10) International Publication Number  
WO 03/073970 A1

- (51) International Patent Classification<sup>7</sup>: A61F 13/00
- (21) International Application Number: PCT/US02/41300
- (22) International Filing Date:  
20 December 2002 (20.12.2002)
- (25) Filing Language: English
- (26) Publication Language: English
- (30) Priority Data:  
60/360,405 28 February 2002 (28.02.2002) US
- (71) Applicant (for all designated States except US):  
HILL-ROM SERVICES, INC. [US/US]; 1069 State  
Route 46 East, Batesville, IN 47006-9167 (US).
- (72) Inventors; and
- (75) Inventors/Applicants (for US only): LOCKWOOD, Jeffrey, S. [US/US]; 500 North Walnut, Batesville, IN 47006 (US). PETROSENKO, Robert [CA/US]; 30 Belmont Place West, Batesville, IN 47006 (US).
- (74) Agent: CONARD, Richard, D.; Barnes & Thornburg, 11 South Meridian Street, Indianapolis, IN 46204 (US).
- (81) Designated States (national): AE, AG, AL, AM, AT, AU, AZ, BA, BB, BG, BR, BY, BZ, CA, CH, CN, CO, CR, CU, CZ, DE, DK, DM, DZ, EC, EE, ES, FI, GB, GD, GE, GH, GM, HR, HU, ID, IL, IN, IS, JP, KE, KG, KP, KR, KZ, LC, LK, LR, LS, LT, LU, LV, MA, MD, MG, MK, MN, MW, MX, MZ, NO, NZ, OM, PH, PL, PT, RO, RU, SC, SD, SE, SG, SK, SL, TJ, TM, TN, TR, TT, TZ, UA, UG, US, UZ, VC, VN, YU, ZA, ZM, ZW.

[Continued on next page]

(54) Title: EXTERNAL CATHETER ACCESS TO VACUUM BANDAGE

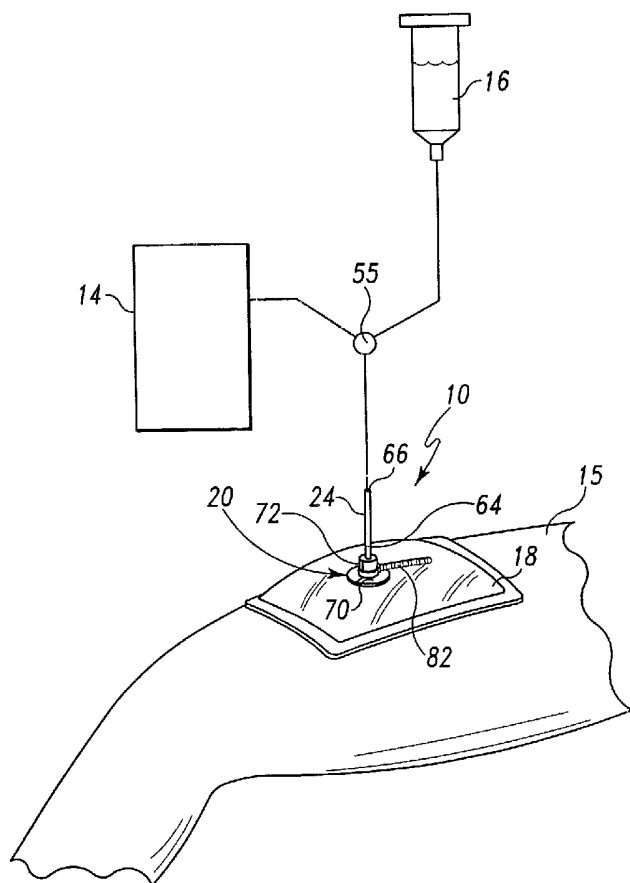

(57) Abstract: A bandage (10) is provided for use with a wound (12) having a wound surface (13). The bandage (10) is connectable to a vacuum source (14) and may include a flexible cover (18) positioned over the wound (12) and a collar coupled to the cover (18). The cover (18) includes a port (92) and is configured to seal to a patient's healthy skin (15) surrounding the wound (12). The collar (20, 120) maybe coupled to the cover (18) and include a passageway (22) in communication with the port (92) of the cover (18). The passageway (22) is configured to receive at least a portion of a tube (24) in communication with the vacuum source (14). The bandage (10) may also include a sealer (82, 96) coupled to the collar (20, 120). The sealer (82, 96) may be configured to provide a substantially airtight seal between the tube (24) and the passageway (22) to create a sealed environment capable of maintaining a negative pressure between the cover (18) and the wound surface (13).



WO 03/073970 A1



**(84) Designated States (regional):** ARIPO patent (GH, GM, KE, LS, MW, MZ, SD, SL, SZ, TZ, UG, ZM, ZW), Eurasian patent (AM, AZ, BY, KG, KZ, MD, RU, TJ, TM), European patent (AT, BE, BG, CH, CY, CZ, DE, DK, EE, ES, FI, FR, GB, GR, IE, IT, LU, MC, NL, PT, SE, SI, SK, TR), OAPI patent (BF, BJ, CF, CG, CI, CM, GA, GN, GQ, GW, ML, MR, NE, SN, TD, TG).

**Declarations under Rule 4.17:**

— *as to applicant's entitlement to apply for and be granted a patent (Rule 4.17(ii)) for the following designations AE, AG, AL, AM, AT, AU, AZ, BA, BB, BG, BR, BY, BZ, CA, CH, CN, CO, CR, CU, CZ, DE, DK, DM, DZ, EC, EE, ES, FI, GB, GD, GE, GH, GM, HR, HU, ID, IL, IN, IS, JP, KE, KG, KP, KR, KZ, LC, LK, LR, LS, LT, LU, LV, MA, MD, MG, MK, MN, MW, MX, MZ, NO, NZ, OM, PH, PL, PT, RO, RU, SC, SD, SE, SG, SK, SL, TJ, TM, TN, TR, TT, TZ, UA, UG, UZ, VC, VN, YU, ZA, ZM, ZW, ARIPO patent (GH, GM, KE, LS, MW, MZ, SD, SL, SZ, TZ, UG, ZM, ZW), Eurasian patent (AM, AZ, BY, KG, KZ, MD, RU, TJ, TM), European patent (AT, BE, BG, CH, CY, CZ, DE, DK, EE, ES, FI, FR, GB, GR, IE, IT, LU, MC, NL, PT, SE, SI, SK, TR), OAPI patent (BF, BJ, CF, CG, CI, CM, GA, GN, GQ, GW, ML, MR, NE, SN, TD, TG)*

— *as to the applicant's entitlement to claim the priority of the earlier application (Rule 4.17(iii)) for the following designations AE, AG, AL, AM, AT, AU, AZ, BA, BB, BG, BR, BY, BZ, CA, CH, CN, CO, CR, CU, CZ, DE, DK, DM, DZ, EC, EE, ES, FI, GB, GD, GE, GH, GM, HR, HU, ID, IL, IN, IS, JP, KE, KG, KP, KR, KZ, LC, LK, LR, LS, LT, LU, LV, MA, MD, MG, MK, MN, MW, MX, MZ, NO, NZ, OM, PH, PL, PT, RO, RU, SC, SD, SE, SG, SK, SL, TJ, TM, TN, TR, TT, TZ, UA, UG, UZ, VC, VN, YU, ZA, ZM, ZW, ARIPO patent (GH, GM, KE, LS, MW, MZ, SD, SL, SZ, TZ, UG, ZM, ZW), Eurasian patent (AM, AZ, BY, KG, KZ, MD, RU, TJ, TM), European patent (AT, BE, BG, CH, CY, CZ, DE, DK, EE, ES, FI, FR, GB, GR, IE, IT, LU, MC, NL, PT, SE, SI, SK, TR), OAPI patent (BF, BJ, CF, CG, CI, CM, GA, GN, GQ, GW, ML, MR, NE, SN, TD, TG)*

**Published:**

— *with international search report*  
 — *before the expiration of the time limit for amending the claims and to be republished in the event of receipt of amendments*

*For two-letter codes and other abbreviations, refer to the "Guidance Notes on Codes and Abbreviations" appearing at the beginning of each regular issue of the PCT Gazette.*

## EXTERNAL CATHETER ACCESS TO VACUUM BANDAGE

## BACKGROUND OF THE INVENTION

5 The present disclosure relates to bandages for wounds, and more particularly to the provision of bandages for use with a vacuum and/or irrigation source. Specifically, the present disclosure relates to external catheter access to a wound through the bandage.

10 The prior art contemplates that chronic wounds may be treated by providing a vacuum in the space above the wound to promote healing. A number of prior art references teach the value of the vacuum bandage or the provision of vacuum in the space above the surface of a chronic wound.

15 A vacuum bandage is a bandage having a cover for sealing about the outer perimeter of the wound and under which a vacuum is established to act on the wound surface. Applying vacuum to the wound surface promotes healing of chronic wounds. Typically, suction tubes are provided for drawing exudate away from the wound and for creating vacuum under the cover. If the cover is a flexible cover, which is typically more comfortable for the patient, a packing may be provided under the cover to fill the space in which the vacuum is formed. It will be appreciated, however, that the packing will be omitted by many caregivers, and it may be  
20 preferable not to have packing.

The following U.S. Patents establish the nature of vacuum treatment bandages and devices: 6,095,992, 6,080,189, 6,071,304, 5,645,081, 5,636,643, 5,358,494, 5,298,015, 4,969,880, 4,655,754, 4,569,674, 4,382,441, and 4,112,947. All of such references are incorporated herein by reference for purposes of disclosing  
25 the nature of such vacuum treatment of wounds.

As shown, for example, in U.S. Patent No. 5,645,081 (hereinafter the '081 patent), a method of treating tissue damage is provided by applying negative pressure to a wound. The negative pressure is provided in sufficient duration and magnitude to promote tissue migration in order to facilitate the closure of the wound.  
30 Fig. 1 of the '081 patent discloses an open cell polyester foam section covering the wound, a flexible hollow tube inserted into the foam section at one end and attached to a vacuum pump at another end, an adhesive sheet overlying the foam section, and tubing to adhere to the skin surrounding the wound in order to form a seal that allows

-2-

the creation of a vacuum when the suction pump is operating. The '081 patent further teaches use of negative pressure between about 0.1 and 0.99 atmospheres and that the pressure can be substantially continuous and is relieved only to change the dressing on the wound. Alternatively, the '081 patent teaches use of a cyclic application of pressure in alternating periods of application and non-application. In a preferred embodiment, pressure is applied in five-minute periods of application and non-application.

Various other prior art references teach the value of the vacuum bandage or the provision of vacuum to the surface of a chronic wound. Several Russian language articles exist which establish the efficacy of vacuum therapy in the 1980's. Examples of such prior art articles, each of which discusses the use of application of vacuum to a wound to promote healing, are as follows: "Vacuum therapy in the treatment of acute suppurative diseases of soft tissues and suppurative wounds", Davydov, et al., Vestn, Khir., Sept. 1988 (The Sept. 1988 article); "Pathenogenic mechanism of the effect of vacuum therapy on the course of the wound process", Davydov, et al. Khirurgiia, June 1990 (the June 1990 article); and "Vacuum therapy in the treatment of suppurative lactation mastitis", Davydov, et al. Vestn. Khir., Nov. 1986 (the Nov. 1986 article).

The Russian articles distinguish wound drainage from use of vacuum therapy for healing. The Russian authors report that vacuum therapy resulted in faster cleansing of the wound and more rapid detoxification than with the traditional incision-drainage method. The November 1986 Russian article describes the vacuum therapy techniques as a reduction of 0.8-1 atmosphere for 20 minutes at the time of surgery, and subsequent 1.5 to 3 hour treatments at a reduced pressure of 0.1 to 0.15 from atmosphere, twice daily. These Russian articles teach the use of negative pressure to effect healing. The articles describe using several sessions per day, each lasting up to one hour, with a vacuum of 76-114 mmHg. The Russian articles teach using this vacuum method to decrease the number of microbes in the wound. The June 1990 Russian article teaches that this vacuum therapy provides a significant antibacterial effect. The article describes the stepped up inflow of blood to the zone around the wound to lead to an increase in the number of leukocytes reaching the focus of inflammation. Subsequent articles and patents further develop the benefits obtained with vacuum therapy.

-3-

Retention discs for use with tubing are known as well. For example, Cook Urological Inc. manufactures a silicone retention disc used to stabilize indwelling catheters such as the Khonsari disc having order number VPI-052019, for example. These discs are supplied by Cook in sterile peel-open packages. Such retention discs are available in a variety of sizes to fit catheters having different outer diameters, for example.

Often, these external retention discs are used to prevent indwelling catheters from migrating inward after they have been implanted. Other devices are known in the art to prevent inward tube migration. See, for example, U.S. Pats. Nos. 5,374,254 and 5,484,420 which generally disclose retention bolsters for supporting catheters.

#### SUMMARY OF THE INVENTION

The present invention comprises one or more of the following features or combinations thereof:

A bandage connectable to a vacuum source or an irrigation source is provided for use with a wound having a wound surface. The bandage illustratively includes a flexible cover positioned over the wound and configured to seal with a patient's healthy skin surrounding the wound. The cover may include a port. The bandage may include a collar coupled to the cover, the collar including a passageway in communication with the port of the cover. The passageway may be configured to receive at least a portion of a tube in communication with the vacuum source or irrigation source. The bandage may further include a sealer coupled to the collar and configured to create an airtight seal between the tube and the passageway to create a sealed environment below the cover and above the wound surface.

The collar may include a disc and a tube receiver coupled to the disc. The tube receiver may include the passageway configured to receive a portion of the tube in communication with either the vacuum source or the irrigation source. The collar may be coupled to a top surface of the cover.

In illustrative embodiments, the collar may include a slit through the tube receiver and the disc portion extending from the passageway to an outer edge of the disc portion. This slit may be defined by a first end and a second end of the collar. The first and second ends normally engage each other so that the collar is in a closed

-4-

position. The first and second ends move to an opened position spaced apart from each other when the tube is received in part within the passageway of the tube receiver.

5 In further embodiments, the sealer may be a pull-tab positioned around a neck portion of the tube receiver. The pull-tab tightens around the neck portion to move the collar from the opened position to the closed position to create a substantially airtight seal between the tube and the collar.

10 In another embodiment, the sealer may be a thin, elastic membrane covering the passageway of the collar. In use, the tube breaks the membrane when inserted into the passageway. The broken membrane creates a seal between the collar and the tube.

15 Other features of the invention will become apparent to those skilled in the art upon consideration of the following detailed description of the preferred embodiments exemplifying the best mode of carrying out the invention as presently perceived.

#### BRIEF DESCRIPTION OF THE DRAWINGS

The detailed description particularly refers to the accompanying figures in which:

20 Fig. 1 is a part perspective, part diagrammatic view of a wound care bandage showing the wound care bandage located on the leg of a patient and coupled to both a vacuum source and an irrigation source through the use of a switch valve and further showing a collar positioned on top of the bandage;

25 Fig. 2 is an exploded perspective view of the wound care bandage positioned above a wound bed showing a wound contacting layer and a cover of the bandage which cooperate to form a wound dressing member for placement within the wound bed, showing a sealing film or outer cover to cover the member and seal about the wound, and also showing the collar coupled to the outer cover to receive a portion of a vacuum/irrigation tube in communication with the vacuum source or the  
30 irrigation source;

Fig. 3 is a sectional view of a bandage positioned within the wound bed and showing the film or outer cover of the bandage coupled to the healthy skin surrounding the bandage to create a sealed vacuum space above the wound and

-5-

showing a portion of the vacuum/irrigation tube received in the collar and the outer cover and coupled to the member;

Fig. 4 is a perspective view with portions broken away showing the collar coupled to the outer cover, a portion of the tube received in the collar and the outer cover, a slit of the collar extending from an aperture of the collar to an outer edge or rim of the collar, and a pull-tab arranged for placement around a neck of the collar to tighten the collar about the tube;

Fig. 5 is a perspective view similar to Fig. 4 showing the pull-tab around the neck of the collar and pulled tight around the neck to close the slit of the collar to create a substantially airtight seal between the collar and the tube;

Fig. 6 is a perspective view of an alternative collar of the wound care bandage of the present disclosure showing the alternative collar formed without the slit shown in the previous embodiment and including a thin, elastic membrane across the opening or aperture of the collar;

Fig. 7 is a sectional view of the alternative collar of Fig. 6 showing the vacuum/irrigation tube being pushed through the membrane to break the membrane while a portion of the tube is inserted through the collar; and

Fig. 8 is a sectional view similar to Fig. 7 showing a portion of the tube extending through the collar and showing the broken membrane forming a substantially airtight seal between the tube and the collar.

#### DETAILED DESCRIPTION OF THE DRAWINGS

A vacuum bandage 10 is provided for use with a wound 12 having a wound surface 13, as shown in Fig. 2. Vacuum bandage 10 is provided for use with a vacuum source 14 and an irrigation source 16, through the use of a switch valve 55, as shown, for example, in Fig. 1. Bandage 10 promotes the healing of wound 12 by providing vacuum therapy to the wound 12 to promote blood flow and remove exudate from wound surface 13 of the wound 12 and by providing for irrigation of the wound 12 with fluids such as saline, for example. Reference is made to U.S. Patent No. 6,458,109 which discloses similar vacuum and irrigation treatment for wounds. This application is incorporated herein by reference. An illustrative vacuum and irrigation system is disclosed in U.S. Patent Publication No. US 2002/0161317 A1. Additionally, an illustrative vacuum bandage is disclosed in U.S. Patent Publication

-6-

No. US 2002/0065494 A1. Each of these two applications is specifically incorporated herein by reference.

As shown in Fig. 1, bandage 10 includes a sealing film or outer cover 18 positioned above the wound 12 to seal to a patient's healthy skin 15 surrounding the wound 12 to create a sealed environment between the wound surface 13 and the outer cover 18 in which negative pressure or vacuum can be established. Bandage 10 further includes a collar 20 coupled to a top surface 19 of outer cover 18, as shown in Figs. 1-5. Collar 20 includes a passageway 22 for receiving a portion of a vacuum/irrigation tube 24 in communication with the vacuum source 14 and/or the irrigation source 16. Collar 20 provides external catheter or tube access directly to wound surface 13 to provide wound surface 13 with irrigation and/or suction while maintaining an airtight environment around wound 12. Collar 20 is discussed in more detail below.

Looking now to Fig. 2, bandage 10 further includes a thin, flexible wound dressing member 30. Member 30 includes a wound contacting layer 32, a cover 34 coupled to the layer 32, and a connector 36 coupled to cover 34 for communication with tube 24, as shown in Fig. 3. Member 30 is placed on wound 12 adjacent wound surface 13, as shown in Fig. 3. Outer cover 18 is placed over member 30 to cover the entire wound 12 and to extend across and attach to the patient's healthy skin 15, as described above.

Layer 32, cover 34, and connector 36 of member 30 are each made of a medical grade silicone or other type of pliable elastomer. Two companies, for example, which manufacture such medical grade silicone are GE Silicones and NuSil Technology. It is within the scope of this disclosure, however, to include a member made of any type of thin, flexible material that is non-porous and non-foam-like. This thin, flexible material is also generally non-absorptive. For example, materials such as polyvinylchloride (PVC), PVC free of diethylhexyl phthalate (DEHP-free PVC), polyurethane, or polyethylene may be used in the manufacture of member 30. Further, layer 32, cover 34, and connector 36 may each be molded to include anti-microbial constituents. For example, it is within the scope of this disclosure to impregnate member 30 with silver ions which are known anti-microbials.

Member 30, including layer 32, cover 34, and connector 36, is also made of a generally non-adhesive material. Therefore, wound contacting layer 32,



-7-

which lies adjacent to the wound surface 13, does not adhere to the wound surface 13. Further, member 30 is solid in nature and generally non-compressible. Member 30 is also transparent. Therefore, a caregiver or user is able to see the wound 12 through member 30 when member 30 is placed adjacent to wound surface 13. This  
5 transparency allows the caregiver to view the progress of the healing of the wound 12.

Layer 32 includes a wound-contacting surface 38 and an upper or opposite surface 40. Wound contacting surface 38, or portions thereof, contact and conform to the wound surface 13. Opposite surface 40 includes a central area 42 and a plurality of channels 44 spaced-apart from and extending radially away from central  
10 area 42. As shown in Fig. 2, opposite surface 40 further includes concentric channels 46. Illustratively, each channel 44, 46 is 0.030 inch (0.762 mm) wide and 0.030 inch (0.762 mm) deep. It is within the scope of this disclosure, however, to include channels 44, 46 of opposite surface 40 having various widths and depths suitable for the present application. Central area 42 of layer 32 is provided to communicate with  
15 the vacuum source 14 and irrigation source 16 through a port 48 of cover 34, as is described below.

A plurality of radially extending protrusions or bosses 50 are positioned around central area 42. Bosses 50 are positioned between central area 42 and channels 44, 46, as shown in Fig. 2. Bosses 50 are provided to prevent central  
20 area 42 from collapsing in on port 48 of cover 34 to form a seal and effectively block fluid flow through port 48 while suction is applied to bandage 10. Port 48, as shown in Figs. 2 and 3, communicates with the vacuum source 14 and/or the irrigation source 16 via connector 23, collar 20, and tube 24. It is within the scope of this disclosure for tube 24 to be coupled to connector 36 by a barbed tube coupler (not  
25 shown) or to be coupled directly to connector 36.

As mentioned above, port 48 is in communication with central area 42 of layer 32. Illustratively, four bosses 50 are shown in Fig. 2. However, it is within the scope of this disclosure to provide any number of bosses 50 or the like around central area 42 of layer 32 to prevent central area 42 from sealing off port 48 of cover  
30 34 as suction is applied to bandage 10. Further, it is within the scope of this disclosure to include a boss or bosses having any shape in order to prevent central area 42 from sealing off port 48 when vacuum source 14 is running.

-8-

Connector 36, as shown in Figs. 2 and 3, is a tubal port coupled to a top surface 52 of cover 34. As mentioned above, it is within the scope of this disclosure for connector 36 to be a separate component of member 30 which is coupled to cover 34 or for connector 36 to be coupled to cover 34 by being molded integrally with cover 34. Connector 36 includes a vertical passageway 54 that communicates with port 48 of cover 34. Connector 36 connects with tube 24 to provide a vertical tube attachment for tube 24. Cover 34 includes a bottom surface 56 and top surface 52, as shown in Fig. 2, for example. Bottom surface 56 engages opposite surface 40 of layer 32, also shown in Fig. 2.

10 In some embodiments, member 30 is formed by heat sealing opposite surface 40 of layer 32 and bottom surface 56 of cover 34 together and by heat sealing connector 36 to top surface 52 of cover 34. For example, each of layer 32, cover 34, and connector 36 may be pre-shaped and formed from semi-cured silicone. Once the connector 36, cover 34, and layer 32 are placed together appropriately, the entire member 30 may be heated to heat seal and cure each of the three components to one another. Alternatively, for example, the cover 34 only may be made from semi-cured silicone while the layer 32 and connector 36 may be made from fully cured silicone, or visa versa. Once placed together and heated, connector 36 and layer 32 will heat seal to cover 34. Semi-cured silicon may be bought and pre-molded from a manufacturer such as NuSil Technology, for example.

20 Although the method of heat sealing the connector 36, cover 34, and layer 32 to each other is disclosed, it is within the scope of this disclosure to form member 30 by coupling layer 32, cover 34, and connector 36 together by any other means such as through the use of adhesives, for example. Further, it is within the scope of this disclosure to provide a member 30 where the cover 34 lies adjacent to, but is not coupled to, the layer 32.

As mentioned above, cover 34 is coupled to layer 32 and connector 36 is coupled to cover 34. Cover 34 and layer 32 cooperate to form distinct passageways 50 of member 30 defined by channels 44, 46 of layer 32 and bottom surface 56 of cover 34. Passageways 60 extend from the outer edges of member 30 and are in communication with central area 42 of layer 32. Central area 42 of layer 32 is in communication with port 48 of cover 34 which is in communication with the vacuum and/or irrigation sources 14, 16, via tube 24 extending through collar 20. Therefore,

passageways 60 are in communication with the vacuum and/or irrigation sources 14, 16.

Layer 32 further includes through holes 62 which extend from channels 44, 46 to wound contacting surface 38, as shown in Fig. 2. Holes 62 are distinct and are provided to communicate with channels 44, 46 of layer 32. Holes 62 therefore communicate with passageways 60 of member 30 and the vacuum and/or irrigation sources 14, 16 as well to allow the suction from the vacuum source 14 and/or the fluid from the irrigation source 16 to reach the wound bed surface 13 via the holes 60. Illustratively, holes 62 are 0.020 inch (0.508 mm) in diameter and are spaced approximately 0.500 inch (12, 700 mm) apart along channels 44, 46 of layer 32. It is, however, within the scope of the disclosure to include holes having other suitable sized diameters and/or other suitable spacing that allow for the removal of exudate without generally clogging.

As mentioned above, bandage 10 further includes sealing film or outer cover 18. Outer cover 18 covers the entire wound 12 by extending over wound 12 and attaching to the patient's healthy skin 15 surrounding wound 12. Preferably, film or outer cover 18 is an occlusive or semi-occlusive material which allows water vapor to permeate though. Because of this characteristic, the outer cover 18 is referred to a Moisture Vaopr Transmission Rate film or MVTR film. The products TEGADERM® brand sealing film made by 3M Corporation, and OPSITE FLEXIGRID® brand semi-permeable dressing made by Smith & Nephew can be used for outer cover 18, for example. Outer cover 18 is approximately 0.003 inch (0.076 mm) thick. However, it is within the scope of this disclosure to include any occlusive or semi-occlusive film or outer cover 18 having another thickness. Outer cover 18 is provided to create a sealed environment below the outer cover 18 and around the wound 12 in which a vacuum or negative pressure can be maintained as provided by vacuum source 14. Outer cover 18 therefore creates a vacuum space 58 between outer cover 18 and wound surface 13.

As shown in Fig. 3, bandage 10 may optionally include a packing material or filler 68, such as gauze, for example. Filler 68 is positioned between outer cover 18 and member 30. It is within the scope of this disclosure, however, for bandage 10 to not include filler 68. In other words, outer cover 18 would be positioned adjacent top surface 52 of cover 34 without any packing.

-10-

As shown in Fig. 3, member 30 of bandage 10 includes channels 47 formed in wound contacting surface 38. Wound contacting surface 38 may also be textured or roughened and/or may include a rib, protrusion, channel, or spacer design. By providing member 30 with a rib, protrusion, channel, or spacer, a space is created  
5 between surface 38 of layer 32 and wound surface 13. Through holes 62 communicate with this space to permit vacuum source 14 to establish a generally uniformly distributed vacuum or negative pressure to the wound surface 13 to draw blood from the body to the wound surface 13 and to draw exudate from the wound 12 through holes 62, into channels 44, 46 and passageways 60, and out port 48 of cover  
10 34. It is also within the scope of this disclosure, however, to provide bandage 10 having a smooth wound contacting surface 38.

The vacuum or negative pressure which draws blood from the body to the wound surface 13 and draws exudate from the wound 12 up through member 30 promotes the healing of wound 12. As wound 12 heals, granulations form along the  
15 wound surface 13. Granulations, therefore, are the replacement within the wound bed of tissue lost. As the granulations fill in the wound bed causing the wound 16 to heal, member 30 rides up on the wound surface 13 on top of the granulations which are formed.

As mentioned above, port 48 of cover 34 communicates with vacuum  
20 source 14 and/or irrigation source 16 via connector 36 and tube 24. As shown in Fig. 1, a switch valve 55 is provided which allows the caregiver to switch between the use of the vacuum source 14 and the irrigation source 16. It will be appreciated that a mechanism other than the switch valve 55 may be used selectively to couple the vacuum source 14 or the irrigation source 16 to the bandage 10. Simple tube clamps,  
25 for example, may be used selectively to open and close the tube set provided with bandage 10. When valve 55 is switched to operate the vacuum source 14, the vacuum suction draws exudate up through holes 62 and radially inwardly through passageways 60 toward port 48 and finally through connector 36 and tube 24. Although tube 24 has been referred to as vacuum tube 24, tube 24 may also be used as  
30 an irrigation tube carrying liquid to the wound 12 from irrigation source 16, as described above.

As mentioned above, collar 20 is coupled to outer cover 18 and includes passageway 22 for receiving a portion of tube 24 therethrough, as shown in

-11-

Figs. 3-5. As shown in Fig. 1, tube 24 includes a first region 64, a portion of which is received in passageway 22 of collar 20, and a second region 66 in communication with the vacuum source 14 and/or the irrigation source 16. Collar 20 provides external catheter or tube 24 access to member 30. Collar 20 further provides a substantially airtight lock or seal between tube 24 and outer cover 18. As shown in Fig. 2, 4, and 5, illustrative collar 20 is a retention disc. Various silicone retention discs are available commercially such as the Cook Urological Khonsari Retention Disc, for example. Collar 20 includes a generally flat disc portion 70 and a tube receiver 72 coupled to disc portion 70 and formed to define passageway 22 for receiving a portion of first region 64 of tube 24, as shown in Fig. 3.

Collar 20 includes a slit 74 from passageway 22 to an outer edge 76 of disc portion 70, as shown in Fig. 4. Collar 20 is normally in a closed position, as shown in Fig. 2, and is moved to an opened position, as shown in Fig. 4, where a first surface 78 and a second surface 80 of collar 20 are spaced apart from each other.

Collar 20 further includes a pull-tab 82, as shown in Figs. 4 and 5. Pull-tab 82 is placed around a neck portion 84 of tube receiver 72, as shown in Fig. 4, and pulled tight around neck portion 84 to move collar 20 from the opened position to the closed position where first surface 78 and second surface 80 are adjacent to and engage each other, as shown in Fig. 5. Pull-tab 82 includes a strap 86 having a first end region including ridges 88 and a second end region coupled to a strap-retainer 90 of the pull-tab 82. A portion of the ridged end region of strap 86 extends through strap-retainer 90 so that pull-tab 82 forms a loop, as shown in Fig. 4. A head 73 of tube receiver 72 is placed through the loop of pull-tab 82 to position pull-tab 82 around neck portion 84 of tube receiver 72. A caregiver then pulls the ridged end of strap 86 further through strap-retainer 90 to reduce the size of the loop around neck portion 84 to cause collar 20 to move to the closed position. When pull-tab 82 is pulled tight, strap 86 engages neck portion 84 and is trapped between disc portion 70 and head 73.

As mentioned above, collar 20 is coupled to outer cover 18, as shown in Figs. 3-5. Illustratively, collar 20 is coupled to top surface 19 of outer cover 18. Although top surface 19 of outer cover 18 is coupled to a bottom surface 94 of disc portion 70 of collar 20, it is within the scope of this disclosure to include a bandage where the outer cover 18 is coupled to any outer surface of the collar 20, such as a top

-12-

surface 95 of disc portion 70, for example, so that outer cover 18 and collar 20 are coupled to each other in a substantially airtight manner. It is within the scope of this disclosure, however, to include a bandage having a collar coupled to an outer cover using any suitable means such as an adhesive or adhesives or by heat sealing the outer cover to the collar, for example. It is further within the scope of this disclosure to include a bandage where the collar and the outer cover are manufactured as one component for receiving first end 64 of tube 24 therethrough and for covering wound 12 to attach to the patient's healthy skin 15 surrounding wound 12. As shown in Fig. 3, outer cover 18 further includes an aperture 92 for receiving a portion of first end region 64 of tube 24 therein, as shown in Fig. 3. Aperture 92 of outer cover 18 is aligned with passageway 22 of tube receiver 72 of collar 20 so that tube 24 is able to extend through collar 20 and outer cover 18 to communicate with wound 12 through member 30.

To dress wound 12, a caregiver places member 30 adjacent the wound surface 13. Specifically, wound-contacting surface 38 of layer 32 is placed adjacent wound surface 13. Packing or filler 68 may then be placed over member 30 and wound surface 13, if desired. (However, in many cases, caregivers will not use such packing.) Outer cover 18 and collar 20 coupled to outer cover 18 are next placed over the filler 68, if used, or directly over member 30 adjacent top surface 52 of cover 34. Outer cover 18 is attached to the patient's healthy skin 15 surrounding wound 12, as shown in Fig. 3. First end 64 of tube 24 is then inserted through passageway 22 of tube receiver 72 and aperture 92 of outer cover 18 into vacuum space 58 created by bandage 10. The caregiver then couples tube 24 to connector 36 of member 30.

The caregiver may wish to align connector 36 of member 30 with the already aligned aperture 92 of outer cover 18 and passageway 22 of collar 20 in order to be able to more easily couple first end 64 of tube 24 to connector 36 once tube 24 is inserted through collar 20 and outer cover 18. Once tube 24 is coupled to connector 36, caregiver tightens pull-tab 82 by pulling the ridged end region of strap 86 through strap-retainer 90 until collar 20 is in the closed position having first surface 78 and second surface 80 clamped together. In the closed position, with pull-tab 82 tightened around neck portion 84, collar 20 creates a substantially airtight seal between tube 24 and film 18. Pull-tab 82 can be loosened by the caregiver to allow the caregiver to remove tube 24 if desired. Thus, collar 20 provides for external access through outer

-13-

cover 18 of wound 12 without the need to remove outer cover 18. Collar 20 also maintains a substantially airtight environment when tube 24 extends through collar 20 and outer cover 18.

Referring now to Figs. 6-8, another illustrative embodiment of a collar  
5 120 is shown as a component of bandage 10. Collar 120 is similar to collar 20 and as such, the same reference numerals have been used in Figs. 6-8 to designate similar components to those components previously discussed in regard to Figs. 1-6. Therefore, additional discussion thereof is not warranted.

One difference between collar 120 and collar 20 is that collar 120 does  
10 not include slit 74 defined by first surface 78 and second surface 80. A disc portion 170 therefore of collar 120 does not move between an opened position and a closed position as disc portion 70 does. However, collar 120 includes a thin, elastic membrane 96 across passageway 22 of tube receiver 72, as shown in Fig. 6, for example. In use, the caregiver pushes first end 64 of tube 24 through passageway 22  
15 to break or tear membrane 96. The broken membrane then acts to create a substantially airtight seal between tube 24, neck portion 84 of collar 20, and outer cover 18 without the need for pull-tab 82. Therefore, collars 20 and 120 each provide a substantially airtight seal between outer cover 18 and tube 24 while allowing a caregiver to remove and replace tube 24 without the need to remove and reseal outer  
20 cover 18 around wound 12. Pull-tab 82 and membrane 96 each act as a sealer of collars 20, 120, respectively, to create a seal between tube 24 and collar 20, 120.

Although this invention has been described in detail with reference to certain embodiments, variations and modifications exist within the scope and spirit of the invention as described and defined in the following claims.

-14-

## CLAIMS:

1. A bandage connectable to a vacuum source for use with a wound having a wound surface, the bandage comprising  
5 a flexible cover positioned over the wound and configured to seal to a patient's healthy skin surrounding the wound, the cover including a port, a collar coupled to the cover and including a passageway in communication with the port of the cover, the passageway being configured to receive at least a portion of a tube in communication with the vacuum source, and  
10 a sealer coupled to the collar and configured to provide a substantially airtight seal between the tube and the passageway to create a sealed environment capable of maintaining a negative pressure between the cover and the wound surface.
2. The bandage of claim 1, wherein the collar includes a disc portion coupled to the cover and a tube receiver coupled to the disc portion, and  
15 wherein the tube receiver extends away from the cover and includes the passageway in communication with the port of the cover.
3. The bandage of claim 2, wherein the tube receiver includes a narrow neck portion adjacent the disc portion.
4. The bandage of claim 3, wherein collar includes a slit formed  
20 through the tube receiver and the disc portion and extending outwardly from the passageway to an outer edge of the disc portion to define radially extending first and second surfaces, and wherein the collar is normally in a closed position, where the first and second surfaces are adjacent each other, and is movable to an opened position, where the first surface and the second surface are spaced apart from each  
25 other, to configure the collar to receive the tube at least in part into the passageway.
5. The bandage of claim 4, wherein the sealer is a pull-tab positioned around the neck portion and configured to be tightened around the neck portion to move the slit from the opened position to the closed position.
6. The bandage of claim 2, wherein the sealer is a thin membrane  
30 extending across the passageway of the tube receiver.



-15-

7. The bandage of claim 6, wherein the membrane is broken when the tube inserted at least in part into the passageway of the tube receiver, and wherein the broken membrane creates a seal between the tube and the collar.

8. The bandage of claim 6, wherein the membrane is elastic.

5 9. The bandage of claim 1, wherein the collar is coupled to a top surface of the cover.

10. A vacuum bandage connectable to a vacuum source for providing vacuum treatment to a wound having a wound surface, the vacuum bandage comprising

10 a flexible member positioned to lie adjacent the wound surface, the member configured to communicate with the vacuum source through a vacuum tube coupled to the member and to the vacuum source,

a thin, flexible cover positioned over the member and configured to seal to a patient's healthy skin surrounding the wound, the cover including a port, and

15 a collar coupled to the cover and including a passageway in communication with the port of the cover, the passageway being configured to receive at least a portion of the vacuum tube in communication with the vacuum source or irrigation source, and the collar configured to permit the tube to be removed and replaced while the cover remains sealed to the patient's healthy skin surrounding the  
20 wound.

11. The bandage of claim 10, wherein the collar includes a disc portion and a tube receiver coupled to the disc portion and including the passageway.

12. The bandage of claim 11, wherein the collar is coupled to the top surface of the cover.

25 13. The bandage of claim 10, further including a means for creating a generally airtight seal between the tube and the collar.

14. The bandage of claim 13, wherein the means is a pull-tab for placement around the passageway of the collar, the pull-tab is adjustable about the collar to increase and decrease the size of the passageway within in which the tube is  
30 at lest in part received.

15. The bandage of claim 14, wherein the pull-tab includes a strap having ridges at one end and a strap retainer coupled to the other end and the ridged end is received through the strap retainer to create a loop around the collar.

-16-

16. The bandage of claim 13, wherein the means is a thin, elastic membrane positioned over the passageway and configured to tear when the tube is inserted at least in part into the passageway, and wherein the broken membrane forms a seal between the passageway of the collar and the tube.

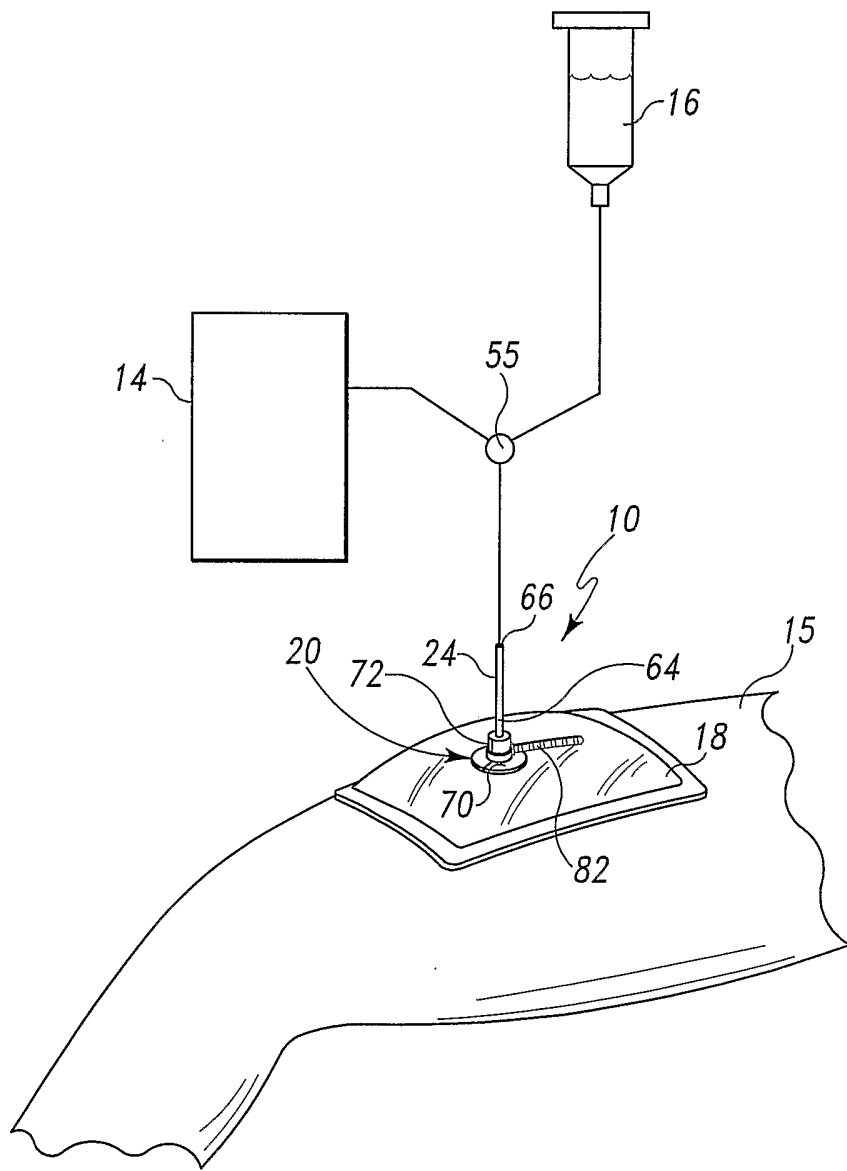
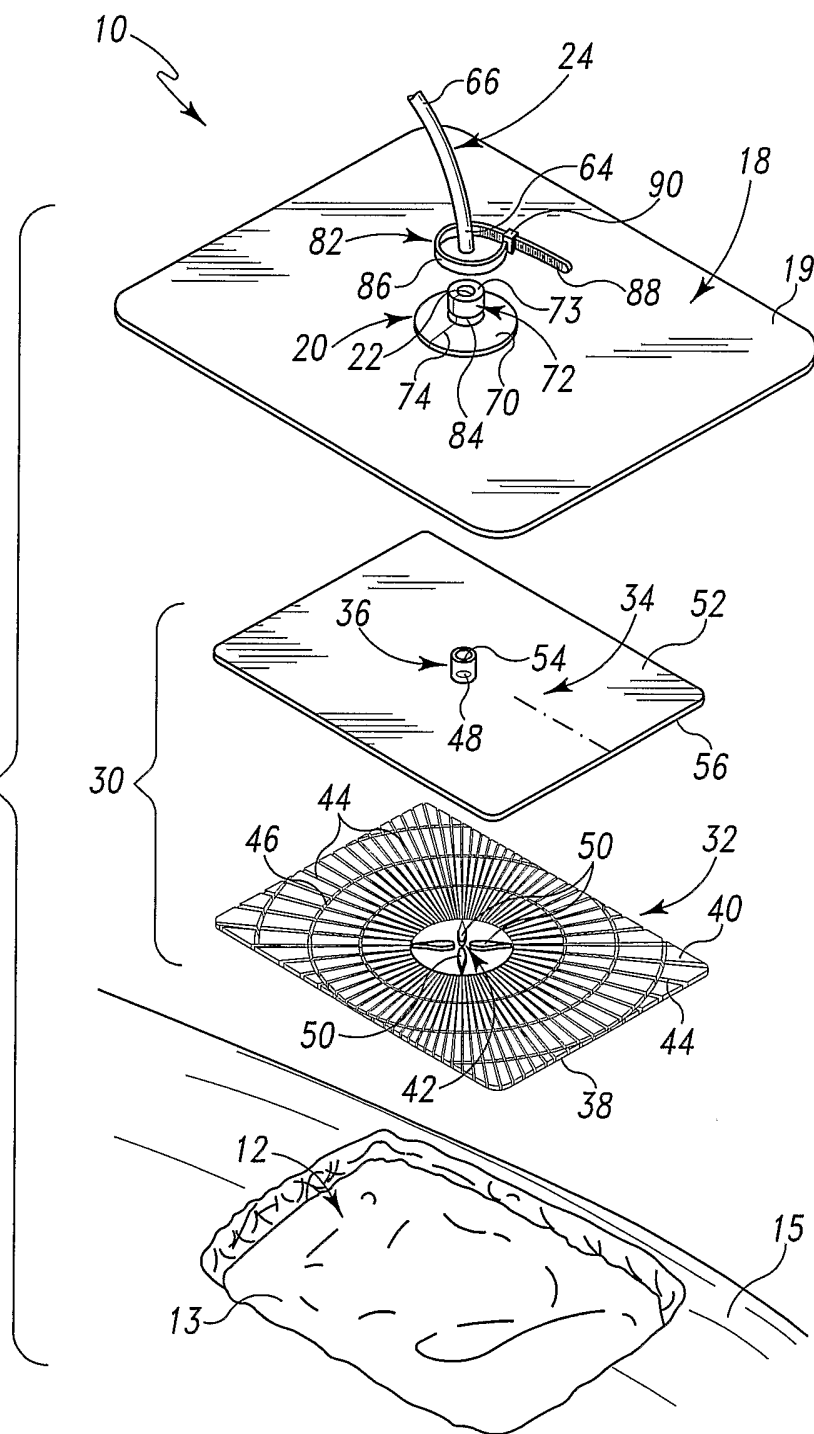

Fig. 1

Fig. 2





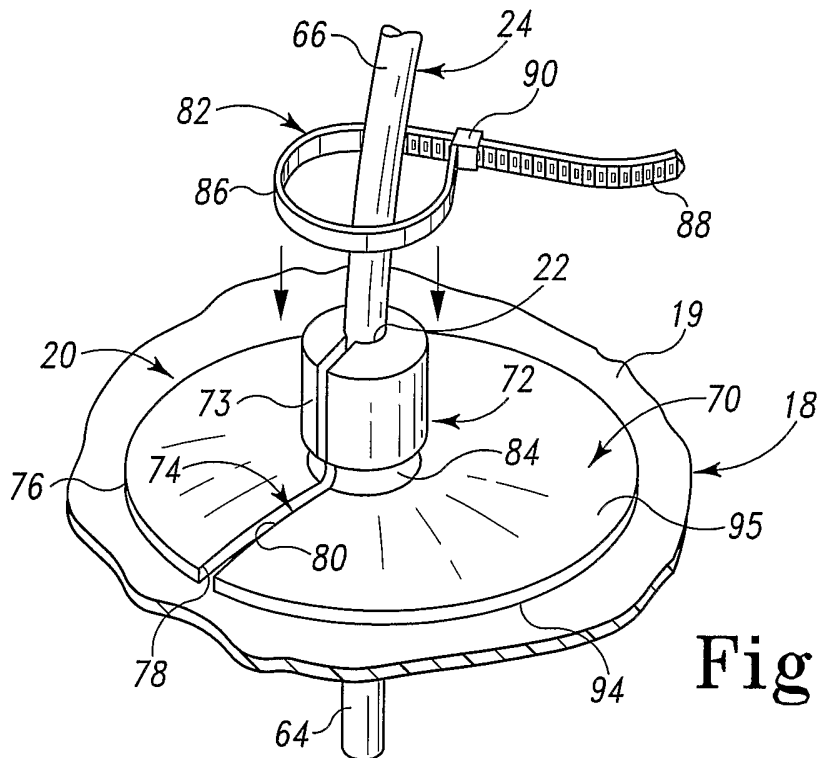

Fig. 4

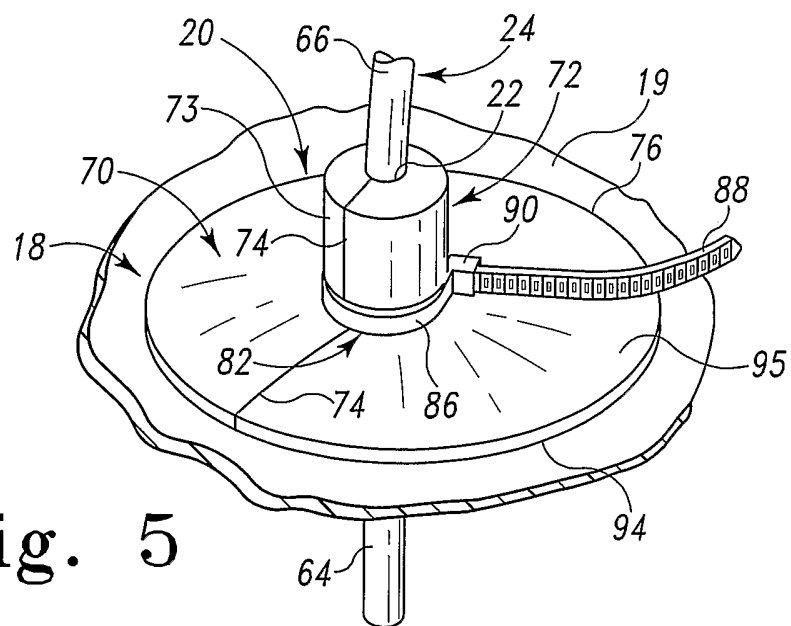

Fig. 5

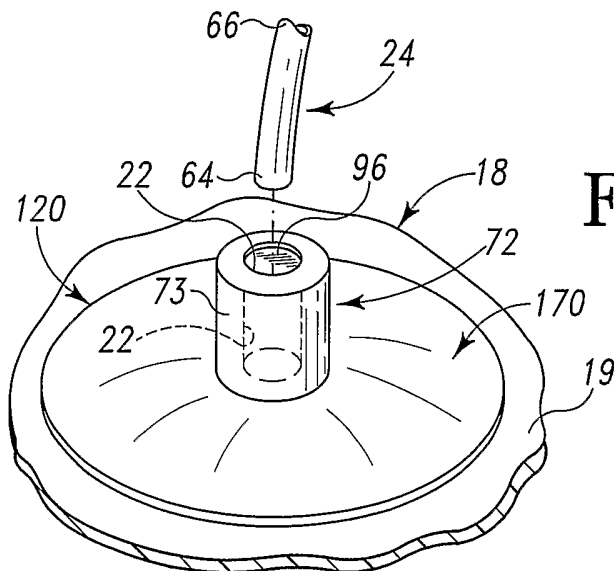

Fig. 6

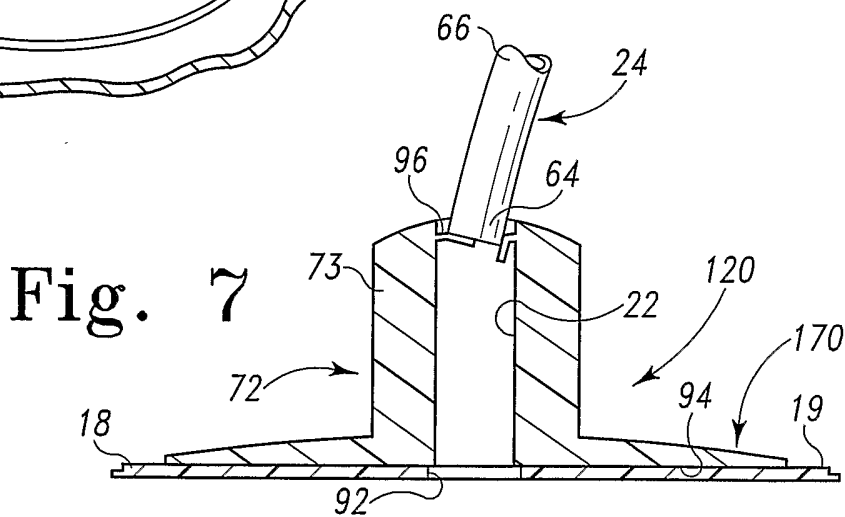

Fig. 7

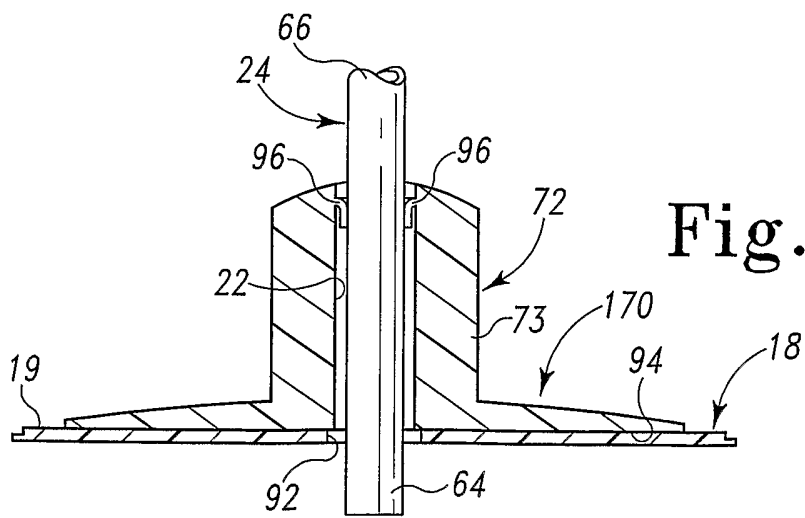

Fig. 8

**INTERNATIONAL SEARCH REPORT**

International application No.

PCT/US02/41300

<b>A. CLASSIFICATION OF SUBJECT MATTER</b>		
IPC(7) : A61F 13/00		
US CL : 604/313		
According to International Patent Classification (IPC) or to both national classification and IPC		
<b>B. FIELDS SEARCHED</b>		
Minimum documentation searched (classification system followed by classification symbols) U.S. : 604/313, 305, 289, 290, 304, 315		
Documentation searched other than minimum documentation to the extent that such documents are included in the fields searched		
Electronic data base consulted during the international search (name of data base and, where practicable, search terms used)		
<b>C. DOCUMENTS CONSIDERED TO BE RELEVANT</b>		
Category *	Citation of document, with indication, where appropriate, of the relevant passages	Relevant to claim No.
Y	DE 197 22 075 C1 (Fleischmann) 01 October 1998 (01.10.1998), Fig.1.	1-16
Y	US 5,782,871 A (Fujiwara et al.) 21 July 1998 (21.07.1998), Figs. 2-10, Abstract.	1-16
Y	US 4,953,565 A (Tachibana et al.) 04 September 1990 (04.09.1990), Figs. 1 and 2.	1-16
Y	US 5,291,887 A (Stanley et al.) 08 March 1994 (08.03.1994), Fig. 4.	1-16
<input type="checkbox"/> Further documents are listed in the continuation of Box C. <input type="checkbox"/> See patent family annex.		
* Special categories of cited documents:		
"A"	document defining the general state of the art which is not considered to be of particular relevance	"T" later document published after the international filing date or priority date and not in conflict with the application but cited to understand the principle or theory underlying the invention
"E"	earlier application or patent published on or after the international filing date	"X" document of particular relevance; the claimed invention cannot be considered novel or cannot be considered to involve an inventive step when the document is taken alone
"L"	document which may throw doubts on priority claim(s) or which is cited to establish the publication date of another citation or other special reason (as specified)	"Y" document of particular relevance; the claimed invention cannot be considered to involve an inventive step when the document is combined with one or more other such documents, such combination being obvious to a person skilled in the art
"O"	document referring to an oral disclosure, use, exhibition or other means	"&" document member of the same patent family
"P"	document published prior to the international filing date but later than the priority date claimed	
Date of the actual completion of the international search	Date of mailing of the international search report	
26 June 2003 (26.06.2003)	31 JUL 2003	
Name and mailing address of the ISA/US	Authorized officer	
Mail Stop PCT, Attn: ISA/US Commissioner for Patents P.O. Box 1450 Alexandria, Virginia 22313-1450	Weilun Lo <i>diane Amara</i>	
Facsimile No. (703)305-3230	Telephone No. 703-306-0858	