



INTERNATIONAL APPLICATION PUBLISHED UNDER THE PATENT COOPERATION TREATY (PCT)

<p>(51) International Patent Classification <sup>6</sup> : <b>A61M 16/04, 16/00</b></p>	<p><b>A1</b></p>	<p>(11) International Publication Number: <b>WO 95/33506</b> (43) International Publication Date: 14 December 1995 (14.12.95)</p>
<p>(21) International Application Number: PCT/GB95/01292 (22) International Filing Date: 5 June 1995 (05.06.95) (30) Priority Data: 9411215.8 4 June 1994 (04.06.94) GB (71)(72) Applicant and Inventor: BRAIN, Archibald, Ian, Jeremy [GB/GB]; Sandford House, Fran Court Gardens, Longcross Road, Longcross, Chertsey, Surrey KT16 0DJ (GB). (74) Agents: WEST, Alan, H. et al.; R G C Jenkins &amp; Co., 26 Caxton Street, London SW1H 0RJ (GB).</p>	<p>(81) Designated States: AM, AT, AU, BB, BG, BR, BY, CA, CH, CN, CZ, DE, DK, EE, ES, FI, GB, GE, HU, IS, JP, KE, KG, KP, KR, KZ, LK, LR, LT, LU, LV, MD, MG, MN, MW, MX, NO, NZ, PL, PT, RO, RU, SD, SE, SG, SI, SK, TJ, TM, TT, UA, UG, US, UZ, VN, European patent (AT, BE, CH, DE, DK, ES, FR, GB, GR, IE, IT, LU, MC, NL, PT, SE), OAPI patent (BF, BJ, CF, CG, CI, CM, GA, GN, ML, MR, NE, SN, TD, TG), ARIPO patent (KE, MW, SD, SZ, UG).  <b>Published</b> <i>With international search report.</i> <i>With amended claims.</i></p>	

(54) Title: A FIBREOPTIC INTUBATING LARYNGEAL MASK AIRWAY

(57) Abstract

A laryngeal mask airway has an airway tube (3) substantially aligned with which there are provided one or two channels (6) containing fibreoptic bundles (7, 8) for emitting and receiving light which is directed into the mask aperture in order to provide a monoscopic or stereoscopic view of the laryngeal anatomy, to facilitate intubation of the trachea while maintaining ventilation of the lungs through the laryngeal mask, or to permit diagnosis or treatment of laryngeal or upper airway pathology.

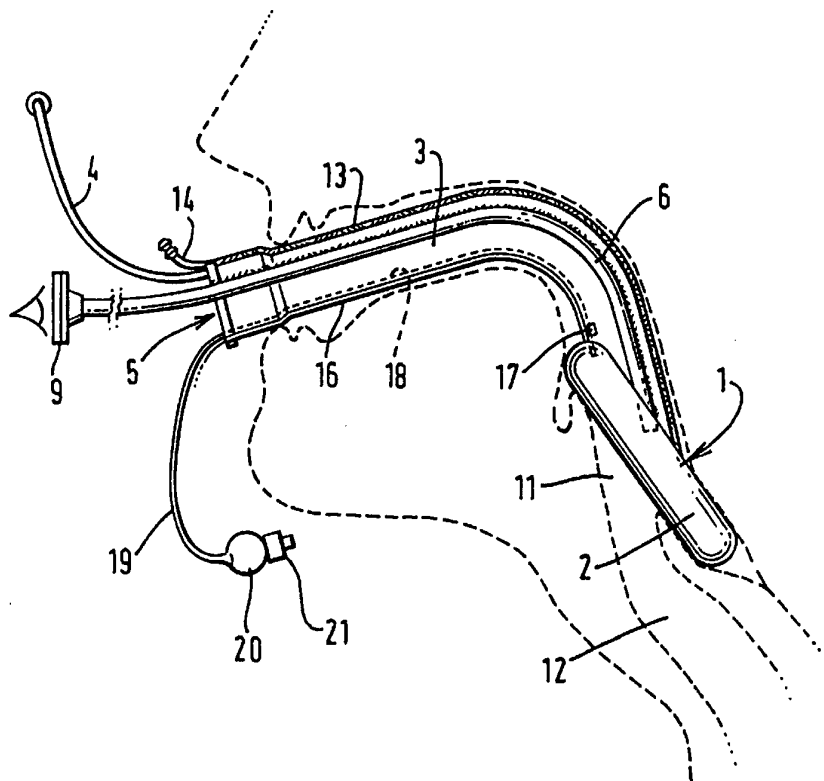

**FOR THE PURPOSES OF INFORMATION ONLY**

Codes used to identify States party to the PCT on the front pages of pamphlets publishing international applications under the PCT.

AT	Austria	GB	United Kingdom	MR	Mauritania
AU	Australia	GE	Georgia	MW	Malawi
BB	Barbados	GN	Guinea	NE	Niger
BE	Belgium	GR	Greece	NL	Netherlands
BF	Burkina Faso	HU	Hungary	NO	Norway
BG	Bulgaria	IE	Ireland	NZ	New Zealand
BJ	Benin	IT	Italy	PL	Poland
BR	Brazil	JP	Japan	PT	Portugal
BY	Belarus	KE	Kenya	RO	Romania
CA	Canada	KG	Kyrgyzstan	RU	Russian Federation
CF	Central African Republic	KP	Democratic People's Republic of Korea	SD	Sudan
CG	Congo	KR	Republic of Korea	SE	Sweden
CH	Switzerland	KZ	Kazakhstan	SI	Slovenia
CI	Côte d'Ivoire	LI	Liechtenstein	SK	Slovakia
CM	Cameroon	LV	Latvia	SN	Senegal
CN	China	LK	Sri Lanka	TD	Chad
CS	Czechoslovakia	LU	Luxembourg	TG	Togo
CZ	Czech Republic	LV	Latvia	TJ	Tajikistan
DE	Germany	MC	Monaco	TT	Trinidad and Tobago
DK	Denmark	MD	Republic of Moldova	UA	Ukraine
ES	Spain	MG	Madagascar	US	United States of America
FI	Finland	ML	Mali	UZ	Uzbekistan
FR	France	MN	Mongolia	VN	Viet Nam
GA	Gabon				

A FIBREOPTIC INTUBATING LARYNGEAL MASK AIRWAY

This invention relates to a fiberoptic intubating laryngeal mask airway device for use in anaesthesia.

Laryngeal mask airway devices are described in  
5 British Patents 2,111,394 and 2,205,499 and in a  
number of corresponding foreign patents and patent  
applications.

Despite the success of such laryngeal mask airway  
(LMA) devices which are now used in some 40% of all  
10 anaesthetic procedures in the United Kingdom,  
intubation of the trachea remains the ultimate  
objective of airway management in an emergency or when  
there may be a risk of inhalation of gastric contents,  
since the presence of a cuffed tube in the trachea  
15 prevents gastric acid present in vomit from entering  
and damaging the lungs. However, intubation of the  
trachea is not always possible and, when difficulty is  
experienced, soiling of the lungs with gastric acid  
may occur while attempts are being made to intubate.  
20 The LMA as described in the above patents has been  
modified as described in British Patent 2,252,502 in  
order to facilitate intubation of the trachea using  
the LMA as a guide, in cases where intubation by  
conventional means using a laryngoscope to visualise  
25 the glottis has failed. However, this intubating  
laryngeal mask (ILM) has the limitation that, for a

high degree of success in passing an endotracheal tube through the ILM tube into the trachea, fibrescopic aid is needed to ensure the endotracheal tube does not pass into the oesophagus or collide with the epiglottis. These hazards, particularly the former which may result in death if undetected, are present also in classical intubation using a laryngoscope. Fibreoptic assisted intubation is another possible technique when classical intubation fails but has the disadvantage that it requires much skill and takes time, a significant drawback in a situation where brain damage or death from lack of oxygen are never more than four minutes away if ventilation cannot be achieved. However, the LMA and the ILM have the advantages that if intubation turns out to be impossible, then the patient can still be kept alive because, unlike the laryngoscope or the fibrescope, the mask part of the LMA or ILM provides an adequate seal around the glottis to permit gentle positive pressure ventilation to be maintained while intubation attempts are taking place. This is an important advantage because in practice death or brain damage occur more often from failure to ventilate the lungs than from lung contamination with gastric contents.

In fibreoptic assisted intubation, the operator has to reach the laryngeal aperture by passing the

fibrescope around the back of the tongue (or through the nasal cavity and nasopharynx) and then passing the tip of the scope downwards until the larynx comes into view. This takes time, as previously stated, and because the scope is of small cross-section relative to the cross-section of the pharynx, it is possible for the tip of the fibrescope to wander to one side or the other of the pharynx on the way down, missing the structures of the laryngeal orifice. In addition, the tip of the scope is not protected from contamination with secretions present in the pharynx or from bleeding provoked by its passage, either or both of which may obscure the operator's view. Another problem is that the view is two-dimensional and the field of vision very restricted. The combination of all these factors makes fiberoptic assisted intubation a difficult skill to acquire and maintain. Lastly, fiberoptic scopes are very expensive and not all hospitals are able to afford or maintain them, which adds to the difficulty of ensuring skill is acquired by physicians who might need to use the technique.

These problems are partly resolved when the LMA or ILM is used as a guide for the fibrescope, since when correctly inserted, the mask part of the LMA or ILM completely fills the space of the lower pharynx when the cuff surrounding the mask is inflated. Time

to first ventilation is very rapid as the device is passed blindly in a single movement. Thus, when using the LMA, a view of the laryngeal inlet is automatically achieved in the great majority of cases simply by inserting the fibrescope down the tube. In other words, the tube-mask assembly acts as a guide, directing the fibrescope to its target. Furthermore, the inspection can be carried out in a leisurely fashion, since ventilation has already been assured as soon as the LMA cuff is inflated. With the ILM, the probability of viewing the larynx is even greater because unlike the LMA its tube is rigid and provided with an external handle, which permits direct manipulation of the mask relative to the larynx, allowing the clinician to alter the position of the mask if perfect alignment is not achieved in the first instance. However, a fibrescope still has to be inserted in the tube to ascertain whether accurate alignment has been achieved.

The present invention seeks to avoid this problem by incorporating into a modified laryngeal mast airway device one or more fibreoptic systems arranged to provide an optimal and preferably binocular view of the laryngeal inlet. This permits the operator to have immediate optical confirmation of the position of the mask aperture relative to the laryngeal inlet from

the moment of insertion of the device and at any time thereafter. A binocular view has the advantage of permitting stereoscopic vision of the anatomy.

In accordance with the present invention, there  
5 is now provided a laryngeal mask airway device to facilitate lung ventilation in an unconscious patient, comprising an airway tube and a mask attached to an end of the airway tube, the mask having an annular peripheral formation of roughly elliptical shape and  
10 being capable of conforming to and readily fitting within the actual and potential space behind the larynx so as to enable the annular peripheral formation to form a seal around the circumference of the laryngeal inlet without the device penetrating  
15 into the interior of the larynx, the annular peripheral formation surrounding the mask into which the airway tube opens, the airway tube being curved to follow the airway of the patient, the device further comprising in alignment with the airway tube at least  
20 one channel adapted to contain a fiberoptic system for receiving and emitting light directed into the mask.

Several advantages accrue from achieving immediate optical confirmation of the position of the mask, as follows.

25 (a) If regurgitant fluid finds its way into the bowl of the mask before intubation of the trachea can

be carried out, then it can immediately be seen and aspirated using a suction catheter before significant lung contamination occurs.

(b) Visual information from the fibrescope can be transferred to a television screen for remote viewing, for example as part of the monitoring equipment on the anaesthetic machine.

(c) As with other monitoring aids, this information can be stored for future use in teaching or as part of the patient's case notes, for example for medico-legal evidence.

(d) The laryngeal view can also be valuable as a teaching aid during routine anaesthesia.

(e) Laryngeal movements indicating inadequate levels of anaesthesia can be seen, permitting early preventive action to avoid the danger of laryngeal spasm or awareness.

(f) The device may be used for diagnosis and treatment of laryngeal or tracheal pathology, for example by ear, nose and throat specialists.

(g) Like the standard LMA, the device can be inserted in the awake patient after application of local anaesthesia to the throat, offering the possibility of treatment and diagnosis of upper airway problems on an outpatient basis.

(h) Most importantly, in the case that



intubation of the trachea with an endotracheal tube is desired, the laryngeal view from the mask aperture will help the clinician to guide the tip of the tube towards the laryngeal aperture by manipulating the handle of the rigid laryngeal mask tube through which the endotracheal tube is passed.

Two forms of laryngeal mask airway device in accordance with the invention will now be described by way of example only with reference to the accompanying drawings, in which:

Figures 1 and 2 are side and front views, respectively, of a first form of the device; and

Figure 3 is a side view of a second form of the device.

Referring first to Figures 1 and 2 of the drawings, the first form of laryngeal mask airway device of the invention comprises a mask body 1 attached to a rigid curved airway tube 3 and surrounded by a generally elliptical peripheral formation, or cuff, 2. The body 1 and cuff 2 are of generally conventional construction and configuration and are described in detail in the patents referred to above. The airway tube 3 is of substantially rigid construction and may be made of plastics material, carbon fibre, metal or any combination of these materials and has an exterior handle 4 and

incorporates a main airway lumen 5, and one or two additional channels 6 running on one or both sides and substantially parallel to the plane of curvature of lumen 5. The channel(s) 6 accommodate fibreoptic bundles 7 incorporating fibres connected to a light source (not shown) which may be remote from the airway device or incorporated for example in its handle 4. Running alongside the fibreoptic bundles 7 are separate fibre bundles 8 whose functions is to transmit the image of the object so illuminated to the observer's eyes, those separate fibre bundles 8 being sheathed in visible-light impermeable material and running from independently focusable eyepiece or eyepieces 9 situated so as to avoid encumbering intubation attempts. Both fibre bundles 7 and 8 terminate within or close to the airway opening 10 of the mask at such an angle as to offer a view of the larynx and in the case of two separate channels 6 each such channel is suitably directed with respect to the other so as to provide a stereoscopic view of the larynx 11 to the observer viewing through eyepieces 9. Additionally, the combined light-source carrying and viewing fibreoptic bundles 7 and 8 may be moveable within channels 6 so as to permit an observer to obtain varying views of anatomical structures in the region of the larynx. Additionally, again, fibreoptic

bundles 7 and 8 may be of sufficient length to permit their entry into the trachea 12 or bronchi should examination of these structures be desired. In the preferred case where there are provided two separate  
5 fibreoptic channels 6, fibreoptic bundles 7 and 8 are preferably independently moveable in their respective channels so that it is possible to view simultaneously two different anatomical regions, permitting for example the effect of stimulation or treatment on one  
10 region to be seen on another region remote from the region of such treatment or stimulation.

In addition to the main airway tube 3 and channel or channels 6, there is provided optionally a further channel 13 which runs substantially parallel to airway  
15 tube 3 and may be disposed at any point in the circumference on the wall of airway tube 3 but is preferably sited in the midline of the convex surface of curvature of airway tube 3. This additional channel 13 opens at the outer or mouth end of the  
20 device into a tube 14 suitable for attachment to plastics disposable suction catheters (not shown) and opening at the laryngeal end into the mask where it forms a drain 15 for collection of secretions from the lungs, pharynx or stomach, blood, foreign bodies or  
25 food particles. The drain 15, channel 13 and tube 14 are of sufficient diameter to permit passage of

suction catheters (for example, of 5-6 mm diameter in adults).

Optionally, there may further be provided in the wall of main airway tube 3 a small channel 16 (for example, of approximately 1 mm internal diameter) which connects externally of the patient to a tube of similar diameter leading to a device (not shown) known as a capnometer for measuring end-tidal carbon dioxide concentrations in exhaled breath. The channel 16 terminates at gas sampling site 17 within the interior lumen of main airway tube 3 near to its junction with mask 1.

Again optionally, there may be provided a further small channel 18 (for example, of approximately 0.5 mm internal diameter) running longitudinally in the wall of main airway tube 3, the external opening of that channel 18 connecting to a flexible tube 19 which in turn connects with a pilot balloon 20 and self-sealing valve 21 suitable for gas-tight insertion of a disposable syringe for inflation of the device with air. The internal end of that channel 18 communicates with the interior of the inflatable cuff 2 so that the cuff may be inflated or deflated via that channel 18.

Additionally it should be understood that airway tube 3 is provided with easily removable friction-fit (15 mm) connector (not shown) designed for attachment

to conventional anaesthetic gas hosing, in order that the device may be used alone to ventilate the lungs of a patient, without using the intubation facility. It should also be understood that to prevent loss of  
5 airway pressure, channels 6, 13 and 16 are provided with means (not shown) to prevent leakage of gas through them to the exterior when gas is delivered under pressure through main airway tube 3.

In the alternative form of laryngeal mask airway  
10 device shown in Fig. 3 of the accompanying drawings, the airway tube 3' is of softer and of more pliable construction and includes along its outer radius a channel 13' similar to the channel 13 in the device shown in Fig. 1 but of larger diameter, and which may  
15 be closed by a bung 22. In this construction, the rigid handle 4' extends into and along that channel 13' at least during insertion of the device into the patients, and after the device had been properly positioned the handle 4' may be removed. The channel  
20 13' may then be used in the same manner as the channel 13 in the device shown in Fig. 1 for aspirating any unwanted fluids or secretions, as described above. Still further, the channel 13' may be of sufficiently large diameter to pass a removable fiberoptic scope,  
25 thereby obviating the need for the channels 6 and dedicated fiberoptic bundles 7 and 8 in the device

shown in Fig. 1. In this connection, the enlarged diameter channel 13' will of course present a correspondingly enlarged drain 15' close to the airway opening 10 of the mask and through which the  
5 fibreoptic scope will be able to obtain an acceptable image of the patient's larynx. As shown in Fig. 3, the other features of the device shown in Fig. 1 are retained and the same reference numerals have been used in Fig. 3 to identify them.

10 The novel features of the present invention may be incorporated into any form of laryngeal mask device and should not be considered to be restricted to incorporation in the forms of the device detailed above. For example, the gastro-laryngeal mask  
15 described in US Patent 5,241, 956 and containing a facility for drainage of oesophageal discharge in addition to an extra posteriorly placed cuff for greater sealing efficacy, may with advantage be adapted to include the features described herein, as  
20 may the laryngeal mask fitted with a reflectance type oximeter described in US Patent 5,282,464.

CLAIMS:

1. A laryngeal mask airway device to facilitate lung ventilation in an unconscious patient, comprising an airway tube (3,3') and a mask (1) attached to an end of the airway tube, the mask having an annular peripheral formation (2) of roughly elliptical shape and being capable of conforming to and readily fitting within the actual and potential space behind the larynx so as to enable the annular peripheral formation to form a seal around the circumference of the laryngeal inlet without the device penetrating into the interior of the larynx (11), the annular peripheral formation surrounding the mask into which the airway tube opens, the airway tube being curved to follow the airway of the patient, the device further comprising in alignment with the airway tube at least one channel (6,13') adapted to contain a fiberoptic system (7,8) for receiving and emitting light directed into the mask.

2. A device according to claim 1, wherein two channels (6) are located along the sides of the airway tube (3).

3. A device according to claim 1 or claim 2, which includes also a further channel (13) aligned

with the airway tube (3) and opening into the mask (1) forming a drain for secretions from the lungs, pharynx or stomach.

4. A device according to claim 1, wherein the  
5 channel (13') is located along the outer radius of the airway tube (3') and forms also a drain for secretions from the lungs, pharynx or stomach.

5. A device according to any one of claims 1 to  
10 4, which includes also a still further channel (16) aligned with the airway tube (3) for connection to a capnometer.



## AMENDED CLAIMS

[received by the International Bureau on 17 November 1995(17.11.95);  
new claim 6 added; remaining claims unchanged (1 page)]

with the airway tube (3) and opening into the mask (1)  
forming a drain for secretions from the lungs, pharynx  
or stomach.

5 4. A device according to claim 1, wherein the  
channel (13') is located along the outer radius of the  
airway tube (3') and forms also a drain for secretions  
from the lungs, pharynx or stomach.

10 5. A device according to any one of claims 1 to  
4, which includes also a still further channel (16)  
aligned with the airway tube (3) for connection to a  
capnometer.

15 6. A device according to claim 1, wherein the  
airway tube (3') is pliable and wherein the channel  
(13') is located along the outer radius of the airway  
tube and is adapted to receive a rigid handle (4').

1/2

FIG. 1

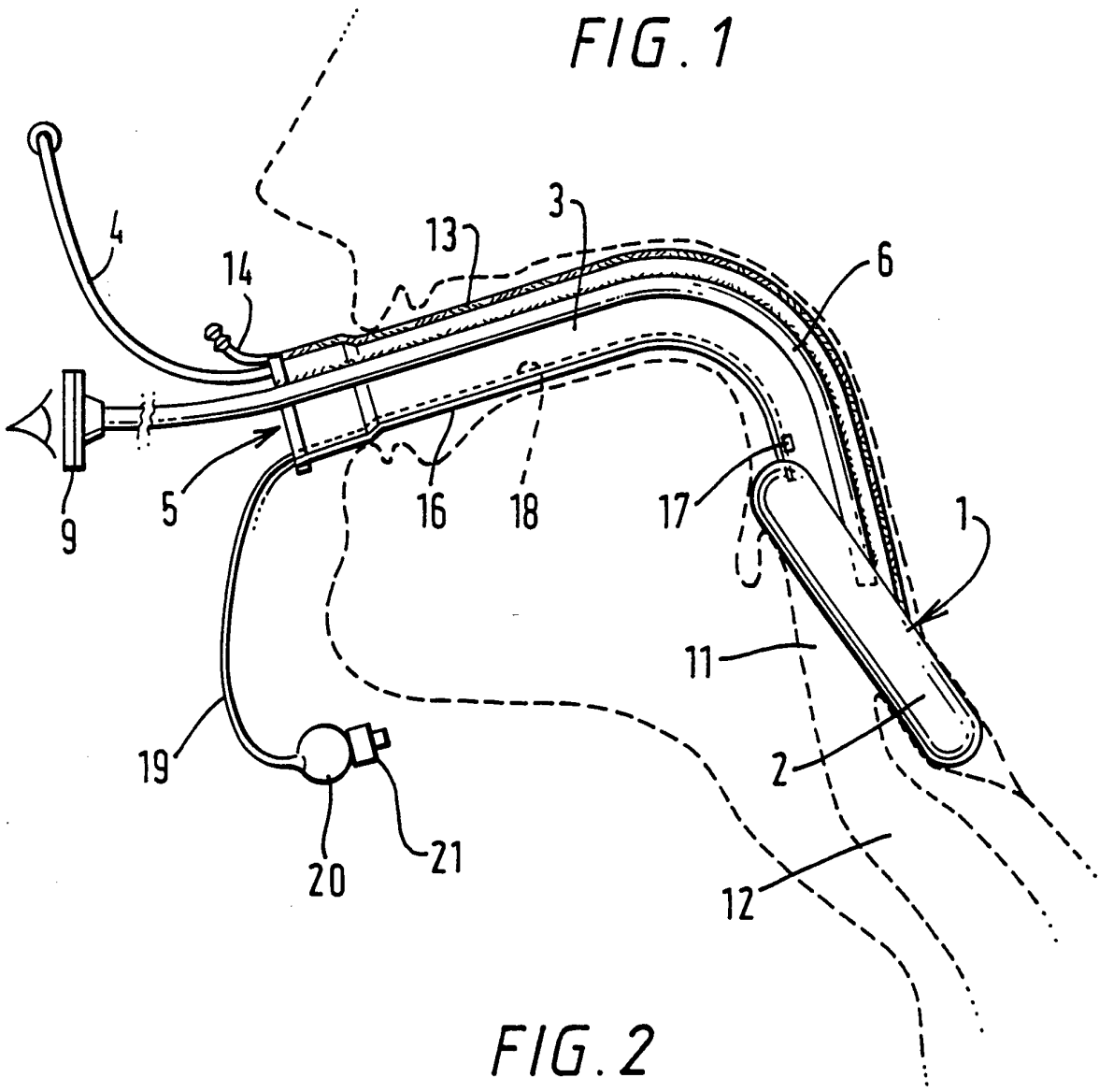
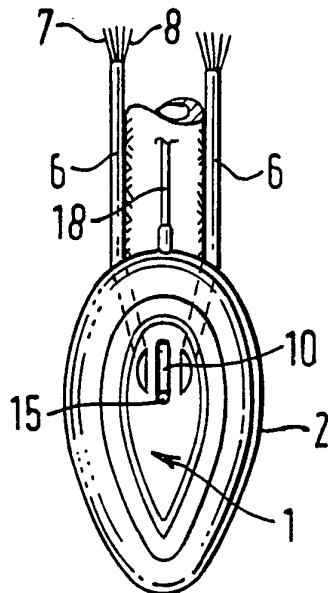
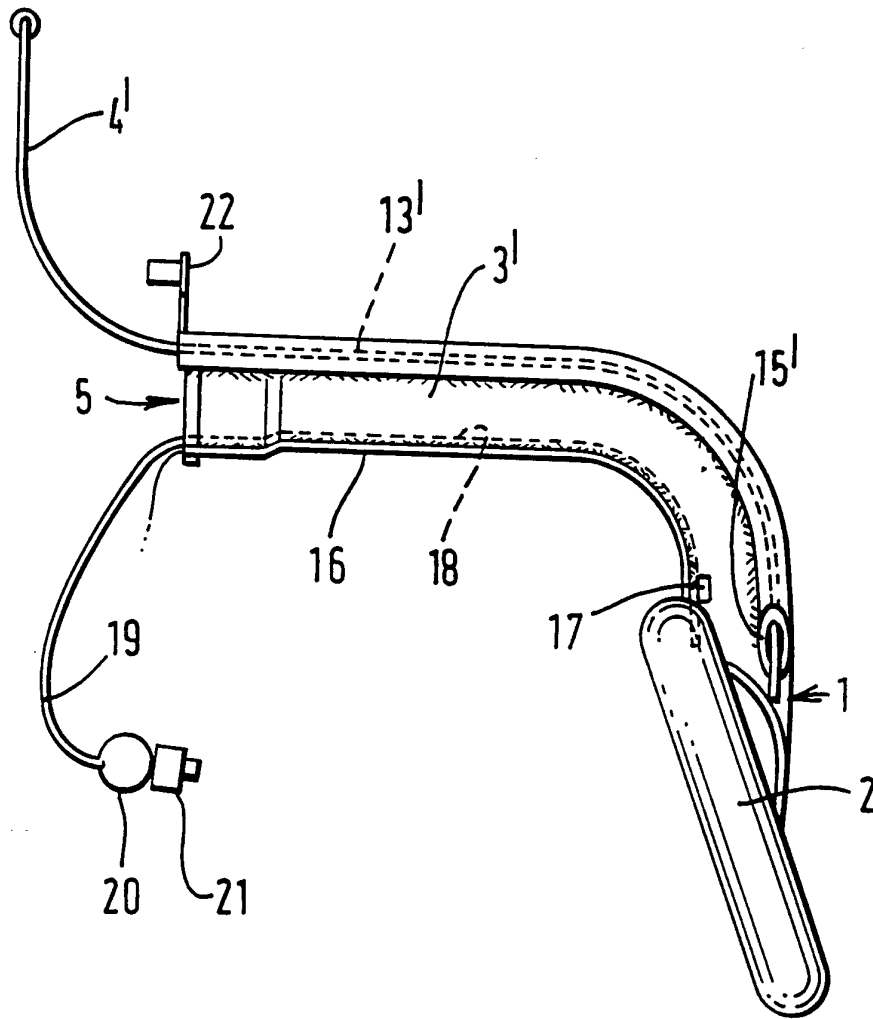

FIG. 2



2/2

FIG. 3



# INTERNATIONAL SEARCH REPORT

International Application No

PCT/GB 95/01292

A. CLASSIFICATION OF SUBJECT MATTER  
 IPC 6 A61M16/04 A61M16/00

According to International Patent Classification (IPC) or to both national classification and IPC

**B. FIELDS SEARCHED**

Minimum documentation searched (classification system followed by classification symbols)  
 IPC 6 A61M A61B

Documentation searched other than minimum documentation to the extent that such documents are included in the fields searched

Electronic data base consulted during the international search (name of data base and, where practical, search terms used)

**C. DOCUMENTS CONSIDERED TO BE RELEVANT**

Category *	Citation of document, with indication, where appropriate, of the relevant passages	Relevant to claim No.
Y	WO,A,92 13587 (BRAIN) 20 August 1992 cited in the application see claim 1; figures 1,2 ---	1,3,4
Y	WO,A,91 07201 (PARKER) 30 May 1991 see page 35, line 4 - line 19; figures 9-11 see page 39, line 8 - page 40, line 8 ---	1,3,4
A	US,A,5 285 778 (MACKIN) 15 February 1994 see column 2, line 55 - column 3, line 2; figure 3 ---	1,2
A	US,A,4 976 261 (GLUCK ET AL.) 11 December 1990 see column 5, line 7 - line 19 -----	5

Further documents are listed in the continuation of box C.

Patent family members are listed in annex.

\* Special categories of cited documents :

- "A" document defining the general state of the art which is not considered to be of particular relevance
- "E" earlier document but published on or after the international filing date
- "L" document which may throw doubts on priority claim(s) or which is cited to establish the publication date of another citation or other special reason (as specified)
- "O" document referring to an oral disclosure, use, exhibition or other means
- "P" document published prior to the international filing date but later than the priority date claimed

- "T" later document published after the international filing date or priority date and not in conflict with the application but cited to understand the principle or theory underlying the invention
- "X" document of particular relevance; the claimed invention cannot be considered novel or cannot be considered to involve an inventive step when the document is taken alone
- "Y" document of particular relevance; the claimed invention cannot be considered to involve an inventive step when the document is combined with one or more other such documents, such combination being obvious to a person skilled in the art.
- "&" document member of the same patent family

Date of the actual completion of the international search

22 September 1995

Date of mailing of the international search report

05. 10. 95

Name and mailing address of the ISA

European Patent Office, P.B. 5818 Patentlaan 2  
 NL - 2280 HV Rijswijk  
 Tel. (+31-70) 340-2040, Tx. 31 651 epo nl,  
 Fax: (+31-70) 340-3016

Authorized officer

Villeneuve, J-M

**INTERNATIONAL SEARCH REPORT**

International Application No  
PCT/GB 95/01292

Patent document cited in search report	Publication date	Patent family member(s)	Publication date
WO-A-9213587	20-08-92	AU-B- 653786	13-10-94
		AU-B- 1238392	07-09-92
		BR-A- 9205612	26-07-94
		EP-A- 0571439	01-12-93
		GB-A, B 2252502	12-08-92
		US-A- 5303697	19-04-94
-----			
WO-A-9107201	30-05-91	US-A- 5038766	13-08-91
		AU-B- 647437	24-03-94
		AU-A- 6895991	13-06-91
		CA-A- 2067782	09-05-91
		CN-A- 1051511	22-05-91
		EP-A- 0500778	02-09-92
		IL-A- 96206	28-11-94
		JP-T- 5501660	02-04-93
		NZ-A- 235907	26-01-94
		US-A- 5174283	29-12-92
		US-A- 5339805	23-08-94
		-----	
US-A-5285778	15-02-94	NONE	
-----			
US-A-4976261	11-12-90	NONE	
-----			