



US00D676164S

(12) **United States Design Patent**
Tada et al.

(10) **Patent No.:** **US D676,164 S**

(45) **Date of Patent:** **** Feb. 12, 2013**

(54) **FRONT COMBINATION LAMP FOR AN
AUTOMOBILE**

(75) Inventors: **Hiroyuki Tada**, Nagoya (JP); **Masayuki Yamaji**, Miyoshi (JP); **Syouta Asano**, Toyota (JP)

(73) Assignee: **Toyota Jidosha Kabushiki Kaisha**, Toyota-shi (JP)

(**) Term: **14 Years**

(21) Appl. No.: **29/424,057**

(22) Filed: **Jun. 7, 2012**

(30) **Foreign Application Priority Data**

Mar. 9, 2012 (JP) 2012-005399

(51) **LOC (9) Cl.** **26-06**

(52) **U.S. Cl.** **D26/28**

(58) **Field of Classification Search** D26/26-36;
362/459-468, 475-478, 485-487

See application file for complete search history.

(56) **References Cited**

U.S. PATENT DOCUMENTS

D528,681	S	*	9/2006	Nakahara	D26/28
D528,685	S	*	9/2006	Yoshida	D26/28
D544,114	S	*	6/2007	Ohta	D26/28
D544,614	S	*	6/2007	Markefka	D26/28
D549,857	S	*	8/2007	Lin	D26/28
D556,349	S	*	11/2007	Golden et al.	D26/28
D561,358	S	*	2/2008	Tachibana	D26/28

OTHER PUBLICATIONS

AutoCone.com; FunCargo; Mfg.: Toyota; <http://autoc-onejp/toyota/funcargo/photo/2/> 2004.

Yunyusa no subete 2007; Kangoo; Mfg.: Renault; Publisher: San-eishobo Publishing Co., Ltd.; May 6, 2007.

Yunyusa no subete 2007; Peugeot 1007; Mfg.: Renault; Publisher: San-eishobo Publishing Co., Ltd.; May 6, 2007.

* cited by examiner

Primary Examiner — Marcus Jackson

(74) *Attorney, Agent, or Firm* — Finnegan, Henderson, Farabow, Garrett & Dunner, LLP

(57) **CLAIM**

The ornamental design for a front combination lamp for an automobile, as shown and described.

DESCRIPTION

FIG. 1 is a perspective view of a front combination lamp for an automobile showing our new design;

FIG. 2 is a front view thereof;

FIG. 3 is a rear view thereof;

FIG. 4 is a right side elevation view thereof;

FIG. 5 is a left side elevation view thereof;

FIG. 6 is a top plan view thereof; and,

FIG. 7 is a bottom view thereof.

Our design includes a mirror image of the embodiment depicted.

1 Claim, 4 Drawing Sheets

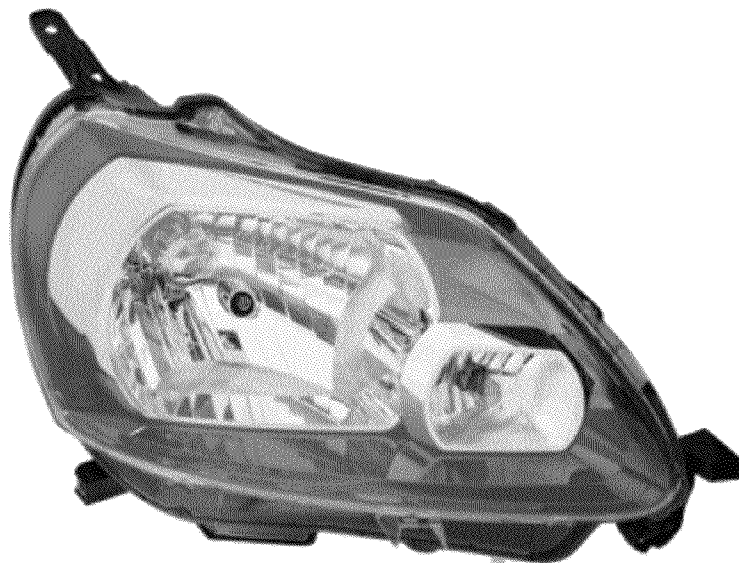



FIG. 1



FIG. 2

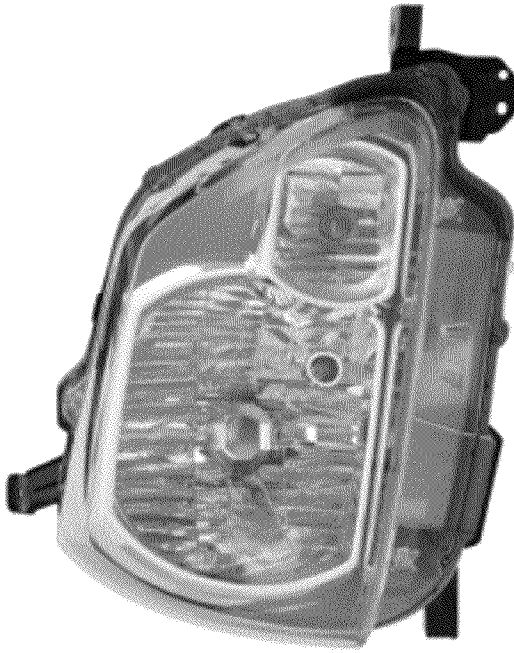

FIG. 3



FIG. 5



FIG. 4



FIG. 7



FIG. 6