



INTERNATIONAL APPLICATION PUBLISHED UNDER THE PATENT COOPERATION TREATY (PCT)

<p>(51) International Patent Classification ⁶ : H04N 7/50</p>	<p>A1</p>	<p>(11) International Publication Number: WO 97/32436</p> <p>(43) International Publication Date: 4 September 1997 (04.09.97)</p>
<p>(21) International Application Number: PCT/EP97/00863</p> <p>(22) International Filing Date: 22 February 1997 (22.02.97)</p> <p>(30) Priority Data: 96103269.5 2 March 1996 (02.03.96) EP (34) Countries for which the regional or international application was filed: DE et al.</p> <p>(71) Applicant (for all designated States except US): DEUTSCHE THOMSON-BRANDT GMBH [DE/DE]; Hermann-Schwer-Strasse 3, D-78048 Villingen-Schwenningen (DE).</p> <p>(72) Inventors; and (75) Inventors/Applicants (for US only): BLAWAT, Meinolf [DE/DE]; Isernhagener Strasse 18, D-30161 Hannover (DE). HERPEL, Carsten [DE/DE]; Große Barlinge 61, D-30171 Hannover (DE).</p> <p>(74) Agent: HARTNACK, Wolfgang; Deutsche Thomson-Brandt GmbH, Licensing and Intellectual Property, Göttinger Chaussee 76, D-30453 Hannover (DE).</p>		<p>(81) Designated States: AU, BR, CN, JP, KR, SG, US, European patent (AT, BE, CH, DE, DK, ES, FI, FR, GB, GR, IE, IT, LU, MC, NL, PT, SE).</p> <p>Published With international search report.</p>
<p>(54) Title: METHOD AND APPARATUS FOR ENCODING OR DECODING DIGITAL VIDEO DATA</p>		
<p>(57) Abstract</p> <p>In a constant bit rate coder the kernel MPEG encoder circuit is followed by a buffer of a certain physical size. This buffer is used to smooth the variable bit rate output of the kernel MPEG encoder. The video buffering verifier (VBV) is a concept used in encoder control that gives an upper bound for the usable encoder buffer size as well as the minimum buffer size needed by a decoder to decode all bitstreams. The quantiser control parameters can vary more - thereby improving the resulting picture quality - if a virtual buffer size is introduced which is greater than the size of the physical buffer. The bit rate control is intended for applications using storage devices with the capability to process a variable bit rate data stream (DVD). Therefore the encoder control strategy is adapted to this situation. For the first e.g. 80 % of the total playing time an average bit rate is produced which is e.g. 95 % only of the normal average bit rate. For the remaining 20 % of the playing time the value for the desired average bit rate ascends to e.g. 150 % of the normal value. During the first 80 % the virtual buffer size is increased by a factor of e.g. 100 whereas during the last 20 % the virtual buffer size descends to the normal value.</p>		

FOR THE PURPOSES OF INFORMATION ONLY

Codes used to identify States party to the PCT on the front pages of pamphlets publishing international applications under the PCT.

AM	Armenia	GB	United Kingdom	MW	Malawi
AT	Austria	GE	Georgia	MX	Mexico
AU	Australia	GN	Guinea	NE	Niger
BB	Barbados	GR	Greece	NL	Netherlands
BE	Belgium	HU	Hungary	NO	Norway
BF	Burkina Faso	IE	Ireland	NZ	New Zealand
BG	Bulgaria	IT	Italy	PL	Poland
BJ	Benin	JP	Japan	PT	Portugal
BR	Brazil	KE	Kenya	RO	Romania
BY	Belarus	KG	Kyrgystan	RU	Russian Federation
CA	Canada	KP	Democratic People's Republic of Korea	SD	Sudan
CF	Central African Republic	KR	Republic of Korea	SE	Sweden
CG	Congo	KZ	Kazakhstan	SG	Singapore
CH	Switzerland	LI	Liechtenstein	SI	Slovenia
CI	Côte d'Ivoire	LK	Sri Lanka	SK	Slovakia
CM	Cameroon	LR	Liberia	SN	Senegal
CN	China	LT	Lithuania	SZ	Swaziland
CS	Czechoslovakia	LU	Luxembourg	TD	Chad
CZ	Czech Republic	LV	Latvia	TG	Togo
DE	Germany	MC	Monaco	TJ	Tajikistan
DK	Denmark	MD	Republic of Moldova	TT	Trinidad and Tobago
EE	Estonia	MG	Madagascar	UA	Ukraine
ES	Spain	ML	Mali	UG	Uganda
FI	Finland	MN	Mongolia	US	United States of America
FR	France	MR	Mauritania	UZ	Uzbekistan
GA	Gabon			VN	Viet Nam

Method and Apparatus for encoding or decoding digital video data

The present invention relates to a method and to an apparatus for encoding and decoding digital video data for and from, respectively, storage media having a given data storage capacity.

10 Background

ISO/IEC 13818 "Information Technology - Generic coding of moving pictures and associated audio information: Video" (MPEG2) discloses an International standard concerning coded digital video and audio data streams. Due to varying picture content the generated amount of code varies over time. However, in case of fixed channel capacity normally a constant bit rate (CBR) MPEG encoder control is desired which can be achieved by using an encoder buffer at transmission side and a decoder buffer at receiver side which is explained in more detail in annexes C and D.4 of said International standard. The other mode is variable bit rate (VBR) coding.

25 Invention

If there is any digital storage medium like DVD (digital video disc) which is capable of variable bit rate operation it might be possible to improve the coding quality by using variable bit rate coding instead of constant bit rate coding.

It is one object of the invention to disclose a method of variable bit rate encoding for a fixed-capacity storage medium in which the coding quality is basically improved compared to that of constant bit rate encoding. This object is achieved by the method disclosed in claim 1.

It is a further object of the invention to disclose a method of variable bit rate decoding from a fixed-capacity storage medium in which the decoding quality is basically improved compared to that of constant bit rate decoding. This object is achieved by the method disclosed in claim 2.

It is a further object of the invention to disclose an encoding and a decoding apparatus which utilises the inventive encoding and decoding method, respectively. This object is achieved by the apparatuses disclosed in claims 3 and 4.

It is a further object of the invention to disclose a digital video signal which is encoded or decoded according to the inventive method. This object is achieved by the signal disclosed in claim 5.

"Constant bit rate" shall mean a constant number of bits output to the channel (or e.g. the Systems multiplexer) in each field period (20ms in a 50Hz TV signal), while "variable bit rate" shall cover all other bit delivery schedules.

In a CBR environment the kernel MPEG encoder circuit is followed by a buffer of a certain size. This buffer is used to smooth the inherently variable bit rate output of the kernel MPEG encoder. The video buffering verifier VBV is a concept used in encoder control that gives an upper bound for the usable encoder buffer size as well as the minimum buffer size needed by a decoder to decode all bit streams compliant to this profiles @ levels (P@L). For all defined profiles @ levels maximum VBV_buffer_size values are specified in clause 8 of ISO/IEC 13818-2. Smaller values are also allowed and can be signalled in each bitstream by the VBV_buffer_size element.

In a variable bit rate application there is no urgent need to use the encoder buffer to smooth the bit rate, however, it might still be useful to retain the buffer, as will become evident below. So the change is that the channel bit rate is variable now.

In both, CBR and VBR applications, the MPEG encoder and the MPEG decoder operate by using the well-known hybrid DPCM/DCT structures.

The bit rate control goals for applications using storage
5 devices with the capability to process a variable bit rate data stream differ from the CBR case. It can now be desirable to:

- maintain uniform quality over time;
- maximise storage time on a medium of a given capacity.

10

Therefore the encoder control strategy needs to be adapted to this situation.

To ease understanding the encoder control for the CBR case shall be reviewed first.

15

The conventional encoder control strategy consists of three steps or control levels:

1) *bit allocation* (global control):

20 The allocation of bits to the different coded frame types (I, P, B frames) is determined according to their relative complexity X_i , X_p , X_b . The goal is to equalise the subjective quality of the frame types. In the following feedback implementation, which does not carry out any pre-analysis,
25 it is assumed that video scenes are sufficiently stationary for some time, so that information from the past frames can be used for the bit allocation to the coming frame or field, depending on the coding structure. In the remainder of the specification, "frame" may generally denote a frame or a
30 field or any other section of a GOP which is greater than a unit (to be defined below).

The complexity can be estimated by any criterion reflecting the relative coding cost for I, P, and B frames at a given image quality. However, it should be considered whether the
35 necessary measurements can be obtained without too much burden on the encoder complexity.

First the "image quality" should be measured. However, it is well known that no commonly agreed, sufficiently simple, ob-

jective measure exists. Therefore, usually the signal-to-noise ratio (SNR) of the reconstructed frame is taken as an approximation to image quality. In the context of an MPEG encoder control even this measure is somewhat costly as it involves computation of SNR for each encoded frame. Therefore the average quantiser step size (Q_i , Q_p , Q_b) used to code a frame is taken as a quality indicator instead. Now, having defined a measure for "quality", the "complexity" of a frame can be expressed as the product of bits generated and the quantiser step size used. In other words: a frame is complex to code if it produces many bits even if the quantiser step size is coarse. This product is formed for each unit m (e.g. macroblock or block or slice or any section which is smaller than a frame) and then summed over the frame:

$$x_m = b_m * q_m \quad (1a)$$

$$X_C = \sum x_m, \quad (1b)$$

wherein b_m is the number of bits for coding unit m , q_m is the average quantiser step size used in unit m , and $c = i, p$ or b is the coding type.

At the beginning of each Group Of Pictures GOP the bit budget $B_G(g)$ available for the current GOP g , considering also a carry $B_G(g-1)$ from the previous GOP, is

$$B_F(n=0) = B_G(g) = (\text{bit rate}) * (\text{frames per GOP}) / (\text{frame rate}) - B_G(g-1) \quad (2)$$

For each frame n in the current GOP, a target number of bits T_C , depending on its coding type c , is determined according to the computed complexity and the remaining number of frames of each coding type (N_i , N_p , N_b) within the current GOP. Considering the remaining bits $B_F(n)$ after coding frame $n-1$ of the GOP, the following formula can be used:

$$T_C = B_F(n) * (X_C * K_C) / (N_i * X_i * K_i + N_p * X_p * K_p + N_b * X_b * K_b) \quad (3)$$

The factors K_C are used to reflect different visual importance of frame coding types, typically $K_i = K_p = 1$ and $K_b < 1$.

5 The complexity computation according to equations (1a) and (1b) is normally updated after each frame, using data from the most recent I, P and B frames, to ensure a reasonable response to scene changes. The bit budget

$$B_F(n+1) = B_F(n) - \sum b_m \quad (4)$$

10 for the remaining frames of the GOP, after subtracting the number of bits $\sum b_m$ used for the current frame, is re-distributed using formula (3) with N_i , N_p , N_b set to the remaining number of frames of each type.

After coding the last frame N of the GOP, the remaining bits
15 $B_G(g) = B_F(N)$ are carried to the next GOP $g+1$.

It is also possible to explicitly allow a non-constant amount of bits per GOP, keeping only the long-time average bit rate constant. Practically this can be implemented by re-filling the bit budget $B_F(n)$ after each frame using
20 $B_F(n) = B_F(n-1) - \sum b_m + (\text{bit rate})/(\text{frame rate}) \quad (5)$

instead of re-filling the budget only at the start of a GOP using equation (2). This budget will then always be distributed according to the number of I, P and B frames in a GOP, rather than only on the remaining frames in the current GOP.

25 The effect of this change in case of a scene change in the middle of a GOP is that a scene change P frame might obtain more bits which improves its quality. However, due to VBV fullness and/or the reduced bit budget, most probably the next regular I frame will not get as many bits as it should,
30 hereby decreasing the quality of the whole next GOP. Therefore, preferably, the "constant bit budget per GOP" notion is used for CBR applications.

A minimum bit budget is needed for each frame to be able to
35 encode at least the overhead information. This is most important for B frames that tend to be least complex, therefore getting allocated very few bits. CBR rate control may use fixed minimum bit budgets, however, an estimation of the

necessary overhead bit budget could also be made based on the past frames.

The maximum number of bits that can be allocated to a frame (usually an I frame) is bound by the status of the VBV. No
5 more than `VBV_buffer_size` bits can be consumed by a single frame, given an initially empty encoder buffer.

2) *buffer control (local control):*

For each individual frame the bit production is controlled
10 to be within some range of the allocated target number of bits, using a virtual buffer concept, that corresponds to a P-controller in control theory. This is depicted in Fig. 5. The virtual buffer VBU_C is filled from the difference e_m between the bits b_m generated by each unit (macroblock) in the
15 MPEG2 encoder MEN , and from the portion of the target for this unit, $t_m = T_C / M$, where M is the number of units per frame.

Independent virtual buffers VBU_C with a possibly different size V_{CO} are used for each frame coding type $c = i, p, b$,
20 since difficulties in matching the target for one frame type should not propagate to other frame types. The status d_m of the virtual buffer VBU_C at the end of a frame is propagated as d_0 to the next frame of the same coding type:

$$d_m = d_0 + \sum (b_m - t_m) \quad (6)$$

25

For each unit m a quantiser step size q_m is computed in calculating means QC from the fullness of this virtual buffer d_m relative to its size V_{CO} .

The so-called "non-linear quantiser" table, see table 7-6 in
30 ISO/IEC 13818-2, (which does not refer to non-linear quantisation) is used to obtain a sufficiently progressive non-linear mapping of the available 31 codewords for `quantiser_scale_code` to actual quantiser step sizes q_m . `quantiser_scale_code` can be simply set to $32 * d_m / V_{CO}$. The
35 very coarse quantisation available with this table can be used to deal with "panic" situations when the buffer is close to full.

The size of the virtual buffer, V_{CO} , which in control theory is called "reaction" parameter of the P-controller, determines the tightness of control. It can be made very large (even larger than the VBV) if it is acceptable that the number of bits generated deviates much from the target.

A large virtual buffer can be used, e.g., for P frames, since it is not known a priori whether a scene change will occur in the current GOP. In case of scene change the bit production can be unpredictably high. However, this will result in impaired quality only in such cases where the virtual buffer is filled to such extent that the quantiser step size is drastically increased.

Advantageously, the reaction to an unpredicted high bit production is delayed as much as possible, while an unpredicted low bit production should result in immediate reduction of the quantiser step size. This can be realised by different reaction parameters V_{CO} , Vd_{CO} , (i.e. virtual buffer size), which e.g. depend on the relation between the virtual buffer fullness d_m when coding unit m and the initial fullness d_0 at the start of a frame, using:

if $d_m > d_0$

$$\text{quantiser_scale_code} = 32 * d_m / V_{CO}, \quad (7)$$

else

$$\text{quantiser_scale_code} = 32 * (d_0 / V_{CO} - (d_0 - d_n) / Vd_{CO}) .$$

25

Vd_{CO} , which is the reaction when d_m is going down, should be small compared to V_{CO} . q_m is derived again by a look-up in table 7-6 of ISO/IEC 13818-2.

The status of the VBV should be monitored in addition to the control based on the virtual buffers, especially if control is "loose", i.e. the virtual buffers are big. While the target for a frame as well as the target for a whole GOP may be exceeded, the VBV, representing the decoder physical buffer, may never under- or overflow.

Furthermore MPEG disallows frequent occurrence of units (macroblocks) that exceed a certain number of bits (ISO/IEC 13818-2, table 8-6). This has to be monitored and controlled as well.

3) *content adaptive quantisation:*

To reflect the varying local complexity of different parts of an image, a local complexity measure for each unit can be
5 computed. Currently this is derived from the AC energy of the luminance blocks of the unit.

The complexity factor obtained is used to modify the previously computed quantiser step size to some extent, e.g. by a factor in the range 0.5 to 2.0. Only this final quantiser
10 step size information (coded as `quantiser_scale_code`) is transmitted in the bitstream each time it is different from that for the previous unit (macroblock). The aim is to distribute bits in such a way that the subjective quality within the frame is homogenous. Alternative schemes exploiting
15 the properties of the human visual system to that end can be applied here.

Preferably, control level 3) is disabled in case of coarse quantisation since otherwise no strict control of bit generation is possible.

20

Advantageously, if the bit allocation in level 1) is successful, level 2) should maintain a mostly constant virtual buffer status, i.e. a constant quantiser step size, throughout a frame.

25 However, the bit allocation can fail and/or the complexity can be distributed very inhomogeneously within the frame, so that in practice this will never be completely true.

Another reason for sub-optimum performance of the control scheme is the fact that the complexity values computed in
30 step 1) are not constant for a given image, but they depend on the quantisation step size in a way that cannot easily be modelled. This is depicted in Fig. 6, showing the complexity X over quantiser step size Q for I frames of 12 different sequences. When coding natural picture sequences one can observe
35 some degree of oscillation in bit allocation for subsequent P frames, although the scene was completely temporally homogeneous. Advantageously, this behaviour can be

avoided if a complexity measure is used that is independent of the applied quantiser step size.

In VBR applications the following additional considerations must be made, beginning with the encoder and decoder buffers.

As mentioned above, physical buffers are advantageous even in the VBR case. The reason for this is the huge amount of bits produced by I frames compared to other frame types. When encoding standard TV pictures (CCIR 601 resolution) at a reasonable quality with CBR, e.g. at 5Mbit/s, a typical instantaneous data rate for an I frame can be more than 15Mbit/s, with "instantaneous data rate" defined as (bits generated by a frame) / (one frame period).

As long as the peak data rate of the storage device is below this value, a buffer is still necessary to be able to achieve higher quality with VBR than with CBR coding. The VBV_buffer_size of 1.75Mbit for Main Profile @ Main Level will limit the peak instantaneous data rate to e.g. a more than sufficient 45Mbit/s rate assuming an initially empty buffer.

Advantageously, the VBR output of the encoder buffer and the VBR input of the decoder buffer can be modelled as leaky buckets. Data always leaks at the peak rate of the channel. It leaks out of the encoder buffer as long as data is present in it, while it leaks into the decoder buffer as long as it is not full.

For control purposes the physical buffer status can be monitored once per frame (field) period only. However, this means that a buffer portion of the size $[(\text{peak data rate}) / (\text{frame period})]$ is needed to cope with a possible unequal bit production during the frame period. This further limits the peak instantaneous data rate. Advantageously, buffer control on a unit by unit (macroblock by macroblock) basis can be used to avoid this situation.

A VBR control should reach the following goals:

As postulated at the beginning a VBR encoder control should be more targeted to equalising the quality over the whole duration of a recording on the storage medium. Especially,

bits should not be spent unless an additional (visible) gain in quality can be expected. From the rate control point of view, two scenarios can be distinguished.

5 *Scenario 1)* Fit a maximum duration of video on a storage medium of given capacity:

A sufficient quality can be selected by the application designer by setting the quantiser step size from control step 2) to an appropriate value. The content adaptive quantisation of step 3) should still be done, since it addresses the subjective quality harmonisation within each frame. In fact, improvements in this area are possible if vision models are used that better reflect the artefact visibility by a human observer.

15 Rate control is now necessary only to avoid overflow of the encoder buffer. Underflow will not occur in a VBR application, since the variable channel data rate is allowed to be zero temporarily.

20 *Scenario 1a)* Guaranteed minimum duration of video:

Using a rate control as described in *scenario 2)* below, it would furthermore be possible to guarantee a minimum recording duration on the medium. Depending on the complexity of the video, the recording duration can also be higher than
25 this minimum.

Scenario 2) Fit a video of given duration on a medium of given capacity:

Again, it is assumed that there is no a priori analysis of the complexity distribution throughout the video material. As long as there is no complexity measure available that is independent from the quantiser step size and that can be derived from variables that are readily available from a reasonably low cost encoder, control solutions to equalise the video quality throughout its duration have to use some heuristics and will not be optimum.

35 The basic idea for a VBR control approach is to have a very loose control with varying bit rate at the beginning, while

control becomes tighter when the end of the capacity of the storage medium is approached or when the remaining duration of the picture material to be coded is such that a pre-selected minimum bit rate can not be guaranteed throughout this remaining duration.

It should be noted, however, that this approach privileges the beginning of a recording, that can now exhibit constant quality, while a constant rate with possibly lower quality is enforced toward the end.

Advantageously, this disadvantage can be remedied to some extent if the constant bit rate R_e that is used toward the end of the recording is selected to be higher than the average bit rate R_{avg} for the whole recording. That average bit rate can be computed as

$$R_{avg} = B / T \quad (8)$$

with B being the total storage medium capacity and T the video material duration.

Advantageously, this bit rate R_e is chosen such that most video content at the end exhibits acceptable quality while the quality for the first part of the recording is still better than in case of CBR coding of the whole recording.

So, from the above, for each kind of recording the unknown variables are the quantiser step size at the start of the encoding and the constant bit rate R_e toward the end. Unfortunately, it is not easily possible to find a suitable quantiser step size to start with, since without knowledge about the complexity of a video it is difficult to estimate its bit production at a given quantiser step size.

Furthermore, it is somewhat messy to build a control scheme that monitors the physical buffer fullness at all times and allows the transition from constant quantiser to constant rate operation. This transition depends on the amount of bits produced until a point in time t as well as on the duration that remains to be encoded. Early production of an unproportionately high amount of bits as well as a short remaining duration are indicators for the need of tight rate control.

Therefore, the following modified rate control scheme is proposed:

It is preferable to keep the bit rate controlled during the whole recording. By having a very loose control (= very big virtual buffers) and by removing the constant bit budget $B_G(g)$ per GOP at the beginning it is possible to allow rather large variations in instantaneous bit rate (i.e. a quasi-constant quantiser step size) so that at least scene changes and difficult scenes of a duration of a couple of seconds will benefit from this loose control.

For this purpose it is necessary to define the behaviour change of the rate control scheme over time.

First, reasonable values for the average bit rate at the beginning and at the end of the recording need to be defined. Taking R_{avg} as the average bit rate for this recording, computed as in equation (8), it is advantageous to have for instance:

$$R_{start} = 0.95 * R_{avg} \quad (9a)$$

$$R_{end} = 1.5 * R_{avg}, \quad (9b)$$

considering that 0.95 times the average bit rate would in the worst case lead to a negligible loss if the whole picture sequence has a constant complexity over time, while 1.5 times the average bit rate at the end is sufficient to properly code most worst case picture content if it happens to occur just at the end.

Over the whole time (with a linear transition from R_{start} to R_{end}) R_{avg} can be regarded as composed of

$$R_{avg} = R_{start} * \tau_1 + 0.5 * (R_{start} + R_{end}) * \tau_2 + R_{end} * \tau_3 \quad (10a)$$

with the time periods τ_1 , τ_2 , and τ_3 normalised to be

$$\tau_1 + \tau_2 + \tau_3 = 1 \text{ (total time of storage medium)} \quad (10b)$$

With the above assumptions it is necessary to select one more parameter. Setting τ_3 to 0.01 reflects the fact, that precise control of the overall bit production can be re-established in a very short time. Given e.g. one hour video duration T this corresponds to $\tau_3 * T = 36$ seconds. τ_3 can be regarded as an overall bit number adaptation period.

Solving the equations (9a) to (10b) yields

$\tau_1 = 0.79$ and $\tau_2 = 0.20$.

With these figures loose control will occur during about 79% of the recording time while the transition phase takes about 20% of the total time. Other transition characteristics can
 5 be implemented that increase the percentage of time with loose control even more.

The time variant parameters of the rate control can now be described using

$$\alpha = \begin{cases} 0 & , \tau < \tau_1 \\ (\tau - \tau_1) / (\tau_2 - \tau_1) & , \tau_1 \leq \tau \leq \tau_2 \\ 1 & , \tau > \tau_2 \end{cases} \quad (11)$$

15 Other transition characteristics for α can be implemented between time instants τ_1 and τ_2 .

The bit rate used for step 1) of the rate control now is

$$R(\tau) = (1-\alpha)*R_{\text{start}} + \alpha*R_{\text{end}} \quad (12)$$

20 The virtual buffer sizes V_{CO} , $c = i, p, b$, are advantageously modified to be

$$V_C(\tau) = ((1-\alpha)*V_{\text{huge}} + \alpha)*V_{CO} \quad (13)$$

For example, an increase in size of $V_{\text{huge}} = 100$ can be used.

25 These huge virtual buffers corresponding to a very slow reaction are intentional for short time intervals of complex picture material. However, it is not desirable that a non-complex part of the video following a long complex part could now be coded with a very coarse quantiser step size.

30 It is therefore necessary to use the above mentioned idea of a quicker reaction parameter in case the bit production (= the virtual buffer status) decreases more than predicted, i.e. falls below the target. This parameter, Vd_C , might also be time variant according to

$$35 Vd_C(\tau) = ((1-\alpha)*Vd_{\text{huge}} + \alpha)*Vd_{CO} , \quad (14)$$

but as initial guess $Vd_{\text{huge}} = 1$ is proposed, since during the whole duration a fast reaction is desirable in this case.

Advantageously, the re-filling of the bit budget $B_F(n)$ is now carried out not only once per GOP.

Refill per frame n:

$$B_F(n) = B_F(n-1) + (1-\alpha) * R(\tau) / (\text{frame rate})$$

5

Refill per GOP g:

$$B_F(n=0) = B_G(g) =$$

$$\alpha * R(\tau) * (\text{frames per GOP}) / (\text{frame rate}) + B_G(g-1)$$

10 Apart from the emptying of the encoder buffer and, hence, the VBV as a leaky bucket, as described before, these can be the only changes that need to be made to the CBR rate control as described in the first part of the specification.

15 In principle, the inventive method of encoding digital video data is suited for storage on memory or recording means having a given data storage capacity and allowing a variable instantaneous storage bit rate, whereby

- for a first part of said storage capacity the data is encoded using a slightly less than average bit rate and a significantly more loose than average bit rate control;
- for a second part of said storage capacity the data is encoded using a higher than average bit rate and a tight bit rate control.

25

In principle, the inventive method is suited for decoding digital video data stored on memory or recording means having a given data storage capacity and allowing a variable instantaneous reading bit rate into decoding buffer means, whereby

30

- during a first part of said storage capacity the data is decoded using a slightly less than average decoder buffer means input bit rate and significantly higher than average allowable buffer filling level variations;

35

- during a second part of said storage capacity the data is decoded using a higher than average decoder buffer means input bit rate and less than average allowable buffer filling level variations.

Advantageous additional embodiments of the inventive methods are resulting from the respective dependent claims.

In principle the inventive apparatus is suited for encoding
5 digital video data for storage on memory or recording means
having a given data storage capacity and allowing a variable
instantaneous storage bit rate, using an encoding loop in-
cluding discrete cosine transform means, quantiser means,
inverse quantiser means, inverse discrete cosine transform
10 means, picture store means, and entropy encoding means de-
livering the encoded output signal and being connected to
the output of said quantiser means, wherein said quantiser
means, said inverse quantiser means, and said entropy encod-
ing means are controlled in the following way:

- 15 - for a first part of said storage capacity the data is en-
coded using a slightly less than average bit rate and a sig-
nificantly more loose than average bit rate control;
- for a second part of said storage capacity the data is
encoded using a higher than average bit rate and a tight bit
20 rate control.

In principle the inventive apparatus is suited for decoding
digital video data which are stored on memory or recording
means having a given data storage capacity and allowing a
25 variable instantaneous reading bit rate into decoding buffer
means, using a chain of entropy decoding means, inverse
quantiser means, inverse discrete cosine transform means,
and adding means delivering the decoded output signal which
is also fed to picture store means the output signal of
30 which is provided to a second input of said adding means,
wherein said decoding buffer means are controlled in the
following way:

- during a first part of said storage capacity the data is
decoded using a slightly less than average decoder buffer
35 means input bit rate and significantly higher than average
allowable buffer filling level variations;
- during a second part of said storage capacity the data is
decoded using a higher than average decoder buffer means in-

put bit rate and less than average allowable buffer filling level variations.

Advantageous additional embodiments of the inventive apparatuses are resulting from the respective dependent claims.

In principle, the inventive digital video signal is suited for storage on memory or recording means having a given data storage capacity and allowing a variable instantaneous storage bit rate, whereby

- during a first part of said storage capacity the signal is encoded using a slightly less than average bit rate and a significantly more loose than average bit rate control;
- during a second part of said storage capacity the signal is encoded using a higher than average bit rate and a tight bit rate control.

Preferably, the inventive digital video signal is an MPEG2 or MPEG1 or H261 encoded video signal.

The inventive storage medium, in particular an optical disc, contains or has recorded on it an inventive digital video signal.

25 Drawings

Preferred embodiments of the invention are described with reference to the accompanying drawings, which show in:

- Fig. 1 constant bit rate system;
- 30 Fig. 2 variable bit rate system;
- Fig. 3 basic block diagram of MPEG encoder;
- Fig. 4 basic block diagram of MPEG decoder;
- Fig. 5 structure of a control loop;
- Fig. 6 example functions for complexity over quantiser
- 35 step size.

Preferred embodiments

In a CBR and in a VBR application the MPEG2 encoder MENC produces variable bit rate data VBRD which is intermediately stored in the encoder buffer ENCB. The filling level of this buffer can be used to control the coding process in MENC. At receiver side variable bit rate data VBRD which is intermediately stored in the decoder buffer DECB are fed to an MPEG2 decoder MDEC. The reading of that data from DECB is controlled by MDEC.

In Fig. 1 the encoder buffer ENCB delivers a constant bit rate data stream CBR to the decoder buffer DECB. In Fig. 2, however, the encoder buffer ENCB delivers a variable bit rate data stream VBR to the decoder buffer DECB.

In Fig. 3 the encoder video data input signal IE includes macroblock data to be encoded. In case of intraframe data a subtractor SUB simply passes the data via discrete cosine transform computing means DCT and quantising means Q to entropy encoding means ECOD which may include ENCB and which deliver the encoder video data output signal OE.

In case of interframe data subtractor SUB subtracts predicted macroblock data PMD from the input signal and passes the difference data via discrete cosine transform computing means DCT and quantising means Q to entropy encoding means ECOD. The output signal of Q is also fed to inverse quantising means Q_E^{-1} the output signal of which passes through inverse discrete cosine transform computing means DCT_E^{-1} to adder ADDE in the form of reconstructed macroblock difference data RMDD. The output signal of ADDE is intermediately stored in frame store and motion compensation means FS_MC_E which also perform motion compensation on reconstructed macroblock data and which deliver such predicted macroblock data PMD to SUB and to the other input of adder ADDE.

Quantising means Q, inverse quantising means Q_E^{-1} , and ECOD are controlled by the filling level of encoder buffer ENCB in the inventive way described above. It is also possible that FS_MC_E does not perform motion compensation.

The variable bit rate output to the storage medium can be done using the maximum possible bit rate while there is data available from the encoder buffer, and can be suspended else.

5

In Fig. 4 the decoder video data input signal ID passes through entropy decoding means EDEC which may include DECB, inverse quantising means Q_D^{-1} , and inverse discrete cosine transform computing means DCT_D^{-1} to an adder ADDD which delivers the decoder video data output signal OD. The output signal of ADDD is fed to frame store and motion compensation means FS_MC_D which also perform motion compensation on reconstructed macroblock data and which in case of interframe macroblock data deliver such predicted macroblock data PMD to the other input of adder ADDE. In case of intraframe macroblock data the adder ADDD simply passes the output signal of DCT_D^{-1} .

15
Inverse quantising means Q_D^{-1} and EDEC are controlled according to the kind of control for Q_E^{-1} and ECOD. Normally, in motion compensation means FS_MC_D the same motion vector information is used as in motion compensation means FS_MC_E. It is also possible that FS_MC_D does not perform motion compensation.

20
In order to handle situations of high bit rate demand, e.g. in case of scene changes and complex scene content, the decoder buffer DECB is filled from the storage medium with preferably the maximum possible bit rate. This can be done generally in case DECB is not full whereby no data from the storage medium is stored into DECB if DECB is full. As an alternative, DECB can be filled with a bit rate which corresponds to the respective bit rate when storing data on the memory or recording means. In either case the reading bit rate out of DECB corresponds to that when encoding, i.e. the allowed and sometimes really occurring average buffer filling level variations are greater in the first part ($\approx 80\%$) of the total capacity and are less in the last part ($\approx 20\%$) of the total capacity. "Average allowable buffer filling level variations" means the variation over a length of some GOPs.

The invention can be used in any means like DVD, other optical or magneto-optical or ferro-optical discs, electronic or optical RAM or ROM, and magnetic tape systems which use a
5 given capacity for storing video data.

The invention is not limited to MPEG2 encoders and decoders, but can also be used with MPEG1 (ISO/IEC 11172-2), H261 (ISO/IEC), and other coding and decoding methods in e.g. standard TV, HDTV, and videophone applications.

Claims

1. Method of encoding digital video data for storage on memory or recording means having a given data storage capacity and allowing a variable instantaneous storage bit rate (VBR), **characterised** in that
 - for a first part of said storage capacity the data is encoded (MENC; Q, Q_E^{-1} , ECOD) using a slightly less than average bit rate and a significantly more loose than average bit rate control;
 - for a second part of said storage capacity the data is encoded (MENC; Q, Q_E^{-1} , ECOD) using a higher than average bit rate and a tight bit rate control.

2. Method of decoding digital video data stored on memory or recording means having a given data storage capacity and allowing a variable instantaneous reading bit rate (VBR) into decoding buffer means, **characterised** in that
 - during a first part of said storage capacity the data is decoded (MDEC) using a slightly less than average decoder buffer means (DECB) input bit rate and significantly higher than average allowable buffer filling level variations;
 - during a second part of said storage capacity the data is decoded (MDEC) using a higher than average decoder buffer means (DECB) input bit rate and less than average allowable buffer filling level variations.

3. Apparatus for encoding digital video data for storage on memory or recording means having a given data storage capacity and allowing a variable instantaneous storage bit rate (VBR), using an encoding loop including discrete cosine transform means (DCT), quantiser means (Q), inverse quantiser means (Q_E^{-1}), inverse discrete cosine transform means (DCT_E^{-1}), picture store means (FS_MC_E), and entropy encoding means (ECOD) delivering the encoded output signal (OE) and being connected to the output of said quantiser means, **characterised** in that said quan-

tiser means (Q), said inverse quantiser means (Q_E^{-1}), and said entropy encoding means (ECOD) are controlled in the following way:

- for a first part of said storage capacity the data is encoded using a slightly less than average bit rate and a significantly more loose than average bit rate control;
- for a second part of said storage capacity the data is encoded using a higher than average bit rate and a tight bit rate control.

4. Apparatus for decoding digital video data which are stored on memory or recording means having a given data storage capacity and allowing a variable instantaneous reading bit rate (VBR) into decoding buffer means (DECB), using a chain of entropy decoding means (EDEC), inverse quantiser means (Q_D^{-1}), inverse discrete cosine transform means (DCT_D^{-1}), and adding means (ADDD) delivering the decoded output signal (OD) which is also fed to picture store means (FS_MC_D) the output signal of which is provided to a second input of said adding means, **characterised** in that said decoding buffer means (DECB) are controlled in the following way:

- during a first part of said storage capacity the data is decoded (MDEC) using a slightly less than average decoder buffer means (DECB) input bit rate and significantly higher than average allowable buffer filling level variations;
- during a second part of said storage capacity the data is decoded (MDEC) using a higher than average decoder buffer means (DECB) input bit rate and less than average allowable buffer filling level variations.

5. Digital video signal which is suited for storage on memory or recording means having a given data storage capacity and allowing a variable instantaneous storage bit rate, whereby

- during a first part of said storage capacity the signal is encoded using a slightly less than average bit rate and a significantly more loose than average bit rate control;
- 5 - during a second part of said storage capacity the signal is encoded using a higher than average bit rate and a tight bit rate control.
- 6. Signal according to claim 5, which is an MPEG2 or MPEG1
10 or H261 encoded video signal.
- 7. Storage medium, in particular an optical disc, containing or having recorded on it a signal according to claims 5 or 6.
- 15 8. Method, apparatus, signal, or storage medium according to any of claims 1 to 7, wherein in said first part of said storage capacity said encoding and decoding, respectively, is carried out using an average data rate
20 which is about 95% of that basic average data rate which would be allowed for said memory or storage means if no separation into said first and second part would take place, and wherein in said second part of said storage capacity said encoding and decoding, respectively, is
25 carried out using an average data rate which is about 150% of that basic average data rate.
- 9. Method, apparatus, signal, or storage medium according to any of claims 1 to 8, wherein said first part of said
30 storage capacity occupies about 80% of the total available storage capacity for said digital video data and wherein said second part of said storage capacity occupies about 20% of said total available storage capacity.
- 35 10. Method, apparatus, signal, or storage medium according to any of claims 1 to 9, wherein between said first part and said second part of said storage capacity there is a further part in which

for encoding the average bit rate and bit rate control
and

for decoding the average decoder buffer means (DECB) in-
put bit rate and the average allowable buffer filling

5 level variations

are changed to form a smooth transition.

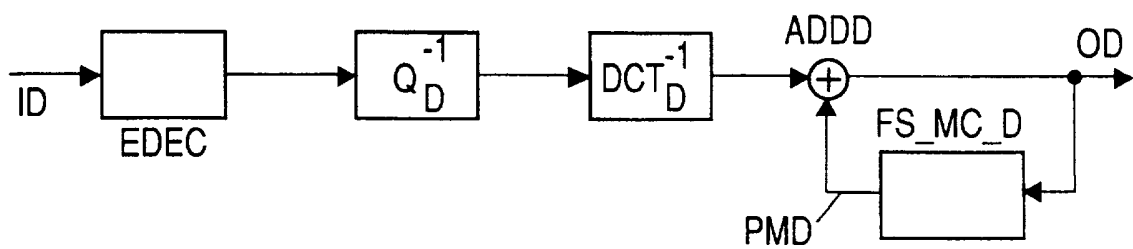
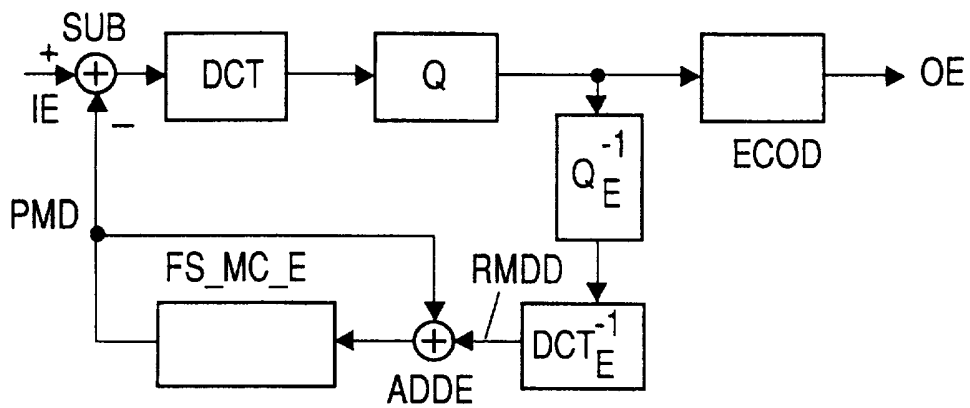
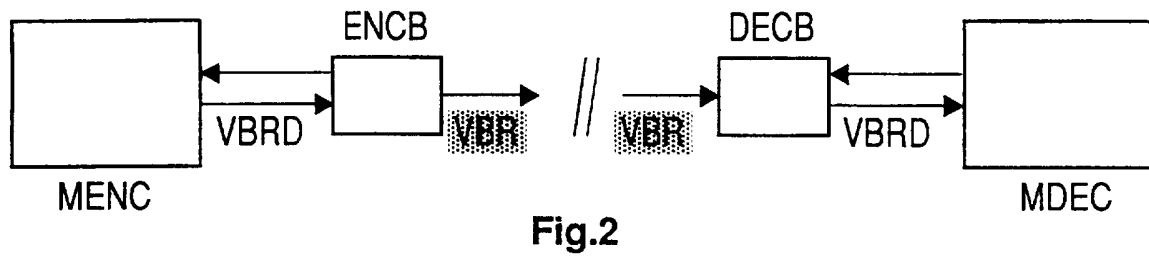
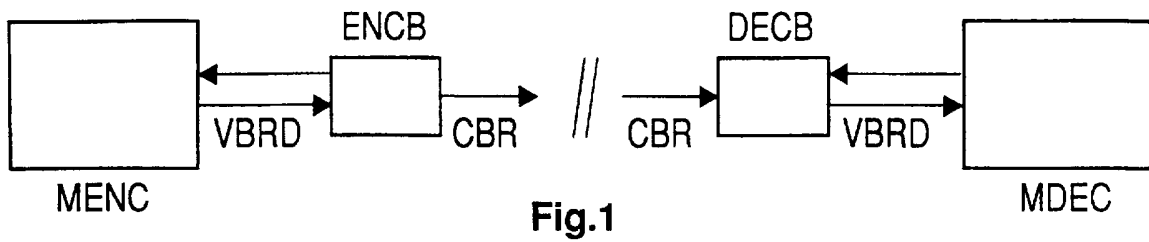

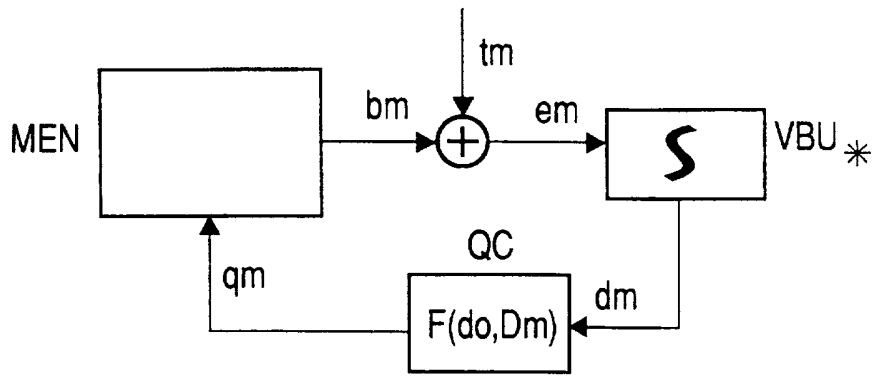

Fig.5

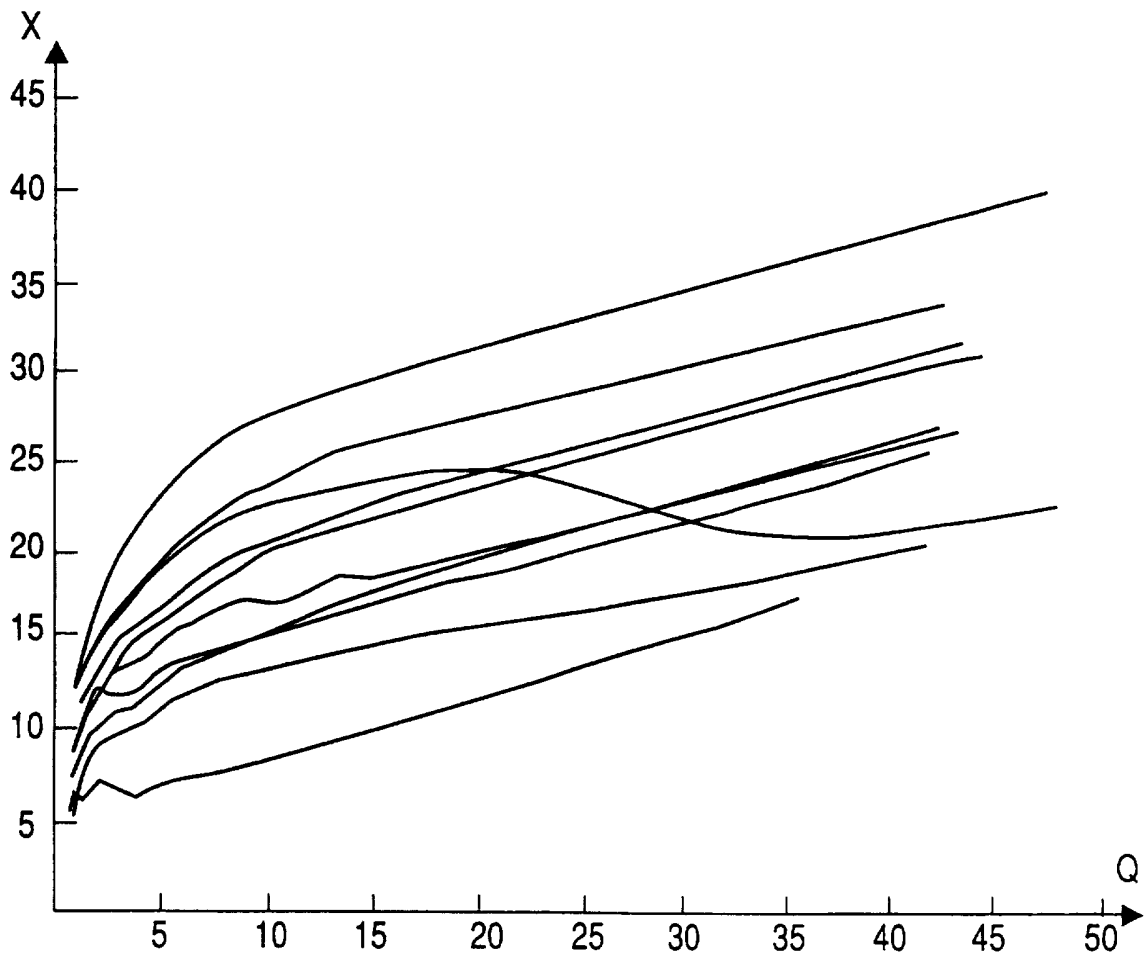

Fig.6

INTERNATIONAL SEARCH REPORT

International Application No
PCT/EP 97/00863

A. CLASSIFICATION OF SUBJECT MATTER IPC 6 H04N7/50				
According to International Patent Classification (IPC) or to both national classification and IPC				
B. FIELDS SEARCHED Minimum documentation searched (classification system followed by classification symbols) IPC 6 H04N				
Documentation searched other than minimum documentation to the extent that such documents are included in the fields searched				
Electronic data base consulted during the international search (name of data base and, where practical, search terms used)				
C. DOCUMENTS CONSIDERED TO BE RELEVANT				
Category *	Citation of document, with indication, where appropriate, of the relevant passages	Relevant to claim No.		
A	EP 0 595 268 A (VICTOR COMPANY OF JAPAN) 4 May 1994 see column 1, line 29 - column 2, line 17 see column 7, line 53 - column 8, line 17 see column 16, line 26 - column 17, line 12 see column 19, line 25 - line 47 see claim 3 see figures 4,7	1-6,8,9		
A	--- EP 0 664 651 A (HITACHI LTD) 26 July 1995 see column 4, line 8 - line 41 see column 6, line 18 - column 7, line 10 see column 10, line 40 - line 51 see column 11, line 14 - line 24 see claims 9-11,17-19 --- -/--	1-7		
<input checked="" type="checkbox"/> Further documents are listed in the continuation of box C.				
<input checked="" type="checkbox"/> Patent family members are listed in annex.				
* Special categories of cited documents :				
<table style="width: 100%; border: none;"> <tr> <td style="width: 50%; border: none; vertical-align: top;"> *A* document defining the general state of the art which is not considered to be of particular relevance *E* earlier document but published on or after the international filing date *L* document which may throw doubts on priority claim(s) or which is cited to establish the publication date of another citation or other special reason (as specified) *O* document referring to an oral disclosure, use, exhibition or other means *P* document published prior to the international filing date but later than the priority date claimed </td> <td style="width: 50%; border: none; vertical-align: top;"> *T* later document published after the international filing date or priority date and not in conflict with the application but cited to understand the principle or theory underlying the invention *X* document of particular relevance; the claimed invention cannot be considered novel or cannot be considered to involve an inventive step when the document is taken alone *Y* document of particular relevance; the claimed invention cannot be considered to involve an inventive step when the document is combined with one or more other such documents, such combination being obvious to a person skilled in the art. *&* document member of the same patent family </td> </tr> </table>			*A* document defining the general state of the art which is not considered to be of particular relevance *E* earlier document but published on or after the international filing date *L* document which may throw doubts on priority claim(s) or which is cited to establish the publication date of another citation or other special reason (as specified) *O* document referring to an oral disclosure, use, exhibition or other means *P* document published prior to the international filing date but later than the priority date claimed	*T* later document published after the international filing date or priority date and not in conflict with the application but cited to understand the principle or theory underlying the invention *X* document of particular relevance; the claimed invention cannot be considered novel or cannot be considered to involve an inventive step when the document is taken alone *Y* document of particular relevance; the claimed invention cannot be considered to involve an inventive step when the document is combined with one or more other such documents, such combination being obvious to a person skilled in the art. *&* document member of the same patent family
A document defining the general state of the art which is not considered to be of particular relevance *E* earlier document but published on or after the international filing date *L* document which may throw doubts on priority claim(s) or which is cited to establish the publication date of another citation or other special reason (as specified) *O* document referring to an oral disclosure, use, exhibition or other means *P* document published prior to the international filing date but later than the priority date claimed	*T* later document published after the international filing date or priority date and not in conflict with the application but cited to understand the principle or theory underlying the invention *X* document of particular relevance; the claimed invention cannot be considered novel or cannot be considered to involve an inventive step when the document is taken alone *Y* document of particular relevance; the claimed invention cannot be considered to involve an inventive step when the document is combined with one or more other such documents, such combination being obvious to a person skilled in the art. *&* document member of the same patent family			
Date of the actual completion of the international search	Date of mailing of the international search report			
4 June 1997	17.06.97			
Name and mailing address of the ISA European Patent Office, P.B. 5818 Patentlaan 2 NL - 2280 HV Rijswijk Tel. (+ 31-70) 340-2040, Tx. 31 651 epo nl, Fax (+ 31-70) 340-3016	Authorized officer Dippel, U			

INTERNATIONAL SEARCH REPORT

International Application No

PCT/EP 97/00863

C.(Continuation) DOCUMENTS CONSIDERED TO BE RELEVANT		
Category *	Citation of document, with indication, where appropriate, of the relevant passages	Relevant to claim No.
A	US 5 134 476 A (ARAVIND RANGARAJAN ET AL) 28 July 1992 see column 2, line 6 - line 24 see column 4, line 60 - column 5, line 17 see column 6, line 36 - line 64 see figure 3 ---	1-6
A	EP 0 637 891 A (SONY UK LTD) 8 February 1995 see column 1, line 38 - column 3, line 11 see column 4, line 53 - column 5, line 9 see column 6, line 31 - line 41 see column 7, line 36 - column 8, line 1 ---	1-5
A	EP 0 670 663 A (PHILIPS ELECTRONIQUE LAB ;PHILIPS ELECTRONICS NV (NL)) 6 September 1995 see page 2, line 36 - line 54 -----	5,6,8-10

INTERNATIONAL SEARCH REPORT

information on patent family members

International Application No

PCT/EP 97/00863

Patent document cited in search report	Publication date	Patent family member(s)	Publication date
EP 0595268 A	04-05-94	JP 6141298 A JP 6165125 A	20-05-94 10-06-94

EP 0664651 A	26-07-95	JP 7212710 A	11-08-95

US 5134476 A	28-07-92	NONE	

EP 0637891 A	08-02-95	GB 2280566 A JP 7093891 A US 5612788 A	01-02-95 07-04-95 18-03-97

EP 0670663 A	06-09-95	FR 2717029 A JP 7284109 A	08-09-95 27-10-95
