



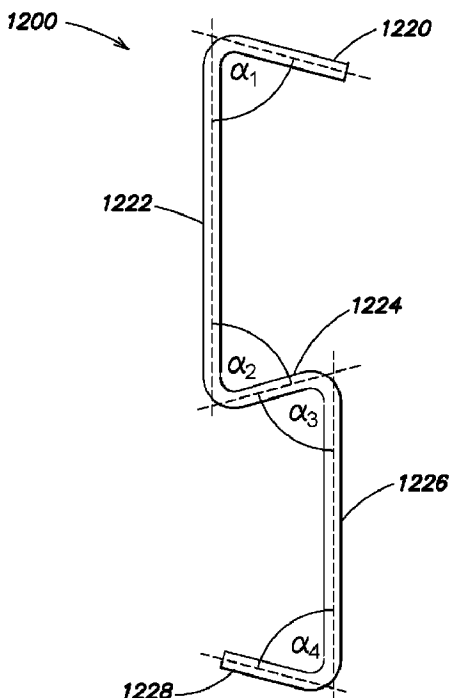
(12) **DEMANDE DE BREVET CANADIEN  
CANADIAN PATENT APPLICATION**

(13) **A1**

(86) Date de dépôt PCT/PCT Filing Date: 2019/10/02  
 (87) Date publication PCT/PCT Publication Date: 2020/04/09  
 (85) Entrée phase nationale/National Entry: 2021/03/31  
 (86) N° demande PCT/PCT Application No.: US 2019/054220  
 (87) N° publication PCT/PCT Publication No.: 2020/072592  
 (30) Priorités/Priorities: 2018/10/02 (US62/740,385);  
 2019/02/27 (US62/811,157)

(51) Cl.Int./Int.Cl. *F16M 13/02* (2006.01),  
*B42F 13/00* (2006.01), *F21S 8/02* (2006.01),  
*F21V 21/04* (2006.01), *F21V 21/14* (2006.01),  
*F21V 21/22* (2006.01)  
 (71) Demandeur/Applicant:  
 VER LIGHTING LLC, US  
 (72) Inventeurs/Inventors:  
 KOPITZKE, FREDERICK WILLIAM, US;  
 KHAZI, MOHAMMED ASLAM, US;  
 LOTFI, AMIR, US  
 (74) Agent: BORDEN LADNER GERVAIS LLP

(54) Titre : ENSEMBLE DE SUSPENSION DE BARRE AVEC BARRES TELESCOPIQUES CORRESPONDANTES  
 (54) Title: A BAR HANGER ASSEMBLY WITH MATING TELESCOPING BARS



**FIG. 7B**

(57) **Abrégé/Abstract:**

A bar hanger assembly is used to couple a housing to a support structure. The bar hanger assembly may include a bar hanger holder to mechanically couple the bar hanger assembly to the housing, such as a junction box, a can housing, or a frame. The bar

(57) **Abrégé(suite)/Abstract(continued):**

hanger holder may define a channel to mechanically guide and support a pair of bar hangers. The bar hangers may be mechanically coupled together in a telescoping manner such that the first bar hanger is slidably adjustable with respect to the second bar hanger. The bar hanger holder and each bar hanger may physically contact one another and, in some instances, generate a compressive force to substantially reduce unwanted play. Each bar hanger may include a bar hanger head to couple the bar hanger assembly to various types of support structures, such as a T-bar, a stud, a joist, or a frame.

(12) INTERNATIONAL APPLICATION PUBLISHED UNDER THE PATENT COOPERATION TREATY (PCT)

(19) World Intellectual Property  
Organization  
International Bureau(43) International Publication Date  
09 April 2020 (09.04.2020)(10) International Publication Number  
**WO 2020/072592 A1**

## (51) International Patent Classification:

*F16M 13/02* (2006.01)      *F21V 21/14* (2006.01)  
*F21S 8/02* (2006.01)      *B42F 13/00* (2006.01)  
*F21V 21/04* (2006.01)      *F21V 21/22* (2006.01)

## (21) International Application Number:

PCT/US2019/054220

## (22) International Filing Date:

02 October 2019 (02.10.2019)

## (25) Filing Language:

English

## (26) Publication Language:

English

## (30) Priority Data:

62/740,385      02 October 2018 (02.10.2018)      US  
 62/811,157      27 February 2019 (27.02.2019)      US

(71) Applicant: **VER LIGHTING LLC** [US/US]; 1118e. 223rd St., Carson, CA 90745 (US).

## (72) Inventors; and

(71) Applicants (for US only): **KOPITZKE, Frederick, William** [US/US]; 707 E. Ocean Blvd. Apt. 403, Long Beach, CA 90802 (US). **KHAZI, Mohammed, Aslam**; 2034 Dorchester Road, Apt 105, Troy, MI 48084 (US). **LOTFI, Amir** [US/US]; 1912 Ruhland Avenue, Unit B, Redondo Beach, CA 90278 (US).

(74) Agent: **TONG, Jonathan, K.**; Smith Baluch LLP, 376 Boylston St., Suite 401, Boston, MA 02116 (US).

(81) Designated States (unless otherwise indicated, for every kind of national protection available): AE, AG, AL, AM, AO, AT, AU, AZ, BA, BB, BG, BH, BN, BR, BW, BY, BZ, CA, CH, CL, CN, CO, CR, CU, CZ, DE, DJ, DK, DM, DO, DZ, EC, EE, EG, ES, FI, GB, GD, GE, GH, GM, GT, HN, HR, HU, ID, IL, IN, IR, IS, JO, JP, KE, KG, KH, KN, KP, KR, KW, KZ, LA, LC, LK, LR, LS, LU, LY, MA, MD, ME, MG, MK, MN, MW, MX, MY, MZ, NA, NG, NI, NO, NZ, OM, PA, PE, PG, PH, PL, PT, QA, RO, RS, RU, RW, SA, SC, SD, SE, SG, SK, SL, SM, ST, SV, SY, TH, TJ, TM, TN, TR, TT, TZ, UA, UG, US, UZ, VC, VN, ZA, ZM, ZW.

(84) Designated States (unless otherwise indicated, for every kind of regional protection available): ARIPO (BW, GH, GM, KE, LR, LS, MW, MZ, NA, RW, SD, SL, ST, SZ, TZ, UG, ZM, ZW), Eurasian (AM, AZ, BY, KG, KZ, RU, TJ, TM), European (AL, AT, BE, BG, CH, CY, CZ, DE, DK, EE, ES, FI, FR, GB, GR, HR, HU, IE, IS, IT, LT, LU, LV, MC, MK, MT, NL, NO, PL, PT, RO, RS, SE, SI, SK, SM, TR), OAPI (BF, BJ, CF, CG, CI, CM, GA, GN, GQ, GW, KM, ML, MR, NE, SN, TD, TG).

(54) Title: A BAR HANGER ASSEMBLY WITH MATING TELESCOPING BARS

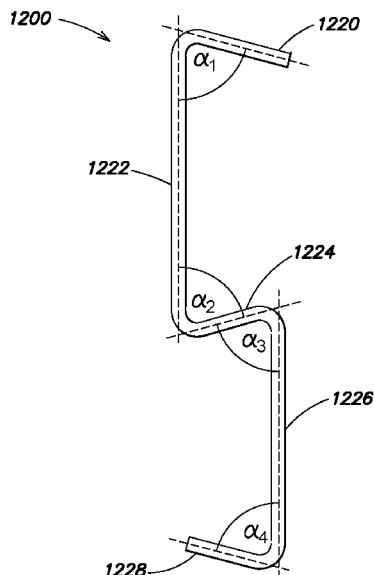


FIG. 7B

(57) Abstract: A bar hanger assembly is used to couple a housing to a support structure. The bar hanger assembly may include a bar hanger holder to mechanically couple the bar hanger assembly to the housing, such as a junction box, a can housing, or a frame. The bar hanger holder may define a channel to mechanically guide and support a pair of bar hangers. The bar hangers may be mechanically coupled together in a telescoping manner such that the first bar hanger is slidably adjustable with respect to the second bar hanger. The bar hanger holder and each bar hanger may physically contact one another and, in some instances, generate a compressive force to substantially reduce unwanted play. Each bar hanger may include a bar hanger head to couple the bar hanger assembly to various types of support structures, such as a T-bar, a stud, a joist, or a frame.



WO 2020/072592 A1

**WO 2020/072592 A1** 

---

**Declarations under Rule 4.17:**

- *as to applicant's entitlement to apply for and be granted a patent (Rule 4.17(ii))*

**Published:**

- *with international search report (Art. 21(3))*
- *before the expiration of the time limit for amending the claims and to be republished in the event of receipt of amendments (Rule 48.2(h))*

## A BAR HANGER ASSEMBLY WITH MATING TELESCOPING BARS

### CROSS-REFERENCE TO RELATED PATENT APPLICATION(S)

[0001] The present application claims priority to U.S. provisional application serial no. 62/740,385, filed October 2, 2018, entitled “BAR HANGER ASSEMBLY WITH IDENTICAL MATING TELESCOPING BARS,” and U.S. provisional application serial no. 62/811,157, filed February 27, 2019, entitled “BAR HANGER ASSEMBLY WITH IDENTICAL MATING TELESCOPING BARS,” each of which applications is incorporated by reference herein in its entirety.

### BACKGROUND

[0002] Luminaires are commonly installed in a building (e.g., multifamily housing, commercial spaces, residential homes) by utilizing a bar hanger assembly to mechanically couple the luminaire to a support structure, such as wooden or metal joists, T-bar supports, and/or steel framing. A conventional bar hanger assembly is typically comprised of one or more bar hangers that each include a bar hanger head to provide a mechanical interface from which the luminaire can be coupled to the various support structures described above. A pair of bar hangers are often coupled to each other such that the respective bar hangers are slidably adjustable along one preferred direction. In order to traverse a gap separating adjacent support structures, the bar hangers are slidably adjusted until the bar hanger head of each bar hanger is in physical contact with the support structure. In this manner, the bar hanger assembly can accommodate multiple support structures with variable separation distances between the support structures.

### SUMMARY

[0003] The Inventors have recognized and appreciated that a bar hanger assembly readily provides users the flexibility to install a luminaire in various built environments, which may include different types of support structures in various arrangements. However, the Inventors have also recognized that previous bar hanger assemblies suffered from multiple limitations that hindered their ease of use, mechanical strength and stability, and manufacturability.

[0004] For example, previous bar hangers were typically shaped to allow one bar hanger to slide along a preferred direction with respect to another bar hanger while maintaining mechanical

engagement between the bar hangers. Said in another way, previous bar hangers were not readily separable when subjected to a force applied along a direction that is not aligned with the preferred direction for adjustment.

[0005] Although previous bar hangers were able to maintain engagement with one another, the bar hangers were often fitted together loosely, which resulted in unwanted play between the bar hangers (i.e., unwanted relative movement between the bar hangers along a direction different from the preferred direction for adjustment). This unwanted play was further amplified when extending the bar hangers to cover a larger gap between the support structures due to a reduction in the physical overlap between the bar hangers. The unwanted play may also be exacerbated by the use of lower tolerances during manufacture. A large amount of unwanted play increases the difficulty in aligning and positioning the luminaire during installation and/or adjustment since the luminaire is able to move along multiple axes of motion rather than only the desired axes for adjustment.

[0006] In another example, previous bar hangers were often formed by bending a sheet, which resulted in a bar hanger cross-section shaped as a series of connected segments where each segment forms a side and/or a wall of the bar hanger. In previous bar hangers, adjoining segments were typically bent by more than 90 degrees resulting in an offset angle between said adjoining segments that was less than 90 degrees. For instance, a conventional bar hanger often included a cross-section with a U-shaped portion formed from two segments. As an example, FIG. 1 shows a cross-section of a conventional pair of bar hangers from U.S. Patent No. 8,939,418. As shown, the bar hangers 202 and 204 each include a U-shaped portion (e.g., the top of bar hanger 204, the bottom of bar hanger 202) formed by bending a first segment with respect to a second segment adjoining the first segment about 180 degrees such that the resultant offset angle between the segments was about 0 degrees. The two sides and/or walls that are bent by an angle substantially greater than 90 degrees with a small bending radius is difficult to manufacture. Typically, the fabrication of such tightly bent features involves multiple manufacturing steps where the tools used for manufacture may be reconfigured and/or retooled between each step, thus increasing the time and cost of manufacture.

[0007] The present disclosure is thus directed towards various inventive implementations of a bar hanger assembly that provides substantially less undesirable play (and, as a result, greater

mechanical strength and stability) and greater ease of manufacture. In one aspect, the bar hanger assembly may include a pair of bar hangers, in which a first bar hanger (also referred to in the art as a “bar hanger”) of the pair is shaped to physically contact a second bar hanger of the pair at one or more locations along the bar hanger. The physical contact between the bar hangers may reduce unwanted play between an assembly of two bar hangers by substantially reducing or, in some instances, eliminating the gaps and/or spaces between the bar hangers. In other words, the bar hangers are physically unable to move along one or more undesirable directions due to a relatively tighter fitting between the bar hangers (e.g., as compared to prior art approaches for bar hanger assemblies).

**[0008]** In some implementations, the bar hanger may be dimensioned to mechanically interfere with another bar hanger after engagement. For example, the bar hangers may be specified to have a unilateral tolerance (a tolerance that allows variation along one direction) for manufacture that results in interference under normal operating conditions. The interference may, in turn, generate a compressive force that presses the bar hangers together to ensure contact is maintained, thereby reducing unwanted play between the bar hangers. The compressive force may be adjusted such that the bar hangers remain slidably adjustable. For example, even with a significant compressive force applied to the bar hangers, the coefficient of friction (static and kinetic) of the contact surfaces of the respective bar hangers may be reduced by coating at least a portion of these surfaces with a lubricant. In this manner, a significant compressive force may be applied between the bar hangers without preventing a user from being able to slidably adjust one bar hanger with respect to the other bar hanger.

**[0009]** In another aspect, the compressive force may generate a corresponding frictional force between the two bar hangers that reduces or, in some instances, eliminates unwanted sliding movement between the bar hangers. Unwanted sliding movement may arise, for example, during installation when a user adjusts the bar hangers to cover a desired gap. If the user inadvertently tilts the bar hanger assembly, the weight of one bar hanger may cause said bar hanger to slidably move with respect to the other bar hanger resulting in the user having to readjust the relative positions of the bar hangers. The frictional force between the bar hangers may thus be tailored to prevent such unintended sliding movement of the bar hangers. In some implementations, the frictional force may be sufficiently large to prevent the bar hangers from moving relative to one

another without human intervention.

**[0010]** In another aspect, the bar hanger may be shaped to have a section forming a recessed rail on one side and/or a protruding rail on the opposite side. For example, the bar hanger may have a U-shaped section formed from three segments (as opposed to the two segments used in the conventional bar hangers of FIG. 1). Thus, the recessed and protruding rails correspond to the interior and exterior, respectively, of the U-shaped section. The protruding rail of one bar hanger may thus fit into the recessed rail of another bar hanger. In some implementations, this type of fitting may reduce the form factor of the bar hangers without reducing the mechanical stiffness and/or rigidity of the bar hanger assembly. In some implementations, the bar hangers in the bar hanger assembly may also be substantially identical.

**[0011]** In another aspect, the bar hanger may have a cross-section that comprises a series of connected segments where each segment represents a side and/or a wall of the bar hanger. Unlike previous conventional bar hangers, adjoining segments in inventive implementations disclosed herein may be formed to have an offset angle that allows manufacture without having to retool and/or reconfigure the instruments/machinery used for manufacturing. For example, the offset angle between adjoining segments in bar hangers according to the present disclosure may be between about 45 degrees and about 90 degrees. This corresponds to the adjoining segments being bent by about 90 degrees to about 135 degrees during manufacture. In this manner, the bar hanger may be more easily fabricated using fewer manufacturing steps.

**[0012]** Each bar hanger may further include a bar hanger head to facilitate coupling of the bar hanger assembly to a support structure. The bar hanger head may include one or more attachment features to couple to various types of support structures including, but not limited to a joist, a stud, a T-bar, and a frame. In some implementations, the bar hanger assembly may include substantially similar bar hanger heads (e.g., mirror symmetric bar hanger heads) coupled to each bar hanger for greater ease of alignment and attachment.

**[0013]** The bar hanger assembly may also include a bar hanger holder to couple the bar hangers to a housing (e.g., a can housing, a junction box, a frame) to contain a light source (e.g., luminaire) and/or another functional device. The bar hanger holder may define a channel through which the bar hangers are slidably adjustable with respect to the bar hanger holder. The bar hanger holder



may also be shaped to physically contact the bar hangers so as to constrain unwanted play between the bar hangers and the bar hanger holder. Thus, principles similar to those described above relating to design of respective bar hangers of the bar hanger assembly may also be applied to the bar hanger holder. For example, the bar hanger holder may be dimensioned to mechanically interfere with the bar hangers, resulting in a compressive force being applied to the bar hangers that ensures contact is maintained as the bar hangers are slidably adjusted relative to each other and/or the bar hanger holder. In some implementations, the compressive force may also generate a frictional force that prevents unwanted sliding movement between the bar hangers and the bar hanger holder without human intervention. The bar hanger holder may also be formed by bending a sheet with adjoining segments having an offset angle between about 45 degrees and about 90 degrees.

**[0014]** The bar hanger holder may also enable the bar hanger assembly to be adjustable with respect to the housing along a second axis that is different (e.g., not parallel) to a first axis along which the bar hangers are slidably adjustable. For example, the bar hanger holder may include a slot. A fastener may be inserted through the slot to couple the bar hanger holder to the housing. The slot may thus define another axis to adjust the position of the bar hanger assembly and, hence, the housing, with respect to the support structure. For instance, the slot may be oriented substantially orthogonal relative to the first axis along which the bar hangers are slidably adjustable (e.g., to enable both horizontal and vertical adjustments to the housing during installation). In another example, the bar hanger holder may include a threaded stud that is inserted through an opening (e.g., a slot) on the housing.

**[0015]** In one example, a bar hanger includes a rod having a S-shaped cross-section. The cross-section is formed from a bottom segment, a first segment coupled to a first end of the bottom segment that is parallel to a first axis, a middle segment coupled to a first end of the first segment, a second segment coupled to a first end of the middle segment that is parallel to the first axis, and a top segment coupled to a first end of the second segment. The first and bottom segments define a first offset angle. The middle and first segments define a second offset angle. The second and middle segments define a third offset angle. The top and second segments define a fourth offset angle. The first, second, third, and fourth offset angles are between about 45 degrees and about 90 degrees.

**[0016]** In another example, a bar hanger assembly includes a first bar hanger and a second bar hanger coupled to the first bar hanger where (1) the second bar hanger is telescopically slidable with respect to the first bar hanger along an axis and (2) a portion of the second bar hanger contacts a portion of the first bar hanger such that a compressive force is generated between the first and second bar hangers. The compressive force substantially reduces movement of the second bar hanger with respect to the first bar hanger along a direction that is not parallel to the axis.

**[0017]** In another example, a bar hanger assembly includes a first bar hanger having a first cross-section comprising a first series of connected segments and a second bar hanger, coupled to the first bar hanger, having a second cross-section comprising a second series of connected segments. The second bar hanger is telescopically slidable with respect to the first bar hanger along an axis. Each pair of adjoining segments in the first and second series of connected segments defines an offset angle between about 45 degrees and about 90 degrees. A subset of the first series of connected segments contacts a subset of the second series of connected segments such that movement of the second bar hanger with respect to the first bar hanger along a direction not parallel to the axis is substantially constrained.

**[0018]** It should be appreciated that all combinations of the foregoing concepts and additional concepts discussed in greater detail below (provided such concepts are not mutually inconsistent) are contemplated as being part of the inventive subject matter disclosed herein. In particular, all combinations of claimed subject matter appearing at the end of this disclosure are contemplated as being part of the inventive subject matter disclosed herein. It should also be appreciated that terminology explicitly employed herein that also may appear in any disclosure incorporated by reference should be accorded a meaning most consistent with the particular concepts disclosed herein.

#### BRIEF DESCRIPTION OF DRAWINGS

**[0019]** The skilled artisan will understand that the drawings primarily are for illustrative purposes and are not intended to limit the scope of the inventive subject matter described herein. The drawings are not necessarily to scale; in some instances, various aspects of the inventive subject matter disclosed herein may be shown exaggerated or enlarged in the drawings to facilitate an understanding of different features. In the drawings, like reference characters generally refer to

like features (e.g., functionally similar and/or structurally similar elements).

[0020] FIG. 1 shows a cross-section of a conventional pair of bar hanger.

[0021] FIG. 2A is a top, front, right perspective view of a bar hanger assembly.

[0022] FIG. 2B is an exploded top, front, right perspective view of the bar hanger assembly of FIG. 2A.

[0023] FIG. 2C is a front view of a portion of the bar hanger assembly of FIG. 2A.

[0024] FIG. 3A is a right view of the bar hanger holder of FIG. 2A.

[0025] FIG. 3B is a front view of the bar hanger holder of FIG. 3A.

[0026] FIG. 3C is a rear view of the bar hanger holder of FIG. 3A.

[0027] FIG. 3D is a left view of the bar hanger holder of FIG. 3A.

[0028] FIG. 3E is a left, front perspective view of the bar hanger holder of FIG. 3A.

[0029] FIG. 3F is a left, rear perspective view of the bar hanger holder of FIG. 3A.

[0030] FIG. 4A is a right view of the bar hanger of FIG. 2A.

[0031] FIG. 4B is a top, front, right perspective view of the bar hanger of FIG. 4A.

[0032] FIG. 4C is a right view of the pair of bar hangers of FIG. 2A.

[0033] FIG. 4D is a top, front, right perspective view of the pair of bar hangers of FIG. 4C.

[0034] FIG. 5 is a top, front perspective view of the pair of bar hanger heads of FIG. 2A.

[0035] FIG. 6A is a top, front perspective view of another bar hanger assembly with mating telescoping bars.

[0036] FIG. 6B is a front-side view of the bar hanger assembly shown in FIG. 6A.

[0037] FIG. 6C is a rear-side view of the bar hanger assembly shown in FIG. 6A.

[0038] FIG. 6D is a right-side view of the bar hanger assembly shown in FIG. 6A.

[0039] FIG. 6E is a left-side view of the bar hanger assembly shown in FIG. 6A.

[0040] FIG. 6F is a top-side view of the bar hanger assembly shown in FIG. 6A.

[0041] FIG. 6G is a bottom-side view of the bar hanger assembly shown in FIG. 6A.

[0042] FIG. 6H is a left-side view of the bar hanger assembly shown in FIG. 6A without bar hanger heads.

[0043] FIG. 7A is a top, rear perspective view of a bar hanger for the bar hanger assembly with mating telescoping bars shown in FIG. 6A.

[0044] FIG. 7B is a right-side view of the bar hanger shown in FIG. 7A, the left-side view being a mirror image.

[0045] FIG. 7C is a front-side view of the bar hanger shown in FIG. 7A.

[0046] FIG. 7D is a rear-side view of the bar hanger shown in FIG. 7A.

[0047] FIG. 7E is a top-side view of the bar hanger shown in FIG. 7A.

[0048] FIG. 7F is a bottom-side view of the bar hanger shown in FIG. 7A.

[0049] FIG. 8A is a top, front perspective view of a bar hanger holder for the bar hanger assembly with mating telescoping bars shown in FIG. 6A.

[0050] FIG. 8B is a top, rear perspective view of the bar hanger holder shown in FIG. 8A.

[0051] FIG. 8C is a left-side view of the bar hanger holder shown in FIG. 8A, the right-side view being a mirror image.

[0052] FIG. 8D is a front-side view of the bar hanger holder shown in FIG. 8A.

[0053] FIG. 8E is a rear-side view of the bar hanger holder shown in FIG. 8A.

[0054] FIG. 8F is a top-side view of the bar hanger holder shown in FIG. 8A.

[0055] FIG. 8G is a bottom-side view of the bar hanger holder shown in FIG. 8A.

[0056] FIG. 9A is a top, rear perspective view of a first bar hanger head for the bar hanger

assembly with mating telescoping bars shown in FIG. 6A.

[0057] FIG. 9B is a front-side view of the first bar hanger head shown in FIG. 9A.

[0058] FIG. 9C is a rear-side view of the first bar hanger head shown in FIG. 9A.

[0059] FIG. 9D is a left-side view of the first bar hanger head shown in FIG. 9A.

[0060] FIG. 9E is a right-side view of the first bar hanger head shown in FIG. 9A.

[0061] FIG. 9F is a top-side view of the first bar hanger head shown in FIG. 9A.

[0062] FIG. 9G is a bottom-side view of the first bar hanger head shown in FIG. 9A.

[0063] FIG. 10A is a top, rear perspective view of a second bar hanger head for the bar hanger assembly with mating telescoping bars shown in FIG. 6A.

[0064] FIG. 10B is a front-side view of the second bar hanger head shown in FIG. 10A.

[0065] FIG. 10C is a rear-side view of the second bar hanger head shown in FIG. 10A.

[0066] FIG. 10D is a left-side view of the second bar hanger head shown in FIG. 10A.

[0067] FIG. 10E is a right-side view of the second bar hanger head shown in FIG. 10A.

[0068] FIG. 10F is a top-side view of the second bar hanger head shown in FIG. 10A.

[0069] FIG. 10G is a bottom-side view of the second bar hanger head shown in FIG. 10A.

[0070] FIG. 11A is a top, front perspective view of another bar hanger assembly with mating telescoping bars.

[0071] FIG. 11B is a front-side view of the bar hanger assembly shown in FIG. 11A.

[0072] FIG. 11C is a rear-side view of the bar hanger assembly shown in FIG. 11A.

[0073] FIG. 11D is a right-side view of the bar hanger assembly shown in FIG. 11A.

[0074] FIG. 11E is a left-side view of the bar hanger assembly shown in FIG. 11A.

[0075] FIG. 11F is a top-side view of the bar hanger assembly shown in FIG. 11A.

[0076] FIG. 11G is a bottom-side view of the bar hanger assembly shown in FIG. 11A.

[0077] FIG. 11H is a left-side view of the bar hanger assembly shown in FIG. 11A without bar hanger heads.

[0078] FIG. 11I is a top, front perspective view of the bar hanger assembly shown in FIG. 11A with a fastener.

[0079] FIG. 12A is a top, rear perspective view of a bar hanger for the bar hanger assembly with mating telescoping bars shown in FIG. 11A.

[0080] FIG. 12B is a right-side view of the bar hanger shown in FIG. 12A, the left-side view being a mirror image.

[0081] FIG. 12C is a front-side view of the bar hanger shown in FIG. 12A.

[0082] FIG. 12D is a rear-side view of the bar hanger shown in FIG. 12A.

[0083] FIG. 12E is a top-side view of the bar hanger shown in FIG. 12A.

[0084] FIG. 12F is a bottom-side view of the bar hanger shown in FIG. 12A.

[0085] FIG. 13A is a top, front perspective view of a bar hanger holder for the bar hanger assembly with mating telescoping bars shown in FIG. 11A.

[0086] FIG. 13B is a top, rear perspective view of the bar hanger holder shown in FIG. 13A.

[0087] FIG. 13C is a left-side view of the bar hanger holder shown in FIG. 13A, the right-side view being a mirror image.

[0088] FIG. 13D is a front-side view of the bar hanger holder shown in FIG. 13A.

[0089] FIG. 13E is a rear-side view of the bar hanger holder shown in FIG. 13A.

[0090] FIG. 13F is a top-side view of the bar hanger holder shown in FIG. 13A.

[0091] FIG. 13G is a bottom-side view of the bar hanger holder shown in FIG. 13A.

[0092] FIG. 14A is a top, rear perspective view of a first bar hanger head for the bar hanger

assembly with mating telescoping bars shown in FIG. 11A.

[0093] FIG. 14B is a front-side view of the first bar hanger head shown in FIG. 14A.

[0094] FIG. 14C is a rear-side view of the first bar hanger head shown in FIG. 14A.

[0095] FIG. 14D is a left-side view of the first bar hanger head shown in FIG. 14A.

[0096] FIG. 14E is a right-side view of the first bar hanger head shown in FIG. 14A.

[0097] FIG. 14F is a top-side view of the first bar hanger head shown in FIG. 14A.

[0098] FIG. 14G is a bottom-side view of the first bar hanger head shown in FIG. 14A.

[0099] FIG. 15A is a top, rear perspective view of a second bar hanger head for the bar hanger assembly with mating telescoping bars shown in FIG. 11A.

[0100] FIG. 15B is a front-side view of the second bar hanger head shown in FIG. 15A.

[0101] FIG. 15C is a rear-side view of the second bar hanger head shown in FIG. 15A.

[0102] FIG. 15D is a left-side view of the second bar hanger head shown in FIG. 15A.

[0103] FIG. 15E is a right-side view of the second bar hanger head shown in FIG. 15A.

[0104] FIG. 15F is a top-side view of the second bar hanger head shown in FIG. 15A.

[0105] FIG. 15G is a bottom-side view of the second bar hanger head shown in FIG. 15A.

#### DETAILED DESCRIPTION

[0106] Following below are more detailed descriptions of various concepts related to, and implementations of, a bar hanger apparatus, including one or more bar hangers, bar hanger holders, and bar hanger heads, and methods for mechanically coupling a housing (e.g., a can housing for a downlight or a spotlight, a junction box, a frame) to a support structure (e.g., a ceiling, a wall). It should be appreciated that various concepts introduced above and discussed in greater detail below may be implemented in numerous ways. Examples of specific implementations and applications are provided primarily for illustrative purposes so as to enable those skilled in the art to practice the implementations and alternatives apparent to those skilled in the art.

**[0107]** The figures and example implementations described below are not meant to limit the scope of the present implementations to a single embodiment. Other implementations are possible by way of interchange of some or all of the described or illustrated elements. Moreover, where certain elements of the disclosed example implementations may be partially or fully implemented using known components, in some instances only those portions of such known components that are necessary for an understanding of the present implementations are described, and detailed descriptions of other portions of such known components are omitted so as not to obscure the present implementations.

**[0108]** In the discussion below, various examples of a bar hanger assembly are provided, wherein a given example or set of examples showcases one or more particular features of a bar hanger, bar hanger holder, and a bar hanger head. It should be appreciated that one or more features discussed in connection with a given example may be employed in other examples according to the present disclosure, such that the various features disclosed herein may be readily combined in a given system according to the present disclosure (provided that respective features are not mutually inconsistent).

### **[0109] A First Exemplary Bar Hanger Assembly**

**[0110]** FIGS. 2A-2C show an exemplary bar hanger assembly 1000a according to one inventive implementation. The bar hanger assembly 1000a may include a bar hanger holder 1100 to mechanically couple the bar hanger assembly 1000a to a housing (not shown in the figures). Examples of housings with which the bar hanger assembly 1000a may be used include, but are not limited to, a can housing (e.g., for a recessed lighting fixture), a junction box (e.g., to contain one or more electrical connections, and optionally one or more functional elements such as a luminaire), and a frame (e.g., which may have mounted or otherwise mechanically coupled to it one or more can housings or one or more junction boxes).

**[0111]** The bar hanger holder 1100 is used to mechanically guide a pair of bar hangers 1200A and 1200B (collectively referred to herein as the bar hanger 1200), which may be mechanically coupled together in a telescoping manner such that the bar hanger 1200A is slidably adjustable with respect to the bar hanger 1200B. Each bar hanger 1200 may include a bar hanger head 1300A or 1300B (collectively referred to herein as bar hanger head 1300) to couple the bar hanger assembly 1000a



to one or more support structures disposed in the surrounding environment into which the bar hanger assembly is being installed.

**[0112]** The bar hanger holder 1100 is used, in part, to mechanically couple the bar hanger assembly 1000a to a housing (e.g., for a luminaire and/or other functional device). The bar hanger holder 1100 is also employed to guide and/or mechanically constrain the motion of the bar hangers 1200. FIGS. 3A-3F show various views of an exemplary bar hanger holder 1100. It should be appreciated that the top, bottom, front, rear, left, and right views of the bar hanger holder 1100 shown in FIGS. 3A-3F are intended to provide orientation and may not be representative of the actual orientation of the bar hanger holder 1100 when deployed with a housing in a built environment.

**[0113]** The bar hanger holder 1100 may be dimensioned and shaped, based at least in part, on the housing to which the bar hanger assembly 1000a is coupled and the shape and dimensions of the bar hangers 1200 contained, at least in part, therein. For example, the length of the bar hanger holder 1100 (i.e., the length is defined parallel to the direction of slidable adjustment for the bar hangers 1200) may be constrained so as not to exceed the diameter/width of the housing. In another example, the width and height of the bar hanger holder 1100 (i.e., the width and the height are defined orthogonal to the direction for slidable adjustment) may be constrained to be sufficiently large to contain at least two bar hangers 1200 along at least a substantial portion, if not the entirety, of the length of the bar hanger holder 1100.

**[0114]** The bar hanger holder 1100 may include one or more mounting elements 1110 to facilitate mechanical coupling to one or more corresponding receiving elements on a housing. The one or more mounting elements 1110 may be used in conjunction with various coupling mechanisms including, but not limited to, screw fasteners, bolt fasteners, spring clips, friction clips, clamps, resins, adhesives, and any other coupling mechanism known to one of ordinary skill in the art. The bar hanger holder 1100 may also be coupled to various housings including, but not limited to, a can housing of a recessed lighting fixture, a junction box (e.g., to contain one or more electrical connections and/or functional elements, such as a luminaire), or a frame (e.g., which in turn may comprise a can housing and/or a junction box mounted to or otherwise mechanically coupled to the frame).

**[0115]** For example, FIGS. 2B, 3B, and 3C shows the mounting elements 1110 as openings that

allow a bolt fastener or a screw fastener to pass through the mounting elements 1110 and into corresponding opening(s) on the housing. The opening(s) on the housing may be shaped as holes or slots to allow additional adjustment of the housing relative to the bar hanger assembly 1000a (e.g., along an axis orthogonal to the direction for slidable adjustment of the bar hangers 1200). In some implementations, the mounting element 1110 on the bar hanger holder 1100 may be a slot to allow adjustment of the bar hanger assembly 1000a relative to the housing. For example, the mounting elements 1110 may be slots oriented such that the axis aligned to the longer portion of the slot is orthogonal to the direction for slidable adjustment of the bar hangers 1200. If the housing contains a luminaire and is oriented to emit light downwards (e.g., from a ceiling) and the bar hangers are oriented to slidably adjust along a horizontal axis, the mounting elements 1110 may allow the vertical adjustment of the luminaire relative to the bar hanger assembly 1000a. In some implementations, the mounting element 1110 may be a stud integrated into the bar hanger holder 1100 that is inserted through the opening(s) on the housing.

**[0116]** FIG. 3A shows a right view of the bar hanger holder 1100. As shown, the bar hanger holder 1100 may include a top segment 1120, a first segment 1122, and a first middle segment 1124 to contact, at least in part, the bar hanger 1200B. The bar hanger holder 1100 may also include a bottom segment 1126, a second segment 1128, and a second middle segment 1130 to contact, at least in part, the bar hanger 1200A. The various segments of the bar hanger holder 1100 define a channel 1140 to support and guide the bar hangers 1200A and 1200B. In this manner, the respective segments of the bar hanger holder 1100 may physically contact opposing portions of the bar hangers 1200A and 1200B to mechanically constrain the motion of the bar hangers 1200A and 1200B in one or more directions other than the desired direction for slidable adjustment of the bar hangers 1200, thus substantially reducing undesirable play.

**[0117]** For example, the top segment 1120 may contact the top segment 1220 of the bar hanger 1200B and the bottom segment 1126 may contact the bottom segment 1226 of the bar hanger 1200A, thus constraining the motion of the bar hangers 1200A and 1200B along the top-bottom direction. As shown in FIGS. 3B and 3C, the first and second middle segments 1124 and 1130 (not visible in FIGS. 3B and 3C) may extend along only a portion of the length of the bar hanger holder 1100 to provide, in part, sufficient area to contact the bar hangers 1200A and 1200B for mechanical support while the remaining portions of the bar hanger holder 1100 provide sufficient mechanical

rigidity to mechanically support the bar hanger assembly 1000a under normal operating loads.

**[0118]** In some implementations, the bar hanger holder 1100 may impart a compressive force onto the bar hangers 1200A and 1200B. The compressive force may further reduce the presence of gaps and/or spaces between the bar hanger holder 1100 and the bar hangers 1200 (i.e., the main source for unwanted play) to ensure that physical contact between the bar hanger holder 1100 and the bar hangers 1200 is sufficiently maintained as the bar hangers 1200 are slidably adjusted. This may be accomplished, in part, by dimensioning the bar hanger holder 1100 (e.g., changing the offset angle between adjoining segments, reducing the length of a segment) to mechanically interfere with the bar hangers 1200A and 1200B when inserted through the channel 1140 of the bar hanger holder 1100.

**[0119]** For example, the top segment 1120 and the bottom segment 1126 may apply a force onto the top segment 1220 of the bar hanger 1200B and the bottom segment 1226 of the bar hanger 1200A, respectively. The respective forces may be oriented towards each other resulting in the bar hanger holder 1100 pressing the bar hangers 1200A and 1200B from the top and the bottom. Similarly, a compressive force may also be generated by the first and second segments 1122 and 1128 and/or the first and second middle segments 1124 and 1130.

**[0120]** In some implementations, the bar hanger holder 1100 may be shaped such that one segment generates a force that constrains the bar hanger 1200 along one or more axes. For example, if the segments 1120, 1122, 1126, and 1128 were to form a rectangle (differently than shown in FIG. 2A), the force imparted by the top and bottom segments 1120 and 1126 may only constrain the bar hangers 1200 vertically. In other words, the bar hangers 1200 may still move horizontally with respect to the bar hanger holder 1100. On the other hand, if the offset angle between the top and first segments 1120 and 1122 and/or the bottom and second segments 1126 and 1128 is less than 90 degrees (e.g., as shown in FIG. 2A), the resulting forces generated by, for example, the top and bottom segments 1120 and 1126 may constrain the bar hangers 1200 vertically and horizontally.

**[0121]** Additionally, in some implementations, the generation of a compressive force may relax the tolerances used in the manufacture on the bar hanger assembly 1000a. In other words, the tolerances specified for the various dimensions of the bar hanger holder 1100 and the bar hangers 1200 may be larger (corresponding to a greater variance) so long as the respective limits in the

tolerance of each dimension ensure the bar hanger holder 1100 interferes with the bar hangers 1200 along a substantial portion of the length of the respective bar hangers 1200. Interference in this context refers to the bar hanger holder 1100 and the bar hangers 1200 being dimensioned in such a manner that a portion of the bar hanger holder 1100 would nominally intersect the bar hangers 1200 during assembly. However, the bar hanger holder 1100 and the bar hangers 1200 are formed from materials that are deformable; hence, the intersection of the bar hanger holder 1100 with the bar hangers 1200 results in the deformation and corresponding generation of stress resulting in the compressive force between the bar hanger holder 1100 and the bar hangers 1200.

**[0122]** It should be appreciated that the compressive force may generate a corresponding frictional force that to some extent impedes slidable adjustment of the bar hangers 1200 with respect to the bar hanger holder 1100. The magnitude of the compressive force should thus balance between maintaining contact/reducing unwanted movement between the bar hanger holder 1100 and the bar hangers 1200 while enabling a user to slidably adjust the bar hangers 1200 without having to apply excessive force. In some implementations, the frictional force generated between the bar hanger holder 1100 and the bar hangers 1200 may be modified by at least partially coating respective surfaces of the bar hanger holder 1100 and/or the bar hangers 1200 with a lubricant that modifies the coefficient of friction (static and kinetic) as discussed below. A lower coefficient of friction may allow a larger compressive force to be used.

**[0123]** In some implementations, the frictional force may provide the added benefit of preventing unwanted sliding movement between the bar hangers 1200 and the bar hanger holder 1100. For example, when a user is installing a bar hanger assembly coupled to a housing (e.g., which may contain a luminaire), the user may initially position the respective bar hangers 1200A and 1200B and the bar hanger holder 1100 such that the housing is placed at a desired location between support structures. However, as the user begins to mount the bar hanger assembly and housing to the support structure, the weight of the various components in the housing may cause the bar hanger holder 1100 and/or the bar hangers 1200 to slidably move. For example, the user may inadvertently tilt the housing, or the user may be installing the housing such that the bar hangers 1200 are oriented vertically. The user should thus readjust the bar hanger holder 1100 and the bar hangers 1200 in order to continue with the installation, which increases the time and inconvenience for installation.

**[0124]** The magnitude of the frictional force may thus be chosen to reduce or, in some instances, eliminate such unwanted sliding movement by tailoring the coefficient of friction and/or the compressive force between the bar hangers 1200 and the bar hanger holder 1100. In some implementations, the frictional force may be sufficiently large such that the bar hangers 1200 are unable to slidably move with respect to the bar hanger holder 1100 unaided and/or without human intervention.

**[0125]** The angles: (1)  $\theta_1$  defined between the top segment 1120 and the first segment 1122, (2)  $\theta_2$  defined between the first segment 1122 and the first middle segment 1124, (3)  $\theta_3$  defined between the second segment 1128 and the second middle segment 1130, and (4)  $\theta_4$  defined between the bottom segment 1126 and the second segment 1128, may each be about 45 degrees to about 90 degrees. The angles  $\theta_1$ ,  $\theta_2$ ,  $\theta_3$ , and  $\theta_4$  between the various segments may be chosen, in part, based on the shape of the bar hangers 1200 and/or for ease of manufacturability. For example, the exemplary bar hanger holder 1100 in FIG. 3A shows the angles  $\theta_1$ ,  $\theta_2$ ,  $\theta_3$ , and  $\theta_4$  are about 75 degrees, which is chosen, in part, to ensure the bar hanger holder 1100 may be formed from a flat sheet (e.g., from sheet metal) without having to excessively bend said flat sheet by an angle substantially greater than 90 degrees (e.g., greater than or equal to about 135 degrees). In this manner, the bar hanger holder 1100 may be fabricated using fewer manufacturing steps and without having to retool and/or reconfigure various machinery used for manufacturing.

**[0126]** In some implementations, the portions of the bar hanger holder 1100 that contact the bar hangers 1200 may be coated with a lubricant to facilitate slidable adjustment of the bar hangers 1200 by reducing friction. The lubricant may be various types of lubricating materials including, but not limited to, Teflon, graphite, grease, mineral oil, synthetic oil, and any other lubricating materials known to one of ordinary skill in the art. In some implementations, the top segment 1120, the first and second segments 1122 and 1128, the first and second middle segments 1124 and 1130, and the bottom segment 1126 may be shaped such that a relatively small portion of the bar hanger holder 1100 contacts the bar hangers 1200A and 1200B. For example, one or more notches or one or more bumps may be disposed along the length of the bar hanger holder 1100, where the vertex of such features contact the bar hangers 1200A and 1200B. The one or more notches and/or the one or more bumps may be distributed such that multiple points of contact are made along opposing portions of the bar hangers 1200A and 1200B (e.g., top and bottom segments 1120 and

1126, first and second segments 1122 and 1128) for mechanical stability. In this manner, the bar hangers 1200A and 1200B may be mechanically constrained while substantially smaller contact area, thus reducing the friction between the bar hanger holder 1100 and the bar hangers 1200A and 1200B.

**[0127]** In some implementations, the bar hanger holder 1100 may include a locking mechanism (not shown) to constrain the bar hangers 1200 to the bar hanger holder 1100 (e.g., after the housing and the bar hanger assembly 1000a are installed). In some implementations, the locking mechanism may be a bendable tab located along a portion of the bar hanger holder 1100 that, when bent into a locking position, mechanically restricts subsequent motion of the bar hangers 1200A and 1200B. The locking mechanism may also include one or more mechanical stops to limit the extension of the bar hangers 1200A and 1200B. The mechanical stop may be a tab that is bent into, for example, a slotted opening (e.g., opening 1252) along the bar hangers 1200 once the bar hangers 1200 are inserted into the bar hanger holder 1100. In some implementations, the locking mechanism may be an opening on the bar hanger holder 1100 that receives a fastener that applies a sufficiently large compressive force between the bar hanger holder 1100 and the bar hangers 1200 that the bar hangers 1200 are restrained from moving with respect to the bar hanger holder 1100. Exemplary implementations of the locking mechanism are described further below.

**[0128]** The bar hanger holder 1100 may be formed from various metals and polymers including, but not limited to, aluminum, steel, cast iron, tin, brass, polyethylene, and polyvinyl chloride. In some implementations where the bar hanger holder 1100 is formed from metals, the bar hanger holder 1100 may be fabricated from a sheet metal through a series of bending, cutting, and drilling processes to form the desired shape of the bar hanger holder 1100. In some implementations where the bar hanger holder 1100 is formed from plastic, the bar hanger holder 1100 may be fabricated using various processes including, but not limited to, extrusion and injection molding.

**[0129]** The bar hanger 1200 is used to adjust the bar hanger assembly 1000a in order to position the bar hanger heads 1300 to physically contact support structures during installation of a housing. FIGS. 4A-4D show various views of an exemplary bar hanger 1200. It should be appreciated that the top, bottom, front, rear, left, and right views of the bar hanger 1200 shown in FIGS. 4A-4D are intended to provide orientation and may not be representative of the actual orientation of the bar hanger 1200 when deployed with a housing in a built environment.

**[0130]** As shown in FIGS. 4A and 4B, the bar hanger 1200 may be comprised of a top segment 1220, a first segment 1222, a middle segment 1224, a second segment 1226, and a bottom segment 1228 arranged to form a S-shaped cross-section. The bar hanger 1200 may be designed to couple to a substantially identical bar hanger 1200 in a telescoping manner, as shown in FIGS. 4C and 4D. As shown, the bar hanger 1200A is flipped relative to the bar hanger 1200B such that the top segment 1220, the first segment 1222, the second segment 1226, and the bottom segment 1228 of the bar hanger 1200A contacts the bottom segment 1228, the second segment 1226, the first segment 1222, and the top segment 1220 of the bar hanger 1200B, respectively. The angles: (1)  $\alpha_1$  defined between the top segment 1220 and the first segment 1222, (2)  $\alpha_2$  defined between the first segment 1222 and the middle segment 1224, (3)  $\alpha_3$  defined between the second segment 1226 and the middle segment 1224, and (4)  $\alpha_4$  defined between the bottom segment 1228 and the second segment 1226, may each be about 45 degrees to about 90 degrees. The lower bound on the angles  $\alpha_1$ ,  $\alpha_2$ ,  $\alpha_3$ , and  $\alpha_4$  is based, in part, on the ease of manufacturability as smaller angles (corresponding to larger bending angles) may impose additional manufacturing steps and retooling/reconfiguring of various machinery used during manufacture.

**[0131]** In some implementations, the bar hanger 1200 may form recessed/protruding rails. For example, the top segment 1220, the first segment 1222, and the middle segment 1224 may form a first recessed rail on one side (e.g., on the right side in FIG. 4A) and a first protruding rail on the opposite side (e.g., on the left side of FIG. 4A). The middle segment 1224, the second segment 1226, and the bottom segment 1228 may form a second recessed rail on the left side of FIG. 4A and a second protruding rail on the right side of FIG. 4A. The protruding portions of the bar hanger 1200 may be disposed inside the respective recessed portions on another bar hanger 1200. For instance, FIG. 4C shows the first recessed rail of bar hanger 1200A receives the second protruding rail of bar hanger 1200B and second recessed rail of bar hanger 1200B receives the first protruding rail of bar hanger 1200A. As shown, the bar hangers 1200A and 1200B may be substantially nested when engaged with one another, resulting in a smaller overall assembly of bar hangers 1200.

**[0132]** The angles  $\alpha_1$ ,  $\alpha_2$ ,  $\alpha_3$ , and  $\alpha_4$  may be chosen, in part, to reduce the likelihood the bar hangers 1200A and 1200B can separate from one another when a force is applied (e.g., during assembly, regular operating loads) along a direction different from the desired direction for slidable adjustment of the bar hangers 1200A and 1200B (e.g., orthogonal to the desired direction for

slidable adjustment). For instance, the top and bottom segments 1220 and 1228 of the bar hangers 1200A and 1200B may provide sufficient physical contact to mechanically constrain each bar hanger 1200 from moving relative to one another along a top-bottom direction. For a sufficiently small angle  $\alpha_1$  and  $\alpha_4$ , the top and bottom segments 1220 and 1228 of the bar hangers 1200A and 1200B may also mechanically constrain each bar hanger 1200 from moving relative to one another along a front-rear direction as well. The angles  $\alpha_1$ ,  $\alpha_2$ ,  $\alpha_3$ , and  $\alpha_4$  that are sufficient to mechanically constrain the respective bar hangers 1200A and 1200B may also depend on the width of the bar hanger 1200 (the width,  $W$ , being defined along the front-rear direction of the bar hanger 1200 and/or the distance between the segments 1222 and 1226 as shown in FIG. 4A). A wider bar hanger 1200 may allow for larger angles approaching 90 degrees as a wider top segment 1220 may still provide sufficient mechanical constraint, despite the larger angle, to limit unwanted separation of the bar hangers 1200. Furthermore, bar hangers 1200A and 1200B may be substantially identical, thus simplifying manufacture since only one part is fabricated.

**[0133]** By utilizing a design for the bar hanger 1200, as shown in FIGS. 4A-4D, that provides substantial physical contact between two coupled bar hangers 1200 for mechanical constraint, the bar hanger 1200 may also be less sensitive to variabilities caused by manufacturing tolerances. For example, the angle  $\alpha_1$  may be smaller and the angle  $\alpha_4$  may be larger than design specifications, which would generate greater contact between the top and bottom segments 1220 and 1228 of respective bar hangers 1200. If the material used to form the bar hanger 1200 is sufficiently compliant, the bar hanger 1200 may be bent to an appropriate angle by another bar hanger 1200 upon insertion into the other bar hanger 1200.

**[0134]** In some implementations, the bar hangers 1200 may be intentionally designed with a unilateral tolerance to increase the contact between the respective bar hangers 1200, thereby reducing unwanted play. For example, the angle  $\alpha_1$  may be specified as  $75_{-1.0}^{+0.0}$  degrees and the angle  $\alpha_4$  may be specified as  $75_{-0.0}^{+1.0}$  degrees. If the bar hangers 1200A and 1200B are similar, the top segment 1220 of bar hanger 1200A would contact the bottom segment 1228 of the bar hanger 1200B. If the material used to form the bar hanger 1200 is sufficiently stiff, each bar hanger 1200 may apply a compressive force onto the other bar hanger 1200 such that physical contact is maintained as the bar hangers 1200 are slidably adjusted. More generally, the tolerances of the angles  $\alpha_1$ ,  $\alpha_2$ ,  $\alpha_3$ , and  $\alpha_4$  may be tailored according to respective angles of another bar hanger



(substantially similar or different with the bar hanger 1200) that are proximate to  $\alpha_1$ ,  $\alpha_2$ ,  $\alpha_3$ , and  $\alpha_4$  (e.g.,  $\alpha_1$  is proximate to an angle  $\gamma$  of another bar hanger). The tolerances and the resultant compressive force may be adjusted such that frictional forces are not excessive so as to prevent adjustment of the bar hangers 1200 during assembly and under normal operating loads.

**[0135]** Similar to the bar hanger holder 1100, the frictional force between two coupled bar hangers 1200 may be sufficiently large to reduce, or prevent entirely, unwanted sliding motion of each bar hanger 1200 relative to one another. For example, when installing a bar hanger assembly coupled to a housing, each bar hanger 1200 may be slidably adjusted to a desired position. The frictional force between the bar hangers 1200 may be sufficient to maintain the desired position of each bar hanger 1200, particularly as subsequent bar hangers 1200 are then adjusted. In some implementations, the frictional force between two bar hangers 1200 may be adjusted by incorporating a lubricant between the bar hangers 1200. The lubricant may be various types of lubricating materials including, but not limited to, Teflon, graphite, grease, mineral oil, synthetic oil, and any other lubricating materials known to one of ordinary skill in the art.

**[0136]** In some implementations, the top segment 1220, the first and second segments 1222 and 1226, the middle segments 1224, and the bottom segment 1228 of the bar hanger 1200 may also be shaped such that a relatively small portion of the bar hanger 1200 contacts the other bar hanger. For example, one or more notches or one or more bumps may be disposed along the length of the bar hanger 1200, where the vertex of such features contacts a surface on the other bar hanger 1200. The one or more notches and/or the one or more bumps may be distributed such that multiple points of contact are made between the bar hangers 1200A and 1200B (e.g., between the top and bottom segments 1220 and 1228, between the first and second segments 1222 and 1226, between the middle segments 1224) for mechanical stability. In this manner, the physical contact between the bar hangers 1200 may be sufficient to mechanically constrain unwanted relative motion orthogonal to the direction for slidable adjustment of the bar hangers 1200, while the frictional force is reduced when adjusting the bar hangers 1200.

**[0137]** In some implementations, the bar hanger 1200 may include one or more attachment features, disposed at one or both ends of the bar hanger 1200, to couple to the bar hanger head 1300. The attachment features may be used in conjunction with various coupling mechanisms including, but not limited to, screw fasteners, bolt fasteners, spring clips, friction clips, clamps,

resins, adhesives, and any other coupling mechanism known to one of ordinary skill in the art. For example, FIG. 2A-2B shows the exemplary bar hanger 1200 may include one or more holes 1240, disposed along the second segment 1226, which may be aligned to corresponding holes 1322 on the bar hanger head 1300 to be coupled using rivets (not shown). In some implementations, the bar hanger head 1300 may be welded to the bar hanger 1200. In some implementations, the bar hanger head 1300 may be integrally formed with the bar hanger 1200. For example, the bar hanger head 1300 and the bar hanger 1200 may be formed from the same piece of sheet metal during manufacture.

**[0138]** In some implementations, the bar hanger 1200 may also include one or more mechanical stops, disposed at one or both ends of the bar hanger 1200, to mechanically limit the motion of the bar hanger 1200. As shown in FIG. 2A, the mechanical stops may be comprised of a tab 1250, disposed on the second segment 1226, that are bent such that when the bar hanger 1200 is inserted through the bar hanger holder 1100, the end of the tab subsequently contacts a corresponding opening 1252 on the first segment 1222 of another bar hanger 1200, thus preventing the respective bar hangers 1200 from disengaging from one another (see FIG. 2B).

**[0139]** In some implementations, the bar hanger 1200 may also include one or more notches 1260 formed at specified locations along the body of the bar hanger 1200. The notch 1260 may allow a user to break the bar hanger 1200 into smaller sections having a shorter length to facilitate installation of a bar hanger assembly coupled to a housing. For example, the bar hanger assembly coupled to a housing may be installed in an environment where the distance between neighboring support structures is shorter than the length of the bar hanger 1200. For these situations, the bar hanger 1200 may be broken into shorter segments that are then used for installation. In this manner, the bar hanger assembly 1000a may be installed across a larger range of gaps between the support structures. As shown in FIG. 2B, the notch 1260 may be formed by thinning a section of the bar hanger 1200. The thinned section is mechanically weaker, thus when a sufficiently large bending force is applied to the bar hanger 1200, the bar hanger 1200 is more likely to fracture at the notch 1260 (as opposed to another location along the bar hanger 1200).

**[0140]** The bar hanger 1200 may be formed from various materials including, but not limited to, aluminum, steel, cast iron, tin, brass, polyethylene, and polyvinyl chloride. In some implementations where the bar hanger 1200 is formed from metals, the bar hanger 1200 may be

fabricated from a sheet metal through a series of bending, cutting, and drilling processes to form the desired shape of the bar hanger 1200. In some implementations where the bar hanger 1200 is formed from plastic, the bar hanger 1200 may be fabricated using various processes including, but not limited to, extrusion and injection molding.

**[0141]** The bar hanger head 1300 provides the mechanical interface to couple the bar hanger assembly 1000a to various support structures in the built environment. FIG. 5 show exemplary bar hanger heads 1300A and 1300B, which are mirror symmetric variants containing the same features. As shown, the bar hanger head 1300 may include an attachment flange 1320 to couple the bar hanger head 1300 to the bar hanger 1200, a primary mounting flange 1340 to couple the bar hanger head 1300 to a support structure, and a secondary mounting flange 1360 to provide additional mechanical support to the support structure, as shown in FIG. 5. In some implementations, the multiple symmetric variants of the bar hanger head 1300 (e.g., 1300A and 1300B) may be used at respective ends of the bar hanger assembly 1000a shown in FIGS. 2A and 2B.

**[0142]** The attachment flange 1320 may be used to couple the bar hanger head 1300 to the bar hanger 1200 via one or more attachment features disposed on the attachment flange 1320. The attachment features may be used in conjunction with various coupling mechanisms including, but not limited to, screw fasteners, bolt fasteners, spring clips, friction clips, clamps, resins, adhesives, and any other coupling mechanism known to one of ordinary skill in the art. For example, FIG. 5 shows the exemplary bar hanger head 1300 includes the attachment flange 1320 where the plane of the attachment flange 1320 is oriented parallel to the plane defined by the first and second segments 1222 and 1226 of the bar hanger 1200. One or more holes 1322 may be disposed on the attachment flange 1320, aligned to corresponding holes 1322 on the bar hanger head 1300 to be coupled using rivets. However, it should be appreciated other coupling mechanisms may be used to couple the bar hanger head 1300 to the bar hanger 1200 as describe above. A portion of the attachment flange 1320 may be removed to form a gap 1324 that is dimensioned to receive a T-bar support for coupling to the bar hanger head 1300. The attachment flange 1320 may also include a tab A 1326 oriented orthogonally with respect to the attachment flange 1320 and parallel to the primary mounting flange 1340. The tab A 1326 may include a slot to facilitate coupling to a support structure, such as a T-bar support.

**[0143]** The primary mounting flange 1340 may provide several features to allow the bar hanger head 1300 to couple to various types of support structures including, but not limited to, T-bars, joists, and framing structures. In some implementations, the primary mounting flange 1340 may be oriented orthogonally to the attachment flange 1320 such that the plane of the primary mounting flange 1340 is parallel to a plane with a normal vector substantially aligned with the direction for slidable adjustment of the bar hangers 1200. The primary mounting flange 1340 may include various attachment features to accommodate various coupling mechanisms including, but not limited to, screw fasteners, bolt fasteners, spring clips, friction clips, clamps, resins, adhesives, and any other coupling mechanism known to one of ordinary skill in the art. In one example shown in FIG. 5, the primary mounting flange 1340 may include a first wall 1342 and a second wall 1344 protruding from the first wall 1342, as shown in FIG. 5. The second wall 1344 may include a hole 1346 for a screw fastener or a bolt fastener to couple to the support structure. The first wall 1342 may include additional holes 1348 to provide additional reinforcement when attaching the bar hanger head 1300 to the support structure.

**[0144]** As shown in FIG. 5, the primary mounting flange 1340 may also include one or more brace stubs 1350 arranged such that when a T-bar support is inserted through the gap 1324, the brace stubs 1350 may rest (e.g., mounting tab 1356) on at least a portion of the T-bar support. In this manner, the bar hanger head 1300 may be physically placed onto the T-bar support to position the bar hanger head 1300 for subsequent coupling to the T-bar support. The primary mounting flange 1340 may also include a catch 1352, which may be a protruding tab, designed to engage a portion of the T-bar support such that the bar hanger head 1300 may be securely attached to the T-bar support. The primary mounting flange 1340 may also include an additional slot 1354, which may be used to further couple the bar hanger head 1300 to a support structure, such as a T-bar support.

**[0145]** The secondary mounting flange 1360 may be oriented orthogonally with respect to the attachment flange 1320 and the primary mounting flange 1340 and disposed along a bottom edge of the primary mounting flange 1340. In this manner, the secondary mounting flange 1360 may provide additional coupling to the support structure along a direction orthogonal to the primary mounting flange 1340, such as in a wooden or metal joist. Various attachment features may be disposed on the secondary mounting flange 1360 to accommodate various coupling mechanisms including, but not limited to, screw fasteners, bolt fasteners, spring clips, friction clips, clamps,

resins, adhesives, and any other coupling mechanism known to one of ordinary skill in the art. In one example in FIG. 5, the secondary mounting flange 1360 may include a slot 1362 and a hole 1364 to accommodate a screw fastener or a bolt fastener.

**[0146]** In some implementations, the bar hanger assembly 1000a may be coupled to a support structure where the primary mounting flange 1340 is unable to physically contact the desired surface of the support structure due to the presence of the secondary mounting flange 1360. For example, the bar hanger head 1300 may be coupled to a C-shaped or an I-shaped support structure where the primary mounting flange 1340 couples to the web (i.e., the portion of the support structure that supports two opposing flanges). In such cases, the secondary mounting flange 1360 may be designed to be removable to allow the primary mounting flange 1340 to couple to such support structures. As shown in FIG. 5, a portion of the secondary mounting flange 1360 located between where the secondary mounting flange 1360 and the primary mounting flange 1340 join together may be removed. The remaining portions may then be further perforated. In this manner, the secondary mounting flange 1360 may be readily removed by simply bending the secondary mounting flange 1360 relative to the primary mounting flange 1340 until fatigue in the material results in detachment of the secondary mounting flange 1360.

**[0147]** The bar hanger head 1300 may be formed from various materials including, but not limited to, aluminum, steel, cast iron, tin, brass, polyethylene, and polyvinyl chloride. In some implementations where the bar hanger head 1300 is formed from metals, the bar hanger head 1300 may be fabricated from a sheet metal through a series of bending, cutting, and drilling processes to form the desired shape of the bar hanger head 1300. In some implementations where the bar hanger head 1300 is formed from plastic, the bar hanger head 1300 may be fabricated using various processes including, but not limited to, extrusion and injection molding. In some instances, multiple parts formed from sheet metal may be joined together using various attachment methods including, but not limited to, brazing, welding, adhesives, and any other known attachment methods known to one of ordinary skill in the art.

#### **[0148] A Second Exemplary Bar Hanger Assembly**

**[0149]** FIGS. 6A-6H show another exemplary bar hanger assembly 1000b. As shown, the bar hanger assembly 1000b may include similar components as the bar hanger assembly 1000a. For

example, the bar hanger assembly 1000b may include a bar hanger holder 1100 to mechanically couple the bar hanger assembly 1000b to a housing and to mechanically guide the bar hangers 1200A and 1200B. The bar hangers 1200A and 1200B may be telescopically slidable with respect to one another and the bar hanger holder 1100. The bar hangers 1200A and 1200B may each include a bar hanger head 1300A and 1300B, respectively, to couple the bar hanger assembly 1000b to support structures in the environment. It should be appreciated the various features, structures, and materials described with respect to the bar hanger assembly 1000a depicted in FIGS. 2A-2C may also be applied to the bar hanger assembly 1000b shown in FIGS. 6A-6H.

**[0150]** FIGS. 7A-7F show several views of the bar hanger 1200 in the bar hanger assembly 1000b. As shown, the bar hanger 1200 may be substantially similar to the bar hanger 1200 shown in FIGS. 4A-4D. For instance, the bar hanger 1200 may have an S-shaped cross-section comprising a top segment 1220, a first segment 1222, a middle segment, 1224, a second segment 1226, and a bottom segment 1228. As shown, the offset angles  $\alpha_1$ ,  $\alpha_2$ ,  $\alpha_3$ , and  $\alpha_4$  between the segments may be between about 45 degrees and about 90 degrees to provide engagement between the bar hangers 1200A and 1200B and for ease of manufacturability. The bar hanger 1200 may also be configured to impose a compressive force and a frictional force with another bar hanger 1200 to maintain contact and to prevent unwanted sliding motion, respectively. The bar hanger 1200 may also include openings 1240 for coupling to the bar hanger head 1300, a mechanical stop comprising the tab 1250 and opening 1252, and notches 1260.

**[0151]** FIGS. 8A-8G show several views of the bar hanger holder 1100 in the bar hanger assembly 1000b. As shown, the bar hanger holder 1100 shown in FIGS. 8A-8G may include several of the same features as the bar hanger holder 1100 of FIGS. 3A-3F. The bar hanger holder 1100 may have a cross-section defined a top segment 1120, a first segment 1122, and a first middle segment 1124 to contact, at least in part, the bar hanger 1200B. The bar hanger holder 1100 may also include a bottom segment 1126, a second segment 1128, and a second middle segment 1130 to contact, at least in part, the bar hanger 1200A. The respective segments of the bar hanger holder 1100 define a channel 1140 to support and guide the bar hangers 1200A and 1200B.

**[0152]** The bar hanger holder 1100 may include additional features to facilitate manufacture and installation of the housing. For example, the bar hanger holder 1100 may include openings 1150 disposed on the top segments 1120. A flat blade screwdriver may be inserted into the openings

1150 to bend the top segments 1120 downwards in order to lock the position of the bar hangers 1200 and/or to reinforce the coupling between the bar hanger holder 1100 and the bar hangers 1200. Said in another way, the degree of physical contact and the magnitude of the compressive force generated by said contact between the bar hanger holder 1100 and the bar hanger 1200 may be modified by adjusting the position and/or angle  $\alpha_1$  of the top segment 1120 via the openings 1150.

**[0153]** The bar hanger holder 1100 may also include an opening 1170 as the locking mechanism to constrain the bar hangers 1200 to the bar hanger holder 1100 (e.g., after the bar hanger assembly 1000b is installed). The opening 1170 may be disposed on the second segment 1128. The opening 1170 may be used to receive a fastener (not shown) that contacts the bar hanger 1200, thus preventing the bar hangers 1200 from moving with respect to the bar hanger holder 1100.

**[0154]** The bar hanger holder 1100 may also include a stud 1160 as the mounting element 1110 disposed on a flange on the first segment 1122. The stud 1160 may be inserted through an opening on the housing to couple the bar hanger assembly 1000b to said housing. In some implementations, the stud 1160 may be threaded such that a corresponding nut may be used to securely couple the bar hanger holder 1100 to the housing. In some implementations, the opening in the housing may be a slot, thus, the stud 1160 may be used to facilitate adjustment of the bar hanger assembly 1000b along the slot of the housing.

**[0155]** The bar hanger holder 1100 may also include flanges 1180 disposed on the first segment 1122. The flanges 1180 may be used to prevent the bar hanger holder 1100 and, by extension, the bar hanger assembly 1000b from rotating about the stud 1160 during assembly and installation. For example, the two flanges 1180 may be positioned to abut respective sides of the housing. Thus, when securing the bar hanger holder 1100 to the housing, any torque that may be imparted on the bar hanger holder 1100 (e.g., by tightening a nut on the stud 1160), is counteracted by the flanges 1180, which constrain the orientation of the bar hanger holder 1100 with respect to the housing.

**[0156]** FIGS. 9A-9G show several views of the bar hanger head 1300B in the bar hanger assembly 1000b. As shown, the bar hanger head 1300B shown in FIGS. 9A-9G may be substantially similar to the bar hanger head 1300B depicted in FIG. 5. Additionally, the bar hanger head 1300B may include an opening 1370 disposed on the primary mounting flange 1340 for a cable used to secure

the housing (e.g., for a luminaire) to a building structure. The cable may be used to meet appropriate building codes related to buildings located in environments subject to earthquake/seismic activity. The bar hanger head 1300B may also include additional openings 1372 on the primary mounting flange 1340 for various types of fasteners to couple the bar hanger head 1300B to a wood or metal stud. FIGS. 10A-10G show several views of the bar hanger head 1300A in the bar hanger assembly 1000b. As shown, the bar hanger head 1300A may be mirror symmetric with the bar hanger head 1300B. Thus, the bar hanger head 1300A may include the same features used to couple the bar hanger assembly 1000b to the various support structures described above.

### **[0157] A Third Exemplary Bar Hanger Assembly**

**[0158]** FIGS. 11A-11I show another exemplary bar hanger assembly 1000c. As shown, the bar hanger assembly 1000c may include similar components as the bar hanger assemblies 1000a and 1000b. For example, the bar hanger assembly 1000b may include a bar hanger holder 1100 to mechanically couple the bar hanger assembly 1000b to a housing and to mechanically guide the bar hangers 1200A and 1200B. The bar hangers 1200A and 1200B may be telescopically slidable with respect to one another and the bar hanger holder 1100. The bar hangers 1200A and 1200B may each include a bar hanger head 1300A and 1300B, respectively, to couple the bar hanger assembly 1000b to support structures in the environment. FIG. 11I shows a fastener 1400 may be used to lock the positions of the bar hanger holder 1100 and the bar hangers 1200A and 1200B. It should be appreciated the various features, structures, and materials described with respect to the bar hanger assembly 1000a depicted in FIGS. 2A-2C and/or bar hanger assembly 1000b depicted in FIGS. 6A-6H may also be applied to the bar hanger assembly 1000c shown in FIGS. 11A-11I.

**[0159]** FIGS. 12A-12F show several views of the bar hanger 1200 in the bar hanger assembly 1000c. As shown, the bar hanger 1200 may be substantially similar to the bar hanger 1200 shown in FIGS. 4A-4D and 7A-7F.

**[0160]** FIGS. 13A-13G show several views of the bar hanger holder 1100 in the bar hanger assembly 1000c. As shown, the bar hanger holder 1100 may be substantially similar to the bar hanger holder 1100 shown in 7A-7G. For instance, the bar hanger holder 1100 includes openings 1150 on the top segment 1120, an opening 1170 as the locking mechanism for the fastener 1400, a stud



1160 for coupling to a housing, and flanges 1180 to prevent rotation of the bar hanger assembly 1000c when coupling the bar hanger holder 1100 to the housing.

**[0161]** FIGS. 14A-14G show several views of the bar hanger head 1300B in the bar hanger assembly 1000c. As shown, the bar hanger head 1300B may be similar to the bar hanger heads 1300B shown in FIG. 5 and 9A-10G. The bar hanger head 1300B may further include an opening 1374 that intersects the tab 1356 on the primary mounting flange 1340. The opening 1374 may be used for a self-drilling fastener to couple the bar hanger head 1300B to a T-bar. FIGS. 15A-15G show several views of the bar hanger head 1300A in the bar hanger assembly 1000c. Similar to the bar hanger heads previous shown, the bar hanger head 1300A may also be mirror symmetric with the bar hanger head 1300B. The bar hanger head 1300A may thus include the same features to couple the bar hanger assembly 1000c to the various support structures described above.

#### **[0162] Conclusion**

**[0163]** All parameters, dimensions, materials, and configurations described herein are meant to be exemplary and the actual parameters, dimensions, materials, and/or configurations will depend upon the specific application or applications for which the inventive teachings is/are used. It is to be understood that the foregoing embodiments are presented primarily by way of example and that, within the scope of the appended claims and equivalents thereto, inventive embodiments may be practiced otherwise than as specifically described and claimed. Inventive embodiments of the present disclosure are directed to each individual feature, system, article, material, kit, and/or method described herein.

**[0164]** In addition, any combination of two or more such features, systems, articles, materials, kits, and/or methods, if such features, systems, articles, materials, kits, and/or methods are not mutually inconsistent, is included within the inventive scope of the present disclosure. Other substitutions, modifications, changes, and omissions may be made in the design, operating conditions and arrangement of respective elements of the exemplary implementations without departing from the scope of the present disclosure. The use of a numerical range does not preclude equivalents that fall outside the range that fulfill the same function, in the same way, to produce the same result.

**[0165]** Also, various inventive concepts may be embodied as one or more methods, of which at

least one example has been provided. The acts performed as part of the method may in some instances be ordered in different ways. Accordingly, in some inventive implementations, respective acts of a given method may be performed in an order different than specifically illustrated, which may include performing some acts simultaneously (even if such acts are shown as sequential acts in illustrative embodiments).

**[0166]** All publications, patent applications, patents, and other references mentioned herein are incorporated by reference in their entirety.

**[0167]** All definitions, as defined and used herein, should be understood to control over dictionary definitions, definitions in documents incorporated by reference, and/or ordinary meanings of the defined terms.

**[0168]** The indefinite articles “a” and “an,” as used herein in the specification and in the claims, unless clearly indicated to the contrary, should be understood to mean “at least one.”

**[0169]** The phrase “and/or,” as used herein in the specification and in the claims, should be understood to mean “either or both” of the elements so conjoined, *i.e.*, elements that are conjunctively present in some cases and disjunctively present in other cases. Multiple elements listed with “and/or” should be construed in the same fashion, *i.e.*, “one or more” of the elements so conjoined. Other elements may optionally be present other than the elements specifically identified by the “and/or” clause, whether related or unrelated to those elements specifically identified. Thus, as a non-limiting example, a reference to “A and/or B”, when used in conjunction with open-ended language such as “comprising” can refer, in one embodiment, to A only (optionally including elements other than B); in another embodiment, to B only (optionally including elements other than A); in yet another embodiment, to both A and B (optionally including other elements); etc.

**[0170]** As used herein in the specification and in the claims, “or” should be understood to have the same meaning as “and/or” as defined above. For example, when separating items in a list, “or” or “and/or” shall be interpreted as being inclusive, *i.e.*, the inclusion of at least one, but also including more than one, of a number or list of elements, and, optionally, additional unlisted items. Only terms clearly indicated to the contrary, such as “only one of” or “exactly one of,” or, when used in the claims, “consisting of,” will refer to the inclusion of exactly one element of a number

or list of elements. In general, the term “or” as used herein shall only be interpreted as indicating exclusive alternatives (*i.e.* “one or the other but not both”) when preceded by terms of exclusivity, such as “either,” “one of,” “only one of,” or “exactly one of.” “Consisting essentially of,” when used in the claims, shall have its ordinary meaning as used in the field of patent law.

**[0171]** As used herein in the specification and in the claims, the phrase “at least one,” in reference to a list of one or more elements, should be understood to mean at least one element selected from any one or more of the elements in the list of elements, but not necessarily including at least one of each and every element specifically listed within the list of elements and not excluding any combinations of elements in the list of elements. This definition also allows that elements may optionally be present other than the elements specifically identified within the list of elements to which the phrase “at least one” refers, whether related or unrelated to those elements specifically identified. Thus, as a non-limiting example, “at least one of A and B” (or, equivalently, “at least one of A or B,” or, equivalently “at least one of A and/or B”) can refer, in one embodiment, to at least one, optionally including more than one, A, with no B present (and optionally including elements other than B); in another embodiment, to at least one, optionally including more than one, B, with no A present (and optionally including elements other than A); in yet another embodiment, to at least one, optionally including more than one, A, and at least one, optionally including more than one, B (and optionally including other elements); etc.

**[0172]** In the claims, as well as in the specification above, all transitional phrases such as “comprising,” “including,” “carrying,” “having,” “containing,” “involving,” “holding,” “composed of,” and the like are to be understood to be open-ended, *i.e.*, to mean including but not limited to. Only the transitional phrases “consisting of” and “consisting essentially of” shall be closed or semi-closed transitional phrases, respectively, as set forth in the United States Patent Office Manual of Patent Examining Procedures, Section 2111.03.

## CLAIMS

1. A bar hanger, comprising:  
a rod having a S-shaped cross-section comprising:  
a bottom segment;  
a first segment, coupled to a first end of the bottom segment, that is parallel to a first axis, the first and bottom segments defining a first offset angle;  
a middle segment coupled to a first end of the first segment, the middle and first segments defining a second offset angle;  
a second segment, coupled to a first end of the middle segment, that is parallel to the first axis, the second and middle segments defining a third offset angle; and  
a top segment coupled to a first end of the second segment, the top and second segments defining a fourth offset angle,  
the first, second, third, and fourth offset angles are between about 45 degrees and about 90 degrees.
2. The bar hanger of claim 1, wherein the first segment forms a rounded corner with at least one of the bottom or middle segments.
3. The bar hanger of claim 1, wherein:  
the bottom, first, and middle segments define a first section and the middle, second, and top segments define a second section,  
the first section being able to fit within a recess formed by the second section of another bar hanger.
4. The bar hanger of claim 1, wherein the rod is covered with a lubricant.
5. The bar hanger of claim 1, further comprising:  
an opening, disposed at an end of the rod on at least one of the first or second segments, to receive a connector that couples the rod to a bar hanger head.
6. The bar hanger of claim 5, further comprising:

the connector to couple the rod to the bar hanger head, the connector being at least one of a rivet, a bolt, a screw fastener, or a snap-fit connector.

7. The bar hanger of claim 1, further comprising:

a tab, disposed at an end of the rod on at least one of the first or second segments, to prevent the bar hanger from mechanically disengaging another bar hanger when bent.

8. The bar hanger of claim 1, further comprising:

a notch, disposed on the rod, to facilitate the fracture of the rod into a first portion and a second portion when a sufficiently large bending force is applied to the rod, the first and second portions having a length shorter than a length of the rod.

9. A bar hanger assembly comprising:

a first bar hanger that is a bar hanger of any of claims 1 through 8; and

a second bar hanger that is a bar hanger of any of claims 1 through 8,

the second bar hanger being coupled to the first hanger such that (1) the top segment of the first bar hanger at least partially contacts the bottom segment of the second bar hanger, (2) the bottom segment of the first hanger at least partially contacts the top segment of the second bar hanger, and (3) the second bar hanger is telescopically movable with respect to the first bar hanger.

10. The bar hanger assembly of claim 9, wherein the first and second bar hangers are dimensioned such that the top segment of the first bar hanger mechanically interferes with the bottom segment of the second bar hanger and the bottom segment of the first bar hanger mechanically interferes with the top segment of the second bar hanger.

11. The bar hanger assembly of claim 9, wherein the contact between the top and bottom segments of the first bar hanger and the bottom and top segments of the second bar hanger, respectively, generates a sufficiently large frictional force to prevent the first bar hanger from moving relative to the second hanger without human intervention.

12. The bar hanger assembly of claim 9, wherein:

the top segment of the first bar hanger imparts a first force against the bottom segment of the second bar hanger and the top segment of the second bar hanger imparts a second force against the bottom segment of the first bar hanger,

the first and second forces being oriented such that a compressive force is generated between the first and second bar hangers.

13. The bar hanger assembly of claim 12, wherein the compressive force prevents the first bar hanger from moving with respect to the second bar hanger along the first axis of the first bar hanger without human intervention and a second axis of the first bar hanger that is not parallel to the first axis.

14. The bar hanger assembly of claim 9, further comprising:

a first bar hanger head coupled to an end of the first bar hanger, the first bar hanger head being used to couple the bar hanger assembly to at least one of a T-bar, a joist, or a stud.

15. The bar hanger assembly of claim 14, wherein the first bar hanger head is welded to the first bar hanger.

16. The bar hanger assembly of claim 14, wherein the first bar hanger head is integrally formed with the first bar hanger.

17. The bar hanger assembly of claim 9, further comprising:

a bar hanger holder defining a channel through which the first and second bar hangers are slidably movable with respect to the bar hanger holder.

18. The bar hanger assembly of claim 17, wherein respective portions of the first and second bar hangers contact the bar hanger holder so as to reduce lateral movement of the first and second bar hangers with respect to the bar hanger holder along an axis that is not parallel to the first axis of at least one of the first or second bar hangers.

19. The bar hanger assembly of claim 17, wherein the bar hanger holder includes an opening to receive a fastener that couples the bar hanger holder to a housing.
20. The bar hanger assembly of claim 19, further comprising:  
the fastener to couple the bar hanger holder to the housing, the housing being at least one of a can housing or a junction box.
21. The bar hanger assembly of claim 19, wherein the opening of the bar hanger holder is a slot that allows the bar hanger holder and the first and second bar hangers to be movable with respect to the housing along an axis defined by the slot.
22. A bar hanger assembly, comprising:  
a first bar hanger; and  
a second bar hanger coupled to the first bar hanger,  
the second bar hanger being telescopically slidable with respect to the first bar hanger along an axis,  
a portion of the second bar hanger contacting a portion of the first bar hanger such that a compressive force is generated between the first and second bar hangers, the compressive force substantially reducing movement of the second bar hanger with respect to the first bar hanger along a direction that is not parallel to the axis.
23. The bar hanger assembly of claim 22, wherein the first bar hanger is substantially identical to the second bar hanger.
24. The bar hanger assembly of claim 22, wherein the first and second bar hangers each have a S-shaped cross-section.
25. The bar hanger assembly of claim 22, wherein:  
the portion of the first bar hanger forms a recessed rail structure,  
the portion of the second hanger forms a protruding rail structure,  
the protruding rail being able to fit substantially in the recessed rail section.

26. The bar hanger assembly of claim 22, wherein at least one of the first or second bar hangers is coated with a lubricant.
27. The bar hanger assembly of claim 22, wherein the compressive force prevents the first bar hanger from moving unaided with respect to the second bar hanger along the axis.
28. The bar hanger assembly of claim 22, further comprising:  
a first bar hanger head coupled to an end of the first bar hanger, the first bar hanger head being used to couple the bar hanger assembly to at least one of a T-bar, a joist, or a stud.
29. The bar hanger assembly of claim 28, wherein the first bar hanger head is welded to the first bar hanger.
30. The bar hanger assembly of claim 28, wherein the first bar hanger head is integrally formed with the first bar hanger.
31. The bar hanger assembly of claim 22, further comprising:  
a bar hanger holder defining a channel through which the first and second bar hangers are slidably movable with respect to the bar hanger holder.
32. The bar hanger assembly of claim 31, wherein respective portions of the first and second bar hangers contact the bar hanger holder so as to reduce lateral movement of the first and second bar hangers with respect to the bar hanger holder along an axis that is not parallel to the first axis of at least one of the first or second bar hangers.
33. The bar hanger assembly of claim 31, wherein the bar hanger holder includes an opening to receive a fastener that couples the bar hanger holder to a housing.
34. The bar hanger assembly of claim 33, further comprising:



the fastener to couple the bar hanger holder to the housing, the housing being at least one of a can housing or a junction box.

35. The bar hanger assembly of claim 33, wherein the opening of the bar hanger holder is a slot that allows the bar hanger holder and the first and second bar hangers to be movable with respect to the housing along an axis defined by the slot.

36. A bar hanger assembly, comprising:

a first bar hanger having a first cross-section comprising a first series of connected segments; and

a second bar hanger, coupled to the first bar hanger, having a second cross-section comprising a second series of connected segments,

the second bar hanger being telescopically slidable with respect to the first bar hanger along an axis,

each pair of adjoining segments in the first and second series of connected segments defining an offset angle between about 45 degrees and about 90 degrees,

a subset of the first series of connected segments contacting a subset of the second series of connected segments such that movement of the second bar hanger with respect to the first bar hanger along a direction not parallel to the axis is substantially constrained.

37. The bar hanger assembly of claim 36, wherein the first bar hanger is substantially identical to the second bar hanger.

38. The bar hanger assembly of claim 36, wherein the first and second series of segments forms a S-shape.

39. The bar hanger assembly of claim 36, wherein at least one pair of connected segments in the first series of connected segments forms a rounded corner.

40. The bar hanger assembly of claim 36, wherein:

a first subset of the first series of connected segments forms a recessed rail section,

a second subset of the second series of connected segments forms a protruding rail section, the protruding rail being able to fit substantially in the recessed rail section.

41. The bar hanger assembly of claim 36, wherein at least one of the first or second bar hangers is coated with a lubricant.

42. The bar hanger assembly of claim 36, wherein the subset of the first series of connected segments contacting the subset of the second series of connected segments generates a compressive force between the first and second bar hangers.

43. The bar hanger assembly of claim 42, wherein the compressive force prevents the first bar hanger from moving unaided with respect to the second bar hanger along the axis.

44. The bar hanger assembly of claim 36, further comprising:  
a first bar hanger head coupled to an end of the first bar hanger, the first bar hanger head being used to couple the bar hanger assembly to at least one of a T-bar, a joist, or a stud.

45. The bar hanger assembly of claim 44, wherein the first bar hanger head is welded to the first bar hanger.

46. The bar hanger assembly of claim 44, wherein the first bar hanger head is integrally formed with the first bar hanger.

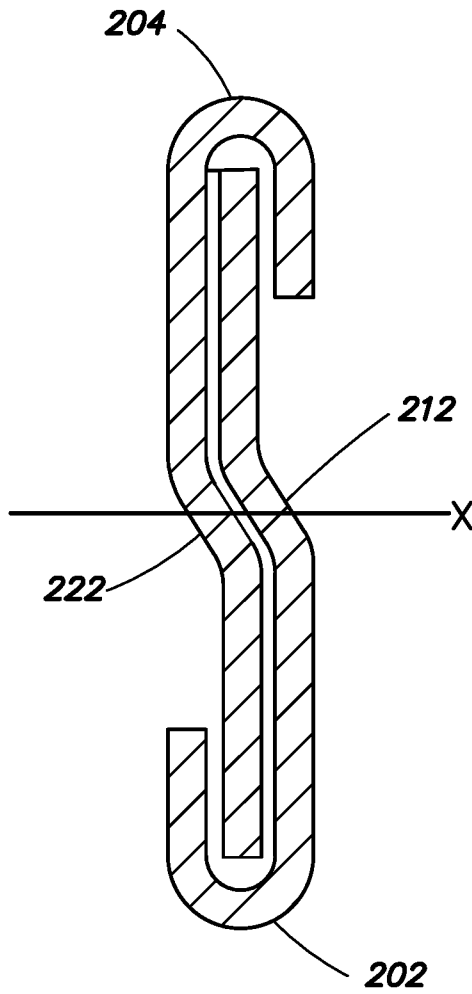
47. The bar hanger assembly of claim 36, further comprising:  
a bar hanger holder defining a channel through which the first and second bar hangers are slidably movable with respect to the bar hanger holder.

48. The bar hanger assembly of claim 47, wherein respective portions of the first and second bar hangers contact the bar hanger holder so as to reduce lateral movement of the first and second bar hangers with respect to the bar hanger holder along an axis that is not parallel to the first axis of at least one of the first or second bar hangers.

49. The bar hanger assembly of claim 47, wherein the bar hanger holder includes an opening to receive a fastener that couples the bar hanger holder to a housing.

50. The bar hanger assembly of claim 49, further comprising:  
the fastener to couple the bar hanger holder to the housing, the housing being at least one of a can housing or a junction box.

51. The bar hanger assembly of claim 49, wherein the opening of the bar hanger holder is a slot that allows the bar hanger holder and the first and second bar hangers to be movable with respect to the housing along an axis defined by the slot.



**FIG. 1**  
(Prior Art)

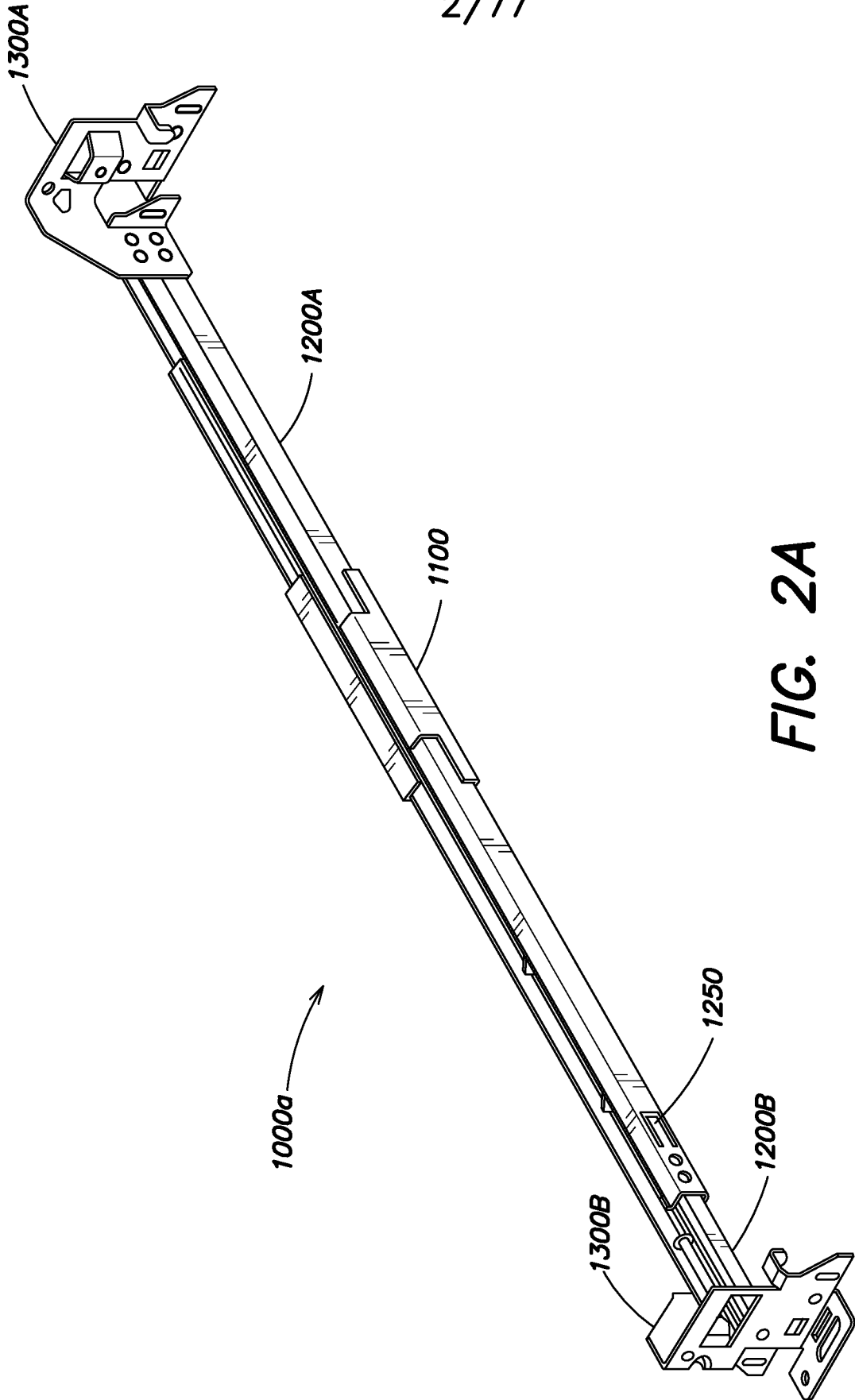


FIG. 2A

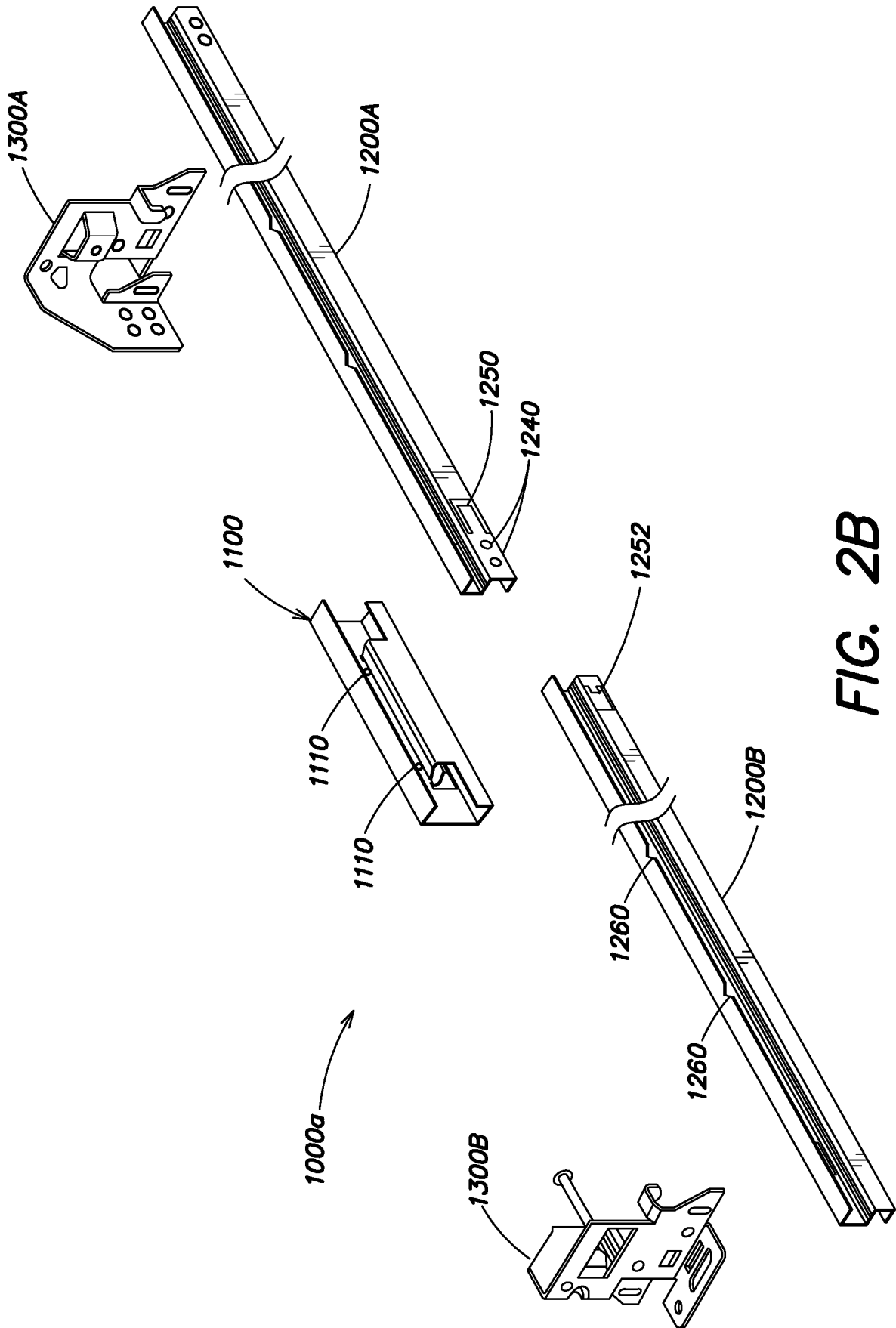
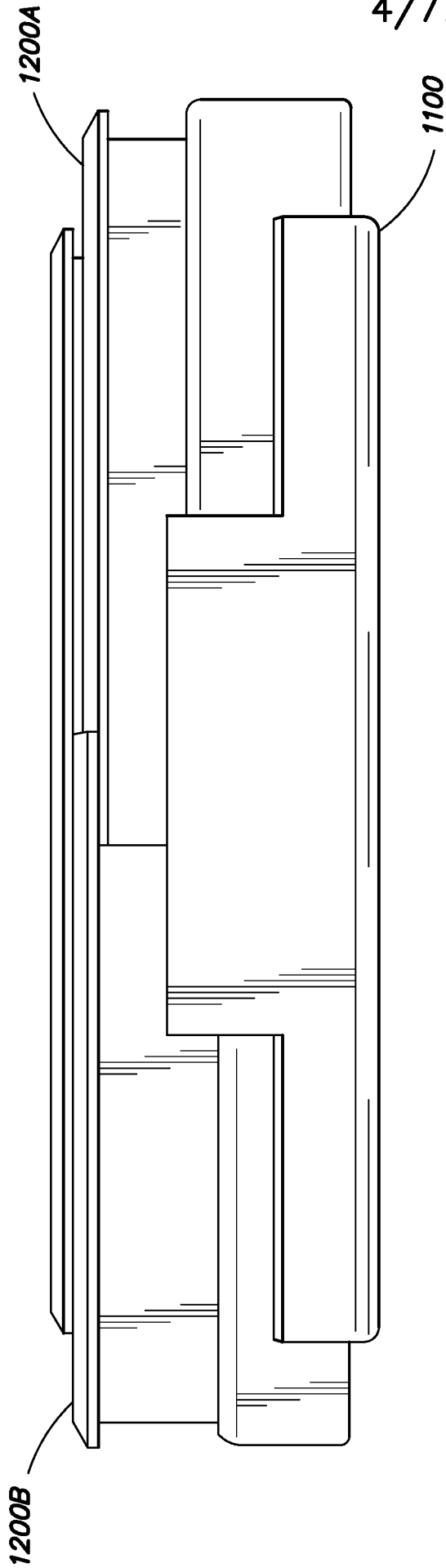


FIG. 2B



**FIG. 2C**

5/77

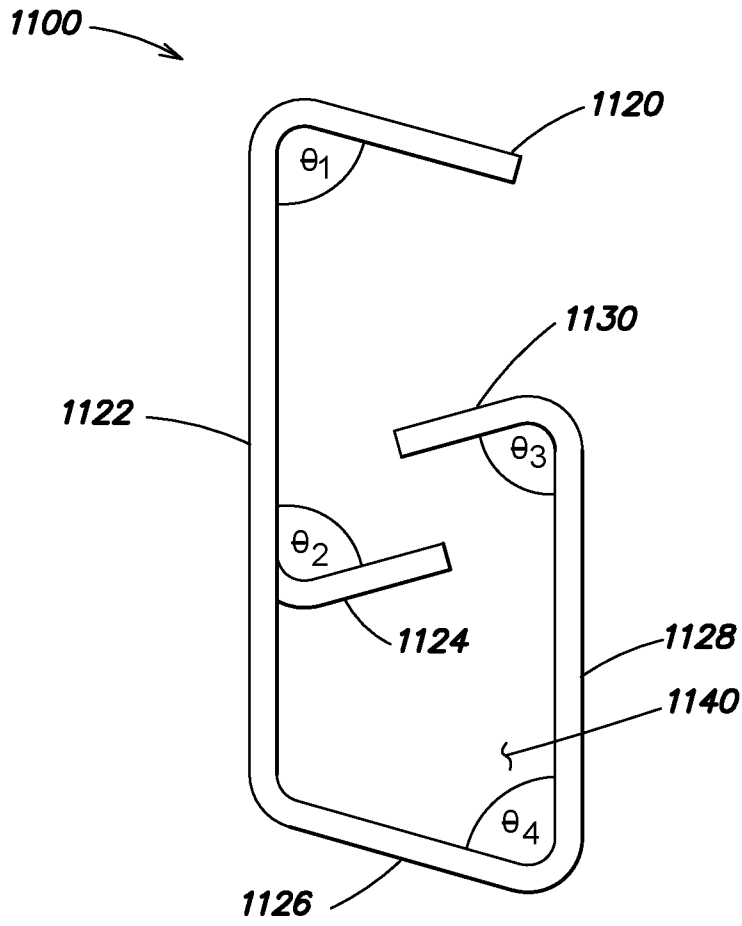
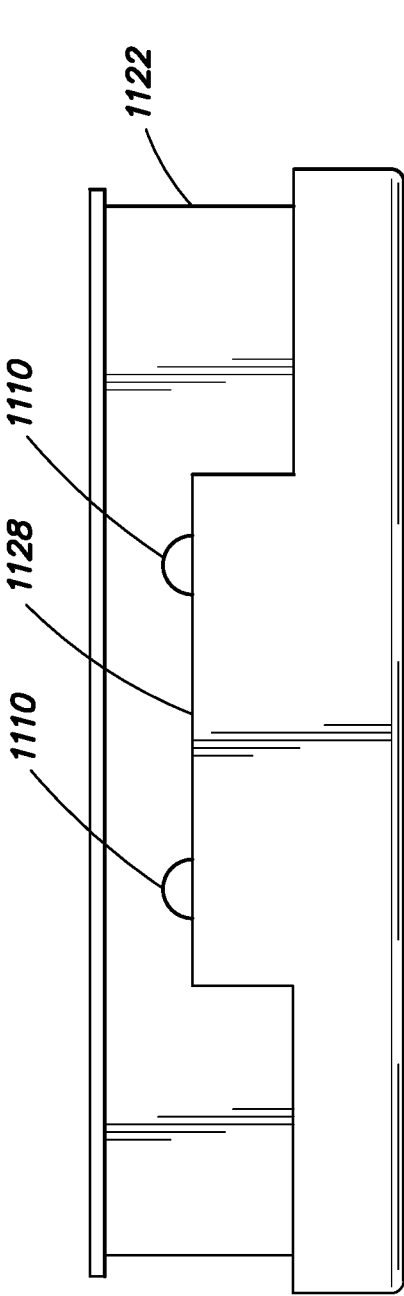
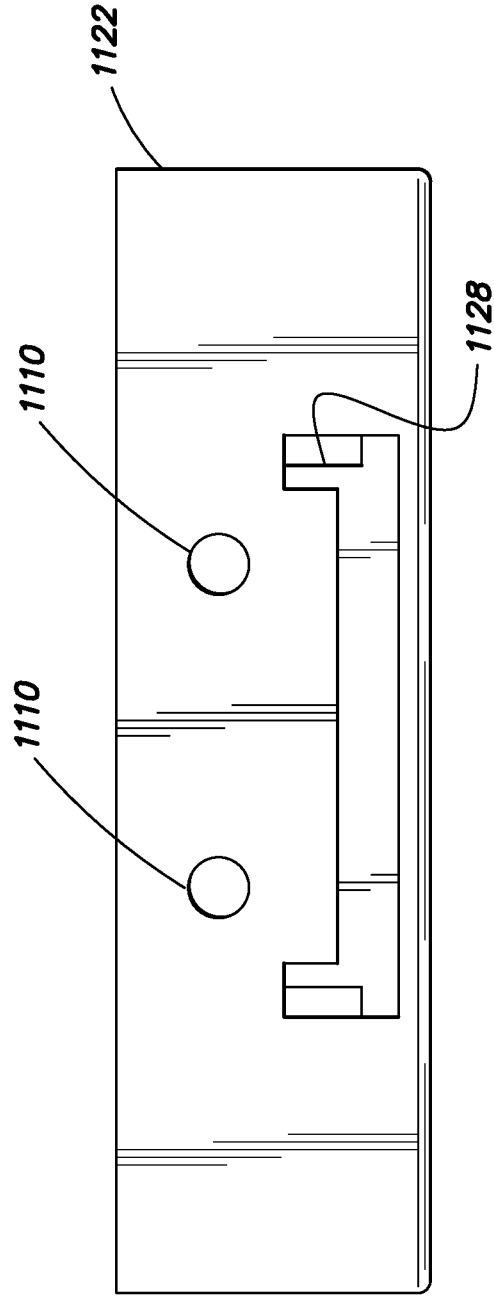


FIG. 3A

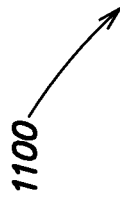
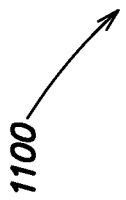


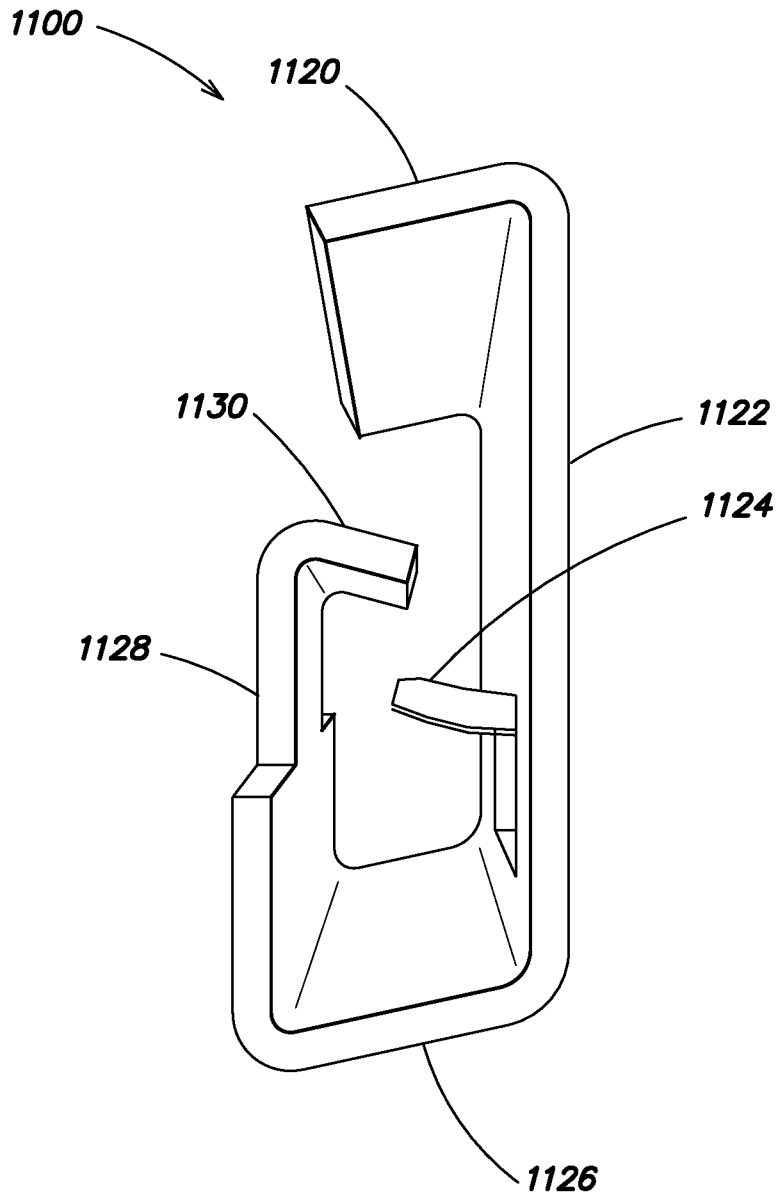


**FIG. 3B**

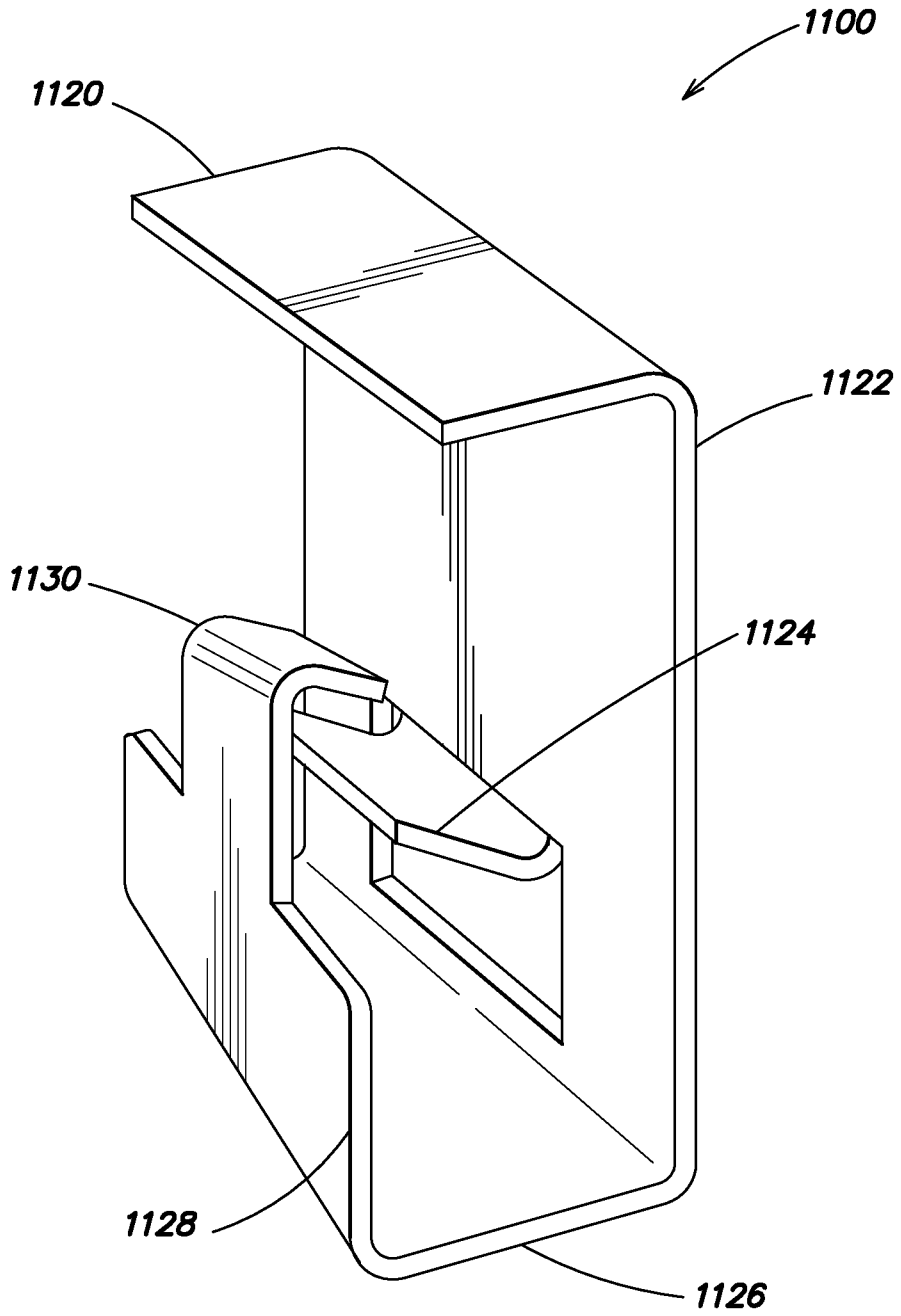


**FIG. 3C**





**FIG. 3D**



**FIG. 3E**

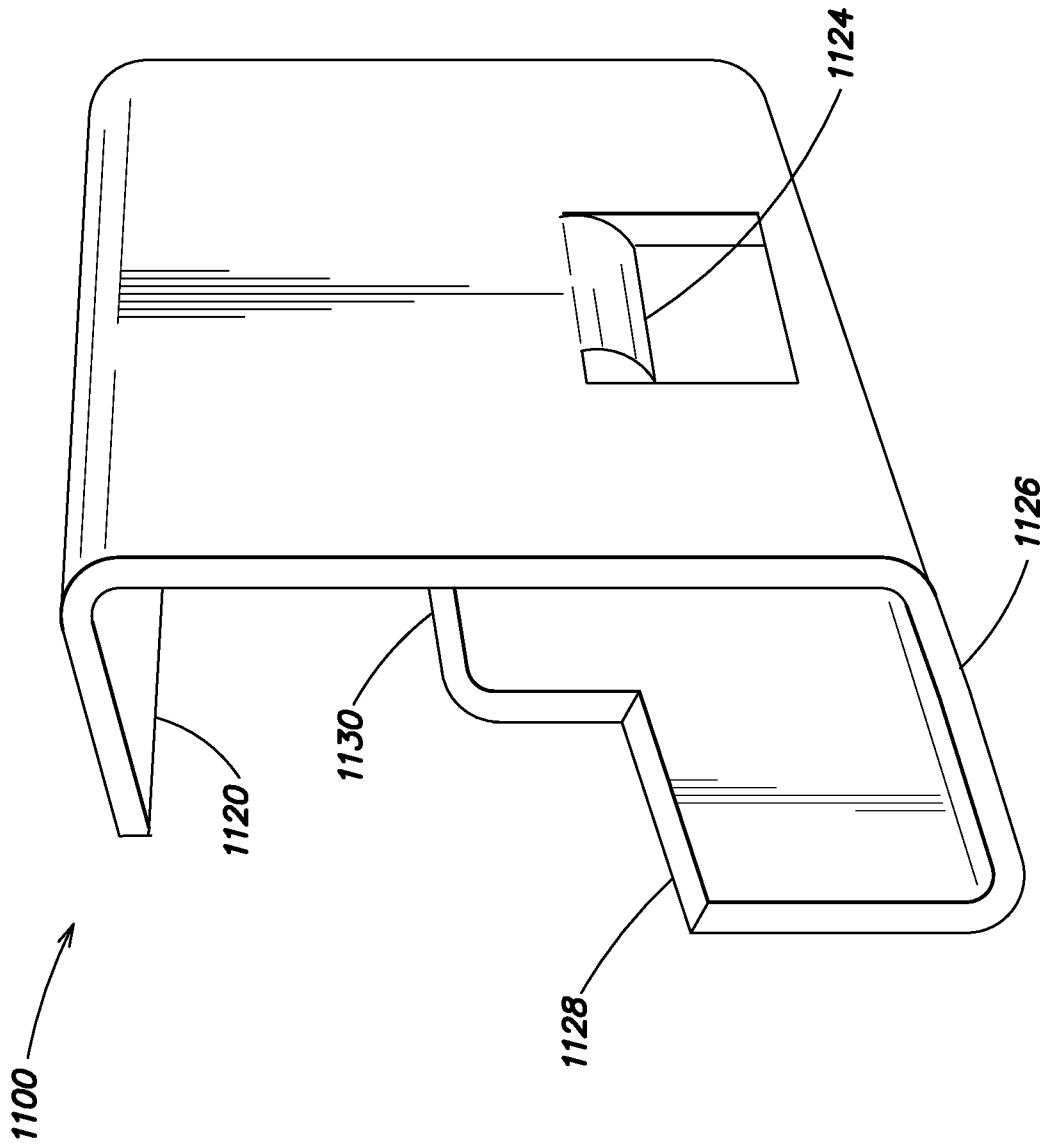


FIG. 3F

10/77

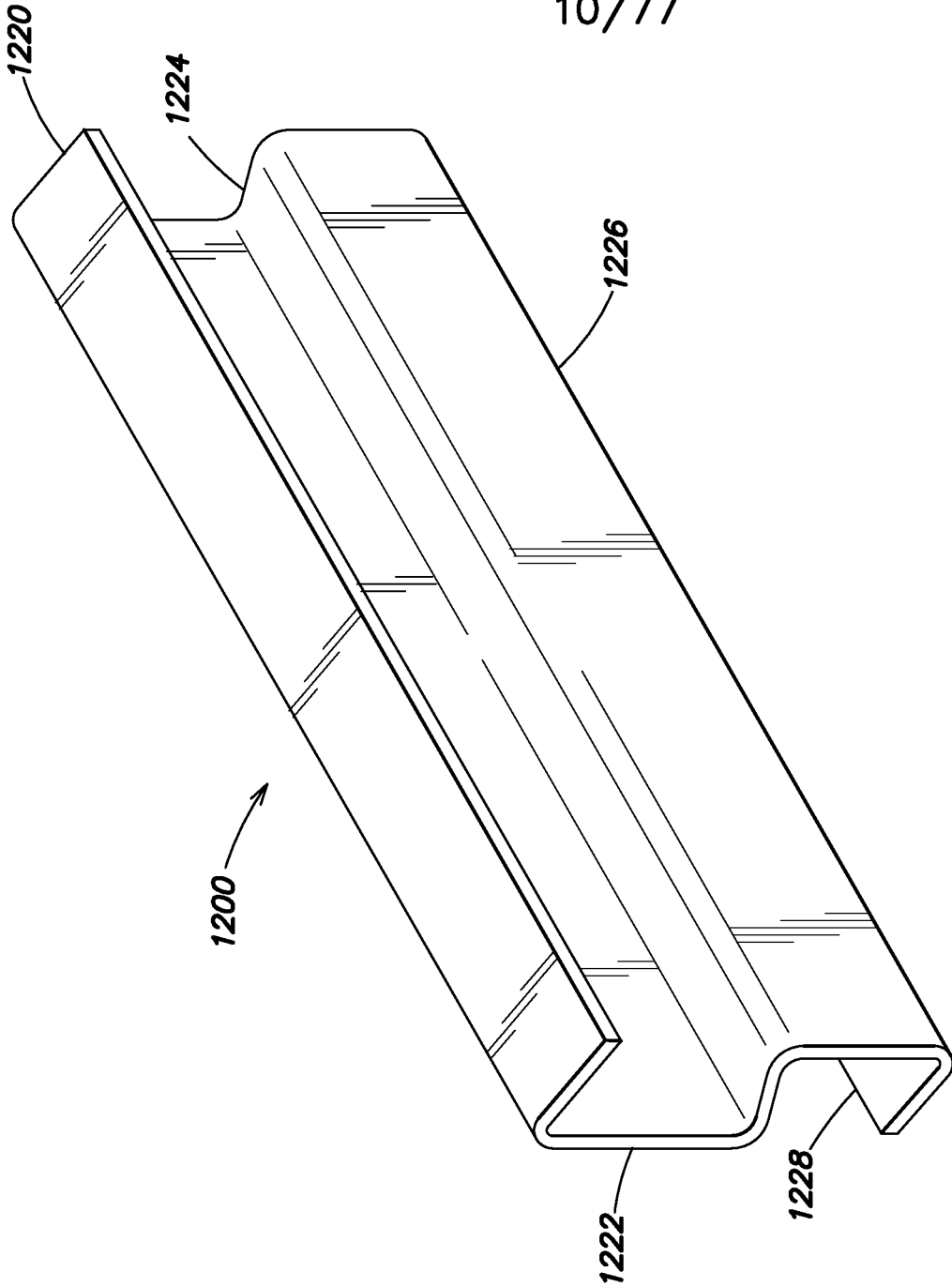


FIG. 4B

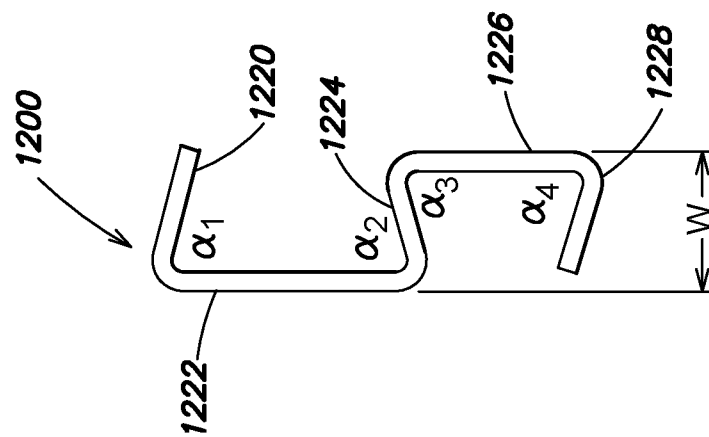
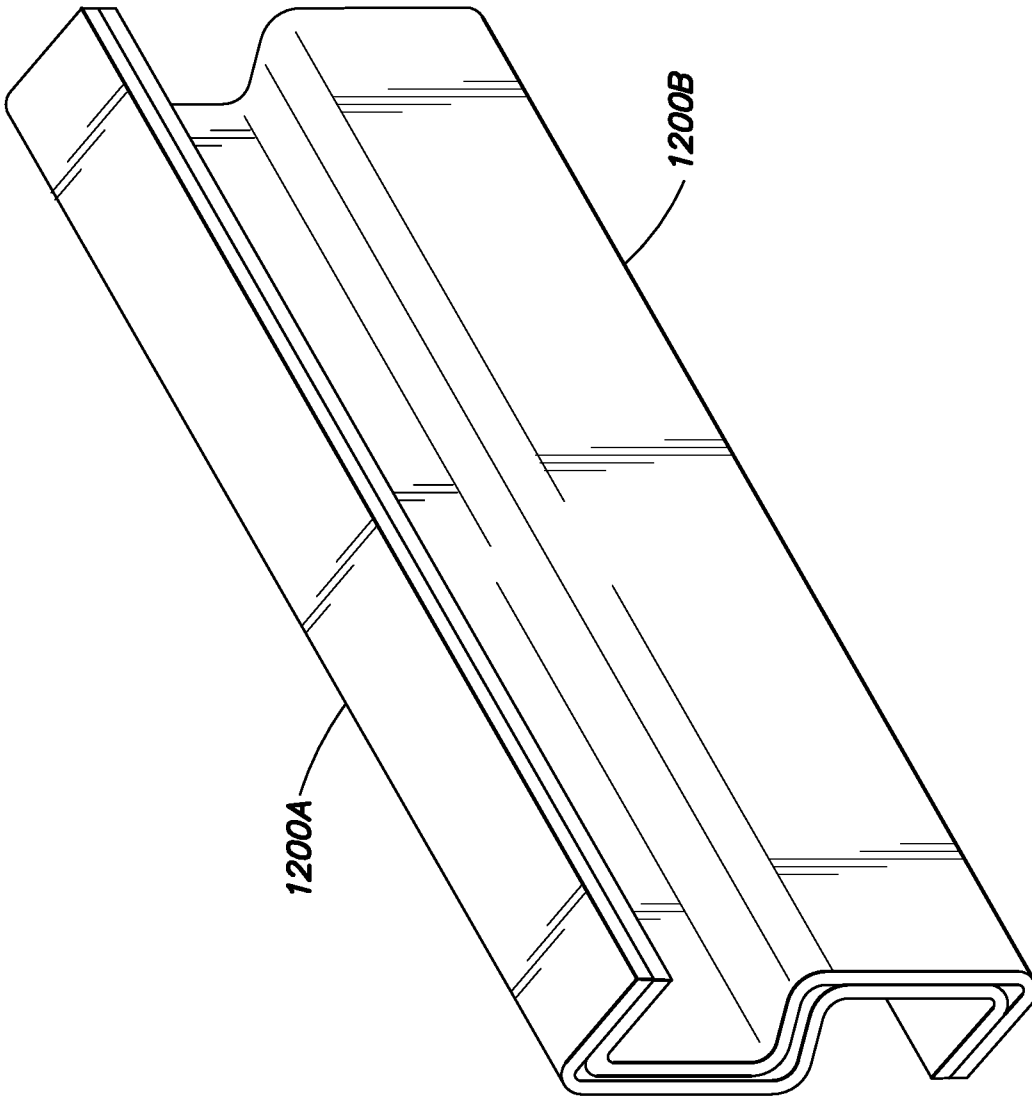
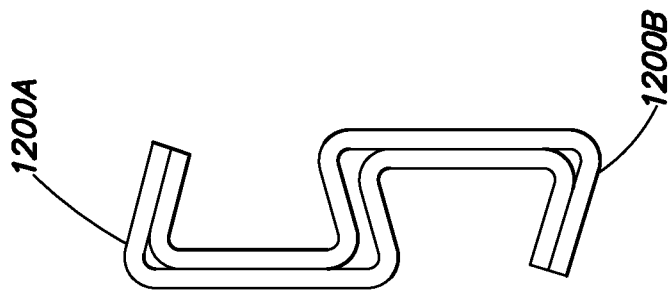


FIG. 4A



**FIG. 4D**



**FIG. 4C**

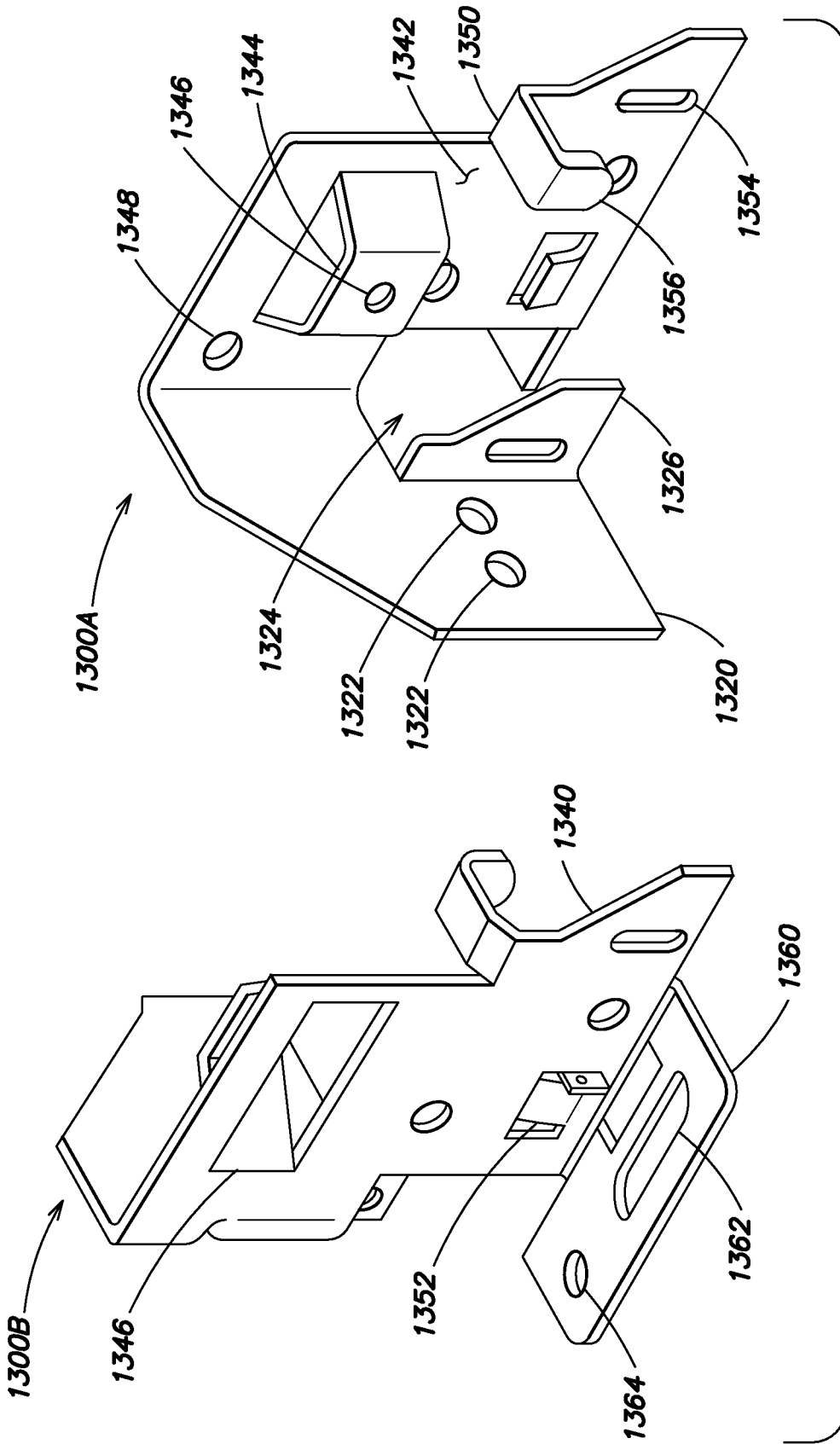


FIG. 5

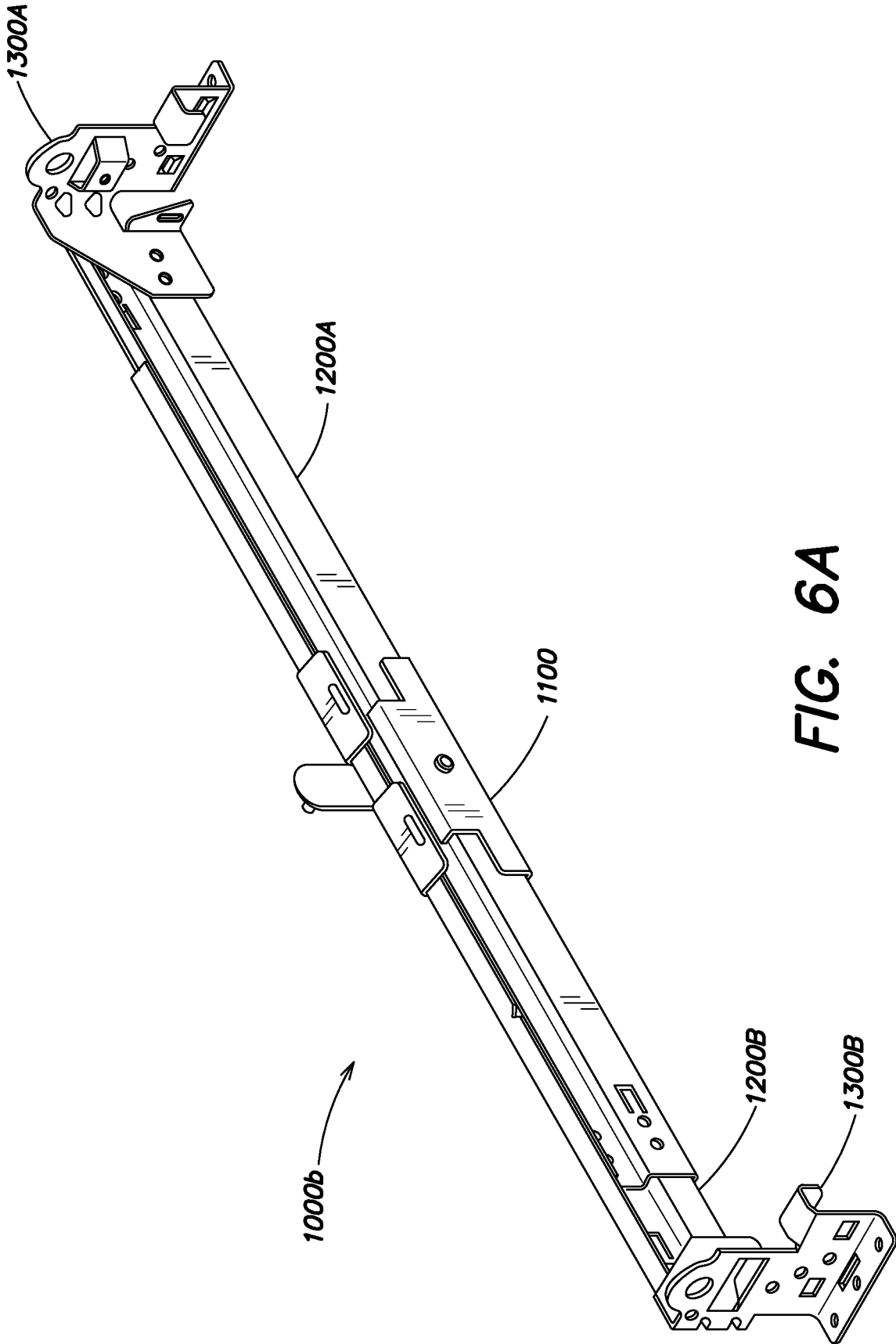


FIG. 6A



14/77

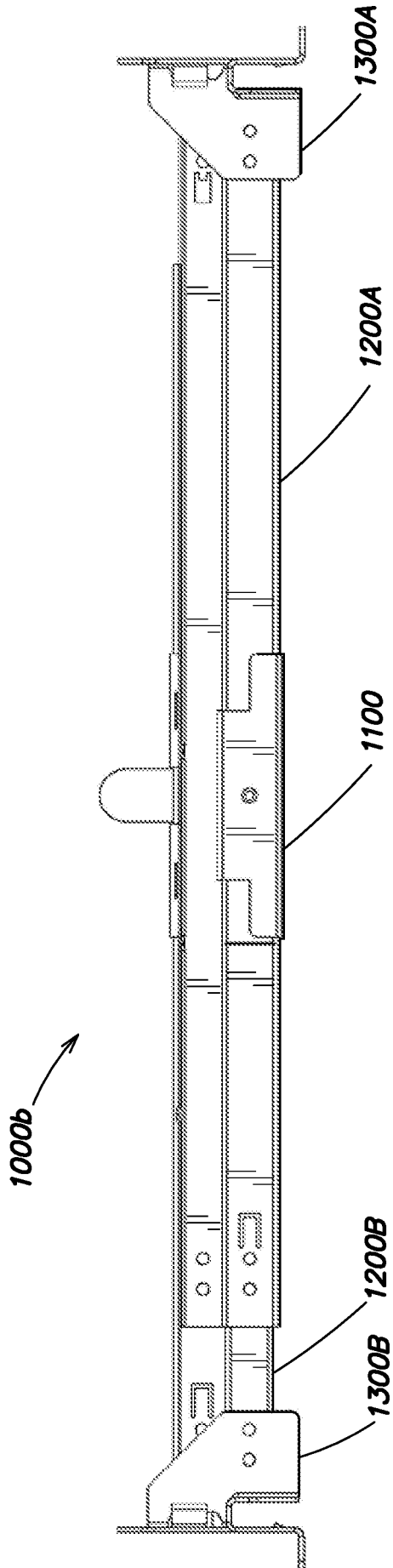
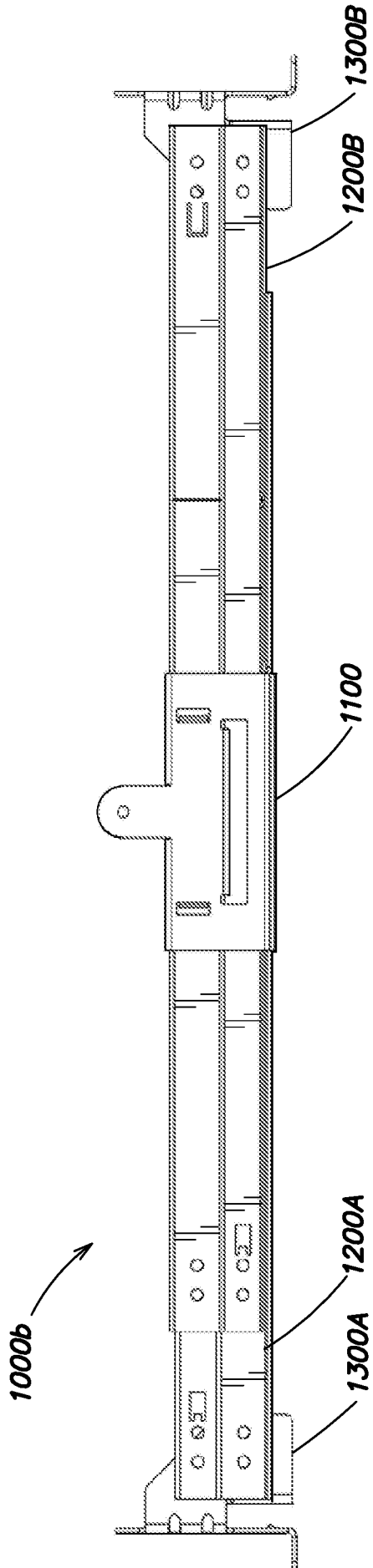
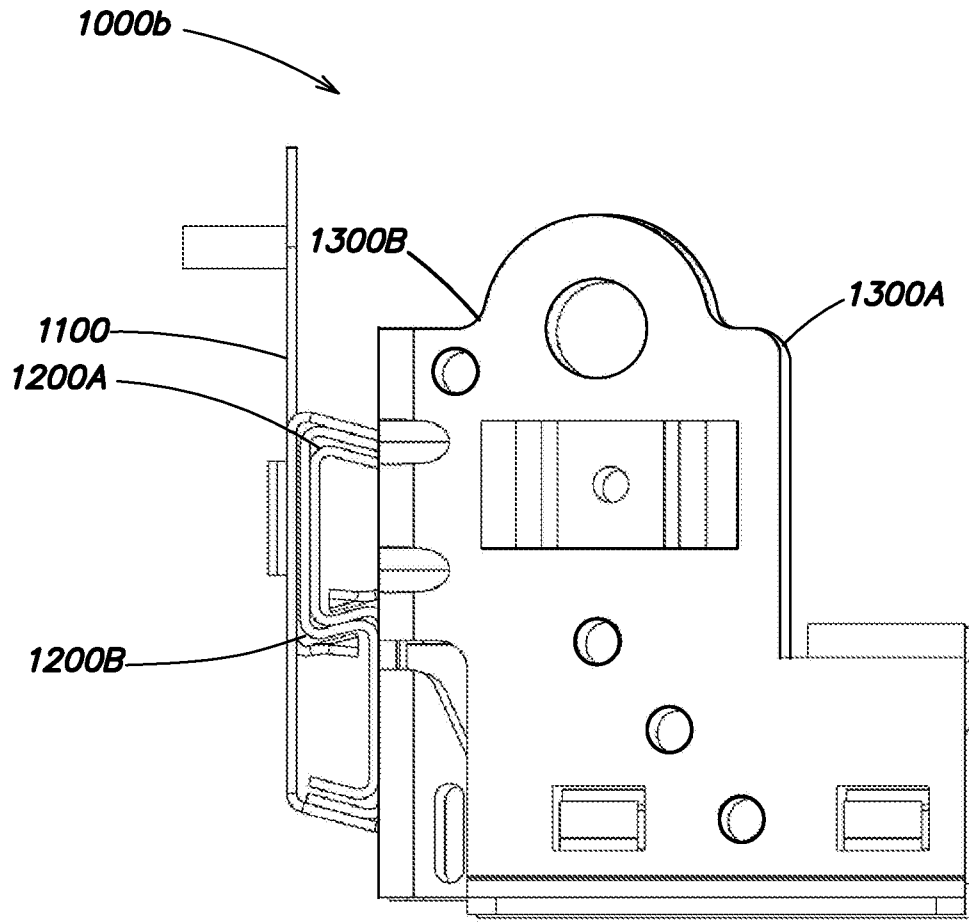


FIG. 6B

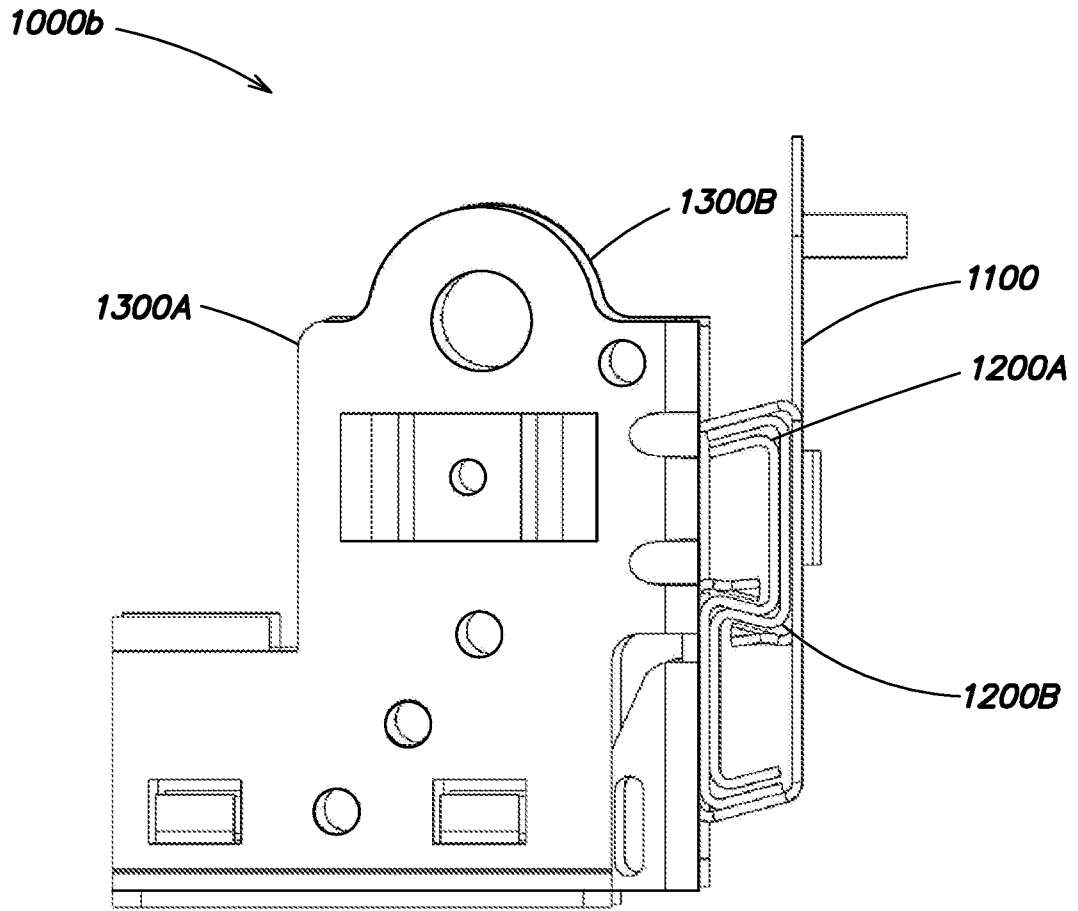


**FIG. 6C**



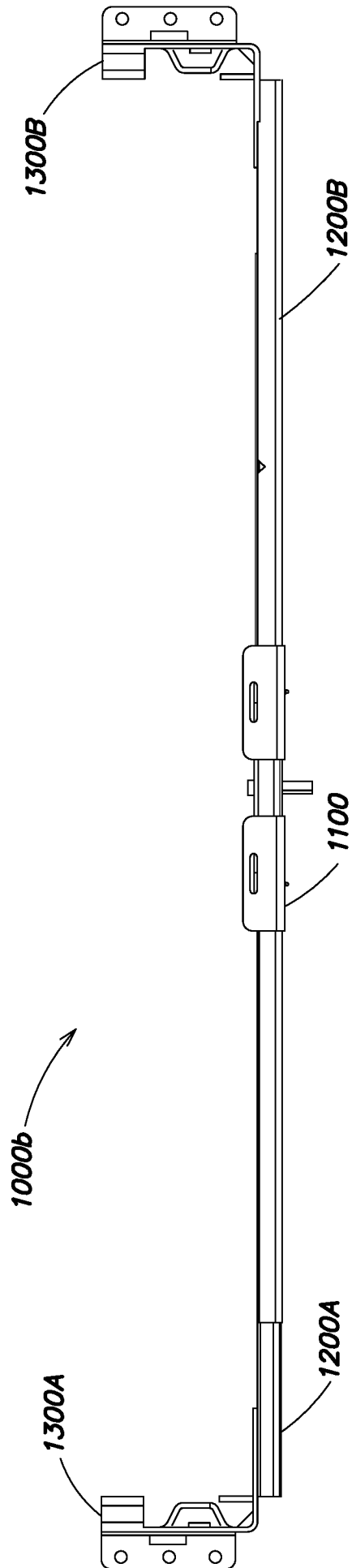
**FIG. 6D**

17/77

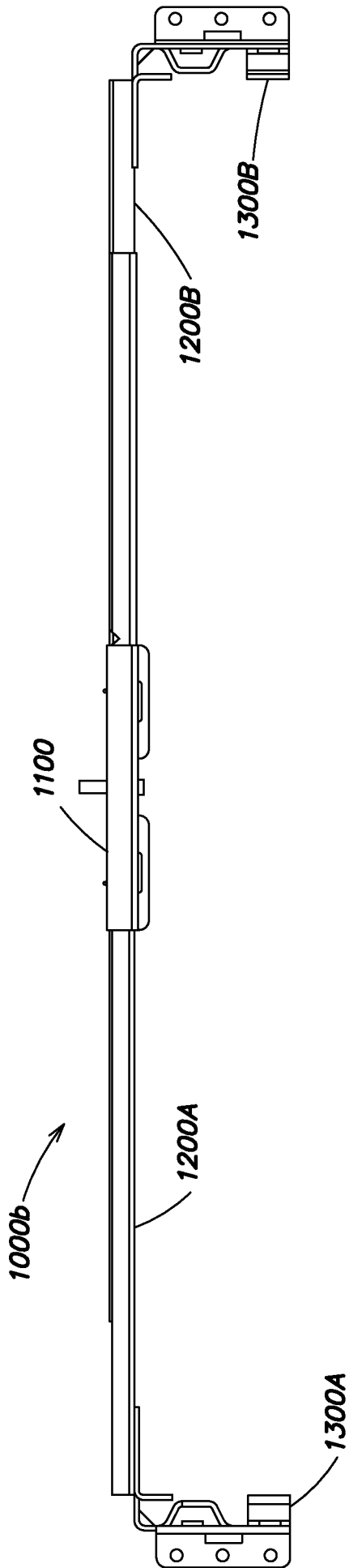


**FIG. 6E**

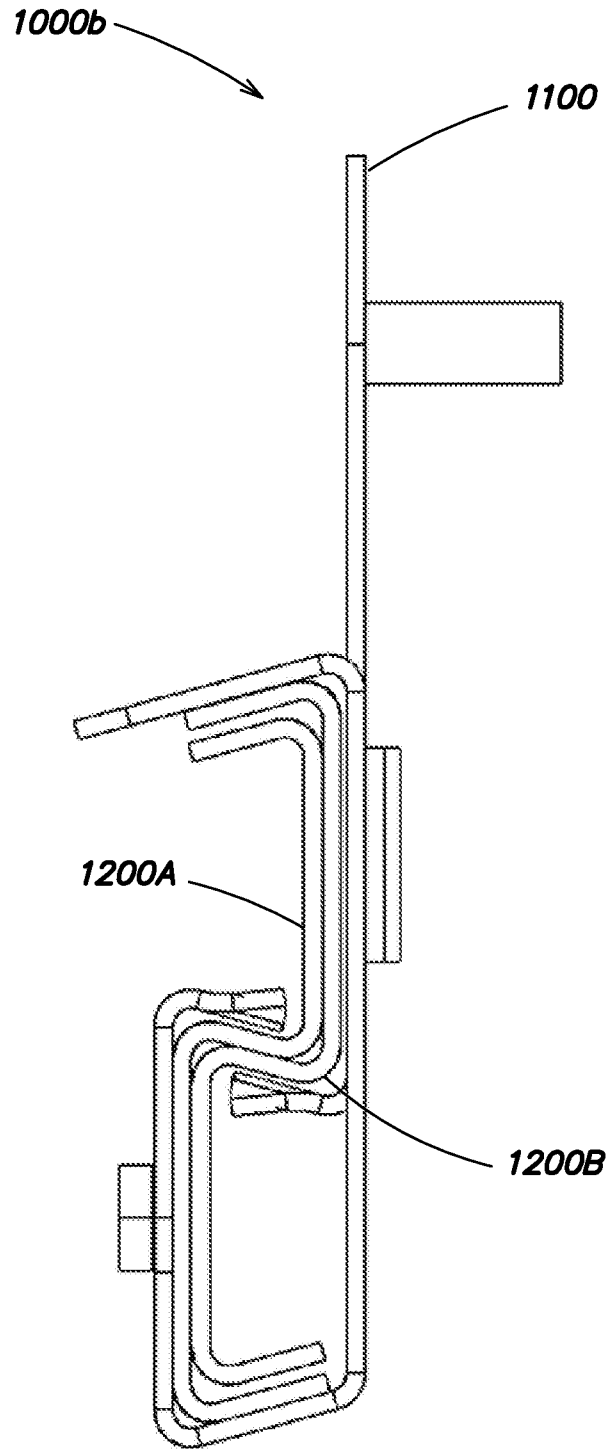
18/77



**FIG. 6F**



**FIG. 6G**



**FIG. 6H**

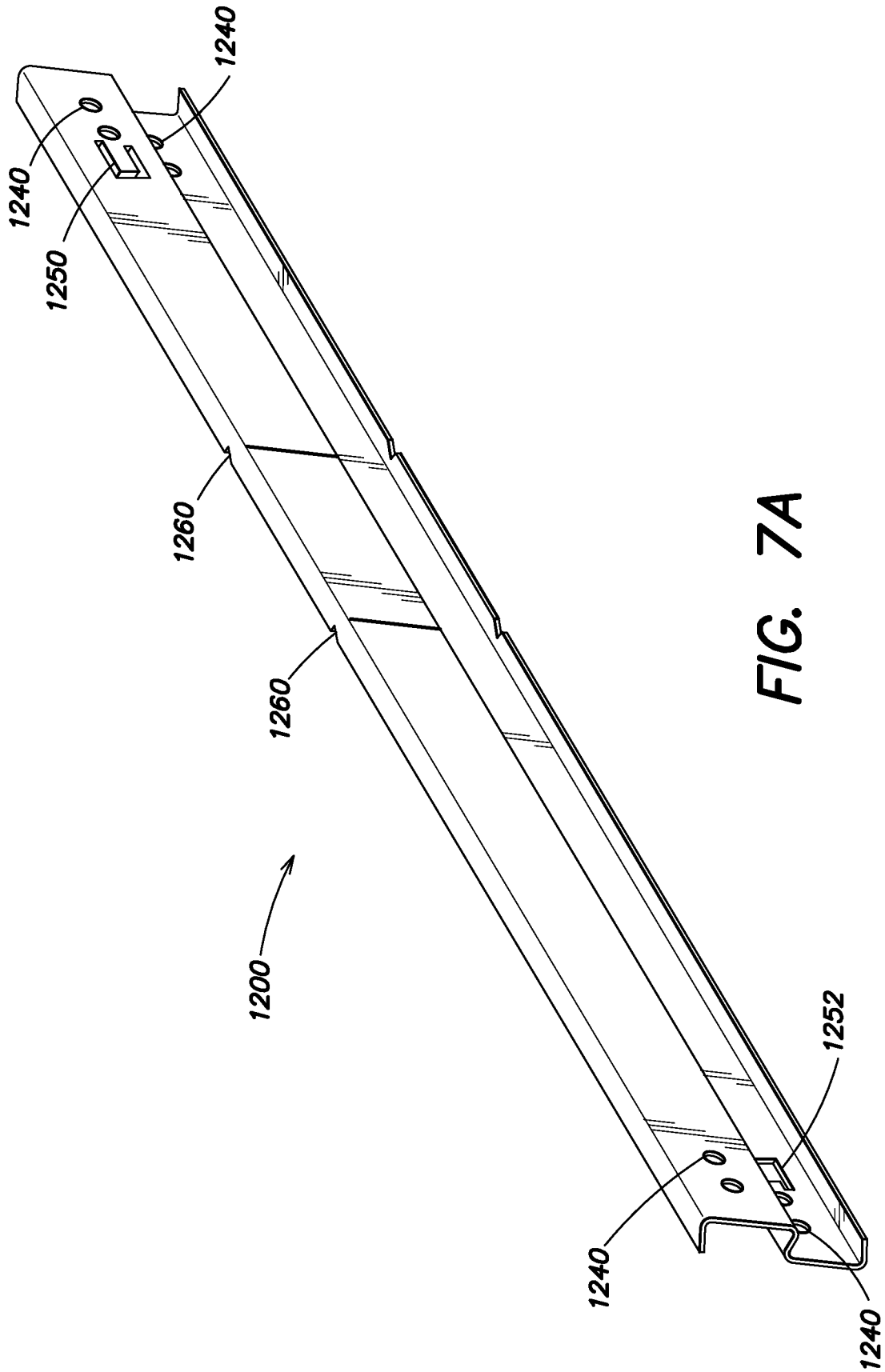
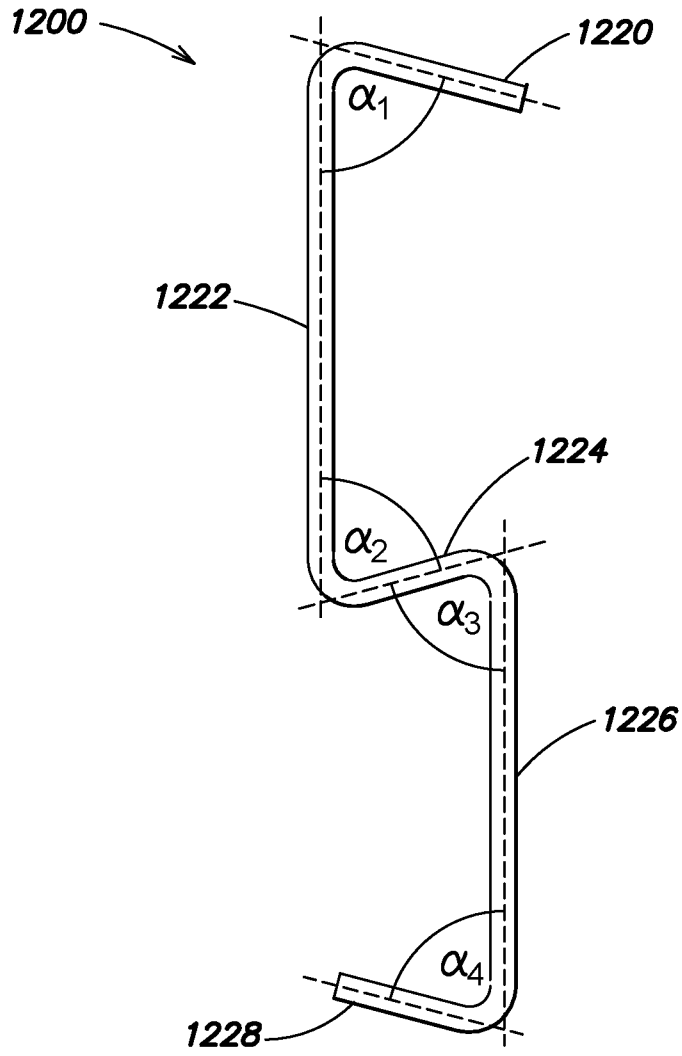


FIG. 7A





**FIG. 7B**

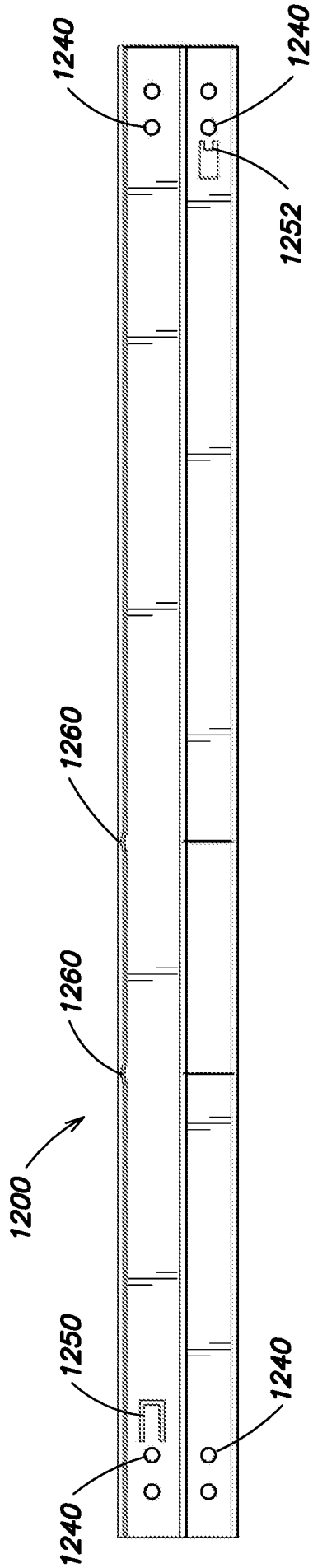


FIG. 7C

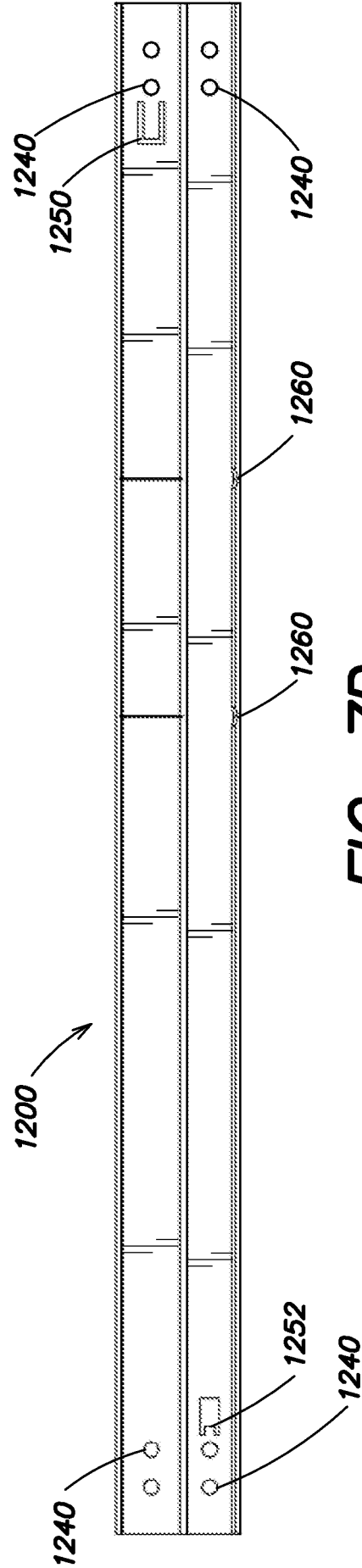
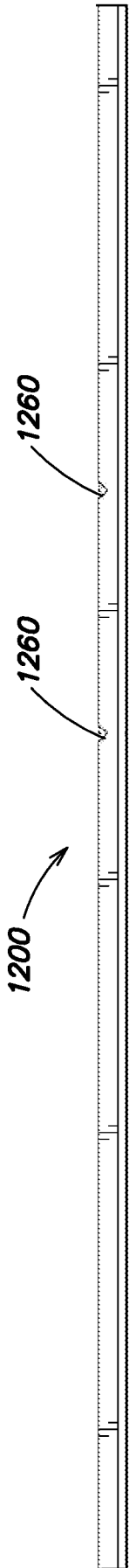
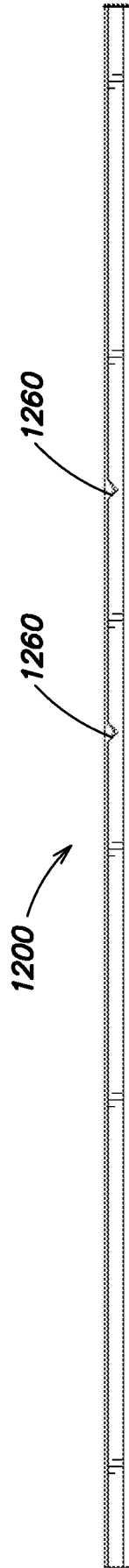


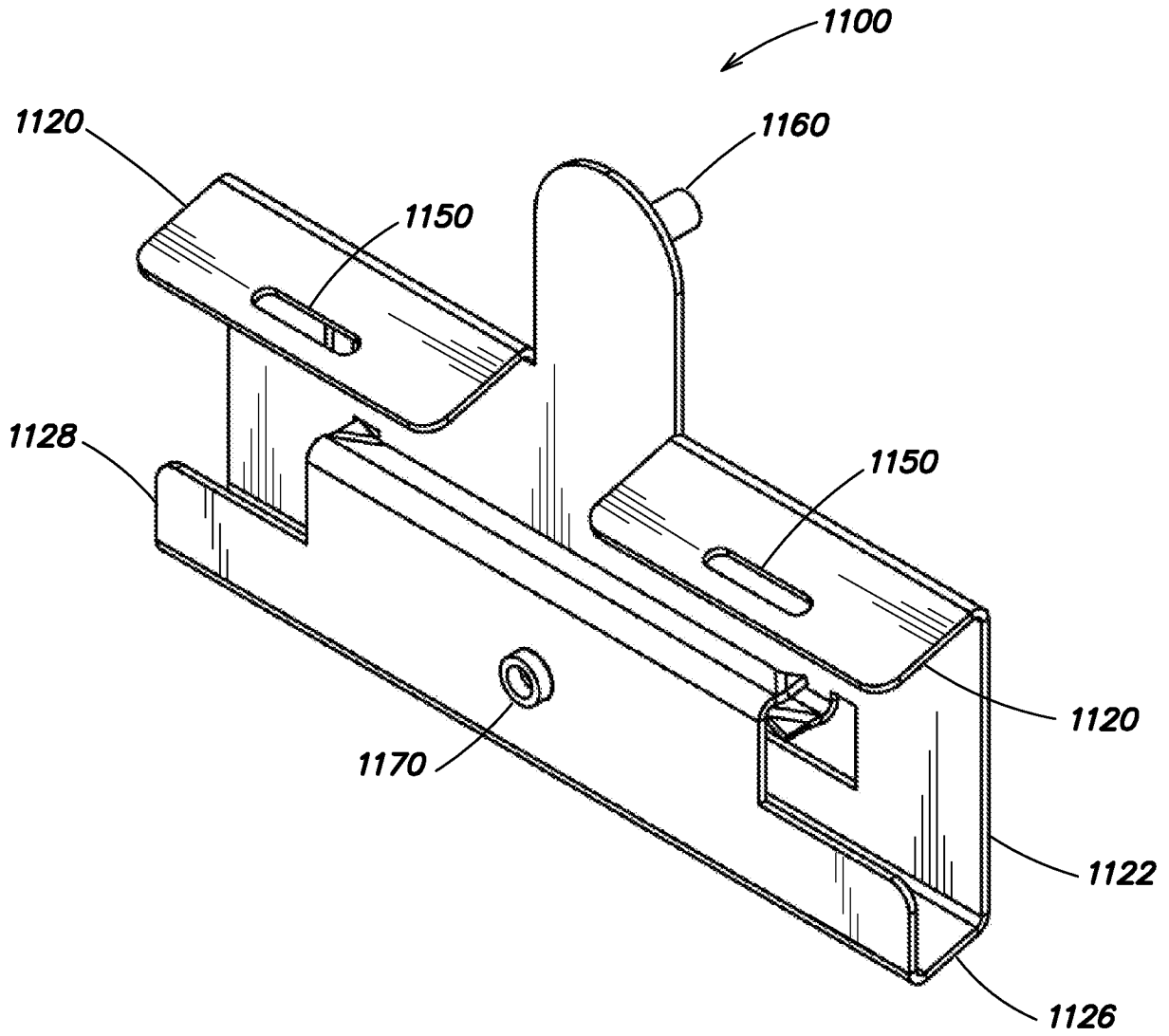
FIG. 7D



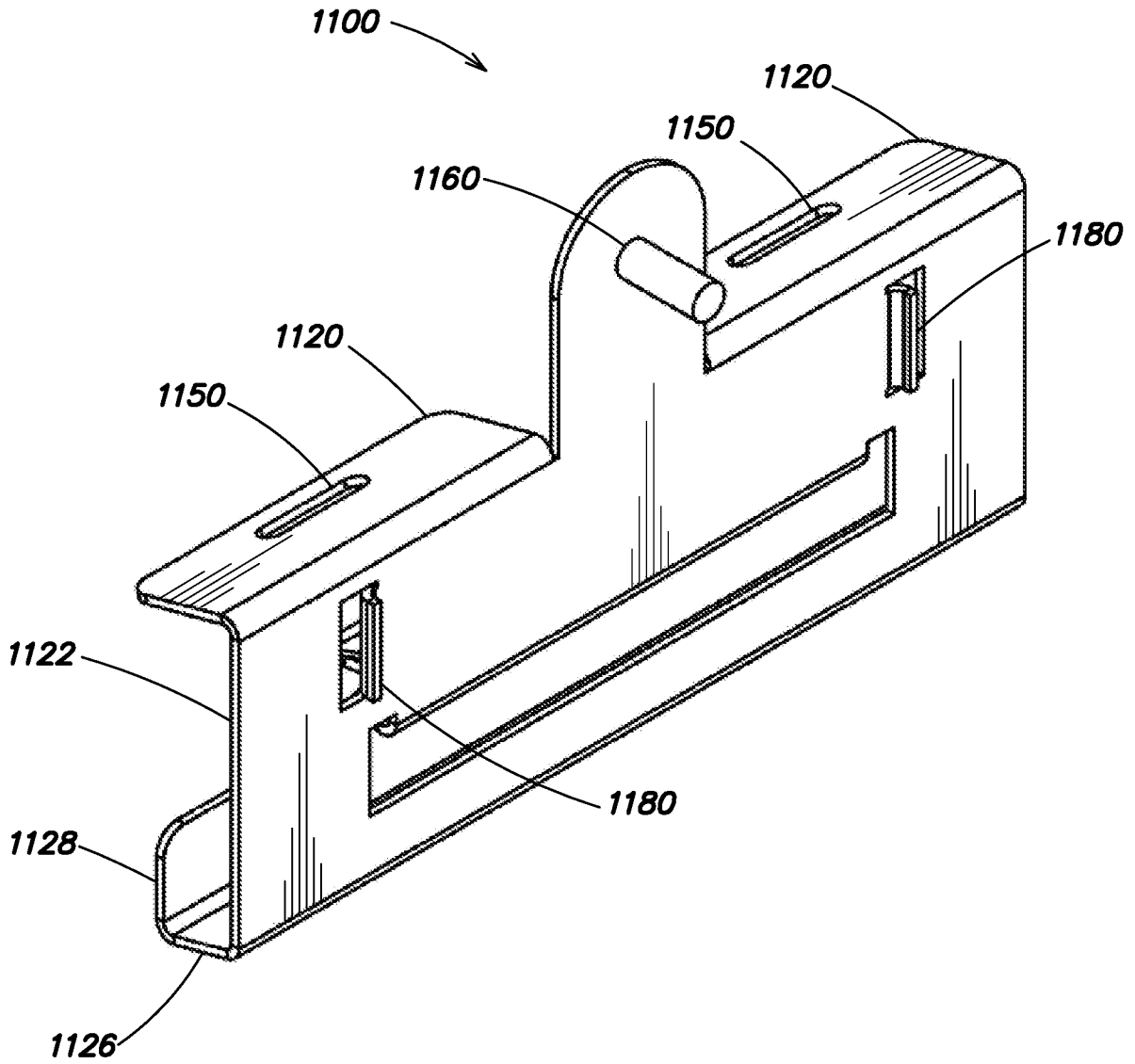
**FIG. 7E**



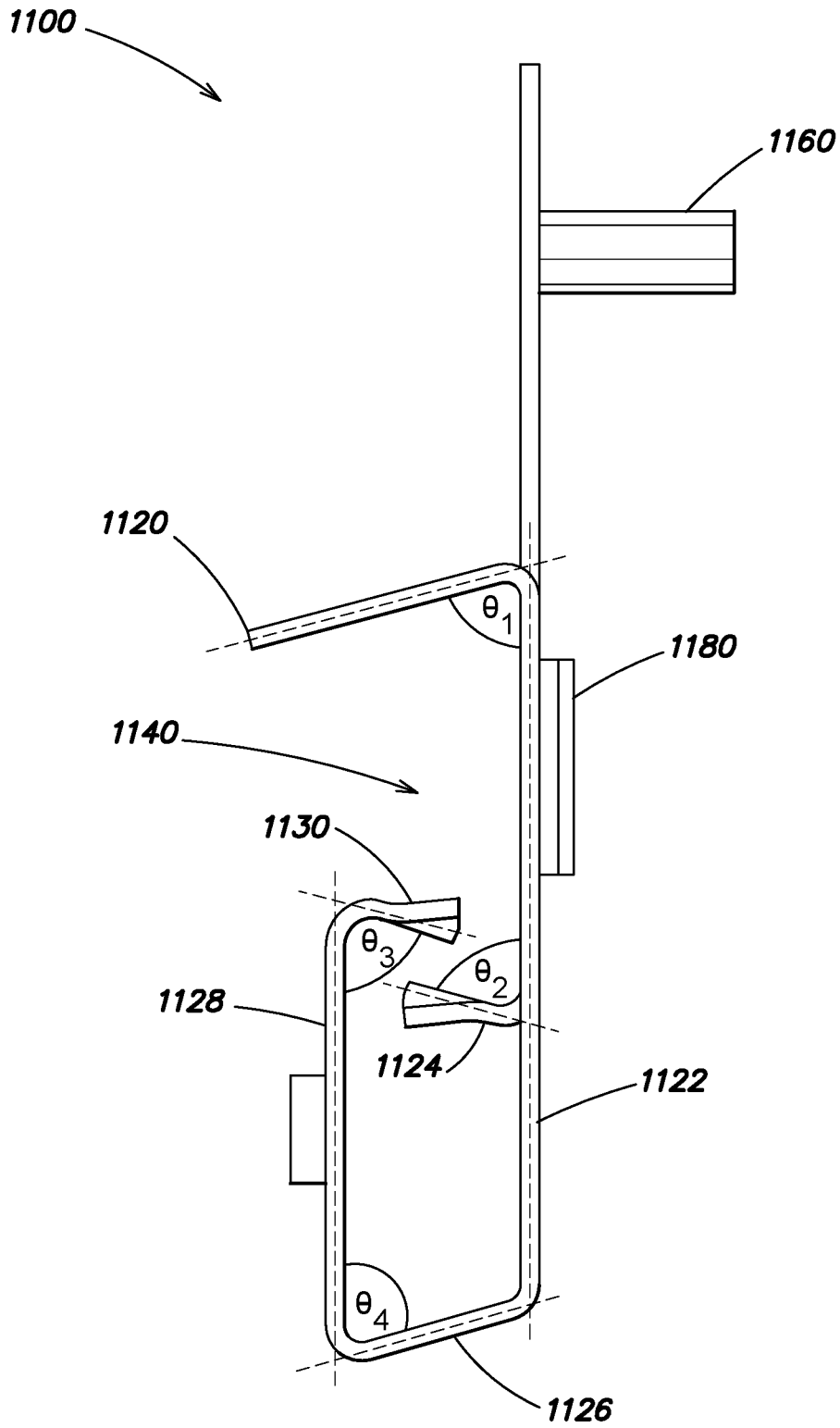
**FIG. 7F**



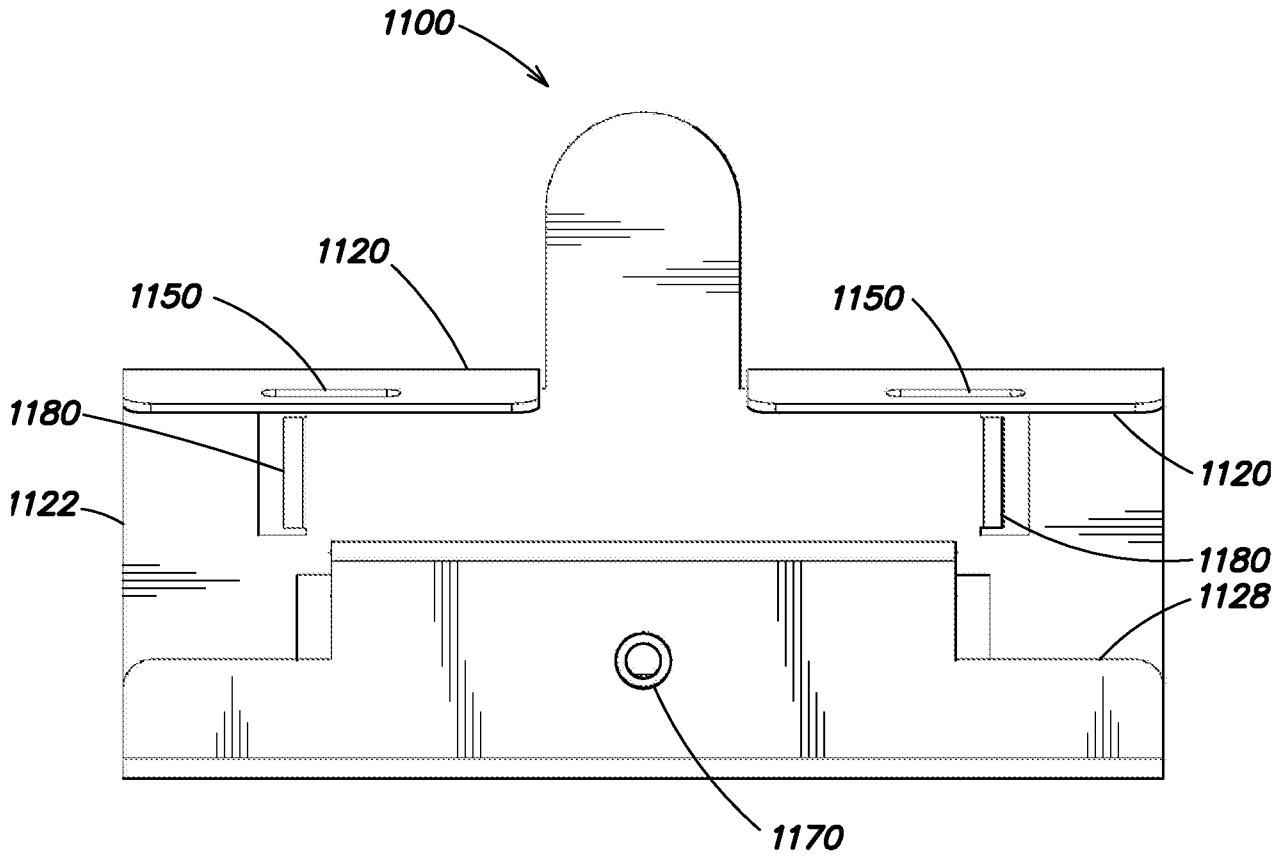
**FIG. 8A**



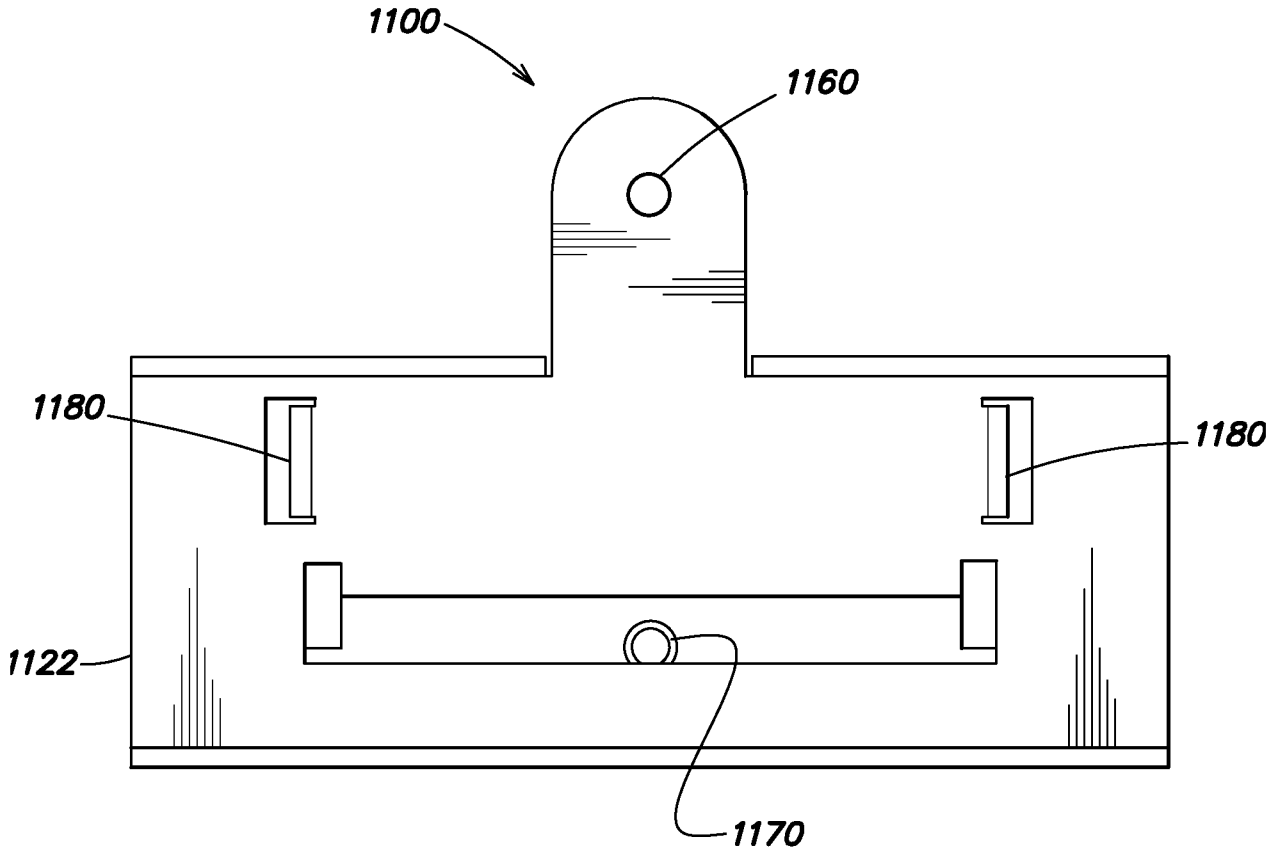
**FIG. 8B**



**FIG. 8C**



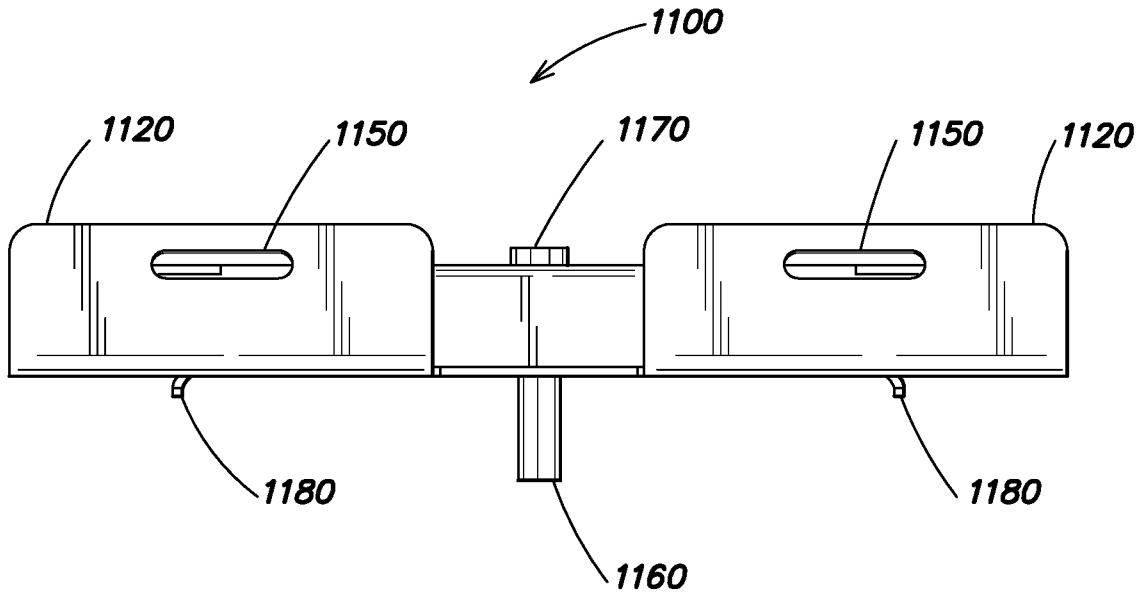
**FIG. 8D**



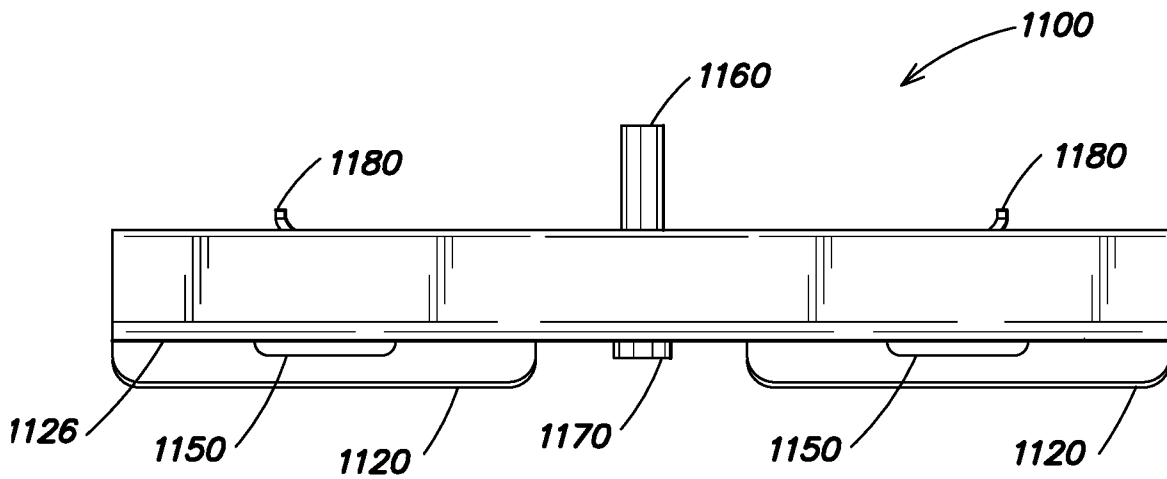
**FIG. 8E**



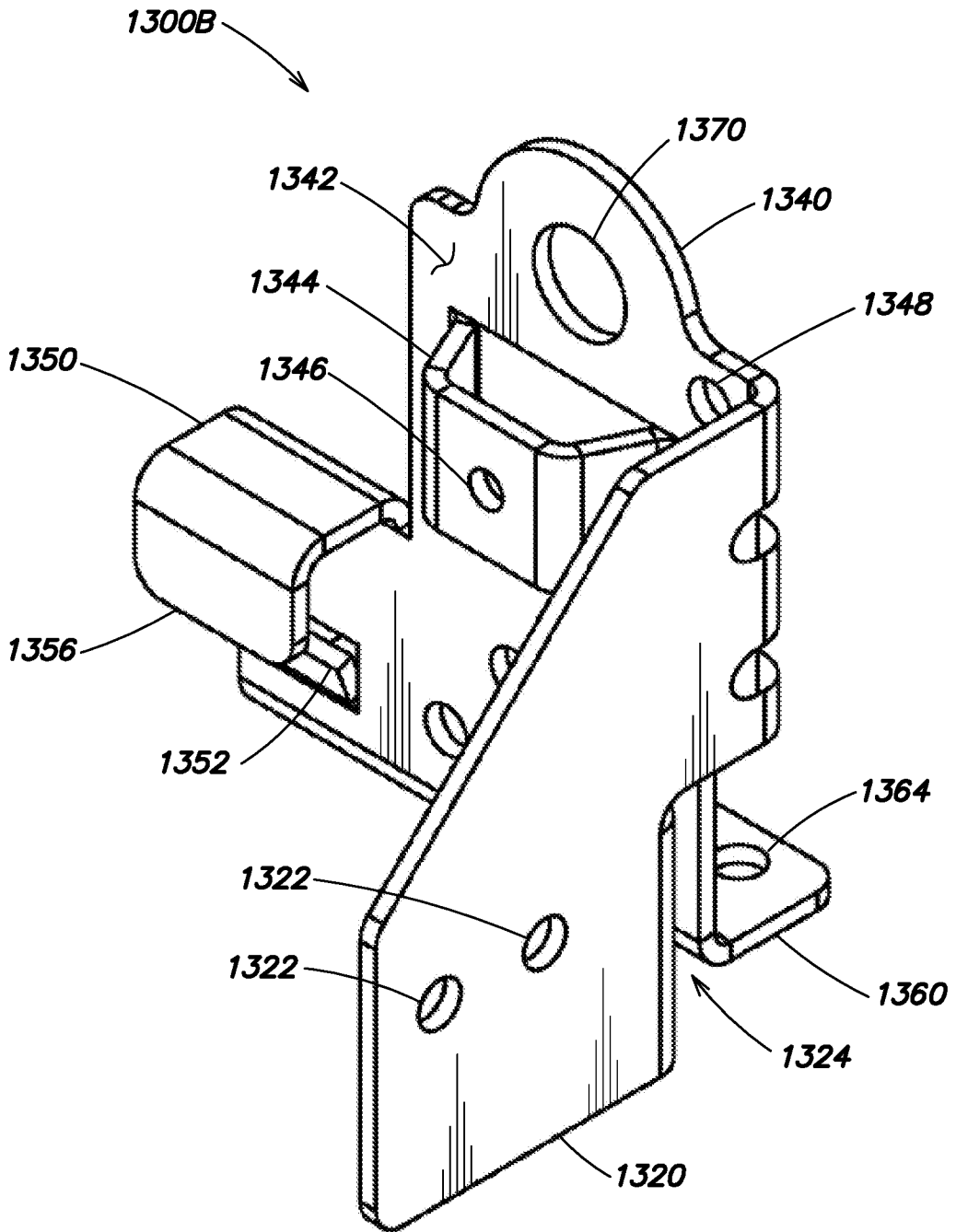
30/77



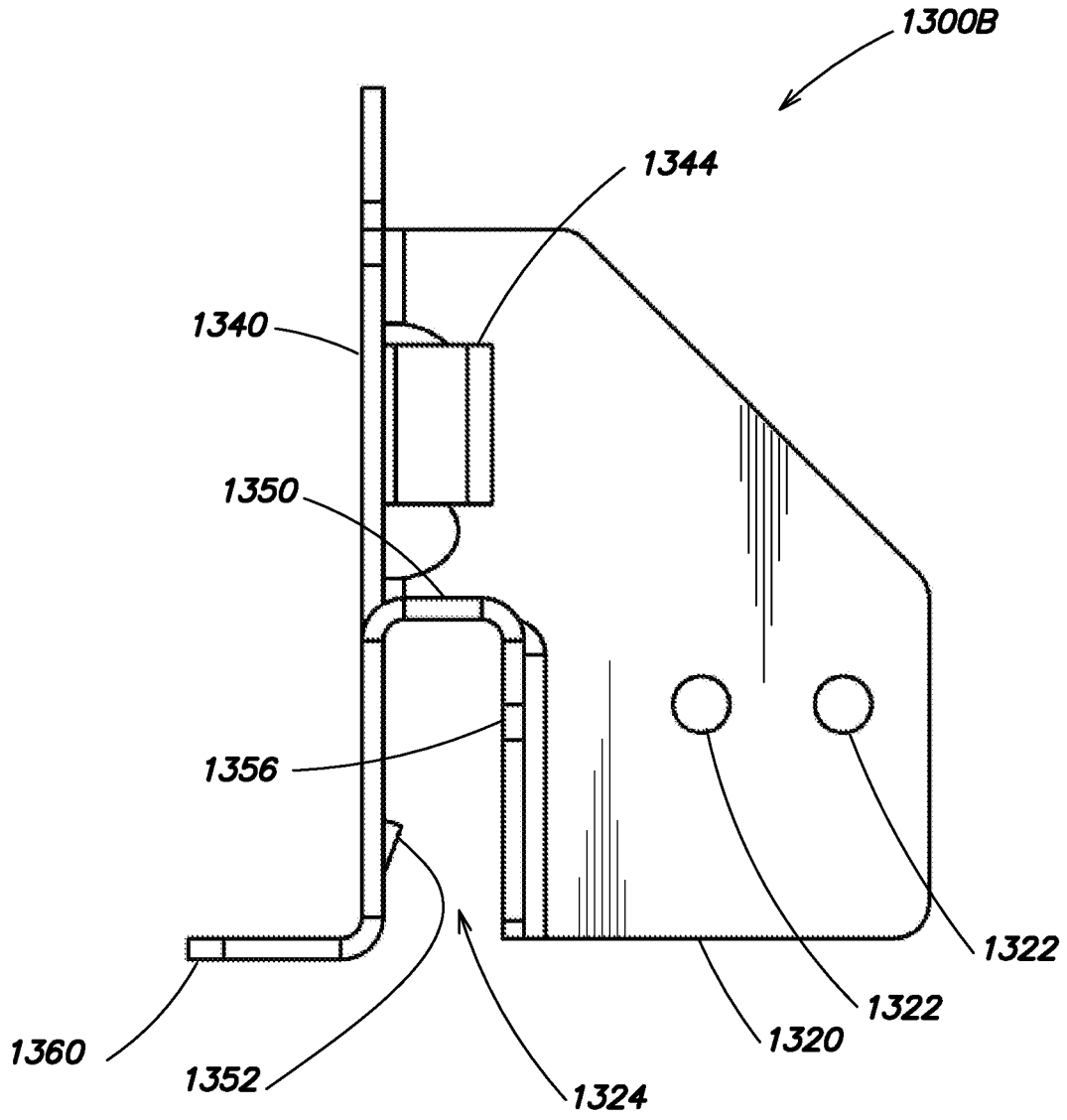
**FIG. 8F**



**FIG. 8G**

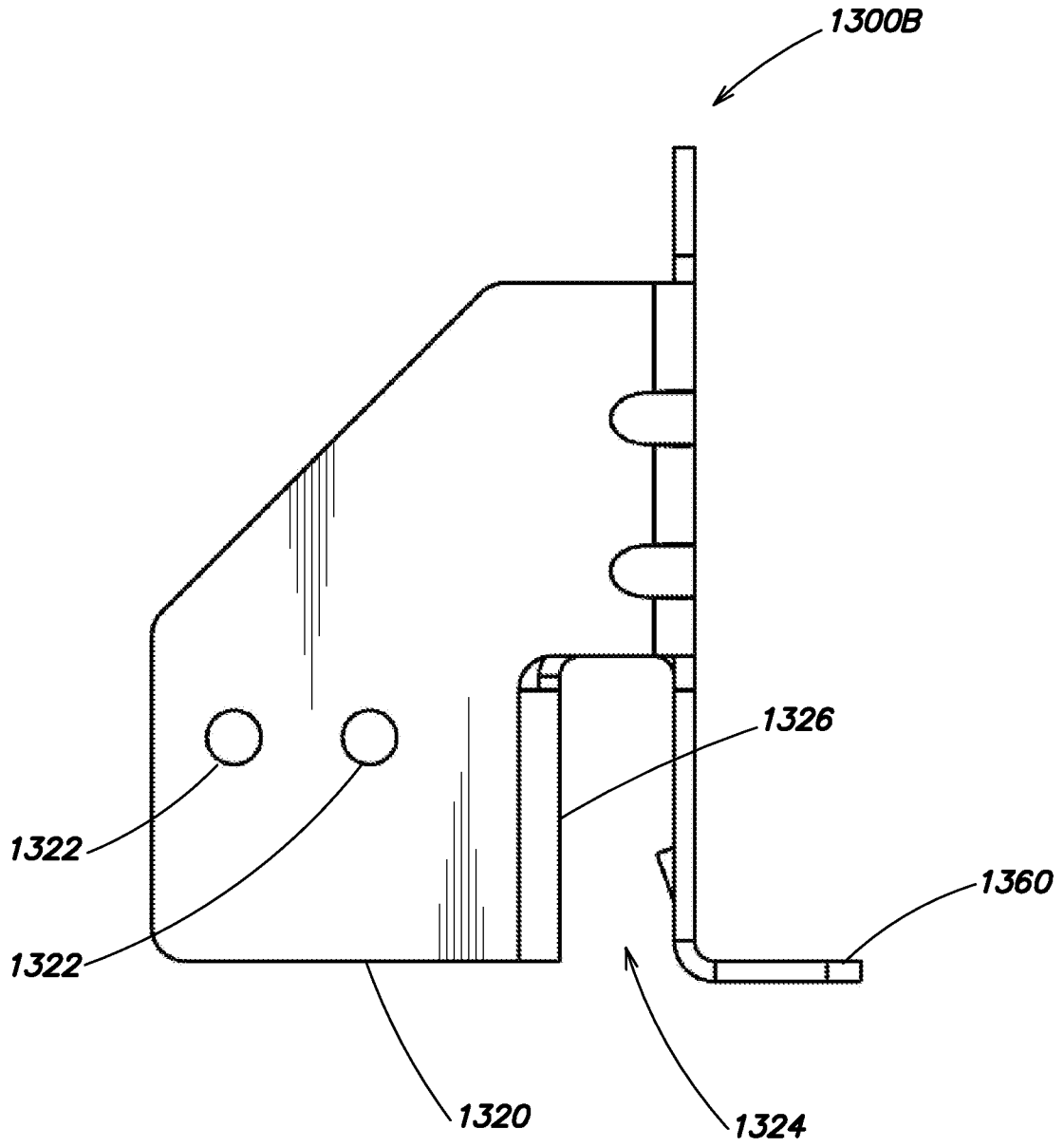


**FIG. 9A**



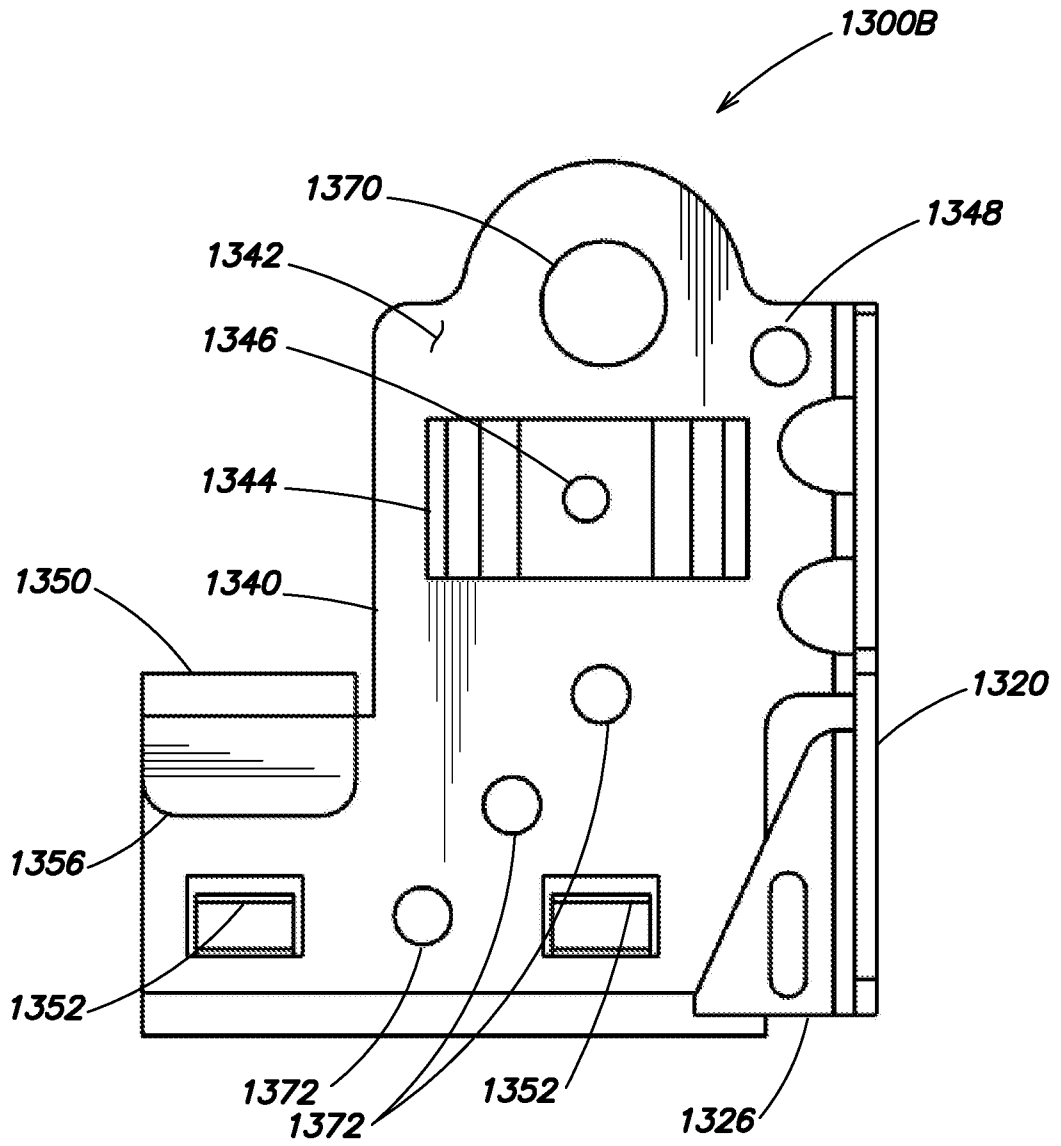
**FIG. 9B**

33/77

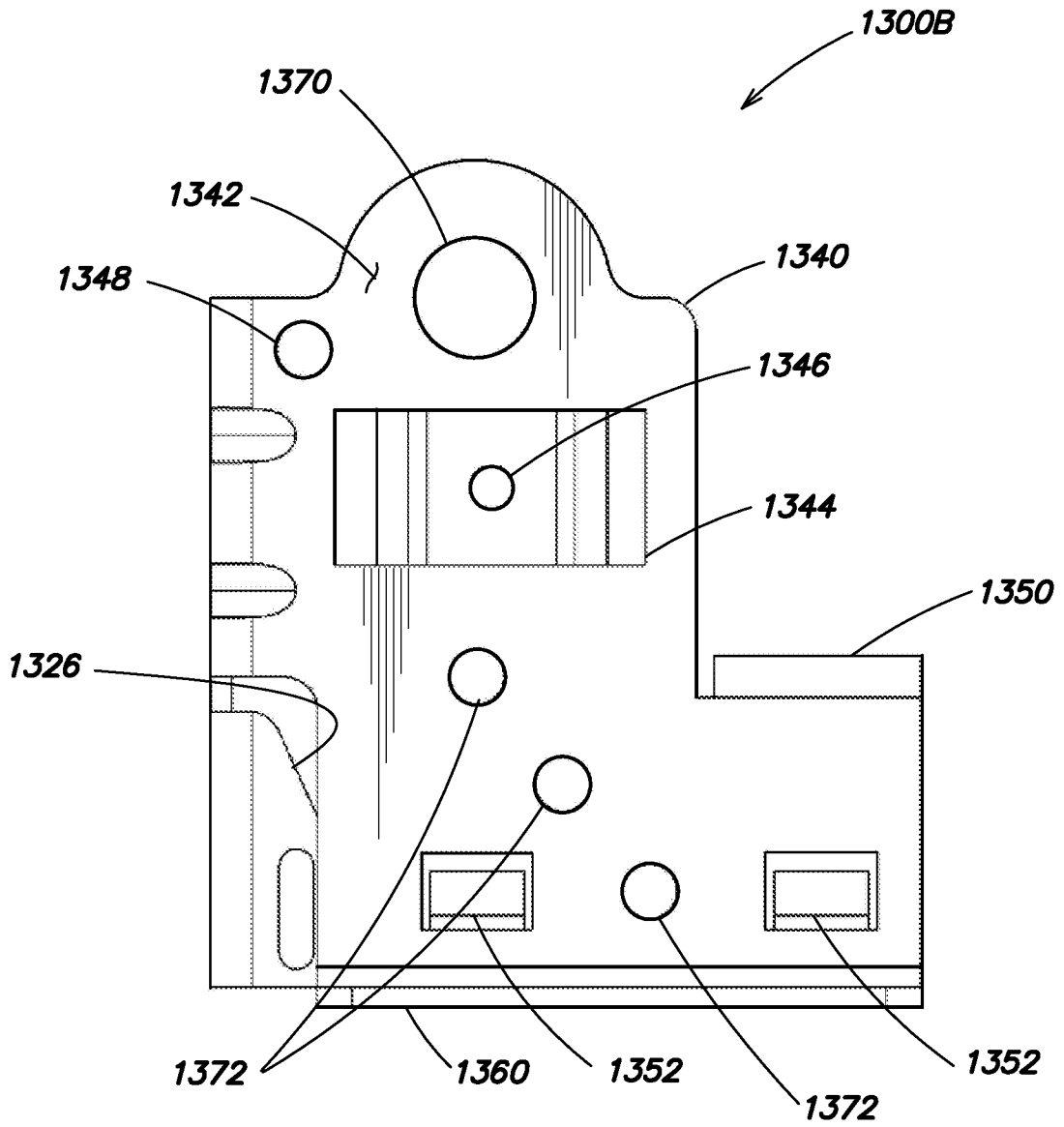


**FIG. 9C**

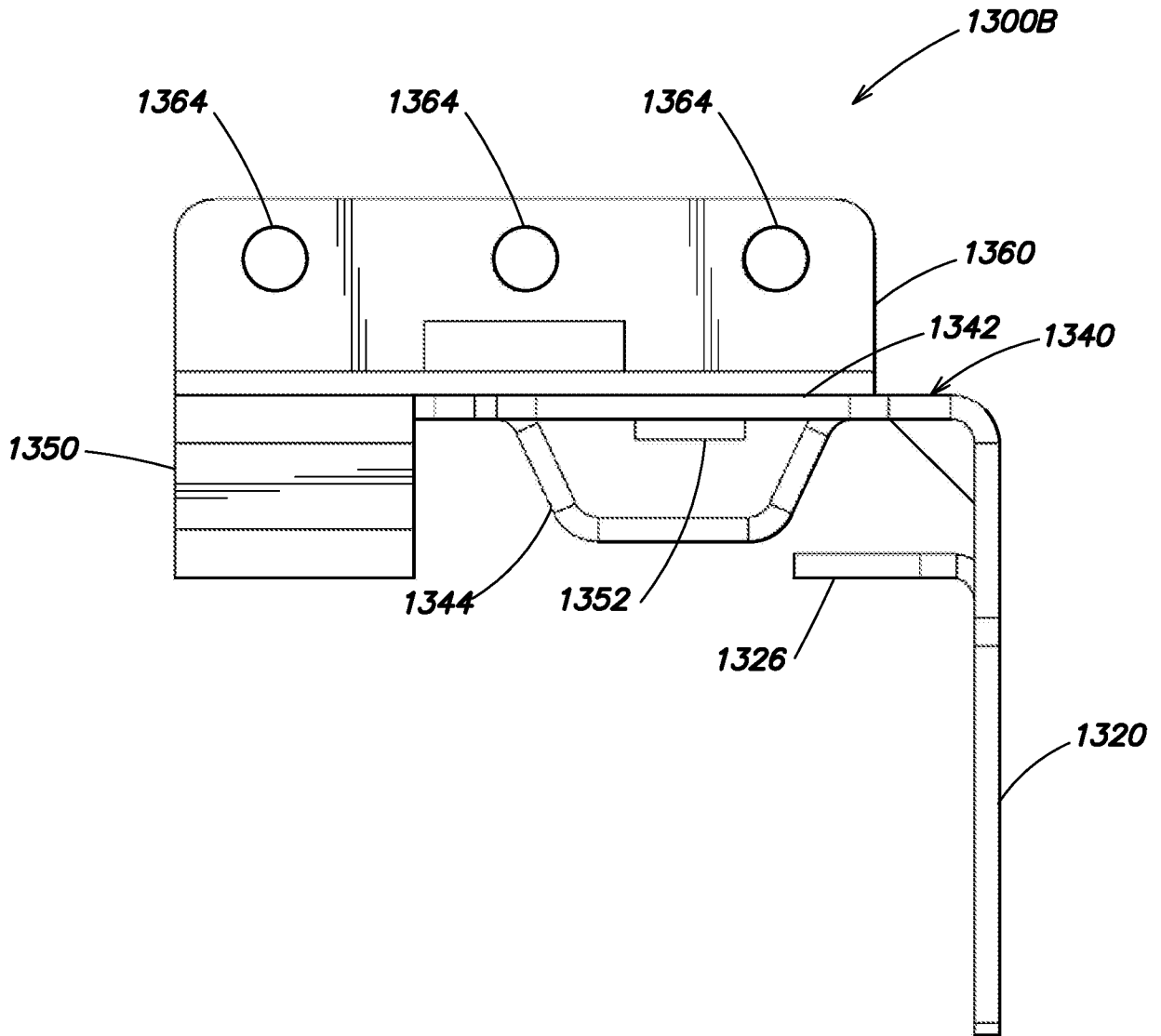
34/77



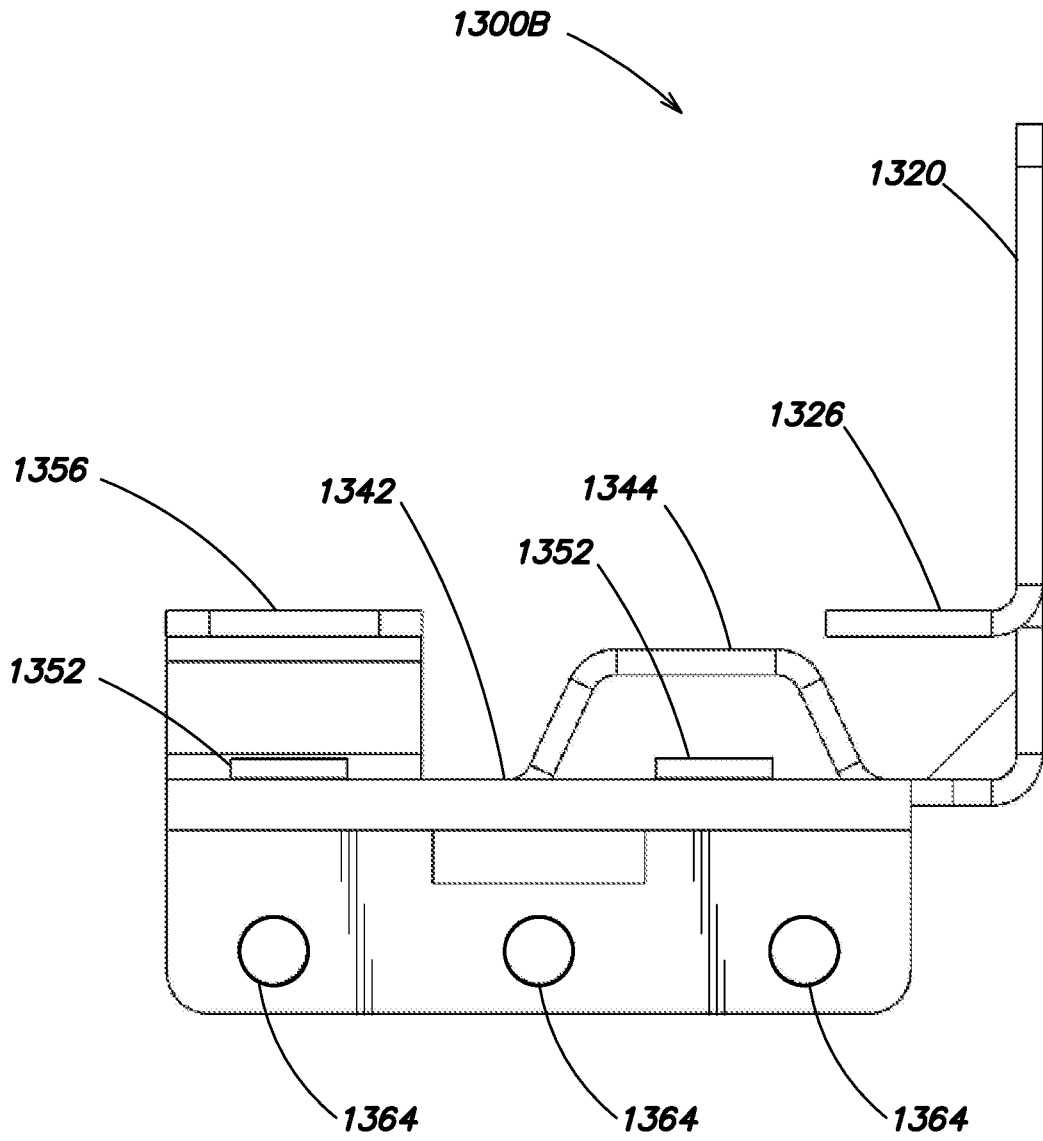
**FIG. 9D**



**FIG. 9E**

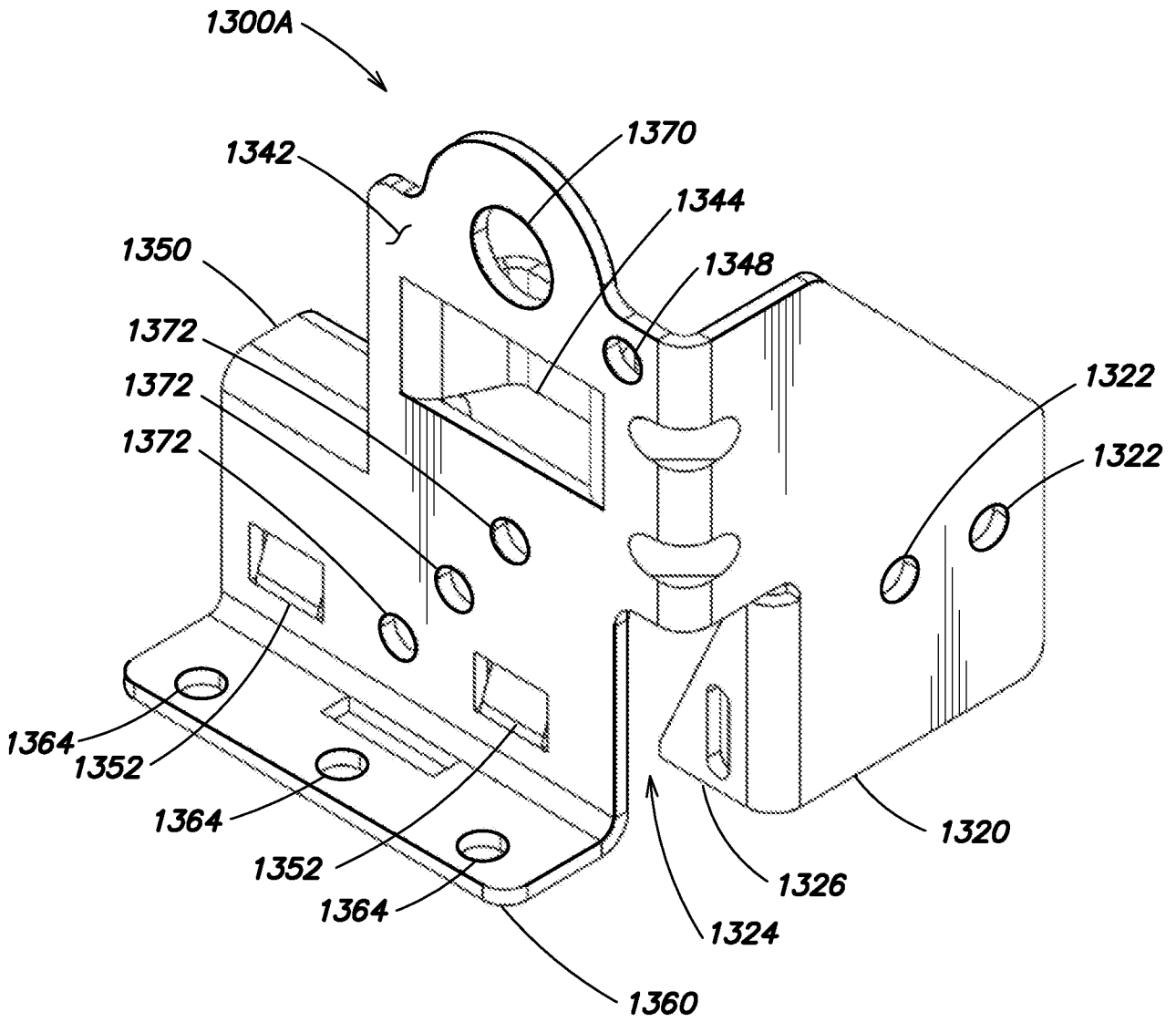


**FIG. 9F**

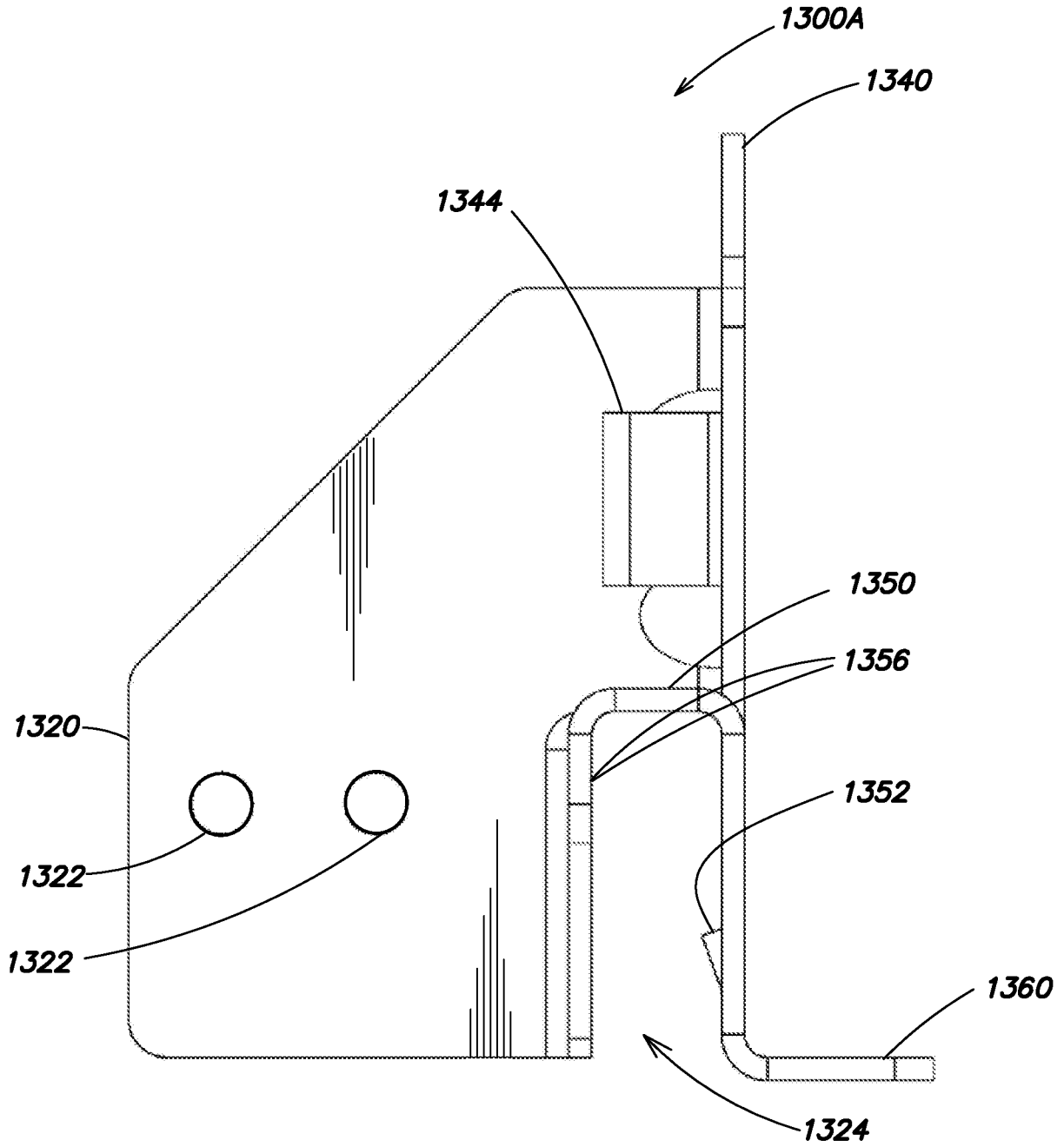


**FIG. 9G**



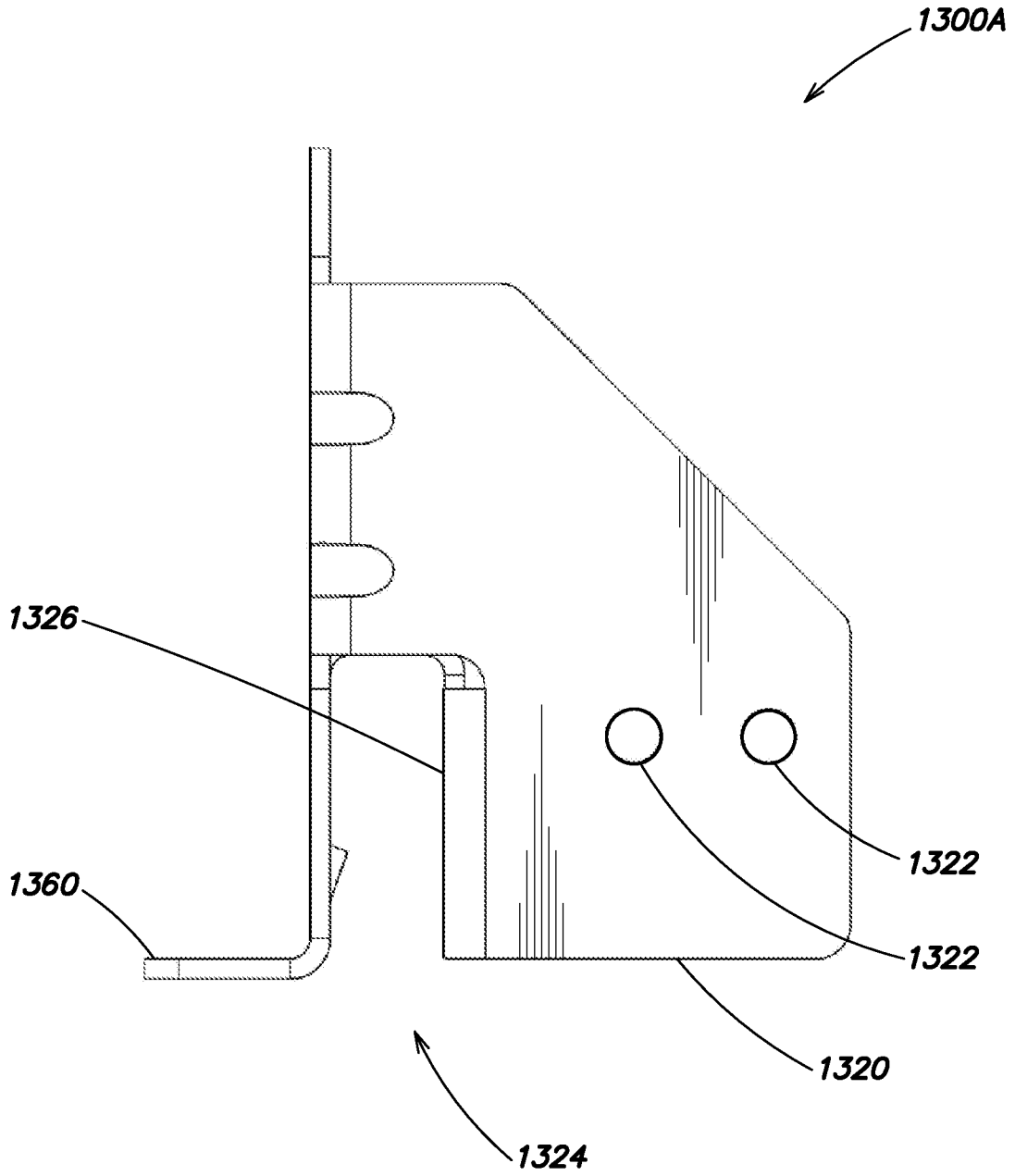


**FIG. 10A**



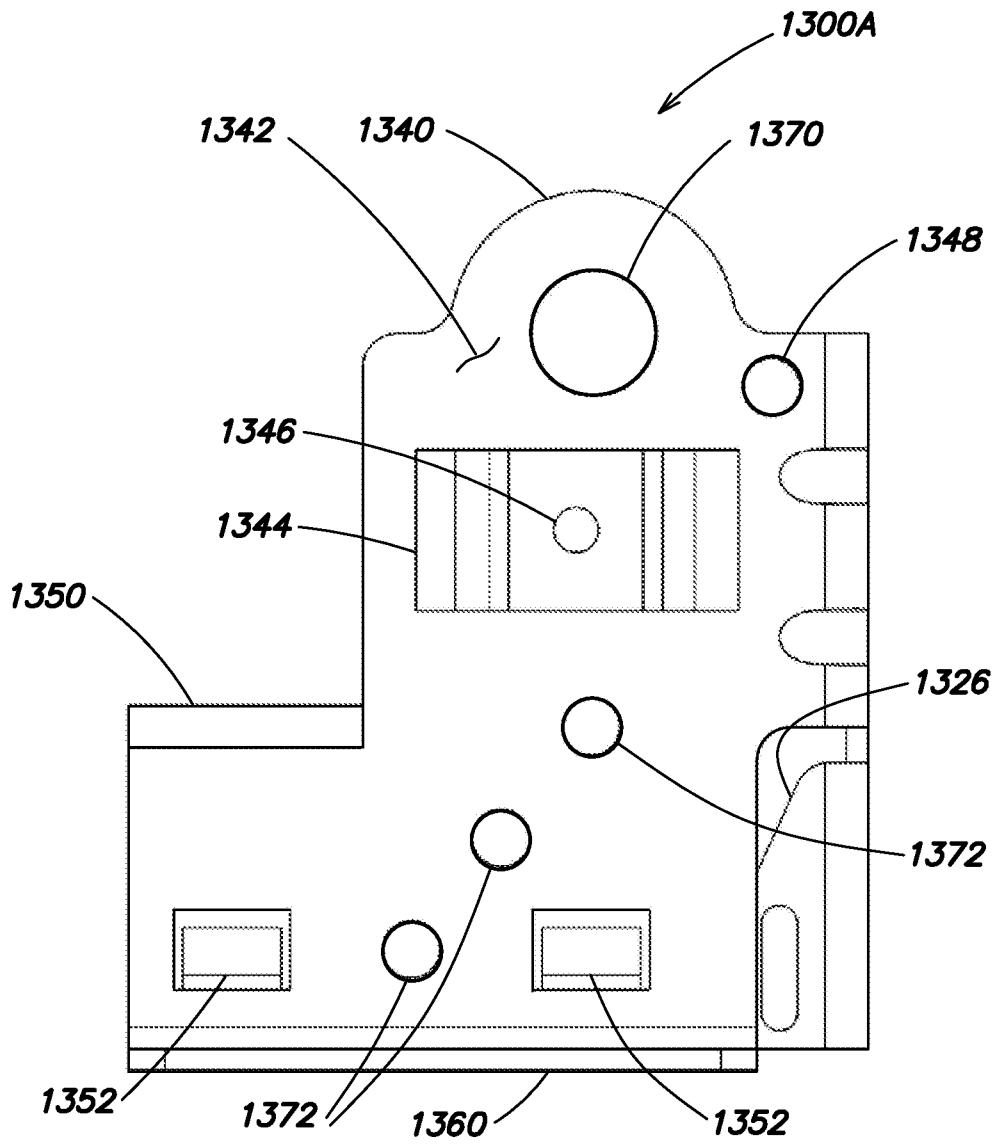
**FIG. 10B**

40/77



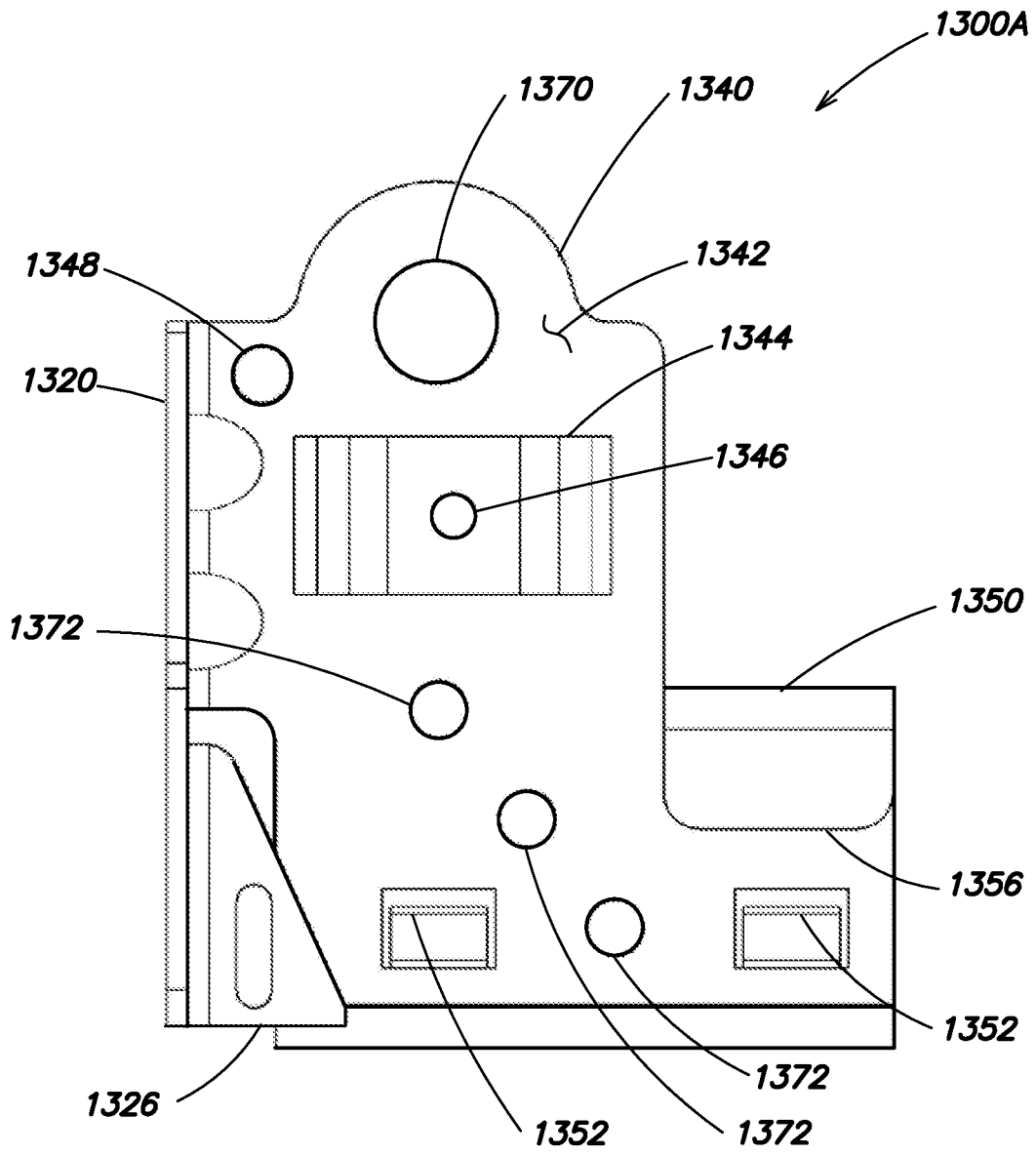
**FIG. 10C**

41/77



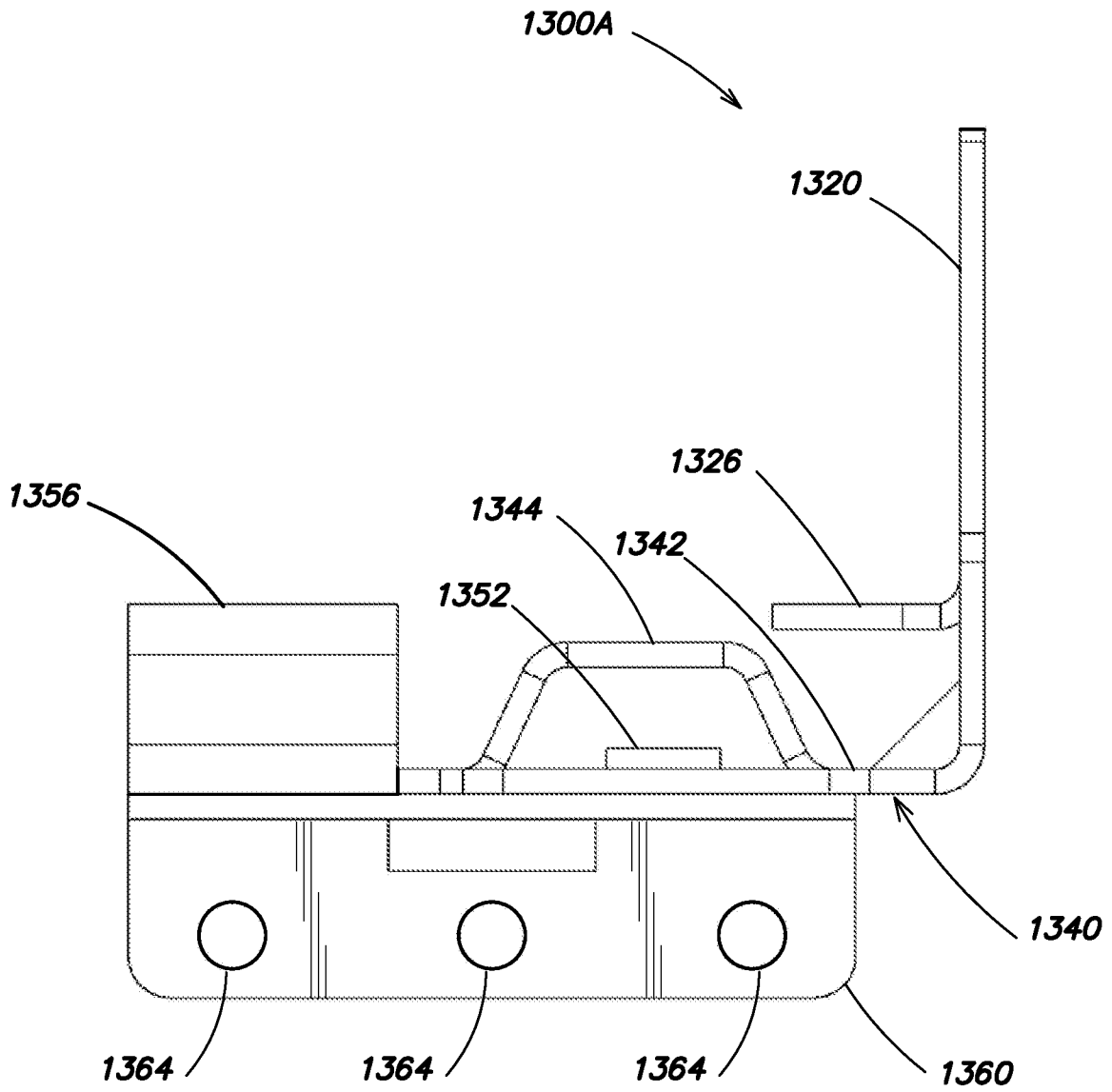
**FIG. 10D**

42/77

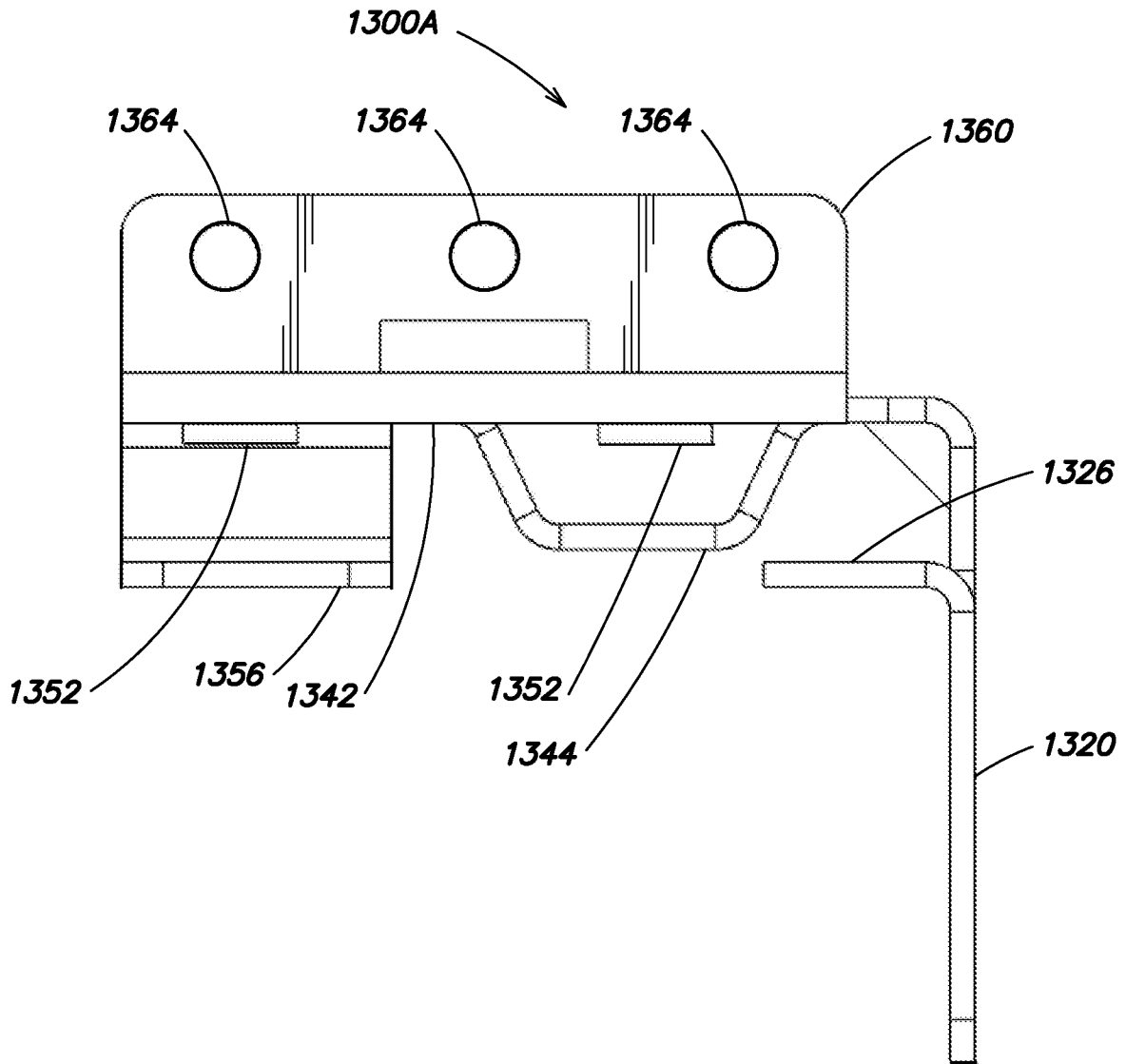


**FIG. 10E**

43/77



**FIG. 10F**



**FIG. 10G**

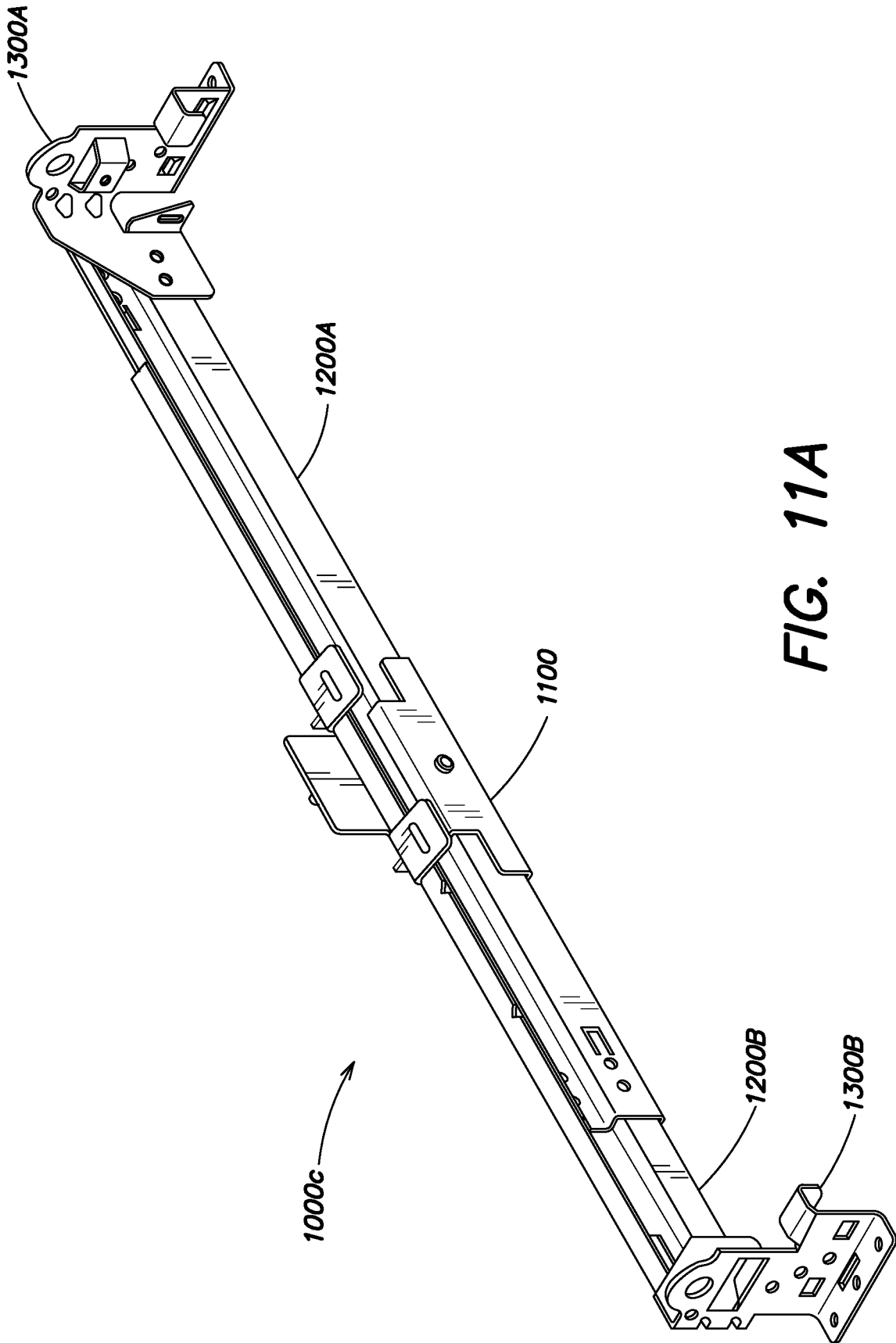


FIG. 11A



46/77

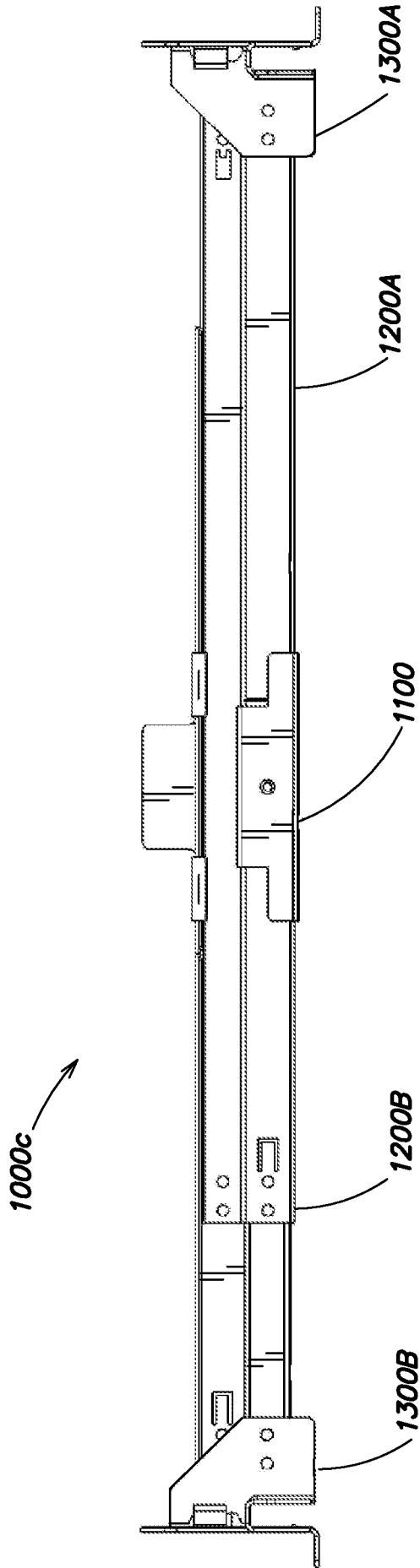


FIG. 11B

47/77

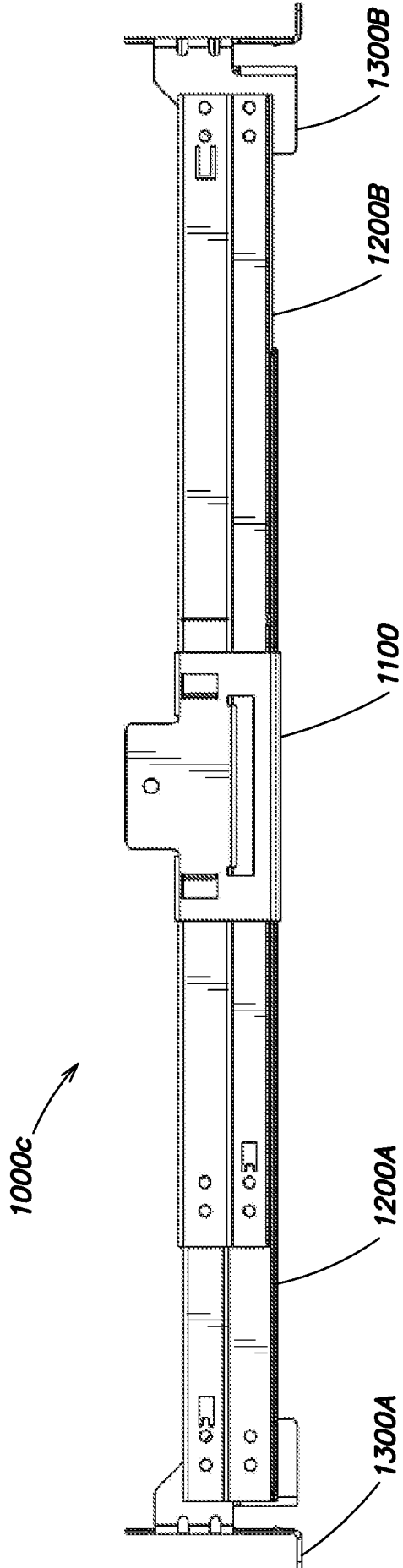
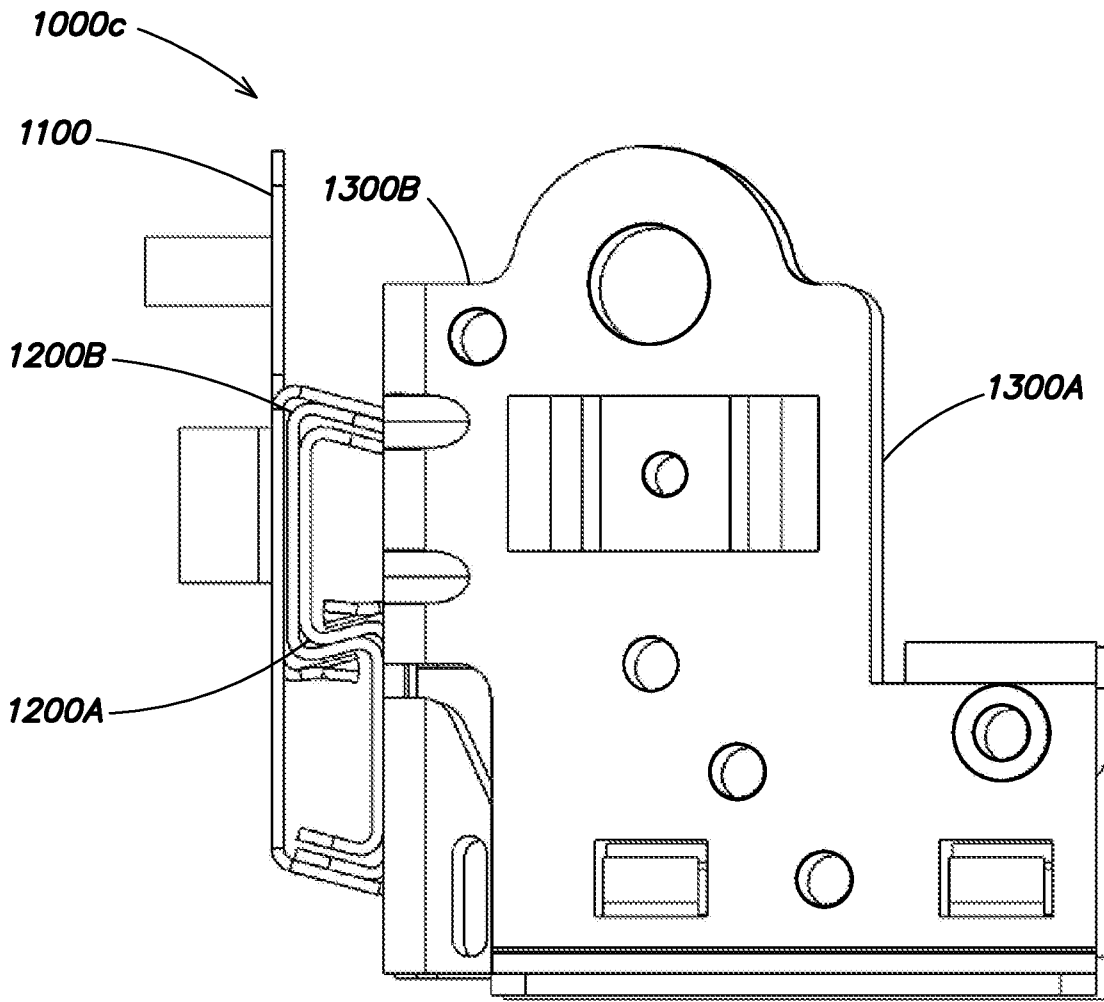
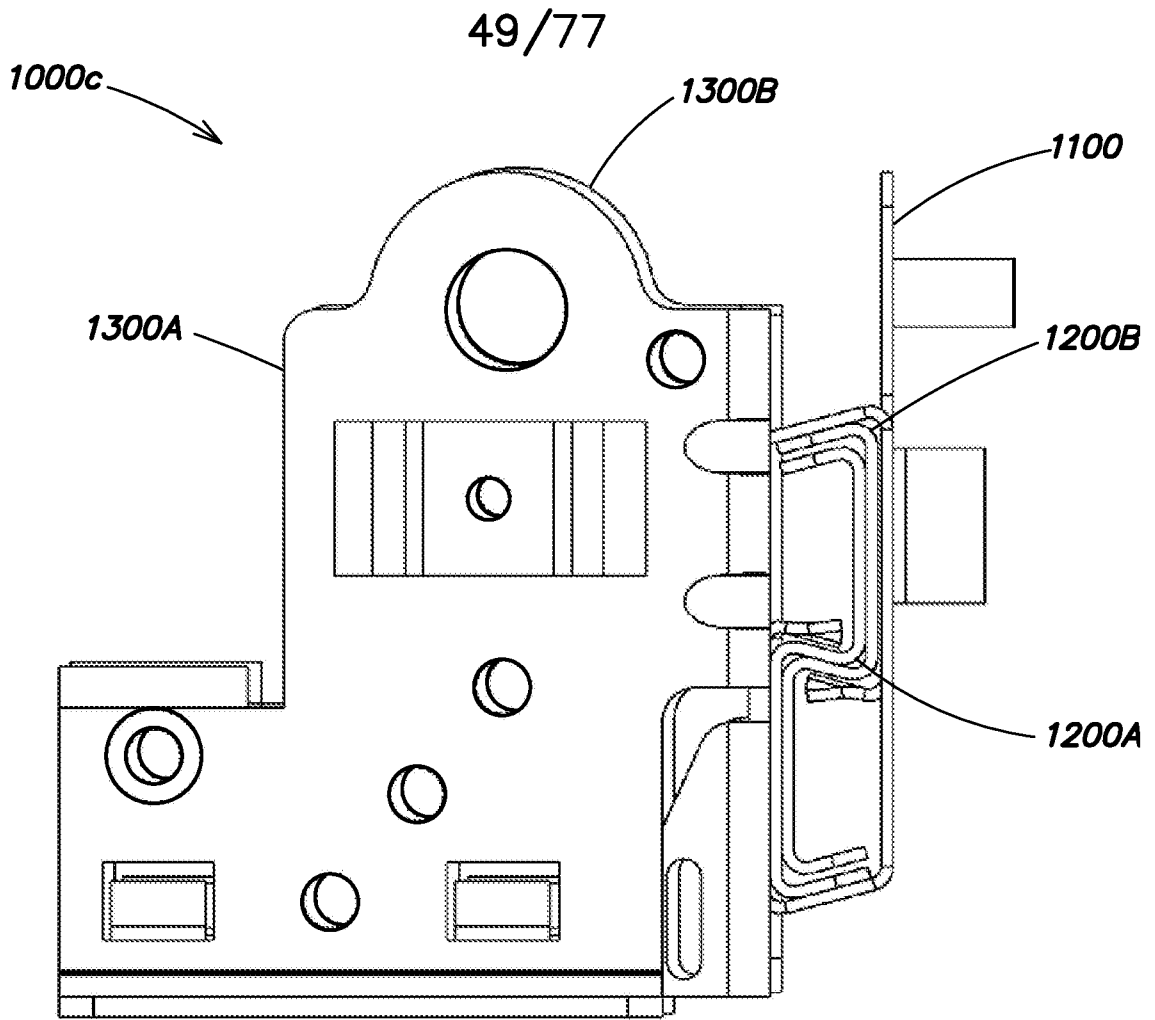


FIG. 11C



**FIG. 11D**



**FIG. 11E**

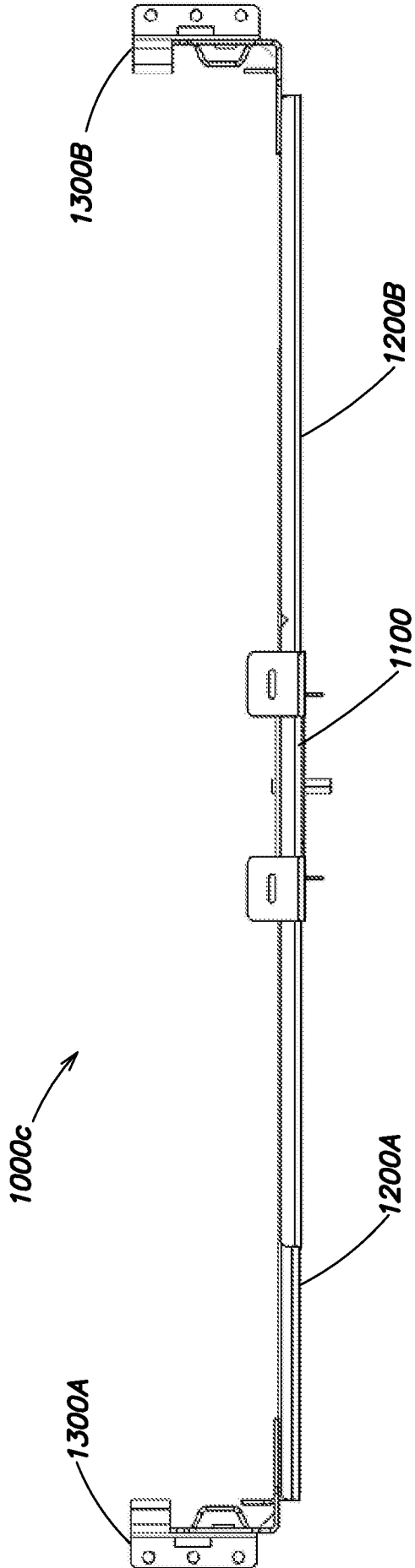
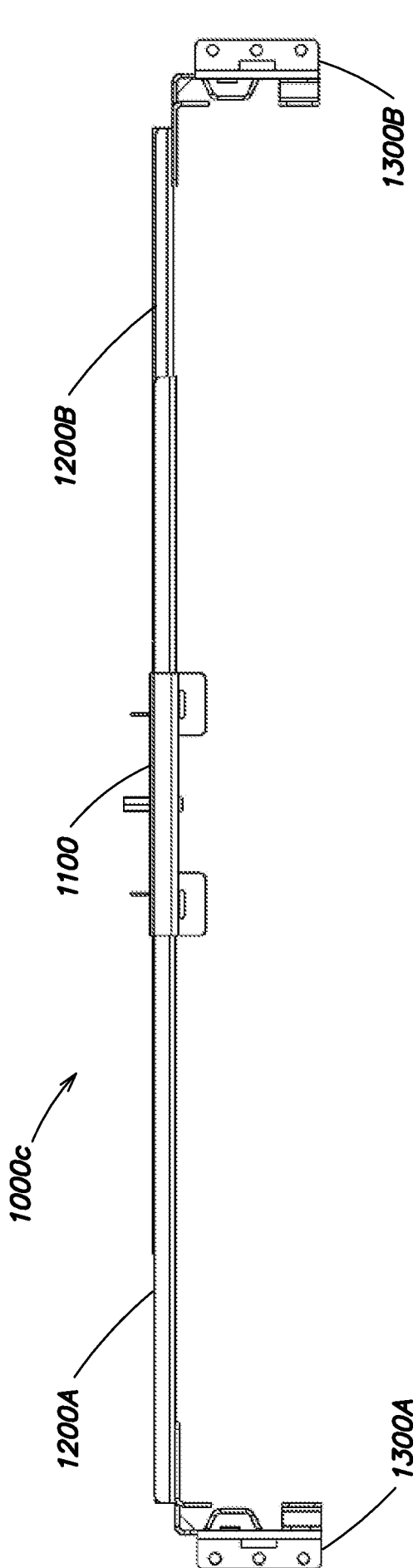


FIG. 11F

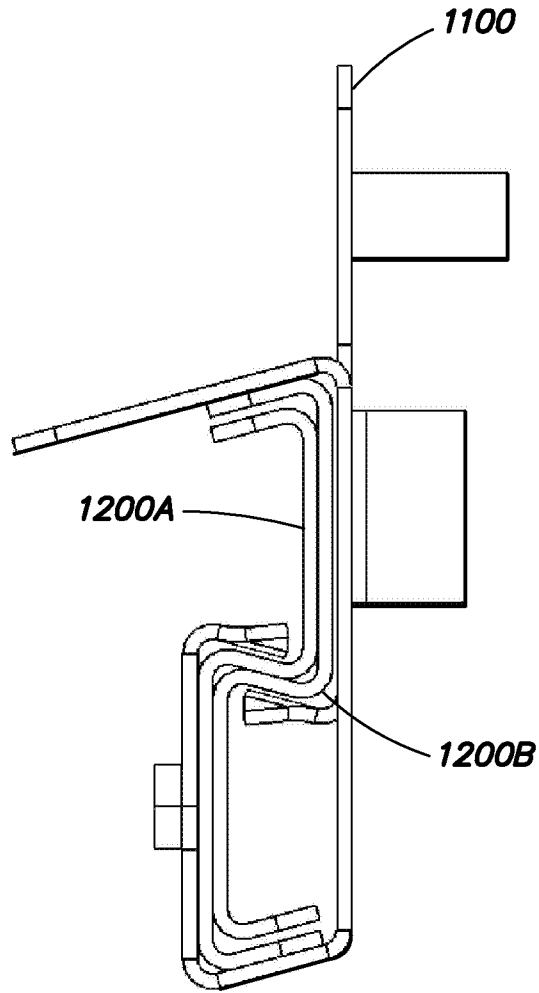


51/77

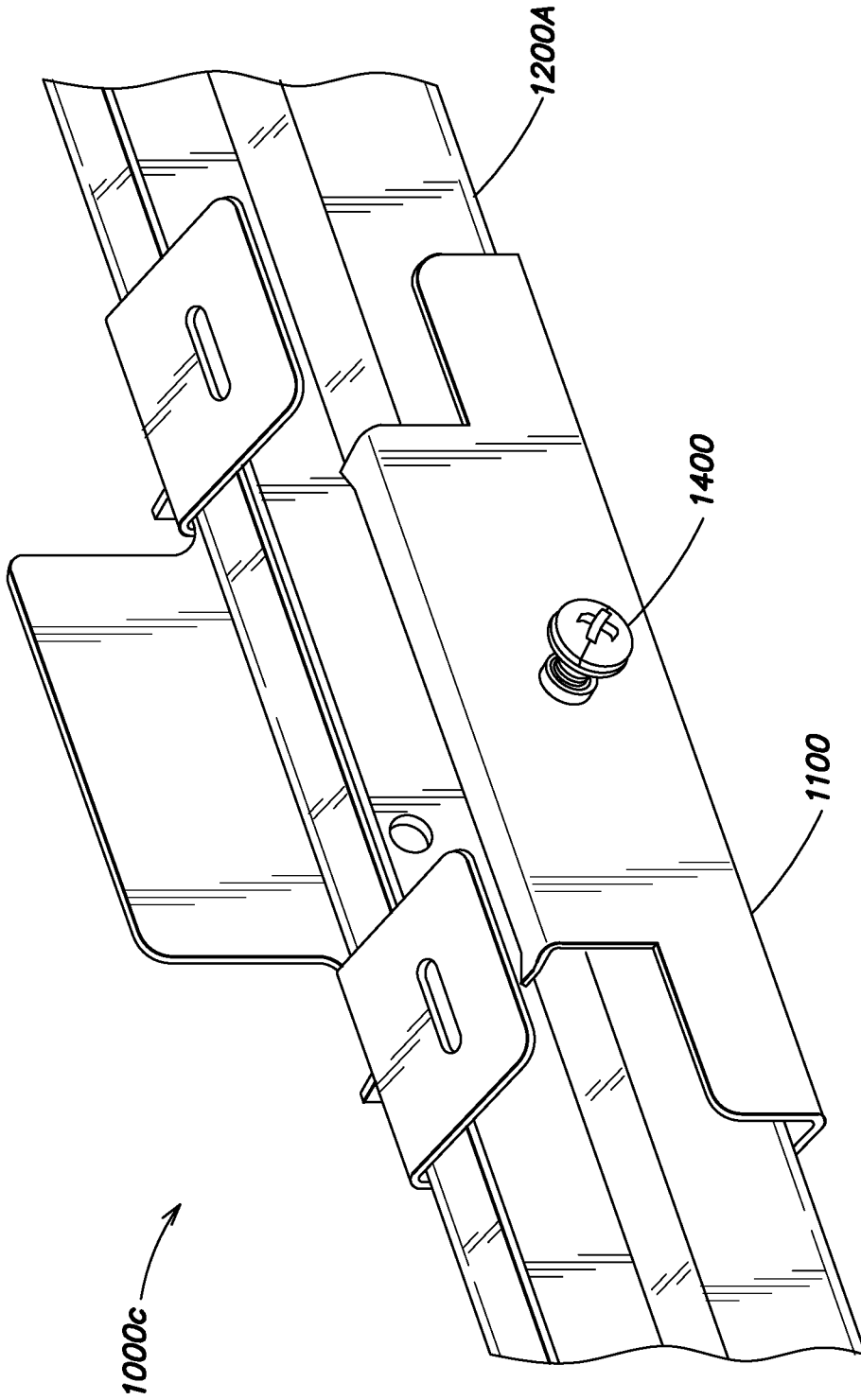
FIG. 11G

52/77

1000c →

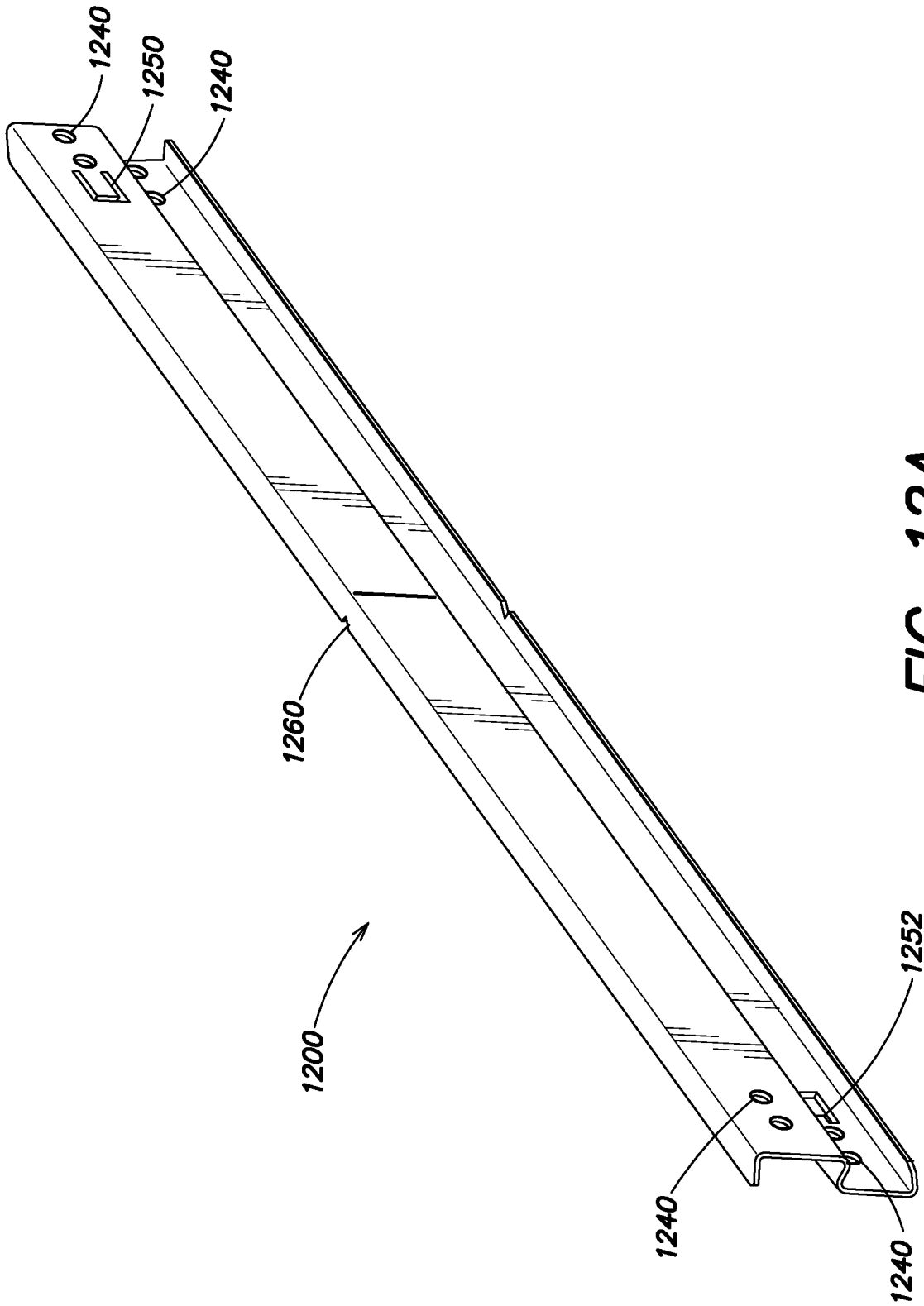


**FIG. 11H**

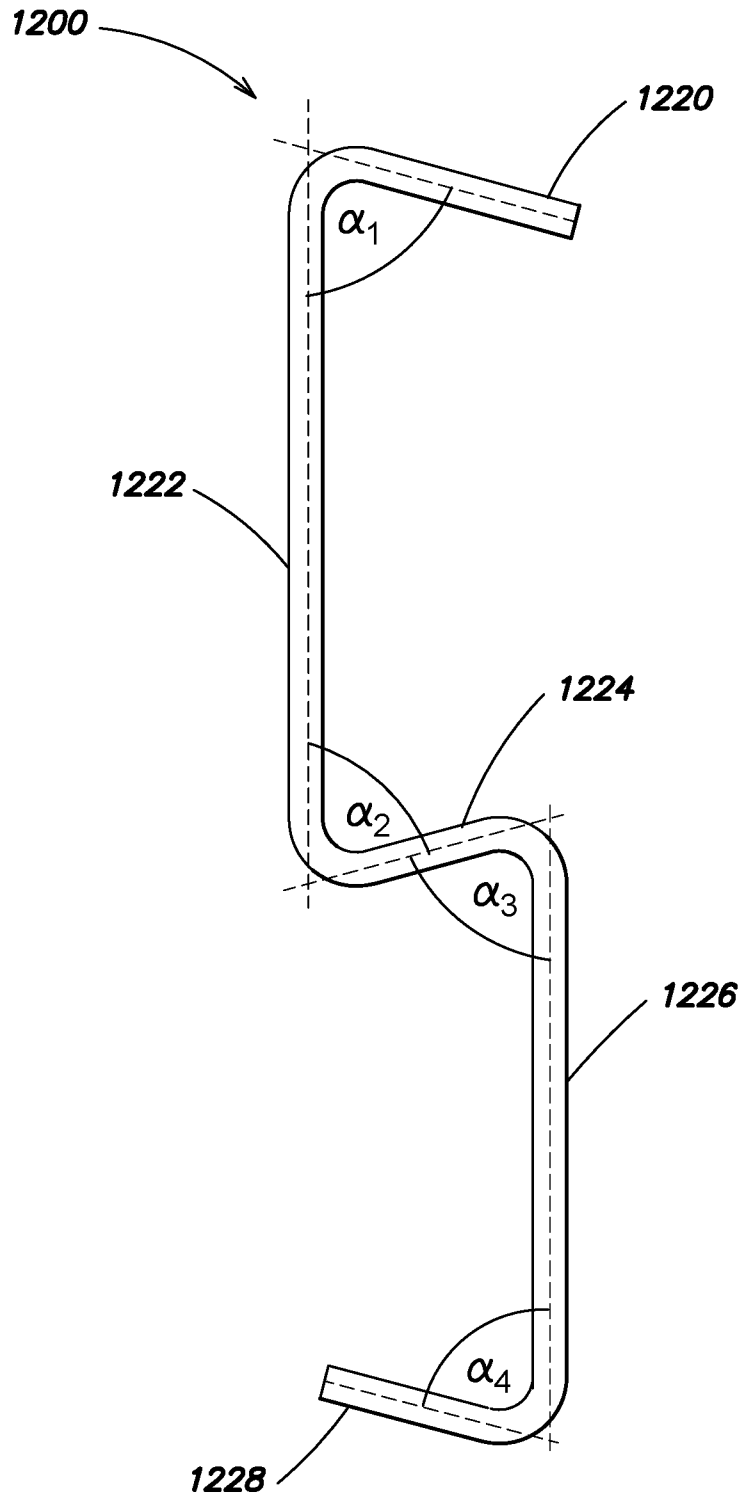


**FIG. 111**





55/77



**FIG. 12B**

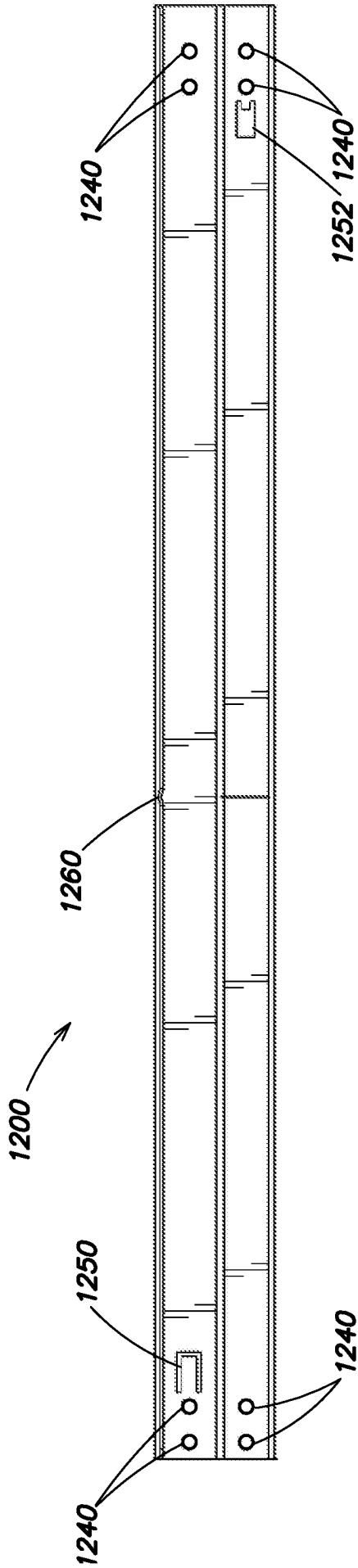


FIG. 12C

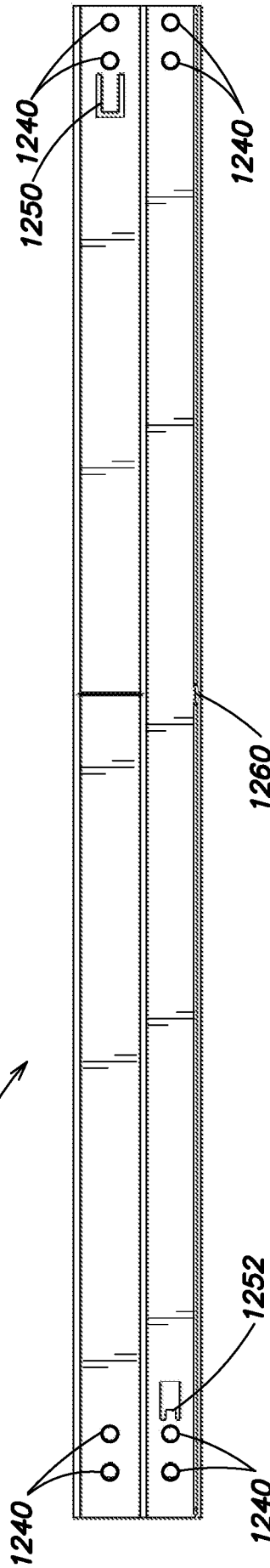
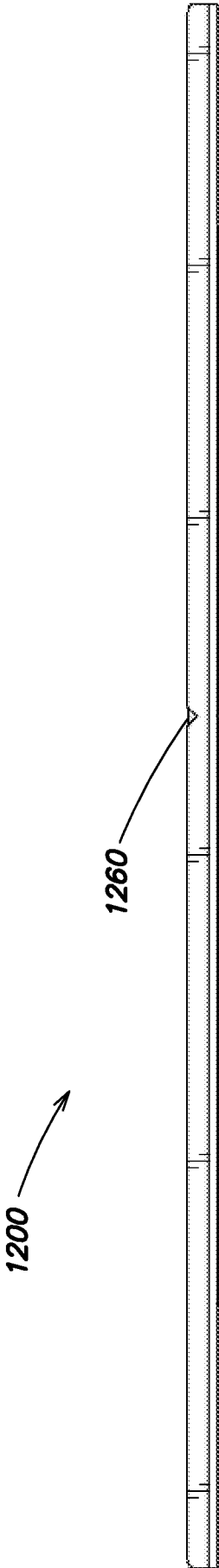
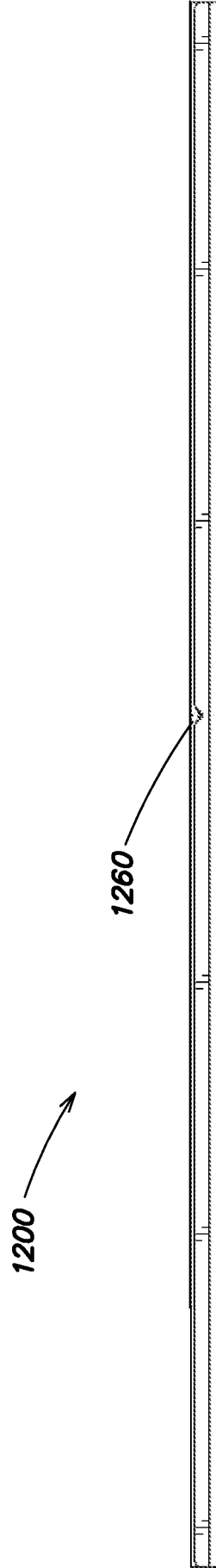


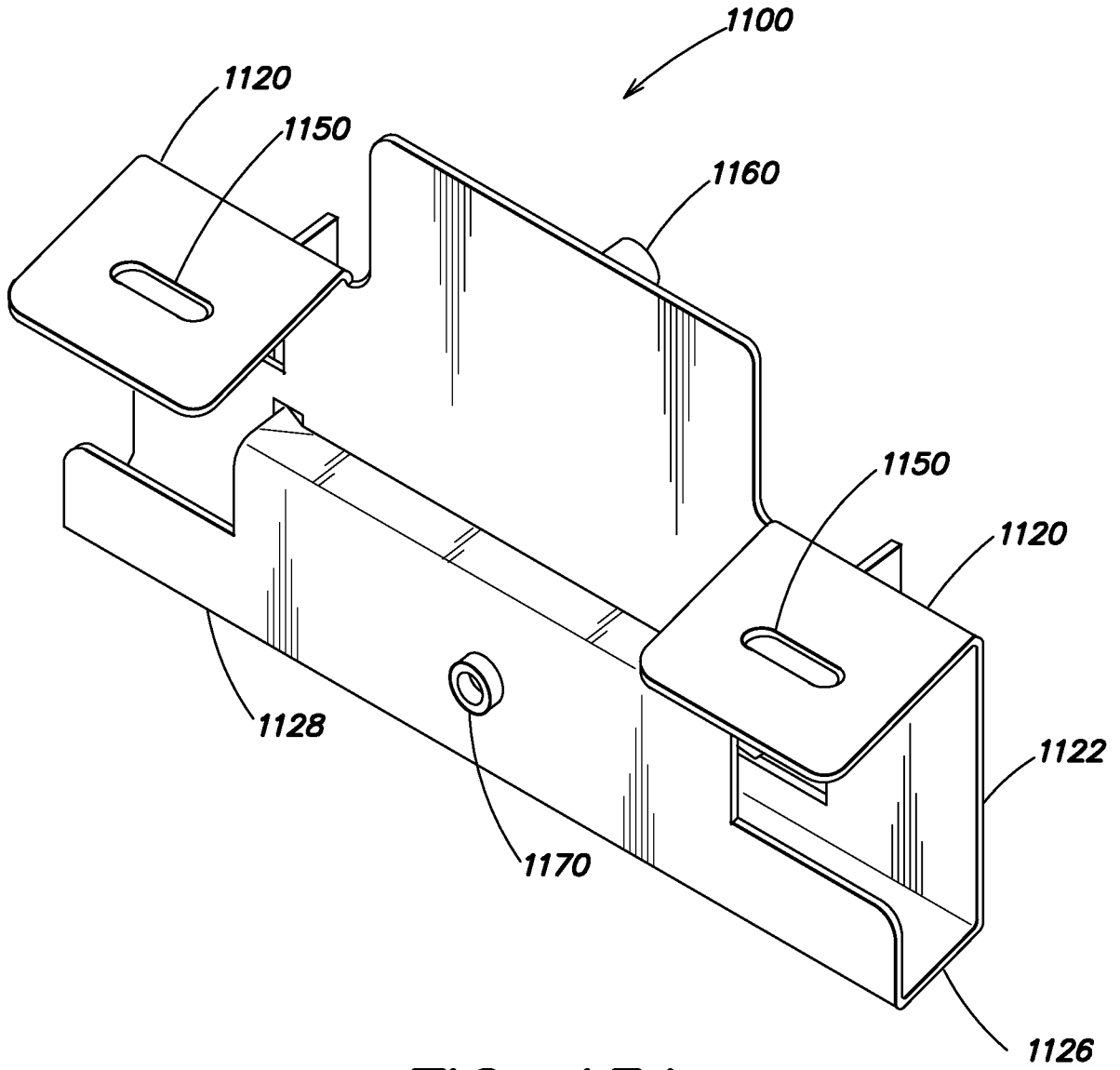
FIG. 12D



**FIG. 12E**

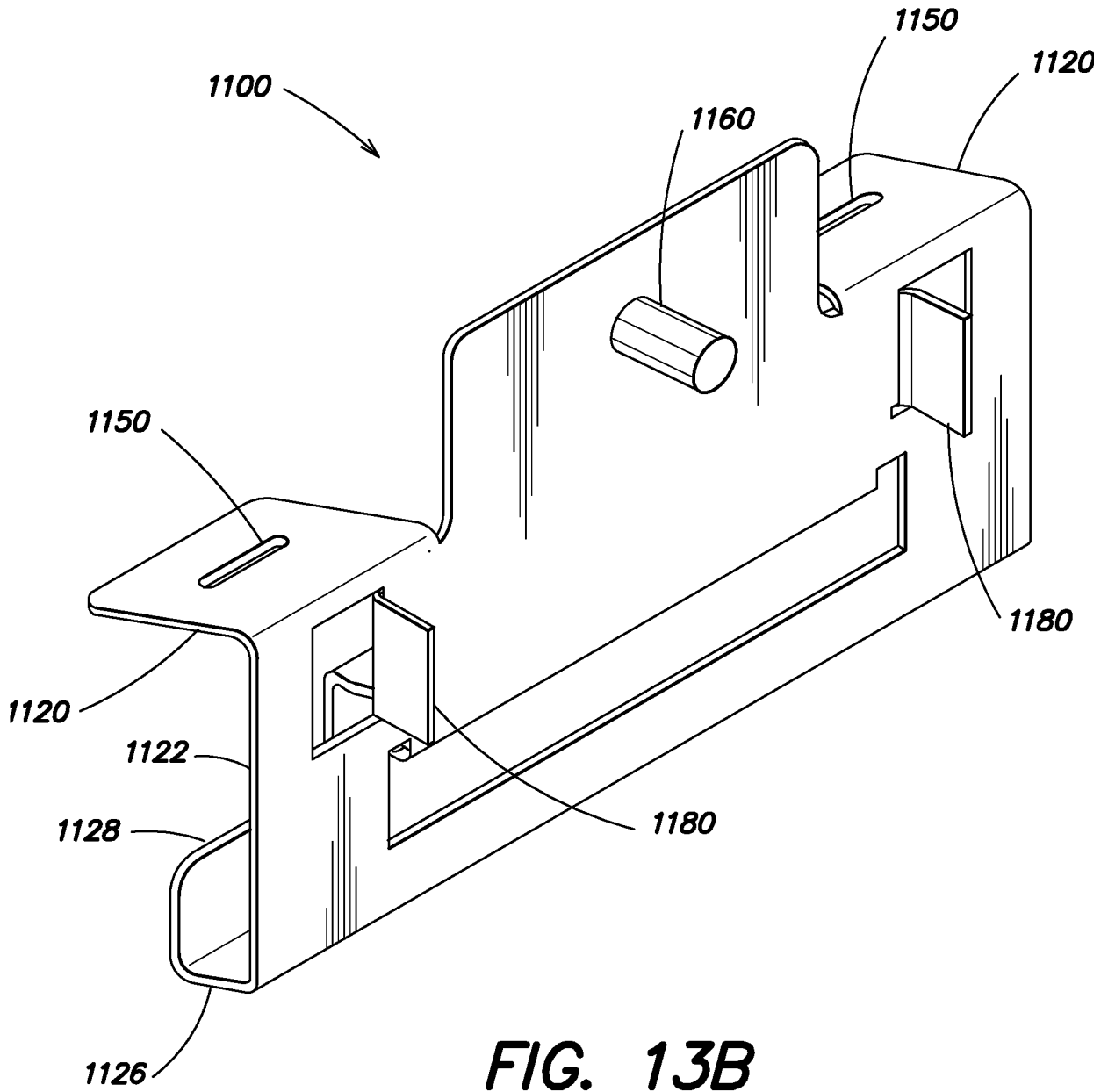


**FIG. 12F**

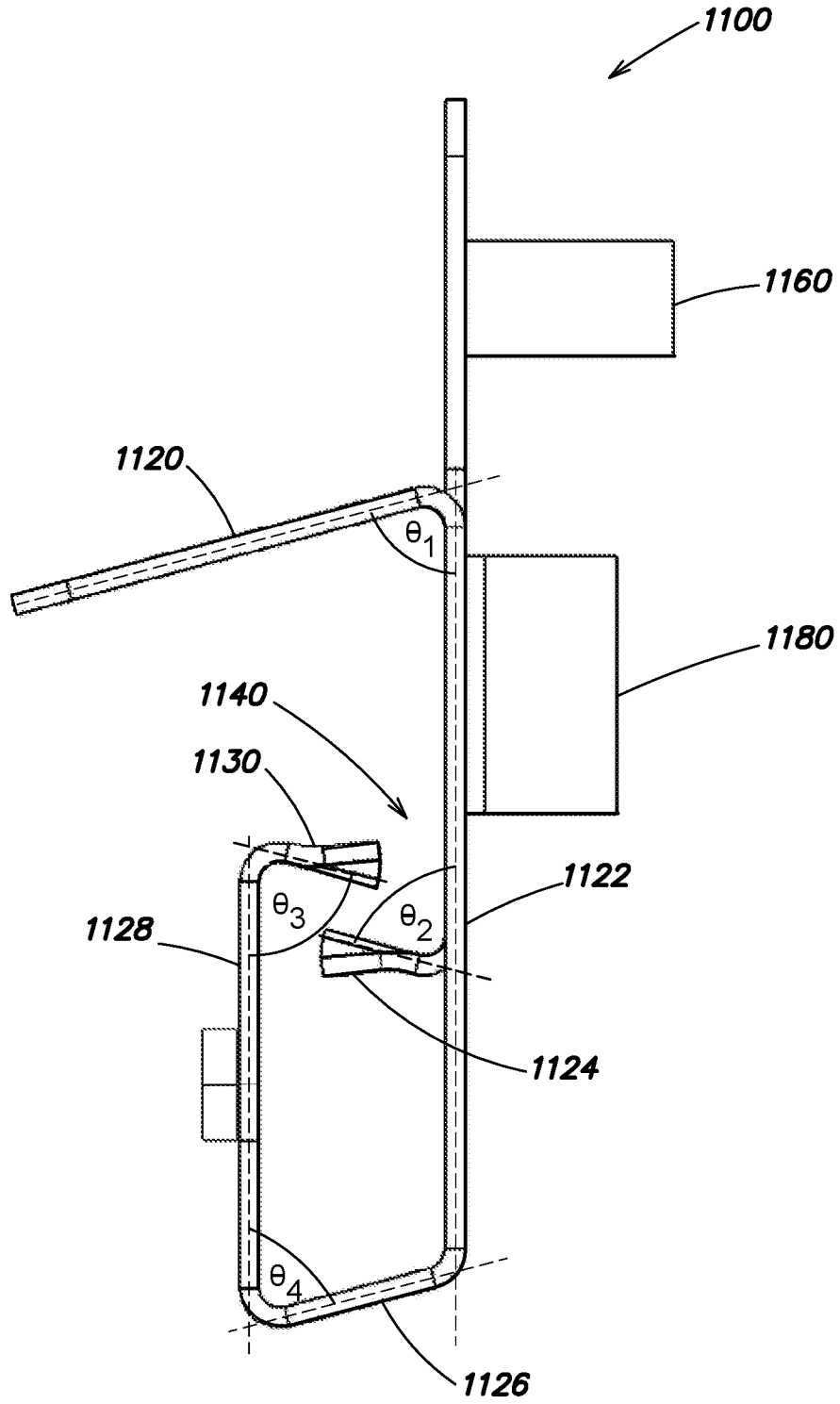


**FIG. 13A**

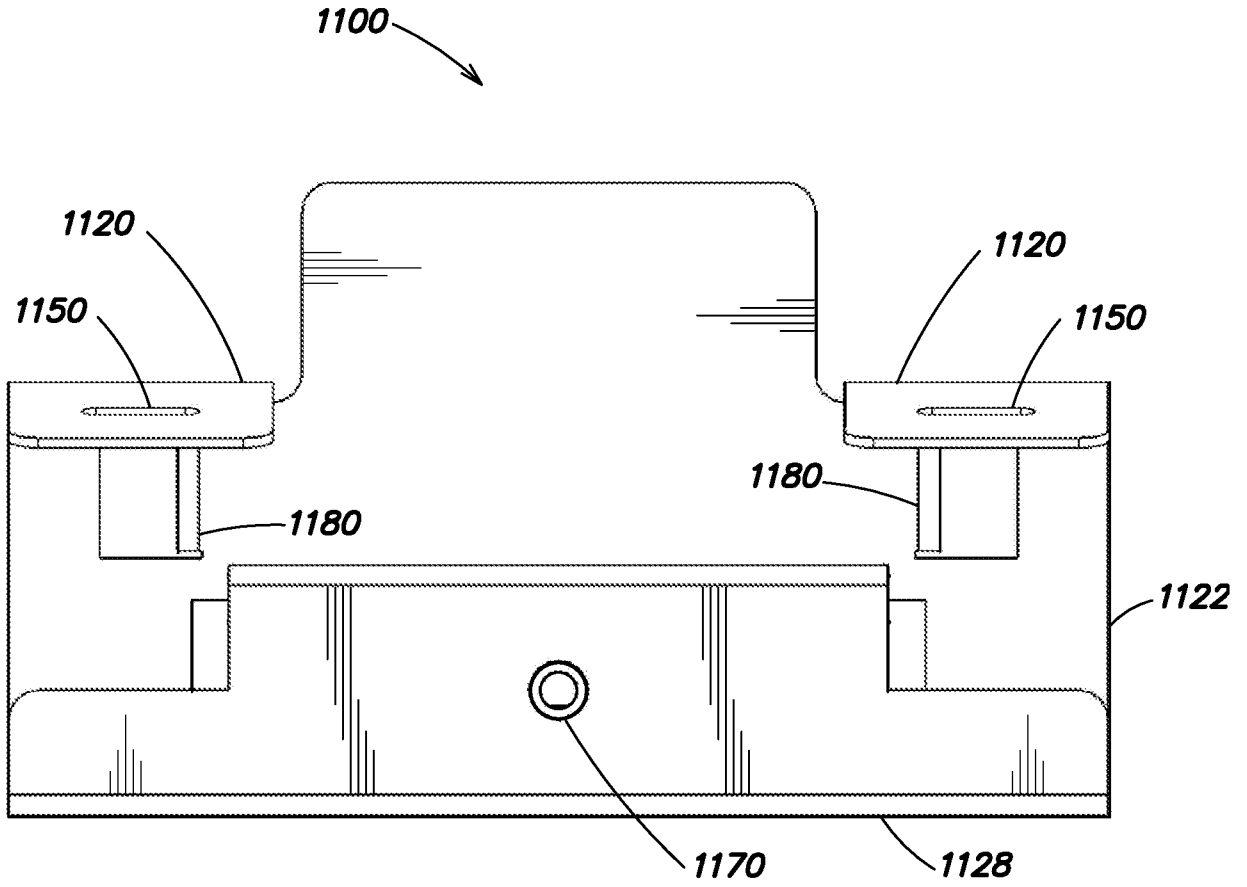
59/77



60/77

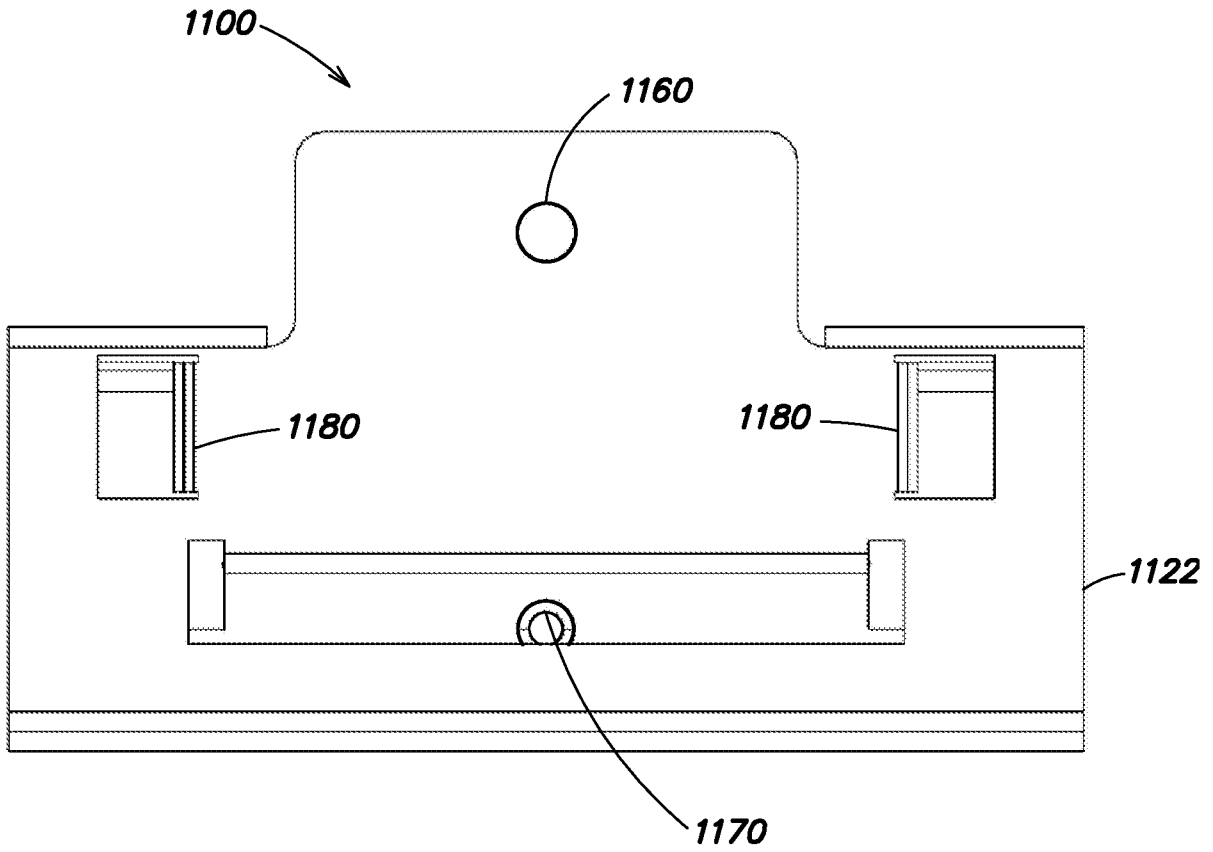


**FIG. 13C**

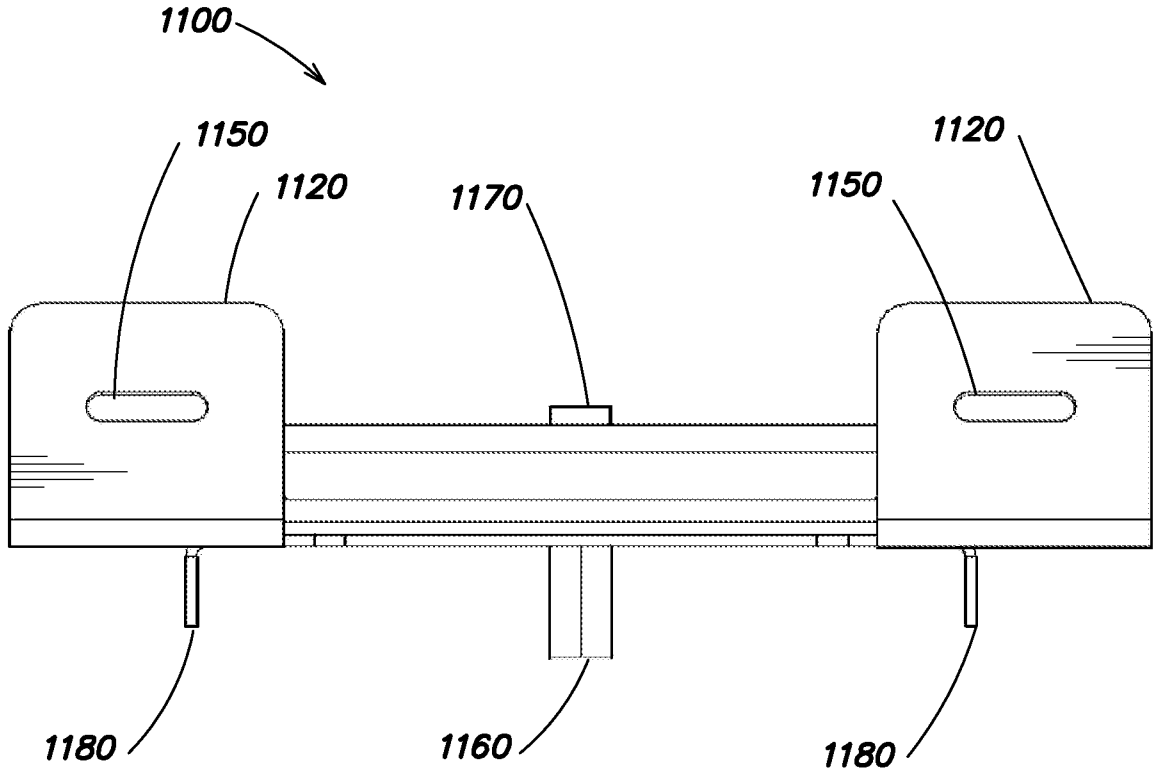


**FIG. 13D**

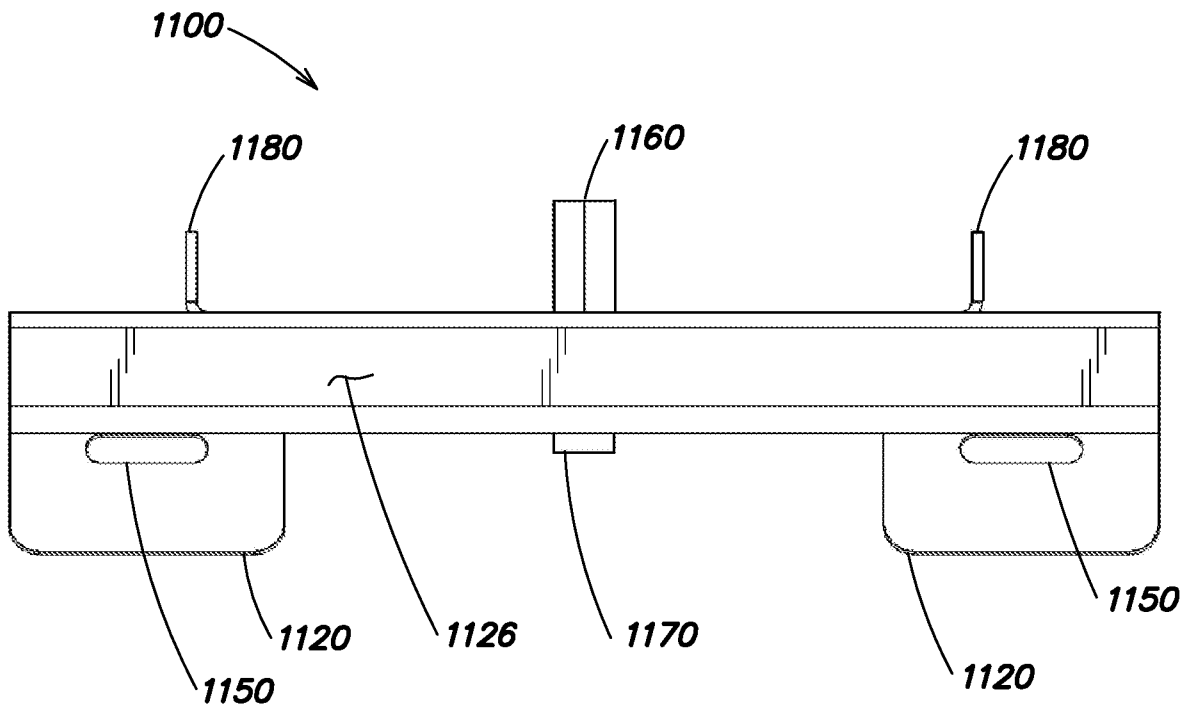




**FIG. 13E**

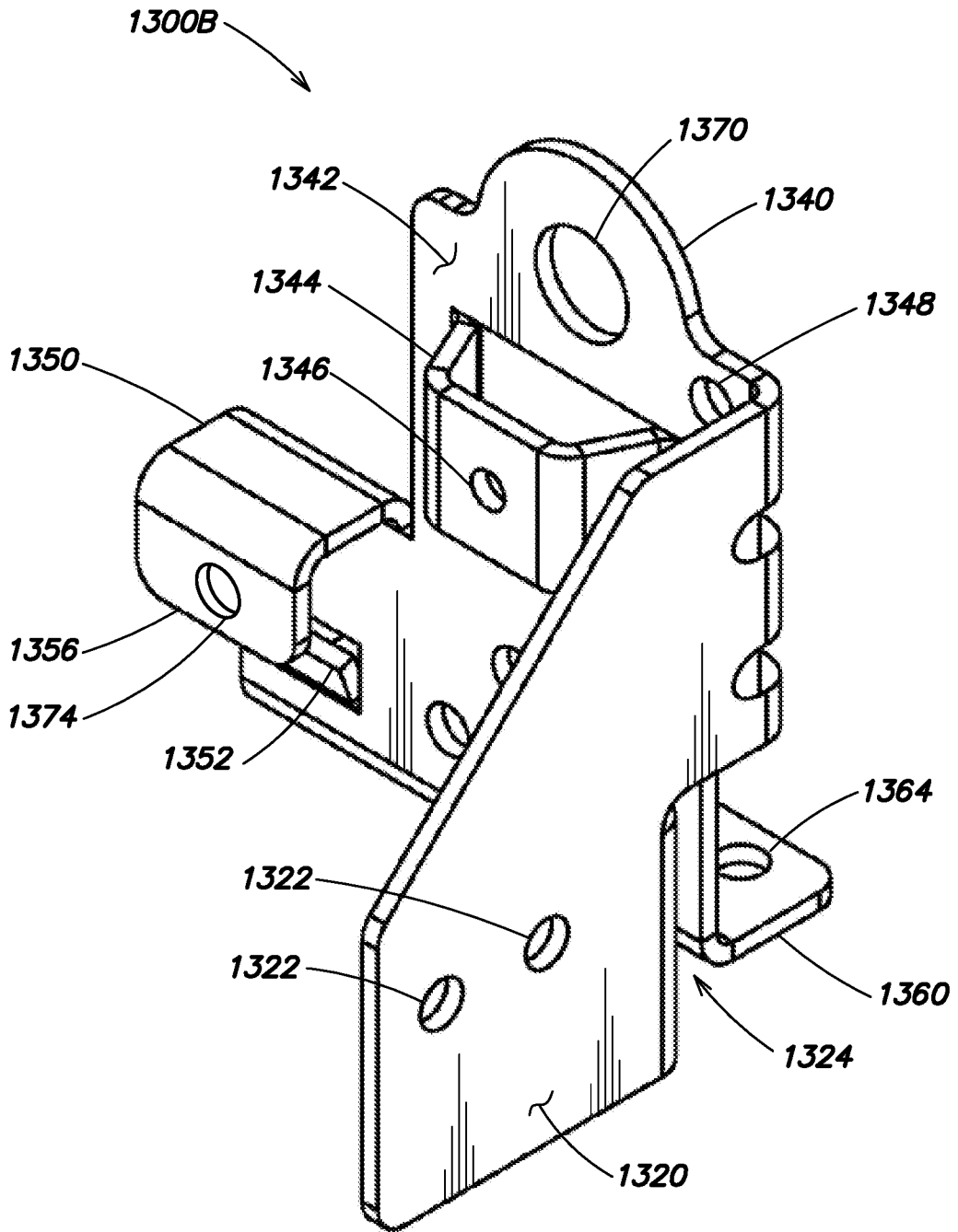


**FIG. 13F**



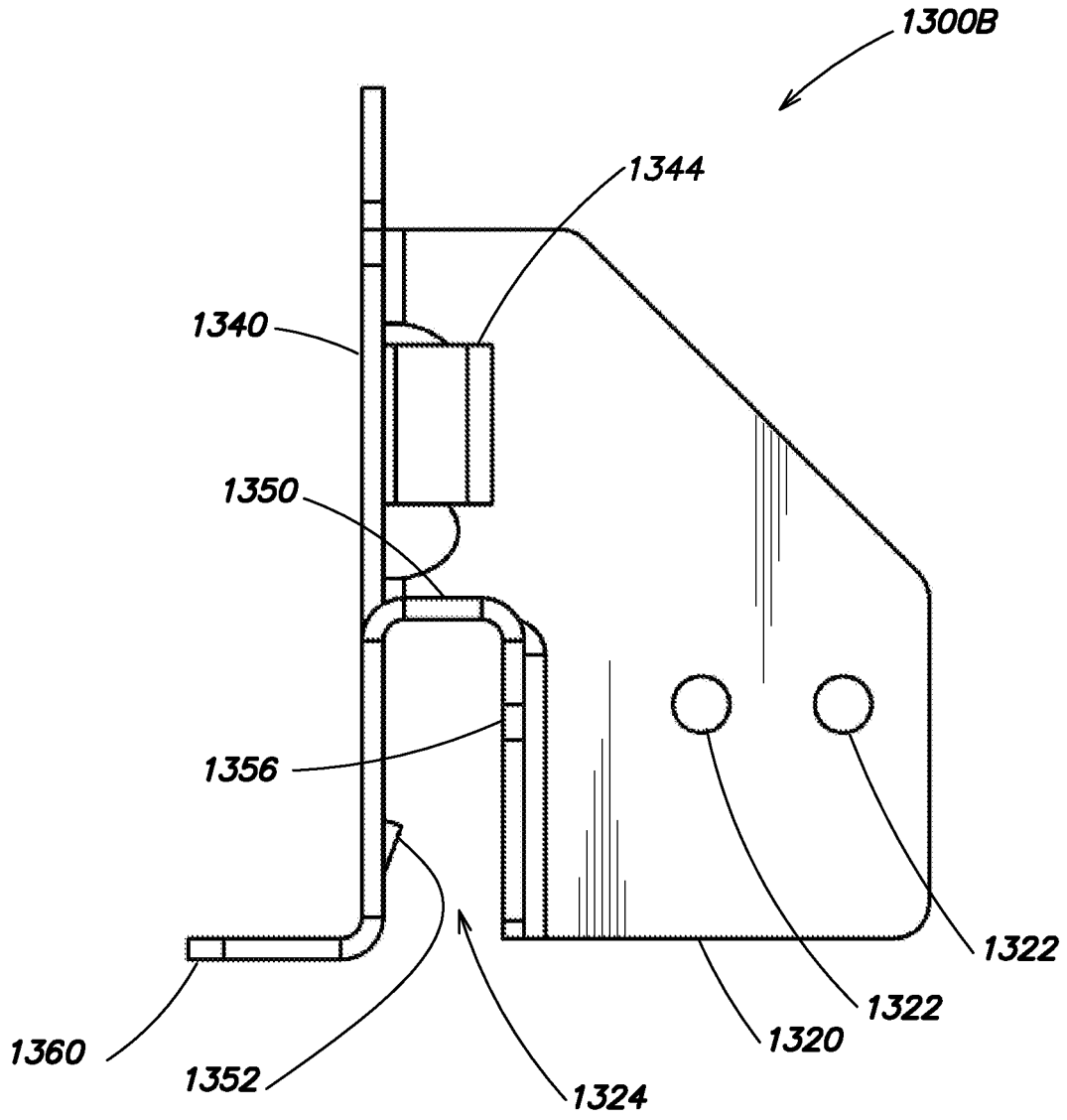
**FIG. 13G**

64/77

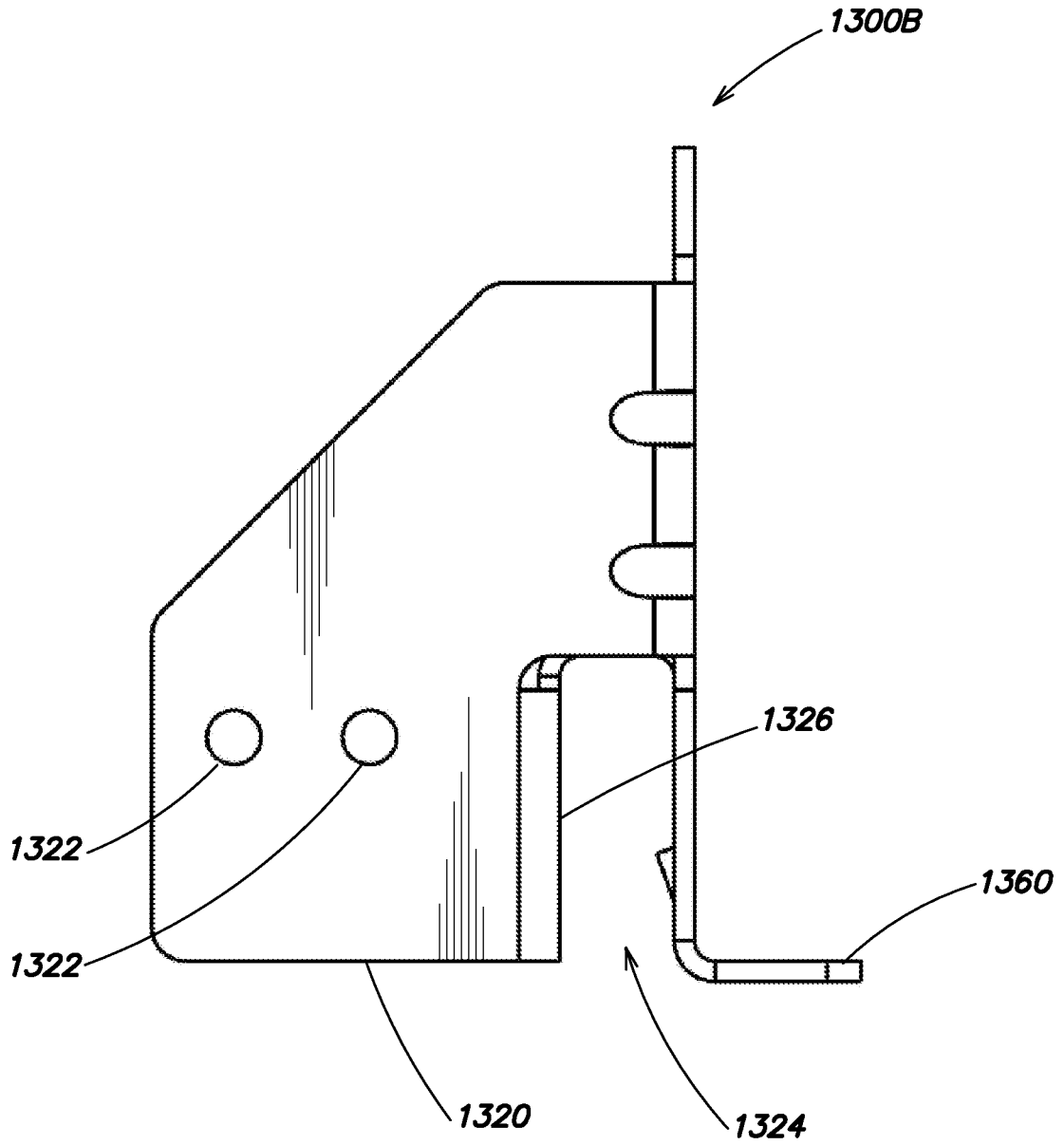


**FIG. 14A**

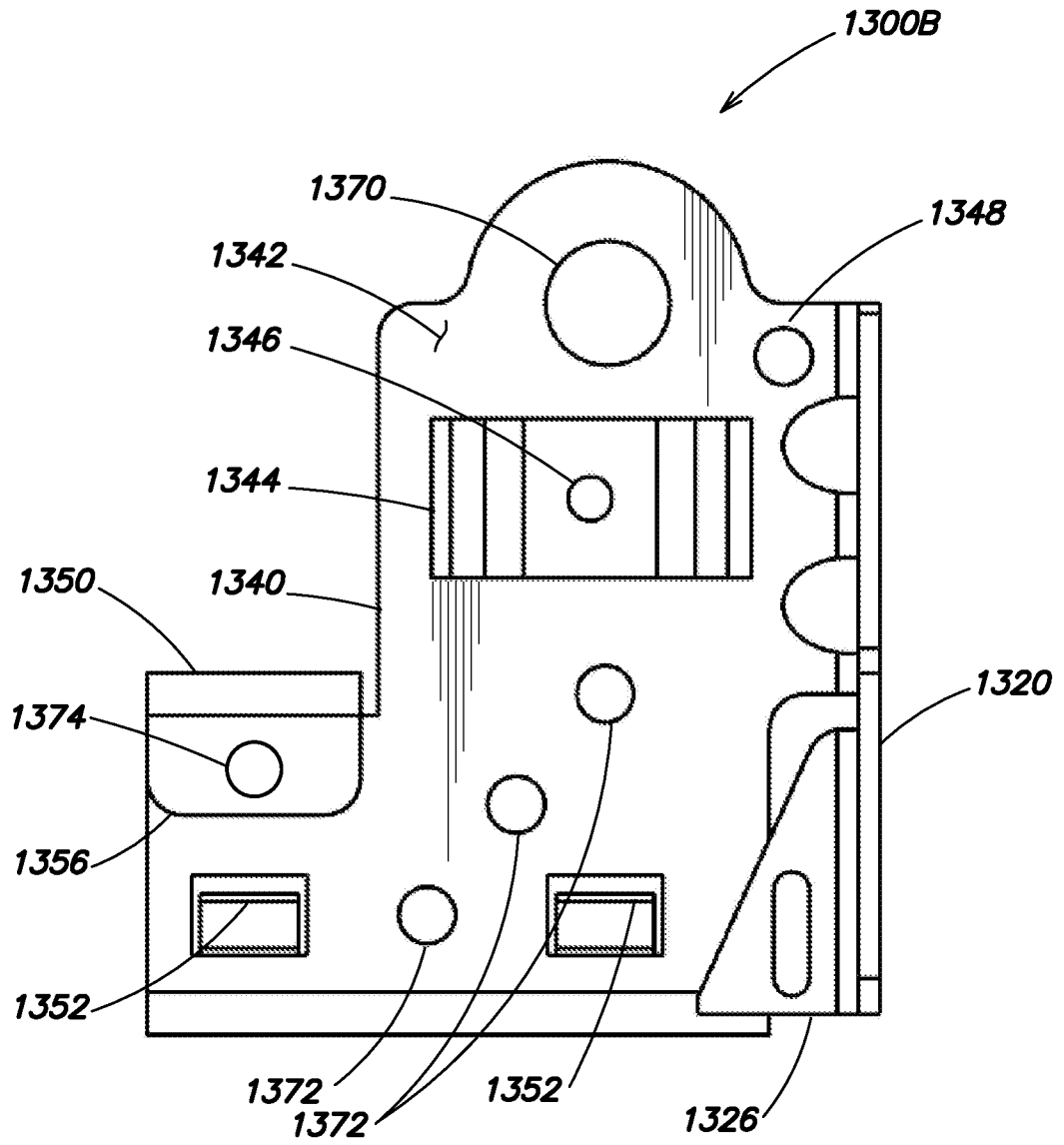
65/77



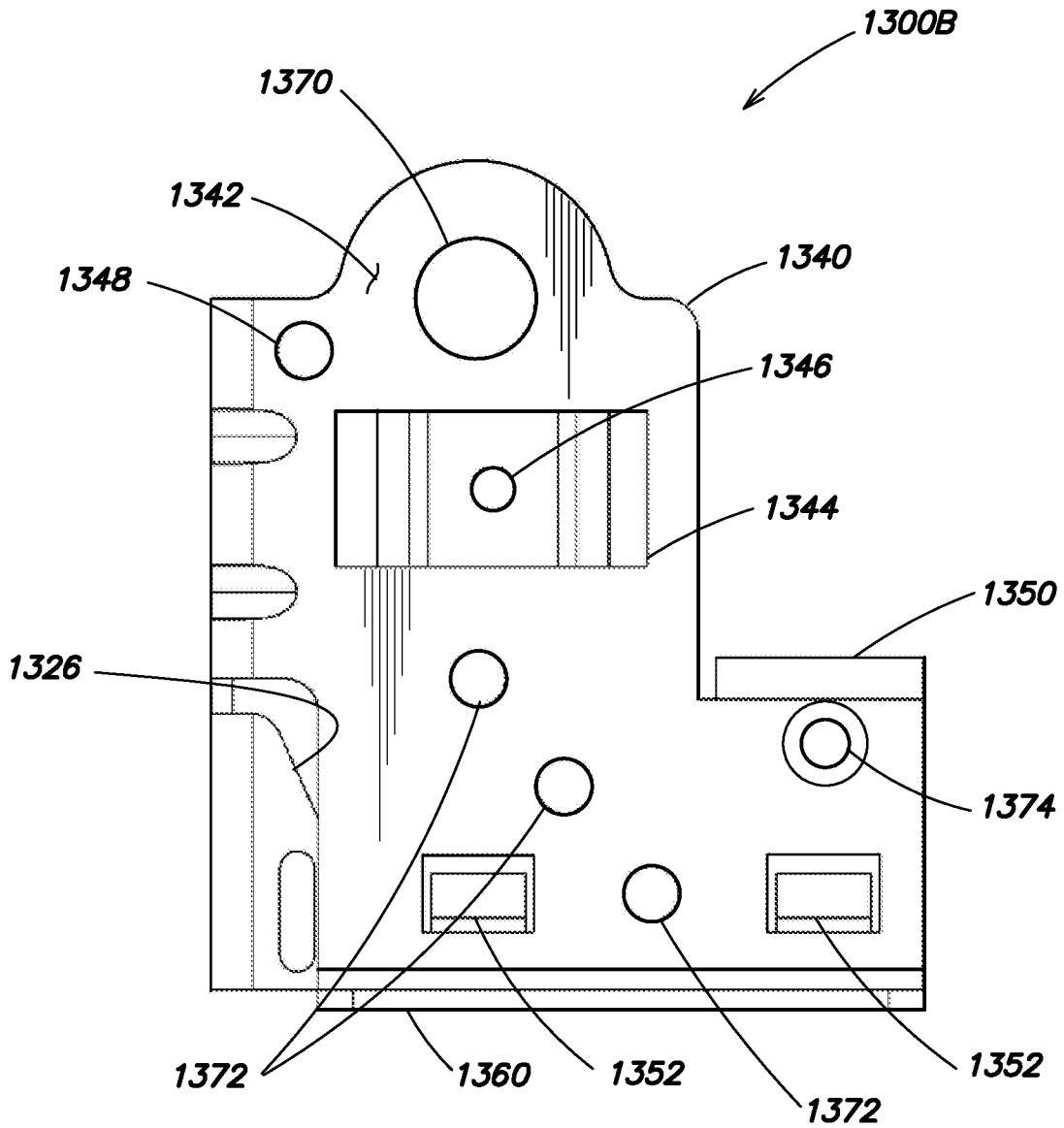
**FIG. 14B**



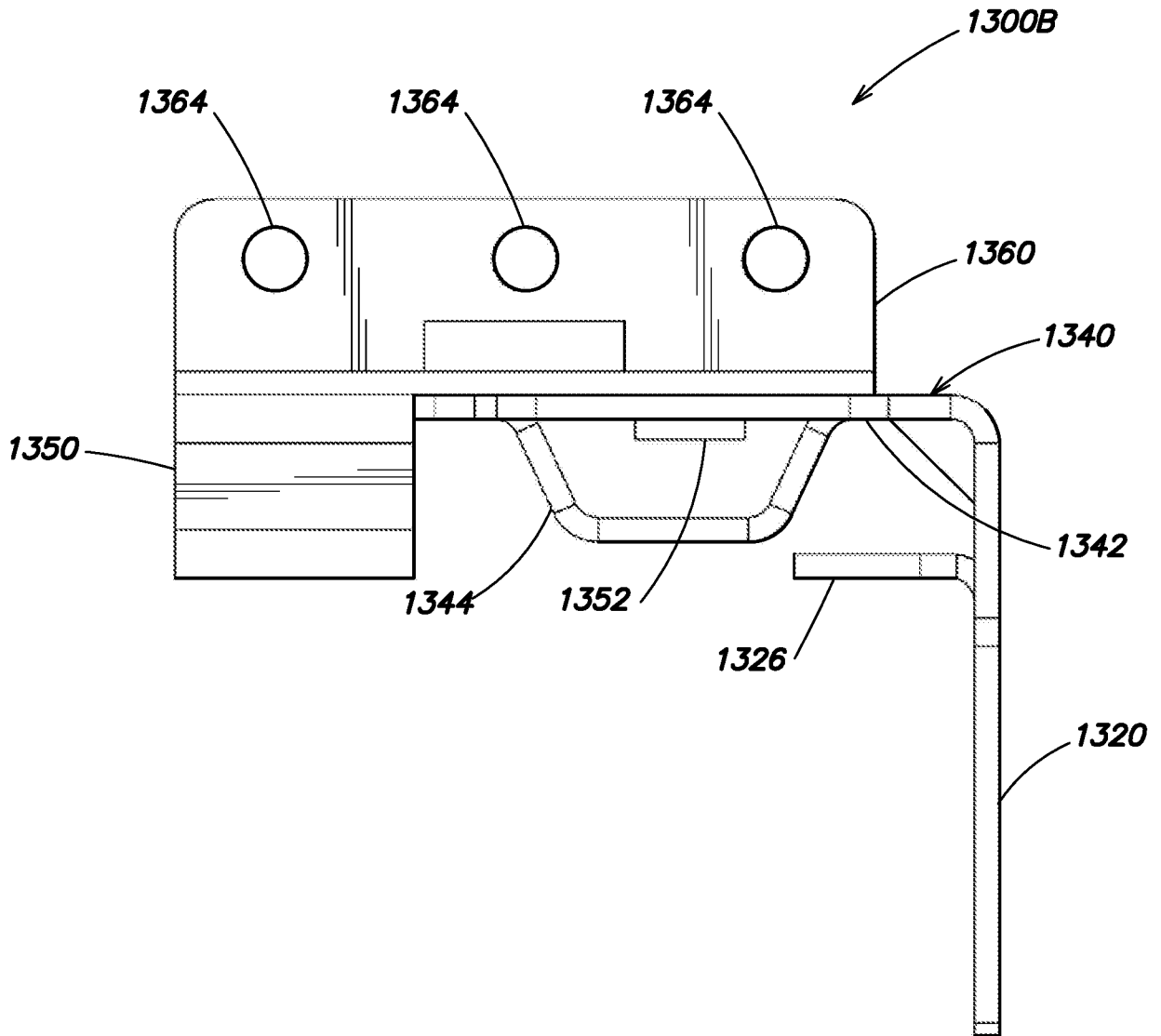
**FIG. 14C**



**FIG. 14D**

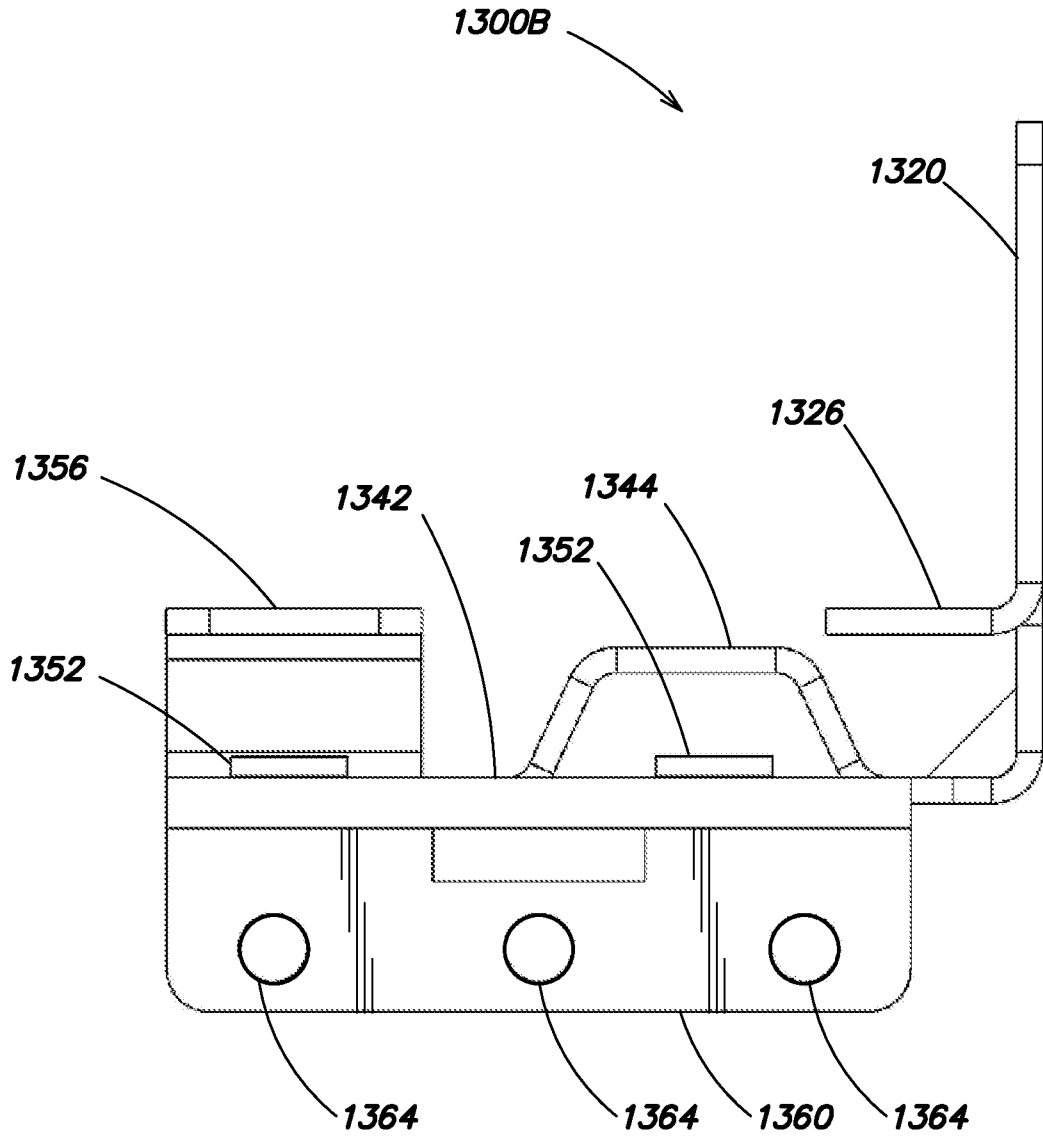


**FIG. 14E**

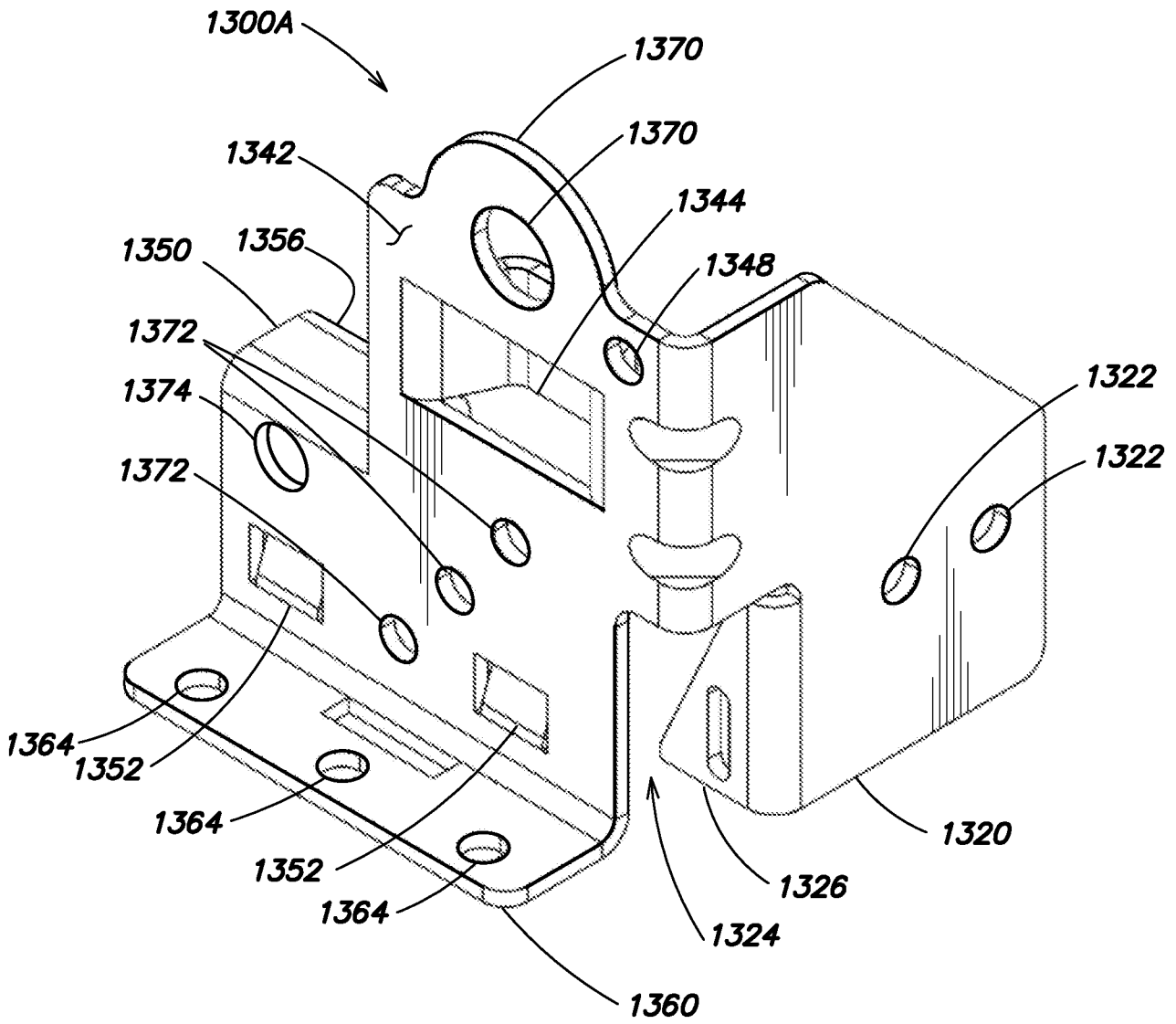


**FIG. 14F**

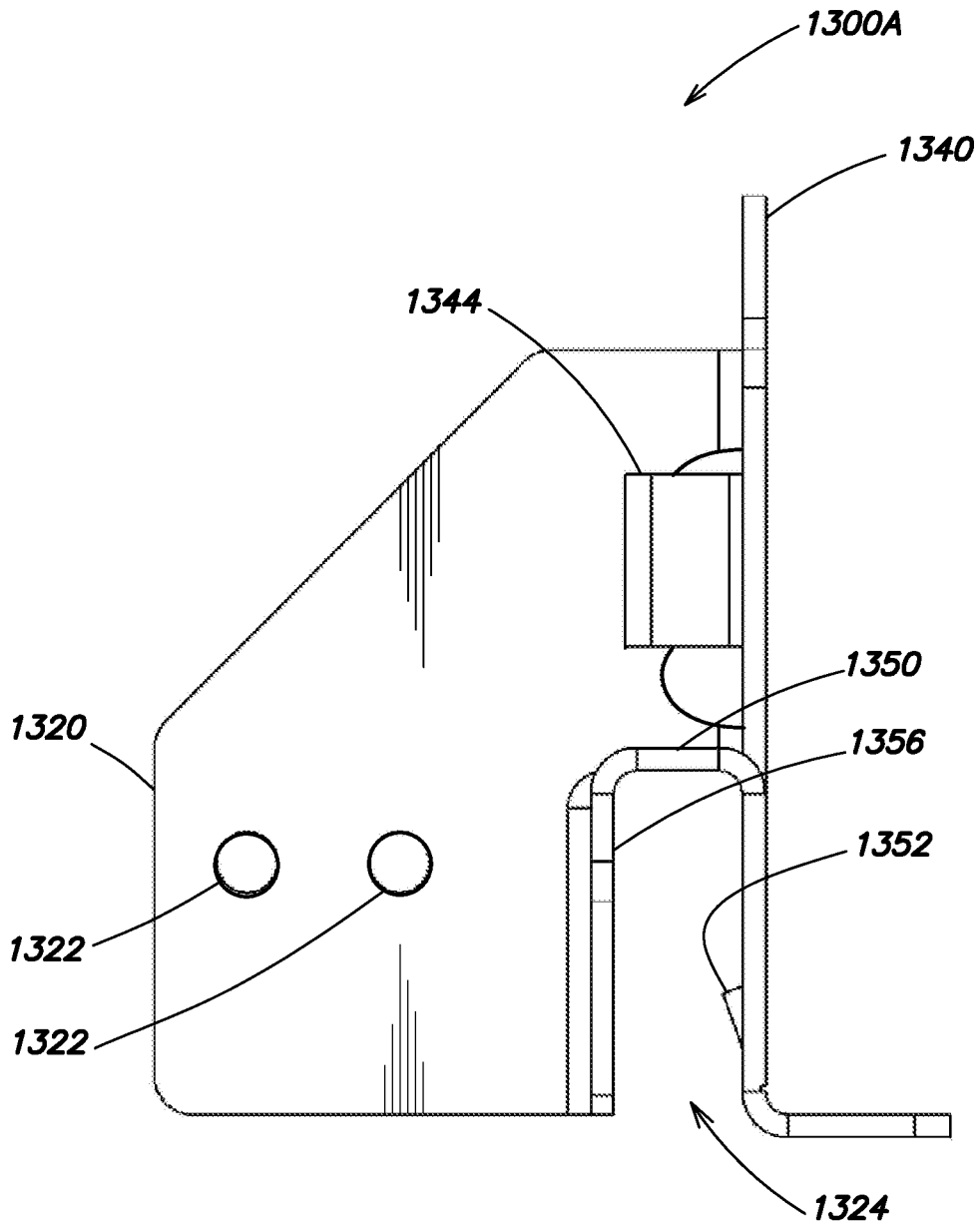




**FIG. 14G**

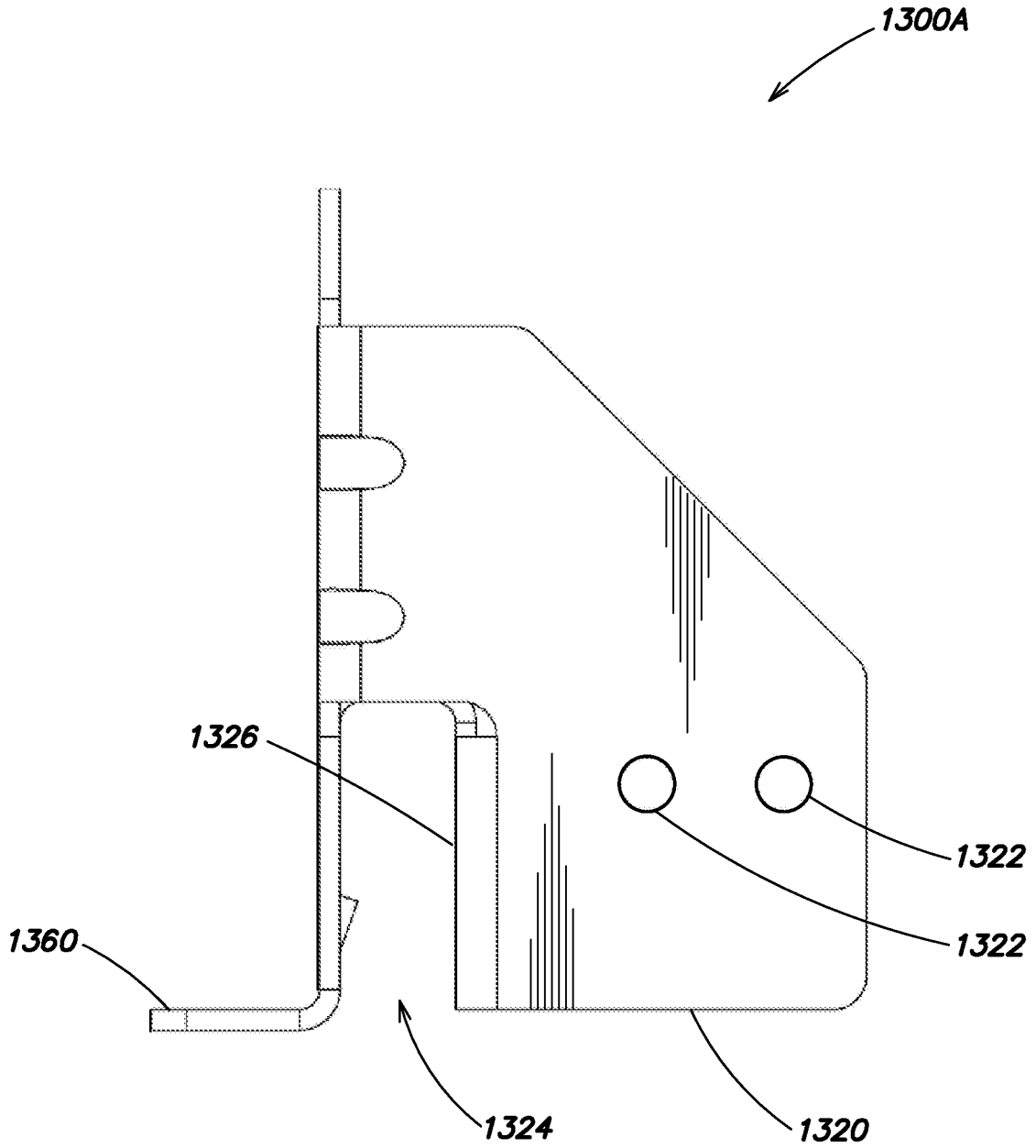


**FIG. 15A**



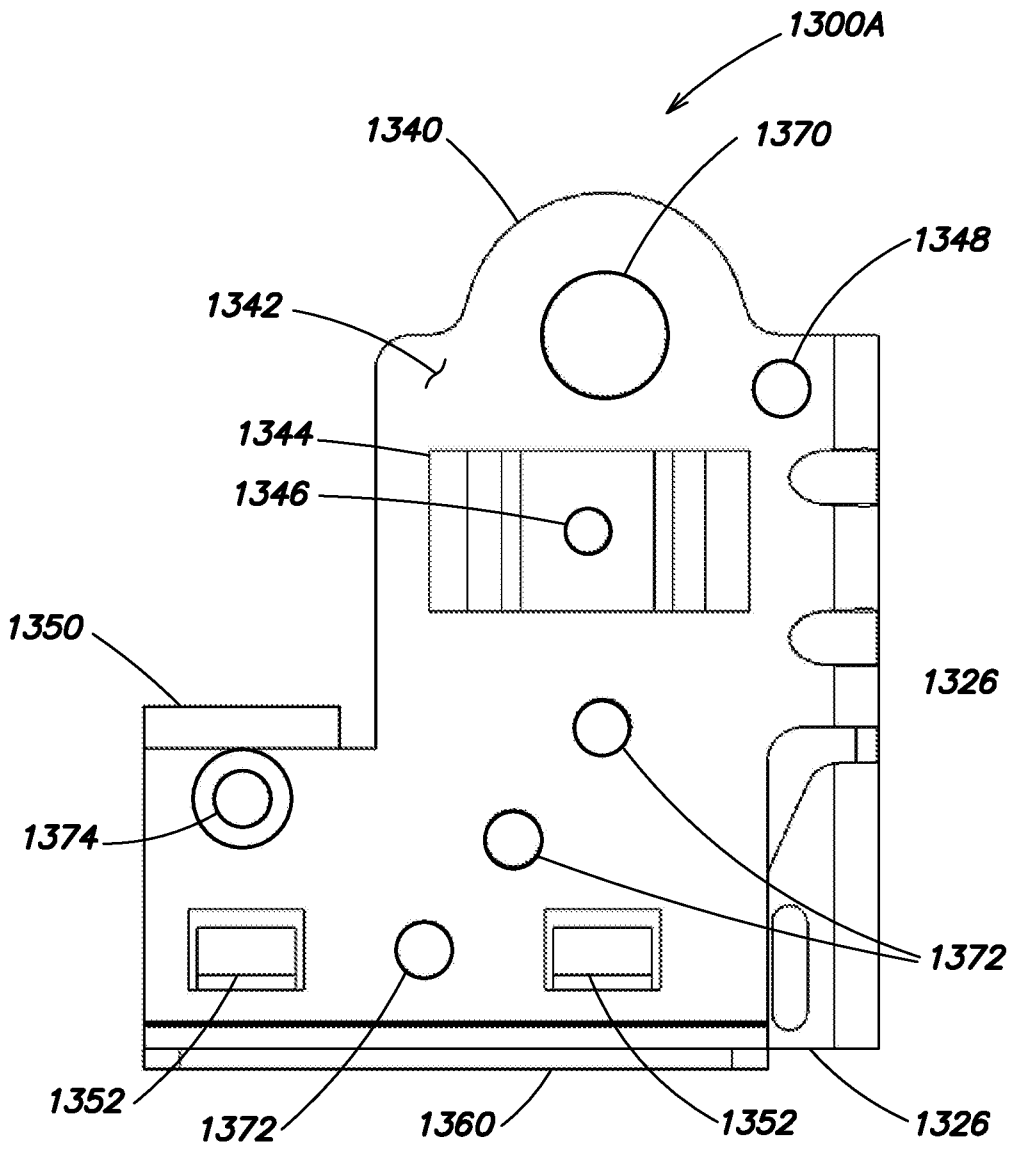
**FIG. 15B**

73/77



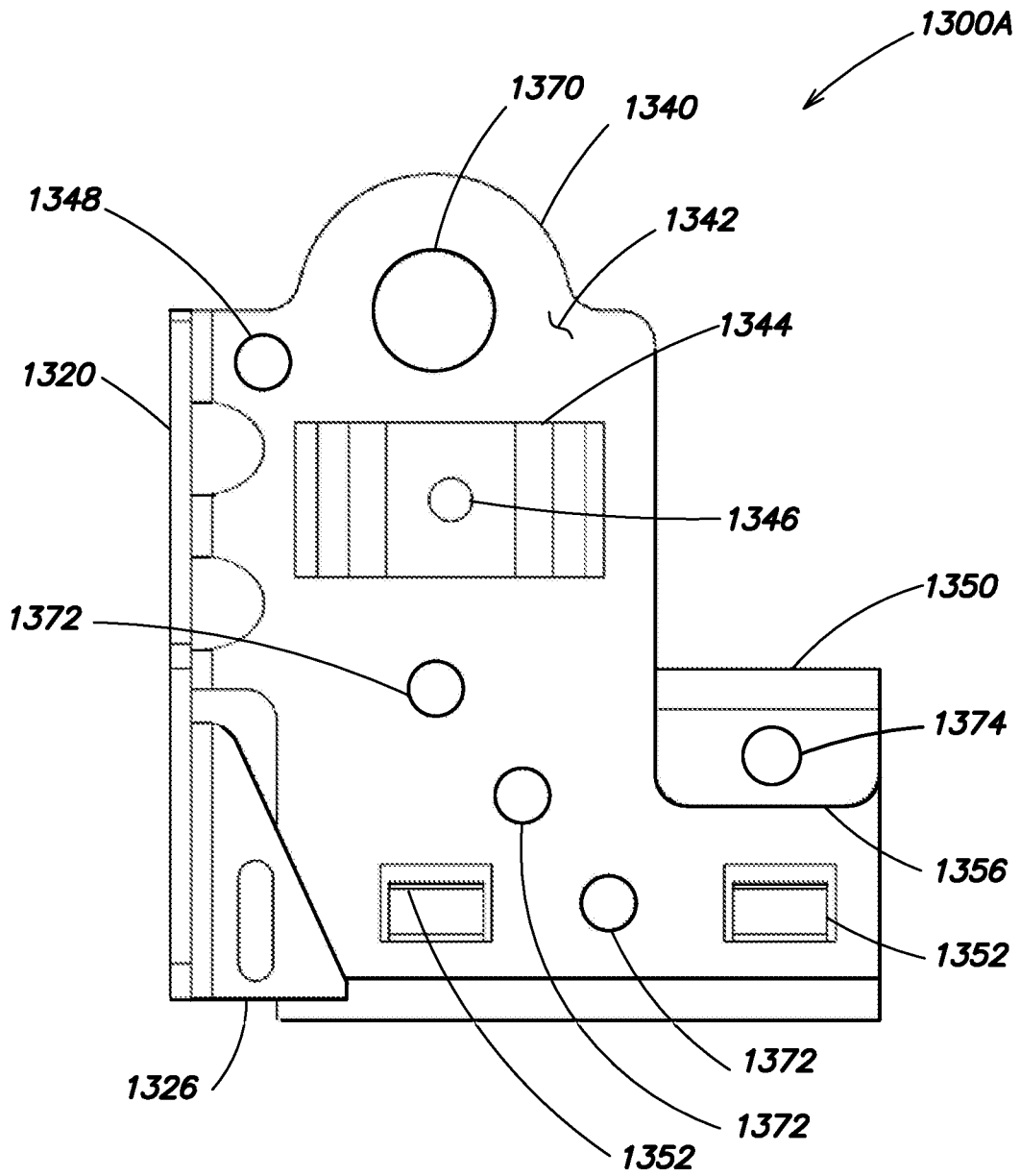
**FIG. 15C**

74/77



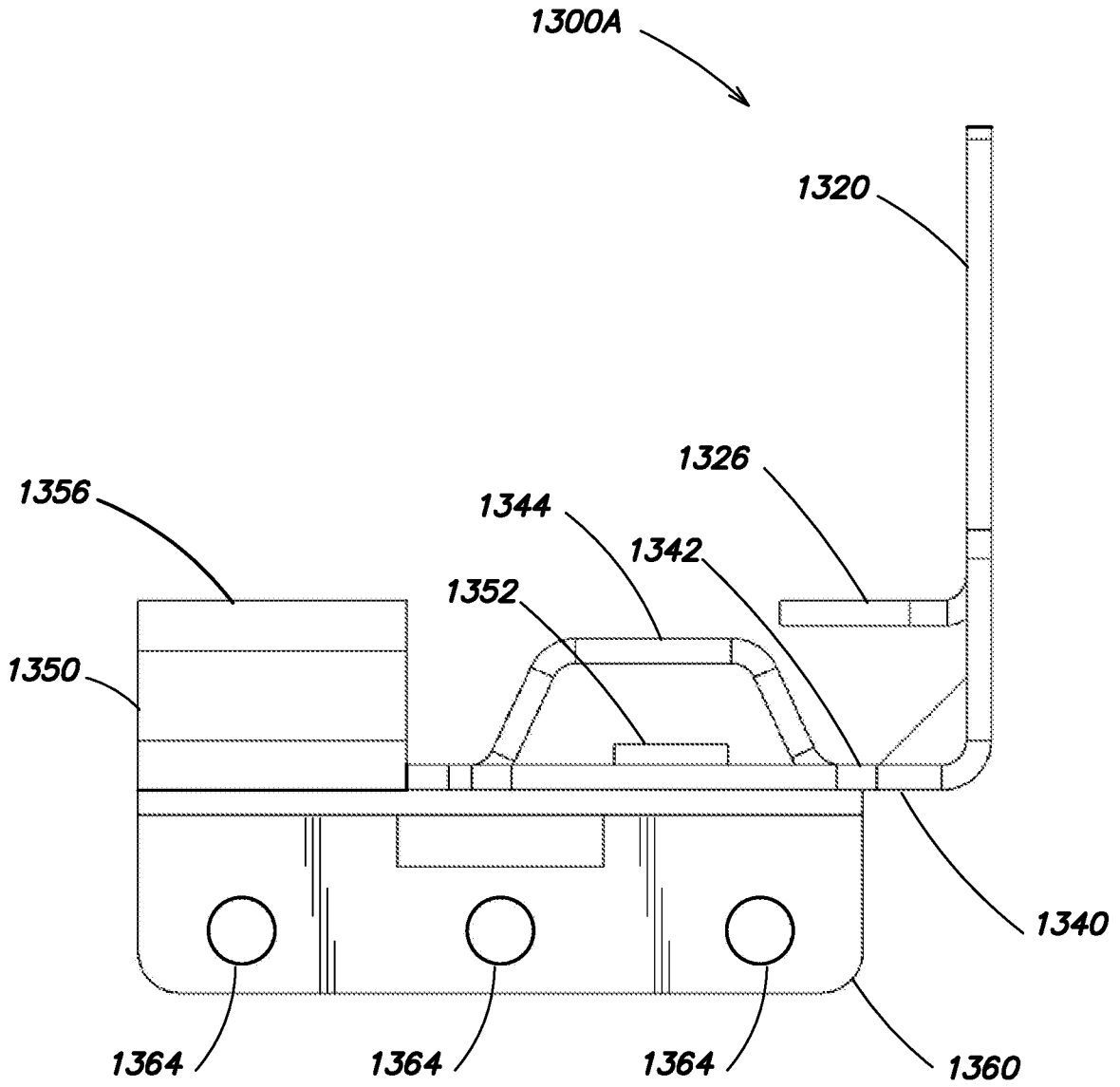
**FIG. 15D**

75/77

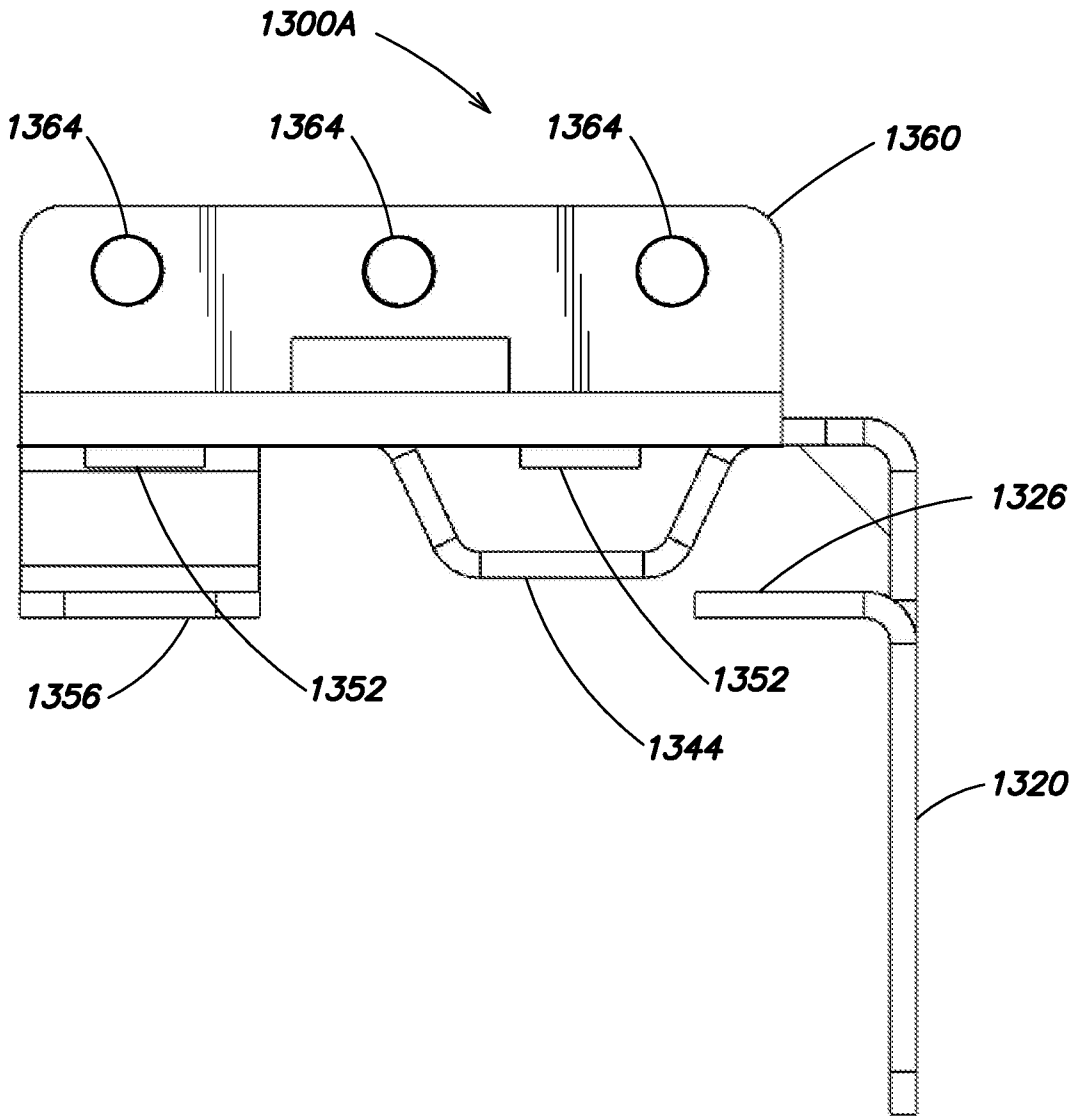


**FIG. 15E**

76/77

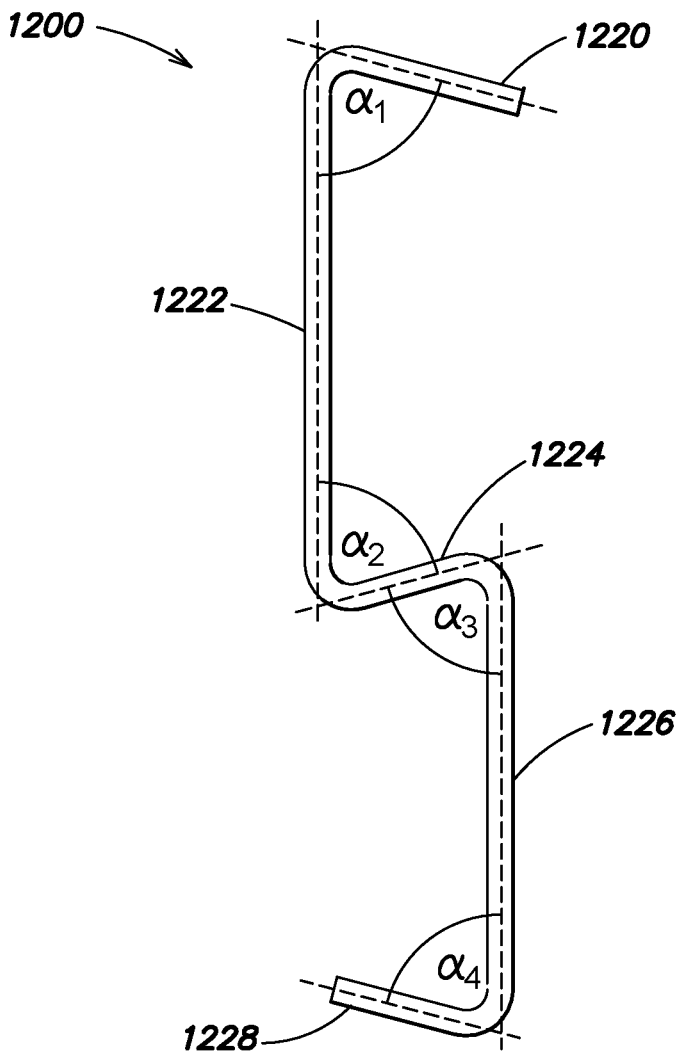


**FIG. 15F**



**FIG. 15G**





**FIG. 7B**