

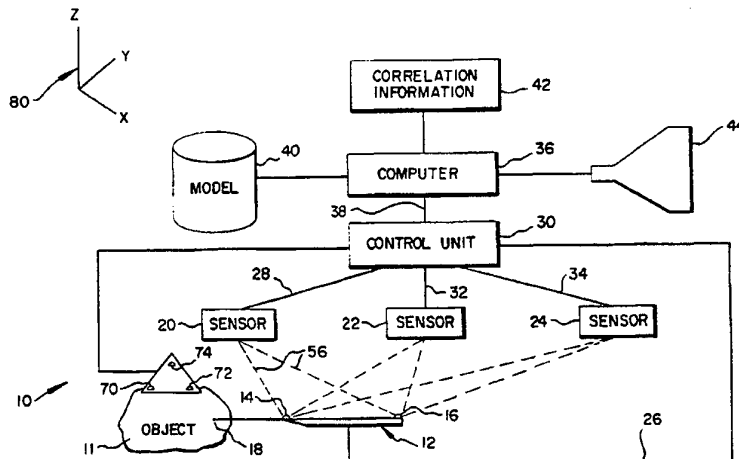

## INTERNATIONAL APPLICATION PUBLISHED UNDER THE PATENT COOPERATION TREATY (PCT)

<p>(51) International Patent Classification <sup>5</sup> : <b>A61B 5/05, G01B 11/00</b></p>	<p><b>A1</b></p>	<p>(11) International Publication Number: <b>WO 94/23647</b></p> <p>(43) International Publication Date: 27 October 1994 (27.10.94)</p>													
<p>(21) International Application Number: PCT/US94/04298</p> <p>(22) International Filing Date: 22 April 1994 (22.04.94)</p> <p>(30) Priority Data:</p> <table border="0"> <tr> <td>08/052,042</td> <td>22 April 1993 (22.04.93)</td> <td>US</td> </tr> <tr> <td>08/052,045</td> <td>22 April 1993 (22.04.93)</td> <td>US</td> </tr> </table> <p>(60) Parent Applications or Grants</p> <p>(63) Related by Continuation</p> <table border="0"> <tr> <td>US</td> <td>08/052,042 (CIP)</td> </tr> <tr> <td>Filed on</td> <td>22 April 1993 (22.04.93)</td> </tr> <tr> <td>US</td> <td>08/052,045 (CIP)</td> </tr> <tr> <td>Filed on</td> <td>22 April 1993 (22.04.93)</td> </tr> </table> <p>(71) Applicant (for all designated States except US): PIXSYS, INC. [US/US]; 5680-B Central Avenue, Boulder, CO 80301 (US).</p> <p>(72) Inventor; and</p> <p>(75) Inventor/Applicant (for US only): SCHULZ, Waldean, A. [US/US]; 440 Japonica Way, Boulder, CO 80301 (US).</p>	08/052,042	22 April 1993 (22.04.93)	US	08/052,045	22 April 1993 (22.04.93)	US	US	08/052,042 (CIP)	Filed on	22 April 1993 (22.04.93)	US	08/052,045 (CIP)	Filed on	22 April 1993 (22.04.93)	<p>(74) Agents: GILMAN, Michael, G. et al.; Nikaido, Marmelstein, Murray &amp; Oram, Metropolitan Square, Suite 330, 655 Fifteenth Street, N.W., G Street Lobby, Washington, DC 20005-5701 (US).</p> <p>(81) Designated States: AT, AU, BB, BG, BR, BY, CA, CH, CN, CZ, DE, DK, ES, FI, GB, GE, HU, JP, KG, KP, KR, KZ, LK, LU, LV, MD, MG, MN, MW, NL, NO, NZ, PL, PT, RO, RU, SD, SE, SI, SK, TJ, TT, UA, US, UZ, VN, European patent (AT, BE, CH, DE, DK, ES, FR, GB, GR, IE, IT, LU, MC, NL, PT, SE), OAPI patent (BF, BJ, CF, CG, CI, CM, GA, GN, ML, MR, NE, SN, TD, TG).</p> <p><b>Published</b></p> <p><i>With international search report.</i></p> <p><i>Before the expiration of the time limit for amending the claims and to be republished in the event of the receipt of amendments.</i></p>
08/052,042	22 April 1993 (22.04.93)	US													
08/052,045	22 April 1993 (22.04.93)	US													
US	08/052,042 (CIP)														
Filed on	22 April 1993 (22.04.93)														
US	08/052,045 (CIP)														
Filed on	22 April 1993 (22.04.93)														

## (54) Title: SYSTEM FOR LOCATING RELATIVE POSITIONS OF OBJECTS



## (57) Abstract

This system locates and displays the relative positions of one moveable object (12) with respect to a second moveable object (11) in a three-dimensional space. The locations of at least two points reference (14, 16) on the first object (12) and at least three reference points (73-75) on the second object (11) are measurable by position sensors (20, 22, 24) in a predetermined fixed coordinate system (80). From the locations of the reference points (14, 16, 73-75), a computer (36) determines the positions and orientations of the two objects (11, 12) in the fixed coordinate system (80). From the positions and orientations of the two objects (11, 12), the computer (36) further determines the relative position and orientation of the first object (12) with respect to a predetermined local coordinate system in a fixed relationship with the second object (11). The computer (36) causes the display of a graphical representation of the position and orientation of the first object (12) on a graphical model of previously taken image data of the second object (11).

**FOR THE PURPOSES OF INFORMATION ONLY**

Codes used to identify States party to the PCT on the front pages of pamphlets publishing international applications under the PCT.

AT	Austria	GB	United Kingdom	MR	Mauritania
AU	Australia	GE	Georgia	MW	Malawi
BB	Barbados	GN	Guinea	NE	Niger
BE	Belgium	GR	Greece	NL	Netherlands
BF	Burkina Faso	HU	Hungary	NO	Norway
BG	Bulgaria	IE	Ireland	NZ	New Zealand
BJ	Benin	IT	Italy	PL	Poland
BR	Brazil	JP	Japan	PT	Portugal
BY	Belarus	KE	Kenya	RO	Romania
CA	Canada	KG	Kyrgyzstan	RU	Russian Federation
CF	Central African Republic	KP	Democratic People's Republic of Korea	SD	Sudan
CG	Congo	KR	Republic of Korea	SE	Sweden
CH	Switzerland	KZ	Kazakhstan	SI	Slovenia
CI	Côte d'Ivoire	LI	Liechtenstein	SK	Slovakia
CM	Cameroon	LK	Sri Lanka	SN	Senegal
CN	China	LU	Luxembourg	TD	Chad
CS	Czechoslovakia	LV	Latvia	TG	Togo
CZ	Czech Republic	MC	Monaco	TJ	Tajikistan
DE	Germany	MD	Republic of Moldova	TT	Trinidad and Tobago
DK	Denmark	MG	Madagascar	UA	Ukraine
ES	Spain	ML	Mali	US	United States of America
FI	Finland	MN	Mongolia	UZ	Uzbekistan
FR	France			VN	Viet Nam
GA	Gabon				

## SYSTEM FOR LOCATING RELATIVE POSITIONS OF OBJECTS

This application is a continuation in part of applications serial numbers 08/052,042 and 08/052,045, both filed April 22, 1993.

### FIELD OF THE INVENTION

This invention relates to locating the position of one object relative to another object in a three-dimensional space. It more particularly refers to a system for locating and displaying the position and the orientation of a first moving object relative to a second moving object in three dimensional space.

### Description of Prior Art

Computed tomography (CT), magnetic resonance imaging (MRI), and other methods provide important detailed images of the internals of human medical patients which are useful for diagnostic purposes. Often, these diagnostic tools, which are used to determine and display images of the inside of patients' bodies, were used, and the images they create were taken at times other than during actual surgical work on the patients, that is before and/or sometimes after surgery. Specifically, it is usual for CT or MRI scans to be taken before the surgeon starts his work. They are diagnostic tools, not tools for following an operation in progress. These prior scans are then commonly used to plan the surgery or at least to assist the surgeon in deciding what surgical course of action should be initiated and then followed. Sometimes, they are also used after surgery to determine and evaluate the results of the surgical procedure.

If surgery is in areas of the body which are not

readily visible to the surgeon, such as inside the cranium within the recesses of the brain, it is difficult, if not impossible to follow the course of the surgery while it is going on. It is presently impossible to conduct surgery while simultaneously taking an MRI. Therefore, the surgeon is always working with previously taken images of the internal structures of the patient.

While working with these previously taken images during surgery, there often is no obvious, clear-cut relationship between points of interest in the diagnostic images and the corresponding points on the actual patient. While anomalous tissue may be obviously distinct from normal healthy tissue in the images, the difference may not be so visible in the patient on the operating table. Furthermore, in intracranial surgery, the region of interest may not always be accessible to direct view. Thus there exists a need for apparatus and systems to help a surgeon relate locations in the diagnostic images to the corresponding locations in the actual anatomy of the patient, and vice versa.

The related prior art includes references which disclose subject matter which describe means to accomplish objects which are similar to those of the present invention as a whole. These references include publications describing the correlation of previously taken internal medical images of a patient, which are usually three-dimensional, with the corresponding actual, present time physical locations on and in the patient in the operating room during surgery. U.S. Patent 4,791,934 describes a semi-automated system which makes this correlation, but note should be taken that the system described in this patent also requires additional radiographic imaging to be accomplished in the operating room at the time of surgery, and it then also requires that these present time images be correlated into the coordinate systems of the previously taken diagnostic images so that they can be related to the live patient.

Furthermore, the system of this '934 patent uses

a computer-driven robot arm to position a surgical tool in relation to these images. It does not measure and define the present time location and orientation of an input probe (a surgical tool) positioned interactively by the surgeon, and superimpose such present time data on a previously taken image.

There have been other attempts to solve the three-dimensional localization problem specifically for stereotactic surgery. One class of solutions has been the use of a variety of mechanical frames, holders, or protractors for surgery (usually intracranial surgery). For examples see U.S. Patents 4,931,056, 4,875,478, 4,841,967, 4,809,694, 4,805,615, 4,723,544, 4,706,665, and 4,651,732, 4,638,798. Generally these patents disclose systems which are intended to reproduce angles derived from the analysis of internal images, and most require rigidly screwing a frame to the skull. In any case, these methods are all inconvenient, time-consuming, and prone to human error.

A more interactive method is disclosed in United States patent 4,750,487. This patent discloses the use of present time fluoroscopy in the operating room to help guide surgical tools. It will be abundantly clear that subjecting a patient to fluoroscopy is undesirable at any time. It may impose even greater risks during surgery.

More relevant prior art are the publications which describe systems which have been built specifically for stereotactic surgery. The following reference is illustrative and pertinent:

David W. Roberts, M.D., et al; "A Frameless Stereotaxic Integration of Computerized Tomographic Imaging and the Operating Microscope", J. Neurosurgery 65, Oct. 1986.

This reference reports on the use of a three-dimensional digitizer to track the position and orientation of the field of view of a surgical microscope and means to superimpose, on the field of view in the microscope, the corresponding internal planar slice of a previously

obtained computed tomographic (CT) image. Such a system was a great step forward in this art. It was, however, not without attendant disadvantages.

5 In the first place, the system described by Roberts et al. used the transmission of sound impulses to communicate the location and orientation of the field of the surgical microscope. The use of sound is necessarily based on the determination of transmission distances as a function of the speed of sound, and the differentiation of  
10 small distance differences. It is well known that the speed of sound varies to a substantial extent as a function of the temperature in the medium through which the sound travels. With modern air conditioning and heating, there are many different thermoclines and air  
15 currents present in an operating room, which are of little concern to a patient or to the doctors, but which can materially effect the accurate measurement of precise distances as a function of the speed of sound transmission. Therefore very accurate compensation  
20 factors must be applied in order to get accurate information on the exact location and orientation of the operating microscope. It will be appreciated that small errors in this field can have very serious consequences to the patient.

25 It must be remembered that the purpose of measuring distances from the sound emitters to the receivers is to determine precisely where the point of a surgical probe, or other device, is. The point may move only a very short distance, millimeters or even less, and  
30 so the position of the sound emitter on the probe may change by only a very small amount. This mensuration system must be able to detect such small changes in position and orientation of the sound emitters, and to translate these small changes into meaningful changes in  
35 the defined position and orientation of the point of the probe. Thus the accuracy of measuring and knowing the speed of sound in the medium of the operating room is critical to locating the point of the probe with any

accuracy and cross correlating this location with a previously taken image which corresponds to the location of the probe tip. It should therefore be clear that the major disadvantage for this reported sonic system is the inherent inaccuracy and instability of the sonic mensuration apparatus.

In addition to the difficulty of making accurate and precise distance measurements using sound transmission, there was another difficulty and uncertainty which was inherent in the Roberts et al. system regardless of its use of sound sensing means or not. The Roberts et al. system relied on the position of the patient, at least so much of the patient as corresponded to the area being operated on—that is for example the head, being absolutely fixed. That system was not capable of determining changes in the location of the patient housing the operating microscope, but tracked only the location of the microscope independent of the patient. The location and orientation of the patient (the head of the patient) was determined at the start of the operation and the previously taken CT scan related to that specific position and orientation. If this position and/or orientation of the patient was changed, intentionally or even inadvertently, during the entire operation, the system had to be re-correlated. That is, the operation had to be stopped and the previously taken CT scan had to be correlated with the new position and/or orientation of the patient's head. Clearly this was a major disadvantage of the Roberts et al. system. Not only does it require that the system be re-correlated at the time that the surgeon intentionally moved the patient's head, but it was not capable of taking into consideration inadvertent movements of the patient's head during the operation.

The present invention does not include the taking of suitable images of the internals of a patient before the operation. It starts from the point at which these images have already been taken and are found to be acceptable by the surgeon. This invention therefore does

not comprise the imaging apparatus used to generate the internal three-dimensional image or model of the internals of the patient or other object. However, this invention does use these previous imaging data and inputs this information into the instant system. The system of this invention does not include the means of taking these images, but it does include the images themselves, preferably in electronic form.

It is contemplated that such known imaging devices might be ultra-sound, computed tomography (CT) or magnetic resonance imaging (MRI). It is also contemplated that such imaging device might be one which has as yet not been developed. The important limiting factor in the sense of the imager is that the data generated by that imager must be available in an electronic digital format, or is readily convertible into such format. The digital data may be derived directly from such an imager and transmitted to the instant system over a conventional communication network or through magnetic tape or disk media.

There is another area of prior art references which may be applicable to the patentability of the instant invention. This prior art is related specifically to localizing devices, which measure the relative positions of a manually maneuvered probe and another object, but not necessarily applied to "seeing" the present time position of the probe internal to a patient. Previous methods and devices have been utilized to sense the position of an object in three-dimensional space. These known techniques employ various methods of mensuration.

Numerous three-dimensional mensuration methods project a thin beam or a plane of light onto an object and optically sense where the light intersects the object. Examples of several United States patents which disclose such simple distance range-finding devices using this general approach are: U.S. patents 4,660,970, 4,701,049, 4,705,395, 4,709,156, 4,733,969, 4,743,770, 4,753,528,



4,761,072, 4,764,016, 4,782,239, and 4,825,091. Examples of United States patents which disclose using the plane of light to sense an object's shape include: U.S. patents 4,821,200, 4,701,047, 4,705,401, 4,737,032, 4,745,290, 5 4,794,262, 4,821,200, 4,743,771, and 4,822,163. In the latter, the accuracy of determining the location and orientation of the surface sample points is limited by the typically low resolution of two-dimensional sensors which have usually been employed (currently the accuracy of 10 these devices is about 1 part in 512 for a solid state video camera). Furthermore, these devices are not presently capable of detecting the location and orientation of the tip of a probe whereby the tip of the probe identified is coincident with specific points, and 15 identifying the location of such probe tip is synonymous with identifying such specific point. Additionally, optical systems are traditionally limited by line-of-sight considerations. If you cannot see the point in question, light cannot be directly impinged on that point or 20 projected from it. Because of these inherent limitations, these known devices have been generally useless for locating a point within a recess, which is necessary for intracranial surgery.

The internal imaging devices themselves (such as 25 computed tomography, magnetic resonance imaging, or ultrasonic imaging) are unsuited for tracking the spatial location and orientation of a manually held probe during an operation, even though they are unencumbered by line-of-sight restrictions. Thus, these systems are not 30 capable of being used to previously record an image, or a set of images, of the internals of a patient, and also to image these same internals in present time during an operation.

Other prior art methods and apparatus are known 35 which track the position of one or more specific moveable points in three-dimensional space. In these known techniques, the moveable points are generally represented by small radiating emitters which move relative to fixed

position sensors. Some methods interchange the roles of the emitters and sensors. The typical forms of radiation are light (U.S. Patent 4,836,778 for example), sound (U.S. Patent 3,821,469), and magnetic fields (U.S. Patent 3,983,474). Other methods include mechanical arms or cables (U.S. Patent 4,779,212). Some electro-optical approaches use a pair of video cameras plus a computer to calculate the position of homologous points in a pair of stereographic video images (for example, U.S. Patents 4,836,778 or 4,829,373). The points of interest may be passive reflectors or flashing light emitters. The use of light emitters tend to simplify finding, distinguishing, and calculating the location and orientation of the points.

Probes with a pointing tip and sonic localizing emitters on them have been publicly marketed for several years. The instant invention is also concerned with determining the location and orientation of a stylus, but it is an improvement over the known devices in that it employs tiny light emitters, in place of the known sound emitters. Further, as will become apparent, the method used to sense the positions of these light emitters is different from what has been used in connection with sound.

Additional prior art related to the instant invention is found in these references:

Fuchs, H.; Duran, J.; Johnson, B.; "Acquisition and Modeling of Human Body Form Data", Proc. SPIE, v 166, (1978), p 94-102.

Mesqui, F.; Kaeser, F.; Fischer, P.; "Real-time, Non-invasive Recording and 3-d Display of the Functional Movements of an Arbitrary Mandible Point", SPIE Biostereometrics 602, 1985, p 77-84.

Yamashita, Y.; Suzuki, N.; Oshima, M.; "Three-Dimensional Stereometric Measurement System Using Optical Scanners, Cylindrical Lenses, and Line Sensors, Proc. SPIE, v. 361, 1983, p. 67-73.

The paper by Fuchs, et al, (1978) best describes a method used to track a surgical probe in three-dimensional space. This method could possibly be used in conjunction with and to supplement the practice of the instant invention. It is based on using three or more one-dimensional sensors, each consisting of a cylindrical lens and a linear array of radiation detectors, such as a charge-coupled semiconductor device (CCD) or a differential-voltage position sensitive detector (PSD). The sensors determine intersecting planes which all correspond to a single point radiating light emitter. Calculation of the point of intersection of the planes gives the location of the emitter. The calculation is based on the locations, orientations, and other details concerning the one-dimensional sensors and is a straightforward application of analytic geometry. This photo-optical method, however, has not been previously used for the purpose of the present invention. In that sense, it is possible that the instant system could be considered to be a new and unobvious use of an existing system.

Thus, there still remains a need for a complete system (apparatus and method) which provides fast, accurate, safe, and convenient mensuration of the three-dimensional position and orientation of a manually operated probe relative to a moveable object of interest. This system must also visually relate, in the same coordinate system, the relative position and orientation of the probe, even a portion of the probe, which is out of line of sight, to an image of a previously-generated three-dimensional model of the object.

#### **Objects and Summary of the Invention**

One objective of the present invention is to provide means for accurate three-dimensional mensuration of the relative position and orientation of a moveable member with respect to a moveable object.

Another object of this invention is to provide accurate visual relationship between two objects which are each moveable with respect to each other as well as with respect to the coordinate system in which these movable objects reside.

A further object of this invention is to provide accurate spacial relationships between a moving probe and a moving surgical patient during an operation in an operating room, wherein the probe and the patient are moving relative to each other as well as relative to a fixed location and orientation of the mensuration apparatus.

A still further object of this invention is to provide an electro-optical mensuration system which is inexpensive, easy to use, reliable, and portable, and which employs a manually positioned probe, or other instrument, at least part of which is not within a line of sight of the surgeon, and which further employs a means of measuring the otherwise "invisible" position and orientation of the probe tip.

Another object of this invention is to provide a simple, non-invasive system for establishing a correspondence between a presently existing coordinate system containing a movable object and a previously obtained coordinate system containing a three-dimensional computer model of that object, where the previously obtained computer model is also of this same system.

Another object of this invention is to relate a measured location on the outside, or inside, of an object to its corresponding location in a previously generated computer model of that object by establishing correspondence between the coordinate systems of the object and the model.

Another object of this invention is to display a cut-away view or a cross-sectional slice of a previously generated computer model of a planar cross-section of a geometric model, where the slice approximately intersects the location in the model corresponding to a location

measured in present time, and to superimpose a marker on the displayed slice to indicate the location on the slice corresponding to the measured location.

5 Another object of this invention is to assist an operating surgeon locate subcutaneous diseased tissue while avoiding healthy critical structures, especially in cranial neurosurgery.

10 Additional objects, advantages, and novel features of the invention shall be set forth, at least in part in the following description. These will also become apparent to those skilled in the art upon examination of the following discussion or may be learned by the practice of the invention. The objects and the advantages of the invention may be realized and attained by means of the instrumentality and in the combinations particularly pointed out in the appended claims.

15 To achieve the foregoing and other objects, and in accordance with the invention, as embodied and broadly described herein, the relative position and orientation of two or more objects, moving independently of each other in space, is determined using the apparatus and the method of this invention. As used herein, a two moving-object set, which is a simple illustration of the system used in this invention, is defined as:

25 at least one first movable object, which may be a hand held probe having an invasive tip, for touching or for inserting into a second object;

at least one second movable object with respect to which the first object is movable, or is moving;

30 a present time coordinate system, that is a coordinate system which exists at the time of determining the spatial interrelationship of the several moving objects, which includes the second object, and in which said second object is moving, or can be moved;

35 a previously taken predetermined three-dimensional geometrical model, suitably a computer generated model, of the second object suitably provided in an electronically-accessible data base form;

a previous time coordinate system, which includes the previously taken computer model, that is a coordinate system which was determined at the time that the data from which the computer generated model were taken;

5 means to relate the previous time coordinate system of the previously taken model of the second object to the present time coordinate system of the second object itself;

10 at least two first radiation emitters, mounted in spaced relation to each other on a portion of the first object which, during movement of said first object relative to said second object, are not obscured from receiver(s) adapted to receive the radiation emitted thereby;

15 at least three second, additional radiation emitters, differentiatable from each other and from the first radiation emitters, which are mounted in fixed relationship to, and are movable with, the second object and which are not obscured from receiver(s) adapted to receive the radiation emitted therefrom

20 at least three radiation sensors, the positions of which are known with respect to a present time fixed coordinate system, which are so positioned that they can detect the positions of at least two of the first radiation emitters and at least three of the second radiation emitters;

25 means to differentiate between the first and second radiation emitters sufficient to be able to distinguish between the several emitters;

30 means to control the number of contacts between said first radiation emitters and said sensors per unit of time sufficient to track movement of said first object relative to said present time coordinate system in which said second object resides;

35 means to control the number of contacts between said second radiation emitters and said sensors per unit of time sufficient to track movement of said second object relative to the present time coordinate system in which it

resides without interference with the radiation emitted from said first emitters;

5 computer means coupled to the first and second radiation emitters and to the radiation sensors adapted to receive data from the sensors and from the emitters;

means to calculate, based on the data received from said emitters and said sensors, the position and orientation of each radiation emitter with respect to said present time fixed coordinate system;

10 computer means adapted to independently determine the positions and orientations of the first object and the second object relative to the present time fixed coordinate system, whereby determining the position and orientation of said first object relative to said second object, from the computed positions of the radiation emitters;

15 computer means adapted to, at a frequency which is sufficient to substantially continuously accurately relate the present time position and orientation of the first object to the position and orientation of the model of the second object, relate the present time position and orientation of the second object with the previously obtained model of the second object and to electronically cross correlate the model of said second object and the present time position of said second object so as to form one composite image of said model which is consistent with the present time position and orientation of said second object, and to superimpose the present time position of the first object on said consistent image in the present time coordinate system; and, preferably, display means coupled to the computer means adapted to display the location of the first object correctly superimposed on the model of the second object by correctly displaying a representation of the previously taken image of the second object which corresponds to the location and orientation of the second object in present time relative to the display of the first object in present time.

20

25

30

35

The method of this invention relates to the operation of the above described apparatus. This method will be described in relation to "seeing" the location of a point of a surgical probe inside the cranium of a patient, where the inside of the patient's cranium has been previously "seen" on an MRI or a CT scan. In carrying out this method, both the head of the patient, the second object according to this invention, and the surgical probe, the first object according to this invention, will be moved in illustration of the novel operation of this invention.

The method of this invention, described relative to the above described apparatus, includes the steps of:

at a previous time, taking an MRI or a CT or the like, which may hereinbelow be referred to sometimes as the previous scan, through the patient's head with a sufficient number and location of slices as to reveal the internal structures of the patient's head. Where there is an abnormality, the number and location of the slices should be sufficient to depict that abnormality in at least one slice;

establishing and storing an electronic file of the scan in the form of a model of the internals of the patient's head, including the abnormality, if there is one;

relating that electronic file to a present time coordinate system;

at the present time, as opposed to the previous time when the scan was originally taken, at sufficiently frequent intervals to accurately follow present time movement, detecting the positions of at least three of the radiation emitters operatively associated with the patient's head (the patient's head is the second object in the generic description of this invention);

at the present time, at sufficiently frequent intervals to follow present time movement, computing, from the detected positions of these emitters, the moving



locations and orientation of the second object relative to the predetermined fixed coordinate system;

electronically adjusting the stored model to display a view of that model which corresponds to the computed present time location and orientation of the moving second object in the same present time coordination system;

at the present time, at sufficiently frequent intervals to follow present time movement, detecting the locations of at least two of the radiation emitters operatively associated with the probe (the probe is the first object in the generic description of this invention);

at the present time, computing, from the detected positions of these emitters, at sufficiently frequent intervals to follow present time movement, the position and orientation of the first object in present time relative to the predetermined fixed coordinate system;

at sufficiently frequent intervals to track the movement of the first object relative to the second object, determining the positions and orientations of the first object relative to the second object by correlating the positions and orientations of the first object relative to the predetermined fixed coordinate system with the positions and orientations of the object relative to the same predetermined fixed coordinate system;

determining the correlation between the relative position and orientation of the probe with respect to the model of the object; and indicating the location of the probe with respect to the object by displaying a representation of the position and orientation of the probe in present time on the presently displayed model of the previously taken scan of the internal structures of the cranium.

In the description of this invention, the radiation emitters have been located on the first and second objects, and the sensors for these radiations have been located in fixed positions within the present time coordination system. It is considered that this

arrangement of these emitters and sensors could readily be reversed. That is, the emitters could occupy the fixed positions in the present time coordination system and the sensors could be located on the first and second objects.

5 The invention would operate in the same manner with either arrangement of sensors and emitters. For convenience, the description of this invention has placed the emitters on the moving objects and the sensors in fixed positions. This arrangement should not be considered to be a

10 limitation on either the apparatus or method of this invention.

#### **Brief Description of the Drawings**

The accompanying drawing figures illustrate a preferred embodiment of the present invention and, together with the description, serve to explain the principles of the invention.

15

Figure 1A is a block flow diagram of the optical mensuration and correlation system of the present invention showing the major components of this system, except for the means to automatically measure the position and orientation of the movable and second object.

20

Figure 1B is similar to Fig. 1A but includes the additional radiation emitters which will permit automatically measuring the position and orientation of the second object even during the movement of this second object.

25

Figure 2 is a perspective view illustrating the invention in use by a surgeon performing intracranial surgery on a patient, and showing a cursor on a display screen that marks the corresponding position of the tip of the probe (the first object) within the image of previously obtained model data corresponding to the cranium (the second object).

30

Figure 3 is a view of a sample display showing a position of the tip of the probe superimposed on previously obtained model data of an inside slice of a cranium and the showing reference points of the second

35

object, as depicted in figure 1A, as triangles on the patient's skull.

Figure 4 is a schematic perspective view of a sample of one of the one-dimensional photodetectors which are useful in the practice of the present invention.

Figure 5 is a graph of the image intensity (manifested as a voltage or current) versus locations on the photodetector surface for a typical light detector which could be used by the radiation supported mensuration and correlation apparatus of the present invention.

Figures 6 and 7 are diagrams of the major steps performed by the computer to calculate the position of the probe (first object) with respect to the model of the inside of the cranium (the second object) and to display a cross-sectional image slice of the model of the inside of the cranium on a suitable display screen, such as a computer screen (CRT).

Figure 8 is a schematic view of radiation beams depicting an embodiment of this invention.

#### **20 Detailed Description of The Preferred Embodiments of This Invention**

The radiation mensuration and correlation apparatus 10 of the present invention, as applied to a medical application, which is illustrative of one use of this invention, is shown schematically in Figure 1. It comprises a hand-held invasive probe 12 (first object) housing at least two radiation emitters 14 and 16 mounted collinear with one another and with the tip 18 of the probe 12. At least three remotely located, one-dimensional radiation sensors 20, 22, and 24 are mounted in fixed, spaced relationship to each other and are located at known positions with respect to a predetermined fixed coordinate system 80. The radiation sensors 20, 22, and 24 sense the radiation widely projected by the individual emitters 14 and 16 and generate electrical output signals from which are derived the location of the probe emitters 14 and 16 and, consequently the position and orientation of the probe tip 18 (which may not be

visible to the surgeon because it is within the cranial cavity), with respect to the fixed coordinate system 80. In addition, where it is desired to determine the moving position of the cranium during the operation, the three  
5 sensors 20, 22, and 24 can be programmed to sense and derive the locations of other reference emitters 70, 72, and 74 on the second object 11 (Figure 1B) in the same manner as for the probe emitters 14 and 16. The role of these reference emitters on the second object is to  
10 automate the calculation of the relationships between the present time coordinate system of the model's image 13 (Figure 2) of the second object, the coordinate system of the sensors, and the local coordinate system of the second object itself 11.

15 A control unit 30 connected to the moveable probe 12 via a data line 26 and coupled to the remotely located sensors 20, 22, and 24 via data lines 28, 32, and 34, respectively, synchronizes the sensing of the five (exemplary) emitters and the differentiation between them.  
20 In that embodiment of this invention where the various emitters emit radiation in pulses, as by strobing them, the control unit is adapted to control the time multiplexing of the two emitters 14 and 16 on the probe and the three emitters 70, 72 and 74 on the cranium,  
25 controls the operation of the sensors 20, 22, and 24, and receives differentiable data from these sensors as will be more completely described below. A coordinate computer 36, coupled to the control unit 30 by a data line 38, calculates the three-dimensional spatial location of the  
30 probe emitters 14 and 16 and consequently the position and orientation of the probe tip 18, and correlates those positions with data from correlation information 42 and from a model 13 of the second object 11 which has been previously stored electronically in an electronically  
35 accessible database 40. Finally, the computer 36 causes an associated cathode ray tube-monitor (CRT) to display the representation of the position and the orientation of the probe tip 18 with respect to the computer image 13 of

the cranium 11 on display screen 44 (Figure 2) as will be more fully described below.

5 The probe 12 could be used without the cable 26, in that it could be coupled to the control unit 30 by employing distinctive modulation of the light emitters 14 and 16 instead of sequentially energizing (strobing) them, or by varying the wavelength or type of the radiation emitted therefrom. For example, the wave forms, color, or frequencies of each could be different. In the case of  
10 using sound radiation, the frequencies of the sound emitted by the different emitters could be varied so as to differentiate between them. The controller 30, by detecting the differences between different emitters, that is the wave form, color, frequency or other dissimilarity,  
15 of the emitted radiation, can determine to which emitter the sensors 20, 22, and 24 are reacting.

The fundamental mensuration and correlation apparatus 10 of the present invention has been illustrated in connection with aiding surgeons performing delicate  
20 intracranial surgery. This general use of this apparatus does not constitute this invention, nor is it a limitation thereon. This use will only serve to illustrate this invention. The remaining description continues to use such a surgical embodiment as illustrative, although many  
25 other surgical or other applications besides intra-cranial surgery are possible (for example, back or sinus surgery and breast biopsy). Moreover, the radiation mensuration and correlation apparatus 10 of this invention may be used  
30 for other purposes in many various medical or non-medical fields. In the described embodiment, the physical object 11 of interest, that is the second object in the generic application of this invention, is the head or cranium of a patient, and the model of the cranium is replicated using a series of parallel internal image slices (of known  
35 mutual spatial relationship) such as those obtained by means of computed tomography (CT) or nuclear magnetic resonance imaging (MRI). These image slices are then digitized, forming a three-dimensional computer model of

the patient's cranium which is then stored in the electronically accessible database 40.

As shown in Figures 1A, 1B, 2, and 3 a surgeon places the tip 18 of the probe 12, that is the first  
5 object, at any point on or inside the cranium 11 of the patient. The position sensors 20, 22, and 24 detect the locations of the emitters 14 and 16 attached to the portion of the probe 12 that remains outside the patient's body. In order to accomplish this, the radiation produced  
10 by the emitters 14 and 16 must be "visible" to the sensors 20, 22, and 24. For that reason, more than two emitters may be placed on the first object so that the radiation from at least two of them will always be visible to the sensors. These emitters 14 and 16 are effectively point  
15 sources and radiate energy through a wide angle so that this radiation is visible at the sensors over a wide range of probe orientations and positions.

The sensors 20, 22, and 24, the control unit 30, and the computer 36 cooperate to determine the three-  
20 dimensional location of each emitter 14 and 16 within a coordinate system, and compute the coordinates of each emitter in the predetermined fixed coordinate system 80, in present time. The computer 36 can then calculate the position and orientation of the tip 18 of the probe 12  
25 with respect to the predetermined fixed coordinate system 80, according to the locations of the emitters within the fixed coordinate system 80 and the dimensions of the probe, which dimensions had been placed into the memory (not shown) of the computer 36 beforehand. It should be  
30 noticed that the computer 36 can also easily compute position and orientation information about other specific locations on the probe (such as the vector from emitter 14 to the tip 18). Once the computer 36 has calculated the location of the probe tip 18 with respect to the fixed  
35 coordinate system 80, the computer 36 then uses the relationship between the model of the cranium, which had previously been obtained and stored in the database 40, and the fixed\_coordinate system 80 to calculate the

position and orientation of the probe tip 18 in relation to the model of the second object 11. Finally, the computer 36 displays a representation of the model-relative position and the orientation of the tip 18 on a display screen 44. In a simple form of the preferred embodiment of this invention, the computer 36 accomplishes this display by accessing a previously taken CT or MRI image slice 13 stored in the database 40 that is closest to the present time position of the probe tip 18, and then superimposes a suitable representation 76 of the tip 18 on the image 13 as shown in Figures 2 and 3. Thus, the surgeon knows the precise position and orientation of the tip 18 in the patient's cranium relative to the image data by merely observing the display screen 44. A most preferred form of the present invention can derive and display an arbitrary oblique cross-section through the multiple image slices of the MRI, etc, where the cross-section can be, for example, perpendicular to the probe orientation.

The details of the optical mensuration and correlation apparatus 10 of the present invention are best understood by reference to Figures 1 and 4 collectively. Essentially, the probe 12 supports the two radiation emitters 14 and 16, which are rigidly attached to the probe 12 at fixed, known distances from each other as well as from the probe tip. Since only two emitters are used here as being representative of the practice of this invention, the emitters 14 and 16 should preferably be collinear with the tip 18 of the probe 12 so that the computer 36 can determine uniquely the position and orientation of the tip 18 in three dimensions. Moreover, for reasonable measurement accuracy, the emitters 14 and 16 should preferably be at least as far from each other as the nearest one is from the tip 18. In any case, the geometrical relationship of the emitters 14 and 16 to each other and to the probe tip 18 must be specified to the computer 36 beforehand so that the computer 36 can compute the exact location of the tip 18 based on the locations of

the individual radiation emitters 14 and 16. The use of three or more non-collinear emitters would not require that any two of them to be collinear with the probe tip. Three or more non-collinear emitters would permit the computer to compute full position and orientation information (yaw, pitch, and roll) for the probe. Although the invention is described as showing only a cursor locating the relative position of the probe tip 18, the invention can be modified to display a line or a shaped graphic or other icon to indicate the position and orientation of the probe 12. This would entail only the determination of additional points on the probe in the same way that the tip of the probe is located.

The two radiation emitters 14 and 16, as well as the additional radiation emitters 70, 72, and 74, can be, and preferably are, high intensity light emitting diodes (LEDs), which are preferably coordinated such that the emission for any one source is distinguishable from the emissions from the other sources. One such differentiation is to have the emitters time-multiplexed or strobed by the control unit 30 in a predetermined sequence such that only one light emitter is "on" or emitting light at any one time. The light emitted from any one of these emitters is detected by each of the three light sensors 20, 22, and 24, which then determines the location of each particular emitter in relation to the known positions of the sensors 20, 22, and 24 at the time it is strobed.

Each of the one-dimensional sensors 20, 22, and 24 used in the preferred embodiment 10 of the present invention can be identical to the others in every respect. Therefore, for the purpose of giving a detailed description of this embodiment, only the sensor 20 is shown and described in detail in figure 4 since the remaining sensors 22 and 24 are identical.

In Figure 4, the representative one-dimensional sensor 20 comprises a cylindrical lens 46 having a longitudinal axis 48 which is orthogonal to the optical



axis 50 of the sensor 20. A linear radiation detector 52, such as a charge coupled device (CCD) with several thousand elements (or a similar device capable of linear positional radiation detection of a suitable "image"), is positioned in such a manner that the "optical" axis 50 passes through the center of the aperture 54 of the radiation detector 52 and such that the longitudinal axis of the aperture 54 is orthogonal to the longitudinal axis 48 of the lens 46. Radiation, such as light beams, 56 from the emitters 14 (and in the same manner emitters 16, 70, 72, and/or 74) are focused by the cylindrical lens 46 into a real image line 58 on the surface 60 of linear detector 52.

The detector, illustrated by a photodetector 52, then generates an output 68 (Figure 5) that is related to the position of a real image line 58 on the surface 60 of photodetector 52, thus characterizing the location of the image itself. That is, those elements or points of the photodetector 52 illuminated by the real image line 58 will generate a strong signal, while those not illuminated will generate none or very weak signals. Thus, a graph of image intensity (or signal strength) versus locations on the surface of the photodetector will resemble a signal peak curve 68 (see for example Figure 5). The "all-emitters-off" (or background) signal level 66 is never quite zero due to the effects of environmental radiation, such as light in the operating room, electronic noise, and imperfections in the photodetector. In any event, since the image of the illuminated emitter is focused into line 58, only the angular displacement of emitter 14 from the optical axis 50 in the plane of the longitudinal sensor axis 54 is measured by the sensor 52, hence the designation "one-dimensional sensor".

Thus, a single one-dimensional sensor 20 can only locate the plane on which a radiating emitter 14 lies. The detector 20 cannot, by itself, determine the unique point in space on that plane at which radiating emitter 14 is located. To precisely determine the

location in space of the radiating emitter 14 requires at least three such sensors positioned in spaced relationship to each other, since the intersection of three planes defined by the three sensors, respectively, are required  
5 to define a single point in space.

To locate the position of one particular radiating emitter, such as 14, the sensors 20, 22, and 24 are mounted so that the optical axes of their lenses 48 are not all parallel and no two of such axes are  
10 collinear. In a preferred embodiment of this invention, two light sensors, such as sensors 20 and 24 in Figure 2, are situated so that their respective axes 48 (Figure 4) are in parallel, spaced relationship, and the third detector 22 is situated between and equidistant from the  
15 other two detectors, but with its axis 48 perpendicular to the axes of the other two. That is, the sensors 20, 22, and 24 should be arranged along a line or arc (Figure 2), such that each sensor 20, 22, and 24 is generally equidistant from the center of the volume in which the  
20 measurements are made, equally spaced from each other, and all aimed at the center of the measurement volume. Suppose for example that the sensors 20, 22, and 24 are arranged along a horizontal arc and the optical axes of all sensors are oriented horizontally. Then the middle  
25 sensor should be oriented so as to measure the angular elevation of the radiation emitters as described above. The two outer sensors measure the horizontal angle (azimuth) relative to the fixed coordinate system 50. Data from the outer sensors are used to stereographically  
30 calculate both the horizontal position and distance from the sensors as will be more fully described below.

The accuracy of three-dimensional measurement depends on the angle formed between the optical axes of the outer two sensors 20 and 24, where the emitter to be  
35 measured is at the vertex of the angle. Accuracy will improve as that angle approaches a right angle. At least three of the several possible sensors 20, 22, and 24 must be spaced so that the desired measurement volume is

completely within their field of view which can be accomplished by making the focal length of the lens 46 short enough to provide coverage of the entire desired field of view. In another embodiment of this invention, additional sensors, which may be substantially identical to sensors 20, 22, and 24, could be used to provide more viewpoints, to broaden coverage of the field of view, or to enhance measurement accuracy.

While this process of detecting a given radiating emitter, such as 14, can determine the exact location of the radiating emitter, it cannot by itself determine the particular orientation and position of the probe or its tip 18 in three-dimensional space. To do so with only two emitters requires that both emitters 14 and 16 be collinear with the probe tip 18, as described above. Also, the distances between each emitter, 14 and 16, and the probe tip (as well as the distances between the emitters 14 and 16 themselves) must be known and loaded into the memory of the computer 36 before the computer 36 can determine the position and orientation of the probe tip 18 from the locations of the emitters 14 and 16 in the fixed coordinate system 80. Consequently, when each of the radiation emitters 14 and 16 is rapidly turned on in sequence, or strobed, the sensors 20, 22, and 24 can detect the exact location of each emitter in turn. Thus computer 36 can determine the exact position and orientation of the probe, and therefore its tip 18. Since only one of the radiation emitters 14 or 16 is on at any one time, the detectors 20, 22, and 24 locate the location of that particular illuminated emitter individually. If the strobe rate, that is, the frequency at which the emitters 14 and 16 are turned on and off in sequence, is fast enough, the detectors 20, 22, and 24 can, for all practical purposes, determine the position and orientation of the probe 12 and its tip 18 at any instant in time, and therefore can follow the movement of the probe tip in present time, that is during the time that the probe tip is actually moving. In other words, this system can

simulate the movement of the probe tip on the previously taken image in present time during the surgical procedure.

The sensors 20, 22, and 24 need only distinguish which of the radiation emitters 14, 16, 70, 72, or 74 is on at any one time. In the preferred embodiment 10 of the present invention, this function is accomplished by strobing each of the emitters in sequence, as described above. However, other methods can be used to allow the sensors 20, 22, and 24 to distinguish the respective radiation emitters 14, 16, 70, 72, and 74 from one another. For example, different wave lengths (colors) of light, or different frequencies of sound, could be used in conjunction with detectors capable of distinguishing those particular different radiations.

Alternatively, it is one aspect of this invention to modulate each of the respective radiation emitters 14, 16, 70, 72, and 74 with a unique wave form or pulse train. This means of differentiating between the different emitters is believed to be novel and unique to the instant invention. If such different wave forms or pulse trains are used to differentiate the different emitters, it is also within the spirit and scope of this invention to transmit additional information on these wave forms, such as for example the temperature of the particular structure being contacted by the probe tip 18. It is within the scope of this invention to provide means readily accessible to the surgeon or other operator to engage or disengage the taking of such additional information and the transmission thereof by the unique wave forms or pulse trains radiated by the respective emitters. Under these circumstances, the control unit 30 or computer 36 will be designed to demodulate the wave form to determine to which particular emitter the sensed signal belongs, and to decode the additional information being transmitted.

Numerous other methods for distinguishing the radiation emitters are possible. Therefore, the present invention should not be regarded as limited to the

particular strobing method shown and described herein, but is generic to the use of any means to differentiate between the different emitters.

5 Conventional or unique auto-focusing or multiple-lens radiation detection may be integrated into the sensors 20, 22, and 24 to improve the performance of the system. However, the simple, fixed-focus optics shown and described herein and shown in Figure 4 for one sensor provide a good level of performance if the working range of the probe is restricted. Even if the real image of an emitter, such as 14, is somewhat out of focus on the detector 52, the angular measurement of the image is still usable. A usable measurement for each of the sensors 20, 22, or 24 to generate will be any of the following: (1) 10 the position of the detector element with peak intensity, (2) the intensity-weighted average (centroid) of all over-threshold elements, or simply (3) the average of the minimum and maximum elements where the intensity is over some threshold. The detector 52 should be placed at the focal distance for the farthest typical operating distance of the radiation emitters. Closer emitters will form slightly defocused images 58, but they require less precise angular measurement for a given distance accuracy. Furthermore, their de-focused real images are brighter, 15 which increases the brightness gradient at the edges of the image.

As described so far, the real image 58 of the currently activated emitter must be significantly different from (for example brighter than) the rest of the radiation falling on the sensor 52. Otherwise, other lights or reflective surfaces in the field of view of the sensors will hinder the detection of the emitter's real image. Therefore, it is desirable to include in the apparatus, circuitry to subtract the background radiation received by the sensors from other, ambient, sources. 20 25 30 35

This per se known circuitry enhances use of the invention where the sensors are required to detect the radiation emitters against relatively bright backgrounds.

While the radiation emitters are all momentarily extinguished, the one-dimensional data from each sensor are saved in a memory. This can be done in an analog delay line or by digitally sampling the output signal and storing it in a digital memory. Then, as each emitter is "viewed" sequentially, the saved data are subtracted from the current data generated by the currently radiating emitter. If the background data are stored digitally, the current data are also digitized, and the stored background data are digitally subtracted from the current data.

A graphical representation of the radiation intensity of the image or, equivalently, the generated output voltage amplitude for each element in a row of detecting elements, is shown in Figure 5. The graph depicts typical background image intensities 66 with all emitters off, the intensities 68 with one radiation emitter on, and the element-by-element difference 64 between the intensities with the emitter off and those with it on. The measurements will likely contain some random noise, electronic or otherwise, and two consecutive measurements for a given sensor element may differ slightly even where the background is unchanged. Therefore, the differential intensities 64 between two consecutive measurements also contain some random electronic noise. However, the two measurements differ substantially only at the location of the radiation emitter image, and this difference exceeds the threshold level 62.

The details of the structure and operation of the control unit 30 are best seen in Figure 6. Specifically, control unit 30 (see Figure 1A and 1B) supplies power to the radiation emitters 14, 16, 70, 72, and 74 and the radiation sensors 20, 22, and 24. A control and synchronization unit 84 and radiation source sequencer 88 (where a strobed radiation sequencing is used) time-multiplexes or strobes the radiation emitters individually, as described above, so that the position and orientation of the probe tip 18 (Figure 1) can be

determined from the signals received from the sensors 20, 22, and 24. The angular data signals received from the sensors 20, 22, and 24 are converted by an analog-to-digital converter 92. Actually, three analog-to-digital converters are used, as shown in Figure 6, but only one is labeled and described herein for brevity, since the other two analog-to-digital converters are substantially identical and are used to convert the signals from the other sensors 22 and 24.

5  
10 The control and synchronization unit 84 also controls three switches, of which switch 93 is typical, which store all digital data received from the sensors 20, 22, and 24 when the radiation emitters 14 and 16 are off and stores these data into a background memory 94. Then, when the radiation emitters 14, 16, 70, 72, and 74 are illuminated in sequence by radiation source sequencer 18, the synchronization and control unit 84 changes the state of switch 93 which then redirects the data from the three sensors 20, 22, and 24 to a subtraction unit 91. The subtraction unit 91 subtracts the background data from the emitter radiation data, thus resulting in a signal which has been relatively freed from the background signal 66 (Figure 5) since the fixed pattern noise has been subtracted from the signal.

15  
20  
25 As shown in Figure 6, which should be considered in conjunction with Figure 5, a 1-D (one-dimensional) position calculation unit 95 determines the location of the real image line 58 on the CCD sensor 52 (Figure 4) by measuring the locations of the edges 67 and 69 of the signal blip 68 (Figure 5) generated by the CCD sensor based on a predetermined threshold signal level 62. The 1-D position calculation unit 95 then averages the distance between the two edges to find the center of the signal peak 68 as shown in Figure 5. This method of determining the center of the signal peak is per se well known in the art and need not be described in further detail. Moreover, numerous other methods of determining the location of the signal peak or its centroid are known

30  
35

in the art and will be obvious to those of ordinary skill in the art. The method used depends on the signal characteristics of the radiation sensor used as well as the characteristics of the lens system used to focus the radiation onto the surface of the detector, in addition to other parameters. Those practicing this invention with the various alternatives described herein would have no trouble selecting a signal detection algorithm best suited to the particular characteristics of the sensors and the particular radiation being used.

Finally, the control unit 30 (Figure 1) transmits the radiation data to the computer 36. That is, when the computer 36 is ready to compute the current location of the currently radiating emitter, such as 14, the latest angular data from all sensors 20, 22, and 24 are provided for analysis. If the sensors generate data faster than the control unit 30 can process them, the surplus angular data are simply discarded.

The operation of the computer 36 is most advantageously set forth in Figure 7. The computer 36 calculates one-dimensional positions for each radiation emitter such as 14 or 16, based on the location of the signal peak from each respective sensor 20, 22, and 24. These one-dimensional angular position measurements are then used to determine the three-dimensional spatial coordinates of the emitters 14 and 16 and thus for the position and orientation of the probe 12 relative to the predetermined fixed coordinate system 80 by coordinate transformation methods which are per se well-known in the art. The output signals from the computer 36 can be in any form desired by the operator or required by the application system, such as XYZ coordinate triples based upon the predetermined fixed coordinate system 80.

Figure 8 and the following paragraphs describe in detail how the location of a single radiation emitter, such as 14, is computed from the data derived from the sensors 20, 22, and 24. The following description applies to these three sensors 20, 22, and 24 only. If there are



more than three such sensors, the calculation can be performed using any three or more of the sensors. Furthermore, if more than three sensors are used, the average of the points calculated from all combinations of three sensors could be used to increase accuracy. Another option is to use the point calculated from the three sensors closest to the radiation emitter 14 or 16. The following parameters are considered to be known XYZ constants:

10           D0[i], one endpoint of each linear photodetector i;  
              D1[i], the other endpoint of linear photodetector i;  
              L0[i], one endpoint of the axis of each lens i; and  
              L1[i], the other endpoint of the axis of lens i.

Each sensor generates T[i], a parametric value between 0 and 1 indicating where the peak or center of the line image of the emitter intersects the line segment between D0[i] and D1[i]. The XYZ coordinates of point S are to be calculated, where S is the location of the radiation emitter. For a CCD radiation detector array, T[i] is the index of the element on which the center or peak of the image falls divided by the number of elements on the detector array.

The three-dimensional coordinates of the above points are all referenced to a predetermined fixed coordinate system 80. The cylindrical lens and linear photodetector do not directly measure the angle A of the radiation emitter about its lens axis; rather, they measure a value T[i] linearly related to the tangent of that angle:

$$30 \quad \tan(A) = C * (2 * T[i] - 1),$$

where C is a constant of proportionality that is related to, and determined empirically by, the dimensions of a particular system.

The three-dimensional location of the image line on the linear photodetector is:

$$D[i] = (1 - T[i]) * D0[i] + (T[i]) * D1[i]$$

If the lens is ideal, then S also lies in plane P[i]. In reality, the point D[i] might have to be computed by a non-linear function F(t) that corrects for non-linear aberrations of the lens or the photodetector:

$$D[i] = (1 - F(T[i])) * D0[i] + (F(T[i])) * D1[i]$$

Function F(t) could be a polynomial in variable T, or it could be a value interpolated from an empirically determined table.

P[i] is the unique plane determined by the three points D[i], L0[i], and L1[i], which are never collinear. S is the point of intersection of the planes P[1], P[2], and P[3] determined respectively by sensors 1, 2, and 3. S is a unique point if at least two sensor lenses longitudinal axes are not parallel and if no two lens axes are collinear. The intersection point is found by finding the common solution S of the three equations defining the planes P[i]. Once the location S of each of the probe's radiation emitters is computed, the location of the probe's tip can be calculated. The method of making such a determination is well known using the teaching of analytic geometry and matrix manipulations.

If M is a linear transformation describing the relationship between a point R in the image coordinate system and a point S in the fixed coordinate system, then:

$$R * M = S.$$

If  $M^{-1}$  is the inverse of M and if S is a point in the fixed coordinate system, then the point R in the image coordinate system corresponding to S is:

$$S * M^{-1} = R.$$

Now, suppose that the second object is moved in the

mensuration coordinate system. This can be described by a linear transformation U where the coordinates S of a point are mapped to the coordinates S':

$$S * U = S'$$

5 Then the old value of M above must be multiplied by U in order to correct the relationship between the point R in the image coordinate and the corresponding point in the mensuration coordinate system because of the relative movement of first object with respect to the second  
10 object:

$$R = S' * U^{-1} * M^{-1}$$

The preliminary steps required before practicing the method of the invention are now described. Then, after fully describing these preliminary steps, the detailed  
15 steps of the method of the optical mensuration and correlation apparatus are described.

Use of the invention takes place in three phases: the imaging phase, the correlation phase, and the normal operation phase. The imaging phase precedes the  
20 normal operation of the present invention. During the imaging phase, a scan of the body of the second object of interest is used to build a three-dimensional geometrical model. In the preceding description, the second object was the head of a human intracranial surgical patient  
25 because the invention is advantageously used in stereotactic neurosurgery. Accordingly, the three-dimensional model comprises digital data from a series of internal cross-sectional images obtained from computed tomography (CT), magnetic resonance (MRI), ultrasound, or  
30 some other diagnostic medical scanner. In any case, the image data are stored in a suitable, electronic memory 40 which can be accessed later by the computer 36. The data are considered to be stored as a series of parallel two-dimensional rectangular arrays of picture elements

(pixels), each pixel being an integer representing relative density. If the object is relatively rigid, like a human head, this three-dimensional model may be created at some time before the correlation and operational phases of the invention and possibly at another location.

Also, during the imaging phase, at least three non-collinear reference points 71, 73, and 75 (Figures 2 and 3) must be identified relative to the object 11. These may be represented by ink spots, tattoos, radiopaque beads, well-defined rigid anatomical landmarks, locations on a stereotactic frame, sterile pins temporarily inserted into rigid tissue or bone of a surgical patient, or some other reference means. The coordinates of these reference points are measured and recorded relative to the coordinate system of the imaging device. One way to accomplish this is to capture the reference points as part of the previously made three dimensional model itself. For example, radiopaque pins could be placed within the image planes of diagnostic CT slices; the pin locations, if not automatically detectable from their high density, can be identified interactively by the surgeon using a cursor on the computer display of the CT slices. See Figure 3.

The initializing of the position and the orientation of the second object, the patient's cranium, is well known in this art. The instant invention departs from this well known operation to add radiation emitters which have a known and exact spacial relation to these fiducial markings. These additional radiation emitters must then be programmed or otherwise activated for use in a particular manner in order to practice the instant invention. They must be programmed to radiate at some frequency during the surgical procedure which is in progress during present time so that the position and orientation of the second object will be available to the surgeon at all relevant times and so that this position and orientation can be repeatedly and automatically updated in order for the system to revise the specific

selected scan slice to superimpose the position and the orientation of the first object on in a correct depiction of the actual relative positions and orientations of both the first and second object in present time during the surgical procedure.

5 The initial correlation mode immediately precedes the normal operational phase of the present invention and must take place in the operating room. During this initial correlation phase, the instant system  
10 accesses the data of the three-dimensional geometrical model of the patient (or other object), including the reference point (fiducial marker) coordinates which were recorded earlier, that is previously. Next, the surgeon may place the tip of the probe 18 at each of the reference  
15 points 71, 73, and 75 on the patient, in turn. This sequence of operations may be directed by the computer program. In the alternative, the system of this invention provides these data automatically by the radiation from the emitters 70, 72, and 74 being received by the sensors  
20 directly and automatically without special intervention by the surgeon. Either of these procedures establish an initial relationship between the locations of these reference points in the model coordinate system and their current physical locations in the fixed coordinate system  
25 80. However, the preferred determination of this initial position and orientation also carries on during the whole of the surgical procedure and therefore is capable of substantially continuously updating the position and orientation of the second object and relating it to the  
30 current position and orientation of the probe. In turn, this establishes a linear mathematical relationship between all points in the model and points in the coordinate system 80. Thereafter, when the patient is moved relative to the sensors, the prior art must  
35 establish a new relationship by again digitizing the reference points 71, 73, and 75 within the coordinate system 80. That is, the correlation phase must be repeated. Again, the system of this invention uses the

emitters 70, 72 and 74 to accomplish this automatically. For this reason, the automatic tracking of the position of the head, or the second object whatever that is, which is described below and which overcomes this problem, is an essential, significant feature of the present invention.

5 Since the position and orientation of the head is initially and substantially continually thereafter correlated with the model, the surgeon can relate any locations of interest on the diagnostic images with the corresponding physical locations on this patient during the operation, and vice versa. These include locations accessible to the probe tip 18 but not necessarily directly visible to the surgeon.

15 Having described the function and purpose of the preliminary steps, the detailed method of the present invention is more easily understood. As shown in Figure 7, the position data 21 of the probe emitters generated by the sensors and control unit are converted into three-dimensional coordinates relative to the predetermined fixed coordinate system 80 of the sensors. Using dimensional parameters describing the relationship among the probe emitters and the probe tip, the computer determines the coordinates of the probe tip in a step 39. During the initial correlation phase, the probe tip may be placed at each of the reference points 71, 73, and 75 in turn. Alternatively, in accord with a preferred aspect of this invention, the emitters 71, 73 and 75 are located by the sensors and the correct position and orientation of the second object is thereby determined. The coordinates of the second object in the fixed coordinate system along with their coordinates 46 in the image coordinate system determine a unique linear transformation relating the two coordinate systems in a step 45. This is a per se known calculation in analytic geometry and matrix mathematics.

35 As noted above, a more automated and direct method of determining the location of the second object is to directly read the locations of the fiducial points 71, 73 and 75 by the fixed sensors 20, 22 and 24. This can be

accomplished by placing radiation emitters 70, 72, and 74 (Figure 1B) at those reference points (or in a known fixed spacial relationship to those reference points 71, 73, and 75). The emissions of these emitters can then be read  
5 directly by the sensors 20, 22, and 24, and thus the computer can then automatically determine their locations relative to the predetermined fixed coordinate system 80 of the sensors. Thus the position and orientation of the second object, the cranium in the preferred embodiment of  
10 this invention, can be automatically and substantially continuously determined. With the position and orientation of the second object being at least frequently, if not substantially continuously, updated, the position of the first object, the probe, which is also  
15 determined at least frequently, if not substantially continuously, can then be updated in relation to the second object at the same frequency. Since the position and orientation of both the first and the second objects are each at least frequently determined and updated in  
20 relation to the fixed coordinate system 80, the position and orientation of each of these first and second objects can then be determined relative to each other, by indirect, but well known, calculations which are easily carried out in short order by a computer.

25 It has been stated herein that the position and orientation of the second object, the cranium, can, according to this invention, be determined continuously or at least frequently. The frequency at which the position and orientation of the second object is determined is a  
30 function of the desires of the operator of this system and the frequency at which the radiation emitters and the sensors can be operated. In the case where the emitters all emit the same wave length of radiation and the sensors all sense this same wave length of radiation, the  
35 differentiation of the emissions of the several emitters is followed in a sequential pattern. Thus, in this embodiment of this invention, the emitters will emit radiation in sequence, for example 14, then 16, then 70,

then 72 and then 74. The sensors will have been programmed to identify a signal with an emitter as a function of when the signal is received.

5 In this embodiment of this invention, the position and orientation of the first object, the probe, is determined with the same frequency as is the location and the orientation of the second object, the cranium, because all of the emitters radiate in sequence. However, the system can be programmed so that the emitters 14 and  
10 16 fire more or less frequently than the emitters 70, 72 and 74. Under these conditions, the position and orientation of the first object and of the second object will be determined at different individual frequencies, that is at the same frequency as the frequency of the  
15 radiation from their respective emitters. It will therefore be clear that the frequency of determination of the location of any given emitter, and therefore the determination of the position and orientation of these first and second objects, is, because of the instant  
20 invented system, for the first time entirely controllable by the programmer or the operator, within the capabilities of the system operating the emitters.

However, it should be understood that the position and orientation of the first and/or second  
25 objects can be determined in a substantially continuous manner. In this embodiment of this invention, each emitter will radiate a different wave length or wave form or frequency pulse of radiation. Therefore, the radiation emitted from each emitter is simultaneously distinct from  
30 the radiation emitted from the other emitters. Under these conditions, the location of each emitter can be determined continuously by a set of sensors which is tuned to the specific, different radiation of each emitter. Therefore, the location of each emitter can be determined  
35 continuously, whereby the position and orientation of either or both of the objects can be calculated by the computer from these continuous locations of the different emitters.



While it is a significant distinction of this invention from the prior art that:

in the prior art:

5 the first object is intended to be moved and the second object is intended to be stationary; and **B**  
position and orientation of the first object is frequently determined, but the position and orientation of the second object is only determined at the start of the operation and at any time that the second object, the cranium, which  
10 is intended not to be moved at all during the operation, is known by the surgeon to be moved;

whereas

according to this invention:

15 the first object is intended to be moved, and the second object is not intended to be rigidly immobilized in place, or, put another way, the second object is permitted to move and is even expected to move; and

20 the position and the orientation of the first object is frequently determined, and the position and orientation of the second object is also frequently determined. The position and orientation of these two objects may be determined at the same frequency or at different frequencies (or even continuously) as desired by  
25 the operator.

In preferred embodiments of this invention, the position and orientation of the second object will be determined from one hundredth to ten times, most preferably from a quarter as often to four times, as often  
30 as the frequency at which the position and orientation of the first object is determined. As a general proposition, there is no limit on the relationship between these frequencies of measurement. The preferred relationships set forth herein are illustrative and not limiting. The  
35 frequency of each measurement is dependent on the amount of movement which is allowed and is intended to be shown on the CRT. The upper limit on this frequency is determined by the ability of the emitters to be

distinguished. There is no lower limit.

In the instant specification, the emitters have been described as being on the first and second objects and being movable therewith, and the sensors have been described as being in a fixed relation to the coordinate system. While this is the preferred system, it is by no means the only configuration of the system of this invention. It is also within the scope of this invention to provide the emitters in fixed relationship to the coordinate system, and the sensors on the first and second objects, respectively. The wiring may be somewhat more cumbersome in this configuration, but that should not detract from the viability of such a reversal.

This invention has been described with reference to a first and a second moving object, and the determination of each of their absolute and relative positions and orientations in a fixed coordinate system. It will be clear that this same system applies to more than two objects. In fact, the position and orientation of any number of objects can be determined, both absolutely with respect to the coordination system, and relatively with respect to each other, by the practice of this invention. Thus, when this specification and the claims appended hereto speak of a first and a second object, these can be two out of any number of total objects. This number is merely illustrative of the practice of this invention and is in no way limiting thereon.

Thus, the preferred system of this invention performs the three primary tasks of this invention, preferably, but not necessarily, simultaneously:

the absolute position and orientation of the second object, the cranium, in the fixed coordination system is determined at least very frequently;

the relationship between the absolute position and orientation of the second object with respect to the previously taken images of that object, particularly the inside structures of that object, is determined at least

very frequently; and

the absolute position and orientation of the first object, the probe, is determined at least very frequently. The accomplishment of these three tasks then permits the computer to accomplish the three essential secondary tasks of this invention:

5

to calculate the position and orientation of the first object, the probe, in relation to the second object, the cranium, even though the first object, or a portion of it, is out of the line of sight of either the surgeon or the sensors;

10

to select the appropriate slice of the previously taken model of the interior of the second object which corresponds to the present time position and orientation of the first object in relation to the present time position and orientation of the second object; and

15

to display the appropriate slice of the previously taken image of the second object with the present time position and orientation of the first object correctly depicted thereon.

20

Both the initial and the continual correlation determinations can be automatically initiated and updated by the computer 36 in some predetermined timed sequence or continuously. In fact, according to the most preferred aspect of this embodiment of this invention, the correlation phase is frequently, briefly from time to time, or even continuously, repeated, interspersed in between measurements in the operational phase or conducted simultaneously with the operational phase of the practice of this invention for the purpose of recalculating the linear transformations  $M$  and  $M'$  when the second object (such as a surgical patient) moves relative to the sensors.

25

30

During normal operation, the tip coordinates are transformed in a step 44 using the transformation computed in step 45. The new transformed coordinates, relative to the image coordinate system, are used to determine the plane of some two-dimensional cross-section through the

35

three-dimensional image model 41 accessible in the accessible memory 43. The simplest method is simply to choose the existing diagnostic image plane located closest to the probe tip's coordinates relative to the model coordinate system.

5  
In any case, a step 47 transforms the two-dimensional cross-sectional slice to a screen image and places a cursor on it to mark the location of the probe tip superimposed in the image. Scaling and viewing parameters determine how the image is displayed. Because the surgeon may not be able to simultaneously view the patient (object) and the computer display screen, the step 47 should be controlled by the surgeon, such as for example by placing an activating button on the probe.

10  
Pressing the button can be the signal for freezing the image and the depicted position and orientation of the probe tip marker at that instant on the display screen.

15  
In a more complex embodiment of this invention, the computer system could generate and display on the screen a cut-away view at an arbitrary angle, for example, perpendicular to the direction the probe is pointing, using the data from multiple image slices. In simpler cases, the computer simply displays any one or more convenient image slices through the location of the probe tip. For example, the displayed slice might simply be the original CT slice which includes the location of the probe tip, or is closest to that location. In any case, the computer then causes the image a cursor at the current position of the probe tip to be displayed on this previously taken image of a slice through the second object.

20  
25  
30

35  
An alternative means, to record the location of the reference points in the coordinate space of the imaging apparatus during the imaging phase, employs an additional, separate instance of the three-dimensional position mensuration probe, sensors, control unit, and computer of the present invention. In order to implement this embodiment of this invention, the additional sensors

are permanently attached directly on the imaging apparatus. The additional probe measures the location of the reference points at the time of imaging, and the additional control unit and computer determines and records their locations relative to the coordinate system of the imaging apparatus. The advantage of this approach is that the fiducial markers, that is the landmarks or reference pins, need not be within the limited cross-sectional slices visible to the imaging device.

As an alternative to true three-dimensional images, standard x-ray radiographs from several distinct directions can be used to construct a crude model in lieu of the imaging phase described above. Radiographs from two or more directions are digitally scanned, and four non-coplanar reference points on them are identified with a cursor or light pen. In a correlation phase similar to that described above, these four points on the patient are digitized just prior to surgery. Then, during surgery, the location of the probe tip is projected onto the digitized computer images of the two-dimensional radiographs where the projection is uniquely defined by mapping and transferring the reference point coordinates from the model coordinate system to the fixed sensor coordinate system.

In a further embodiment of this invention, a videotape recording of the computer screen (as well as the direct view of the surgeon and patient) is used to help document the performance of the instant procedure. Radiation emitters may be present on more than one standard surgical tool such as the microscope, scalpel, forceps, and cauterizer, each of which thereby becomes, in effect, a probe. These emitters should be differentiated from each other in the same manner as aforesaid.

The method and apparatus of the optical mensuration and correlation apparatus 10 of the present invention has been completely described. While some of the numerous modifications and equivalents of the system of this invention have been described herein, still other

modifications and changes will readily occur to those of ordinary skill in the art. For instance, the preferred embodiment described herein uses visible light, since human operators can readily observe if the light sources are operative or whether they are causing troublesome reflections. Clearly, other wavelengths of electromagnetic radiation could be used without departing from the spirit and scope of the invention. Non-visible light, such as infrared or ultra-violet light, would have the advantage of not distracting the surgeon with flashing lights. Ultra-sound could be used conveniently. Other modifications to the detector "optics" and lenses are possible which would change, and possibly improve, the image characteristics on the detectors. For example, toroidal lenses could be used which are longitudinally curved along an arc with a radius equal to the focal length of the lens. Similarly, the surfaces of the photodetectors could also be curved, thus allowing the images of distant light sources to remain in sharp focus, regardless of their positions. Numerous enhancements of the digital data are possible by suitably programming the computer.

The most preferred aspects of this invention use electromagnetic radiation, and especially visible light, as the radiation from the emitters. This use of light for this function is a major improvement over the use in the prior art of audible sound emitters and detectors. However, prior art systems which are based on the use of sound emitters can be reprogrammed to carry out the operations to substantially continuously recorrelate the position and orientation of the second object during the surgical procedure, as they have been described herein. Thus, the movement of the second object can be at least frequently, if not continuously, tracked using sound emitters and detectors and suitable temperature compensation techniques. In this last regard, the aforementioned ability of the instant system to determine and transmit the temperature of the probe tip can be used

to good advantage when using sound as the radiation of choice. The fact that the use of electromagnetic radiation, particularly light, emitters and sensors is an improvement over the use of audible sound emitters and sensors is not intended to be a limitation of the practice of continuously or frequently following the movement of the first or the second objects. That is an invention in and of itself using any emitter-sensor pair.

It should be understood, however, that the transmission between emitters and sensors operate differently, and measure different things when electromagnetic radiation is used as compared to the use of sound, audible or ultrasonic. In the case of electromagnetic radiation, what is being measured is the angle that the radiation path makes between the emitter and the sensor relative to some arbitrary fixed line. By measuring all of these angles of the rays between the emitters and the sensors, conventional analytic geometry solutions will locate the points in space where the various emitters are. On the other hand, when sound radiation is used, what is being measured is the distance between each of the emitters and the sensors. Again, conventional analytic geometry solutions will precisely locate the point in space which is occupied by each emitters/sensor. While the casual observer, or the operator of the systems of this invention will not observe any difference in result, there is a marked difference in the way that result is achieved, and therefore this will necessitate a difference in the manner in which this system is programmed.

The foregoing is illustrative of the principles of the invention. Since numerous modifications and changes will readily occur to those of ordinary skill in the art, given the teachings of this specification, this invention is not limited to the exact construction and operation shown and described herein. Accordingly, all suitable modifications and equivalents that may be resorted to in light of disclosure of this specification

are considered to fall within the scope of the invention as defined by the following claims.



## WHAT IS CLAIMED IS:

- 1           1. A system for determining the present time  
2 location and orientation of a moveable first object with  
3 respect to a moveable second object and for graphically  
4 indicating the corresponding position and orientation of  
5 said first object on a previously taken image of said  
6 second object, which comprises:  
7           a present time three-dimensional fixed coordinate  
8 system;  
9           at least three radiation sensor means in fixed  
10 spacial relationship to said present time three-  
11 dimensional fixed coordinate system which is spaced from  
12 said movable objects;  
13           said moveable first and second objects located within  
14 said fixed coordinate system;  
15           a three-dimensional local coordinate system, which  
16 remains fixed with respect to said second object, but is  
17 movable, along with said second object, within said fixed  
18 coordinate system;  
19           at least three non-collinear radiation emitter means  
20 in fixed spacial relationship to said second object and at  
21 known coordinates in said local coordinate system;  
22           previously taken three-dimensional image data which  
23 geometrically describe said second object;  
24           at least two spaced apart radiation emitter means  
25 disposed on said first object;  
26           first movement means to move said first object  
27 relative to said second object and to said fixed  
28 coordinate system;  
29           second movement means to move said second object  
30 relative to said first object and to said fixed coordinate  
31 system;  
32           means to transmit radiation between said radiation  
33 emitter means on said first and second objects and said  
34 radiation sensor means in fixed relation to said fixed  
35 coordination system;

36 means to distinguish between radiation emitted from  
37 any one radiation emitter means from radiation emitted  
38 from all of the other radiation emitter means;

39 means to independently determine the location of each  
40 of said radiation emitter means on said first object as a  
41 function of said radiation being transferred between at  
42 least two of said radiation emitter means on said first  
43 object and said radiation sensor means in fixed relation  
44 to said fixed coordination system;

45 means to determine the position and orientation of  
46 any point on said first object in relation to said fixed  
47 coordinate system by integrating the determined location  
48 of at least two of said radiation emitter means on said  
49 first object;

50 means to independently determine the location of each  
51 of said radiation emitter means associated with said  
52 second object as a function of said radiation being  
53 transferred between said radiation emitter means  
54 associated with said second object and said radiation  
55 sensor mean in fixed relation to said fixed coordination  
56 system;

57 means to determine the position and orientation of  
58 said second object in said fixed coordinate system by  
59 integrating the determined location of said radiation  
60 emitter means associated with said second object;

61 means to determine the position and orientation of  
62 said second object in said local coordinate system;

63 means to orient said previously taken three  
64 dimensional image data of said second object in said local  
65 coordination system such as to match the present time  
66 position and orientation of said second object with the  
67 previously taken said image data;

68 means to integrate the present time determined  
69 position and orientation of said second object with the  
70 present time determined position and orientation of said  
71 first object in the same fixed coordinate system whereby  
72 integrating the present time determined position and  
73 orientation of said first object in relation to said

74 previously taken three dimensional image data;

75 means to, in present time, repeatedly determine the  
76 position and orientation of said first object with  
77 sufficient frequency to enable displaying the movement of  
78 said first object in relation to said second object; and

79 means to, in present time, repeatedly determine the  
80 position and orientation of said second object with  
81 sufficient frequency to enable correlating a moved  
82 position and orientation of said second object with a view  
83 of said previously taken three dimensional image data  
84 which is consistent with the moved position and  
85 orientation of said second object and allows for the  
86 correct present time positioning of an image corresponding  
87 to the present time position and orientation of said first  
88 object in relation to said previously taken image data;

89 wherein, as a consequence of said repeated  
90 determinations and integrations of the positions and  
91 orientations of said first and second objects, and  
92 correlation of said position and orientation of said  
93 second object with said previously taken three dimensional  
94 image data, an image representative of said first object  
95 is correctly positioned in present time on said previously  
96 taken image data regardless of the movement of said first  
97 and/or second objects in relation to said fixed coordinate  
98 system.

1 2. A system as claimed in claim 1 wherein said  
2 first and second objects intersect, which system further  
3 comprises means to display so much of said previously  
4 taken three dimensional image data as corresponds to the  
5 intersecting location of said first and second objects,  
6 and means to display said representation of said first  
7 object on said image display in its correct present time  
8 position.

1 3. A system as claimed in claim 1 wherein said  
2 frequency of determining the position and orientation of  
3 said second object is about 0.01 to 100 times the

4 frequency of determining the position and orientation of  
5 said first object.

1 4. A system as claimed in claim 1 wherein the  
2 position and orientation of said second object, the  
3 integration of the position and orientation of said second  
4 object and said image data, and the position and  
5 orientation of said first object are all determined  
6 substantially continuously.

1 5. The system as claimed in claim 1 wherein  
2 said previously taken three dimensional image data  
3 comprise a succession of substantially two dimensional  
4 slices at previously determined, known locations and  
5 orientations through said second object.

1 6. The system as claimed in claim 1 wherein  
2 said radiation emitter means are disposed on said first  
3 and second objects and said sensor means are spaced from  
4 said first and second objects and are disposed in fixed  
5 relationship to said fixed coordinate system.

1 7. The system as claimed in claim 1 wherein  
2 said sensor means are disposed on said first and second  
3 objects and said emitter means are spaced from said first  
4 and second objects and are disposed in fixed relationship  
5 to said fixed coordinate system.

1 8. The system as claimed in claim 1 wherein  
2 said radiation is electromagnetic radiation.

1 9. The system as claimed in claim 8 wherein  
2 said radiation is light.

1 10. The system as claimed in claim 9 wherein  
2 light of different wave lengths is emitted from each  
3 different emitter means.

1           11. The system as claimed in claim 8 wherein  
2 said radiation is pulse radiated from different of said  
3 emitter means sequentially in a repeating order.

1           12. The system as claimed in claim 1 wherein  
2 said radiation is sound.

1           13. The system as claimed in claim 1 wherein  
2 said radiation emitter means and said sensor means  
3 comprise means for detecting linear and rotational  
4 inertial motion.

1           14. The system as claimed in claim 1 wherein  
2 said previously taken image data are taken by a means  
3 which is not suitable for use during a surgical procedure.

1           15. The system as claimed in claim 1 wherein  
2 said first object is a surgical probe and said second  
3 object is a surgical patient, wherein said surgical probe  
4 is adapted to be partially inserted into said patient such  
5 that said inserted portion is not visible to an inserter  
6 thereof.

1           16. The system as claimed in claim 15 wherein  
2 at least two emitter means are disposed on so much of said  
3 first object as is not inserted into said patient, and  
4 wherein said so disposed emitter means on said first  
5 object are a known distance from a tip of said probe which  
6 is adapted for insertion into said patient.

1           17. The system as claimed in claim 1 wherein  
2 said image data are selected from the group consisting of  
3 magnetic resonant image data, computed tomography data,  
4 ultra sound data, or X-radiation data.

1           18. The system as claimed in claim 1 wherein  
2 said second object is a patient, and said first object is  
3 an operating microscope, and wherein said image data are

4       projected onto the field of said operating microscope.

1               19. The system as claimed in claim 1 wherein  
2       said second object is a part of the anatomy of a human.

1               20. The system as claimed in claim 19 wherein  
2       the part of the anatomy is a head.

1               21. The system as claimed in claim 19 wherein  
2       there are reference points on said second object, which  
3       are distinguishing anatomical features, which are in fixed  
4       spacial relationship to said emitter means associated with  
5       said second object.

1               22. The system as claimed in claim 1 operated  
2       intermittently, but sufficiently frequently to depict the  
3       relative movement of said first object relative to said  
4       second object, and the movement of said second object  
5       relative to said fixed coordinate system.

1               23. The system as claimed in claim 2 including  
2       means for monitoring in present time the movement of said  
3       first object in true relation to said previously taken  
4       three dimensional image data.

1               24. The system as claimed in claim 1 including  
2       means for selecting the slice of said previously taken  
3       image data which corresponds to the present time location  
4       of said first object such that a representation of said  
5       first object is correctly disposed on said image slice in  
6       present time.

1               25. The system as claimed in claim 1 including  
2       means to freeze a display of a previously taken image and  
3       a representation of said first object for a finite period  
4       of time.

1               26. The system as claimed in claim 1 including

2 means to continuously display a series of slices of said  
3 previously taken three dimensional data which correspond  
4 to a changing position of said first object relative to  
5 said second object, and which correctly reflect movement  
6 of said second object relative to said fixed coordinate  
7 system in present time.

1 27. A system for determining the present time  
2 location and orientation of a moveable first object with  
3 respect to a second object and for graphically indicating  
4 the corresponding position and orientation of said first  
5 object on a previously taken image of said second object,  
6 which comprises:

7 a present time three-dimensional fixed coordinate  
8 system;

9 at least three radiation sensor means in fixed  
10 spacial relationship to said present time three-  
11 dimensional fixed coordinate system which are spaced from  
12 said objects;

13 said first and second objects located within said  
14 fixed coordinate system;

15 at least three non-collinear fiducial markers in  
16 fixed spacial relationship to said second object and at  
17 known coordinates in said local coordinate system;

18 a three dimensional local coordinate system which is  
19 fixed in relation to said second object;

20 previously taken three-dimensional image data which  
21 geometrically describe said second object including said  
22 fiducial markers;

23 at least two spaced apart electromagnetic radiation  
24 emitter means disposed on said first object;

25 first movement means to move said first object  
26 relative to said second object and to said fixed  
27 coordinate system;

28 means to transmit radiation between said radiation  
29 emitter means on said first object and said radiation  
30 sensor means in fixed relation to said fixed coordination  
31 system;

32 means to distinguish radiation emitted from any one  
33 radiation emitter means from radiation emitted from all of  
34 the other radiation emitter means;

35 means to independently determine the location of each  
36 of said radiation emitter means on said first object as a  
37 function of said radiation being transferred between at  
38 least two of said radiation emitter means on said first  
39 object and said radiation sensor means in fixed relation  
40 to said fixed coordination system;

41 means to determine the position and orientation of  
42 any point on said first object in relation to said fixed  
43 coordinate system by integrating the determined location  
44 of at least two of said radiation emitter means on said  
45 first object;

46 means to independently determine the location of each  
47 of said fiducial markers on said second object in said  
48 fixed coordinate system;

49 means to determine the position and orientation of  
50 said second object in said fixed coordinate system by  
51 integrating the determined location of said fiducial  
52 markers on said second object;

53 means to orient said previously taken three  
54 dimensional image data of said second object such as to  
55 match the present time position and orientation of said  
56 second object with the previously taken said image data;

57 means to integrate the present time determined  
58 position and orientation of said second object with the  
59 present time determined position and orientation of said  
60 first object in the same fixed coordinate system whereby  
61 integrating the present time determined position and  
62 orientation of said first object in relation to said  
63 previously taken three dimensional image data; and

64 means to, in present time, repeatedly determine the  
65 positions and orientations of said first object with  
66 sufficient frequency to enable displaying the movement of  
67 said first object in relation to said second object;

68 wherein, as a consequence of said repeated  
69 determinations and integrations of the positions and



70 orientations of said first object, and correlation of said  
71 positions and orientations of said second object with said  
72 previously taken three dimensional image data, an image  
73 representative of said first object is correctly  
74 positioned in present time on said previously taken image  
75 data regardless of the movement of said first object in  
76 relation to said fixed coordinate system.

1 28. A system as claimed in claim 27 wherein  
2 said first and second objects intersect, which system  
3 further comprises means to display so much of said  
4 previously taken three dimensional image data as  
5 corresponds to the intersecting location of said first and  
6 second objects, and means to display said representation  
7 of said first object on said image display in its correct  
8 present time position.

1 29. A system as claimed in claim 27 wherein  
2 the integration of the position and orientation of said  
3 second object and said image data, the position and  
4 orientation of said first object, and the correlation of  
5 the position and orientation of said first object with  
6 said image data are all determined substantially  
7 continuously.

1 30. The system as claimed in claim 27 wherein  
2 said previously taken three dimensional image data  
3 comprise a succession of substantially two dimensional  
4 slices through said second object.

1 31. The system as claimed in claim 27 wherein  
2 said radiation emitter means are disposed on said first  
3 object and said sensor means are spaced from said first  
4 and second objects and are disposed in fixed relationship  
5 to said fixed coordinate system.

1 32. The system as claimed in claim 27 wherein  
2 said sensor means are disposed on said first object and

3 said radiation emitter means are spaced from said first  
4 object and are disposed in fixed relationship to said  
5 fixed coordinate system.

1 33. The system as claimed in claim 27 wherein  
2 said radiation is light.

1 34. The system as claimed in claim 33 wherein  
2 said radiation is visible light.

1 35. The system as claimed in claim 33 wherein  
2 light of different wave lengths is emitted from each  
3 different emitter means.

1 36. The system as claimed in claim 33 wherein  
2 said light is pulse radiated from different of said  
3 radiation emitter means sequentially in a repeating order.

1 37. The system as claimed in claim 27 wherein  
2 said radiation emitter means and said sensor means  
3 comprise means for detecting linear and rotational  
4 inertial motion.

1 38. The system as claimed in claim 27 wherein  
2 said previously taken image data are taken by a means  
3 which is not suitable for use during a surgical procedure.

1 39. The system as claimed in claim 27 wherein  
2 said first object is a surgical probe and said second  
3 object is a surgical patient, wherein said surgical probe  
4 is adapted to be partially inserted into said patient such  
5 that said inserted portion is not visible to an inserter  
6 thereof.

1 40. The system as claimed in claim 39 wherein  
2 at least two emitter means are disposed on so much of said  
3 first object as is not inserted into said patient, and  
4 wherein said so disposed emitter means on said first

5 object are a known distance from a tip of said probe which  
6 is adapted for insertion into said patient.

1 41. The system as claimed in claim 27 wherein  
2 said image data are selected from the group consisting of  
3 magnetic resonant image data, computed tomography data,  
4 ultra sound data, or X-radiation data.

1 42. The system as claimed in claim 27 wherein  
2 said second object is a patient, and said first object is  
3 an operating microscope, and wherein said image data are  
4 projected onto the field of said operating microscope.

1 43. The system as claimed in claim 27 wherein  
2 said second object is a part of the anatomy of a human.

1 44. The system as claimed in claim 43 wherein  
2 the part of the anatomy is a head.

1 45. The system as claimed in claim 43 wherein  
2 there are reference points on said second object, which  
3 are distinguishing anatomical features, which are in fixed  
4 spacial relationship to said second object.

1 46. The system as claimed in claim 27 operated  
2 intermittently, but sufficiently frequently to depict the  
3 relative movement of said first object relative to said  
4 second object.

1 47. The system as claimed in claim 28 including  
2 means for monitoring in present time the movement of said  
3 first object in true relation to said previously taken  
4 three dimensional image data.

1 48. The system as claimed in claim 27 including  
2 means for selecting the slice of said previously taken  
3 image data which corresponds to the present time location  
4 of said first object such that a representation of said

5 first object is correctly disposed on said image slice in  
6 present time.

1 49. The system as claimed in claim 27 including  
2 means to freeze a display of a previously taken image and  
3 a representation of said first object for a finite period  
4 of time.

1 50. The system as claimed in claim 27 including  
2 means to continuously display a series of slices of said  
3 previously taken three dimensional data which correspond  
4 to a changing position of said first object relative to  
5 said second object, and which correctly reflect the  
6 position and orientation of said second object relative to  
7 said fixed coordinate system in present time.

1 51. In a system for determining the present  
2 time location and orientation of a moveable first object  
3 with respect to a second object and for graphically  
4 indicating the corresponding position and orientation of  
5 said first object on a previously taken image of said  
6 second object, which comprises:

7 a present time three-dimensional fixed coordinate  
8 system;

9 at least three radiation sensor means, in fixed  
10 spacial relationship to said present time three-  
11 dimensional fixed coordinate system, which are spaced from  
12 said objects;

13 said first and second objects located within said  
14 fixed coordinate system;

15 a three dimensional local coordinate system which is  
16 fixed in relation to said second object;

17 at least three non-collinear fiducial markers in  
18 fixed spacial relationship to said second object and at  
19 known coordinates in said local coordinate system;

20 previously taken three-dimensional image data which  
21 geometrically describe said second object including said  
22 fiducial markers in said fixed coordinate system;

23 at least two spaced apart radiation emitter means  
24 disposed on said first object;

25 first movement means to move said first object  
26 relative to said second object;

27 means to transmit radiation between said radiation  
28 emitter means on said first object and said radiation  
29 sensor means in fixed relation to said fixed coordinate  
30 system;

31 means to distinguish radiation emitted from any one  
32 radiation emitter means from radiation emitted from all of  
33 the other radiation emitter means;

34 means to independently determine the location of each  
35 of said radiation emitter means on said first object as a  
36 function of said radiation being transferred between at  
37 least two of said radiation emitter means on said first  
38 object and said radiation sensor means in fixed relation  
39 to said fixed coordinate system;

40 means to determine the position and orientation of  
41 any point on said first object in relation to said fixed  
42 coordinate system by integrating the determined location  
43 of at least two of said radiation emitter means on said  
44 first object;

45 means to independently determine the location of each  
46 of said fiducial markers on said second object;

47 means to determine the position and orientation of  
48 said second object in said fixed coordinate system by  
49 integrating the determined location of said fiducial  
50 markers on said second object into said fixed coordinate  
51 system;

52 means to orient said previously taken three  
53 dimensional image data of said second object such as to  
54 match the present time position and orientation of said  
55 second object with the previously taken said image data;

56 means to integrate the present time determined  
57 position and orientation of said second object with the  
58 present time determined position and orientation of said  
59 first object in the same fixed coordinate system whereby  
60 integrating the present time determined position and

61 orientation of said first object in relation to said  
62 previously taken three dimensional image data; and

63 means to, in present time, repeatedly determine the  
64 position and orientation of said first object with  
65 sufficient frequency to enable displaying the movement of  
66 said first object in relation to said second object;

67 wherein, as a consequence of said repeated  
68 determinations and integrations of the positions and  
69 orientations of said first object, and correlation of said  
70 position and orientation of said second object with said  
71 previously taken three dimensional image data, an image  
72 representative of said first object is correctly  
73 positioned in present time on said previously taken image  
74 data regardless of the movement of said first object in  
75 relation to said fixed coordinate system;

76 the improvement which comprises said radiation  
77 being electromagnetic radiation.

1 52. In a system for determining the present  
2 time location and orientation of a moveable first object  
3 with respect to a moveable second object and for  
4 graphically indicating the corresponding position and  
5 orientation of said first object on a previously taken  
6 image of said second object, which comprises:

7 a present time three-dimensional fixed coordinate  
8 system;

9 at least three radiation sensor means in fixed  
10 spacial relationship to said present time three-  
11 dimensional fixed coordinate system which is spaced from  
12 said movable objects;

13 said moveable first and second objects located within  
14 said fixed coordinate system;

15 a three-dimensional local coordinate system, which  
16 remains fixed with respect to said second object, but is  
17 movable, along with said second object, within said fixed  
18 coordinate system;

19 at least three non-collinear fiducial marker means in  
20 fixed spacial relationship to said second object and at

21 known coordinates in said local coordinate system;  
22 previously taken three-dimensional image data which  
23 geometrically describe said second object;  
24 at least two spaced apart radiation emitter means  
25 disposed on said first object;  
26 first movement means to move said first object  
27 relative to said second object and to said fixed  
28 coordinate system;  
29 second movement means to move said second object  
30 relative to said first object and to said fixed coordinate  
31 system;  
32 means to transmit radiation between said radiation  
33 emitter means on said first object and said radiation  
34 sensor means in fixed relation to said fixed coordination  
35 system;  
36 means to distinguish radiation emitted from any one  
37 radiation emitter means from radiation emitted from all of  
38 the other radiation emitter means;  
39 means to independently determine the location of each  
40 of said radiation emitter means on said first object as a  
41 function of said radiation being transferred between at  
42 least two of said radiation emitter means on said first  
43 object and said radiation sensor means in fixed relation  
44 to said fixed coordination system;  
45 means to determine the position and orientation of  
46 any point on said first object in relation to said fixed  
47 coordinate system by integrating the determined location  
48 of at least two of said radiation emitter means on said  
49 first object; and  
50 in present time, repeatedly determining the position  
51 and orientation of said first object with sufficient  
52 frequency to enable displaying the movement of said first  
53 object in relation to said second object;  
54 the improvement which comprises:  
55 radiation emitter means associated in fixed, known  
56 spacial relationship to said fiducial markers;  
57 means to determine the location of said fiducial  
58 markers on said second object as a function of said

59 radiation being transferred between said radiation emitter  
60 means associated with said second object and said  
61 radiation sensor means in fixed relation to said fixed  
62 coordinate system;

63 means to determine the position and orientation of  
64 said second object in said fixed coordinate system by  
65 integrating the determined location of said radiation  
66 emitter means associated with said second object;

67 means to determine the position and orientation of  
68 said second object in said local coordinate system;

69 means to orient said previously taken three  
70 dimensional image data of said second object in said local  
71 coordination system such as to match the present time  
72 position and orientation of said second object with the  
73 previously taken said image data;

74 means to integrate the present time determined  
75 position and orientation of said second object with the  
76 present time determined position and orientation of said  
77 first object in the same fixed coordinate system whereby  
78 integrating the present time determined position and  
79 orientation of said first object in relation to said  
80 previously taken three dimensional image data; and

81 means to, in present time, repeatedly determine the  
82 position and orientation of said second object with  
83 sufficient frequency to enable correlating a moved  
84 position and orientation of said second object with a view  
85 of said previously taken three dimensional image data  
86 which is consistent with the moved position and  
87 orientation of said second object and allows for the  
88 correct present time positioning of an image corresponding  
89 to the present time position and orientation of said first  
90 object in relation to said previously taken image data.

1 53. A method of determining the present time  
2 location and orientation of a moveable first object with  
3 respect to a moveable second object and for graphically  
4 indicating the corresponding position and orientation of  
5 said first object on a previously taken image of said



6 second object, which comprises:  
7 defining a present time three-dimensional global  
8 fixed coordinate system;  
9 providing at least three radiation sensor means in  
10 fixed spacial relationship to said present time three-  
11 dimensional fixed coordinate system which is spaced from  
12 said movable objects;  
13 disposing said moveable first and second objects  
14 located within said fixed coordinate system;  
15 defining a three-dimensional local coordinate system,  
16 which remains fixed with respect to said second object,  
17 but is movable, along with said second object, within said  
18 fixed coordinate system;  
19 providing at least three non-collinear radiation  
20 emitter means in fixed spacial relationship to said second  
21 object and at known coordinates in said local coordinate  
22 system;  
23 taking, at a previous time, three-dimensional image  
24 data which geometrically describe said second object;  
25 providing at least two spaced apart radiation emitter  
26 means disposed on said first object;  
27 providing first movement means to move said first  
28 object relative to said second object and to said fixed  
29 coordinate system;  
30 providing second movement means to move said second  
31 object relative to said first object and to said fixed  
32 coordinate system;  
33 transmitting radiation between said radiation emitter  
34 means on said first and second objects and said radiation  
35 sensor means in fixed relation to said fixed coordination  
36 system;  
37 distinguishing radiation emitted from any one  
38 radiation emitter means from radiation emitted from all of  
39 the other radiation emitter means;  
40 independently determining the location of each of  
41 said radiation emitter means on said first object as a  
42 function of said radiation being transferred between at  
43 least two of said radiation emitter means on said first

44 object and said radiation sensor means in fixed relation  
45 to said fixed coordination system;

46 determining the position and orientation of any point  
47 on said first object in relation to said fixed coordinate  
48 system by integrating the determined location of at least  
49 two of said radiation emitter means on said first object;

50 independently determining the location of each of  
51 said radiation emitter means associated with said second  
52 object as a function of said radiation being transferred  
53 between said radiation emitter means associated with said  
54 second object and said radiation sensor means in fixed  
55 relation to said fixed coordination system;

56 determining the position and orientation of said  
57 second object in said fixed coordinate system by  
58 integrating the determined location of said radiation  
59 emitter means associated with said second object;

60 determining the position and orientation of said  
61 second object in said local coordinate system;

62 orienting said previously taken three dimensional  
63 image data of said second object in said local  
64 coordination system such as to match the present time  
65 position and orientation of said second object with the  
66 previously taken said image data;

67 integrating the present time determined position and  
68 orientation of said second object with the present time  
69 determined position and orientation of said first object  
70 in the same fixed coordinate system whereby integrating  
71 the present time determined position and orientation of  
72 said first object in relation to said previously taken  
73 three dimensional image data;

74 in present time, repeatedly determining the position  
75 and orientation of said first object with sufficient  
76 frequency to enable displaying the movement of said first  
77 object in relation to said second object; and

78 in present time, repeatedly determining the position  
79 and orientation of said second object with sufficient  
80 frequency to enable correlating a moved position and  
81 orientation of said second object with a view of said

82 previously taken three dimensional image data which is  
83 consistent with the moved position and orientation of said  
84 second object and allows for the correct present time  
85 positioning of an image corresponding to the present time  
86 position and orientation of said first object in relation  
87 to said previously taken image data;

88 wherein, as a consequence of said repeatedly  
89 determining and integrating the positions and orientations  
90 of said first and second objects, and correlating said  
91 position and orientation of said second object with said  
92 previously taken three dimensional image data, positioning  
93 an image representative first object correctly in present  
94 time on said previously taken image data regardless of the  
95 movement of said first and/or second objects in relation  
96 to said fixed coordinate system.

1 54. A method as claimed in claim 53 wherein  
2 said first and second objects intersect, which method  
3 further comprises displaying so much of said previously  
4 taken three dimensional image data as corresponds to the  
5 intersecting location of said first and second objects,  
6 and displaying said representation of said first object on  
7 said image display in its correct present time position.

1 55. A method as claimed in claim 53 wherein  
2 including determining the position and orientation of said  
3 second object at a frequency which is about 0.01 to 100  
4 times the frequency of determining the position and  
5 orientation of said first object.

1 56. A method as claimed in claim 53 including  
2 substantially continuously determining the position and  
3 orientation of said second object, the integration of the  
4 position and orientation of said second object and said  
5 image data, and the position and orientation of said first  
6 object.

1 57. The method as claimed in claim 53 including

2 taking three dimensional image data which comprise a  
3 succession of substantially two dimensional slices at a  
4 previous time at known locations and orientations through  
5 said second object.

1 58. The method as claimed in claim 53 including  
2 disposing said radiation emitter means on said first and  
3 second objects, spacing said sensor means a distance from  
4 said first and second objects, and disposing said sensor  
5 means in fixed relationship to said fixed coordinate  
6 system.

1 59. The method as claimed in claim 53 including  
2 disposing said sensor means on said first and second  
3 objects, spacing said emitter means a distance from said  
4 first and second objects, and disposing said radiation  
5 emitters in fixed relationship to said fixed coordinate  
6 system.

1 60. The method as claimed in claim 53 wherein  
2 said radiation is electromagnetic radiation

1 61. The method as claimed in claim 60 wherein  
2 said radiation is light.

1 62. The method as claimed in claim 61 including  
2 emitting light of different wave lengths from each  
3 different emitter means.

1 63. The method as claimed in claim 60 including  
2 pulse radiating said radiation from different of said  
3 emitter means sequentially in a repeating order.

1 64. The method as claimed in claim 53 wherein  
2 said radiation is sound.

1 65. The method as claimed in claim 53 including  
2 detecting linear and rotational inertial motion through

3 said radiation emitter means and said sensor means.

1 66. The method as claimed in claim 53 including  
2 taking said previously taken image data by a means which  
3 is not suitable for use during a surgical procedure.

1 67. The method as claimed in claim 53 wherein  
2 said first object is a surgical probe and said second  
3 object is a surgical patient, and partially inserting said  
4 surgical probe within said patient such that said inserted  
5 portion is not visible to an inserter thereof.

1 68. The method as claimed in claim 67 including  
2 disposing at least two emitter means on so much of said  
3 first object as is not inserted into said patient, and  
4 disposing said exposed portion of said emitter means on  
5 said first object a known distance from a tip of said  
6 probe which is adapted for insertion into said patient.

1 69. The method as claimed in claim 53 including  
2 selecting said image data from the group consisting of  
3 magnetic resonant image data, computed tomography data,  
4 ultra sound data, or X-radiation data.

1 70. The method as claimed in claim 53 wherein  
2 said second object is a patient, and said first object is  
3 an operating microscope, and including projecting said  
4 image data onto the field of an operating microscope.

1 71. The method as claimed in claim 53 wherein  
2 said second object is a part of the anatomy of a human.

1 72. The method as claimed in claim 71 wherein  
2 the part of the anatomy is a head.

1 73. The system as claimed in claim 71 wherein  
2 there are fiducial reference points on said second object,  
3 which are distinguishing anatomical features, which are in

4 fixed spacial relationship to said emitter means  
5 associated with said second object.

1 74. The method as claimed in claim 53 which is  
2 operated intermittently, but sufficiently frequently to  
3 depict the relative movement of said first object relative  
4 to said second object, and the movement of said second  
5 object relative to said fixed coordinate system.

1 75. The method as claimed in claim 54 including  
2 monitoring, in present time, the movement of said first  
3 object in true relation to said previously taken three  
4 dimensional image data.

1 76. The method as claimed in claim 53 including  
2 selecting the slice of said previously taken image data  
3 which corresponds to the present time location of said  
4 first object, and correctly positioning a representation  
5 of said first object on said selected image slice in  
6 present time.

1 77. The method as claimed in claim 53 including  
2 freezing a display of a previously taken image and a  
3 representation of said first object thereon for a finite  
4 period of time.

1 78. The method as claimed in claim 53 including  
2 continuously displaying a series of slices of said  
3 previously taken three dimensional data which correspond  
4 to a changing position of said first object relative to  
5 said second object, and correctly reflecting thereon the  
6 movement of said second object relative to said fixed  
7 coordinate system in present time.

Fig. 1A

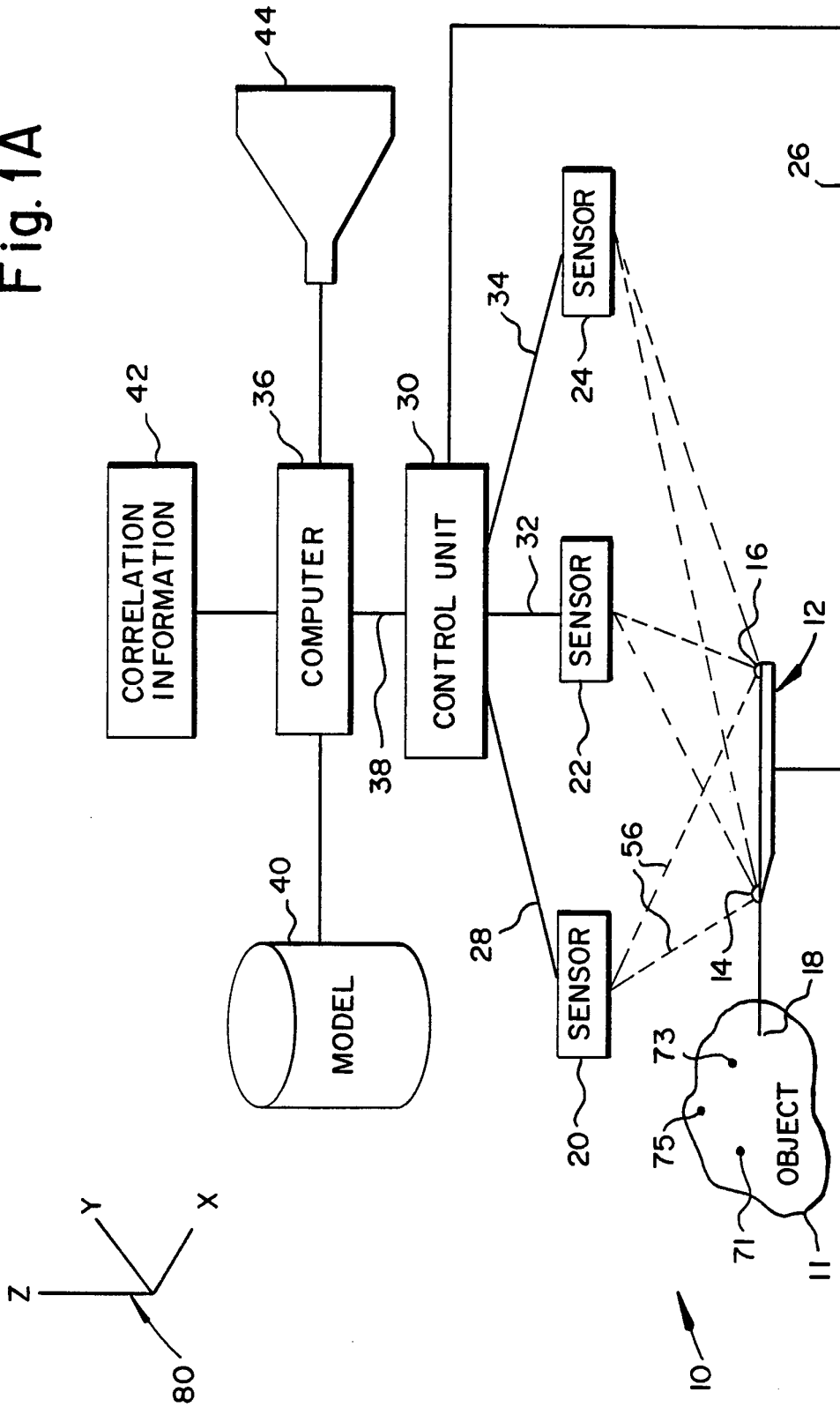
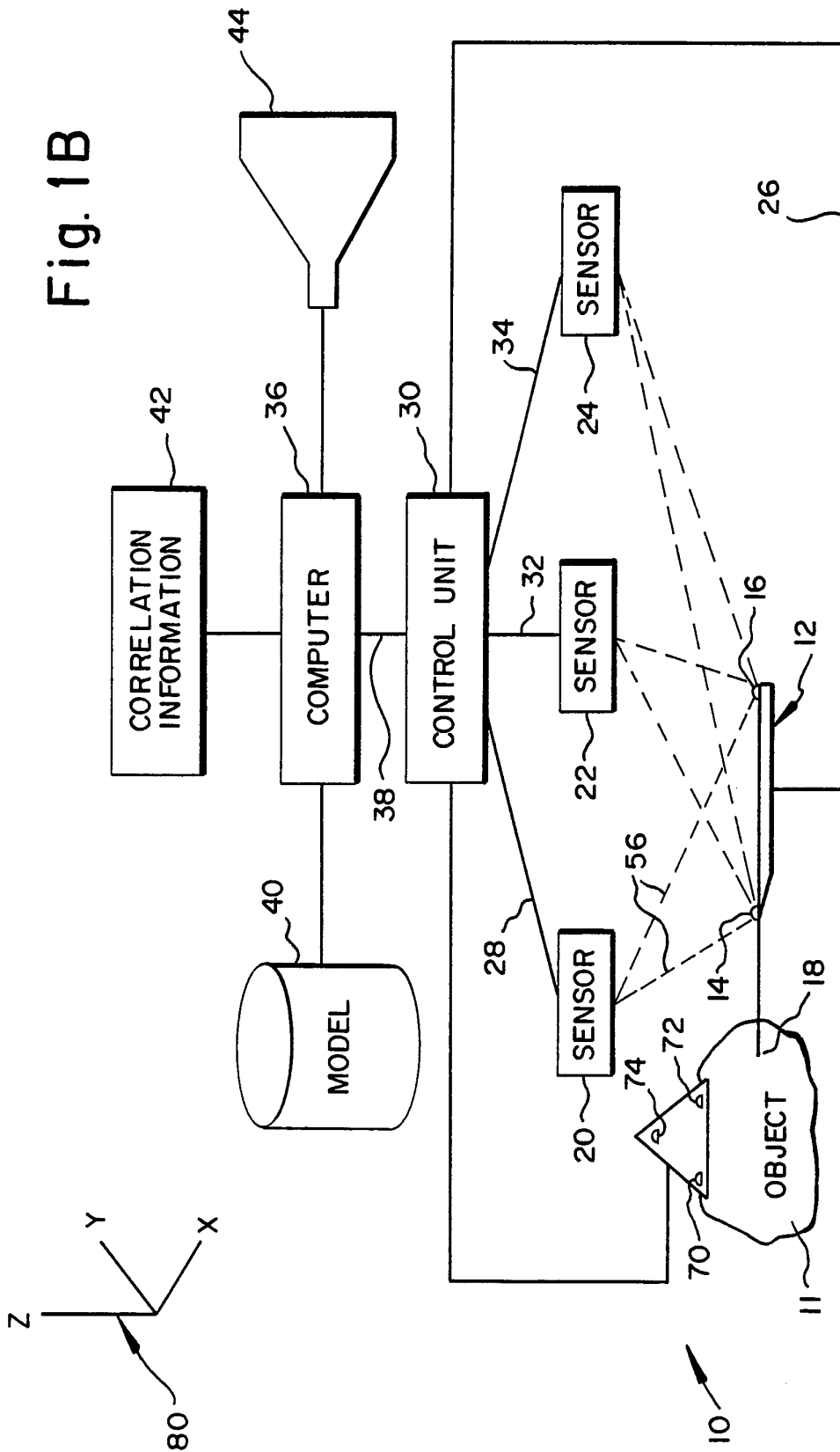

Fig. 1B





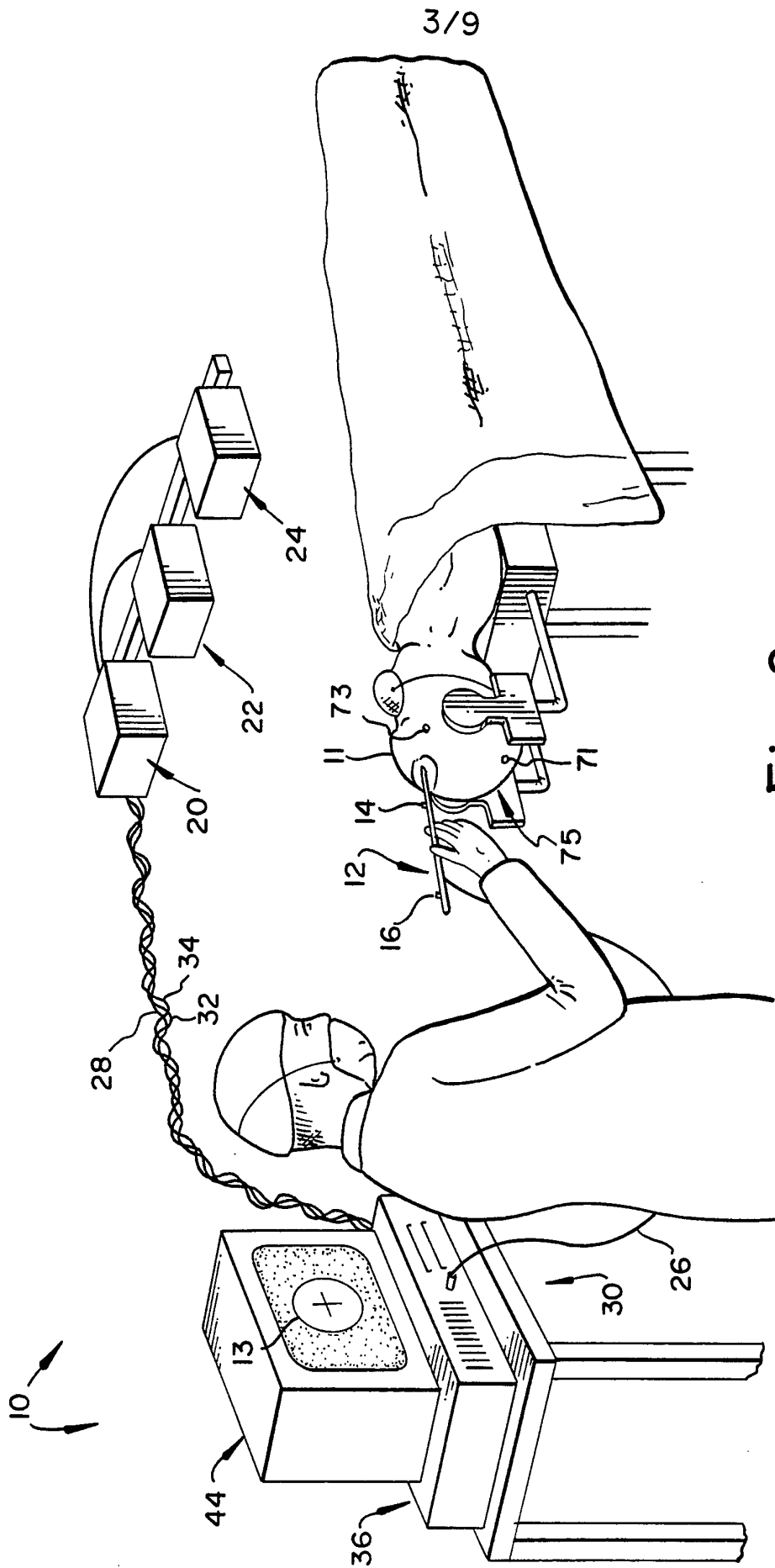

Fig. 2

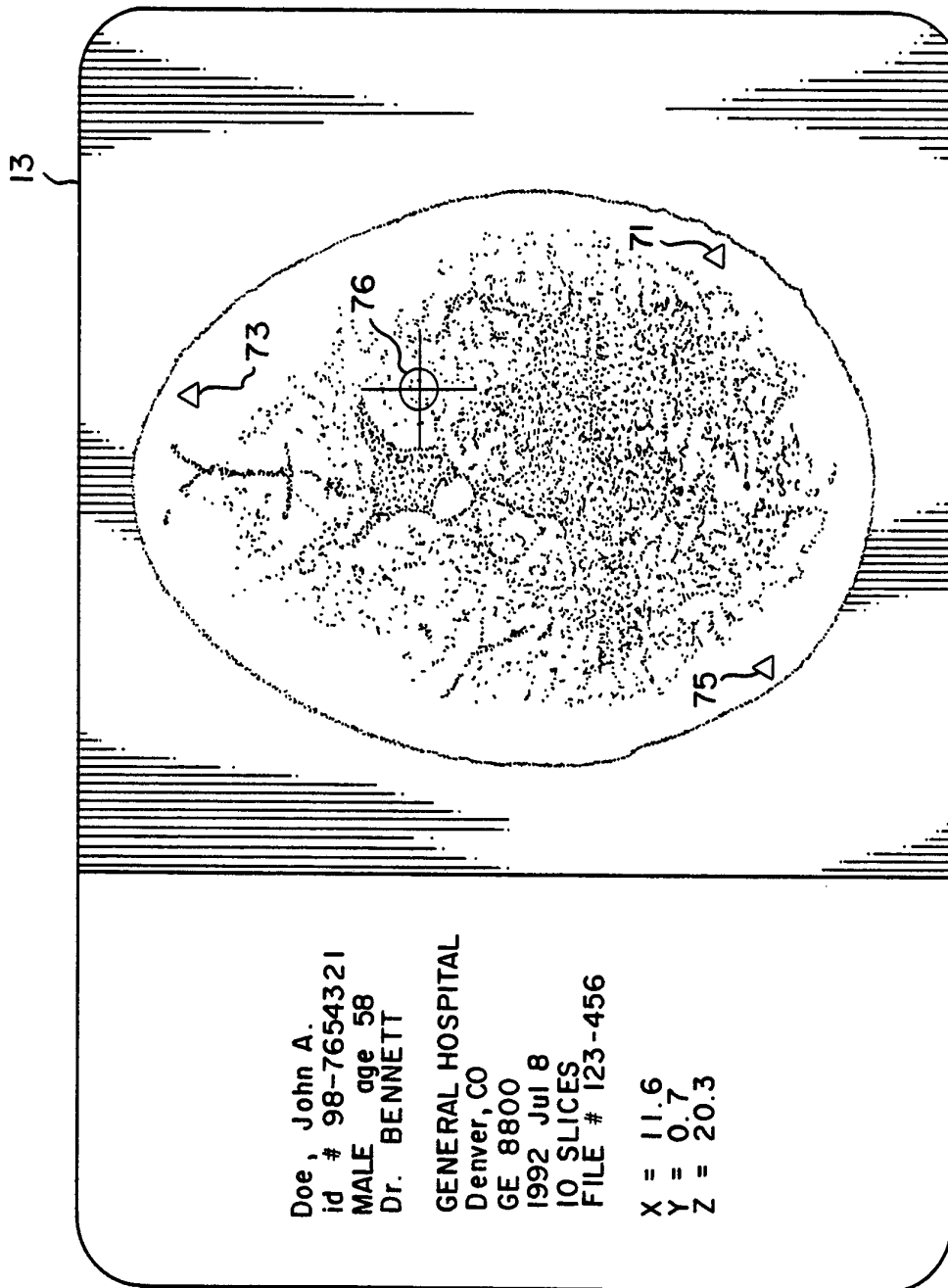

Fig. 3

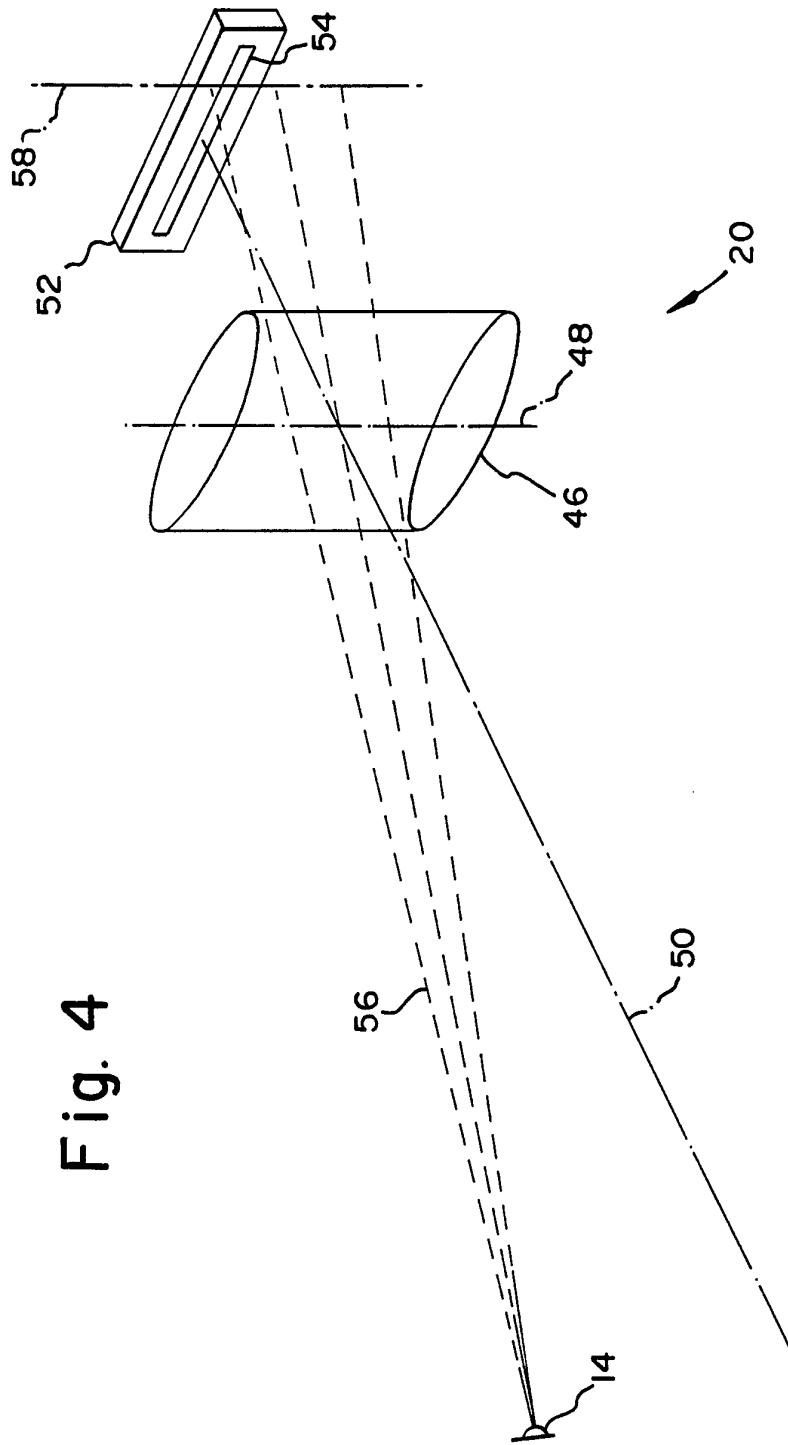

Fig. 4

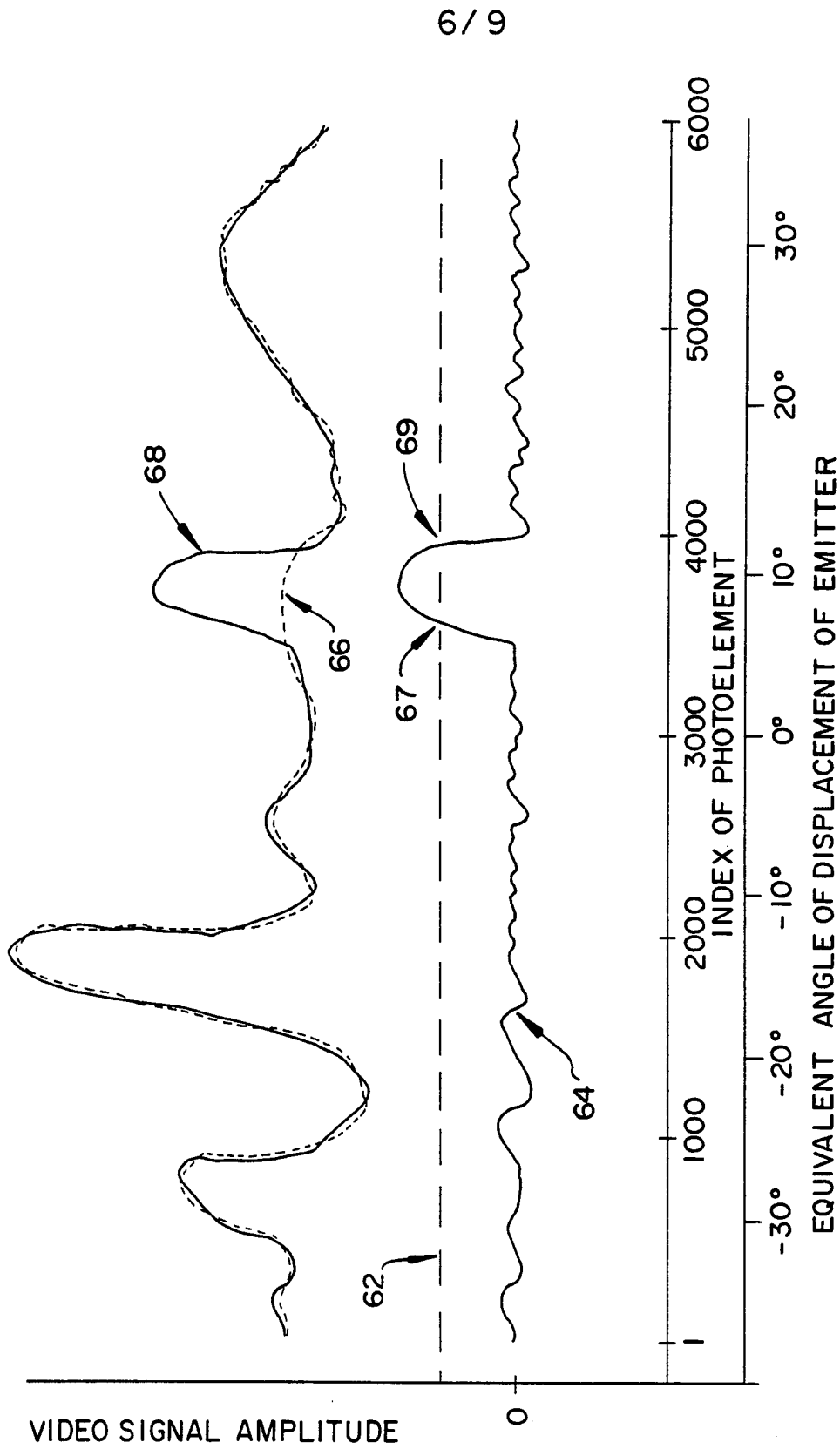

Fig. 5

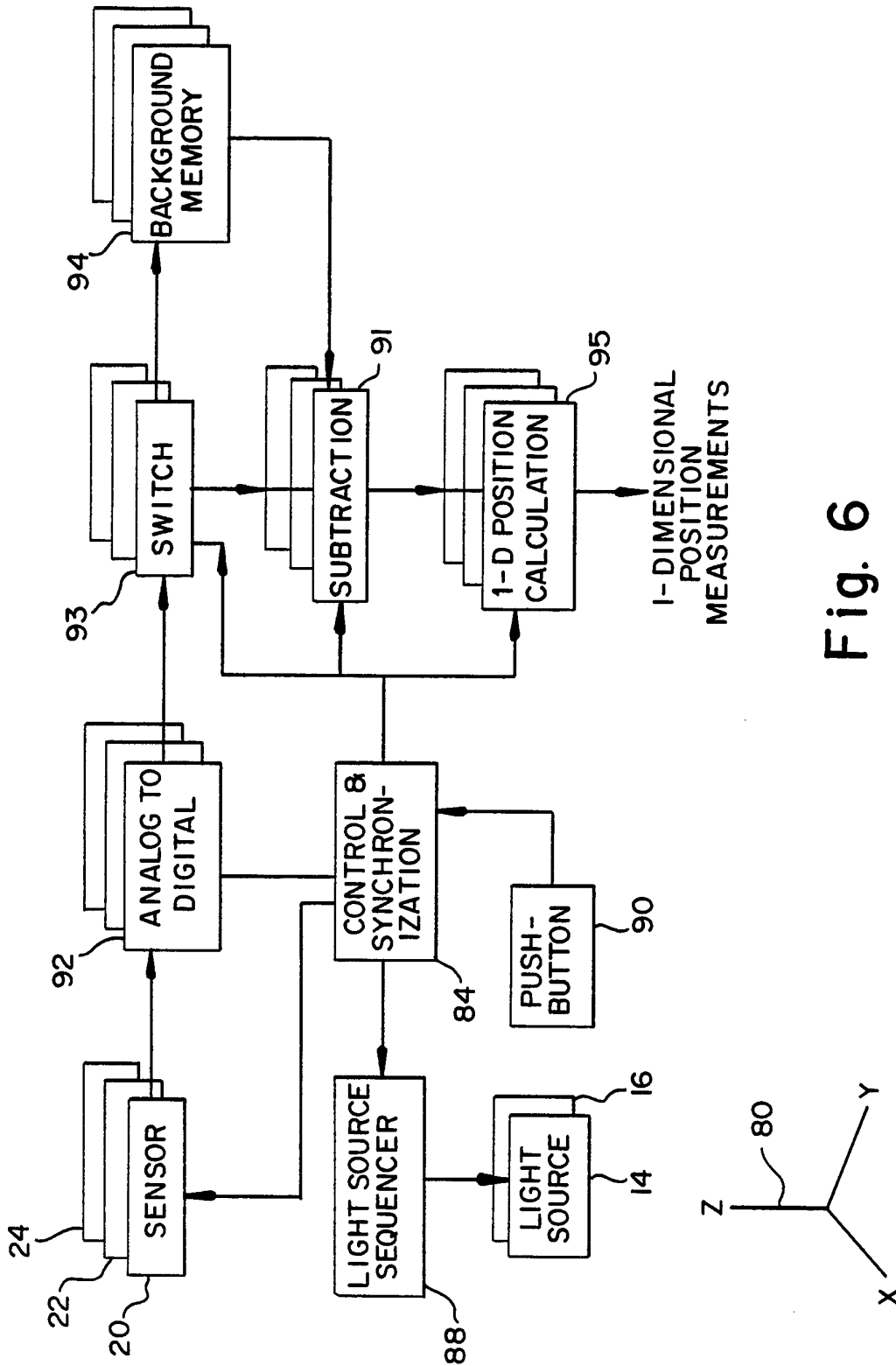

Fig. 6

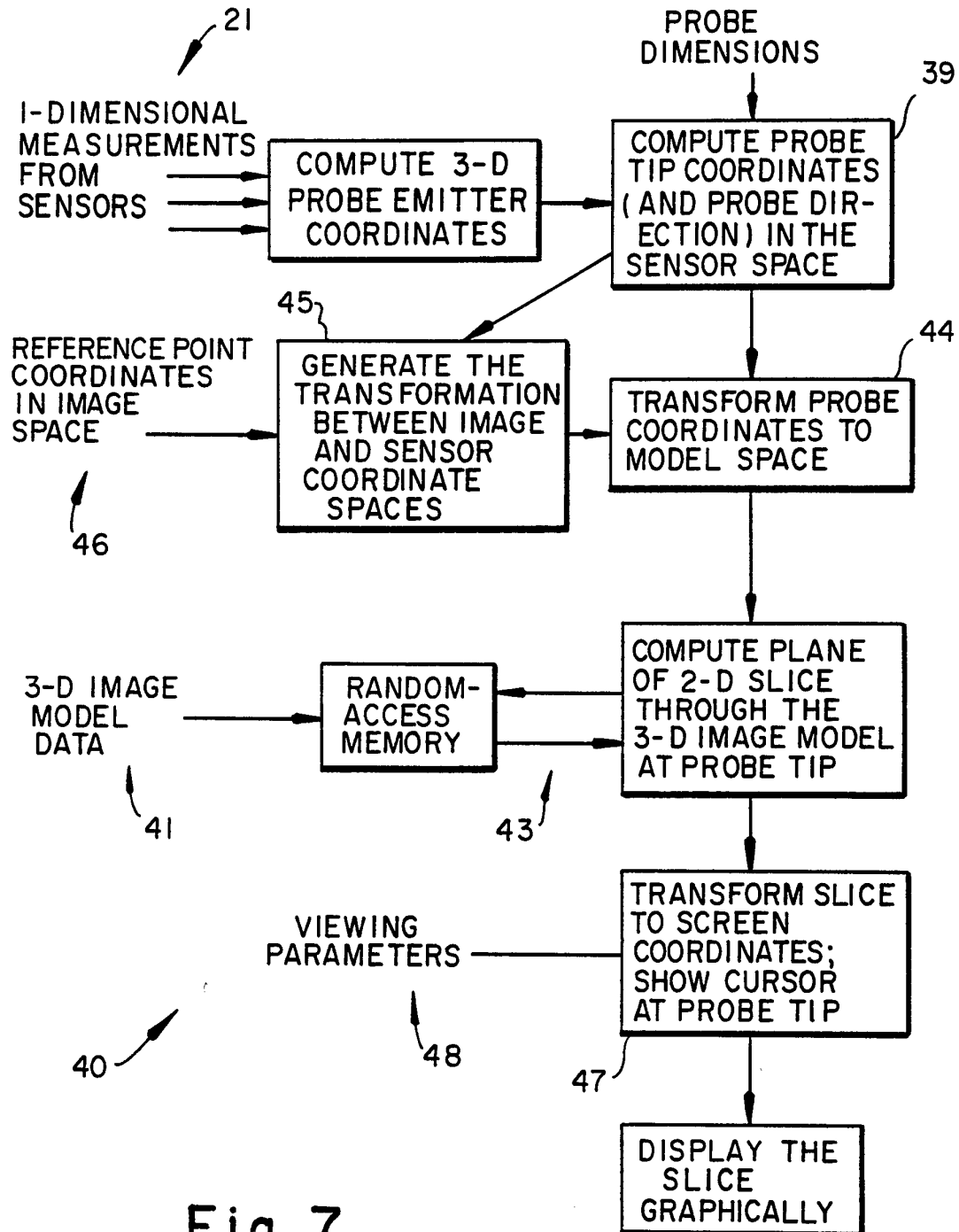

Fig. 7

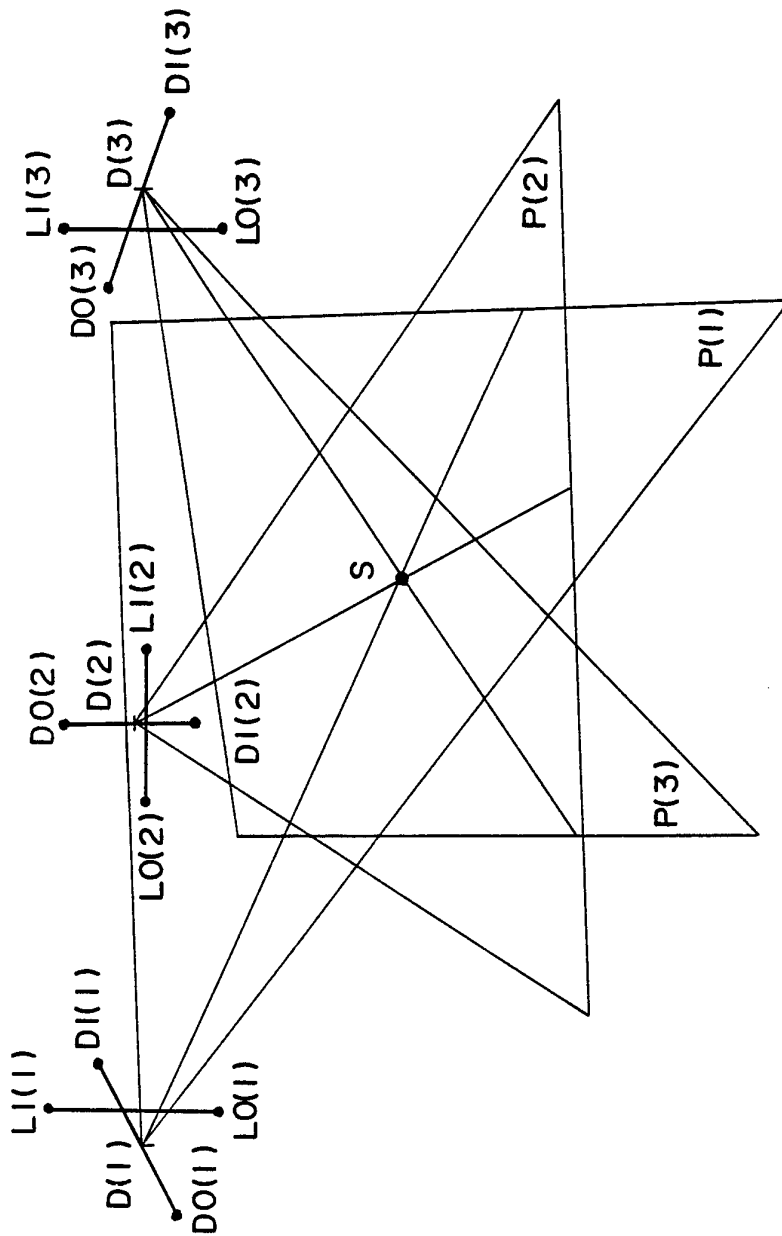

Fig. 8

INTERNATIONAL SEARCH REPORT

International application No.  
PCT/US94/04298

**A. CLASSIFICATION OF SUBJECT MATTER**  
IPC(5) :A61B 5/05; G01B 11/00  
US CL :128/653.1; 356/376  
According to International Patent Classification (IPC) or to both national classification and IPC

**B. FIELDS SEARCHED**  
Minimum documentation searched (classification system followed by classification symbols)  
U.S. : Please See Extra Sheet.

Documentation searched other than minimum documentation to the extent that such documents are included in the fields searched  
NONE

Electronic data base consulted during the international search (name of data base and, where practicable, search terms used)  
NONE

**C. DOCUMENTS CONSIDERED TO BE RELEVANT**

Category*	Citation of document, with indication, where appropriate, of the relevant passages	Relevant to claim No.
X --- Y	SACDAC User's Guide, Version 2e, 1989 March 2. 3-D coordinate acquisition software for the SAC GP8-3D digitizer and the IBM Personal Computer, See the entire PixSys document.	1-8, 11-32, 37-51, 53-60, 63-78 ----- 9, 10, 33-36, 53-62
X ---, E Y	US, A, 5,309,913, (KORMOS ET AL.), 10 May 1994. See entire document.	1-8, 11-32, 37-52, 63-78 ----- 9, 10, 33-36, 53-62
Y, P	US, A, 5,273,039, (FUJIWARA ET AL.), 28 December 1993, See entire document.	18, 42, 70

Further documents are listed in the continuation of Box C.  See patent family annex.

* Special categories of cited documents:	"T" later document published after the international filing date or priority date and not in conflict with the application but cited to understand the principle or theory underlying the invention
"A" document defining the general state of the art which is not considered to be of particular relevance	"X" document of particular relevance; the claimed invention cannot be considered novel or cannot be considered to involve an inventive step when the document is taken alone
"E" earlier document published on or after the international filing date	"Y" document of particular relevance; the claimed invention cannot be considered to involve an inventive step when the document is combined with one or more other such documents, such combination being obvious to a person skilled in the art
"L" document which may throw doubts on priority claim(s) or which is cited to establish the publication date of another citation or other special reason (as specified)	"&" document member of the same patent family
"O" document referring to an oral disclosure, use, exhibition or other means	
"P" document published prior to the international filing date but later than the priority date claimed	

Date of the actual completion of the international search 18 AUGUST 1994	Date of mailing of the international search report 21 SEP. 1994
---	--

Name and mailing address of the ISA/US Commissioner of Patents and Trademarks Box PCT Washington, D.C. 20231 Facsimile No. (703) 305-3230	Authorized officer <i>Andie Robinson</i> SAMUEL GILBERT Telephone No. (703) 305-3553
---	---



## INTERNATIONAL SEARCH REPORT

International application No.  
PCT/US94/04298

C (Continuation). DOCUMENTS CONSIDERED TO BE RELEVANT		
Category*	Citation of document, with indication, where appropriate, of the relevant passages	Relevant to claim No.
Y	US, A, 4,722,056, (ROBERTS ET AL.), 26 January 1988. See entire document.	1-78
A	US, A, 4,896,673, (ROSE ET AL.), 30 January 1990, See entire document.	1-78
A	US, A, 4,793,355, (CRUM ET AL.), 27 December 1988. See entire document.	1-78

**INTERNATIONAL SEARCH REPORT**

International application No.

PCT/US94/04298

**B. FIELDS SEARCHED**

Minimum documentation searched

Classification System: U.S.

128/653.01, 653.02, 653.05; 250/203.1, 206.1, 206.2, 561; 340/870.11, 853.1, 853.2; 356/141, 152, 372, 373, 375, 376; 364/413.01, 413.22; 606/130