



(86) Date de dépôt PCT/PCT Filing Date: 2005/10/24
 (87) Date publication PCT/PCT Publication Date: 2006/05/04
 (85) Entrée phase nationale/National Entry: 2007/04/23
 (86) N° demande PCT/PCT Application No.: US 2005/038382
 (87) N° publication PCT/PCT Publication No.: 2006/047520
 (30) Priorité/Priority: 2004/10/25 (US60/621,816)

(51) Cl.Int./Int.Cl. *A61F 2/06* (2006.01)
 (71) Demandeur/Applicant:
ALVEOLUS, INC., US
 (72) Inventeurs/Inventors:
SATASIYA, PANKAJ, US;
ALEXANDER, TONY, US
 (74) Agent: RIDOUT & MAYBEE LLP

(54) Titre : DISPOSITIF DE REPOSITIONNEMENT ET DE RETRAIT D'UNE ENDOPROTHESE VASCULAIRE ET
METHODE ASSOCIEE

(54) Title: STENT REMOVAL AND REPOSITIONING DEVICE AND ASSOCIATED METHOD

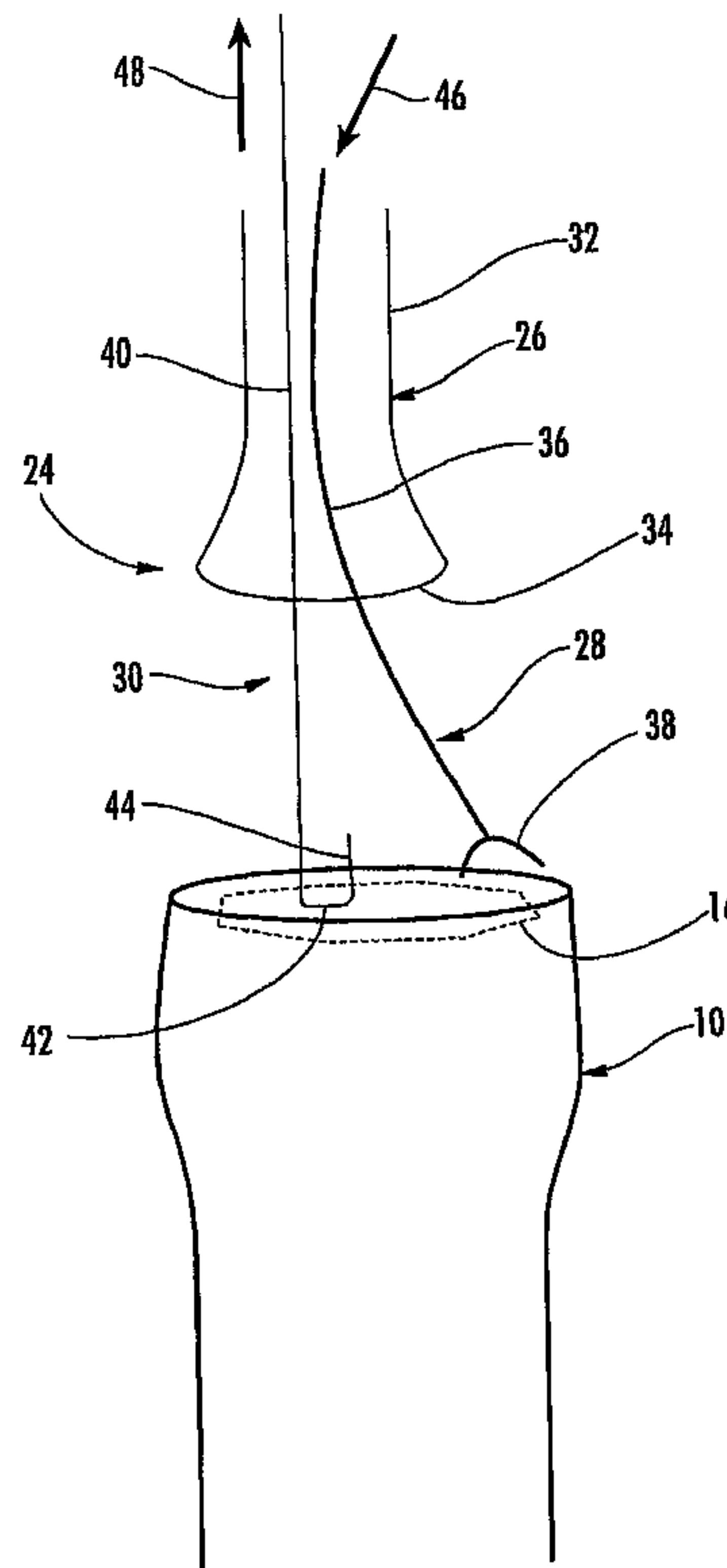

(57) **Abrégé/Abstract:**

A stent removal device (24) for removing or repositioning a stent (10) from within a lumen is provided. The stent (10) typically comprises at least one suture (16) arranged circumferentially about the stent (10). The stent removal device includes a tube (26) positioned within the lumen proximate to the stent (10), wherein the tube (26) is capable of receiving at least a portion of the stent (10). The stent removal device (24) also includes a pusher (28) positioned within the tube (26) and capable of engaging the stent (10) or the suture (16). The stent removal device (24) further includes a hook (30) positioned within the tube (26) and capable of engaging the suture (16) such that force applied to the hook (30) causes the stent (10) to purse string.

WO 2006/047520 A3

ZW), Eurasian (AM, AZ, BY, KG, KZ, MD, RU, TJ, TM),
European (AT, BE, BG, CH, CY, CZ, DE, DK, EE, ES, FI,
FR, GB, GR, HU, IE, IS, IT, LT, LU, LV, MC, NL, PL, PT,
RO, SE, SI, SK, TR), OAPI (BF, BJ, CF, CG, CI, CM, GA,
GN, GQ, GW, ML, MR, NE, SN, TD, TG).

Published:

- *with international search report*
- *before the expiration of the time limit for amending the claims and to be republished in the event of receipt of amendments*

(88) Date of publication of the international search report:
24 August 2006

For two-letter codes and other abbreviations, refer to the "Guidance Notes on Codes and Abbreviations" appearing at the beginning of each regular issue of the PCT Gazette.

STENT REMOVAL AND REPOSITIONING DEVICE AND ASSOCIATED METHOD

BACKGROUND OF THE INVENTION

1) Field of the Invention

The present invention relates to a stent device and, in particular, to a stent removal and repositioning device that is capable of removing a stent from a lumen
5 or repositioning the stent within the lumen.

2) Description of Related Art

Stents are devices that are inserted into body lumens such as vessels or passages to keep the lumen open and prevent closure due to a stricture, external
10 compression, or internal obstruction. In particular, stents are commonly used to keep blood vessels open in the coronary arteries, and they are frequently inserted into the ureters to maintain drainage from the kidneys, the bile duct for pancreatic cancer or cholangiocarcinoma, or the esophagus for strictures or cancer. Vascular
as well as nonvascular stenting has evolved significantly; unfortunately, there
15 remain significant limitations with respect to the technology for positioning and removing stents following implantation into various portions of a patient's anatomy.

In various areas of application, *e.g.*, bronchus, biliary, trachea, or esophagus, the stents must be removable from the body or repositionable as a
20 function of the course of the disease or treatment. This can be problematic since newly formed tissue can grow on the support frame of the stent and even grow through it, which can result in complications when removing a stent. In this regard, stents have been developed that include a support frame surrounded on the outside by a thread or wire. The support frame can be radially constricted by
25 pulling on the thread ends that are each provided with a loop or the like, creating a "purse-string" effect, which makes it possible for the frame to be removed.

However, when the wire or thread is guided or braided in multiple windings around the support frame, a high degree of friction results between the two stent components, which has a disadvantageous effect on the explantation process. In addition, stents having eyelets for looping the thread therethrough may have sharp
5 edges that cause the thread to tear or break during the removal process.

Alternatively, surgeons have grasped the stent with forceps or a similar instrument to reposition or remove the stent from within the lumen. However, this can be complex at times. For instance, grasping the stent risks damage to the stent and/or the surrounding tissue, *e.g.*, during removal of a tracheal stent with grasping
10 forceps, the vocal chords may be damaged if the stent is in its deployed state with an expanded diameter. Also, grasping may lead to damage to the stent itself, as the forceps may have difficulty accessing or adequately gripping the stent to remove or reposition it.

Thus, there is a need in the industry for a stent removal device that reduces
15 the risk of damage to the stent, thread or suture, and the surrounding tissue. In addition, there is a need for a stent removal device that is capable of easily accessing the stent, as well as effectively constricting the stent and thereafter repositioning and/or removing the stent from a lumen.

20 BRIEF DESCRIPTION OF THE SEVERAL VIEWS OF THE DRAWINGS

Having thus described the invention in general terms, reference will now be made to the accompanying drawings, which are not necessarily drawn to scale, and wherein:

FIG. 1a is a plan view of a stent having an interstice geometry, according to
25 one embodiment of the present invention;

FIG. 1b is an enlarged view of a portion of the stent shown in FIG. 1a, further illustrating the interstice geometry;

FIG. 2 is an end view of the stent shown in FIG. 1a, depicting a suture arranged circumferentially about the stent, according to one embodiment of the
30 present invention;

FIG. 3 is an enlarged view of a portion of the stent as seen in FIG. 1a and illustrating the suture arranged throughout interstices of the stent;

FIG. 4 is an enlarged view of a portion of a stent having a suture arranged thereabout, according to an additional embodiment of the present invention;

FIG. 5 is an enlarged view of a stent illustrating a suture arranged throughout the interstices of the stent according the invention;

5 FIG. 6 is a greatly enlarged view of a threaded suture arranged about a stent according to the invention;

FIG. 7 is a perspective view illustrating a stent removal device, according to one embodiment of the present invention;

10 FIG. 7a depicts enlarged views of various configuration of a gripping member capable of being employed with the stent removal device shown in FIG. 7;

FIG. 8 is a perspective view illustrating a stent removal device, according to an additional embodiment of the present invention; and

15 FIGS. 9a-d illustrate a series of perspective views demonstrating a sequence of steps to remove or reposition a stent with the stent removal device of FIG. 7.

DETAILED DESCRIPTION OF THE INVENTION

The present invention now will be described more fully hereinafter with reference to the accompanying drawings, in which some, but not all embodiments
20 of the invention are shown. Indeed, this invention may be embodied in many different forms and should not be construed as limited to the embodiments set forth herein; rather, these embodiments are provided so that this disclosure will satisfy applicable legal requirements. Like numbers refer to like elements throughout.

With reference to FIGS. 1-3, a stent **10** is shown having interstice
25 geometry. The stent **10** includes a scaffolding of struts, as well as a suture **16** intertwined about the struts. The struts generally include a plurality of interconnected legs **12** and connectors **14**. As shown in FIG. 1a, the stent **10** includes a series of legs **12** arranged circumferentially about the stent, as well as arranged in a series of rows along the longitudinal axis of the stent, while a
30 plurality of connectors **14** are arranged parallel to the longitudinal axis of the stent to connect the rows together. The suture **16** is preferably located proximate to each of the proximal and distal ends of the stent **10**, as shown in FIG. 1a. FIG. 1b

demonstrates that there is a cover **18** layer extending between the legs **12** and connectors **16**.

The legs **12** and connectors **14** of the stent **10** are preferably formed from a composite material such as Ni, C, Co, Cu, Cr, H, Fe, Nb, O, Ti and combinations thereof (*e.g.*, Nitinol). The composite material is generally formed into a compressed tube from which the stent is etched and is formed on a suitable shaping device to give the stent the desired external geometry. The stent **10** is formed of a memory metal that facilitates flexibility of the stent **10** such that the stent may be deformed and return to its original shape.

The stent **10** is generally cylindrical, having openings at the proximal and distal ends. As illustrated in FIG. 1a, the diameter of the proximal and distal ends is slightly larger than the diameter of longitudinal portion of the stent extending therebetween. In the event the stent **10** is to be shaped to the dimensions of a particular lumen, optical photography and/or optical videography of the target lumen may be conducted prior to stent formation. The interstice geometry of the stent **10** then can be etched and formed in accordance with the requirements of that target lumen. For example, if the stent **10** were designed for the trachea, which has a substantially D shaped lumen and additionally the middle portion of the stent is preferably softer than the proximal or distal ends, the stent could be designed to those specifications. In particular, if the topography of the trachea of a particular patient is captured optically and the appropriate dimension provided, a patient specific prosthesis could be engineered. These techniques can be adapted to other non-vascular lumina but is very well suited for vascular applications where patient specific topography is a function of a variety of factors such as genetics, lifestyle, *etc.*

It should be pointed out that, unlike the use of differing shape memory materials to change regions of a stent **10**, stents in accordance with the present invention can take on an infinite number of characteristic combinations of interstice geometry by changing angles, segment lengths, and segment thicknesses during the etching and forming stages of stent engineering or during post formation processing and polishing steps. Moreover, by modifying the geometry of the connectors **14**, additional functionality may be achieved.

The cover 18 is typically a polymer, such as polyurethanes (*e.g.*, polycarbonate urethane, or Chronoflex® manufactured by Cardiotech International), that is applied between the legs 12 and connectors 14 to provide a predetermined shape for the stent 10, as well as graft each of the legs and
5 connectors into a unitary structure. The cover 18 typically does not inhibit flexing or radial expansion of the stent 10. However, it is possible to make the cover 18 affect the flexing and radial expansion of the stent 10. The cover 18 typically forms a thin film when deposited on the stent 10.

As shown in FIGS. 5-6, the interstices are raised above the surface of the
10 cover 18. Thus, the cover 18 is preferably applied to the interior of the stent 10 such that the stent scaffolding is raised above the surface of cover (*e.g.*, 1 Å to 10⁶ Å). Providing a raised scaffolding above the surface of the cover 18 promotes cilia action by allowing cilia movement between stent 10 struts. However, as shown in FIG. 1b, the cover 18 may be applied to the exterior of the stent 10 scaffolding, or
15 may even be on applied on both sides of the scaffolding.

FIG. 1b also illustrates a scale 19 extending outwardly from the outer surface of the stent 10. The scale 19 is generally one or more legs 12 that protrude in a manner that act to prevent migration of the stent 10 when implanted into the lumen. For example, the scale 19 depicted in FIG. 1b would prevent migration of
20 the stent 10 in a downward direction. The scales 19 may extend from the outer surface in any number of orientations, and the scales typically 19 define an acute angle between the protruding leg(s) and the outer surface of the stent 10, although various angles may be incorporated in additional embodiments of the present invention. The scales 19 may extend from the outer surface of the stent 10 in any
25 desired location and as shown in FIG. 1, for example, the scales are located in the third or fourth row of legs 12. FIG. 1 also demonstrates that there may be several scales 19, although there may be any number of scales depending on the amount of anti-migration desired.

FIG. 3 illustrates that when the cover 18 is applied to the interior of the
30 stent 10 scaffolding, the cover may fold back over on itself at the proximal and/or distal ends of the stent. The cover 18 in FIG. 3 is shown as folding back over a first row of legs 12 circumferentially about the stent 10, although the cover could fold back various amounts, such as along the ends 10 of the legs proximate to the

proximal and/or distal ends of the stent, along several rows of legs and/or connectors 14, or not at all. Folding the cover 18 ensures that the proximal and distal ends of the stent 10 are smooth. In addition, folding the cover 18 prevents the ends 20 of the legs 12 from interlocking with one another during manufacturing or manipulation of the stent 10. For instance, the stent 10 shown in FIG. 3 includes T-shaped ends 20 that could potentially interlock with legs 12 and/or connectors 14 when the stent is folded or compressed.

The suture 16 may be any suitable suture material, as known to those skilled in the art, such as polypropylene. However, it is understood that the term “suture” as used herein could be any suitable thread or wire, as known to those skilled in the art, capable of enduring the forces applied during repositioning or removal of the stent 10 in alternative embodiments of the present invention.

Any number of configurations of stents 10 could be incorporated and still be within the present scope of the invention. An exemplary embodiment of the interstice geometry of a stent 10 and methods of manufacturing the stent is disclosed in U.S. Patent Publication No. 20040127973 (Application No. 10/674,972), entitled “Removable Biliary Stent,” which is assigned to the present assignee and is incorporated herein by reference. Thus, the interstice geometry of the stent 10 should not be limited to that depicted in the disclosed Figures, as any number of configurations of interstice geometry could be employed with the present invention to achieve various degrees of rigidity and functionality. U.S. Patent Publication No. 20040122511 (Application No. 10/669,450) entitled “Coated Stent with Geometry Determined Functionality and Method of Making the Same,” which is assigned to the present assignee, is also incorporated herein by reference, and further describes the cover 18 that may be employed with the present invention, including the types of materials and properties suitable for the cover, as well as the process of manufacturing the stent 10.

As depicted in FIG. 3, the suture 16 typically extends through the cover 18, along a series of legs 12, and then exits out of the cover. The intertwining of the suture 16 through the cover 18 and along the legs 12 continues about the entire circumference of the stent 10 until the ends of the suture are joined together such as with a knot 23, as shown in FIG. 2. The suture 16 in FIG. 2 is shown as being loosely arranged about the circumference of the stent 10 for illustrative purposes

only, as the suture will typically be in more intimate contact with the stent. However, the suture **16** typically provides a minimal radial restraining force, if any force at all, and does not affect the shape of the stent **10**, as the suture lies generally flush with the surface of the stent. In addition, the suture **16** is arranged about the
5 circumference of the stent **10** such that the suture is accessible by a hook **30**, which will be described in greater detail below.

The suture **16** is typically threaded along the circumference of the stent **10** proximate to the openings of the stent at the proximal and distal ends, and as shown in FIGS. 5-6, the suture is arranged along a first row of legs **12**. In the
10 embodiment depicted by the Figures, the suture **16** extends between two legs **12**, across a plurality of legs, and then through another set of legs; however, the suture may be intertwined throughout the legs in any number of configurations. FIG. 2 demonstrates that the suture **16** is arranged about the entire circumference of the stent **10** such that the suture may produce a drawstring purse-string effect when
15 pulled on by forceps or a similar instrument. In this regard, the purse-string effect acts against the outward radial force of the stent, and thus, the diameter of the stent is crimped or reduced.

FIG. 3 illustrates that the stent **10** may include ends **20** having apertures **22** defined therein through which the suture **16** may be threaded in order to purse
20 string the stent. However, as depicted in FIG. 4, the stent **10** may also include legs **12** without apertures **22** such that the suture **16** is threaded along the legs **12** as described above. Therefore, the manner in which the suture **16** is arranged about the stent **10** to reduce the outward radial force of the stent is not limited to any specific configuration, as any suitable configuration for causing a purse-string
25 effect on the proximal and/or distal ends of the stent may be employed with the present invention. Furthermore, it is understood that the suture **16** could be arranged in any number of configurations about the circumference of the stent **10** and could be located proximate to one or both ends of the stent.

FIG. 7 illustrates a stent removal device **24** that includes a tube **26**, a pusher
30 **28**, and a hook **30**. The tube **26** includes a cylindrical body **32** and a funnel-shaped end **34**. The cylindrical body **32** is capable of accommodating the pusher **28** and the hook **30** such that the pusher and hook may be moved longitudinally within the cylindrical body and positioned on the stent **10**. The funnel-shaped end **34** of the

tube 36 is capable of receiving at least a portion of the stent 10 when the stent is crimped or constricted, as well as retaining the stent such that the tube may easily reposition or remove the stent from the lumen. The slope of the funnel-shaped end 34 of the tube 36 is angled such that the proximal end of the stent 10 may be readily pulled into the tube. It is understood that the funnel-shaped end 36 could be various configurations in additional embodiments of the present invention, such as a sloped, flared, angled, or similar configuration that is capable of accommodating a respective stent 10. Also for some configurations, the tube 26 need not have any type of enlarged distal end. Moreover, the inner wall of the tube 26 is preferably a low-friction surface to promote movement of the pusher 28 and hook 30 within the tube, as well as receive the proximal end of the stent 10.

The pusher 28 is typically a wire (*e.g.*, stainless steel) that includes a longitudinal portion 36 positioned within the tube 26 and a gripping member 38. The gripping member 38 is capable of engaging an edge of the stent 10 to restrain the stent at its proximal end. Because the pusher 28 is employed to hold the stent 10 in place for subsequent repositioning or removal, the pusher is preferably a rigid wire that is capable of maintaining its shape while restraining the stent, but also having flexibility to be adaptable for a variety of vascular and nonvascular applications. In addition, the gripping member 38 includes a Y-shaped end that extends on either side of the edge of the stent 10. However, FIG. 7a demonstrates that the gripping member 38 may include various configurations that are capable of engaging the stent 10. Thus, the gripping member 38 could be U-shaped, Y-shaped, or asymmetrically U, Y, or L-shaped. In this regard, any suitable configuration of the gripping member 38 may be employed with the present invention that is capable of engaging and restraining the stent 10. Depending on the amount of force applied, the pusher 28 may cause slight distortion of the stent 10 adjacent to the application of force. However, because the stent 10 includes memory material, the stent will return to its original shape when the pusher removes the force.

Furthermore, FIG. 8 illustrates that the pusher 28 may be positioned through the stent 10 such that the gripping member 38 engages the suture 16 located proximate to the distal end of the stent. As such, the pusher 28 may be various lengths such that the gripping member may engage either a proximal end

of the stent **10** or a suture **16** at the distal end of the stent. Similarly, the longitudinal portion **36** of the pusher **28** may be slightly curvilinear, as depicted in FIGS. 7 and 8, or may be substantially linear in alternative embodiments.

The hook **30** is also typically a wire (*e.g.*, stainless steel) that includes a longitudinal portion **40** extending within the tube **26**. The hook **30** further includes a hook member **42** that is capable of partially encircling the suture **16** such that pulling on the hook member causes the suture to purse string and crimp the end of the stent **10**. The stent **10** is flexible, which allows the hook member **42** to access and engage the suture **16** without damaging the stent, suture, and/or lumen. The hook member **42** includes a ridge **44** that secures the suture **16** to prevent the suture from sliding or becoming disengaged by the hook member. The configuration and/or orientation of the hook member **42** is not limited to that depicted in FIGS. 7 and 8, as any suitable hook, snare, claw, or similar configuration could be utilized to engage the suture **16**. Furthermore, the hook **30** is preferably a wire that is of sufficient rigidity to maintain its shape and overcome the outward radial force of the stent **10**, while also having flexibility to be adaptable for a variety of vascular and nonvascular applications.

Thus, FIGS. 7 and 8 generally illustrate the positioning of the tube **26**, pusher **28**, and hook **30** prior to initiating the repositioning or removal of the stent **10**. Thus, when the hook member **42** engages the suture **16**, force applied by the hook **30** in the direction depicted by arrow **48** will cause the suture to purse string or draw down the proximal end of the stent **10**. When the pusher **28** is moved downwardly depicted by arrow **46**, the gripping member **38** will restrain the stent **10** to hold the stent in place while the hook **30** pulls on the suture **16** with the hooking member **42**.

FIGS. 9a-d illustrate the various steps involved in repositioning or removing a stent **10** from a lumen. In FIG. 9a, the gripping member **38** of the pusher **28** is positioned to engage a proximal end of the stent **10**, while the hook member **42** of the hook **30** engages a suture **16** also at the proximal end of the stent. As the pusher **28** is moved downwardly (arrow **46**), the hook **30** pulls upwardly (arrow **48**) on the suture **16** to purse string the suture, causing the proximal end of the stent to crimp or constrict in diameter, as shown in FIG. 9b. As the proximal end of the stent **10** is crimped, the tube **26** may be moved

downwardly (arrow 50) such that the proximal end of the stent is positioned within the funnel-shaped end 34 of the tube (FIG. 9c). The tube 26 may be moved distally to surround only the proximal end of the stent 10, so that the leading edge of the stent in the removal direction cannot engage the lumen or other tissue. The tube 26 may also be moved distally so as to completely surround the stent 10 so that no portion of the stent can drag on the lumen interior wall when the stent is removed. Thereafter, the tube 26, pusher 38, and hook 30 are moved concurrently (arrows 48, 52, 54) to remove or reposition the stent 10, as depicted in FIG. 9d. As described above, the pusher 28 may also be positioned at the distal end of the stent 10 such that the gripping member 38 engages a suture 16 at the distal end of the stent while the hook 30 crimps the proximal end of the stent. The remaining steps for removing or repositioning the stent 10 would be carried out in the same manner as described above. Once the removal device 24 releases the suture 16, the proximal or distal end of the stent 10 will expand to its original diameter.

Therefore, the removal device 24 is capable of repositioning or removing a stent 10 from a lumen while reducing the incidence of damage to the lumen or the stent. As such, the removal device 24 may crimp the stent 10 inside of the tube 26 and then remove the stent rather than removing the stent in its deployed state, *i.e.*, without crimping. The removal device 24 is easily deployed within the lumen and proximate to the implanted stent 10 such that the removal device is capable of being used for various vascular and nonvascular applications.

Many modifications and other embodiments of the invention set forth herein will come to mind to one skilled in the art to which this invention pertains having the benefit of the teachings presented in the foregoing descriptions and the associated drawings. Therefore, it is to be understood that the invention is not to be limited to the specific embodiments disclosed and that modifications and other embodiments are intended to be included within the scope of the appended claims. Although specific terms are employed herein, they are used in a generic and descriptive sense only and not for purposes of limitation.

THAT WHICH IS CLAIMED:

1. A stent removal device for removing or repositioning a stent within a lumen, the stent comprising at least one element arranged circumferentially thereabout, the method comprising:
- 5 a tube positioned within the lumen proximate to the stent, wherein the tube is capable of receiving at least a portion of the stent therein;
- a pusher positioned within the tube and capable of engaging at least one of the stent and the element; and
- 10 a hook positioned within the tube and capable of engaging the element such that a force applied to the hook causes the stent to purse string.
2. The stent removal device according to Claim 1, wherein the tube comprises a funnel-shaped end that is capable of receiving at least a portion of the stent and retaining the stent therein.
- 15 3. The stent removal device according to Claim 1, wherein the pusher comprises a wire including a longitudinal portion and a gripping member.
4. The stent removal device according to Claim 3, wherein the
- 20 longitudinal portion is capable of extending through the tube, and wherein the gripping member is capable of engaging the element or an edge of an opening defined in the stent at a proximal end.
5. The stent removal device according to Claim 3, wherein the
- 25 longitudinal portion is capable of extending through the tube and within the stent, and wherein the gripping member is capable of engaging the element proximate to a distal end of the stent.
6. The stent removal device according to Claim 1, wherein the hook
- 30 comprises a wire including a longitudinal portion and a hook member.

7. The stent removal device according to Claim 6, wherein the longitudinal member is capable of extending through the tube, and wherein the hook member is capable of partially encircling the element.

5 8. A method for removing or repositioning a stent within a lumen, the stent comprising at least one element arranged circumferentially thereabout, the method comprising:

positioning a tube within the lumen proximate to the stent;

positioning a pusher and a hook within the tube;

10 engaging at least one of the stent and the element with the pusher and the hook;

applying a force to the element with the hook such that the hook causes the stent to purse string; and

positioning at least a portion of the stent within the tube.

15

9. The method according to Claim 8, further comprising moving the stent within the lumen while the stent is positioned within the tube.

10. The method according to Claim 8, wherein engaging comprises
20 engaging the element or at least a portion of the stent with the pusher.

11. The method according to Claim 10, wherein engaging comprises engaging an edge of an opening defined in the stent at a proximal end.

25 12. The method according to Claim 8, wherein positioning comprises positioning the pusher within the stent.

13. The method according to Claim 12, wherein engaging comprises engaging the element proximate to a distal end of the stent with the pusher.

30

14. The method according to Claim 8, wherein engaging comprises partially encircling the element with the hook proximate to a distal end or a proximal end of the stent.

15. The method according to Claim 8, further comprising restraining the stent or the element with the pusher during the applying step.

5 16. The method according to Claim 15, wherein restraining comprises applying a distal force to the stent or the element.

17. The method according to Claim 8, wherein applying comprises applying a proximal force to the element with the hook.

10

18. A flexible stent for positioning within a lumen comprising:
a scaffolding of struts, the scaffolding configured to define a generally cylindrical member having openings at a distal end and a proximal end and extending longitudinally therebetween;

15 a cover coupled with the scaffolding such that at least a portion of the struts and an area between the struts are covered; and

at least one element intertwined about a plurality of struts, through a plurality of openings defined in the cover, and at least partially about the circumference of the scaffolding, wherein the element is capable of being engaged
20 to remove or reposition the stent within the lumen.

19. The stent according to Claim 18, wherein the struts comprise a plurality of interconnected legs arranged circumferentially about the stent and a plurality of connectors interconnecting the legs and extending along a longitudinal
25 axis of the stent.

20. The stent according to Claim 18, wherein the at least one element extends through each opening in the cover between a pair of adjacent legs.

30 21. The stent according to Claim 18, wherein at least one leg protrudes outwardly to define a scale.

22. The stent according to Claim 21, wherein each scale extends at an acute angle defined between the at least one leg and an outer surface of the stent.

23. The stent according to Claim 21, wherein each scale extends
5 distally.

24. The stent according to Claim 18, wherein the at least one element is located proximate to at least one of the proximal and distal ends.

10 25. The stent according to Claim 18, wherein each element extends about the entire circumference of the stent.

26. The stent according to Claim 25, wherein each element comprises a pair of free ends that are joined together.

15

27. The stent according to Claim 18, wherein each element lies generally flush with the struts.

28. The stent according to Claim 18, wherein the cover comprises a
20 polyurethane material.

29. The stent according to Claim 18, wherein the at least one element comprises a suture material.

25 30. A stent removal device for removing or repositioning a stent within a lumen, the stent comprising at least one element arranged circumferentially thereabout, the method comprising:

a pusher positioned within the tube and comprising a gripping member for engaging at least one of the stent and the element; and

30 a hook positioned within the tube and capable of engaging the element such that a force applied to the hook causes the stent to purse string.

31. The stent removal device according to Claim 30, wherein the gripping member is capable of engaging the element or an edge of an opening defined in the stent at a proximal end.

5 32. The stent removal device according to Claim 30, wherein the gripping member is capable of engaging the element proximate to a distal end of the stent.

10 33. The stent removal device according to Claim 30, wherein the hook comprises a wire including a longitudinal portion and a hook member.

34. The stent removal device according to Claim 33, wherein the longitudinal member is capable of extending through the tube, and wherein the hook member is capable of partially encircling the element.

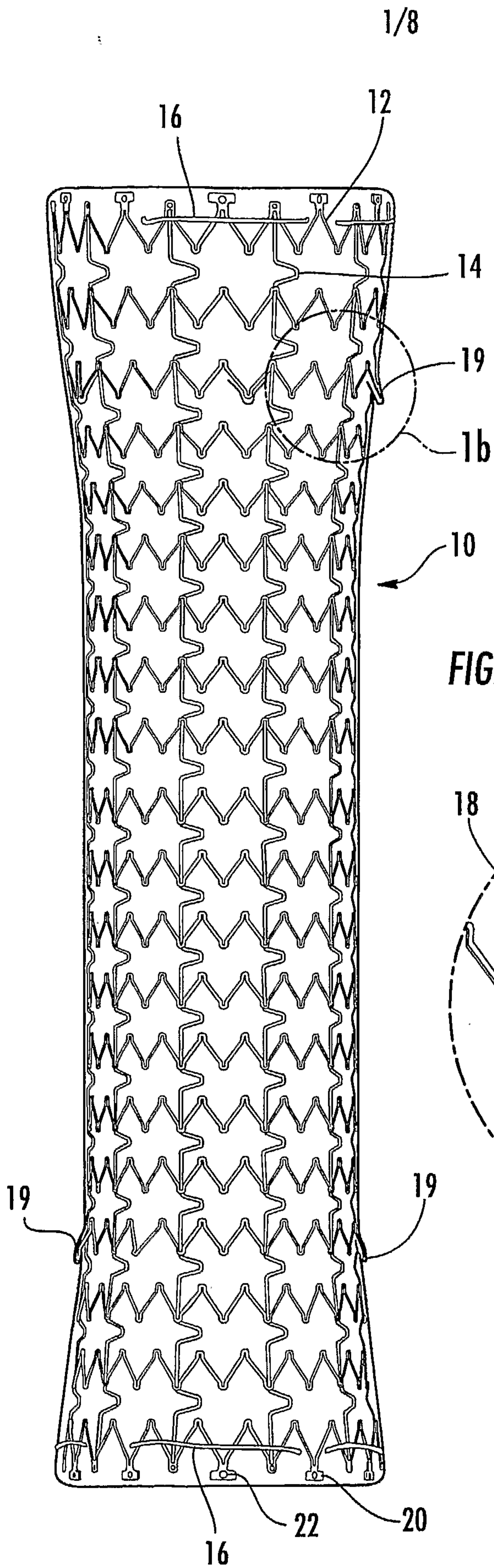

FIG. 1a

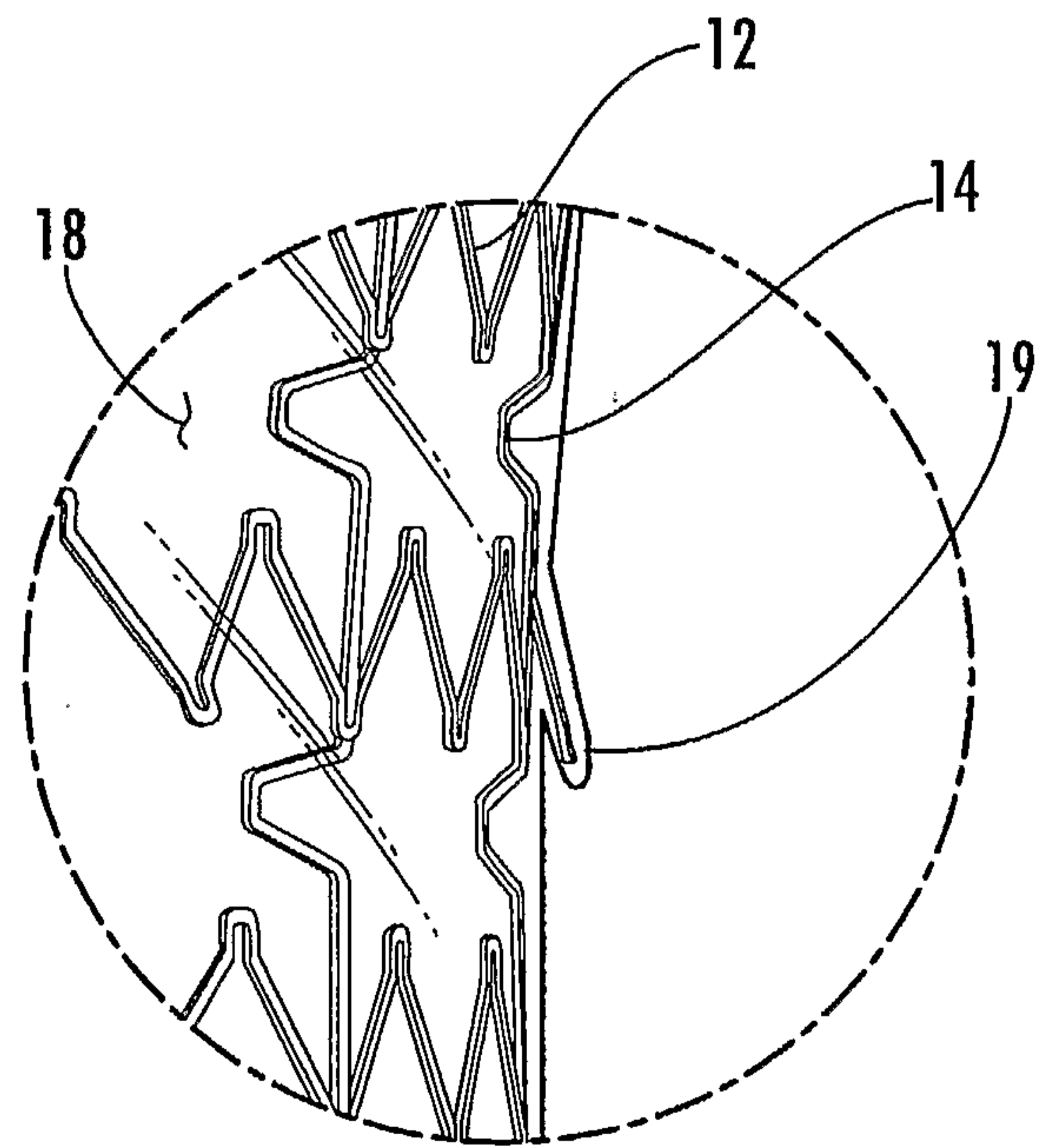

FIG. 1b

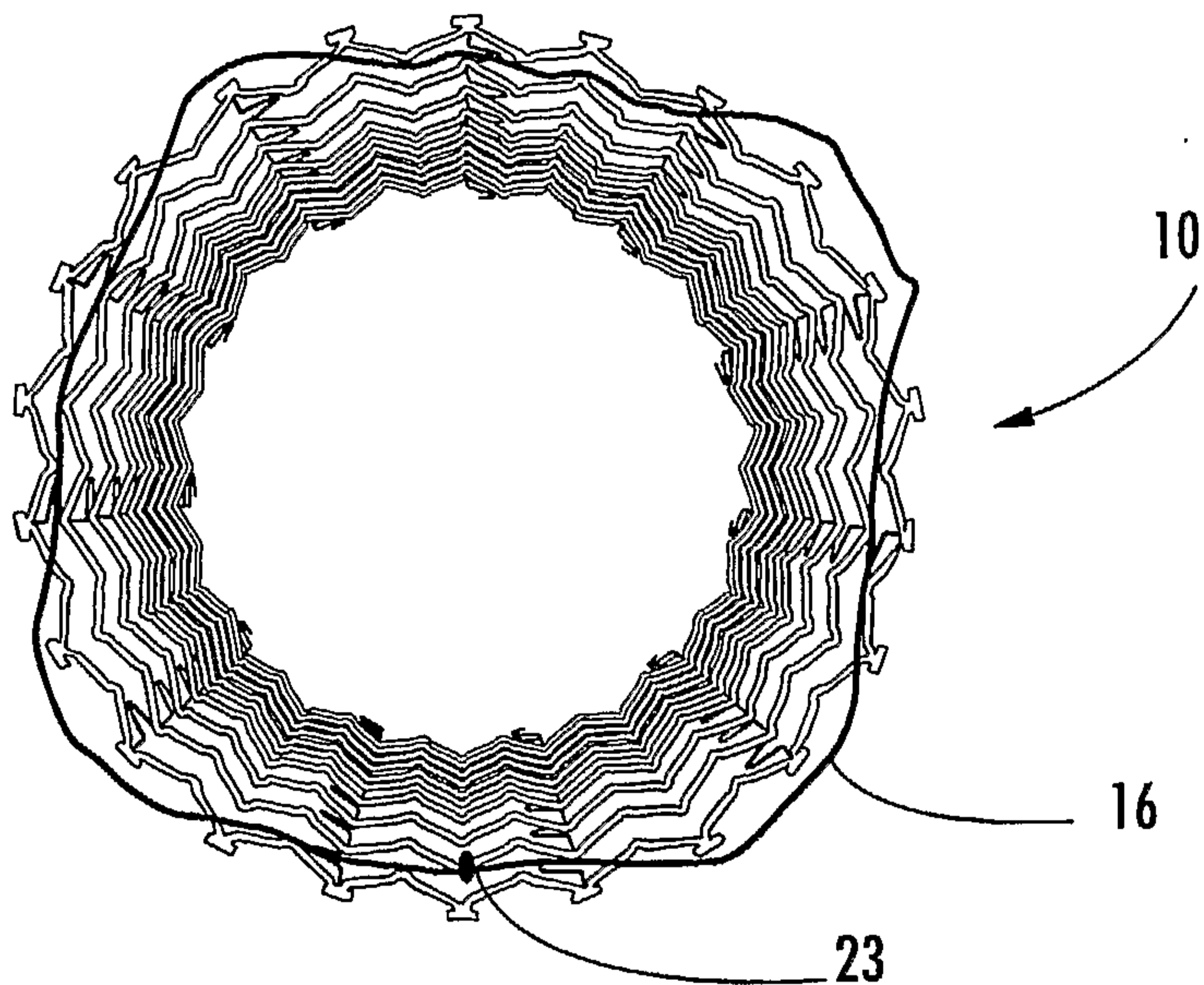

FIG. 2

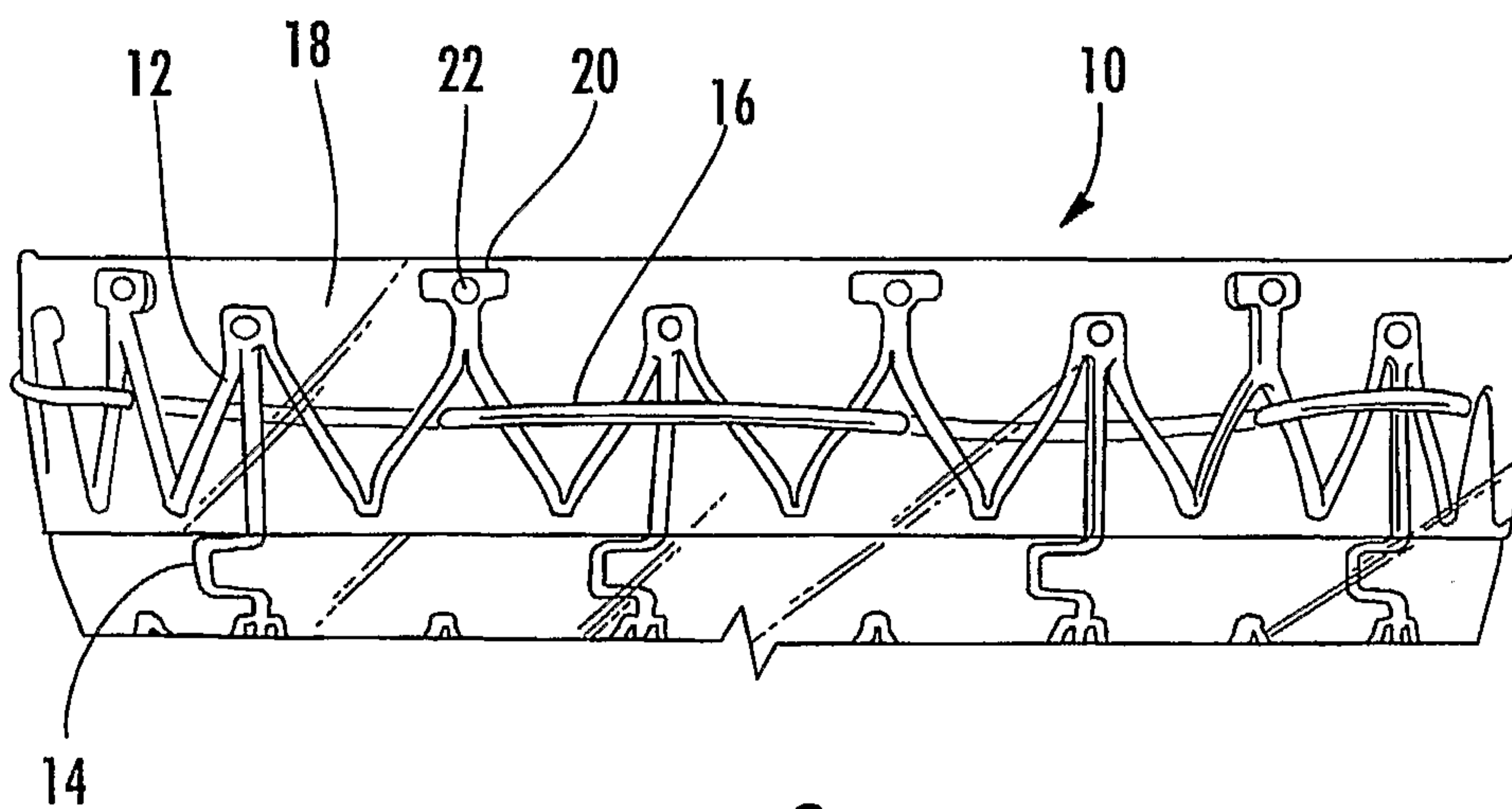

FIG. 3

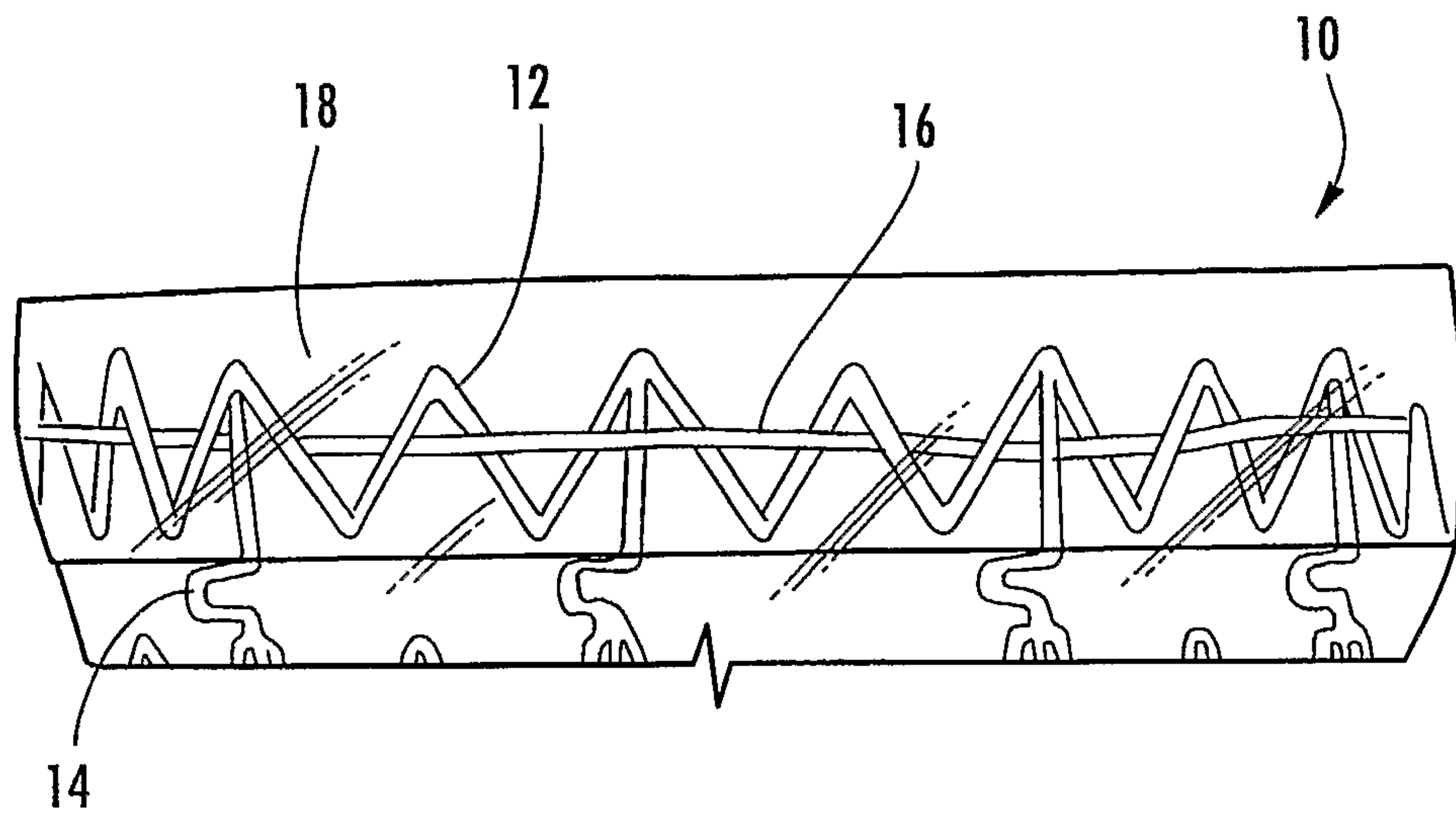

FIG. 4

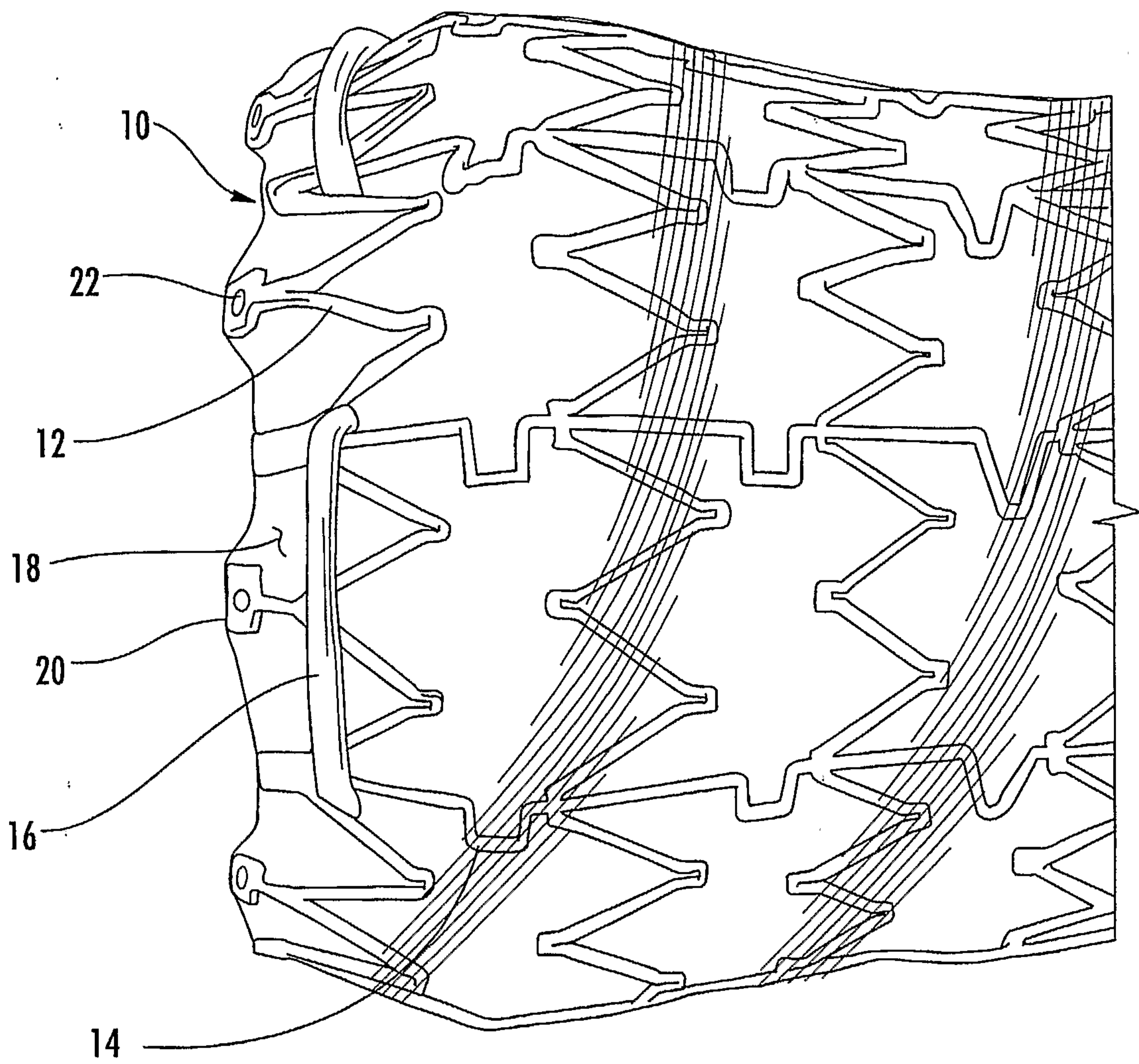

FIG. 5

5/8

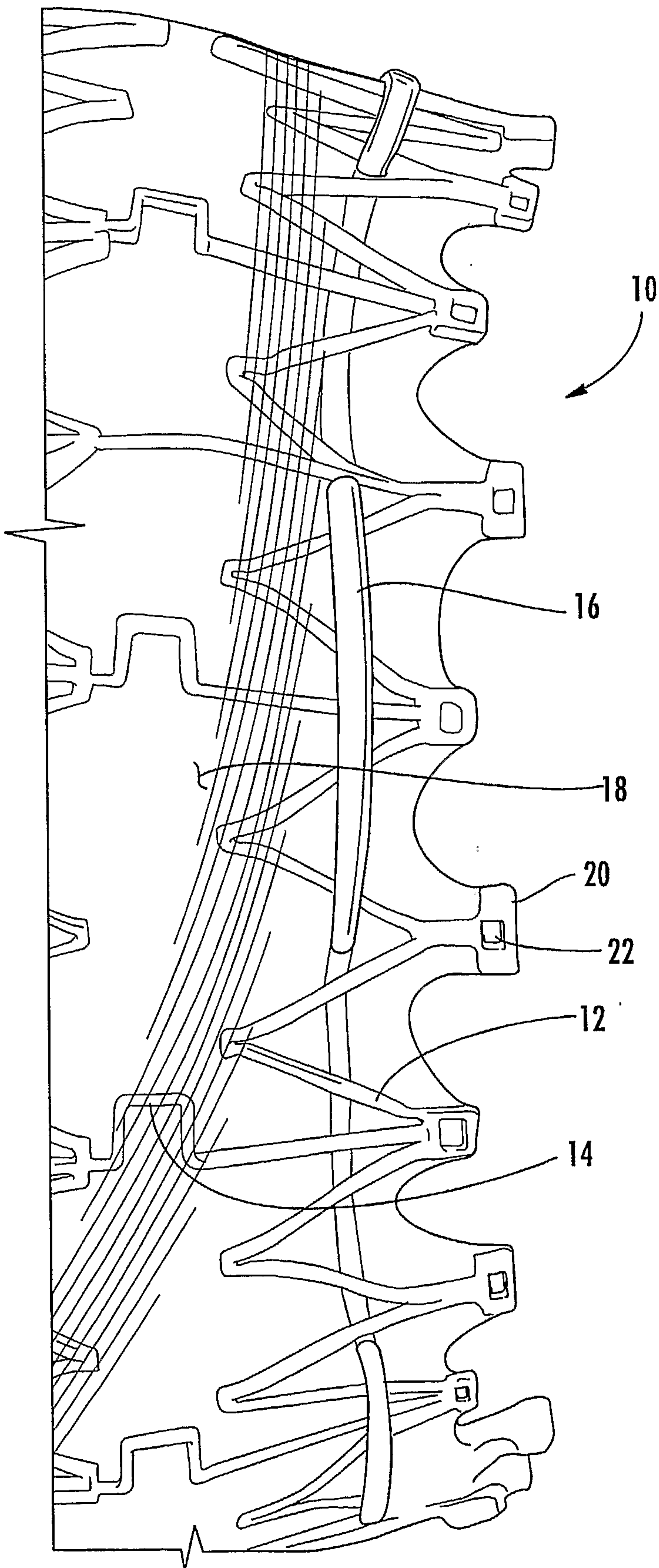

FIG. 6

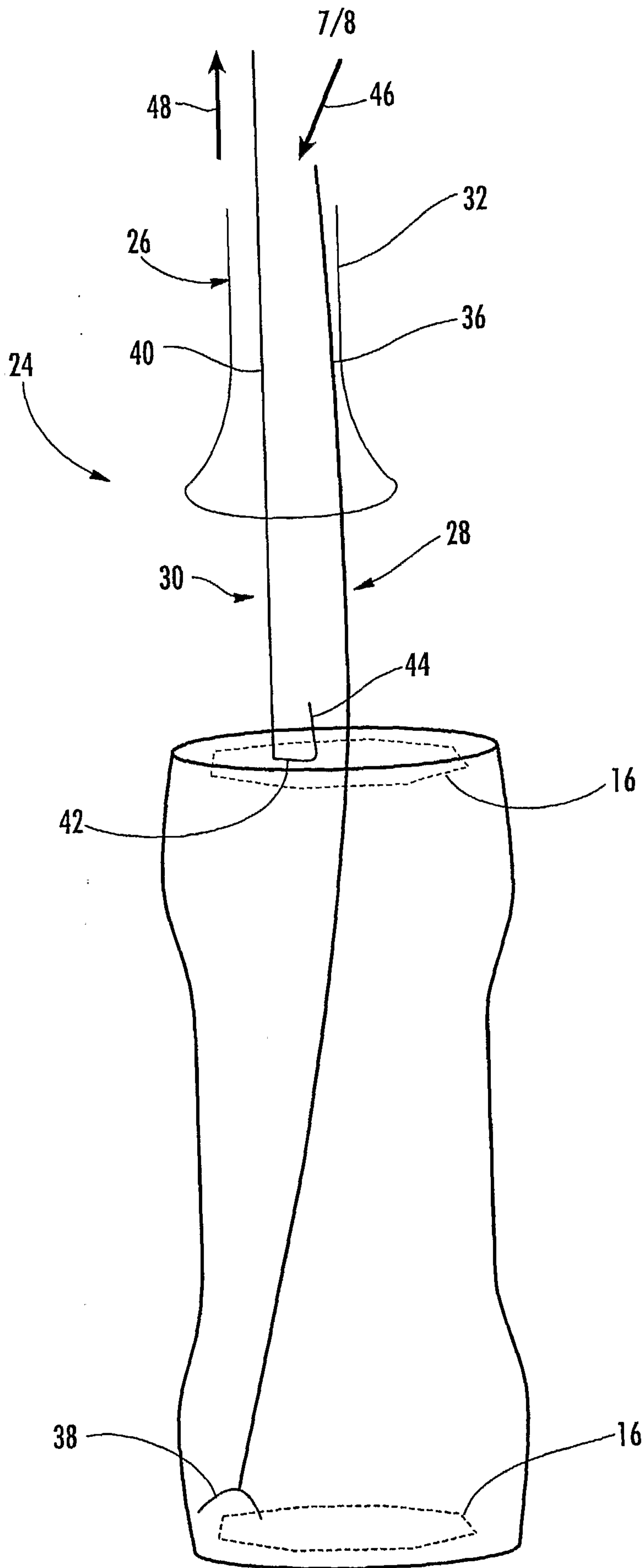

FIG. 8

