

(12) STANDARD PATENT
(19) AUSTRALIAN PATENT OFFICE

(11) Application No. **AU 2018391391 B2**

(54) Title
Base plate for an ostomy appliance and a sensor assembly part for a base plate and a method for manufacturing a base plate and sensor assembly part

(51) International Patent Classification(s)
A61F 5/44 (2006.01) **A61F 5/445** (2006.01)
A61F 5/443 (2006.01)

(21) Application No: **2018391391** (22) Date of Filing: **2018.12.20**

(87) WIPO No: **WO19/120450**

(30) Priority Data

(31) Number	(32) Date	(33) Country
PA 2017 70984	2017.12.22	DK
PA 2017 70998	2017.12.22	DK
PA 2018 70101	2018.02.20	DK

(43) Publication Date: **2019.06.27**

(44) Accepted Journal Date: **2024.03.21**

(71) Applicant(s)
Coloplast A/S

(72) Inventor(s)
HANSEN, Jais Ask; LARSEN, Lars Erup

(74) Agent / Attorney
FB Rice Pty Ltd, L 23 44 Market St, Sydney, NSW, 2000, AU

(56) Related Art
WO 2007/098762 A1
US 6171289 B1



(51) International Patent Classification:

A61F 5/44 (2006.01) A61F 5/445 (2006.01)
A61F 5/443 (2006.01)

(21) International Application Number:

PCT/DK2018/050406

(22) International Filing Date:

20 December 2018 (20.12.2018)

(25) Filing Language:

English

(26) Publication Language:

English

(30) Priority Data:

PA 2017 70984 22 December 2017 (22.12.2017) DK
PA 2017 70998 22 December 2017 (22.12.2017) DK
PA 2018 70101 20 February 2018 (20.02.2018) DK

(71) Applicant: COLOPLAST A/S [DK/DK]; Holtedam 1, 3050 Humlebaek (DK).

(72) Inventors: HANSEN, Jais Ask; Egelundsvej 7, 3630 Jaegerspris (DK). LARSEN, Lars Erup; Soendergaards Alle 45 st.th., 2760 Maaloev (DK).

(81) Designated States (unless otherwise indicated, for every kind of national protection available): AE, AG, AL, AM, AO, AT, AU, AZ, BA, BB, BG, BH, BN, BR, BW, BY, BZ,

CA, CH, CL, CN, CO, CR, CU, CZ, DE, DJ, DK, DM, DO, DZ, EC, EE, EG, ES, FI, GB, GD, GE, GH, GM, GT, HN, HR, HU, ID, IL, IN, IR, IS, JO, JP, KE, KG, KH, KN, KP, KR, KW, KZ, LA, LC, LK, LR, LS, LU, LY, MA, MD, ME, MG, MK, MN, MW, MX, MY, MZ, NA, NG, NI, NO, NZ, OM, PA, PE, PG, PH, PL, PT, QA, RO, RS, RU, RW, SA, SC, SD, SE, SG, SK, SL, SM, ST, SV, SY, TH, TJ, TM, TN, TR, TT, TZ, UA, UG, US, UZ, VC, VN, ZA, ZM, ZW.

(84) Designated States (unless otherwise indicated, for every kind of regional protection available): ARIPO (BW, GH, GM, KE, LR, LS, MW, MZ, NA, RW, SD, SL, ST, SZ, TZ, UG, ZM, ZW), Eurasian (AM, AZ, BY, KG, KZ, RU, TJ, TM), European (AL, AT, BE, BG, CH, CY, CZ, DE, DK, EE, ES, FI, FR, GB, GR, HR, HU, IE, IS, IT, LT, LU, LV, MC, MK, MT, NL, NO, PL, PT, RO, RS, SE, SI, SK, SM, TR), OAPI (BF, BJ, CF, CG, CI, CM, GA, GN, GQ, GW, KM, ML, MR, NE, SN, TD, TG).

(54) Title: BASE PLATE FOR AN OSTOMY APPLIANCE AND A SENSOR ASSEMBLY PART FOR A BASE PLATE AND A METHOD FOR MANUFACTURING A BASE PLATE AND SENSOR ASSEMBLY PART

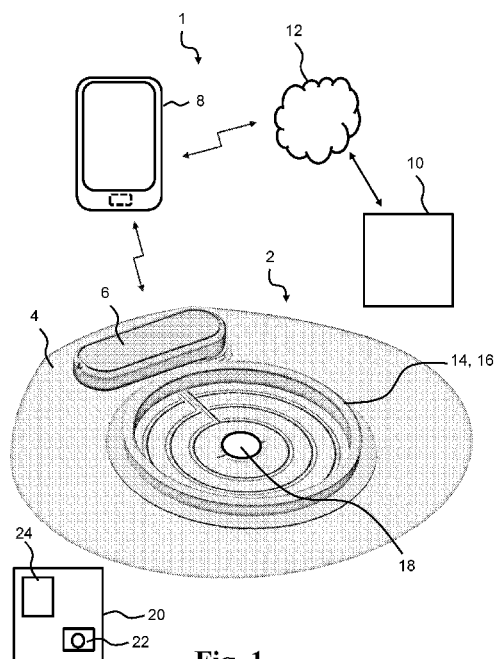

Fig. 1

(57) Abstract: Disclosed is a base plate for an ostomy appliance and a method for manufacturing a base plate. The base plate comprising: a top layer; a first adhesive layer; an electrode assembly comprising a plurality of electrodes, the electrode assembly having a first part and a second part, the first part comprising connection parts of the plurality of electrodes, the second part being arranged between the first adhesive layer and the top layer; and a monitor interface configured for connecting the base plate to a monitor device, the monitor interface comprising a plurality of terminals configured to form electrical connections with respective terminals of the monitor device. The top layer comprises a top layer opening configured to allow for connection between the plurality of electrodes of the electrode assembly and terminals of the monitor device.



Published:

- *with international search report (Art. 21(3))*
- *before the expiration of the time limit for amending the claims and to be republished in the event of receipt of amendments (Rule 48.2(h))*
- *in black and white; the international application as filed contained color or greyscale and is available for download from PATENTSCOPE*

BASE PLATE FOR AN OSTOMY APPLIANCE AND A SENSOR ASSEMBLY PART FOR A BASE PLATE AND A METHOD FOR MANUFACTURING A BASE PLATE AND SENSOR ASSEMBLY PART

5 The present disclosure relates to an ostomy system, devices thereof, method of manufacturing and method for monitoring an ostomy appliance. The ostomy appliance system comprises an ostomy appliance and an ostomy monitor device. In particular, the present disclosure relates to leakage classification and/or detection and monitoring of the operation of an ostomy appliance.

.0 Any discussion of documents, acts, materials, devices, articles or the like which has been included in the present specification is not to be taken as an admission that any or all of these matters form part of the prior art base or were common general knowledge in the field relevant to the present disclosure as it existed before the priority date of each of the appended claims.

.5 **Summary**

According to one aspect of the present disclosure, there is provided a method for manufacturing a base plate for an ostomy appliance, the method comprising:

- providing a top layer;
- providing an electrode assembly comprising a plurality of electrodes, the electrode assembly having a first part and a second part, the first part comprising connection parts of the plurality of electrodes configured for connecting the plurality of electrodes to terminals of a monitor device;

the electrode assembly comprises a support layer,

- providing and/or arranging the plurality of electrodes on the proximal side of the

25 support layer

- providing a first adhesive layer comprising one or more water soluble or water swellable hydrocolloids; and

- assembling the top layer, the electrode assembly and the first adhesive layer, such that the second part of the electrode assembly is arranged between the first adhesive layer and the top layer,

30 the method further comprising:

- providing a top layer opening in the top layer, the top layer opening being configured to allow for connection between the connection parts of the plurality of electrodes and terminals of the monitor device.

According to one aspect of the present disclosure, there is provided a base plate for an ostomy appliance, the base plate comprising:

a top layer;

a first adhesive layer comprising one or more water soluble or water swellable hydrocolloids; and

an electrode assembly comprising a plurality of electrodes, the electrode assembly having a first part and a second part, the first part comprising connection parts of the plurality of electrodes configured for connecting the plurality of electrodes to terminals of a monitor device, the second part being arranged between the first adhesive layer and the top layer;

The electrode assembly comprises a support layer, the plurality of electrodes being provided and/or arranged on the proximal side of the support layer;

a monitor interface configured for connecting the base plate to a monitor device, the monitor interface comprising a plurality of terminals configured to form electrical connections with respective terminals of the monitor device, wherein the top layer comprises a top layer opening configured to allow for connection between the plurality of electrodes of the electrode assembly and terminals of the monitor device.

Throughout this specification the word "comprise", or variations such as "comprises" or "comprising", will be understood to imply the inclusion of a stated element, integer or step, or group of elements, integers or steps, but not the exclusion of any other element, integer or step, or group of elements, integers or steps.

Brief Description of the Drawings

The accompanying drawings are included to provide a further understanding of embodiments and are incorporated into and a part of this specification. The drawings illustrate embodiments and together with the description serve to explain principles of embodiments. Other embodiments and many of the intended advantages of embodiments will be readily appreciated as they become better understood by reference to the following detailed description. The elements of the drawings are not necessarily to scale relative to each other. Like reference numerals designate corresponding similar parts.

Fig. 1 illustrates an exemplary ostomy system,

Fig. 2 illustrates an exemplary monitor device of the ostomy system,

Fig. 3 is an exploded view of a base plate of an ostomy appliance,

Fig. 4 is an exploded view of an exemplary electrode assembly,

Fig. 5 is a proximal view of parts of a base plate and/or a sensor assembly part,

Fig. 6 is a distal view of an exemplary electrode configuration,

Fig. 7 is a distal view of an exemplary masking element,

Fig. 8 is a distal view of an exemplary first adhesive layer,

Fig. 9 is a proximal view of the first adhesive layer of Fig. 8,

Fig. 10 is a distal view of a part of the base plate and/or sensor assembly part including monitor interface,

Fig. 11 illustrates an exploded view of an exemplary base plate,

- Fig. 12 illustrates an exploded view of an exemplary electrode assembly,
Fig. 13 illustrates an exploded view of an exemplary electrode assembly,
Fig. 14 shows an exemplary electrode configuration,
Fig. 15 shows a schematic representation of part of a base plate and/or a sensor
5 assembly part,
Fig. 16 shows a schematic representation of part of a base plate and/or a sensor
assembly part,
Fig. 17 shows a schematic representation of part of a base plate and/or a sensor
assembly part, and
10 Fig. 18 shows a flowchart of an exemplary method.

Detailed Description

Various exemplary embodiments and details are described hereinafter, with reference to the figures when relevant. It should be noted that the figures may or may not be drawn to
15 scale and that elements of similar structures or functions are represented by like reference numerals throughout the figures. It should also be noted that the figures are only intended to facilitate the description of the embodiments. They are not intended as an exhaustive description of the invention or as a limitation on the scope of the invention. In addition, an illustrated embodiment needs not have all the aspects or advantages shown. An aspect or
20 an advantage described in conjunction with a particular embodiment is not necessarily limited to that embodiment and can be practiced in any other embodiments even if not so illustrated, or if not so explicitly described.

Throughout this disclosure, the words “stoma” and “ostomy” are used to denote a surgically created opening bypassing the intestines or urinary tract system of a person.
25 The words are used interchangeably, and no differentiated meaning is intended. The same applies for any words or phrases derived from these, e.g. “stomal”, “ostomies” etc. Also, the solid and liquid wastes emanating from the stoma may be referred to as both stomal “output,” “waste(s),” and “fluids” interchangeably. A subject having undergone ostomy surgery may be referred to as “ostomist” or “ostomate” – moreover, also as
30 “patient” or “user”. However, in some cases “user” may also relate or refer to a health care professional (HCP), such as a surgeon or an ostomy care nurse or others. In those cases, it will either be explicitly stated, or be implicit from the context that the “user” is not the “patient” him- or herself.

In the following, whenever referring to proximal side or surface of a layer, an element, a device or part of a device, the referral is to the skin-facing side or surface, when a user wears the ostomy appliance. Likewise, whenever referring to the distal side or surface of a layer, an element, a device or part of a device, the referral is to the side or surface facing away from the skin, when a user wears the ostomy appliance. In other words, the proximal side or surface is the side or surface closest to the user, when the appliance is fitted on a user and the distal side is the opposite side or surface – the side or surface furthest away from the user in use.

The axial direction is defined as the direction of the stoma, when a user wears the appliance. Thus, the axial direction is generally perpendicular to the skin or abdominal surface of the user.

The radial direction is defined as perpendicular to the axial direction. In some sentences, the words “inner” and “outer” may be used. These qualifiers should generally be perceived with respect to the radial direction, such that a reference to an “outer” element means that the element is farther away from a centre portion of the ostomy appliance than an element referenced as “inner”. In addition, “innermost” should be interpreted as the portion of a component forming a centre of the component and/or being adjacent to the centre of the component. In analogy, “outermost” should be interpreted as a portion of a component forming an outer edge or outer contour of a component and/or being adjacent to that outer edge or outer contour.

The use of the word “substantially” as a qualifier to certain features or effects in this disclosure is intended to simply mean that any deviations are within tolerances that would normally be expected by the skilled person in the relevant field.

The use of the word “generally” as a qualifier to certain features or effects in this disclosure is intended to simply mean – for a structural feature: that a majority or major portion of such feature exhibits the characteristic in question, and – for a functional feature or an effect: that a majority of outcomes involving the characteristic provide the effect, but that exceptionally outcomes do not provide the effect.

The present disclosure relates to an ostomy system and devices thereof, such as an ostomy appliance, a base plate for an ostomy appliance, a monitor device, and optionally one or more accessory devices. Further, methods related to the ostomy system and

- devices thereof are disclosed. An accessory device (also referred to as an external device) may be a mobile phone or other handheld device. An accessory device may be a personal electronic device, e.g. a wearable, such as a watch or other wrist-worn electronic device. An accessory device may be a docking station. The docking station may be
- 5 configured to electrically and/or mechanically couple the monitor device to the docking station. The docking station may be configured for charging the monitor device and/or configured for transferring data between the monitor device and the docking station. The ostomy system may comprise a server device. The server device may be operated and/or controlled by the ostomy appliance manufacturer and/or a service centre.
- 10 The present disclosure provides an ostomy system and devices thereof, such as an ostomy appliance, a base plate for an ostomy appliance, a monitor device, and optionally one or more accessory devices which either alone or together facilitate reliable determination of the nature, severity and rapidness of moisture propagation in the adhesive material provided for attaching the base plate to the skin surface of a user.
- 15 Depending on the nature of the pattern of moisture propagation in the adhesive, the ostomy system and devices thereof enable providing information to the user about the type of failure, and in turn enable providing an indication to the user of the severity and thus the remaining time frame for replacing the ostomy appliance without experiencing severe leakage and/or skin damage.
- 20 The ostomy appliance comprises a base plate and an ostomy pouch (also referred to as an ostomy bag). The ostomy appliance may be a colostomy appliance, an ileostomy appliance or a urostomy appliance. The ostomy appliance may be a two-part ostomy appliance, i.e. the base plate and the ostomy pouch may be releasably coupled e.g. with a mechanical and/or an adhesive coupling, e.g. to allow that a plurality of ostomy pouches
- 25 can be utilized (exchanged) with one base plate. Further, a two-part ostomy appliance may facilitate correct application of the base plate to skin, e.g. to an improved user sight of the stomal region. The ostomy appliance may be a one-part ostomy appliance, i.e. the base plate and the ostomy pouch may be fixedly attached to each other. The base plate is configured for coupling to a user's stoma and/or skin surrounding the stoma, such as a
- 30 peristomal skin area.

The ostomy appliance includes a base plate, such as a monolithic, one-piece base plate, e.g. integrated with a sensor assembly part, or a base plate and a separate sensor assembly part, such as a sensor assembly part to be subsequently applied to a base

plate. For example, to allow an arbitrary base plate, such as a conventional base plate, to achieve the features as described herein. Features as described with respect to the base plate herein may be provided by a sensor assembly part to be applied to a base plate, e.g. by the user. A sensor assembly part may be adapted to adhere to an ostomy plate.

- 5 A disclosed method of attaching a base plate to a user's stoma and/or skin surrounding the stoma, such as the peristomal skin area, may comprise attaching a sensor assembly part to a base plate and attaching the base plate, e.g. together with the attached sensor assembly part, to the user's stoma and/or skin surrounding the stoma, such as the peristomal skin area. Alternatively, the method of attaching the base plate to the user's
- 10 stoma and/or skin surrounding the stoma may comprise attaching the sensor assembly part to the user's stoma and/or skin surrounding the stoma and attaching the base plate to the user's stoma and/or skin surrounding the stoma above the attached sensor assembly part.

The base plate and/or the sensor assembly part comprises a first adhesive layer, also

15 denoted center adhesive layer. During use, the first adhesive layer adheres to the user's skin (peristomal area) and/or to additional seals, such as sealing paste, sealing tape and/or sealing ring. Thus, the first adhesive layer may be configured for attachment of the base plate and/or the sensor assembly part to the skin surface of a user. The first adhesive layer may have a stomal opening, such as a first adhesive stomal opening, with

20 a center point.

The first adhesive layer may be made of a first composition. The first composition may comprise one or more polyisobutenes and/or styrene-isoprene-styrene. The first composition may comprise one or more hydrocolloids.

The first composition may comprise one or more water soluble or water swellable

25 hydrocolloids. The first composition may be a pressure sensitive adhesive composition suitable for medical purposes comprising a rubbery elastomeric base and one or more water soluble or water swellable hydrocolloids. The first composition may comprise one or more polybutenes, one or more styrene copolymers, one or more hydrocolloids, or any combination thereof. The combination of the adhesive properties of the polybutenes and

30 the absorbing properties of the hydrocolloids renders the first composition suitable for use in ostomy appliances. The styrene copolymer may for example be a styrene-butadiene-styrene block copolymer or a styrene-isoprene-styrene block copolymer. Preferably, one

or more styrene-isoprene-styrene (SIS) block type copolymers are employed. The amount of styrene block-copolymer may be from 5% to 20% of the total adhesive composition. The butene component is suitably a conjugated butadiene polymer selected from polybutadiene, polyisoprene. The polybutenes are preferably present in an amount of from 5 35 - 50% of the total adhesive composition. Preferably, the polybutene is polyisobutylene (PIB). Suitable hydrocolloids for incorporation in the first composition are selected from naturally occurring hydrocolloids, semisynthetic hydrocolloids and synthetic hydrocolloids. The first composition may comprise 20-60% hydrocolloids. A preferred hydrocolloid is carboxymethylcellulose (CMC). The first composition may optionally contain other 10 components, such as fillers, tackifiers, plasticizers, and other additives.

The first adhesive layer may have a plurality of sensor point openings. A sensor point opening of the first adhesive layer is optionally configured to overlap a part of an electrode, e.g. to form a sensor point.

The sensor point openings of the first adhesive layer may comprise primary sensor point 15 openings. The primary sensor point openings may comprise one or more primary first sensor point openings and one or more primary second sensor point openings, the primary first sensor point openings configured to overlap parts of an electrode and the primary second sensor point openings configured to overlap parts of another electrode different from the electrode at least partly overlapped by the primary first sensor point 20 openings.

The sensor point openings of the first adhesive layer may comprise secondary sensor point openings. The secondary sensor point openings may comprise one or more secondary first sensor point openings and one or more secondary second sensor point openings, the secondary first sensor point openings configured to overlap parts of an 25 electrode and the secondary second sensor point openings configured to overlap parts of another electrode different from the electrode at least partly overlapped by the secondary first sensor point openings.

The sensor point openings of the first adhesive layer may comprise tertiary sensor point openings. The tertiary sensor point openings may comprise one or more tertiary first 30 sensor point openings and one or more tertiary second sensor point openings, the tertiary first sensor point openings configured to overlap parts of an electrode and the tertiary

second sensor point openings configured to overlap parts of another electrode different from the electrode at least partly overlapped by the tertiary first sensor point openings.

The first adhesive layer may have a substantially uniform thickness. The first adhesive layer may have a thickness in the range from 0.1 mm to 1.5 mm, e.g. in the range from
5 0.2 mm to 1.2 mm.

The first adhesive layer may have a primary thickness in a primary part of the first adhesive layer, e.g. in a primary region within a primary radial distance or in a primary radial distance range from the center point of the stomal opening. The primary thickness may be in the range from 0.2 mm to 1.5 mm, such as about 1.0 mm. The primary radial
10 distance may be in the range from 20 mm to 50 mm, such as in the range from 25 mm to 35 mm, e.g. 30 mm.

The first adhesive layer may have a secondary thickness in a secondary part of the first adhesive layer, e.g. in a secondary region outside a secondary radial distance or in a secondary radial distance range from the center point of the stomal opening. The
15 secondary thickness may be in the range from 0.2 mm to 1.0 mm, such as about 0.5 mm. The secondary radial distance may be in the range from 20 mm to 50 mm, such as in the range from 25 mm to 35 mm, e.g. 30 mm.

The base plate and/or the sensor assembly part may comprise a second layer. The second layer may be a second adhesive layer, also denoted rim adhesive layer. The
20 second layer may have a second radial extension that is larger than a first radial extension of the first adhesive layer at least in a first angular range of the base plate and/or the sensor assembly part. Accordingly, a part of a proximal surface of the second layer may be configured for attachment to the skin surface of a user. The part of a proximal surface of the second layer configured for attachment to the skin surface of a user is also denoted
25 the skin attachment surface of the second adhesive layer. The second layer may have a stomal opening, such as a second layer stomal opening and/or a second adhesive stomal opening, with a center point.

The second adhesive layer may be made of a second composition. The second composition may comprise one or more polyisobutenes and/or styrene-isoprene-styrene.
30 The second composition may comprise one or more hydrocolloids.

The second composition may comprise one or more water soluble or water swellable hydrocolloids. The second composition may be a pressure sensitive adhesive composition suitable for medical purposes comprising a rubbery elastomeric base and one or more water soluble or water swellable hydrocolloids. The second composition may comprise one or more polybutenes, one or more styrene copolymers, one or more hydrocolloids, or any combination thereof. The combination of the adhesive properties of the polybutenes and the absorbing properties of the hydrocolloids renders the second composition suitable for use in ostomy appliances. The styrene copolymer may for example be a styrene-butadiene-styrene block copolymer or a styrene-isoprene-styrene block copolymer. Preferably, one or more styrene-isoprene-styrene (SIS) block type copolymers are employed. The amount of styrene block-copolymer may be from 5% to 20% of the total adhesive composition. The butene component is suitably a conjugated butadiene polymer selected from polybutadiene, polyisoprene. The polybutenes are preferably present in an amount of from 35 - 50% of the total adhesive composition. Preferably, the polybutene is polyisobutylene (PIB). Suitable hydrocolloids for incorporation in the second composition are selected from naturally occurring hydrocolloids, semisynthetic hydrocolloids and synthetic hydrocolloids. The second composition may comprise 20-60% hydrocolloids. A preferred hydrocolloid is carboxymethylcellulose (CMC). The second composition may optionally contain other components, such as fillers, tackifiers, plasticizers, and other additives.

Different ratio of contents may change properties of the first and/or second adhesive layers. The second adhesive layer and the first adhesive layer may have different properties. The second adhesive layer (second composition) and the first adhesive layer (first composition) may have different ratios of polyisobutenes, styrene-isoprene-styrene, and/or hydrocolloids. For example, the second adhesive layer may provide a stronger attachment to the skin compared to attachment to the skin provided by the first adhesive layer. Alternatively or additionally, the second adhesive layer may be thinner than the first adhesive layer. Alternatively or additionally, the second adhesive layer may be less water and/or sweat absorbing than the first adhesive layer. Alternatively or additionally, the second adhesive layer may be less mouldable than the first adhesive layer. The second adhesive layer may provide a second barrier against leakage.

The second layer may have a substantially uniform thickness. The second layer may have a thickness in the range from 0.1 mm to 1.5 mm, e.g. in the range from 0.2 mm to 1.0 mm, such as 0.5 mm, 0.6 mm, or 0.7 mm.

The base plate and/or the sensor assembly part may comprise one or more electrodes, such as a plurality of electrodes, such as two, three, four, five, six, seven or more electrodes. The sensor assembly part may be applied to the base plate, such as to provide the base plate with the one or more electrodes.

- 5 The electrodes, e.g. some or all the electrodes, may be arranged between the first adhesive layer and the second adhesive layer. The electrodes may be arranged in an electrode assembly, e.g. an electrode layer. An electrode comprises a connection part for connecting the electrodes to other components and/or interface terminals. An electrode may comprise one or more conductor parts and/or one or more sensing parts. The
- 10 electrode assembly may be arranged between the first adhesive layer and the second adhesive layer. The base plate and/or the sensor assembly part, e.g. the electrode assembly, may comprise a first electrode, a second electrode and optionally a third electrode. The base plate and/or the sensor assembly part, e.g. the electrode assembly, may comprise a fourth electrode and/or a fifth electrode. The base plate and/or the sensor
- 15 assembly part, e.g. the electrode assembly, optionally comprises a sixth electrode. The base plate and/or the sensor assembly part, e.g. the electrode assembly, may comprise a ground electrode. The ground electrode may comprise a first electrode part. The first electrode part of the ground electrode may form a ground for the first electrode. The ground electrode may comprise a second electrode part. The second electrode part of the
- 20 ground electrode may form a ground for the second electrode. The ground electrode may comprise a third electrode part. The third electrode part of the ground electrode may form a ground for the third electrode. The ground electrode may comprise a fourth electrode part. The fourth electrode part of the ground electrode may form a ground for the fourth electrode and/or the fifth electrode.
- 25 The ground electrode or electrode parts of the ground electrode may be configured as or form a (common) reference electrode for some or all of the other electrodes of the electrode assembly. The ground electrode may also be denoted reference electrode.

- The electrodes are electrically conductive and may comprise one or more of metallic (e.g. silver, copper, gold, titanium, aluminium, stainless steel), ceramic (e.g. ITO), polymeric
- 30 (e.g. PEDOT, PANI, PPy), and carbonaceous (e.g. carbon black, carbon nanotube, carbon fibre, graphene, graphite) materials.

Two electrodes of the electrode assembly may form a sensor. The first electrode and the ground electrode (e.g. first electrode part of the ground electrode) may form a first sensor or first electrode pair. The second electrode and the ground electrode (e.g. second electrode part of the ground electrode) may form a second sensor or second electrode pair. The third electrode and the ground electrode (e.g. third electrode part of the ground electrode) may form a third sensor or third electrode pair. The fourth electrode and the ground electrode (e.g. fourth electrode part of the ground electrode) may form a fourth sensor or fourth electrode pair. The fifth electrode and the ground electrode (e.g. fifth electrode part of the ground electrode) may form a fifth sensor or fifth electrode pair.

10

The first electrode may form an open loop. The second electrode may form an open loop and/or the third electrode may form an open loop. The fourth electrode may form an open loop. The fifth electrode may form an open loop. Open loop electrode(s) enables electrode arrangement in few or a single electrode layer.

15 The electrode assembly may comprise a support layer, also denoted a support film. One or more electrodes may be formed, e.g. printed, on the proximal side of the support layer. One or more electrodes may be formed, e.g. printed, on the distal side of the support layer. The electrode assembly, such as the support layer of the electrode assembly, may have a stomal opening, such as an electrode assembly stomal opening and/or a support layer stomal opening, with a center point.

20

The support layer may comprise polymeric (e.g. polyurethane, PTFE, PVDF) and/or ceramic (e.g. alumina, silica) materials. In one or more exemplary base plates and/or sensor assembly parts, the support layer is made of thermoplastic polyurethane (TPU). The support layer material may be made of or comprise one or more of polyester, a thermoplastic elastomer (TPE), polyamide, polyimide, Ethylene-vinyl acetate (EVA), polyurea, and silicones.

25

Exemplary thermoplastic elastomers of the support layer are styrenic block copolymers (TPS, TPE-s), thermoplastic polyolefinelastomers (TPO, TPE-o), thermoplastic Vulcanizates (TPV, TPE-v), thermoplastic polyurethanes (TPU), thermoplastic copolyester (TPC, TPE-E), and thermoplastic polyamides (TPA, TPE-A).

30

The base plate and/or the sensor assembly part, such as the electrode assembly may comprise a masking element configured to insulate at least parts of the electrodes from

the first adhesive layer of the base plate and/or the sensor assembly part. The masking element may comprise one or more, such as a plurality of, sensor point openings. The sensor point openings may comprise primary sensor point openings and/or secondary sensor point openings. The sensor point openings may comprise tertiary sensor point opening(s). The sensor point openings may comprise quaternary sensor point opening(s). A sensor point opening of the masking element overlaps at least one electrode of the electrode assembly when seen in the axial direction, e.g. to form a sensor point. For example, a primary sensor point opening may overlap a part of the ground electrode and/or a part of the fourth electrode. A secondary sensor point opening may overlap a part of the fourth electrode and/or a part of the fifth electrode. A tertiary sensor point opening may overlap a part of the fifth electrode and/or a part of the ground electrode.

The masking element may comprise one or more, such as a plurality of, terminal openings. The masking element may comprise polymeric (e.g. polyurethane, PTFE, PVDF) and/or ceramic (e.g. alumina, silica) materials. In one or more exemplary base plates and/or sensor assembly parts, the masking element is made of or comprises thermoplastic polyurethane (TPU). In one or more exemplary base plates and/or sensor assembly parts, the masking element is made of or comprises polyester. The masking element material may be made of or comprise one or more of polyester, a thermoplastic elastomer (TPE), polyamide, polyimide, Ethylene-vinyl acetate (EVA), polyurea, and silicones.

Exemplary thermoplastic elastomers of the masking element are styrenic block copolymers (TPS, TPE-s), thermoplastic polyolefinelastomers (TPO, TPE-o), thermoplastic Vulcanizates (TPV, TPE-v), thermoplastic polyurethanes (TPU), thermoplastic copolyester (TPC, TPE-E), and thermoplastic polyamides (TPA, TPE-A).

The base plate and/or the sensor assembly part may comprise a first intermediate element. The first intermediate element may be arranged between the electrodes/electrode layer and the first adhesive layer and/or between the second layer and the first adhesive layer. The first intermediate layer may be made of an insulating material.

The base plate and/or the sensor assembly part may comprise a release liner. The release liner is a protective layer that protects adhesive layer(s) during transport and storage and is peeled off by the user prior to applying the base plate and/or the sensor

assembly part on the skin. The release liner may have a stomal opening, such as a release liner stomal opening, with a center point.

The base plate and/or the sensor assembly part may comprise a top layer. The top layer is a protective layer protecting the adhesive layer(s) from external strains and stress when the user wears the ostomy appliance. The electrodes, e.g. some or all the electrodes, may be arranged between the first adhesive layer and the top layer. The top layer may have a stomal opening, such as a top layer stomal opening, with a center point. The top layer may have a thickness in the range from 0.01 mm to 1.0 mm, e.g. in the range from 0.02 mm to 0.2 mm, such as 0.04 mm.

10 The base plate and/or the sensor assembly part may comprise a monitor interface. The monitor interface may be configured for electrically and/or mechanically connecting the ostomy appliance (base plate and/or sensor assembly part) to the monitor device. The monitor interface may be configured for wirelessly connecting the ostomy appliance (base plate and/or sensor assembly part) to the monitor device. Thus, the monitor interface of
15 the base plate and/or the sensor assembly part is configured to electrically and/or mechanically couple the ostomy appliance and the monitor device.

The monitor interface of the base plate and/or the sensor assembly part may comprise, e.g. as part of a first connector of the monitor interface, a coupling part for forming a mechanical connection, such as a releasable coupling between the monitor device and
20 the base plate and/or the sensor assembly part. The coupling part may be configured to engage with a coupling part of the monitor device for releasably coupling the monitor device to the base plate and/or the sensor assembly part.

The monitor interface of the base plate and/or the sensor assembly part may comprise, e.g. as part of a first connector of the monitor interface, a plurality of terminals, such as
25 two, three, four, five, six, seven or more terminals, for forming electrical connections with respective terminals of the monitor device. The monitor interface may comprise a ground terminal element forming a ground terminal. The monitor interface may comprise a first terminal element forming a first terminal, a second terminal element forming a second terminal and optionally a third terminal element forming a third terminal. The monitor
30 interface may comprise a fourth terminal element forming a fourth terminal and/or a fifth terminal element forming a fifth terminal. The monitor interface optionally comprises a sixth terminal element forming a sixth terminal. The terminal elements of the monitor

interface may contact respective electrodes of the base plate and/or the sensor assembly part, such as the electrode assembly of the base plate and/or the sensor assembly part. The first intermediate element may be arranged between the terminal elements and the first adhesive layer. The first intermediate element may cover or overlap terminal
5 element(s) of the base plate and/or the sensor assembly part when seen in the axial direction. Thus, the first adhesive layer may be protected or experience more evenly distributed mechanical stress from the terminal elements of the base plate and/or the sensor assembly part, in turn reducing the risk of terminal elements penetrating or otherwise damaging the first adhesive layer. The first intermediate element may protect or
10 mechanically and/or electrically shield the first adhesive layer from the terminal elements of the base plate and/or the sensor assembly part.

A terminal element, such as the ground terminal element, the first terminal element, the second terminal element, the third terminal element, the fourth terminal element, the fifth terminal element and/or the sixth terminal element, may comprise a distal end and a
15 proximal end. A terminal element, such as the ground terminal element, the first terminal element, the second terminal element, the third terminal element, the fourth terminal element, the fifth terminal element and/or the sixth terminal element, may comprise a distal part, a centre part, and/or a proximal part. The distal part may be between the distal end and the centre part. The proximal part may be between the proximal end and the
20 centre part. A terminal element, such as the ground terminal element, the first terminal element, the second terminal element, the third terminal element, the fourth terminal element, the fifth terminal element and/or the sixth terminal element, may be gold plated copper.

The base plate may comprise a coupling ring or other coupling member for coupling an
25 ostomy pouch to the base plate (two-part ostomy appliance). The center point may be defined as a center of the coupling ring.

The base plate and/or the sensor assembly part may have a stomal opening, e.g. with a center point. The stomal opening of the base plate and/or the sensor assembly part may be formed collectively of stomal opening(s) of the layers of the base plate and/or the
30 sensor assembly part, such as of the top layer, the first adhesive layer, the second layer and/or the sensor assembly part. The stomal opening(s) of the layers of the base plate and/or the sensor assembly part, such as of the top layer, the first adhesive layer, the second layer and/or the sensor assembly part may be aligned to form the stomal opening

of the base plate and/or the sensor assembly part. The stomal opening may be a through-going passage of the base plate and/or the sensor assembly part. The stomal opening may be arranged substantially in the center of the base plate and/or the sensor assembly part. The stomal opening(s) of the layers of the base plate and/or the sensor assembly part may be arranged substantially in the center of the respective layer. The stomal opening may be configured to receive a stoma of the user and/or the stomal opening may be configured to allow output from the stoma to pass through the stomal opening and into an ostomy pouch attached to the base plate. For example, the stomal opening may be configured to allow passage of output from a proximal side of the base plate and/or sensor assembly part to a distal side of the base plate and/or sensor assembly part. The size and/or shape of the stomal opening may typically be adjusted by the user or nurse before application of the ostomy appliance to accommodate the user's stoma. In one or more exemplary base plates or sensor assembly parts, the user forms the stomal opening during preparation of the base plate and/or the sensor assembly part for application.

15 The monitor device comprises a processor and one or more interfaces, such as a first interface and/or a second interface. The monitor device may comprise a memory for storing ostomy data.

In one or more exemplary monitor devices, the processor is configured to apply a processing scheme, the first interface is connected to the processor and the memory, and the first interface is configured for collecting ostomy data from the base plate and/or the sensor assembly part coupled to the first interface. The ostomy data may comprise one or more, such as all, of first ostomy data from a first electrode pair of the base plate and/or the sensor assembly part, second ostomy data from a second electrode pair of the base plate and/or the sensor assembly part, and third ostomy data from a third electrode pair of the base plate and/or the sensor assembly part. A second interface is connected to the processor. To apply a processing scheme may comprise one or more of obtain first parameter data based on the first ostomy data; obtain second parameter data based on the second ostomy data; and obtain third parameter data based on the third ostomy data. To apply a processing scheme may comprise determine an operating state of the base plate of the ostomy appliance based on one or more, such as all, of the first parameter data, the second parameter data and the third parameter data. The operating state may be indicative of a degree of radial erosion of the base plate and/or the sensor assembly part, such as of the first adhesive layer, and/or an acute leakage risk for the ostomy appliance. The monitor device is configured to, in accordance with a determination that the operating state is a first operating state, transmit a first monitor signal comprising

monitor data indicative of the first operating state of the base plate via the second interface; and/or in accordance with a determination that the operating state is a second operating state, transmit a second monitor signal comprising monitor data indicative of the second operating state of the base plate via the second interface.

5

In one or more exemplary monitor devices, the first operating state of the base plate corresponds to a situation wherein the first adhesive layer of the base plate and/or the sensor assembly part has experienced a first degree of radial erosion, e.g. the first adhesive layer is eroded to a first radial distance of the first electrode pair but not to a

10 second radial distance of the second electrode pair.

In one or more exemplary monitor devices, the second operating state of the base plate corresponds to a situation wherein the first adhesive layer of the base plate and/or the sensor assembly part has experienced a second degree of radial erosion, e.g. the first adhesive layer is eroded to the second radial distance of the second electrode pair but not

15 to a third radial distance of the third electrode pair.

To obtain first parameter data based on the first ostomy data may comprise determining one or more first parameters based on the first ostomy data. To obtain second parameter data based on the second ostomy data may comprise determining one or more second parameters based on the second ostomy data. To obtain third parameter data based on

20 the third ostomy data may comprise determining one or more third parameters based on the third ostomy data. In one or more exemplary monitor devices, determination of an operating state may be based on one or more first parameters, such as first primary parameter and/or first secondary parameter of first parameter data. In one or more

25 exemplary monitor devices, determination of an operating state may be based on one or more second parameters, such as second primary parameter and/or second secondary parameter of the second parameter data. In one or more exemplary monitor devices, determination of an operating state may be based on one or more third parameters, such as third primary parameter and/or third secondary parameter of the third parameter data.

In one or more exemplary monitor devices, determination of an operating state may be

30 based on one or more fourth parameters, such as fourth primary parameter and/or fourth secondary parameter of the fourth parameter data.

The first parameter data, the second parameter data, and the third parameter data may be indicative of resistance between the first electrode pair, the second electrode pair, and the third electrode pair, respectively.

- 5 The first parameter data, the second parameter data, and the third parameter data may be indicative of a rate of change in resistance between the first electrode pair, the second electrode pair, and the third electrode pair, respectively.

10 In one or more exemplary monitor devices, to determine an operating state of the base plate is based on a first criteria set based on the first parameter data and/or the second parameter data, wherein the operating state is determined to be the first operating state if the first criteria set is satisfied. The first criteria set may comprise one or more first criteria based on one or more of first parameter data, second parameter data and third parameter data. The first criteria set may comprise a first primary criterion based on the first
15 parameter data. The first criteria set may comprise a first secondary criterion based on the second parameter data. The first criteria set may comprise a first tertiary criterion based on the third parameter data.

In one or more exemplary monitor devices, to determine an operating state of the base
20 plate may be based on a first threshold set comprising one or a plurality of first threshold values. The first threshold set may comprise one or a plurality of threshold values, e.g. to be applied in the first criteria set. The first threshold set may comprise a first primary threshold value. The first threshold set may comprise a first secondary threshold value. The first threshold set may comprise a first tertiary threshold value.

25

The first criteria set may be given by

$$\begin{aligned} & (P_{1_1} < TH_{1_1}), \\ & (P_{2_1} > TH_{1_2}), \text{ and} \\ & (P_{3_1} > TH_{1_3}), \end{aligned}$$

30 wherein P_{1_1} is a first primary parameter based on the first parameter data, TH_{1_1} is a first primary threshold value, P_{2_1} is a second primary parameter based on the second parameter data, TH_{1_2} is a first secondary threshold value, P_{3_1} is a third primary parameter based on the third parameter data, and TH_{1_3} is a first tertiary threshold value, and wherein the first operating state is indicative of low degree of radial erosion on
35 the base plate and/or the sensor assembly part. The first threshold values (TH_{1_1} , TH_{1_2} and TH_{1_3}) may be the same or different, e.g. depending on the electrode

configuration of the base plate and/or the sensor assembly part. The first tertiary criterion ($P_{3_1} < TH_{1_3}$) may be omitted in the first criteria set.

5 The first primary parameter P_{1_1} may be indicative of the resistance between the first electrode pair (first electrode and first electrode part of the ground electrode) of the base plate and/or the sensor assembly part.

10 The second primary parameter may be indicative of the resistance between the second electrode pair (second electrode and second electrode part of the ground electrode) of the base plate and/or the sensor assembly part.

15 The third primary parameter may be indicative of resistance between the third electrode pair (third electrode and third electrode part of the ground electrode) of the base plate and/or the sensor assembly part.

In one or more exemplary monitor devices, to determine an operating state of the base plate is based on a second criteria set based on the second parameter data and/or the third parameter data, wherein the operating state is determined to be the second operating state if the second criteria set is satisfied. The second criteria set may be based on the first parameter data.

20 The second criteria set may comprise one or more second criteria based on one or more of first parameter data, second parameter data and third parameter data. The second criteria set may comprise a second primary criterion based on the first parameter data.

25 The second criteria set may comprise a second secondary criterion based on the second parameter data. The second criteria set may comprise a second tertiary criterion based on the third parameter data.

30 In one or more exemplary monitor devices, to determine an operating state of the base plate is based on a second threshold set comprising one or a plurality of second threshold values. The second threshold set may comprise one or a plurality of threshold values, e.g. to be applied in the second criteria set. The second threshold set may comprise a second primary threshold value. The second threshold set may comprise a second secondary threshold value. The second threshold set may comprise a second tertiary threshold value.

35

The second criteria set may be given by

$$(P_{1_1} < TH_{2_1}),$$

$$(P_{2_1} < TH_{2_2}), \text{ and}$$

$$(P_{3_1} > TH_{2_3})$$

- 5 wherein P_{1_1} is a first primary parameter based on the first parameter data and indicative of the resistance between the first electrode pair, TH_{2_1} is a second primary threshold value, P_{2_1} is a second primary parameter based on the second parameter data and indicative of the resistance between the second electrode pair, TH_{2_2} is a second secondary threshold value, P_{3_1} is a third primary parameter based on the third
 10 parameter data and indicative of the resistance between the third electrode pair, TH_{2_3} is a second tertiary threshold value, and wherein the second operating state is indicative of medium degree of radial erosion on the base plate and/or the sensor assembly part. The second threshold values (TH_{2_1} , TH_{2_2} and TH_{2_3}) may be the same or different, e.g. depending on the electrode configuration of the base plate and/or the
 15 sensor assembly part. The second primary criterion ($P_{1_1} < TH_{2_1}$) and/or the second tertiary criterion ($P_{3_1} > TH_{2_3}$) may be omitted in the second criteria set.

In one or more exemplary monitor devices, to determine an operating state of the base plate is based on a default criteria set based on the first parameter data, wherein the
 20 operating state is determined to be the default operating state if the default criteria set is satisfied, and in accordance with a determination that the operating state is the default operating state, transmit a default monitor signal comprising monitor data indicative of the default operating state of the ostomy appliance.

25 The default criteria set may be given by

$$(P_{1_1} > TH_{D_1}),$$

$$(P_{2_1} > TH_{D_2}), \text{ and}$$

$$(P_{3_1} > TH_{D_3})$$

wherein P_{1_1} is a first primary parameter based on the first parameter data and
 30 indicative of the resistance between the first electrode pair, TH_{D_1} is a default primary threshold value, P_{2_1} is a second primary parameter based on the second parameter data and indicative of the resistance between the second electrode pair, TH_{D_2} is a default secondary threshold value, P_{3_1} is a third primary parameter based on the third parameter data and indicative of the resistance between the third electrode pair, TH_{D_3}
 35 is a default tertiary threshold value, and wherein the default operating state is indicative of very low or no degree of radial erosion on the base plate and/or the sensor assembly part.

The default threshold values (TH_D_1, TH_D_2 and TH_D_3) may be the same or different, e.g. depending on the electrode configuration of the base plate and/or the sensor assembly part.

- 5 In one or more exemplary monitor devices, to determine an operating state of the base plate is based on a third criteria set based on the third parameter data, wherein the operating state is determined to be the third operating state if the third criteria set is satisfied, and in accordance with a determination that the operating state is the third operating state, transmit a third monitor signal comprising monitor data indicative of the
10 third operating state of the ostomy appliance.

In one or more exemplary monitor devices, the third operating state of the base plate corresponds to a situation wherein the first adhesive layer of the base plate and/or the sensor assembly part has experienced a third degree of radial erosion, e.g. the first
15 adhesive layer is eroded to the third radial distance of the third electrode pair.

The third criteria set may be given by

$$\begin{aligned} & (P_{1_1} < TH_{3_1}), \\ & (P_{2_1} < TH_{3_2}), \text{ and} \\ & (P_{3_1} < TH_{3_3}) \end{aligned}$$

- 20 wherein P_{1_1} is a first primary parameter based on the first parameter data and indicative of the resistance between the first electrode pair, TH_{3_1} is a third primary threshold value, P_{2_1} is a second primary parameter based on the second parameter data and indicative of the resistance between the second electrode pair, TH_{3_2} is a third secondary threshold value, P_{3_1} is a third primary parameter based on the third
25 parameter data and indicative of the resistance between the third electrode pair, TH_{3_3} is a third tertiary threshold value, and wherein the third operating state is indicative of high degree of radial erosion on the base plate and/or the sensor assembly part. The third threshold values (TH_{3_1}, TH_{3_2} and TH_{3_3}) may be the same or different, e.g. depending on the electrode configuration of the base plate and/or the sensor assembly
30 part. The third primary criterion (P_{1_1} < TH_{3_1}) and/or the third secondary criterion (P_{2_1} < TH_{3_2}) may be omitted in the third criteria set.

In one or more exemplary monitor devices, the ostomy data comprises fourth ostomy data from a fourth electrode pair of the base plate and/or the sensor assembly part. To apply a

processing scheme may comprise to obtain fourth parameter data based on the fourth ostomy data, and determine an operating state of the base plate of the ostomy appliance based on the fourth parameter data. The monitor device may be configured to, in accordance with a determination that the operating state is a fourth operating state, 5 transmit a fourth monitor signal comprising monitor data indicative of the fourth operating state of the ostomy appliance.

In one or more exemplary monitor devices, the fourth operating state of the base plate corresponds to a situation, wherein the fourth electrode pair detects fluid, such as output, 10 between the distal surface of first adhesive layer and the skin of the user at a fourth radial distance, and thus there is a high risk of leakage from the ostomy appliance in the fourth operating state.

The fourth criteria set may be given by

15
$$(P_{4_1} < TH_{4_4})$$

wherein P_{4_1} is a fourth primary parameter based on the fourth parameter data and indicative of the resistance between the fourth electrode pair and TH_{4_4} is a fourth quaternary threshold value, and wherein the fourth operating state is indicative of high risk of leakage from the ostomy appliance.

20 The monitor device comprises a monitor device housing optionally made of a plastic material. The monitor device housing may be an elongate housing having a first end and a second end. The monitor device housing may have a length or maximum extension along a longitudinal axis in the range from 1 cm to 15 cm. The monitor device housing may have a width or maximum extension perpendicular to the longitudinal axis in the range from 0.5 25 cm to 3 cm. The monitor device housing may be curve-shaped.

The monitor device comprises a first interface. The first interface may be configured as an appliance interface for electrically and/or mechanically connecting the monitor device to the ostomy appliance. Thus, the appliance interface is configured to electrically and/or mechanically couple the monitor device and the ostomy appliance. The first interface may 30 be configured as an accessory device interface for electrically and/or mechanically connecting the monitor device to an accessory device, such as a docking station. The first interface may be configured for coupling to a docking station of the ostomy system, e.g. for charging the monitor device and/or for data transfer between the monitor device and the docking station.

The first interface of the monitor device may comprise a plurality of terminals, such as two, three, four, five, six, seven or more terminals, for forming electrical connections with respective terminals and/or electrodes of the ostomy appliance. One or more terminals of the first interface may be configured for forming electrical connections with an accessory device, e.g. with respective terminals of a docking station. The first interface may comprise a ground terminal. The first interface may comprise a first terminal, a second terminal and optionally a third terminal. The first interface may comprise a fourth terminal and/or a fifth terminal. The first interface optionally comprises a sixth terminal. In one or more exemplary monitor devices, the first interface has M terminals, wherein M is an integer in the range from 4 to 8.

The first interface of the monitor device may comprise a coupling part (may alternatively be denoted a device coupling part or a monitor device coupling part) for forming a mechanical connection, such as a releasable coupling between the monitor device and the base plate and/or the sensor assembly part. The coupling part and the terminals of the first interface form (at least part of) a first connector of the monitor device.

The monitor device comprises a power unit for powering the monitor device. The power unit may comprise a battery. The power unit may comprise charging circuitry connected to the battery and terminals of the first interface for charging the battery via the first interface, e.g. the first connector. The first interface may comprise separate charging terminal(s) for charging the battery.

The monitor device may comprise a sensor unit with one or more sensor. The sensor unit is connected to the processor for feeding sensor data to the processor. The sensor unit may comprise an accelerometer for sensing acceleration and provision of acceleration data to the processor. The sensor unit may comprise a temperature sensor for provision of temperature data to the processor.

The monitor device comprises a second interface connected to the processor. The second interface may be configured as an accessory interface for connecting, e.g. wirelessly connecting, the monitor device to one or more accessory devices. The second interface may comprise an antenna and a wireless transceiver, e.g. configured for wireless communication at frequencies in the range from 2.4 to 2.5 GHz. The wireless transceiver may be a Bluetooth transceiver, i.e. the wireless transceiver may be configured for wireless communication according to Bluetooth protocol, e.g. Bluetooth Low Energy,

Bluetooth 4.0, Bluetooth 5. The second interface optionally comprises a loudspeaker and/or a haptic feedback element for provision of an audio signal and/or haptic feedback to the user, respectively.

In one or more exemplary ostomy systems, the monitor device forms an integrated part of the ostomy appliance, e.g. the monitor device may form an integrated part of a base plate
5 and/or the sensor assembly part of the ostomy appliance.

The ostomy system may comprise a docking station forming an accessory device of the ostomy system. The docking station may be configured to electrically and/or mechanically couple the monitor device to the docking station.

10 The docking station may comprise a docking monitor interface. The docking monitor interface may be configured for electrically and/or mechanically connecting the monitor device to the docking station. The docking monitor interface may be configured for wirelessly connecting the monitor device to the docking station. The docking monitor interface of the docking station may be configured to electrically and/or mechanically
15 couple the docking station and the monitor device.

The docking monitor interface of the docking station may comprise, e.g. as part of a first connector of the docking monitor interface, a coupling part for forming a mechanical connection, such as a releasable coupling between the monitor device and the docking station. The coupling part may be configured to engage with a coupling part of the monitor
20 device for releasably coupling the monitor device to the docking station.

The docking monitor interface of the docking station may comprise, e.g. as part of a first connector of the docking monitor interface, a plurality of terminals, such as two, three, four, five, six, seven or more terminals, for forming electrical connections with respective terminals of the monitor device. The docking monitor interface may comprise a ground
25 terminal. The docking monitor interface may comprise a first terminal and/or a second terminal. The docking station may comprise a third terminal. The docking monitor interface may comprise a fourth terminal and/or a fifth terminal. The docking monitor interface optionally comprises a sixth terminal.

Disclosed is a base plate for an ostomy appliance, such as a base plate as described
30 above. Also, a sensor assembly part for an ostomy appliance is disclosed, such as a

sensor assembly part for being applied to a base plate. The base plate and/or the sensor assembly part may comprise: a top layer, a first adhesive layer, an electrode assembly comprising a plurality of electrodes; and a monitor interface configured for connecting the base plate and/or the sensor assembly part to a monitor device, such as mechanically
5 connecting and/or electrically connecting the base plate and/or the sensor assembly part to a monitor device. The base plate and/or the sensor assembly part may comprise additional layers and/or features as described above.

The electrode assembly may have a first part and a second part. The first part may comprise connection parts of the plurality of electrodes, e.g. configured for connecting the
10 plurality of electrodes to terminals of a monitor device. The second part may comprise sensing parts of the plurality of electrodes. The electrode assembly, such as the second part of the electrode assembly, may be arranged between the first adhesive layer and the top layer.

The monitor interface may comprise a plurality of terminals electrically connected to the
15 plurality of electrodes and configured to connect with respective terminals of the monitor device. The connection parts may form the plurality of terminals of the monitor interface.

The top layer may comprise a top layer opening, e.g. configured to allow for connection, such as electrical connection, between the plurality of electrodes of the electrode assembly and terminals of the monitor device.

20 Also disclosed is a device for connecting to a base plate and/or a sensor assembly part of an ostomy appliance, such as the above disclosed base plate. The device may be a monitor device, e.g. such as a monitor device as disclosed above. The monitor device may be configured to measure electrical parameters using electrodes of the base plate and/or sensor assembly part. The device may comprise electronic circuitry. The electronic
25 circuitry may include a processor. The electronic circuitry may be enclosed by the device housing.

The device may comprise an appliance interface, e.g. configured for connecting the device to the base plate and/or the sensor assembly part. The appliance interface may comprise a plurality of terminals, e.g. for forming electrical connection with a plurality of
30 electrodes of the base plate and/or the sensor assembly part. The appliance interface

may comprise a device coupling part. The device coupling part may provide for coupling between the device and the base plate.

Also disclosed is a method for manufacturing a base plate or a sensor assembly part, such as a base plate or a sensor assembly part for an ostomy appliance, such as the
5 base plate or the sensor assembly part as disclosed above.

The method may comprise: providing a top layer; providing an electrode assembly comprising a plurality of electrodes; and providing a first adhesive layer.

The electrode assembly may have a first part and a second part. The first part may comprise connection parts of the plurality of electrodes, e.g. configured for connecting the
10 plurality of electrodes to terminals of a monitor device. The second part may comprise sensing parts of the plurality of electrodes.

The method may further comprise assembling the top layer, the electrode assembly and the first adhesive layer, e.g. such that the electrode assembly, such as the second part of the electrode assembly, is arranged between the first adhesive layer and the top layer.

15 The method may further comprise providing a top layer opening in the top layer. The top layer opening may be configured to allow for connection, such as electrical connection, between the plurality of electrodes of the electrode assembly and terminals of the monitor device.

By providing the top layer opening in the top layer, the electrodes of the electrode
20 assembly may be accessible for connecting the monitor device being exterior to the base plate and/or the sensor assembly part, to the electrode assembly. For example, a plurality of terminals of the monitor device may be connectable through the top layer opening to the plurality of electrodes of the electrode assembly, such as to the connecting parts and/or terminals of the electrode assembly.

25 The top layer, the electrode assembly and/or the first adhesive layer may be substantially planar. The top layer, the electrode assembly and/or the first adhesive layer may extend in a base plate plane and/or in a sensor assembly part plane.

A release liner may be provided on the proximal side of the first adhesive layer. The first adhesive layer may be provided with a release liner on the proximal side of the first

adhesive layer. The release liner may have a distal side facing the first adhesive layer. The first adhesive layer may be provided, such as formed, on the release liner, such as on a distal side of the release liner, e.g. by scraping a thin layer of a first composition, such as a first adhesive composition, onto the release liner to form the first adhesive layer. The
5 first adhesive layer may be formed on the release liner prior to assembling the top layer, the electrode assembly and the first adhesive layer.

The electrode assembly, such as the second part of the electrode assembly, may be provided between the top layer and the first adhesive layer. The electrode assembly may comprise proximal side and/or a distal side. A distal side of the electrode assembly may
10 be facing the top layer. A proximal side of the electrode assembly may be facing the first adhesive layer.

The first part of the electrode assembly may extend through the top layer opening. The first part of the electrode assembly may have two substantially parallel sides, e.g. in the base plate plane and/or in the sensor assembly part plane.

15 The plurality of electrodes may be provided and/or arranged on a proximal side of the electrode assembly. The electrode assembly may comprise a support layer. The plurality of electrodes may be provided and/or arranged on the proximal side of the support layer. For example, the plurality of electrodes may be printed on the proximal side of the support layer. The plurality of electrodes may face the first adhesive layer. The plurality of
20 electrodes may contact the first adhesive layer.

The first part of the electrode assembly may have a primary side. The first part of the electrode assembly may have a secondary side. The primary side of the first part of the electrode assembly may be a proximal side of the first part of the electrode assembly. The secondary side of the first part of the electrode assembly may be a distal side of the first
25 part of the electrode assembly. The primary side of the first part of the electrode assembly may initially be a proximal side of the first part of the electrode assembly. The secondary side of the first part of the electrode assembly may initially be a distal side of the first part of the electrode assembly. The first part of the electrode assembly may be turned over, e.g. to expose the connection parts of the plurality of electrodes on a distal side of the
30 base plate and/or the sensor assembly part. For example, the first part may be bend, e.g. between 170-190 degrees, such as 180 degrees, e.g. for the primary side of the first part of the electrode assembly to face distally. Thus, the primary side of the first part of the

electrode assembly may, at least partly, be facing distally. The first part of the electrode assembly may be turned over through the top layer opening. Turning over the first part of the electrode assembly may be of particular relevance when the plurality of electrodes is provided on the proximal side of the electrode assembly.

- 5 The connection parts of each of the plurality of electrodes may extend from the proximal side of the electrode assembly to the distal side of the electrode assembly, such as through the support layer of the electrode assembly. For example, the support layer may be provided with small holes at the first part of the electrode assembly to allow connection with the connection parts at the distal side of the electrode assembly.
- 10 The monitor interface may comprise a coupling part configured for forming a mechanical connection, such as a releasable coupling, between the monitor device and the base plate and/or the sensor assembly part. For example, the coupling part may be a rigid coupling part. The coupling part may allow for an electrical connection between the monitor device being coupled to the coupling part and the plurality of electrodes of the electrode
- 15 assembly, such as through the plurality of terminals of the monitor interface and the monitor device.

The coupling part may be attached to the top layer, such as a distal side of the top layer. Alternatively or additionally, the coupling part may be attached to the electrode assembly, such as to a distal side of the electrode assembly, such as to a distal side of the support

20 layer of the electrode assembly. The coupling part may be attached to the top layer and/or the electrode assembly by gluing or welding. The coupling part may extend through the top layer opening.

The coupling part may be aligned with the connection parts of the plurality of electrodes. The first part of the electrode assembly may extend into the coupling part. The coupling

25 part may be positioned to cover the connection parts of the plurality of electrodes. Alternatively or additionally, the connection part of the plurality of electrodes may be positioned within a terminal interface region defined by the coupling part. The terminal interface region may be a region wherein terminals, e.g. of the base plate and/or sensor assembly part, may connect, such as mechanically and/or electrically connect, with

30 respective terminals of a monitor device. The terminal interface region need not be a structurally delimited and/or visible region. The terminal interface region may be a region adjacent to the coupling part. Alternatively or additionally, The terminal interface region

may be surrounded by the coupling part, such as a region surrounded by the coupling part. The terminal interface region may be within a 20 mm radius of the coupling part, such as within a 10 mm radius of the coupling part, such as within a 5 mm radius of the coupling part, such as within a 1 mm radius of the coupling part. The coupling part may surround the terminal interface region. The coupling part may have one or more outer sides including a first outer side. The terminal interface region may be adjacent an outer side of the coupling part, such as the first outer side.

The electrode assembly may comprise a reinforcement element. The reinforcement element may be forming at least part of the first part of the electrode assembly. The reinforcement element may provide and/or strengthen the first part of the electrode assembly, e.g. to better account for direct contact between the terminals of the monitor device and the attachment parts of the plurality of electrodes. Furthermore, the reinforcement element may facilitate bending of the first part of the electrode assembly, such as to turn the primary side of the first part of the electrode assembly to face distally.

The reinforcement element may comprise a plurality of conductive paths. The plurality of conductive paths may be connected to the plurality of electrodes, e.g. to form the connection parts of the plurality of electrodes. For example, the reinforcement element may be a flex circuit. The plurality of conductive paths may extend along the entire length of the reinforcement element.

The and/or the sensor assembly part may comprise a second adhesive layer, such as the second adhesive layer as previously disclosed. The second adhesive layer may have a proximal side and/or a distal side. The proximal side of the second adhesive layer may be facing the distal side of the electrode assembly. The distal side of the second adhesive layer may be facing the coupling part. The second adhesive layer may be between the top layer and the electrode assembly. The method may comprise providing the second adhesive layer. The method may comprise positioning the second adhesive layer, e.g. with a proximal side facing the distal side of the electrode assembly. The second adhesive layer may be provided, such as formed, on the proximal side of the top layer, e.g. such that the distal side of the second adhesive layer is facing the proximal side of the top layer. The distal side of the second adhesive layer may be facing the proximal side of the top layer. The second adhesive layer may be provided on the top layer by scraping a thin layer of a second composition, such as a second adhesive composition, onto the top layer, such as on the proximal side of the top layer, to form the second adhesive layer.

The second adhesive layer may comprise a second adhesive layer opening, e.g. aligned with the top layer opening. The second adhesive layer opening may be configured to allow for connection, such as electrical connection, between the plurality of electrodes of the electrode assembly and terminals of the monitor device. For example, connection, such as electrical connection, between the plurality of electrodes of the electrode assembly and terminals of the monitor device may be provided through the top layer opening and the second adhesive layer opening.

The second adhesive layer may extend over a larger area in the base plate plane and/or in the sensor assembly part plane than the first adhesive layer. For example, the second adhesive layer may extend over a second area in the base plate plane/sensor assembly plane, e.g. being larger than the first area and/or covering the first area, where the first adhesive layer extends over the first area.

The top layer opening and/or the second adhesive layer opening may be U-shaped. For example, the top layer opening and/or the second adhesive layer opening may be provided by cutting a U-shaped cut in the top layer and/or the second adhesive layer. For example, the top layer opening and/or the second adhesive layer opening may be provided by a U-shaped cut allowing the top layer and/or the second adhesive layer and the electrode assembly below the top layer to be turned, such as for the electrode assembly, such as the first part of the electrode assembly, to extend through the top layer opening and/or for the primary side of the first part of the electrode assembly to face distally.

The top layer opening and/or the second adhesive layer opening may be provided in the top layer and/or second adhesive layer after assembling the top layer, the electrode assembly and the first adhesive layer and optionally the second adhesive layer.

The base plate and/or the sensor assembly part may comprise a back element. The back element may be provided between the first adhesive layer and the electrode assembly and/or the plurality of electrodes of the electrode assembly. The back element may be provided between the first adhesive layer and the first part of the electrode assembly. The back element may facilitate that a part of the electrode assembly, such as the first part of the electrode assembly is not adhering to the first adhesive layer, such as to allow the part, such as the first part, of the electrode assembly to be turned, such as to extend

through the top layer opening. The back element may be used as a stop for cutting of the opening, such as the U-shaped cut.

Alternatively or additionally, the top layer opening and/or the second adhesive layer opening may be provided in the top layer and/or the second adhesive layer before
5 assembling the top layer, the electrode assembly and the first adhesive layer, and optionally the second adhesive layer, such as before assembling the top layer and/or the second adhesive layer with the electrode assembly and/or the first adhesive layer. For example, the top layer opening and/or the second adhesive layer opening may be provided by a cutting or stamping a hole in the top layer and/or second adhesive layer.

10 The top layer opening and the second adhesive layer opening may be provided simultaneously.

The base plate and/or the sensor assembly part may be cut from assembled layers, e.g. comprising the top layer, the electrode assembly and/or the first adhesive layer. The method may comprise cutting out, such as stamping out, the base plate and/or the sensor
15 assembly part from the assembled top layer, electrode assembly and first adhesive layer. The cutting out may provide a contour of the base plate and/or the sensor assembly part. The cutting out may be provided before turning over the first part of the electrode assembly.

The base plate and/or the sensor assembly part may comprise a stomal opening with a
20 center point. For example, the top layer, the second adhesive, the electrode assembly, the first adhesive and/or the release liner may comprise a stomal opening with a center point, e.g. collectively forming the stomal opening with the center point of the base plate and/or the sensor assembly part.

A horizontal axis in the base plate plane and/or the sensor assembly plane may cross the
25 center point, e.g. of the stomal opening. The horizontal axis may be orientated substantially horizontal, e.g. parallel with the ground, when the base plate is worn as intended. An upper half of the base plate may be defined as the part of the base plate in the base plate plane above the horizontal axis when the base plate is worn as intended. A
30 lower half of the base plate may be defined as the part of the base plate in the base plate plane below the horizontal axis when the base plate is worn as intended.

The coupling part and/or the first part of the electrode assembly may be positioned on the upper half of the base plate and/or sensor assembly part. The coupling part and/or the first part of the electrode assembly may be positioned on the upper half of the base plate and/or sensor assembly part within an angular space from the horizontal axis, e.g. with
5 respect to the center point of the base plate, from 45-135 degrees, such as from 45-90 degrees, or from 90-135 degrees. Such positioning of the coupling part and/or the first part of the electrode assembly may provide that a device, such as the monitor device, may be coupled to the coupling part and/or the first part of the electrode assembly with little or no interference with the ostomy bag. Furthermore, it may ease attachment of the
10 device to the base plate.

Fig. 1 illustrates an exemplary ostomy system. The ostomy system 1 comprises an ostomy appliance 2 including a base plate 4. The base plate 4 is adapted to support an ostomy pouch (not shown). Further, the ostomy system 1 comprises a monitor device 6 and an accessory device 8 (mobile telephone). The monitor device 6 is connectable to the
15 base plate 4 via respective first connectors of the monitor device 6 and base plate 4. The monitor device 6 is configured for wireless communication with the accessory device 8. Optionally, the accessory device 8 is configured to communicate with a server device 10 of the ostomy system 1, e.g. via network 12. The server device 10 may be operated and/or controlled by the ostomy appliance manufacturer and/or a service centre. Ostomy
20 data or parameter data based on the ostomy data are obtained from electrodes/sensors of the ostomy appliance 2 with the monitor device 6. The monitor device 6 processes the ostomy data and/or parameter data based on the ostomy data to determine monitor data that are transmitted to the accessory device 8. In the illustrated ostomy system, the accessory device 8 is a mobile phone, however the accessory device 8 may be embodied
25 as another handheld device, such as a tablet device, or a wearable, such as a watch or other wrist-worn electronic device. Accordingly, the monitor device 6 is configured to determine and transmit monitor data to the accessory device 8. The base plate 4 comprises a coupling member 14 in the form of a coupling ring 16 for coupling an ostomy pouch (not shown) to the base plate (two-part ostomy appliance). The base plate has a
30 stoma-receiving opening 18 with a stoma center point. The size and/or shape of the stomal opening 18 is typically adjusted by the user or nurse before application of the ostomy appliance to accommodate the user's stoma.

The ostomy system 1 optionally comprises a docking station 20 forming an accessory device of the ostomy system 1. The docking station 20 comprises a docking monitor

interface including a first connector 22 configured for electrically and/or mechanically connecting the monitor device 6 to the docking station 20. The docking monitor interface may be configured for wirelessly connecting the monitor device to the docking station. The docking station 20 comprises a user interface 24 for receiving user input and/or providing
5 feedback to the user on the operational state of the docking station 20. The user interface 24 may comprise a touch-screen. The user interface 24 may comprise one or more physical buttons and/or one or more visual indicators, such as light emitting diodes,

Fig. 2 is a schematic block diagram of an exemplary monitor device. The monitor device 6 comprises a monitor device housing 100, a processor 101 and one or more interfaces, the
10 one or more interfaces including a first interface 102 (appliance interface) and a second interface 104 (accessory interface). The monitor device 6 comprises a memory 106 for storing ostomy data and/or parameter data based on the ostomy data. The memory 106 is connected to the processor 101 and/or the first interface 102.

The first interface 102 is configured as an appliance interface for electrically and/or
15 mechanically connecting the monitor device 6 to the ostomy appliance, e.g. ostomy appliance 2. The first interface 102 comprises a plurality of terminals for forming electrical connections with respective terminals of the ostomy appliance 2 (base plate 4). The first interface 102 comprises a ground terminal 108, a first terminal 110, a second terminal 112 and a third terminal 114. The first interface 102 optionally comprises a fourth terminal 116
20 and a fifth terminal 118. The first interface 102 of the monitor device 6 comprises a coupling part 120 for forming a mechanical connection, such as a releasable coupling between the monitor device and the base plate. The coupling part 120 and the terminals 108, 110, 112, 114, 116, and 118 of the first interface 102 form (at least part of) a first connector of the monitor device 6.

25 The monitor device 6 comprises a power unit 121 for powering the monitor device and active components thereof, i.e. the power unit 121 is connected to the processor 101, the first interface 102, the second interface 104, and memory 106. The power unit comprises a battery and charging circuitry. The charging circuitry is connected to the battery and terminals of the first interface 102 for charging the battery via terminals of the first
30 interface, e.g. terminals of the first connector.

The second interface 104 of monitor device is configured as an accessory interface for connecting the monitor device 6 to one or more accessory devices such as accessory

device 8. The second interface 104 comprises an antenna 122 and a wireless transceiver 124 configured for wireless communication with accessory device(s). Optionally, the second interface 104 comprises a loudspeaker 126 and/or a haptic feedback element 128 for provision of respective audio signal and/or haptic feedback to the user.

- 5 The monitor device 6 comprises a sensor unit 140 connected to the processor 101. The sensor unit 140 comprises a temperature sensor for feeding temperature data to the processor and a G-sensor or accelerometer for feeding acceleration data to the processor 101.

The processor 101 is configured to apply a processing scheme, and the first interface 102
10 is configured for collecting ostomy data from the base plate coupled to the first interface, the ostomy data comprising first ostomy data from a first electrode pair of the base plate, second ostomy data from a second electrode pair of the base plate, and third ostomy data from a third electrode pair of the base plate. The ostomy data may be stored in the memory 106 and/or processed in the processor 101 in order to obtain parameter data.

- 15 The parameter data may be stored in the memory 106. The processor 101 is configured to apply a processing scheme, wherein to apply a processing scheme comprises obtain first parameter data based on the first ostomy data; obtain second parameter data based on the second ostomy data; obtain third parameter data based on the third ostomy data. In other words, the processor 101 is configured to obtain first, second and third parameter
20 data based on respective first, second and third ostomy data. To apply a processing scheme comprises to determine an operating state of the base plate of the ostomy appliance based on one or more, e.g. all, of the first parameter data, the second parameter data and the third parameter data, wherein the operating state is indicative of a degree of radial erosion of the base plate and/or acute leakage risk for the ostomy
25 appliance. The monitor device 6 is configured to, in accordance with a determination that the operating state is a first operating state, transmit a first monitor signal comprising monitor data indicative of the first operating state of the base plate via the second interface; and in accordance with a determination that the operating state is a second operating state, transmit a second monitor signal comprising monitor data indicative of the
30 second operating state of the base plate via the second interface.

Fig. 3 illustrates an exploded view of an exemplary base plate of an ostomy appliance. The base plate 4 comprises a first adhesive layer 200. During use, a proximal surface of the first adhesive layer 200 adheres to the user's skin in the peristomal area and/or to

additional seals, such as sealing paste, sealing tape and/or sealing ring. The base plate 4 optionally comprises a second adhesive layer 202, also denoted rim adhesive layer. The base plate 4 comprises a plurality of electrodes arranged in an electrode assembly 204. The electrode assembly 204 is arranged between the first adhesive layer 200 and the
5 second adhesive layer 202. The electrode assembly 204 comprises a support layer with electrodes formed on a proximal surface of the support layer. The base plate 4 comprises a release liner 206 that is peeled off by the user prior to applying the base plate 4 on the skin. The base plate 4 comprises a top layer 208 and a coupling ring 209 for coupling an ostomy pouch to the base plate 4. The top layer 208 is a protective layer protecting the
10 second adhesive layer 202 from external strains and stress during use.

The base plate 4 comprises a monitor interface. The monitor interface is configured for electrically and/or mechanically connecting the ostomy appliance (base plate 4) to the monitor device. The monitor interface of the base plate comprises a coupling part 210 for forming a mechanical connection, such as a releasable coupling between the monitor
15 device and the base plate. The coupling part 210 is configured to engage with a coupling part of the monitor device for releasably coupling the monitor device to the base plate 4. Further, the monitor interface of the base plate 4 comprises a plurality of terminal elements respectively forming a plurality of terminals 212 for forming electrical connections with respective terminals of the monitor device. The coupling part 210 and
20 the terminals 212 form a first connector 211 of the base plate 4. The base plate 4 comprises a first intermediate element 213 on the proximal side of the electrode assembly. The first intermediate element 213 is arranged between the terminal elements forming terminals 212 and the first adhesive layer (not shown). The first intermediate element 213 covers the terminal elements forming terminals 212 of the base plate 4 when
25 seen in the axial direction and protects the first adhesive layer from mechanical stress from the terminal elements of the base plate.

As previously described, some parts of the illustrated base plate 4, may be provided as a separate assembly to be applied to an existing base plate, e.g. comprising one or more of the components as described, such as to provide a base plate like the base plate 4 as
30 described. For example, a sensor assembly part 700 may be provided, e.g. comprising the electrode assembly 204, the first connector 211, the first intermediate element 213, the first adhesive layer 200 and the release liner 206. Additionally, the sensor assembly part 700 may also comprise the second adhesive layer 202 and/or the top layer 208. It may be envisioned that the user may provide a hole in layers of the base plate whereto

the sensor assembly part 700 is to be applied, to allow for the first connector 211 of the sensor assembly part 700 to protrude through layers of the base plate whereto the sensor assembly part 700 is applied. Alternatively, the sensor assembly part 700 may be applied to the base plate such that the first connector 211 is positioned outside the periphery of the base plate.

Fig. 4 illustrates an exploded view of an exemplary electrode assembly 204 of a base plate and/or a sensor assembly part. The electrode assembly 204 has a distal side 204A and a proximal side 204B. The electrode assembly comprises a support layer 214 with proximal surface 214B and electrodes 216 including a ground electrode, a first electrode, a second electrode, a third electrode, a fourth electrode, and a fifth electrode, wherein each electrode has a respective connection part 217 for connecting the electrodes 216 to respective terminal elements of the monitor interface. The electrodes 216 are provided, such as formed, on a proximal side 214B of the support layer 214, e.g. the electrodes 216 may be positioned on the proximal side 214B of the support layer. Further, electrode assembly 204 comprises a masking element 218 with proximal surface 218B and configured to insulate electrode parts of electrodes 216 from the first adhesive layer of the base plate and/or the sensor assembly part. The masking element 218 covers or overlap with parts of the electrodes 216 when seen in the axial direction.

Fig. 5 is a proximal view of proximal surfaces of base plate parts of the base plate 4 and/or the sensor assembly part 700 without the first adhesive layer and the release liner. The base plate 4 and/or the sensor assembly part 700 comprises a first intermediate element 213 on the proximal side of the electrode assembly, i.e. between the electrode assembly 204 and the first adhesive layer (not shown). The first intermediate element 213 covers the terminal elements of the base plate 4 when seen in the axial direction and protects the first adhesive layer from mechanical stress from the terminal elements of the base plate and/or the sensor assembly part.

Fig. 6 is a distal view of an exemplary electrode configuration 220 of electrodes 216 of the electrode assembly 204. The electrode assembly 204, such as the electrode configuration 220 of the electrode assembly 204 comprises a ground electrode 222, a first electrode 224, a second electrode 226, a third electrode 228, a fourth electrode 230, and a fifth electrode 232. The ground electrode 222 comprises a ground connection part 222A and the first electrode 224 comprises a first connection part 224A. The second electrode 226 comprises a second connection part 226A and the third electrode 228 comprises a third

connection part 228A. The fourth electrode 230 comprises a fourth connection part 230A and the fifth electrode 232 comprise a fifth connection part 232A.

The fourth electrode 230 comprises fourth sensing parts 230B. The fifth electrode 232 comprises fifth sensing parts 232B.

- 5 The ground electrode 222 comprises a first electrode part 234 for forming a ground for the first electrode 224. The ground electrode 222 comprises a second electrode part 236 for forming a ground for the second electrode 226. The ground electrode 222 comprises a third electrode part 238 for forming a ground for the third electrode 228. The ground electrode 222 comprises a fourth electrode part 240 for forming a ground for the fourth
10 electrode 230 and the fifth electrode 232. The fourth electrode part 240 of the ground electrode 222 comprises ground sensing parts 222B

Fig. 7 is a distal view of an exemplary masking element. The masking element 218 optionally has a plurality of terminal openings including six terminal openings. The plurality of terminal openings comprises a ground terminal opening 242, a first terminal opening
15 244, a second terminal opening 246, a third terminal opening 248, a fourth terminal opening 250, and a fifth terminal opening 252. The terminal openings 242, 244, 246, 248, 250, 252 of the masking element 218 are configured to overlap and/or be aligned with respective connection parts 222A, 224A, 226A, 228A, 230A, 232A of the electrodes of the electrode assembly.

- 20 The masking element 218 has a plurality of sensor point openings. The sensor point openings comprise primary sensor point openings shown within dotted line 254, each primary sensor point opening configured to overlap a part of the ground electrode 222 and/or a part of the fourth electrode 230. The primary sensor point openings 254 comprise, in the illustrated exemplary masking element, five primary first sensor point
25 openings 254A each configured to overlap a part of the ground electrode 222. The primary sensor point openings 254 comprise, in the illustrated exemplary masking element, four primary second sensor point openings 254B each configured to overlap a part of the fourth electrode 230. The sensor point openings comprise secondary sensor point openings shown within dotted line 256, each second sensor point opening
30 configured to overlap a part of the fourth electrode 230 and/or a part of the fifth electrode 232. The secondary sensor point openings 256 comprise, in the illustrated exemplary masking element, five secondary first sensor point openings 256A each configured to

overlap a part of the fifth electrode 232. The secondary sensor point openings 256 comprise, in the illustrated exemplary masking element, four secondary second sensor point openings 256B each configured to overlap a part of the fourth electrode 230. The sensor point openings comprise tertiary sensor point openings shown within dotted line 5 258, each tertiary sensor opening configured to overlap a part of the fifth electrode 232 and/or a part of the ground electrode 222. The tertiary sensor point openings 258 comprise, in the illustrated exemplary masking element, five tertiary first sensor point openings 258A each configured to overlap a part of the fifth electrode 232. The tertiary sensor point openings 258 comprise, in the illustrated exemplary masking element, four 10 tertiary second sensor point openings 258B each configured to overlap a part of the ground electrode 222.

Fig. 8 is a distal view of an exemplary first adhesive layer. The first adhesive layer 200 has a plurality of sensor point openings. The sensor point openings of the first adhesive layer comprise primary sensor point openings shown within dotted line 260, each primary 15 sensor point opening configured to overlap a part of the ground electrode 222 and/or a part of the fourth electrode 230 of the electrode assembly. The primary sensor point openings 260 comprise, in the illustrated exemplary first adhesive layer, five primary first sensor point openings 260A each configured to overlap a part of the ground electrode 222. The primary sensor point openings 260 comprise, in the illustrated exemplary first 20 adhesive layer, four primary second sensor point openings 260B each configured to overlap a part of the fourth electrode 230. The sensor point openings of the first adhesive layer comprise secondary sensor point openings shown within dotted line 262, each second sensor point opening configured to overlap a part of the fourth electrode 230 and/or a part of the fifth electrode 232 of the electrode assembly. The secondary sensor point openings 262 comprise, in the illustrated exemplary first adhesive layer, five 25 secondary first sensor point openings 262A each configured to overlap a part of the fifth electrode 232. The secondary sensor point openings 262 comprise, in the illustrated exemplary first adhesive layer, four secondary second sensor point openings 262B each configured to overlap a part of the fourth electrode 230. The sensor point openings of the 30 first adhesive layer comprise tertiary sensor point openings shown within dotted line 264, each tertiary sensor opening configured to overlap a part of the fifth electrode 232 and/or a part of the ground electrode 222 of the electrode assembly. The tertiary sensor point openings 264 comprise, in the illustrated exemplary first adhesive layer, five tertiary first sensor point openings 264A each configured to overlap a part of the fifth electrode 232. 35 The tertiary sensor point openings 264 comprise, in the illustrated exemplary first

adhesive layer, four tertiary second sensor point openings 264B each configured to overlap a part of the ground electrode 222. Fig. 9 is a proximal view of the first adhesive layer of Fig. 8.

Fig. 10 is a more detailed distal view of a part of the base plate 4 and/or the sensor assembly part 700. The base plate 4 and/or the sensor assembly part 700 comprises a monitor interface 207. The monitor interface 207 comprises the first connector 211. The first connector 211 comprises coupling part 210 configured to releasably couple the monitor device to the base plate 4 and/or the sensor assembly part 700 and thus forming a releasable coupling. The first connector 211 of the monitor interface 207 comprises a plurality of terminals formed by respective terminal elements for forming respective electrical connections with respective terminals of the monitor device.

The plurality of terminals of the first connector 211 of the monitor interface 207 comprises a ground terminal element 282 forming a ground terminal 282A, a first terminal element 284 forming a first terminal 284, a second terminal element 286 forming a second terminal 286A, and a third terminal element 288 forming a third terminal 288A. The monitor interface 207 optionally comprises a fourth terminal element 290 forming a fourth terminal 290A and/or a fifth terminal element 292 forming a fifth terminal 290. The terminal elements 282, 284, 286, 288, 290, 292 contact respective connection parts 222A, 224A, 226A, 228A, 230a, 232A of electrodes 222, 224, 226, 228, 230, 232.

Fig. 11 illustrates an exploded view of an exemplary base plate 4 of an ostomy appliance. The base plate 4 comprises a first adhesive layer 200. The base plate 4 optionally comprises a second adhesive layer 202, also denoted rim adhesive layer. The base plate 4 comprises a plurality of electrodes 216 arranged in an electrode assembly 204. The electrode assembly 204 is arranged between the first adhesive layer 200 and the second adhesive layer 202. The electrode assembly 204 optionally comprises a support layer 214. The electrodes may be formed on a proximal side of the support layer 214, such as by printing of conductive ink. The electrode assembly 204 optionally comprises a masking element 218, e.g. covering or overlapping with parts of the electrodes 216 when seen in the axial direction, e.g. from a proximal side of the electrodes 216. The electrode assembly has a first part 302 comprising connection parts 217 of the plurality of electrodes 216. The electrode assembly has a second part 303. The base plate 4 comprises a release liner 206. The base plate 4 comprises a top layer 208. The base plate 4 optionally comprises a coupling ring 209 for coupling an ostomy pouch to the base

plate 4. Alternatively, e.g. for a one-part ostomy appliance, a ostomy pouch may be directly fastened to the base plate 4.

The base plate 4 comprises a monitor interface configured for connecting, such as mechanically and/or electronically connecting, the base plate to a monitor device. The monitor interface comprises a plurality of terminals 212 configured to form electrical connections with respective terminals of the monitor device. For example, as illustrated, the connection parts 217 may form the plurality of terminals 212 of the monitor interface. Alternatively, e.g. as shown in Fig. 3, terminal elements may be provided to form the plurality of terminals.

The top layer 208 comprises a top layer opening 304. The second adhesive layer 202 comprises a second adhesive layer opening 306. The top layer opening 304 and the second adhesive layer opening 306 are configured to allow for connection between the plurality of electrodes 216 of the electrode assembly 204 and terminals of a monitor device being coupled to the base plate 4. For example, the first part 302 of the electrode assembly 216 may extend through the top layer opening 304 and the second adhesive layer opening 306.

As described in respect to Fig. 3, some parts of the illustrated base plate 4, may be provided as a separate assembly to be applied to an existing base plate, e.g. comprising one or more of the components as described, such as to provide a base plate like the base plate 4 as described. For example, a sensor assembly part 700 may be provided, e.g. comprising the electrode assembly 204, the first adhesive layer 200 and the release liner 206. Additionally, the sensor assembly part 700 may also comprise the second adhesive layer 202 and/or the top layer 208. It may be envisioned that the user may provide a hole in layers of the base plate whereto the sensor assembly part 700 is to be applied, to allow for connection between the plurality of electrodes 216 of the electrode assembly 204 and terminals of a monitor device being coupled to the base plate 4.

Fig. 12 illustrates an exploded view of an exemplary electrode assembly 204 of a base plate and/or a sensor assembly part, such as the base plate 4 or sensor assembly part 700 of Fig. 11. The electrode assembly 204 has a distal side 204A and a proximal side 204B. The electrode assembly comprises a support layer 214 with a proximal side 214B

and a distal side 214A. The electrode assembly 204 comprises a plurality of electrodes 216. Each electrode of the plurality of electrodes 216 has a respective connection part 217 for connecting the electrodes 216 to respective terminal elements of the monitor interface. The electrodes 216 are provided, such as formed, on the proximal side 214B of the support layer 214, e.g. the electrodes 216 may be positioned on the proximal side 214B of the support layer 214. Further, electrode assembly 204 optionally comprises a masking element 218 with proximal side 218B and configured to insulate electrode parts of electrodes 216 from the first adhesive layer 200 of the base plate 4 and/or the sensor assembly part 700 (see Fig. 11). The masking element 218 covers or overlap with parts of the electrodes 216 when seen in the axial direction, e.g. from the proximal side 204B. The masking element 218 may be configured not to cover or overlap the connecting parts 217 of the plurality of electrodes.

In some exemplary electrode assembly 204, such as the electrode assembly 204 of Fig. 12, the electrode assembly 204 comprises a reinforcement element 308. The reinforcement element 308 may be positioned proximal to the electrode assembly 216, such as proximal to the plurality of electrodes 216, such as proximal to the plurality of connection parts 217 of the plurality of electrodes 216. The reinforcement element 308 may form at least part of a first part of the electrode assembly 204. The reinforcement element 308 may be provided with openings 310 to provide conductive pathways between sides of the reinforcement element 308, such as between a proximal side 308B and a distal side 308A of the reinforcement element 308.

Fig. 13 shows an alternative to Fig. 12, wherein the reinforcement element 308 comprises a plurality of conductive paths 311. For example, the reinforcement element 308 may be a flex circuit. The plurality of conductive paths 311 may be connected to the plurality of electrodes 216. The plurality of conductive paths 311 thereby may form the connection parts 217 of the plurality of electrodes 216. The plurality of conductive paths 311 may provide conductive pathways between the proximal side 308B and the distal side 308A of the reinforcement element 308.

Fig. 14 shows an exemplary electrode configuration 220 of the plurality of electrodes 216, like the electrode configuration 220 as shown in Fig. 6, with the difference that the connection parts 217, such as the ground connection part 222A, the first connection part 224A, the second connection part 226A, the third connection part 228A, the fourth connection part 230A and/or the fifth connection part 232A, are straight connector parts.

Fig. 15, shows a sectional schematic representation of part of a base plate 4 and/or a sensor assembly part 700. The base plate 4 and/or the sensor assembly part 700 comprises a first adhesive layer 200, an optional second adhesive layer 202, and a top layer 208. An electrode assembly comprising a plurality of electrodes 216 is arranged between the first adhesive layer 200 and the top layer 208, such as between the first adhesive layer 200 and the second adhesive layer 202. For example, a second part of the electrode assembly is arranged between the first adhesive layer and the second adhesive layer 202 and/or the top layer 208. The electrode assembly further comprises an optional reinforcement element 308.

10 The top layer 208 and the second adhesive layer 202 comprise openings 304; 306. The top layer 208 comprises a top layer opening 304. The second adhesive layer 202 comprises a second adhesive layer opening 306. A first part 302 of the electrode assembly extends through the top layer opening 304 and the second adhesive layer opening 306. The first part 302 includes the connection parts of the plurality of electrodes and the reinforcement element 308. The first part 302 may include the support layer 214 or a part of the support layer. Connection to the connection parts 217 of the plurality of electrodes may be provided through the reinforcement element 308 and/or through the support layer 214.

Fig. 16, shows a sectional schematic representation of part of a base plate 4 and/or a sensor assembly part 700 as shown in Fig. 15, wherein the base plate 4 and/or the sensor assembly part 700 comprises a coupling part 210. The coupling part 210 is configured for forming a mechanical connection between the monitor device and the base plate 4 and/or the sensor assembly part 700. The first part 302 of the electrode assembly is extending into the coupling part 210, e.g. to allow the monitor device, such as terminals of the monitor device to connect to the electrodes 216 of the base plate 4 and/or the sensor assembly part 700.

In the example shown, the coupling part 210 is attached to the top layer 208. However, in an alternative example, the coupling part 210 is attached to the electrode assembly, in such situation the coupling part 210 may extend through the top layer opening 304 and the second adhesive layer opening 306.

Fig. 17, shows a sectional schematic representation of part of a base plate 4 and/or a sensor assembly part 700. The base plate 4 and/or the sensor assembly part 700

comprises a first adhesive layer 200, an optional second adhesive layer 202, and a top layer 208. An electrode assembly comprising a plurality of electrodes 216 is arranged between the first adhesive layer 200 and the top layer 208, such as between the first adhesive layer 200 and the second adhesive layer 202. For example, a second part of the electrode assembly is arranged between the first adhesive layer and the second adhesive layer 202 and/or the top layer 208.

The top layer 208 comprises a top layer opening 304. The second adhesive layer 202 comprises a second adhesive layer opening 306. The top layer opening 304 and the second adhesive layer opening 306 is provided by a U-shaped cut. A first part 302 of the electrode assembly is turned over, together with a part of the top layer 208 and the second adhesive layer 202 inside the U-shaped cut, to expose the connection parts 217 of the plurality of electrodes 216 on a distal side of the base plate 4 and/or the sensor assembly part 700. The first part 302 includes the connection parts 217 of the plurality of electrodes and extends through the top layer opening 304 and the second adhesive layer opening 306. The monitor device may thereby connect to the plurality of connection parts 217. Although not shown in Fig. 17, the electrode assembly may further comprise an optional reinforcement element 308, e.g. as illustrated in Figs. 15 and 16 and/or the base plate 4 and/or the sensor assembly part 700 may be provided with a coupling part 210, e.g. as shown in Fig. 16.

The base plate 4 and/or the sensor assembly part 700 comprises a back element 312. The back element 312 is provided between the first adhesive layer 200 and the electrode assembly and/or the plurality of electrodes 216 of the electrode assembly, such as between the first adhesive layer 200 and the first part 302 of the electrode assembly. The back element 312 may facilitate that the first part 302 of the electrode assembly is not adhering to the first adhesive layer, such as to allow the first part 302 of the electrode assembly to be turned. A back element 312 may similarly be applied to the exemplary base plates and/or sensor assembly parts as described in relation to Fig. 15 and/or 16.

Fig. 18 shows a flowchart of an exemplary method 1000, such as a method for manufacturing a base plate or a sensor assembly part for an ostomy appliance. The method comprises providing 1002 a top layer, optionally providing 1004 a second adhesive layer, and providing 1006 an electrode assembly comprising a plurality of electrodes, the electrode assembly having a first part and a second part, the first part comprising connection parts of the plurality of electrodes. The method further comprises:

providing 1008 a first adhesive layer, assembling 1010 the top layer, the optional second adhesive layer, the electrode assembly and the first adhesive layer, and providing 1012 a top layer opening in the top layer and optionally a second adhesive layer opening in the second adhesive layer.

- 5 Assembling 1010 the top layer, the optional second adhesive layer, the electrode assembly and the first adhesive layer includes assembling such that the electrode assembly is arranged between the first adhesive layer and the top layer and/or between the first adhesive layer and the optional second adhesive layer. For example, assembling 1010 the top layer, the optional second adhesive layer, the electrode assembly and the
10 first adhesive layer includes assembling such that the second part of the electrode assembly, e.g. comprising sensing parts of the plurality of electrodes, is arranged between the first adhesive layer and the second adhesive layer / the top layer.

- Providing 1012 the top layer opening and the optional second adhesive layer opening comprises providing 1012 the top layer opening and the optional second adhesive layer
15 opening, such that the top layer opening and the optional second adhesive layer opening is configured to allow for connection between the plurality of electrodes of the electrode assembly and terminals of the monitor device.

- The method 1000 furthermore optionally comprises directing 1014 the first part of the electrode assembly through the top layer opening and the optional second adhesive layer
20 opening. Directing 1014 the first part of the electrode assembly through the top layer opening and the optional second adhesive layer may include turning over the first part of the electrode assembly, such as to expose the connection parts of the plurality of electrodes on a distal side of the base plate and/or the sensor assembly part.

- The method 1000 furthermore optionally comprises providing 1016 a coupling part on the
25 base plate and/or the sensor assembly part. The coupling part may be provided 1016 to be aligned with the top layer opening and the optional second adhesive layer opening. The coupling part may be provided 1016 to be aligned with the first part of the electrode assembly.

- As illustrated, the top layer opening and the optional second adhesive layer opening may
30 be provided 1010 after assembling 1008. Alternatively, the top layer opening and the optional second adhesive layer opening may be provided 1010 before assembling 1008.

For example, the top layer opening and the optional second adhesive layer opening may be provided before providing the electrode assembly. The top layer opening and the optional second adhesive layer opening may be provided simultaneously, e.g. by cutting through both the top layer and the second adhesive layer.

- 5 The position of the first connector on the base plate and/or the sensor assembly part, the number of terminals and the position of the terminals in the coupling part may be adapted to the electrode configuration used in the electrode assembly of the base plate and/or the sensor assembly part.

- 10 The use of the terms “first”, “second”, “third” and “fourth”, “primary”, “secondary”, “tertiary” etc. does not imply any particular order but is included to identify individual elements. Moreover, the use of the terms “first”, “second”, “third” and “fourth”, “primary”, “secondary”, “tertiary” etc. does not denote any order or importance, but rather the terms “first”, “second”, “third” and “fourth”, “primary”, “secondary”, “tertiary” etc. are used to distinguish one element from another. Note that the words “first”, “second”, “third” and “fourth”,
15 “primary”, “secondary”, “tertiary” etc. are used here and elsewhere for labelling purposes only and are not intended to denote any specific spatial or temporal ordering. Furthermore, the labelling of a first element does not imply the presence of a second element and vice versa.

- 20 Although particular features have been shown and described, it will be understood that they are not intended to limit the claimed invention, and it will be made obvious to those skilled in the art that various changes and modifications may be made without departing from the spirit and scope of the claimed invention. The specification and drawings are, accordingly to be regarded in an illustrative rather than restrictive sense. The claimed invention is intended to cover all alternatives, modifications and equivalents.

- 25 Exemplary embodiments of the present disclosure are set out in the following items:

1. A base plate for an ostomy appliance, the base plate comprising:
- a top layer;
 - a first adhesive layer; and
 - an electrode assembly comprising a plurality of electrodes, the electrode
30 assembly having a first part and a second part, the first part comprising

connection parts of the plurality of electrodes, the second part being arranged between the first adhesive layer and the top layer;

- a monitor interface configured for connecting the base plate to a monitor device, the monitor interface comprising a plurality of terminals configured to form electrical connections with respective terminals of the monitor device,

wherein the top layer comprises a top layer opening configured to allow for connection between the plurality of electrodes of the electrode assembly and terminals of the monitor device.

10 2. The base plate of item 1, wherein the connection parts form the plurality of terminals of the monitor interface.

3. The base plate of any of items 1 or 2, wherein the first part of the electrode assembly extends through the top layer opening.

15

4. The base plate of item 3, wherein the electrode assembly comprises a proximal side and a distal side, and wherein the plurality of electrodes is arranged on the proximal side, and wherein the first part of the electrode assembly is turned over to expose the connection parts of the plurality of electrodes on a distal side of the base plate.

20

5. The base plate of any of items 1-3, wherein the electrode assembly comprises a proximal side and a distal side, and wherein the plurality of electrodes is arranged on the proximal side, and wherein the connection parts of each of the plurality of electrodes extend from the proximal side of the electrode assembly to the distal side of the electrode assembly, such as through a support layer of the electrode assembly.

25

6. The base plate of any of the preceding items, wherein the top layer opening is U-shaped.

30

7. The base plate of any of the preceding items, wherein the monitor interface comprises a coupling part configured for forming a mechanical connection, such as a releasable coupling, between the monitor device and the base plate.

8. The base plate of item 7, wherein the coupling part is attached to the electrode assembly, such as the distal side of the electrode assembly, and wherein the coupling part extends through the top layer opening.
- 5 9. The base plate of item 7, wherein the coupling part is attached to the top layer, such as the distal side of the top layer.
10. The base plate of any of items 7-9, wherein the first part of the electrode assembly is extending into the coupling part.
- 10 11. The base plate of any of the preceding items, wherein the electrode assembly comprises a reinforcement element, and wherein the reinforcement element is forming at least part of the first part of the electrode assembly.
- 15 12. The base plate of item 11, wherein the reinforcement element comprises a plurality of conductive paths connected to the plurality of electrodes to form the connection parts of the plurality of electrodes.
- 20 13. The base plate of any of items 11 or 12, wherein the reinforcement element is a flex circuit.
14. The base plate of any of the preceding items comprising a second adhesive layer between the top layer and the electrode assembly, and wherein the second adhesive layer comprises a second adhesive layer opening aligned with the top layer opening and
25 configured to allow for electrical connection between the plurality of electrodes of the electrode assembly and terminals of the monitor device.
15. Method for manufacturing a base plate or a sensor assembly part for an ostomy appliance, the method comprising:
- 30
- providing a top layer;
 - providing an electrode assembly comprising a plurality of electrodes, the electrode assembly having a first part and a second part, the first part comprising connection parts of the plurality of electrodes;
 - providing a first adhesive layer; and

- assembling the top layer, the electrode assembly and the first adhesive layer, such that the second part of the electrode assembly is arranged between the first adhesive layer and the top layer,

the method further comprising:

- 5 – providing a top layer opening in the top layer, the top layer opening being configured to allow for connection between the plurality of electrodes of the electrode assembly and terminals of the monitor device.

16. Method according to item 15 wherein the top layer opening is provided in the top layer after assembling the top layer, the electrode assembly and the first adhesive layer.

17. Method according to item 15 wherein the top layer opening is provided in the top layer before assembling the top layer, the electrode assembly and the first adhesive layer.

15 18. Method according to any of items 15-17, wherein the top layer opening is provided by cutting a U-shaped cut in the top layer.

19. A sensor assembly part for an ostomy appliance, the sensor assembly part comprising:

- 20 – a top layer;
- a first adhesive layer; and
- an electrode assembly comprising a plurality of electrodes, the electrode assembly having a first part and a second part, the first part comprising connection parts of the plurality of electrodes, the second part being
- 25 arranged between the first adhesive layer and the top layer;
- a monitor interface configured for connecting the sensor assembly part to a monitor device, the monitor interface comprising a plurality of terminals configured to form electrical connections with respective terminals of the monitor device,

30 wherein the top layer comprises a top layer opening configured to allow for connection between the plurality of electrodes of the electrode assembly and terminals of the monitor device.

20. The sensor assembly part of item 19, wherein the connection parts form the plurality of terminals of the monitor interface.

21. The sensor assembly part of any of items 19 or 20, wherein the first part of the electrode assembly extends through the top layer opening.
- 5 22. The sensor assembly part of item 21, wherein the electrode assembly comprises a proximal side and a distal side, and wherein the plurality of electrodes is arranged on the proximal side, and wherein the first part of the electrode assembly is turned over to expose the connection parts of the plurality of electrodes on a distal side of the sensor assembly part.
- 10 23. The sensor assembly part of any of items 19-21, wherein the electrode assembly comprises a proximal side and a distal side, and wherein the plurality of electrodes is arranged on the proximal side, and wherein the connection parts of each of the plurality of electrodes extend from the proximal side of the electrode assembly to the distal side of
15 the electrode assembly, such as through a support layer of the electrode assembly.
24. The sensor assembly part of any of items 19-23, wherein the top layer opening is U-shaped.
- 20 25. The sensor assembly part of any of items 19-24, wherein the monitor interface comprises a coupling part configured for forming a mechanical connection, such as a releasable coupling, between the monitor device and the sensor assembly part.
- 25 26. The sensor assembly part of item 25, wherein the coupling part is attached to the electrode assembly, such as the distal side of the electrode assembly, and wherein the coupling part extends through the top layer opening.
27. The sensor assembly part of item 25, wherein the coupling part is attached to the top layer, such as the distal side of the top layer.
- 30 28. The sensor assembly part of any of items 25-27, wherein the first part of the electrode assembly is extending into the coupling part.
- 35 29. The sensor assembly part of any of items 19-28, wherein the electrode assembly comprises a reinforcement element, and wherein the reinforcement element is forming at least part of the first part of the electrode assembly.

30. The sensor assembly part of item 29, wherein the reinforcement element comprises a plurality of conductive paths connected to the plurality of electrodes to form the connection parts of the plurality of electrodes.

5

31. The sensor assembly part of any of items 29 or 30, wherein the reinforcement element is a flex circuit.

32. The sensor assembly part of any of items 19-31 comprising a second adhesive
10 layer between the top layer and the electrode assembly, and wherein the second adhesive layer comprises a second adhesive layer opening aligned with the top layer opening and configured to allow for electrical connection between the plurality of electrodes of the electrode assembly and terminals of the monitor device.

15

LIST OF REFERENCES

- 1 ostomy system
- 2 ostomy appliance
- 4 base plate
- 5 6 monitor device
- 8 accessory device
- 10 server device
- 12 network
- 14 coupling member
- 10 16 coupling ring
- 18 stoma-receiving opening

- 100 monitor device housing
- 101 processor
- 15 102 first interface
- 104 second interface
- 106 memory
- 108 ground terminal of monitor device
- 110 first terminal of monitor device
- 20 112 second terminal of monitor device
- 114 third terminal of monitor device
- 116 fourth terminal of monitor device
- 118 fifth terminal of monitor device
- 120 coupling part
- 25 122 antenna
- 124 wireless transceiver
- 126 loudspeaker
- 128 haptic feedback element

- 30 200 first adhesive layer
- 200A distal side/surface of first adhesive layer
- 200B proximal side/surface of first adhesive layer
- 202 second adhesive layer
- 202A distal side/surface of second adhesive layer
- 35 202B proximal side/surface of second adhesive layer
- 204 electrode assembly

- 204A distal side/surface of electrode assembly
- 204B proximal side/surface of electrode assembly
- 206 release liner
- 206A distal side/surface of the release liner
- 5 206B proximal side/surface of the release liner
- 207 monitor interface
- 208 top layer
- 208A distal side/surface of the top layer
- 208B proximal side/surface of the top layer
- 10 209 coupling ring
- 210 coupling part of first connector
- 211 first connector
- 212 terminals of first connector
- 213 first intermediate element
- 15 213A distal side/surface of first intermediate element
- 213B proximal side/surface of first intermediate element
- 214 support layer of electrode assembly
- 214A distal side/surface of support layer
- 214B proximal side/surface of support layer
- 20 216 electrodes of electrode assembly
- 217 connection parts
- 218 masking element
- 218A distal side/surface of masking element
- 218B proximal side/surface of masking element
- 25 220 electrode configuration
- 222 ground electrode
- 222A ground connection part
- 222B ground sensing part
- 224 first electrode
- 30 224A first connection part
- 226 second electrode
- 226A second connection part
- 228 third electrode
- 228A third connection part
- 35 230 fourth electrode
- 230A fourth connection part

- 230B fourth sensing part
- 232 fifth electrode
- 232A fifth connection part
- 232B fifth sensing part
- 5 234 first electrode part of the ground electrode
- 236 second electrode part of the ground electrode
- 238 third electrode part of the ground electrode
- 240 fourth electrode part of the ground electrode
- 242 ground terminal opening
- 10 244 first terminal opening
- 246 second terminal opening
- 248 third terminal opening
- 250 fourth terminal opening
- 252 fifth terminal opening
- 15 254 primary sensor point openings of masking element
- 254A primary first sensor point opening
- 254B primary second sensor point opening
- 256 secondary sensor point openings of masking element
- 256A secondary first sensor point opening
- 20 256B secondary second sensor point opening
- 258 tertiary sensor point openings of masking element
- 258A tertiary first sensor point opening
- 258B tertiary second sensor point opening
- 260 primary sensor point openings of first adhesive layer
- 25 260A primary first sensor point opening
- 260B primary second sensor point opening
- 262 secondary sensor point openings of first adhesive layer
- 262A secondary first sensor point opening
- 262B secondary second sensor point opening
- 30 264 tertiary sensor point openings of first adhesive layer
- 264A tertiary first sensor point opening
- 264B tertiary second sensor point opening
- 270 terminal interface region
- 272 terminal element(s)
- 35 272A distal end of terminal element(s)
- 272B proximal end of terminal element(s)

- 274A distal part of terminal element(s)
- 274B proximal part of terminal element(s)
- 276A distal terminal element bend
- 276B proximal terminal element bend
- 5 278 guide hole
- 282 ground terminal element
- 282A ground terminal
- 284 first terminal element
- 284A first terminal
- 10 286 second terminal element
- 286A second terminal
- 288 third terminal element
- 288A third terminal
- 290 fourth terminal element
- 15 290A fourth terminal
- 292 fifth terminal element
- 292A fifth terminal
- 302 first part of electrode assembly
- 303 second part of electrode assembly
- 20 304 top layer opening
- 306 second adhesive layer opening
- 308 reinforcement element
- 308A distal side of reinforcement element
- 308B proximal side of reinforcement element
- 25 310 openings
- 311 conductive paths
- 312 back element
- 700 sensor assembly part
- 1000 method
- 30 1002 providing top layer
- 1004 providing second adhesive layer
- 1006 providing electrode assembly
- 1008 providing first adhesive layer
- 1010 assembling layers
- 35 1012 providing layer opening(s)
- 1014 directing part of electrode assembly

1016 providing coupling part

M number of terminals in the first interface of the monitor device

Claims

1. Method for manufacturing a base plate for an ostomy appliance, the method comprising:

- providing a top layer;
- providing an electrode assembly comprising a plurality of electrodes, the electrode assembly having a first part and a second part, the first part comprising connection parts of the plurality of electrodes configured for connecting the plurality of electrodes to terminals of a monitor device; the electrode assembly comprises a support layer,
- providing and/or arranging the plurality of electrodes on the proximal side of the support layer
- providing a first adhesive layer comprising one or more water soluble or water swellable hydrocolloids; and
- assembling the top layer, the electrode assembly and the first adhesive layer, such that the second part of the electrode assembly is arranged between the first adhesive layer and the top layer,

the method further comprising:

- providing a top layer opening in the top layer, the top layer opening being configured to allow for connection between the connection parts of the plurality of electrodes and terminals of the monitor device.

2. Method according to claim 1, wherein the top layer comprises a top layer stomal opening and the first adhesive layer comprises a first adhesive stomal opening, and wherein assembling the top layer, the electrode assembly and the first adhesive layer comprises aligning the top layer stomal opening and the first adhesive stomal opening to form a stomal opening of the base plate configured to allow passage of output from a stoma of a user.

3. Method according to any of claims 1-2 wherein the top layer opening is provided in the top layer after assembling the top layer, the electrode assembly and the first adhesive layer.

4. Method according to any of claims 1-2 wherein the top layer opening is provided in the top layer before assembling the top layer, the electrode assembly and the first adhesive layer.

5. Method according to any of claims 1-4, wherein the top layer opening is provided by cutting a U-shaped cut in the top layer.

- 5 6. A base plate for an ostomy appliance, the base plate comprising:
- a top layer;
 - a first adhesive layer comprising one or more water soluble or water swellable hydrocolloids; and
 - an electrode assembly comprising a plurality of electrodes, the electrode assembly having a first part and a second part, the first part comprising connection parts of the plurality of electrodes configured for connecting the plurality of electrodes to terminals of a monitor device, the second part being arranged between the first adhesive layer and the top layer;
- 10 The electrode assembly comprises a support layer, the plurality of electrodes being provided and/or arranged on the proximal side of the support layer;
- 15 a monitor interface configured for connecting the base plate to a monitor device, the monitor interface comprising a plurality of terminals configured to form electrical connections with respective terminals of the monitor device,
- 20

wherein the top layer comprises a top layer opening configured to allow for connection between the plurality of electrodes of the electrode assembly and terminals of the monitor device.

- 25 7. Base plate according to claim 6, wherein the plurality of electrodes is printed on the proximal side of the support layer.

8. Base plate according to claim 6 comprising a stomal opening at least partly formed by a top layer stomal opening of the top layer and a first adhesive stomal opening of the first adhesive layer, the stomal opening of the base plate being configured to allow
- 30 passage of output from a stoma of a user.

9. The base plate of any of claims 6-8, wherein the connection parts form the plurality of terminals of the monitor interface.

10. The base plate of any of claims 6-9, wherein the first part of the electrode assembly extends through the top layer opening.

5 11. The base plate of claim 10, wherein the electrode assembly comprises a proximal side and a distal side, and wherein the plurality of electrodes is arranged on the proximal side, and wherein the first part of the electrode assembly is turned over to expose the connection parts of the plurality of electrodes on a distal side of the base plate.

10 12. The base plate of any of claims 6-10, wherein the electrode assembly comprises a proximal side and a distal side, and wherein the plurality of electrodes is arranged on the proximal side, and wherein the connection parts of each of the plurality of electrodes extend from the proximal side of the electrode assembly to the distal side of the electrode assembly, such as through a support layer of the electrode assembly.

15 13. The base plate of any of claims 6-12, wherein the top layer opening is U-shaped.

14. The base plate of any of claims 6-13, wherein the monitor interface comprises a coupling part configured for forming a mechanical connection, such as a releasable coupling, between the monitor device and the base plate.

20 15. The base plate of claim 14, wherein the coupling part is attached to the electrode assembly, such as the distal side of the electrode assembly, and wherein the coupling part extends through the top layer opening.

25 16. The base plate of claim 14, wherein the coupling part is attached to the top layer, such as the distal side of the top layer.

17. The base plate of any of claims 12-14, wherein the first part of the electrode assembly is extending into the coupling part.

30 18. The base plate of any of claims 6-17, wherein the electrode assembly comprises a reinforcement element, and wherein the reinforcement element is forming at least part of the first part of the electrode assembly.

19. The base plate of claim 18, wherein the reinforcement element comprises a plurality of conductive paths connected to the plurality of electrodes to form the connection parts of the plurality of electrodes.

5 20. The base plate of any of claims 18 or 19, wherein the reinforcement element is a flex circuit.

10 21. The base plate of any of claims 6-20 comprising a second adhesive layer between the top layer and the electrode assembly, and wherein the second adhesive layer comprises a second adhesive layer opening aligned with the top layer opening and configured to allow for electrical connection between the plurality of electrodes of the electrode assembly and terminals of the monitor device, the second adhesive layer comprising one or more water soluble or water swellable hydrocolloids.

15 22. A base plate for an ostomy appliance obtainable by the method according to any of claims 1-5.

1/15

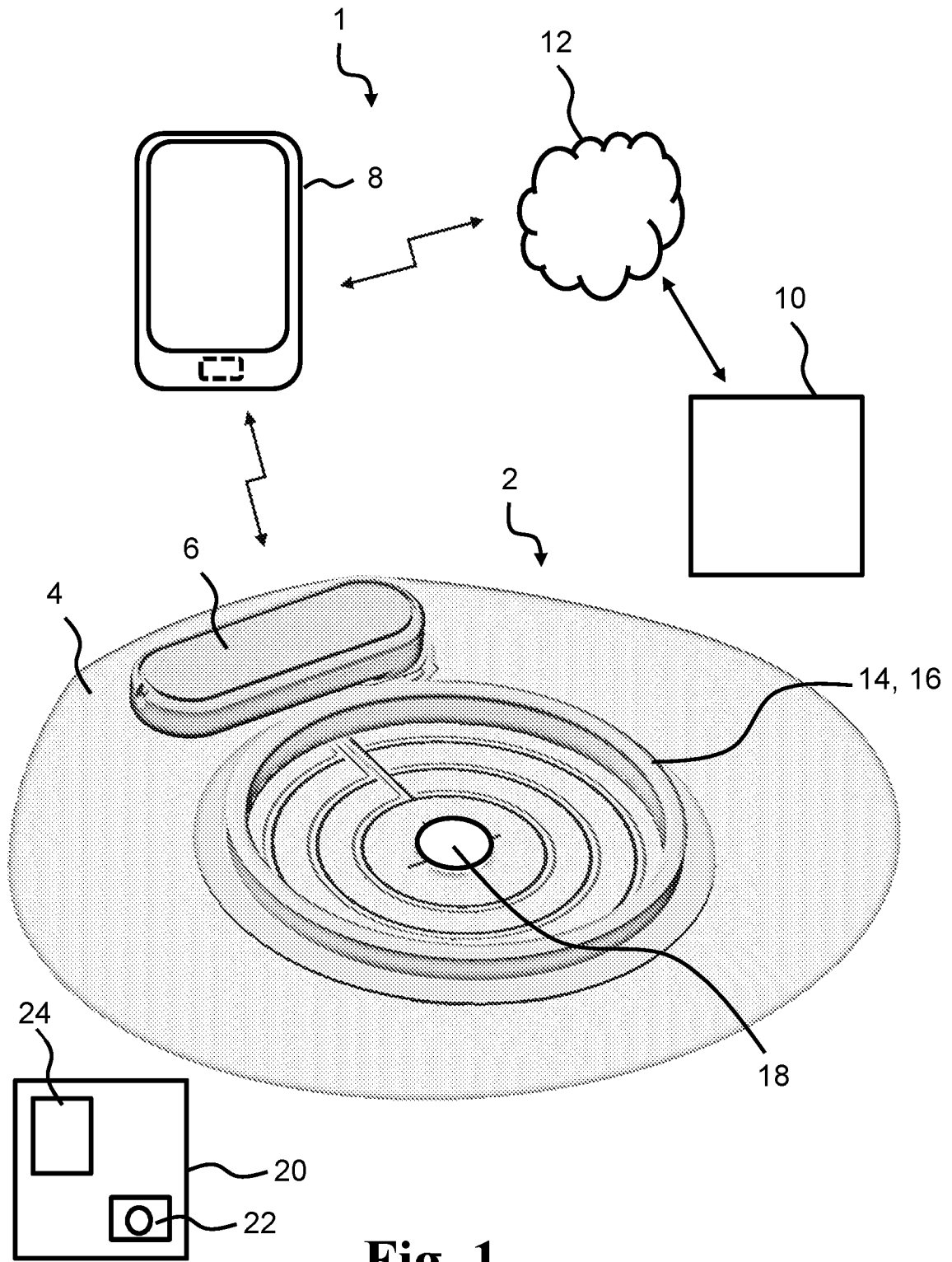

Fig. 1

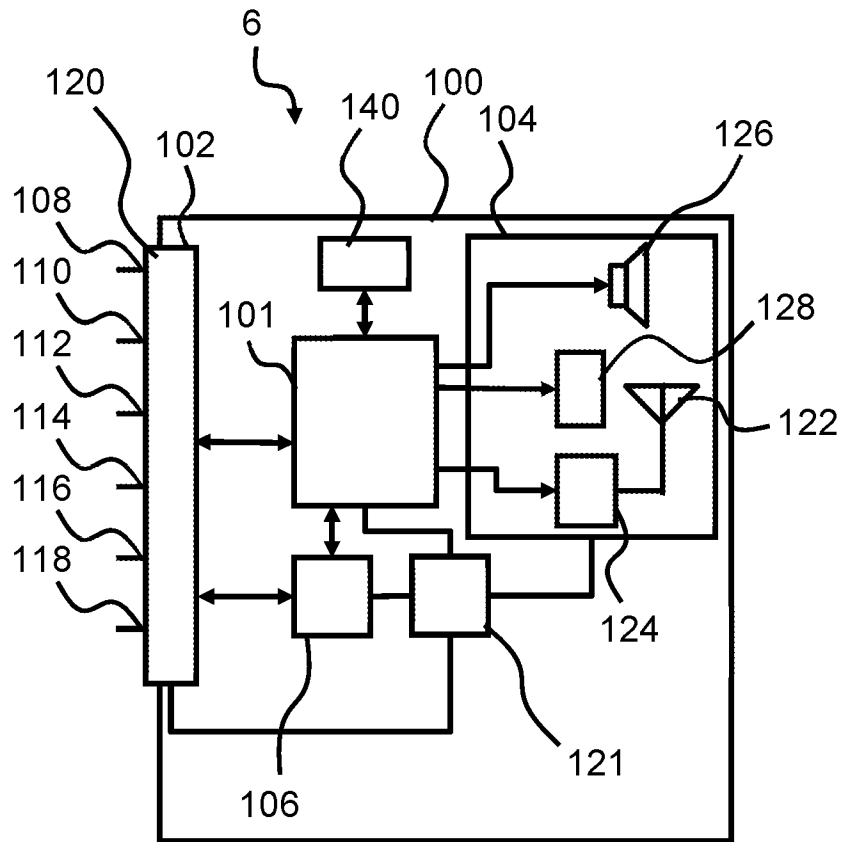

Fig. 2

3/15

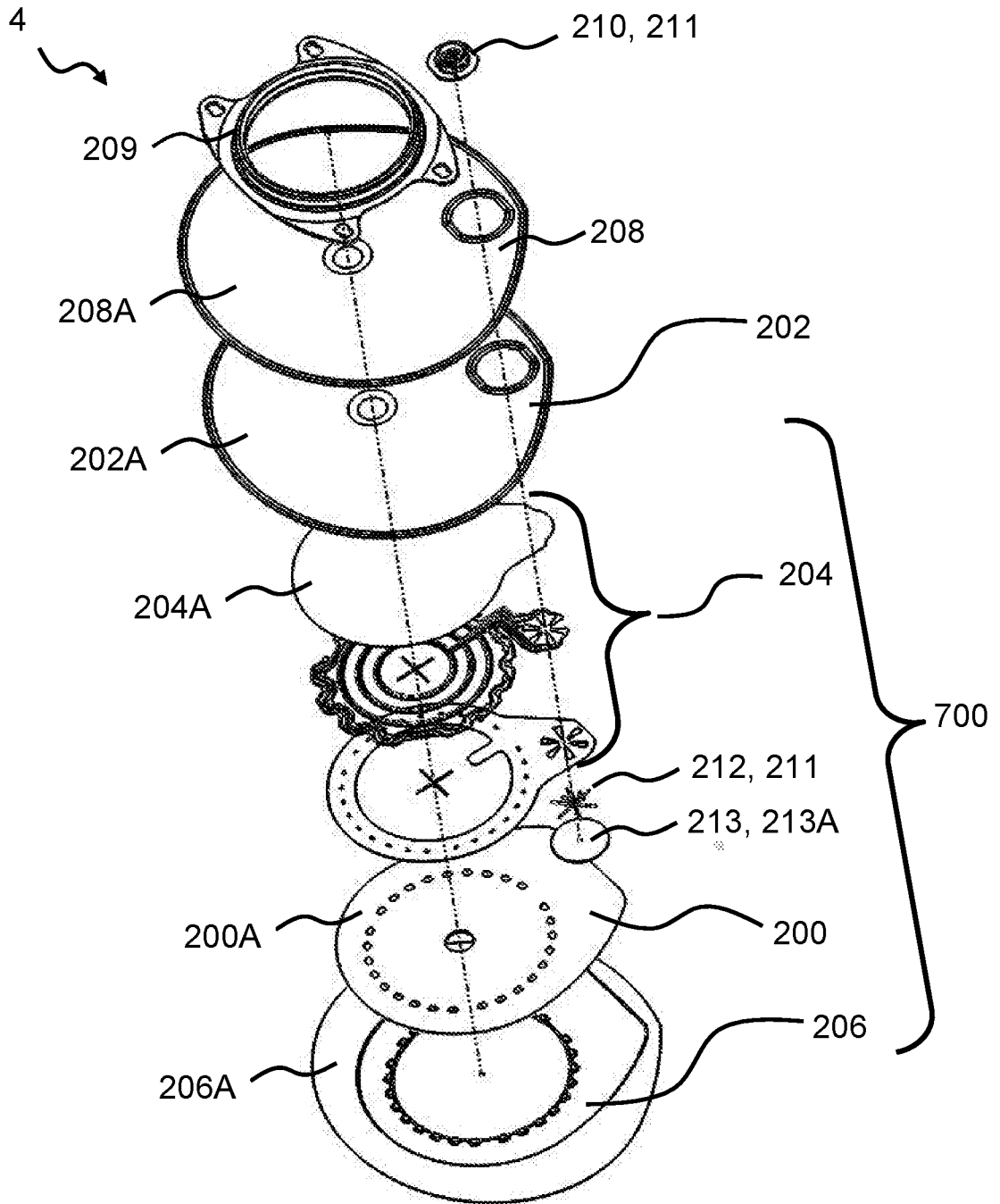

Fig. 3

4/15

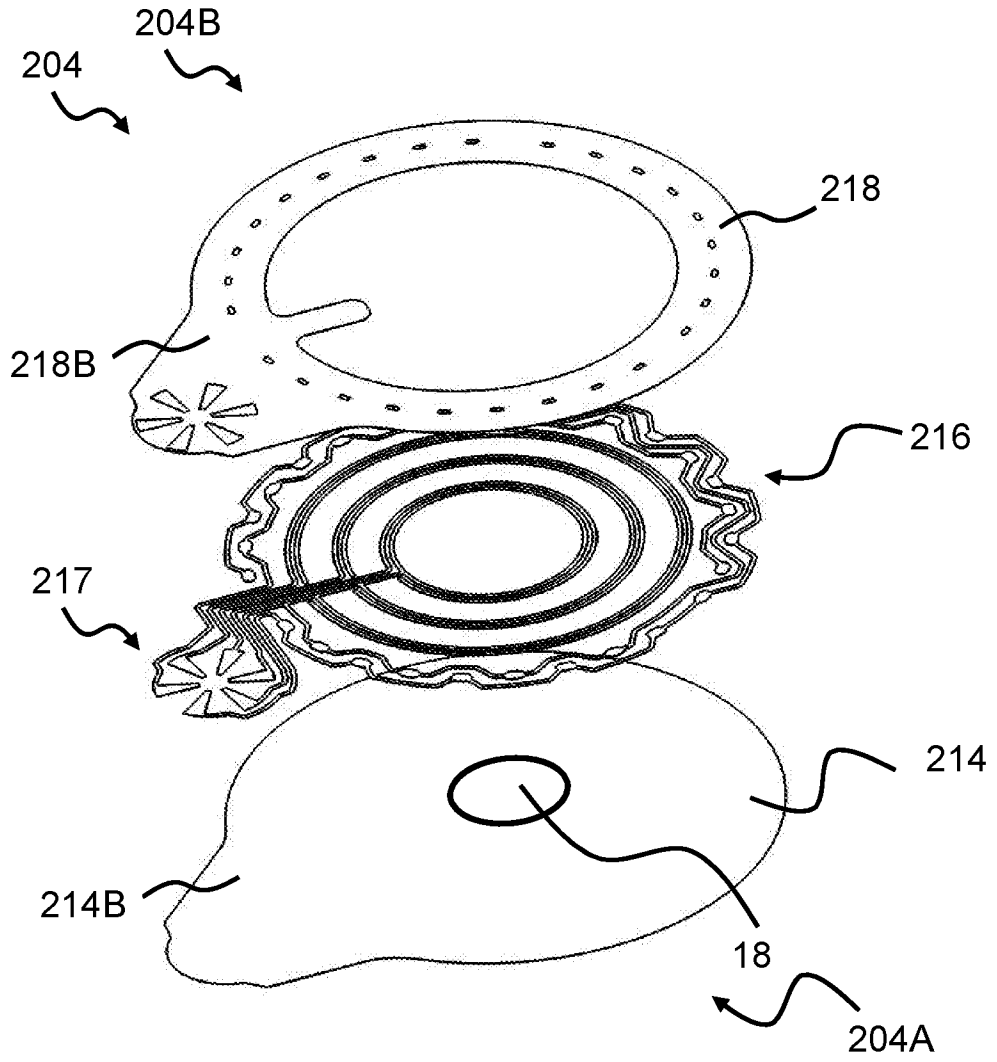

Fig. 4

5/15

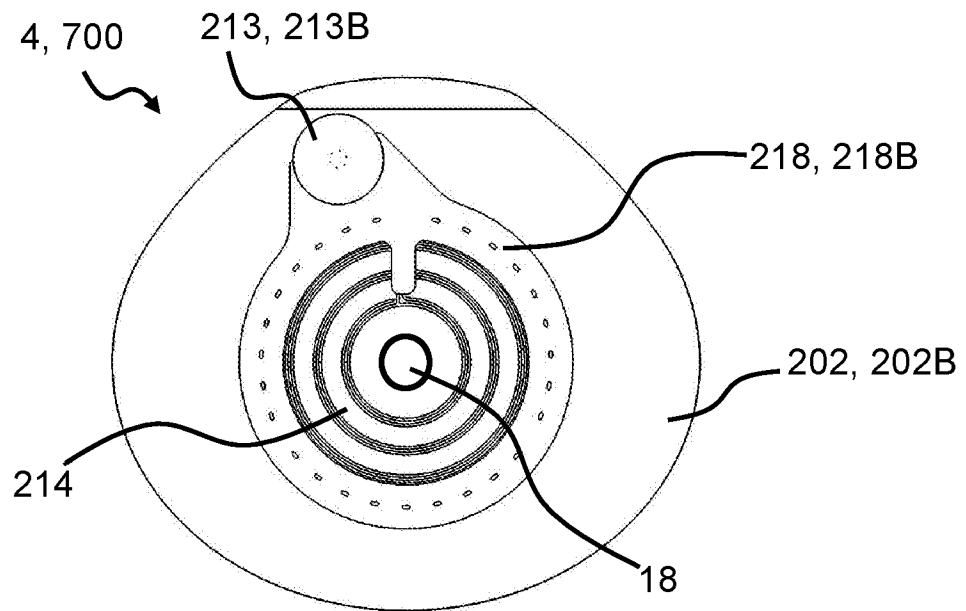

Fig. 5

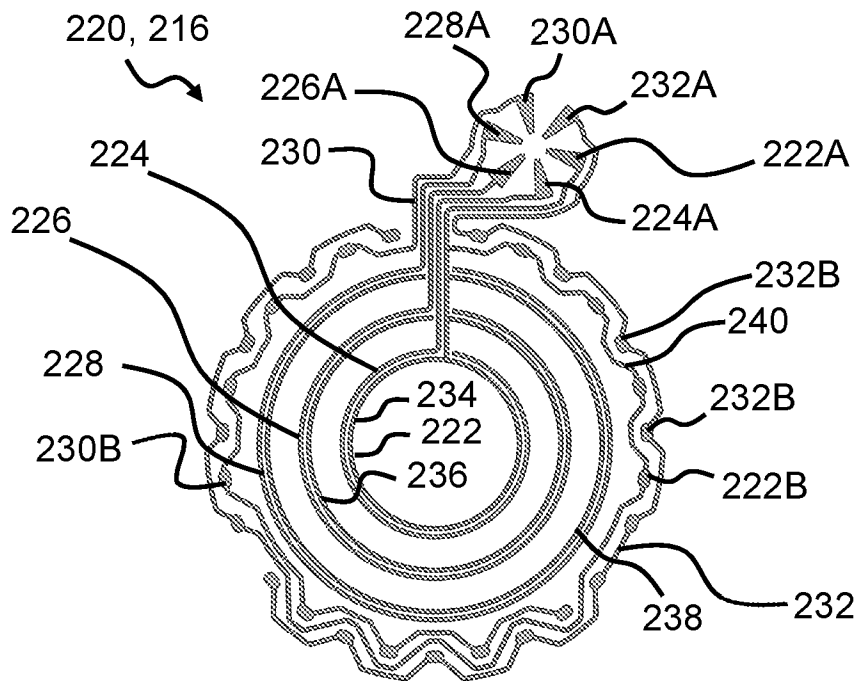

Fig. 6

6/15

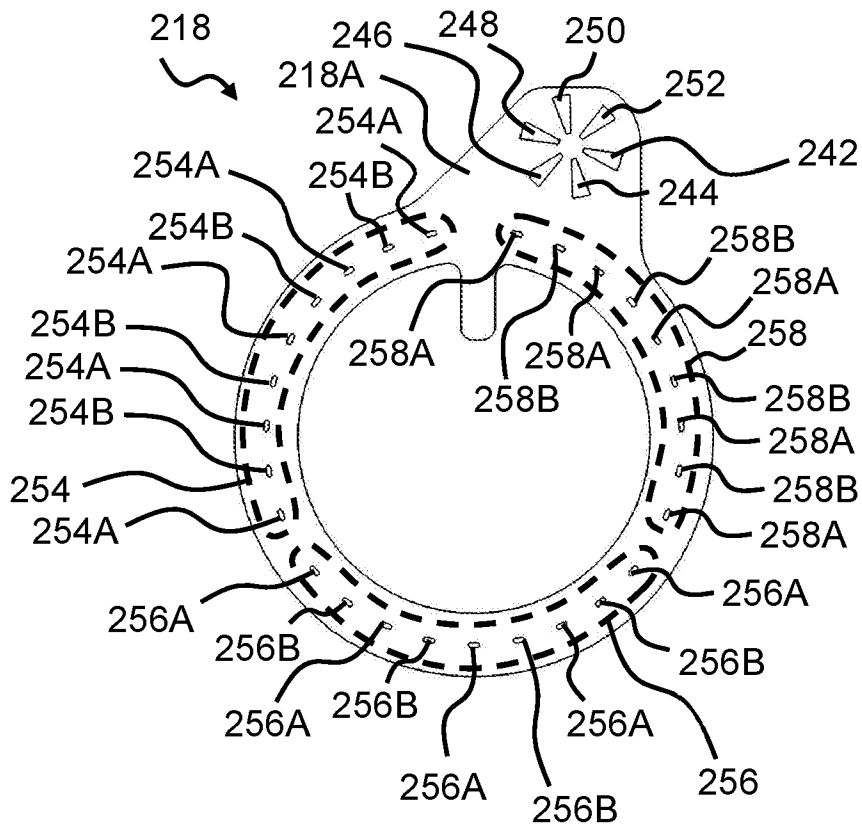

Fig. 7

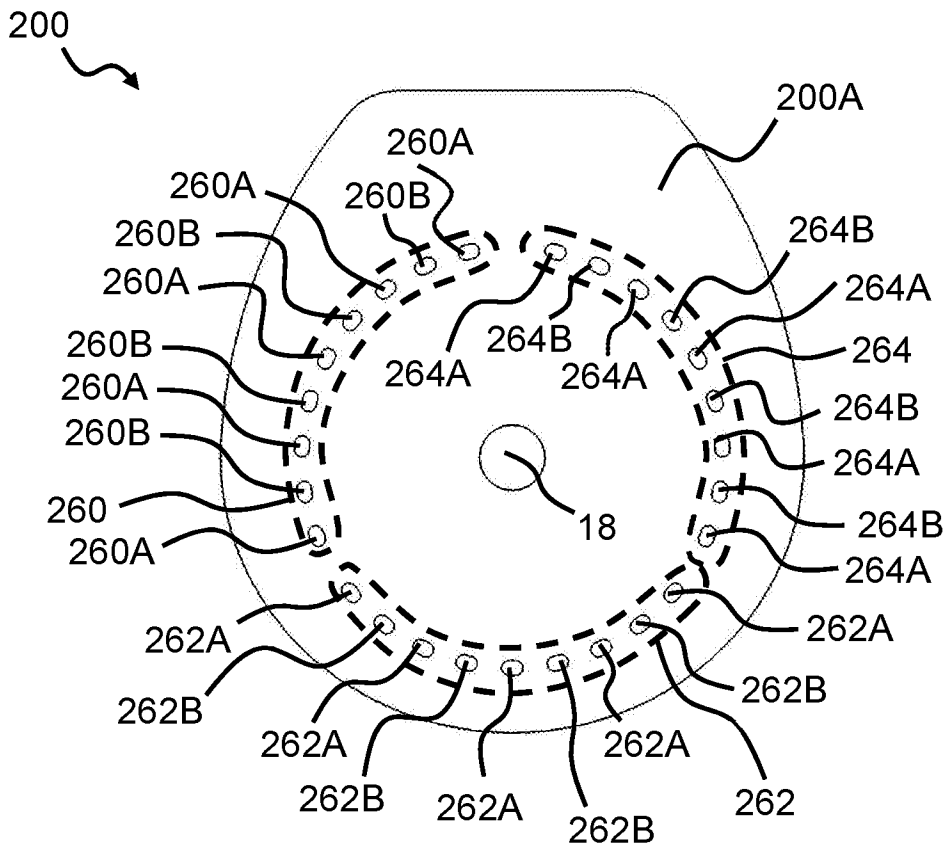

Fig. 8

8/15

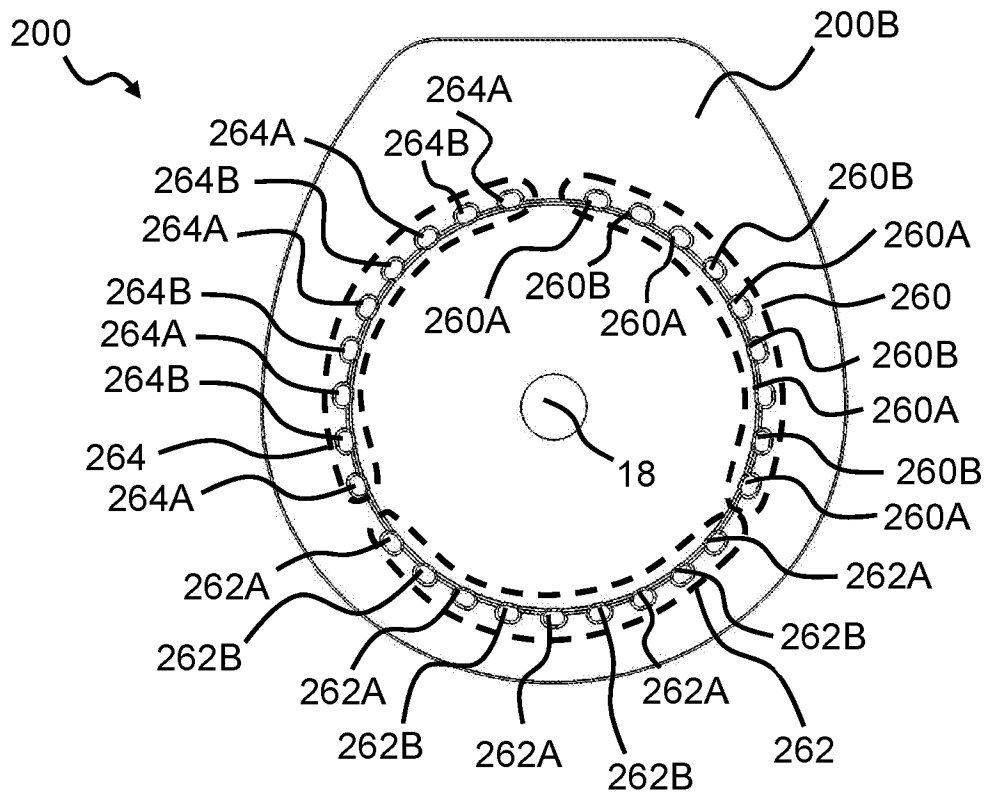

Fig. 9

9/15

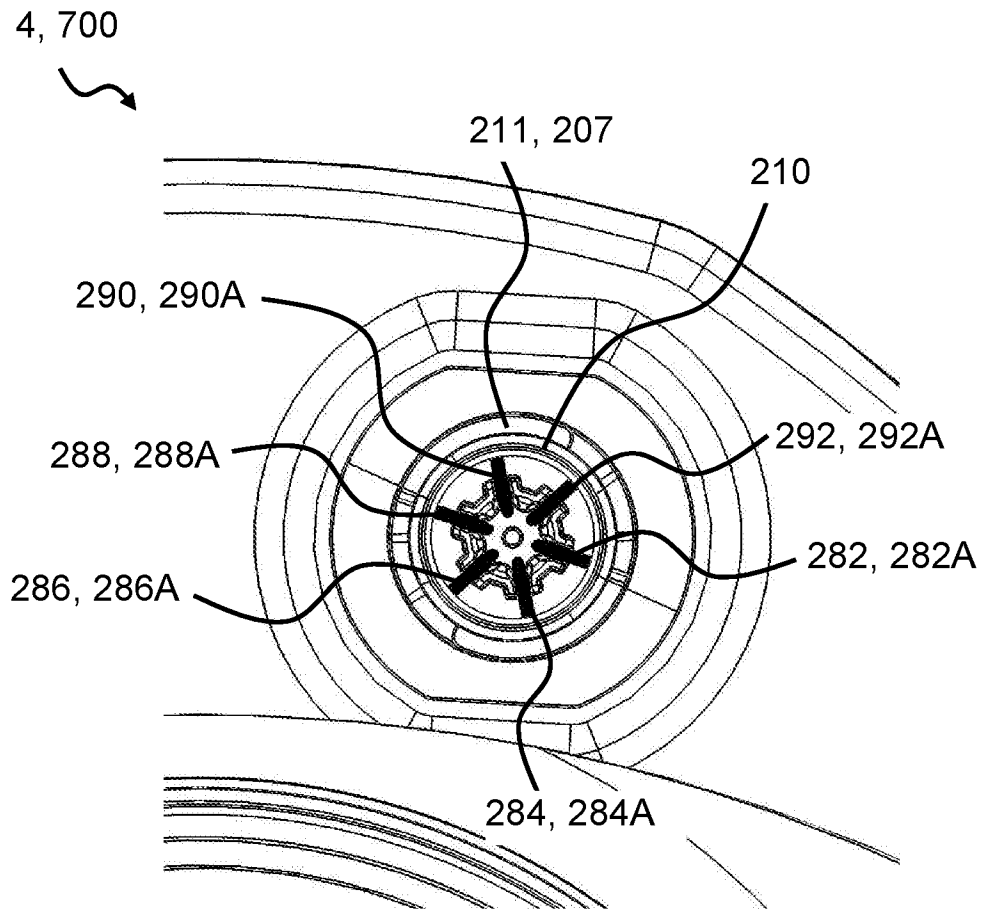

Fig. 10

10/15

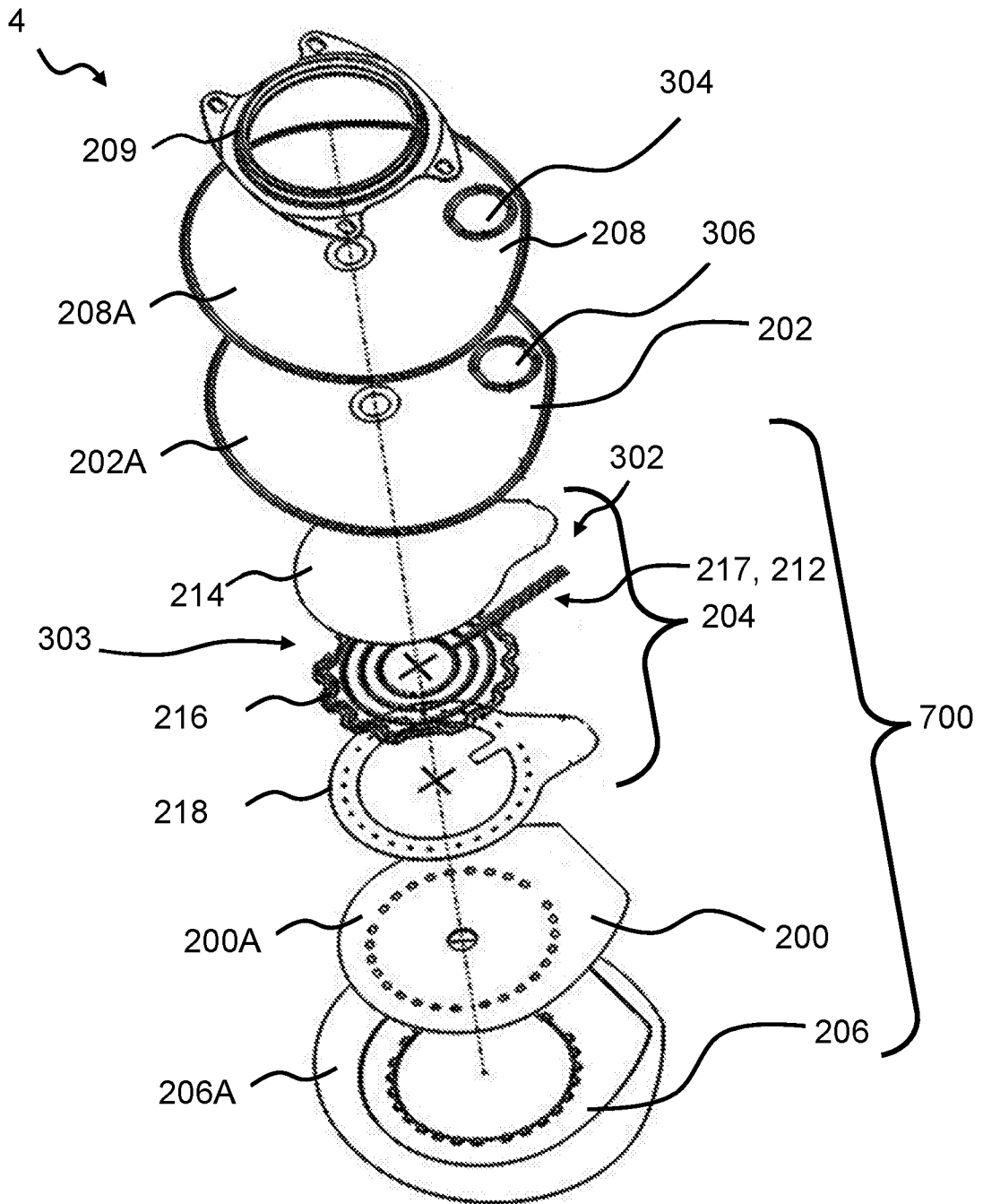

Fig. 11

11/15

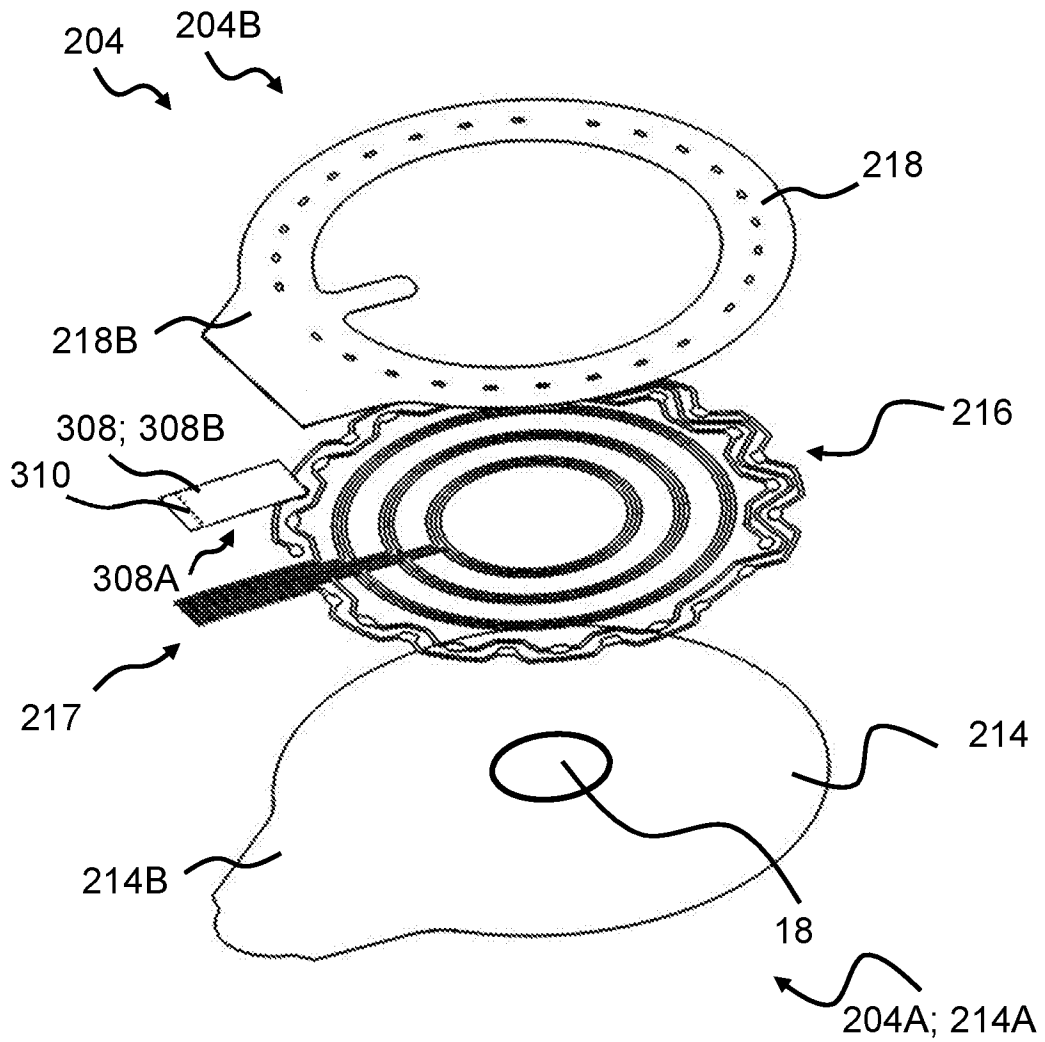

Fig. 12

12/15

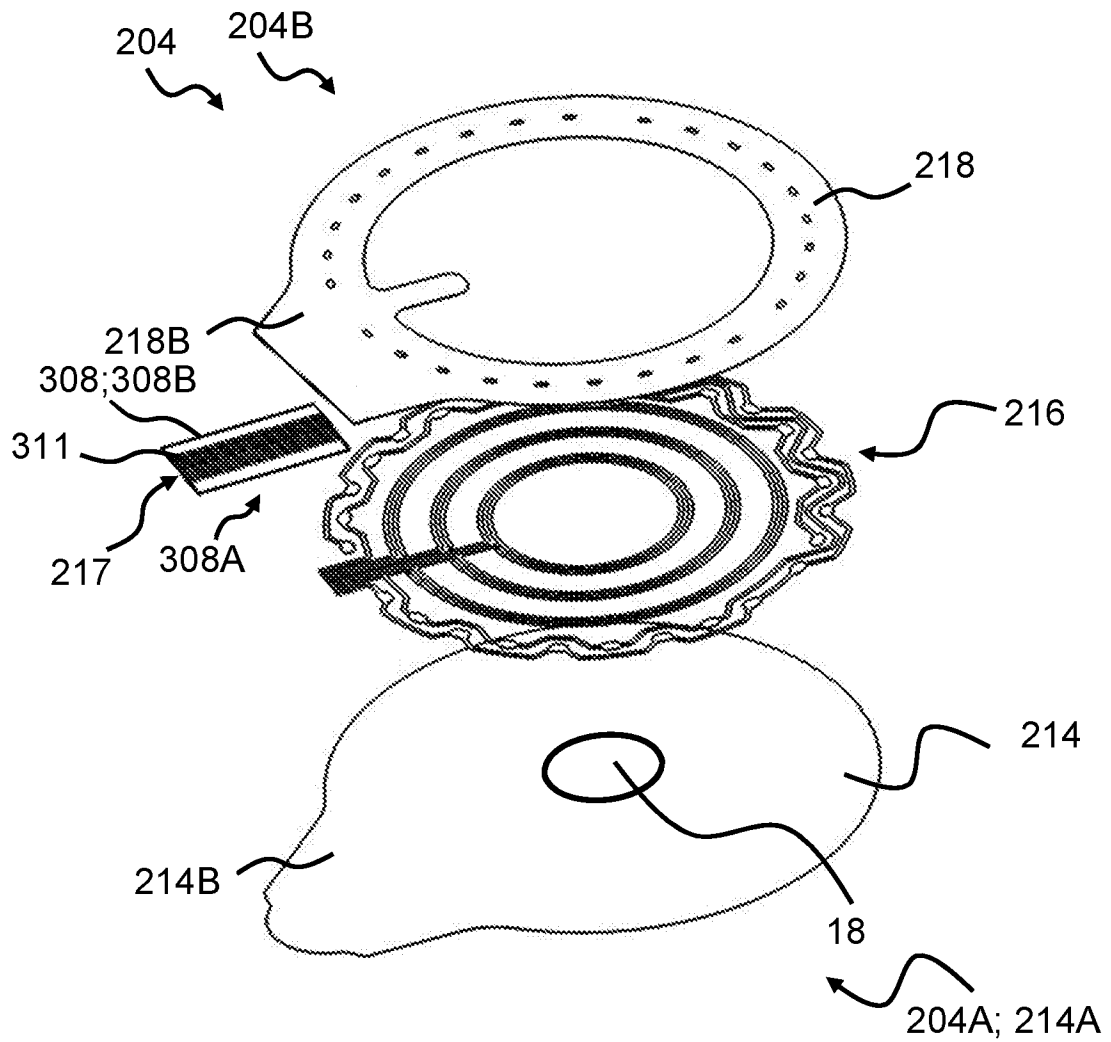

Fig. 13

13/15

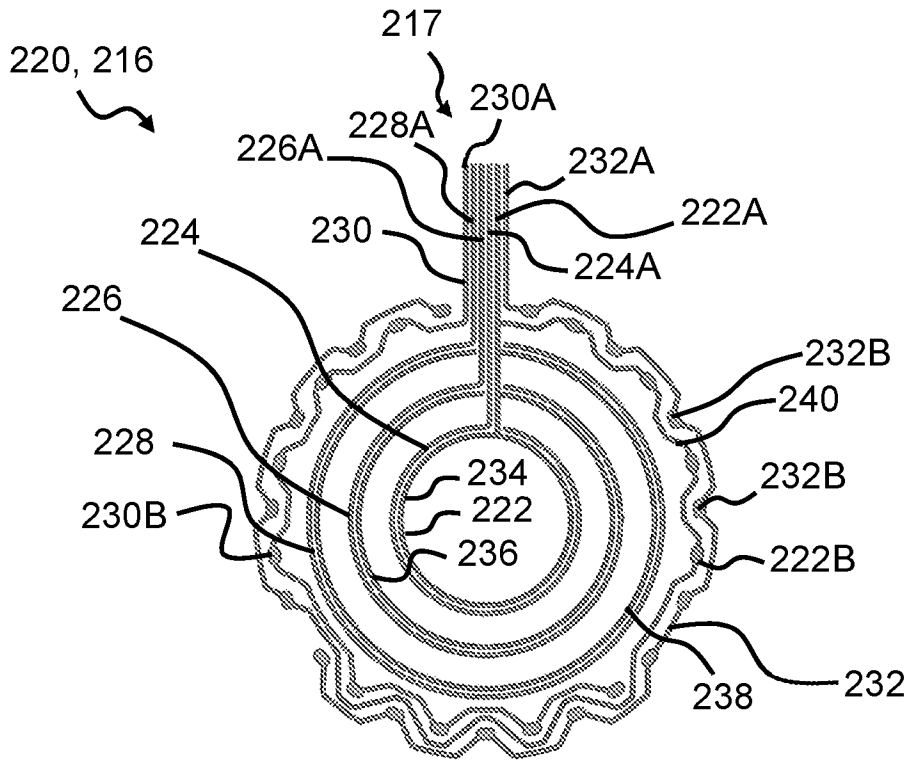

Fig. 14

14/15

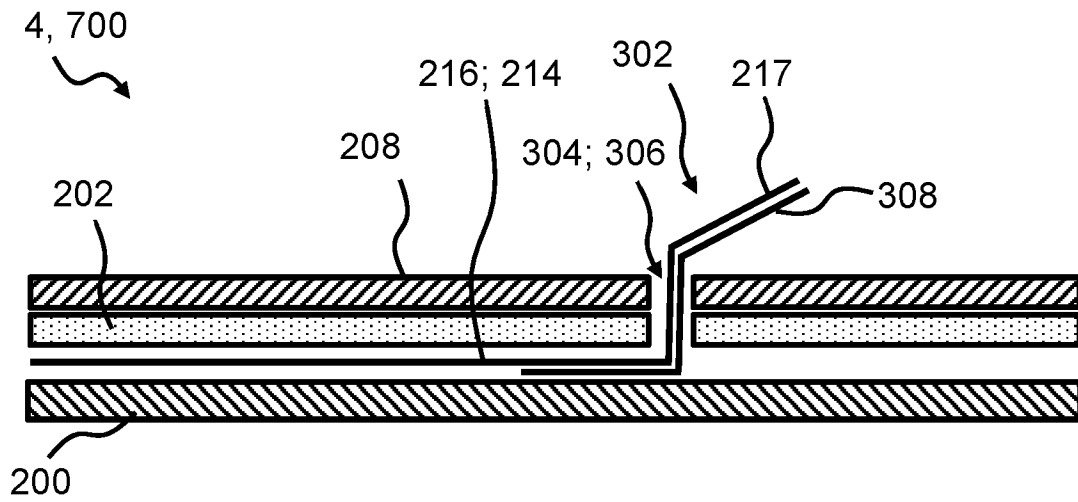

Fig. 15

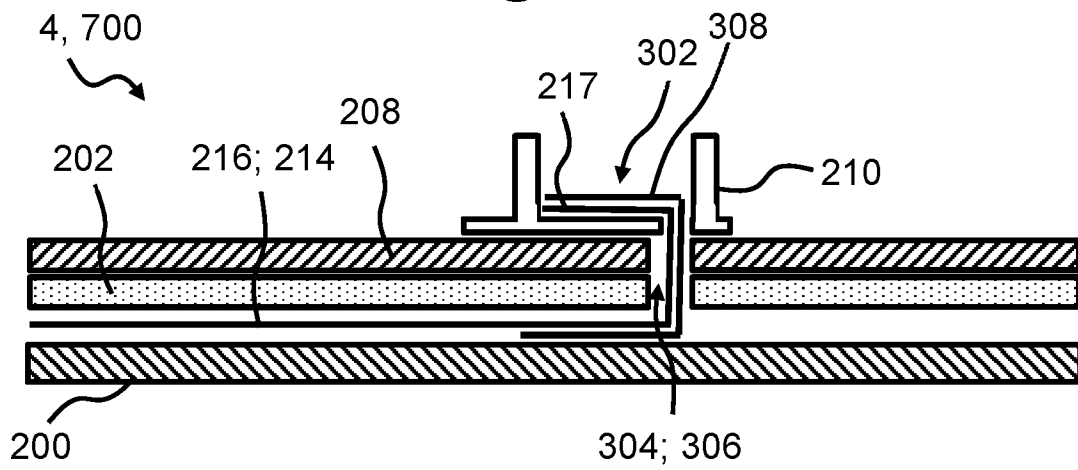

Fig. 16

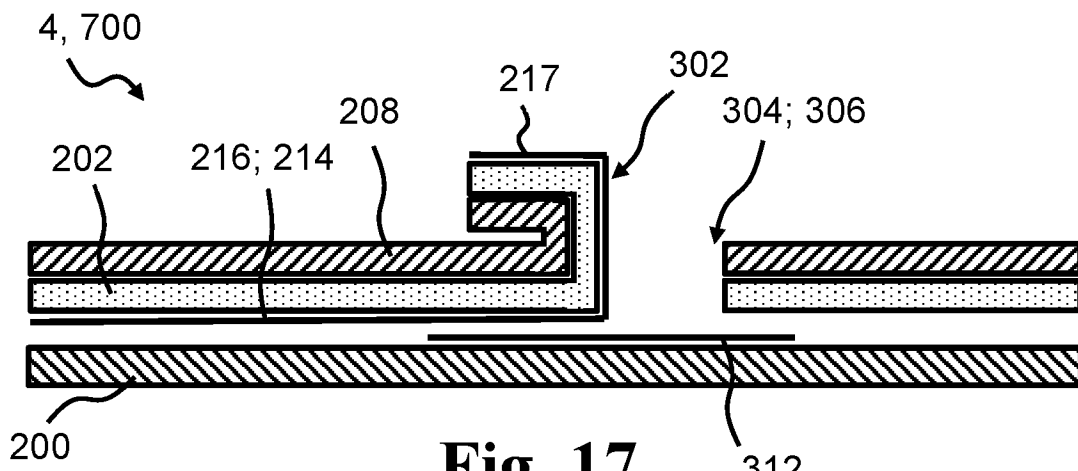

Fig. 17

15/15

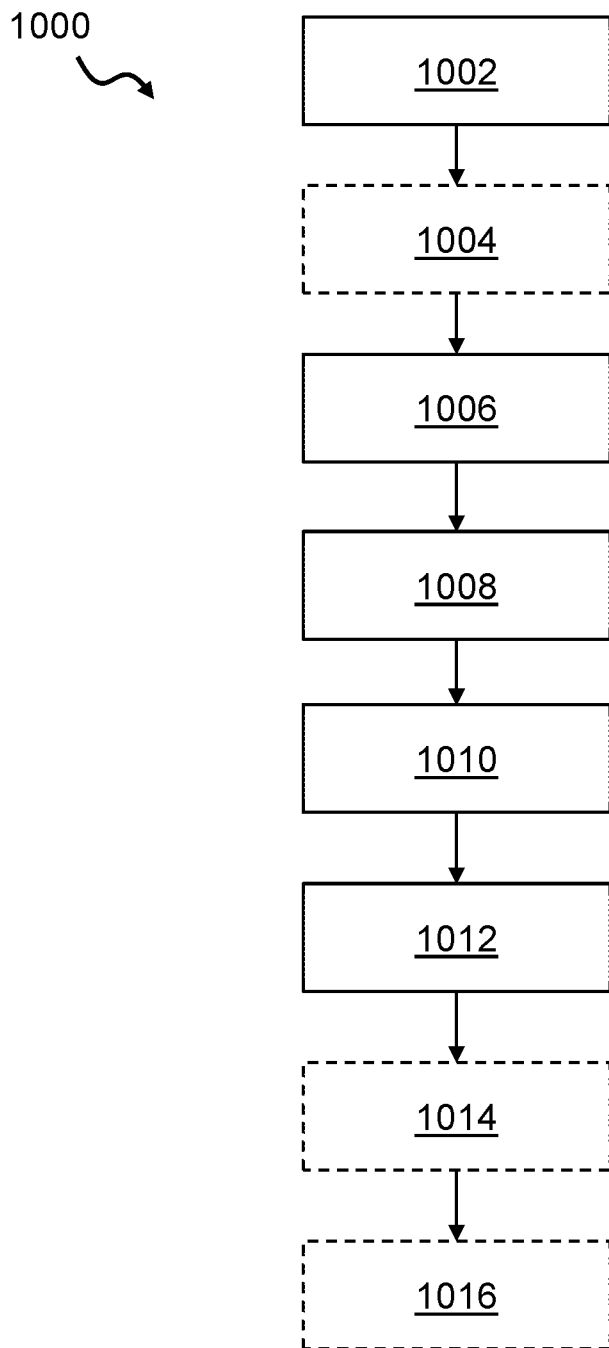

Fig. 18