

(19) World Intellectual Property  
Organization  
International Bureau



(43) International Publication Date  
27 May 2004 (27.05.2004)

PCT

(10) International Publication Number  
WO 2004/043251 A1

(51) International Patent Classification<sup>7</sup>: A61B 5/00

[US/US]; 30 St. Mark's Place #2D, New York, NY 10003 (US). ZULUAGA, Andres, F. [CO/US]; 130 Bowdoin Street, Apt. 1808, Boston, MA 02108 (US).

(21) International Application Number:  
PCT/US2003/035692

(74) Agent: LICHAUCO, Faustino, A.; Fish & Richardson, P.C., 225 Franklin Street, Boston, MA 02110-2804 (US).

(22) International Filing Date:  
7 November 2003 (07.11.2003)

(81) Designated States (national): AE, AG, AL, AM, AT, AU, AZ, BA, BB, BG, BR, BY, BZ, CA, CH, CN, CO, CR, CU, CZ, DE, DK, DM, DZ, EC, EE, ES, FI, GB, GD, GE, GH, GM, HR, HU, ID, IL, IN, IS, JP, KE, KG, KP, KR, KZ, LC, LK, LR, LS, LT, LU, LV, MA, MD, MG, MK, MN, MW, MX, MZ, NO, NZ, OM, PH, PL, PT, RO, RU, SD, SE, SG, SK, SL, TJ, TM, TN, TR, TT, TZ, UA, UG, US, UZ, VN, YU, ZA, ZM, ZW.

(25) Filing Language: English

(26) Publication Language: English

(30) Priority Data:  
10/289,741 7 November 2002 (07.11.2002) US

(63) Related by continuation (CON) or continuation-in-part (CIP) to earlier application:  
US 10/289,741 (CON)  
Filed on 7 November 2002 (07.11.2002)

(84) Designated States (regional): ARIPO patent (BW, GH, GM, KE, LS, MW, MZ, SD, SL, SZ, TZ, UG, ZM, ZW), Eurasian patent (AM, AZ, BY, KG, KZ, MD, RU, TJ, TM), European patent (AT, BE, BG, CH, CY, CZ, DE, DK, EE, ES, FI, FR, GB, GR, HU, IE, IT, LU, MC, NL, PT, RO, SE, SI, SK, TR), OAPI patent (BF, BJ, CF, CG, CI, CM, GA, GN, GQ, GW, ML, MR, NE, SN, TD, TG).

(71) Applicant (for all designated States except US): INFRAREDIX, INC. [US/US]; 125 Cambridge Park Drive, Cambridge, MA 02140 (US).

(72) Inventors; and

Published:  
— with international search report

(75) Inventors/Applicants (for US only): FURNISH, Simon

[Continued on next page]

(54) Title: SPECTROSCOPE WITH MODIFIED FIELD-OF-VIEW

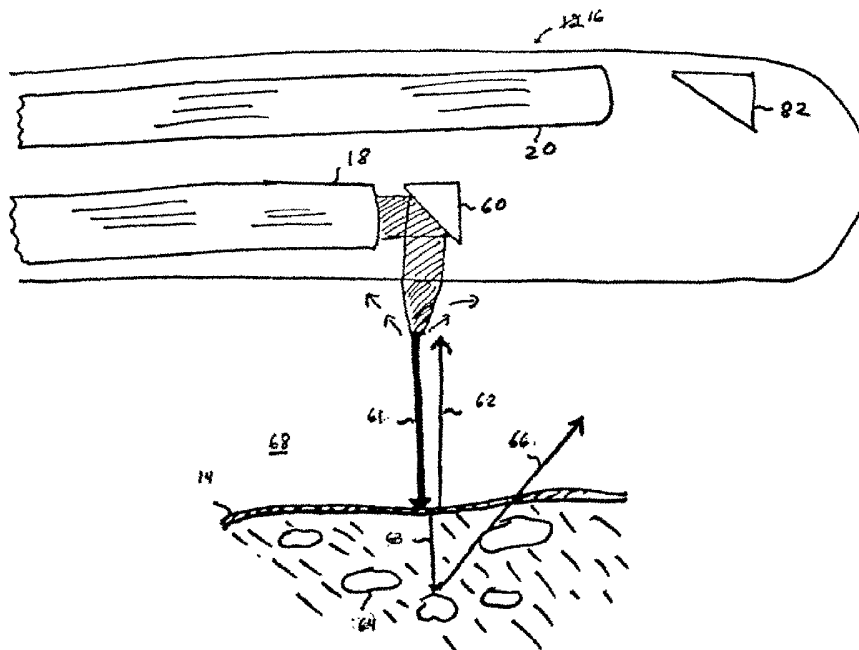

(57) Abstract: Catheter (16) includes deliver fiber (18) and a delivery mirror (60). When light exists axially from the deliver fiber (18), the delivery mirror (60) intercepts that light and redirects it radially outward to the arterial wall (14).



WO 2004/043251 A1



- 
- *before the expiration of the time limit for amending the claims and to be republished in the event of receipt of amendments*
- For two-letter codes and other abbreviations, refer to the "Guidance Notes on Codes and Abbreviations" appearing at the beginning of each regular issue of the PCT Gazette.*

# SPECTROSCOPE WITH MODIFIED FIELD-OF-VIEW

## FIELD OF INVENTION

5           The invention relates to spectroscopy, and in particular, to spectrosopes for detecting vulnerable plaques within a wall of a blood vessel.

## BACKGROUND

Atherosclerosis is a vascular disease characterized by a modification of the walls of blood-carrying vessels. Such modifications, when they occur at discrete  
10   locations or pockets of diseased vessels, are referred to as plaques. Certain types of plaques are associated with acute events such as stroke or myocardial infarction. These plaques are referred to as “vulnerable plaques.” A vulnerable plaque typically includes a lipid-containing pool of necrotic debris separated from the blood by a thin fibrous cap. In response to elevated intraluminal pressure or vasospasm, the fibrous  
15   cap can become disrupted, exposing the contents of the plaque to the flowing blood. The resulting thrombus can lead to ischemia or to the shedding of emboli.

One method of locating vulnerable plaque is to peer through the arterial wall with infrared light. To do so, one inserts a catheter through the lumen of the artery. The catheter includes a delivery fiber for illuminating a spot on the arterial wall with  
20   infrared light. Various particles in the blood, as well as the arterial wall itself, scatter or reflect much of this light. A small portion of the light, however, penetrates the arterial wall, scatters off structures deep within the wall. Some of this deeply-scattered light re-enters the lumen. This re-entrant light be collected by a collection fiber within the catheter and subjected to spectroscopic analysis.

25           Light scattered only by the blood or reflected off the vessel walls surface contains no information about structures within the wall. To the extent that such light enters the collection fiber, it represents unwanted noise. Hence, the collection fiber preferably rejects such light and directs only re-entrant light into the collection fiber.

## SUMMARY

The invention is based on the recognition that one can use the differing spatial distributions of specularly reflected light and re-entrant light to preferentially guide re-entrant light into the collection fiber.

5 In one aspect, the invention includes a spectroscope having an optical fiber extending through a catheter. An obstruction is placed so as to occlude a portion of a field-of-view of the optical fiber.

A variety of obstructions are within the scope of the invention. For example, in some embodiments, the obstruction includes a ledge extending across a chord of fiber  
10 core so as to occlude a region bounded by the chord and by a boundary of the core. In other embodiments, the obstruction includes a tab extending at least part way across the core. In yet other embodiments, the obstruction includes a disk disposed to occlude a circular portion of the core.

The obstruction need not be adjacent to the fiber. For example, in  
15 spectroscopes that include a mirror in optical communication with the optical fiber, the obstruction can be a non-reflective region of the mirror shaped to obstruct a portion of the fibers field-of-view. Or, for spectroscopes that include a perforated mask enclosing the fiber, the obstruction can be walls forming an aperture in optical communication with the fiber, the aperture being shaped to obstruct a portion of the  
20 fibers field-of-view. For spectroscopes that include a transparent sheath surrounding the fiber, the obstruction can be an opaque band in optical communication with the fiber and positioned to obstruct a portion of the fibers field-of-view.

The resulting field of view of the optical fiber depends in part on the shape of the obstruction. In some embodiments, the obstruction has a shape selected to form a  
25 field-of-view in the shape of a truncated ellipse. This includes the special case of a truncated circle, a circle being an ellipse with coincident foci. In other embodiments, the obstruction has a shape selected to form a crescent-shaped field-of-view. In yet other embodiments, the obstruction has a shape selected to form an annular field-of-view. Additional embodiments include those in which the obstruction has a diffracting  
30 edge, the geometry of which is selected to form a selected field-of-view.

Another aspect of the invention includes a spectroscope having an optical fiber that extends through a catheter. An optical system having a finite focal length is disposed to be in optical communication with the fiber.

5 In some embodiments, the optical system includes an optical element having a curved surface. Examples of such optical elements include mirrors and lenses. The curved surface can be a cylindrical surface, or it can be a paraboloid, an ellipsoid, a hyperboloid, or a sphere. In other embodiments, the optical system includes an optical element with a spatially varying index of refraction.

10 Another aspect of the invention includes a spectroscope having a catheter and an optical fiber extending through the catheter. In this aspect, a diffracting element configured to form a selected field-of-view is in optical communication with the fiber.

15 Embodiments of the spectroscope include those in which the diffracting element is a transmissive diffracting element and those in which the diffracting element is reflective diffracting element. Other embodiments include those in which the diffracting element is a diffraction grating, an amplitude grating, a phase grating, or a holographic grating.

20 Unless otherwise defined, all technical and scientific terms used herein have the same meaning as commonly understood by one of ordinary skill in the art to which this invention belongs. Although methods and materials similar or equivalent to those described herein can be used in the practice or testing of the present invention, suitable methods and materials are described below. All publications, patent applications, patents, and other references mentioned herein are incorporated by reference in their entirety. In case of conflict, the present specification, including definitions, will control. In addition, the materials, methods, and examples are  
25 illustrative only and not intended to be limiting.

Other features and advantages of the invention will be apparent from the following detailed description, and from the claims.

**BRIEF DESCRIPTION OF THE FIGURES**

FIG. 1 is a schematic of a system for identifying vulnerable plaque in a patient.

FIG. 2 is a cross-section of the catheter in FIG. 1.

FIG. 3 is a view of an optical bench at the tip assembly of the catheter in FIG. 1.

5 FIG. 4 is a schematic of the paths traveled by light from the illumination fiber of FIG. 1.

FIG. 5 is a cross-section of the spatial light distribution shown in FIG. 4.

FIG. 6 is a transverse cut of the collection fiber and optical bench showing a known collection-fiber stop.

10 FIG. 7 is a schematic of the field-of-view of the collection fiber of FIG. 6 superimposed on the spatial light distribution of FIG. 4.

FIGS. 8 and 9 are longitudinal and transverse cross-sections of an optical bench having an extended collection-fiber stop.

15 FIG. 10 is a schematic of a field-of-view of resulting from the extended collection-fiber stop of FIGS. 8 and 9.

FIGS. 11 and 12 are longitudinal and transverse cross-sections of an optical bench having a tab protruding from the collection-fiber stop.

FIG. 13 is a schematic of a crescent-shaped field of view resulting from the tab of FIGS. 11 and 12.

20 FIGS. 14 and 15 are longitudinal and transverse cross-sections of an optical bench having an occluding disk supported on a post protruding from the collection-fiber stop.

FIG. 16 is a plan view of a mask on the collection mirror.

FIG. 17 is a schematic of a perforated shell enclosing the distal tip assembly.

FIG. 18 is a schematic of a banded sheath enclosing the distal tip assembly.

FIG. 19 is a schematic of a mirror having a curved surface in optical communication with the collection fiber.

FIGS. 20 and 21 are schematics of exemplary fields-of-view as modified by  
5 mirrors having various curved surfaces.

FIG. 22 is a schematic of a lens in optical communication with the collection fiber.

FIG. 23 is a schematic of a transmissive diffracting element in optical communication with the collection fiber.

10 FIG. 24 is a schematic of a reflective diffractive element integrated onto the surface of the collection mirror.

## DETAILED DESCRIPTION

### System Overview

15 FIG. 1 shows a diagnostic system **10** for identifying vulnerable plaque **12** in an arterial wall **14** of a patient. The diagnostic system features a catheter **16** to be inserted into a selected artery, e.g. a coronary artery, of the patient. A delivery fiber **18** and a collection fiber **20** extend between a distal end **22** and a proximal end **24** of the catheter **16**.

20 As shown in FIG. 2, the catheter **16** includes a sheath **26** surrounding a rotatable torque cable **28**. The delivery fiber **18** extends along the center of a torque cable **28**, and the collection fiber **20** extends parallel to, but radially displaced from, the delivery fiber **18**. The rotatable torque cable **28** spins at a rate between approximately 1 revolution per second and 400 revolutions per second.

25 At the distal end **21** of the catheter **16**, a tip assembly **30** coupled to the torque cable **28** directs light traveling axially on the delivery fiber **18** toward an illumination spot **32** on the arterial wall **14**. The tip assembly **30** also collects light from a field-of-view **34** on the arterial wall **14** and directs that light into the collection fiber **20**.

A multi-channel coupler 36 driven by a motor 38 engages the proximal end 24 of the torque cable 28. When the motor 38 spins the multi-channel coupler 36, both the coupler 36, the torque cable 28, and the tip assembly 30 spin together as a unit. This feature enables the diagnostic system 10 to circumferentially scan the arterial wall 14 with the illumination spot 32.

In addition to spinning the torque cable 28, the multi-channel coupler 36 guides light from a laser 40 (or other light source such as a light-emitting diode, a super-luminescent diode, or an arc lamp) into the delivery fiber 18 and guides light emerging from the collection fiber 20 into one or more detectors (not visible in FIG. 1).

The detectors provide an electrical signal indicative of light intensity to an amplifier 42 connected to an analog-to-digital ("A/D") converter 44. The A/D converter 44 converts this signal into digital data that can be analyzed by a processor 46 to identify the presence of a vulnerable plaque 12 hidden beneath the arterial wall 14.

### **Optical Bench**

FIG. 3 shows an optical bench 48 in which are seated the collection fiber 20 and the delivery fiber 18. The optical bench 48 is seated in a recess 50 between first and second side walls 52A-B of the distal end of a housing 54. The housing 54 is in turn coupled to the distal end of the torque cable 28. The recess 50 is just wide enough to enable the collection fiber 20 and the delivery fiber 18 to nestle adjacent to each other. A floor 56 extending between the first and second side walls 52A-B and across the recess 50 supports both the collection and delivery fibers 18, 20.

Just distal to the end of the delivery fiber 18, a portion of the optical bench 48 forms a frustum 58. The frustum 58 extends transversely only half-way across the optical bench 48, thereby enabling the collection fiber 20 to extend distally past the end of the delivery fiber 18.

The frustum 58 has an inclined surface facing the distal end of the delivery fiber 18 and a vertical surface facing the distal end of the optical bench 48. The



inclined surface forms a 135 degree angle relative to the floor 56. Other angles can be selected depending on the direction in which light from the delivery fiber 18 is to be directed. A reflective material coating the inclined surface forms a beam re-director, which in this case is a delivery mirror 60. When light exits axially from the delivery  
5 fiber 18, the delivery mirror 60 intercepts that light and redirects it radially outward to the arterial wall 14. Examples of other beam re-directors include prisms and diffraction gratings.

### **Spatial distribution of light**

Referring to FIG. 4, as the light travels radially outward from the delivery  
10 mirror 60, it encounters the blood that fills a lumen 68. As a result of scattering by particles in the blood, a large number of photons never reach the wall 14. This loss of energy is shown schematically by a progressive narrowing of the beam as it nears the wall 14. The remaining photons 61 eventually reach the arterial wall 14. Some of these photons are reflected from the wall 14. These specularly reflected photons 62  
15 carry little or no information about structures 64 behind the arterial wall 14 and are therefore of little value. Of those photons 63 that penetrate the wall, many are absorbed. The remainder 66 are scattered by structures 64 behind the wall 14. After having been scattered, a few of these remaining photons 66 again pass through the arterial wall 14 and re-enter the lumen 68. This remnant of the light 61 originally  
20 incident on the wall, which is referred to herein as the "re-entrant light 66," carries considerable information about the structures 64 behind the arterial wall 14. It is therefore this re-entrant light 66 that is to be guided into the collection fiber 20.

As suggested by FIG. 4, re-entrant light 66 tends to re-enter the lumen along an annular re-entrant zone that is radially separated from the specularly reflected light  
25 62. FIG. 5, which illustrates the spatial distribution of light from the viewpoint of the catheter 16, shows such a re-entrant zone 70 surrounding an illumination spot 32. Photons received from within the re-entrant zone 70 are predominantly those that have been scattered from within the arterial wall 14. The re-entrant zone 70 has an inner circumference 74 and an outer circumference 76. Between the inner circumference 74  
30 and the illumination spot 32 lies a specular zone 78. Photons received from the

specular zone 78 are predominantly those that have undergone specular reflection. Proceeding radially outward beyond the outer circumference 76, one comes to a dark zone 80, where the number of photons of either type is so small as to be immeasurable.

#### 5 **Modifying the field-of-view**

To collect as many photons of re-entrant light 66 as possible, the field-of-view 32 should overlap the re-entrant zone 70 to the greatest extent possible. To the extent that the field-of-view 32 extends outside the re-entrant zone 70, it should extend into the dark zone 80 and away from the specular zone 78.

#### 10 **Modifying the field-of-view with an obstruction**

Referring back to FIG. 3, the collection fiber 20 extends past the end of the delivery fiber 18 until it terminates at a plane that is coplanar with the vertical face of the frustum 58. Just beyond the distal end of the collection fiber 20, a portion of the optical bench 48 forms an inclined surface extending transversely across the optical bench 48 and making a 135 degree angle relative to the floor 56. A reflective material coating the inclined surface forms a collection mirror 82. This collection mirror 82 reflects light incident from the arterial wall 14 into the distal end of the collection fiber 20. The collection mirror 82 and the collection fiber 20 together form a collection subsystem 84 that collects light from a field-of-view 32.

20 A delivery-fiber stop 86 molded into the optical bench 48 proximal to the frustum 58 facilitates placement of the delivery fiber 18 at a desired location proximal to the delivery mirror 60. Similarly, a collection-fiber stop 88 molded into the optical bench 48 just proximal to the collection mirror 82 facilitates placement of the collection fiber 20 at a desired location proximal to the collection mirror 82.

25 Referring now to FIG. 6, the collection fiber has an optically transmissive core 90 surrounded by a protective cladding 92. The collection-fiber stop 88 extends upward from the floor 56 to provide an abutment surface for the collection fiber 20. A portion of the cladding 92 rests on the abutment surface. The core 90 does not rest on the abutment surface and therefore remains unobstructed.

A distal tip assembly **94** configured as shown in FIG. 6 results in a field-of-view **32** shaped like an ellipse **96** with its major axis **98** extending along the radial direction, as shown in FIG. 7. The extent to which the ellipse **96** overlaps the re-entrant zone **70** is one measure of how effective the collection subsystem **84** is at  
5 guiding re-entrant light into the collection fiber **20**.

The extent of the overlap between the ellipse **96** and the re-entrant zone **70** depends on the eccentricity of the ellipse and its position relative to the re-entrant zone **70**. The eccentricity of the ellipse **96** is governed by the angular orientation of the collection mirror **82**. Its position relative to the re-entrant zone **70** is controlled by  
10 varying the position and angle of the delivery mirror **60** relative to the collection mirror **82**.

To avoid collecting photons from the specular zone **78**, the ellipse **96** is positioned to be tangent to the inner circumference **74** of the re-entrant zone **70**, with its minor axis **100** located radially outward from the point of tangency.

15 FIGS. 8 and 9 show an extended collection-fiber stop **102** forms an abutment surface that extends part-way across the core **90** of the collection fiber. The occluded portion of the core **90** is bounded by a chord extending across the core **90** and by an arc that forms part of the boundary between the core **90** and the cladding **92**. The resulting modified field-of-view is a truncated ellipse **106** having a base **108**, as  
20 shown in FIG. 10. A dotted line **110** outlines a portion **112** of the ellipse truncated by the extended collection-fiber stop **102**. To avoid collecting photons from the specular zone **78**, the truncated ellipse **106** is positioned such that the base **108** of the truncated ellipse **106** is tangent to the inner circumference **74** of the re-entrant zone **70**.

The overlap between the truncated ellipse **106** and the re-entrant zone **70** in  
25 FIG. 10 is greater than the overlap between the full ellipse **96** and the re-entrant zone **70** in FIG. 7. The extent to which these overlaps differ represents an increase in the number of photons gathered from the re-entrant zone **70**.

Other beam-shaping structures can be used to prevent light from illuminating the entire core **90** and to thereby shape the field-of-view **32**. In FIGS. 11 and 12, for

example, a tab **118** having a curved distal tip **119** protrudes vertically upward from the collection-fiber stop **88** and obstructs part of the core **90**. When placed in front of a collection fiber **20** having a suitably high numerical aperture, this results in a crescent shaped field-of-view **120** as shown in FIG. 13.

5           Another example, shown in FIGS. 14 and 15, is an occulting disk **122** mounted on a post **124** that protrudes from the collection-fiber stop **88**. The post **124** supports the occulting disk **122** so that its center coincides with the center of the core **90**. The diameter of the occulting disk **122** is slightly smaller than the diameter of the core **90**. The difference between the diameter of the occulting disk **122** and that of the core **90**  
10 is selected to provide an annular field-of-view that closely matches the size and shape of the re-entrant zone **70**.

Structures that effectively block light from entering a portion of the collection fiber need not be adjacent to the collection fiber **20**, as shown in FIGS. 11-12 and in FIGS. 14-15. In fact, such structures can be placed anywhere along the optical path  
15 between the collection fiber **20** and the arterial wall **14**. For example, a beam-shaping structure that effectively obstructs a portion of the core **90** can be a mask **125** formed directly on the collection mirror **82**, as shown in FIG. 16. Another example of such a structure is a perforated shell **127** rotationally coupled to the torque cable **28**, as shown in FIG. 17. The perforated shell **127** has a delivery aperture **129** to permit light  
20 from the delivery fiber **18** to pass through the shell **127** unimpeded, and a collection aperture **131** shaped to block a portion of the light incident on the collection mirror **82**. In another example, shown in FIG. 18, an opaque band **133** on a transparent distal tip **135** of the stationary sheath **26** is positioned to obscure a portion of the collection mirror **82**. The band **131** extends circumferentially around the sheath so that the  
25 collection mirror **82** is obscured as the torque cable **28** rotates the collection mirror **82**.

Any of the foregoing beam-shaping structures can have an edge that is modified to diffract light incident thereon in a manner that causes the field-of-view to have a pre-selected geometry. Such an edge can be formed by providing protrusions or indentations having a dimension on the order of the wavelength of light to be  
30 observed.

### Modifying the field-of-view with an optical system

The beam-shaping function of the foregoing obstructions can also be achieved by providing an optical system in optical communication with the collection mirror **82**. Such an optical system can include a collection mirror **82** with a curved surface, a lens assembly, or both. For example, in FIG. 19, the collection mirror **82** has a cylindrical surface rather than a planar surface. The resulting field-of-view for the configuration shown in FIG. 19 is an ellipse **126** having an aspect ratio closer to unity, as shown in FIG. 20. Other curved surfaces can result in fields-of-view or alternatively an ellipse **128** in which it is the minor axis of an ellipse **128**, rather than the major axis, that extends radially, as shown in FIG. 21.

Curved surfaces other than a cylindrical surface can also be used to shape the field-of-view to more closely approximate the shape of the re-entrant zone **70**. For example, the curved surface can be a conic surface, such as a paraboloid, a hyperboloid, or an ellipsoid. Alternatively, the surface can be a spherical surface.

Optical elements other than reflecting surfaces can also be used to shape the field-of-view. For example, in FIG. 22, a lens assembly **130** disposed in optical communication with the collection fiber **20** provides control over the shape of the field-of-view.

The lens assembly **130** can include one or more discrete lenses. One or more lenses in the lens assembly can have a suitably curved surface. Another lens suitable for use in a lens assembly is a GRIN (graduated index of refraction) lens having a spatially varying index of refraction. In addition, the lens assembly **130** need not be composed of discrete lenses but can instead include a lens that is integral with the distal end of the collection fiber **20**. Such a lens **132**, an example of which is shown in FIG. 22, can be made by shaping the distal end of the collection fiber **20** so that it has the desired optical characteristics.

The beam-shaping function provided by the foregoing examples of optical systems can also be provided by a diffracting element **134** placed along the optical path, as shown in FIG. 23. Examples of diffracting elements **134** include diffraction gratings, amplitude gratings, spatial light modulators, and holographic gratings. The

5 diffracting element can be a transmissive or reflective. A transmissive diffracting element 134 can be placed anywhere along the optical path traversed by the collection beam, either integrated onto the distal end of the collection fiber 20, as shown in FIG. 23, or mounted separately on the optical path, either between the collection fiber 20 and the mirror 82 as shown in FIG. 23, or between the collection mirror 82 and the arterial wall. A reflective diffracting element 134 can be integrated directly onto the surface of the collection mirror 82 as shown in FIG. 24.

10 The surfaces of the delivery and collection mirrors 60, 82 can be coated with a reflective coating, such as gold, silver or aluminum. These coatings can be applied by known vapor deposition techniques. Alternatively, for certain types of plastic, a reflective coating can be electroplated onto those surfaces. Or, the plastic itself can have a reflective filler, such as gold or aluminum powder, incorporated within it.

15 The optical bench 48 is manufactured by injection molding a plastic into a mold. In addition to being simple and inexpensive, the injection molding process makes it easy to integrate the elements of the optical bench 48 into a single monolith and to fashion structures having curved surfaces. Examples of suitable plastics include liquid crystal polymers (LCPs), polyphenylsulfone, polycarbonate, acrylonitrile butadiene-styrene ("ABS"), polyamide ("NYLON"), polyethersulfone, and polyetherimide. Alternatively, the optical bench can be manufactured by micro-20 machining plastic or metal, by lithographic methods, by etching, by silicon optical bench fabrication techniques, or by injection molding metal. Materials other than plastics can be used to manufacture the housing 54 and the optical bench 48. Such materials include metals, quartz or glass, and ceramics.

25 The floor 56 in the illustrated embodiment is integral to the housing 54. However, the floor 56 can also be made part of the optical bench 48.

As described herein, the housing 54 and the optical bench 48 are manufactured separately and later joined. However, the housing 54 and the optical bench 48 can also be manufactured together as a single unitary structure.

**Using the catheter**

In use, the distal tip assembly **94** is inserted into a blood vessel, typically an artery, and guided to a location of interest. Light is then directed into the delivery fiber **18**. This light exits the delivery fiber **18** at its distal tip, reflects off the delivery mirror **60** in a direction away from the plane containing the delivery and collection fibers **18**, **20**, and illuminates an illumination spot **32** on the wall of the artery. Light penetrating the arterial wall **14** is then scattered by structures within the wall. Some of this scattered light re-enters the blood vessel and impinges on the plane and onto the collection mirror **82**. The collection mirror **82** directs this light into the collection fiber **20**.

Alternatively, light incident on the wall **14** can stimulate fluorescence from structures on or within the wall **14**. The portion of this fluorescent light that is incident on the collection mirror **82** is directed into the collection fiber **20**.

**OTHER EMBODIMENTS**

It is to be understood that while the invention has been described in conjunction with the detailed description thereof, the foregoing description is intended to illustrate and not limit the scope of the invention, which is defined by the scope of the appended claims. Other aspects, advantages, and modifications are within the scope of the following claims.

We claim:

## CLAIMS

1. A spectroscope comprising:
  - a catheter;
  - an optical fiber extending through the catheter, the optical
  - 5 fiber having a field-of-view,; and
  - an obstruction disposed to occlude a portion of the field-of-view.
2. The spectroscope of claim 1, wherein the obstruction comprises a ledge extending across a chord of the core, the ledge occluding a region
- 10 bounded by the chord and by a boundary of the core.
3. The spectroscope of claim 1, wherein the obstruction comprises a tab extending at least part way across the core.
4. The spectroscope of claim 3, wherein the tab comprises a curved tip.
5. The spectroscope of claim 1, wherein the obstruction comprises a disk
- 15 disposed to occlude a circular portion of the field-of-view.
6. The spectroscope of claim 1, further comprising a mirror in optical communication with the optical fiber; and wherein the obstruction comprises a non-reflective region of the mirror, the non-reflective region being shaped to obstruct a portion of the field-of-view thereof.
- 20 7. The spectroscope of claim 1, further comprising a perforated mask enclosing the fiber; and wherein the obstruction comprises walls forming an aperture in optical communication with the fiber, the aperture being shaped to obstruct a portion of the field-of-view thereof.
8. The spectroscope of claim 1, further comprising a transparent sheath
- 25 surrounding the fiber; and wherein the obstruction comprises an opaque band in optical communication with the fiber and positioned to obstruct a portion of the field-of-view thereof.



9. The spectroscope of claim 1, wherein the obstruction has a shape selected to form a field-of-view in the shape of a truncated ellipse.
10. The spectroscope of claim 1, wherein the obstruction has a shape selected to form a field-of-view in the shape of a crescent.
- 5 11. The spectroscope of claim 1, wherein the obstruction has a shape selected to form an annular field-of-view.
12. The spectroscope of claim 1, wherein the obstruction has an edge configured to diffract light incident thereon to form a selected field-of-view.
- 10 13. A spectroscope comprising:
- a catheter;
  - an optical fiber extending through the catheter;
  - an optical system in optical communication with the fiber, the optical system having a finite focal length.
- 15 14. The spectroscope of claim 13, wherein the optical system comprises an optical element having a curved surface.
15. The spectroscope of claim 13, wherein the optical system comprises an optical element having a spatially varying dielectric constant.
16. The spectroscope of claim 14, wherein the curved surface comprises a  
20 cylindrical surface.
17. The spectroscope of claim 14, wherein the curved surface includes a portion having a shape selected from the group consisting of a paraboloid, an ellipsoid, a hyperboloid, and a sphere.
18. The spectroscope of claim 13, wherein the optical system comprises a  
25 mirror having a curved surface.

19. The spectroscope of claim 13, wherein the optical system comprises a lens.
20. A spectroscope comprising:
- a catheter;
- 5                   an optical fiber extending through the catheter;
- a diffracting element in optical communication with the fiber, the diffracting element being configured to form a selected field-of-view.
21. The spectroscope of claim 20, wherein the diffracting element  
10                   comprises a transmissive diffracting element.
22. The spectroscope of claim 20, wherein the diffracting element comprises a reflective diffracting element.
23. The spectroscope of claim 20, wherein the diffracting element comprises a diffraction grating.
- 15   24. The spectroscope of claim 20, wherein the diffracting element comprises an amplitude grating.
25. The spectroscope of claim 20, wherein the diffracting element comprises a phase grating.
26. The spectroscope of claim 20, wherein the diffracting element  
20                   comprises a holographic grating.

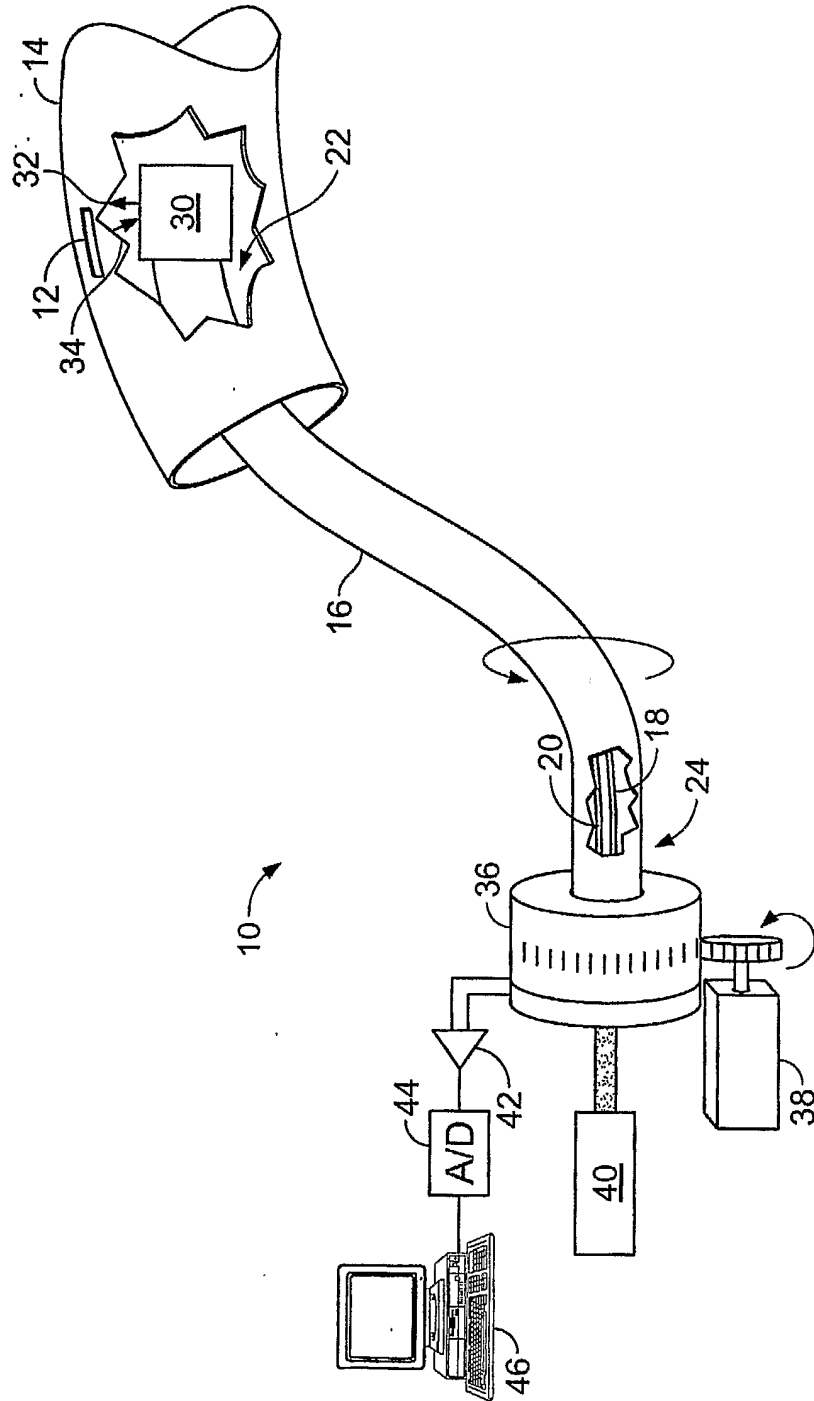

FIG. 1

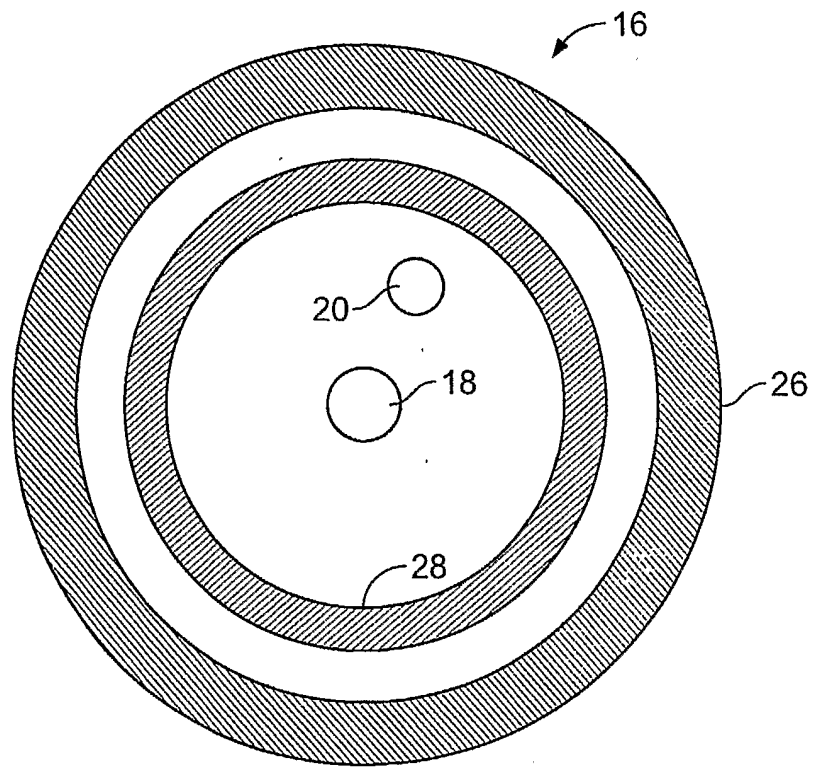

FIG. 2

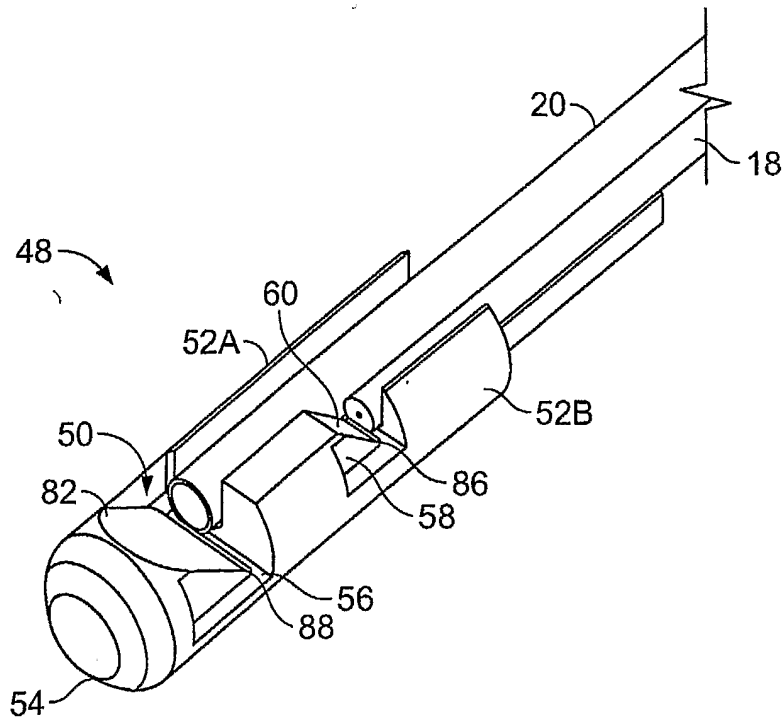

FIG. 3

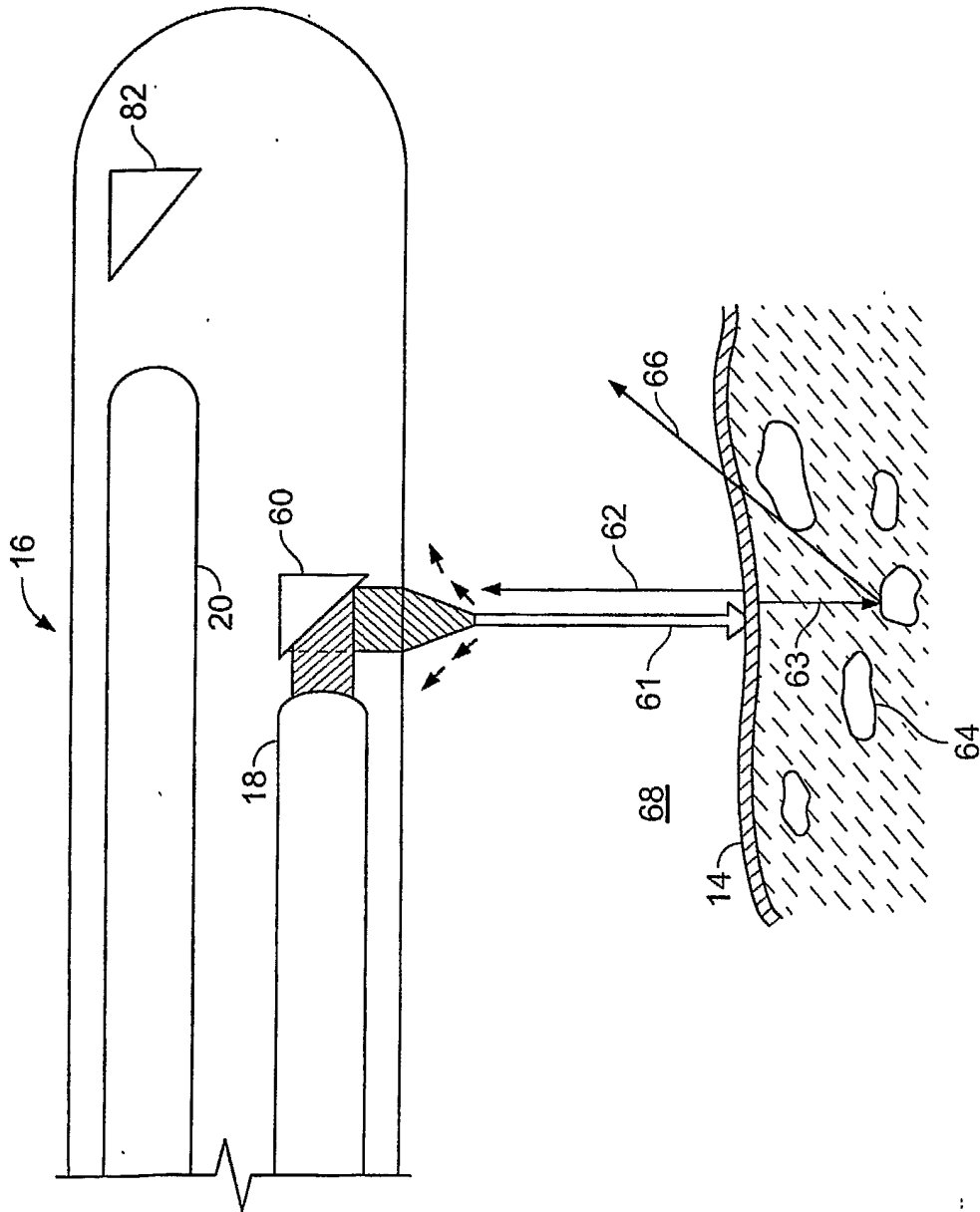

FIG. 4

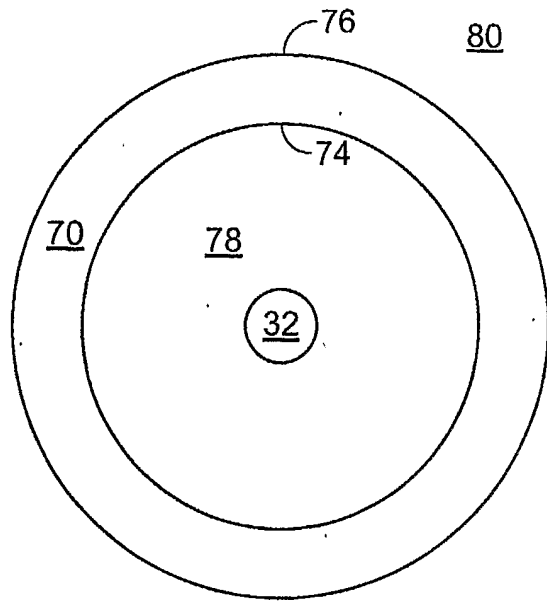

FIG. 5

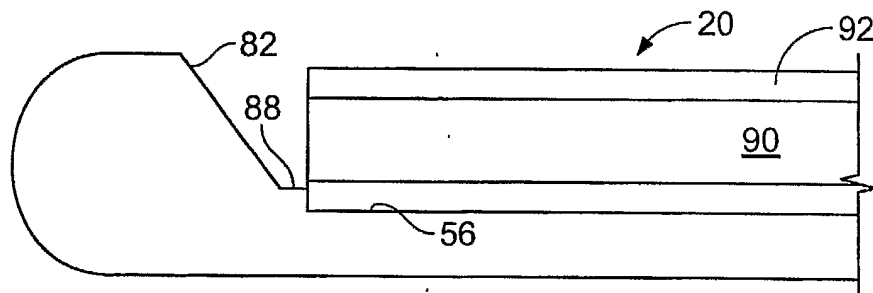

FIG. 6  
(Prior Art)

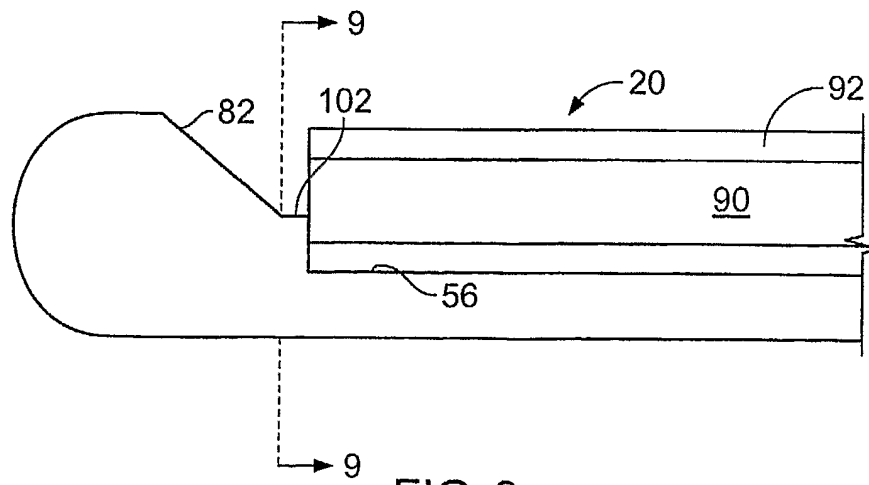

FIG. 8

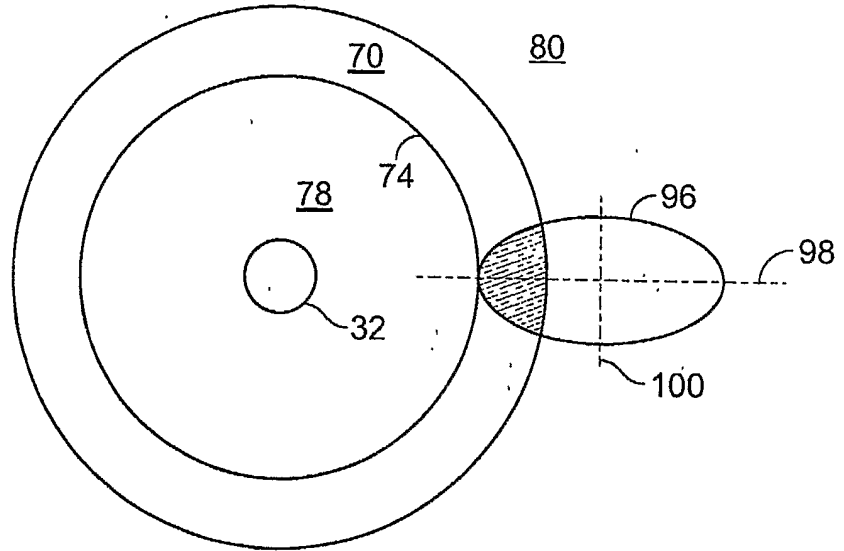

FIG. 7

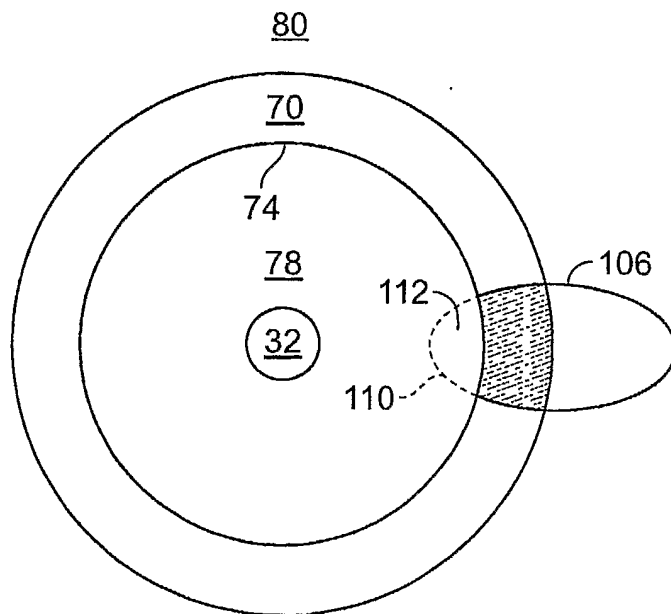

FIG. 10

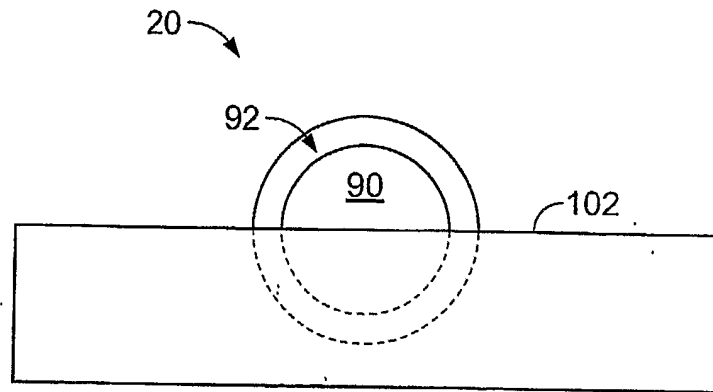

FIG. 9

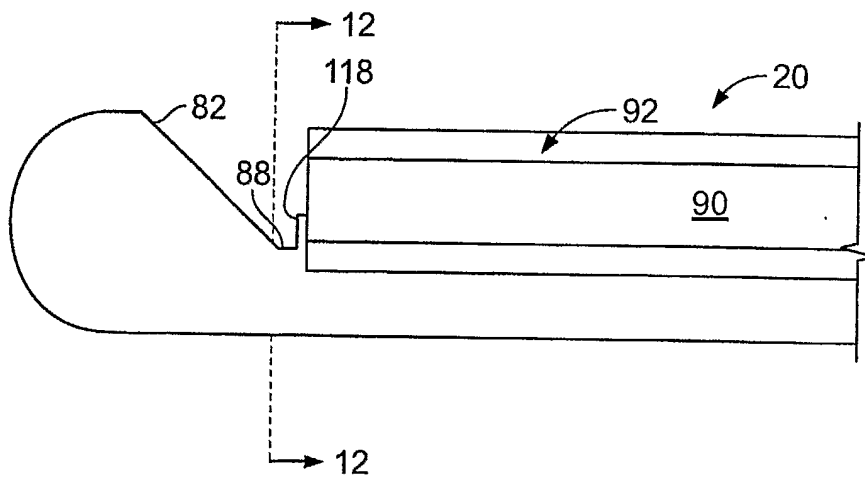

FIG. 11

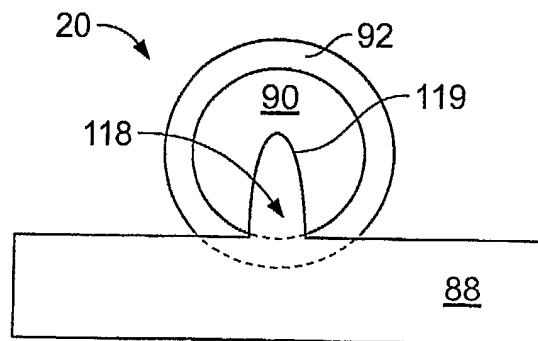

FIG. 12



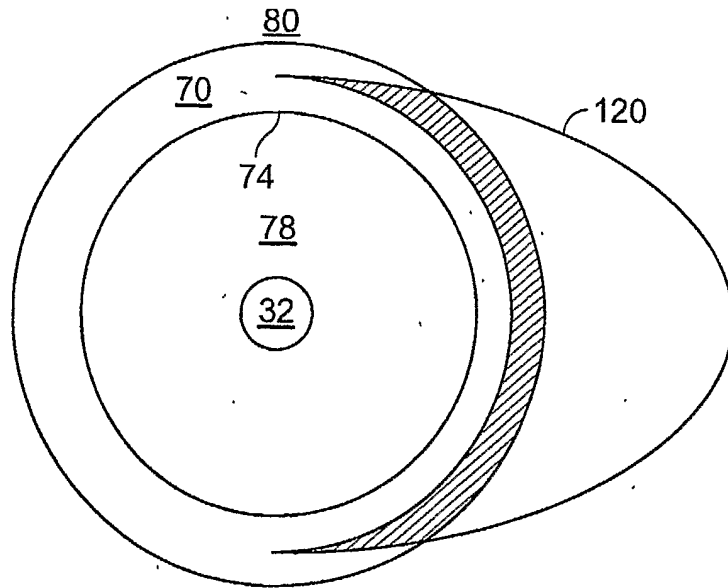

FIG. 13

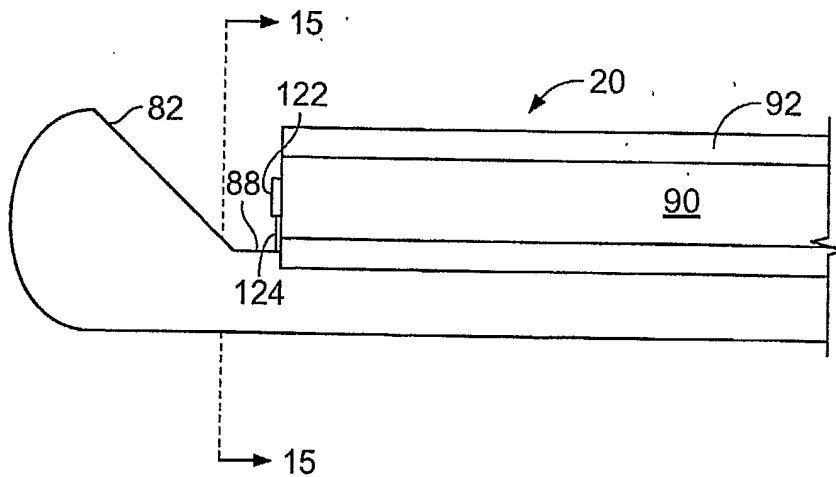

FIG. 14

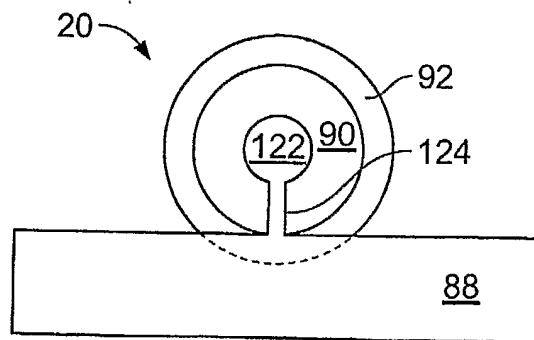

FIG. 15

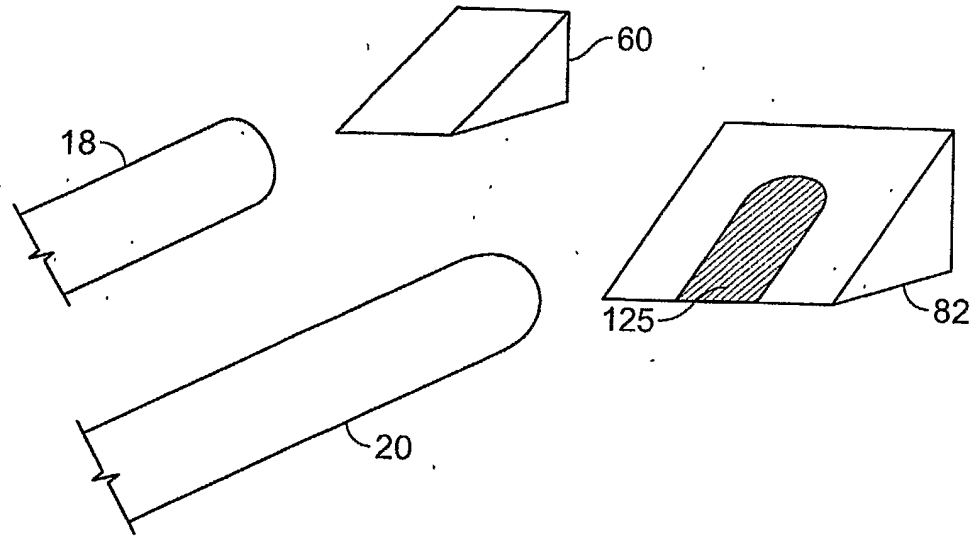

FIG. 16

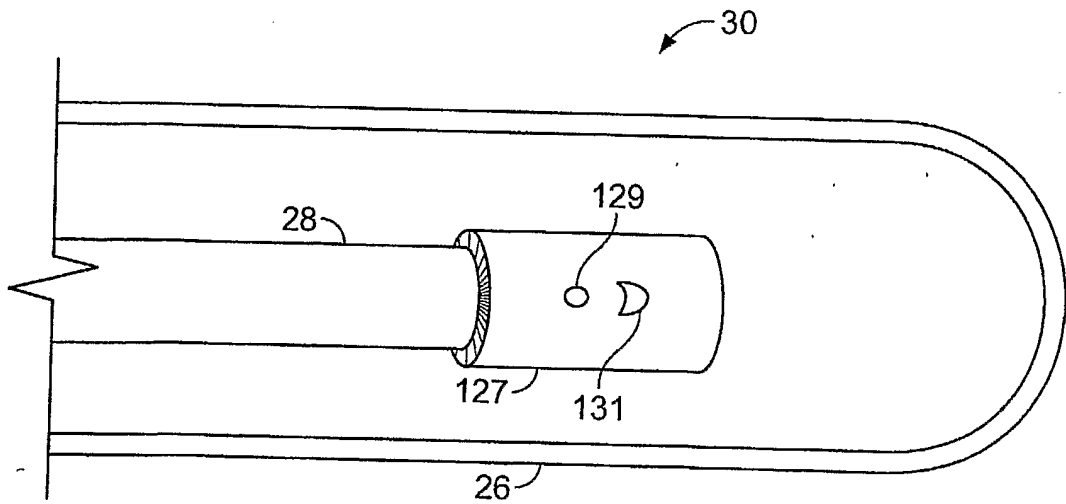

FIG. 17

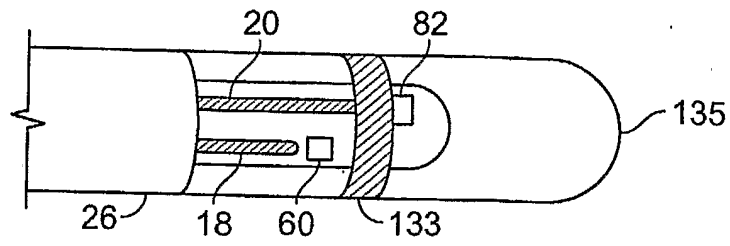

FIG. 18

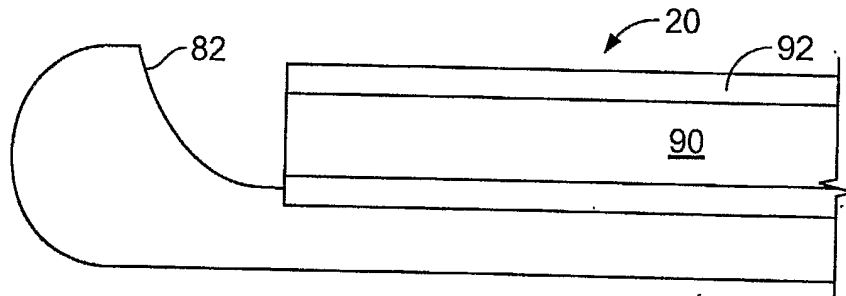

FIG. 19

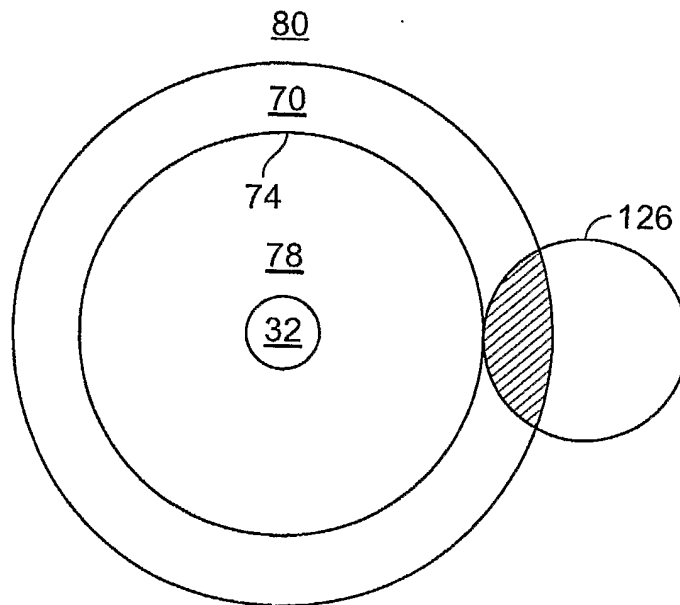

FIG. 20

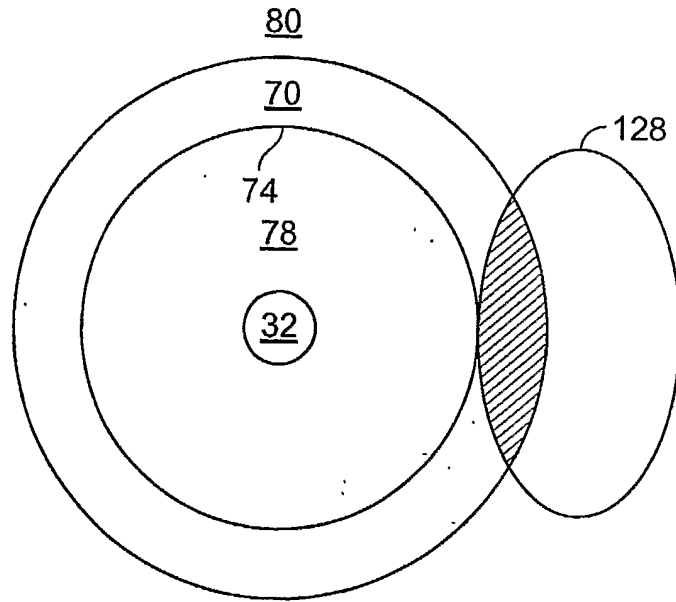

FIG. 21

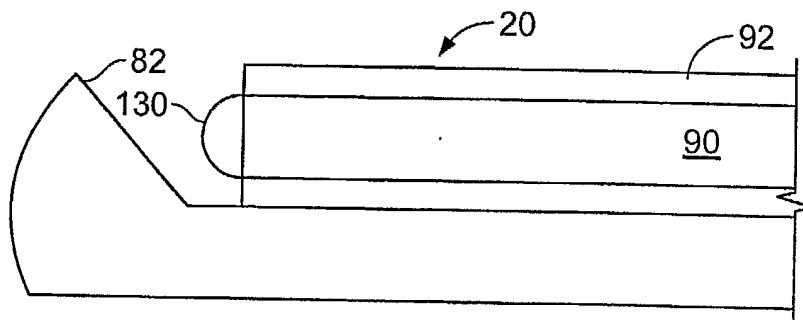

FIG. 22

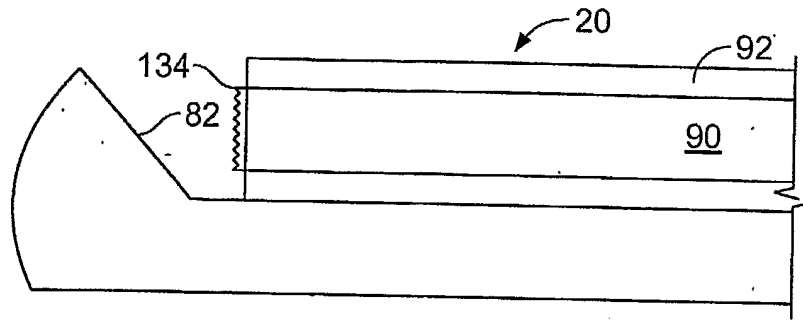

FIG. 23

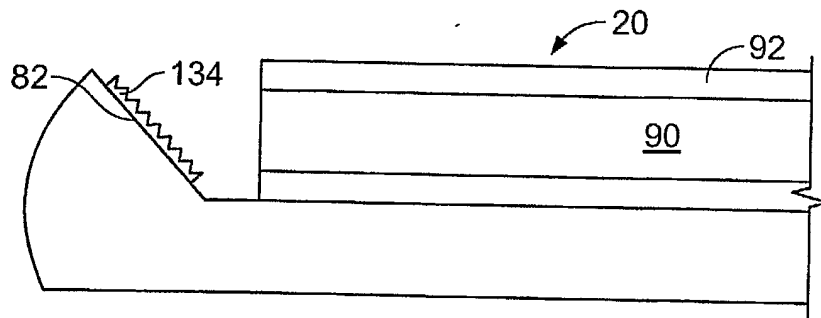

FIG. 24

# INTERNATIONAL SEARCH REPORT

International application No.

PCT/US03/35692

**A. CLASSIFICATION OF SUBJECT MATTER**

IPC(7) : A61B 5/00  
 US CL : 600/478

According to International Patent Classification (IPC) or to both national classification and IPC

**B. FIELDS SEARCHED**

Minimum documentation searched (classification system followed by classification symbols)

U.S. : 600/104, 114, 473, 476, 478; 604/22, 164.01, 164.02; 385/12

Documentation searched other than minimum documentation to the extent that such documents are included in the fields searched

Electronic data base consulted during the international search (name of data base and, where practicable, search terms used)  
 WEST

**C. DOCUMENTS CONSIDERED TO BE RELEVANT**

Category *	Citation of document, with indication, where appropriate, of the relevant passages	Relevant to claim No.
X, P	US 6,564,087 A (PITRIS et al) 13 May 2003 (13.05.2003), see entire document and in particular Figure 1A and see col. 7, lines 35-67 and col. 8, lines 1-7.	1-26

Further documents are listed in the continuation of Box C.

See patent family annex.

* Special categories of cited documents:	"T"
"A" document defining the general state of the art which is not considered to be of particular relevance	later document published after the international filing date or priority date and not in conflict with the application but cited to understand the principle or theory underlying the invention
"E" earlier application or patent published on or after the international filing date	"X" document of particular relevance; the claimed invention cannot be considered novel or cannot be considered to involve an inventive step when the document is taken alone
"L" document which may throw doubts on priority claim(s) or which is cited to establish the publication date of another citation or other special reason (as specified)	"Y" document of particular relevance; the claimed invention cannot be considered to involve an inventive step when the document is combined with one or more other such documents, such combination being obvious to a person skilled in the art
"O" document referring to an oral disclosure, use, exhibition or other means	"&" document member of the same patent family
"P" document published prior to the international filing date but later than the priority date claimed	

Date of the actual completion of the international search

13 March 2004 (13.03.2004)

Date of mailing of the international search report

**13 APR 2004**

Name and mailing address of the ISA/US

Mail Stop PCT, Attn: ISA/US  
 Commissioner for Patents  
 P.O. Box 1450  
 Alexandria, Virginia 22313-1450

Facsimile No. (703) 305-3230

Authorized officer

Eleni Mantis Mercader

Telephone No. 703 308-0858