



- (51) International Patent Classification:
H02J 17/00 (2006.01)
- (21) International Application Number:
PCT/US2013/052551
- (22) International Filing Date:
29 July 2013 (29.07.2013)
- (25) Filing Language: English
- (26) Publication Language: English
- (30) Priority Data:
61/676,718 27 July 2012 (27.07.2012) US
- (71) Applicant: THORATEC CORPORATION [US/US];
6035 Stoneridge Drive, Pleasanton, CA 94588 (US).
- (72) Inventor: HANSEN, John, Freddy; 6035 Stoneridge
Drive, Pleasanton, CA 94588 (US).
- (74) Agents: ZLOGAR, Thomas, M. et al.; Shay Glenn LLP,
2755 Campus Drive, Suite 210, San Mateo, CA 94403
(US).

- (81) Designated States (unless otherwise indicated, for every kind of national protection available): AE, AG, AL, AM, AO, AT, AU, AZ, BA, BB, BG, BH, BN, BR, BW, BY, BZ, CA, CH, CL, CN, CO, CR, CU, CZ, DE, DK, DM, DO, DZ, EC, EE, EG, ES, FI, GB, GD, GE, GH, GM, GT, HN, HR, HU, ID, IL, IN, IS, JP, KE, KG, KN, KP, KR, KZ, LA, LC, LK, LR, LS, LT, LU, LY, MA, MD, ME, MG, MK, MN, MW, MX, MY, MZ, NA, NG, NI, NO, NZ, OM, PA, PE, PG, PH, PL, PT, QA, RO, RS, RU, RW, SC, SD, SE, SG, SK, SL, SM, ST, SV, SY, TH, TJ, TM, TN, TR, TT, TZ, UA, UG, US, UZ, VC, VN, ZA, ZM, ZW.
- (84) Designated States (unless otherwise indicated, for every kind of regional protection available): ARIPO (BW, GH, GM, KE, LR, LS, MW, MZ, NA, RW, SD, SL, SZ, TZ, UG, ZM, ZW), Eurasian (AM, AZ, BY, KG, KZ, RU, TJ, TM), European (AL, AT, BE, BG, CH, CY, CZ, DE, DK, EE, ES, FI, FR, GB, GR, HR, HU, IE, IS, IT, LT, LU, LV, MC, MK, MT, NL, NO, PL, PT, RO, RS, SE, SI, SK, SM, TR), OAPI (BF, BJ, CF, CG, CI, CM, GA, GN, GQ, GW, KM, ML, MR, NE, SN, TD, TG).

[Continued on next page]

(54) Title: RESONANT POWER TRANSMISSION COILS AND SYSTEMS

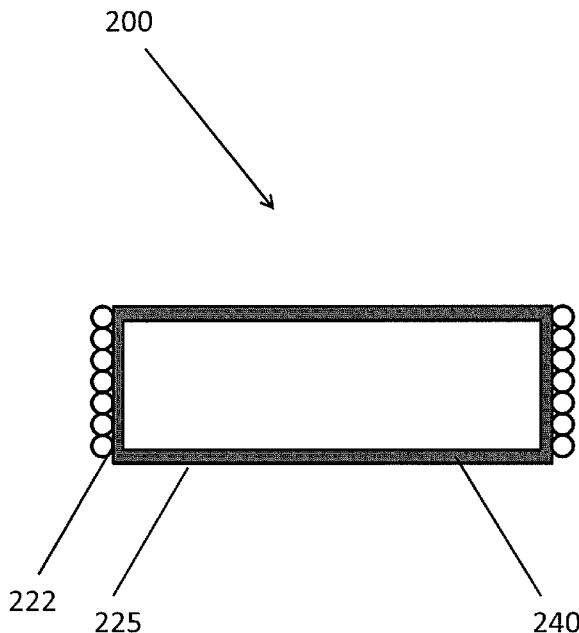

FIG. 11

(57) Abstract: An improved wireless transmission system for transferring power over a distance. The system includes a transmitter generating a magnetic field and a receiver for inducing a voltage in response to the magnetic field. In various respects, the receiver is configured to be implanted in a body. The receiver may include a housing enclosing a receiving coil and associated electronic components, a covering around at least a portion of the housing, and at least two wires wrapped around the housing to form a plurality of turns. The covering may be formed of a ferrite material configured to both magnetically shield a respective portion of the internal volume of the housing and redirect incoming magnetic flux from the transmitter to improve efficiency. Methods of use are also provided.

WO 2014/018973 A1



Published:

— with international search report (Art. 21(3))

— before the expiration of the time limit for amending the claims and to be republished in the event of receipt of amendments (Rule 48.2(h))

RESONANT POWER TRANSMISSION COILS AND SYSTEMS**CROSS-REFERENCE TO RELATED APPLICATIONS**

[0001] This application claims the benefit of US Provisional Patent Application No.
5 61/676,718, filed on July 27, 2012, titled "Resonant Power Transmission Coils and Systems".

INCORPORATION BY REFERENCE

[0002] All publications and patent applications mentioned in this specification are herein
10 incorporated by reference to the same extent as if each individual publication or patent
application was specifically and individually indicated to be incorporated by reference.

FIELD

[0003] This disclosure relates generally to methods and apparatus for transmitting and
15 receiving power wirelessly, and in various respects, mechanical circulatory support.

BACKGROUND

[0004] Powered devices need to have a mechanism to supply power to the operative parts.
Typically systems use a physical power cable to transfer energy over a distance. There has been
20 a continuing need for systems that can transmit power efficiently over a distance without
physical structures bridging the physical gap.

[0005] Systems and methods that supply power without electrical wiring are sometimes
referred to as wireless energy transmission (WET). Wireless energy transmission greatly
expands the types of applications for electrically powered devices. One such example is the field
25 of implantable medical devices. Implantable medical devices typically require an internal power
source able to supply adequate power for the reasonable lifetime of the device or an electrical
cable that traverses the skin. Typically an internal power source (e.g. battery) is feasible for only
low power devices like sensors. Likewise, a transcutaneous power cable significantly affects
quality of life (QoL), infection risk, and product life, among many drawbacks.

[0006] More recently there has been an emphasis on systems that supply power to an
30 implanted device without using transcutaneous wiring. This is sometimes referred to as a
Transcutaneous Energy Transfer System (TETS). Frequently energy transfer is accomplished
using two magnetically coupled coils set up like a transformer so power is transferred
magnetically across the skin. Conventional systems are relatively sensitive to variations in

position and alignment of the coils. In order to provide constant and adequate power, the two coils need to be physically close together and well aligned.

[0007] Other solutions have focused on making one or both of the coils larger so the magnetic flux field is larger. This provides greater freedom of movement of the coils while ensuring efficient power transfer. This approach has several drawbacks. Because the components are implanted in the body, a larger receiving coil makes surgical placement more difficult and limits the implantation options. In cases where the transmitter is large relative to the receiver, it is likely the transmitter will be set up to generate a large field, then the receiver will have to adjust to keep its output in a reasonable range, and optimize for efficiency.

[0008] Enlarging the transmission coil has several drawbacks. The transmitter is effectively set up to blast out the maximum field, which necessitates careful power management on the receiver side. The transmitter is set up to operate passively, and the receiver is doing most of the control. Thus, this system can be complex to implement, especially in sensitive applications like implantable medical devices. A larger transmission coil decreases quality of life (QoL) because the patient must carry a larger, heavier coil. Moreover, larger coils inherently lead to greater complexity. The system inherently carries the risk of providing too much power to the internal load and/or battery. Higher power transfer can also lead to excessive heating, which risk damaging the internal organs and tissue.

[0009] In cases where the transmitter is smaller, such as a mobile wearable coil, transmitter efficiency is important. The system is highly sensitive to receiver coil position and orientation and may not provide adequate power transfer in all cases.

[00010] Another drawback with conventional wireless power transmission systems is high susceptibility to interference. Even minor changes to the field from external factors can significantly affect the transmitter and receiver. For example, if a metallic object is introduced into the system, it will affect the magnetic flux and in turn the system will not operate efficiently.

SUMMARY OF THE DISCLOSURE

[00011] In summary, one aspect of the present invention is directed to an implantable receiver for wirelessly receiving energy from a transmitter, including a housing enclosing volume including a receiving coil and components susceptible to interference by magnetic flux; a covering around at least a portion of the housing; at least one wire wrapped around the housing to form a plurality of turns; wherein the covering is formed of a ferrite material configured to

both magnetically shield a respective portion of the internal volume and redirect incoming magnetic flux.

5 [00012] In various embodiments, the receiver includes coil circuitry including at least two coils; and receiver circuitry configured to transmit power excited in the receiver coil in response to exposure to a field to a load. In various embodiments, the load is an implantable medical device including an operative component. The operative component may be a circulatory support device. The operative component may be a blood pump for supporting and/or replacing the function of the heart. The operative component may be a left ventricular assist device, right ventricular assist device, bi-ventricular assist device, and/or total artificial heart. All or part of
10 the operative component may be external to the body.

[00013] In various embodiments, the covering comprises a plurality of tiles. In various embodiments, the covering covers the entire housing periphery.

[00014] Various aspects of the invention are directed to a system including a receiver, a transmitter for generating a magnetic field to the receiver, and an implantable mechanical
15 circulatory support (MCS) device. In various embodiments, the MCS device is configured to be powered by energy from the receiver. In various embodiments, the system further includes an implantable battery. In various embodiments, the MCS device is configured to be powered by one of the receiver, the battery, or a combination thereof. In various embodiments, the system further includes an implantable controller.

20 [00015] Another aspect of the present invention is directed to a method of using the system, and in particular the receiver. In various respects the invention is directed to wirelessly transmitting energy comprising energizing a transmitter to generate a magnetic field, and positioning the receiver in the magnetic field to induce a voltage in the receiver coil. In various
25 embodiments, the method includes positioning the receiver in a mammalian body. In various embodiments, the method includes positioning the receiver in a patient suffering from heart failure, cardiogenic shock, or undergoing high risk surgery (e.g. percutaneous coronary intervention). In various embodiments, the method includes positioning the receiver in the chest cavity of a human.

[00016] The receiver and wireless energy transmission system of the various inventions have
30 other features and advantages which will be apparent from or are set forth in more detail in the accompanying drawings, which are incorporated in and form a part of this specification, and the following Detailed Description of the Invention, which together serve to explain the principles of the present invention.

[00017] An implantable receiver configured to receive wireless energy is provided,
35 comprising a housing including internal components susceptible to interference by magnetic

flux, a covering disposed on at least a portion of the housing, the covering being formed of a ferrite material configured to both magnetically shield a respective portion of components in the housing and redirect incoming magnetic flux from an external transmitter, at least two wires wrapped around the housing to form a receiver coil.

5 [00018] In some embodiments, the internal components of the receiver comprise receiver circuitry configured to transmit power excited in the receiver coil in response to the incoming magnetic flux to a load connected to the implantable receiver.

[00019] In other embodiments, the load is an implantable medical device including an operative component.

10 [00020] In some embodiments, the operative component is a circulatory support device.

[00021] In another embodiment, the operative component is a blood pump.

[00022] In some embodiments, the covering comprises a plurality of tiles.

[00023] In another embodiment, the covering covers the entire housing periphery.

[00024] In some embodiments, the covering is configured to redirect incoming magnetic flux
15 from the external transmitter towards the receiver coil to improve power transfer efficiency.

[00025] A method of improving efficiency in a wireless power transfer system is also provided, comprising the steps of generating magnetic flux with an external transmitter positioned near a patient towards a receiver implanted in the patient, and directing the magnetic flux towards a receiver coil of the receiver with a ferrite covering that surrounds at least a portion
20 of the receiver.

[00026] In one embodiment, the covering comprises a plurality of ferrite tiles.

BRIEF DESCRIPTION OF THE DRAWINGS

25 [00027] The novel features of the invention are set forth with particularity in the claims that follow. A better understanding of the features and advantages of the present invention will be obtained by reference to the following detailed description that sets forth illustrative embodiments, in which the principles of the invention are utilized, and the accompanying drawings of which:

30 [00028] FIG. 1 is a schematic of a simplified circuit for wireless energy transmission system in accordance with various aspects of the invention.

[00029] FIG. 2 is a simplified schematic illustrating the relationship between the transmitter and receiver coil sizes and coupling coefficient.

[00030] FIG. 3A is a schematic of a transmitter and receiver in operation, the receiver being at
35 an angle θ relative to the transmitter. FIG. 3B is a schematic of the transmitter and receiver

of FIG. 3A, the receiver being aligned with the transmitter by translated in an axial position so the receiver and transmitter are offset. In FIG. 3B, half the flux from one coil is in one direction, and the other half is in the other direction.

[00031] FIG. 4 is a perspective view of a receiver housing in accordance with various aspects
5 of the invention.

[00032] FIG. 5 is a cross-sectional, schematic view of an exemplary receiver positioned in a magnetic field.

[00033] FIG. 6 is a cross-sectional, schematic view of an exemplary receiver positioned in a magnetic field, the receiver including a ferrite covering in accordance with various aspects of the
10 invention.

[00034] FIG. 7 is a cross-sectional, schematic view of the receiver of FIG. 5, illustrating the receiver turned at an angle θ .

[00035] FIG. 8 is a cross-sectional, schematic view of the receiver of FIG. 6, illustrating the receiver turned at an angle θ .

[00036] FIG. 9 is a cross-sectional, schematic view of the receiver of FIG. 6, illustrating the
15 receiver turned at an angle θ_C .

[00037] FIG. 10 is a graph illustrating efficiency of two receivers A and B at varying angles θ , receiver A having a ferrite covering and receiver B without a ferrite covering.

[00038] FIG. 11 is a cross-sectional, schematic view of an exemplary receiver, the receiver
20 including a continuous ferrite covering in accordance with various aspects of the invention.

DETAILED DESCRIPTION

[00039] In the description that follows, like components have been given the same reference numerals, regardless of whether they are shown in different embodiments. To illustrate an
25 embodiment(s) of the present disclosure in a clear and concise manner, the drawings may not necessarily be to scale and certain features may be shown in somewhat schematic form. Features that are described and/or illustrated with respect to one embodiment may be used in the same way or in a similar way in one or more other embodiments and/or in combination with or instead of the features of the other embodiments.

[00040] Various aspects of the invention are similar to those described in International Patent
30 Pub. No. WO2012045050; U.S. Patent Nos. 8,140,168; 7,865,245; 7,774,069; 7,711,433; 7,650,187; 7,571,007; 7,741,734; 7,825,543; 6,591,139; 6,553,263; and 5,350,413; and U.S. Pub. Nos. 2010/0308939; 2008/027293; and 2010/0102639, the entire contents of which patents and applications are incorporated herein for all purposes.

Wireless Power Transmission System

[00041] Power may be transmitted wirelessly by magnetic induction. In various embodiments, the transmitter and receiver are closely coupled.

[00042] In some cases “closely coupled” or “close coupling” refers to a system that requires the coils to be very near each other in order to operate. In some cases “loosely coupled” or “loose coupling” refers to a system configured to operate when the coils have a significant spatial and/or axial separation, and in some cases up to distance equal to or less than the diameter of the larger of the coils. In some cases, “loosely coupled” or “loose coupling” refers a system that is relatively insensitive to changes in physical separation and/or orientation of the receiver and transmitter.

[00043] In various embodiments, the transmitter and receiver are non-resonant coils. For example, a change in current in one coil induces a changing magnetic field. The second coil within the magnetic field picks up the magnetic flux, which in turn induces a current in the second coil. An example of a closely coupled system with non-resonant coils is described in International Pub. No. WO2000/074747, incorporated herein for all purposes by reference. A conventional transformer is another example of a closely coupled, non-resonant system. In various embodiments, the transmitter and receiver are resonant coils. For example, one or both of the coils is connected to a tuning capacitor or other means for controlling the frequency in the respective coil. An example of closely coupled system with resonant coils is described in International Pub. Nos. WO2001/037926; WO2012/087807; WO2012/087811; WO2012/087816; WO2012/087819; WO2010/030378; and WO2012/056365, and U.S. Pub. No. 2003/0171792, incorporated herein for all purposes by reference.

[00044] In various embodiments, the transmitter and receiver are loosely coupled. For example, the transmitter can resonate to propagate magnetic flux that is picked up by the receiver at relatively great distances. In some cases energy can be transmitted over several meters. In a loosely coupled system power transfer may not necessarily depend on a critical distance. Rather, the system may be able to accommodate changes to the coupling coefficient between the transmitter and receiver. An example of a loosely coupled system is described in International Pub. No. WO2012/045050, incorporated herein for all purposes by reference.

[00045] Power may be transmitted wirelessly by radiating energy. In various embodiments, the system comprises antennas. The antennas may be resonant or non-resonant. For example, non-resonant antennas may radiate electromagnetic waves to create a field. The field can be near field or far field. The field can be directional. Generally far field has greater range but a lower power transfer rate. An example of such a system for radiating energy with resonators is described in International Pub. No. WO2010/089354, incorporated herein for all purposes by

reference. An example of such a non-resonant system is described in International Pub. No. WO2009/018271, incorporated herein for all purposes by reference. Instead of antenna, the system may comprise a high energy light source such as a laser. The system can be configured so photons carry electromagnetic energy in a spatially restricted, direct, coherent path from a transmission point to a receiving point. An example of such a system is described in

5 [00046] Power may also be transmitted by taking advantage of the material or medium through which the energy passes. For example, volume conduction involves transmitting electrical energy through tissue between a transmitting point and a receiving point. An example of such a system is described in International Pub. No. WO2008/066941, incorporated herein for all purposes by reference.

10 [00047] Power may also be transferred using a capacitor charging technique. The system can be resonant or non-resonant. Exemplars of capacitor charging for wireless energy transfer are described in International Pub. No. WO2012/056365, incorporated herein for all purposes by

15 reference. [00048] The system in accordance with various aspects of the invention will now be described in connection with a system for wireless energy transfer by magnetic induction. The exemplary system utilizes resonant power transfer. The system works by transmitting power between the two inductively coupled coils. In contrast to a transformer, however, the exemplary coils are not coupled together closely. A transformer generally requires the coils to be aligned and positioned directly adjacent each other. The exemplary system accommodates looser coupling of the coils.

20 [00049] While described in terms of one receiver coil and one transmitter coil, one will appreciate from the description herein that the system may use two or more receiver coils and two or more transmitter coils. For example, the transmitter may be configured with two coils—a first coil to resonate flux and a second coil to excite the first coil. One will further appreciate from the description herein that usage of “resonator” and “coil” may be used somewhat interchangeably. In various respects, “resonator” refers to a coil and a capacitor connected together.

25 [00050] In accordance with various embodiments of this disclosure, the system comprises one or more transmitters configured to transmit power wirelessly to one or more receivers. In various embodiments, the system includes a transmitter and more than one receiver in a multiplexed arrangement. A frequency generator may be electrically coupled to the transmitter to drive the transmitter to transmit power at a particular frequency or range of frequencies. The frequency generator can include a voltage controlled oscillator and one or more switchable

35 arrays of capacitors, a voltage controlled oscillator and one or more varactors, a phase-locked-

loop, a direct digital synthesizer, or combinations thereof. The transmitter can be configured to transmit power at multiple frequencies simultaneously. The frequency generator can include two or more phase-locked-loops electrically coupled to a common reference oscillator, two or more independent voltage controlled oscillators, or combinations thereof. The transmitter can be

5 arranged to simultaneously delivery power to multiple receivers at a common frequency.

[00051] In various embodiments, the transmitter is configured to transmit a low power signal at a particular frequency. The transmitter may transmit the low power signal for a particular time and/or interval. In various embodiments, the transmitter is configured to transmit a high power signal wirelessly at a particular frequency. The transmitter may transmit the high power signal

10 for a particular time and/or interval.

[00052] In various embodiments, the receiver includes a frequency selection mechanism electrically coupled to the receiver coil and arranged to allow the resonator to change a frequency or a range of frequencies that the receiver can receive. The frequency selection mechanism can include a switchable array of discrete capacitors, a variable capacitance, one or

15 more inductors electrically coupled to the receiving antenna, additional turns of a coil of the receiving antenna, or combinations thereof.

[00053] In general, most of the flux from the transmitter coil does not reach the receiver coil. The amount of flux generated by the transmitter coil that reaches the receiver coil is described by “k” and referred to as the “coupling coefficient.”

[00054] In various embodiments, the system is configured to maintain a value of k in the range of between about 0.2 to about 0.01. In various embodiments, the system is configured to maintain a value of k of at least 0.01, at least 0.02, at least 0.03, at least 0.04, or at least 0.05.

[00055] In various embodiments, the coils are physically separated. In various embodiments, the separation is greater than a thickness of the receiver coil. In various embodiments, the

25 separation distance is equal to or less than the diameter of the larger of the receiver and transmitter coil.

[00056] Because most of the flux does not reach the receiver, the transmitter coil must generate a much larger field than what is coupled to the receiver. In various embodiments, this is accomplished by configuring the transmitter with a large number of amp-turns in the coil.

[00057] Since only the flux coupled to the receiver gets coupled to a real load, most of the energy in the field is reactive. The current in the coil can be sustained with a capacitor connected to the coil to create a resonator. The power source thus only needs to supply the energy absorbed by the receiver. The resonant capacitor maintains the excess flux that is not

30 coupled to the receiver.

[00058] In various embodiments, the impedance of the receiver is matched to the transmitter. This allows efficient transfer of energy out of the receiver. In this case the receiver coil may not need to have a resonant capacitor.

[00059] Turning now to Fig. 1, a simplified circuit for wireless energy transmission is shown.

5 The exemplary system shows a series connection, but the system can be connected as either series or parallel on either the transmitter or receiver side.

[00060] The exemplary transmitter includes a coil L_x connected to a power source V_s by a capacitor C_x . The exemplary receiver includes a coil L_y connected to a load by a capacitor C_y . Capacitor C_x may be configured to make L_x resonate at a desired frequency. Capacitance C_x of
10 the transmitter coil may be defined by its geometry. Inductors L_x and L_y are connected by coupling coefficient k . M_{xy} is the mutual inductance between the two coils. The mutual inductance, M_{xy} , is related to coupling coefficient, k .

$$[00061] \quad M_{xy} = k\sqrt{L_x \cdot L_y}$$

[00062] In the exemplary system the power source V_s is in series with the transmitter coil L_x
15 so it may have to carry all the reactive current. This puts a larger burden on the current rating of the power source and any resistance in the source will add to losses.

[00063] The exemplary system includes a receiver configured to receive energy wirelessly transmitted by the transmitter. The exemplary receiver is connected to a load. The receiver and load may be connected electrically with a controllable switch.

20 [00064] In various embodiments, the receiver includes a circuit element configured to be connected or disconnected from the receiver coil by an electronically controllable switch. The electrical coupling can include both a serial and parallel arrangement. The circuit element can include a resistor, capacitor, inductor, lengths of an antenna structure, or combinations thereof. The system can be configured such that power is transmitted by the transmitter and can be
25 received by the receiver in predetermined time increments.

[00065] In various embodiments, the transmitter coil and/or the receiver coil is a substantially two-dimensional structure. In various embodiments, the transmitter coil may be coupled to a transmitter impedance-matching structure. Similarly, the receiver coil may be coupled to a receiver impedance-matching structure. Examples of suitable impedance-matching structures
30 include, but are not limited to, a coil, a loop, a transformer, and/or any impedance-matching network. An impedance-matching network may include inductors or capacitors configured to connect a signal source to the resonator structure.

[00066] In various embodiments, the transmitter is controlled by a controller (not shown) and driving circuit. The controller and/or driving circuit may include a directional coupler, a signal
35 generator, and/or an amplifier. The controller may be configured to adjust the transmitter

frequency or amplifier gain to compensate for changes to the coupling between the receiver and transmitter.

[00067] In various embodiments, the transmitter coil is connected to an impedance-matched coil loop. The loop is connected to a power source and is configured to excite the transmitter coil. The first coil loop may have finite output impedance. A signal generator output may be amplified and fed to the transmitter coil. In use power is transferred magnetically between the first coil loop and the main transmitter coil, which in turns transmits flux to the receiver. Energy received by the receiver coil is delivered by Ohmic connection to the load.

[00068] One of the challenges to a practical circuit is how to get energy in and out of the resonators. Simply putting the power source and load in series or parallel with the resonators is difficult because of the voltage and current required. In various embodiments, the system is configured to achieve an approximate energy balance by analyzing the system characteristics, estimating voltages and currents involved, and controlling circuit elements to deliver the power needed by the receiver.

[00069] In an exemplary embodiment, the system load power, P_L , is assumed to be 15 Watts and the operating frequency of the system, f , is 250 kHz. Then, for each cycle the load removes a certain amount of energy from the resonance:

[00070] $e_L = \frac{P_L}{f} = 60\mu J$ *Energy the load removes from one cycle*

$$e_L = \frac{P_L}{f} = 60\mu J \quad \text{Energy the load removes in one cycle}$$

[00071]

[00072] It has been found that the energy in the receiver resonance is typically several times larger than the energy removed by the load for operative, implantable medical devices. In various embodiments, the system assumes a ratio 7:1 for energy at the receiver versus the load removed. Under this assumption, the instantaneous energy in the exemplary receiver resonance is 420 μJ .

[00073] The exemplary circuit was analyzed and the self inductance of the receiver coil was found to be 60 μH . From the energy and the inductance, the voltage and current in the resonator could be calculated.

[00074] $e_y = \frac{1}{2} L i^2$

[00075] $i_y = \sqrt{\frac{2e_y}{L}} = 3.74A \text{ peak}$

[00076] $v_y = \omega L_y i_y = 352V \text{ peak}$

[00077] The voltage and current can be traded off against each other. The inductor may couple the same amount of flux regardless of the number of turns. The Amp-turns of the coil

needs to stay the same in this example, so more turns means the current is reduced. The coil voltage, however, will need to increase. Likewise, the voltage can be reduced at the expense of a higher current. The transmitter coil needs to have much more flux. The transmitter flux is related to the receiver flux by the coupling coefficient. Accordingly, the energy in the field from the transmitter coil is scaled by k.

$$[00078] \quad e_x = \frac{e_y}{k}$$

[00079] Given that k is 0.05:

$$[00080] \quad e_x = \frac{420 \mu J}{0.05} = 8.4 mJ$$

[00081] For the same circuit the self inductance of the transmitter coil was 146uH as

10 mentioned above. This results in:

$$[00082] \quad i_x = \sqrt{\frac{2e_x}{L}} = 10.7 A \text{ peak}$$

$$[00083] \quad v_x = \omega L_x i_x = 2460 V \text{ peak}$$

[00084] One can appreciate from this example, the competing factors and how to balance voltage, current, and inductance to suit the circumstance and achieve the desired outcome. Like the receiver, the voltage and current can be traded off against each other. In this example, the voltages and currents in the system are relatively high. One can adjust the tuning to lower the voltage and/or current at the receiver if the load is lower.

Estimation of Coupling Coefficient and Mutual Inductance

20 [00085] As explained above, the coupling coefficient, k, may be useful for a number of reasons. In one example, the coupling coefficient can be used to understand the arrangement of the coils relative to each other so tuning adjustments can be made to ensure adequate performance. If the receiver coil moves away from the transmitter coil, the mutual inductance will decrease, and ceteris paribus, less power will be transferred. In various embodiments, the system is configured to make tuning adjustments to compensate for the drop in coupling efficiency.

[00086] The exemplary system described above often has imperfect information. For various reasons as would be understood by one of skill in the art, the system does not collect data for all parameters. Moreover, because of the physical gap between coils and without an external means of communications between the two resonators, the transmitter may have information that the receiver does not have and vice versa. These limitations make it difficult to directly measure and derive the coupling coefficient, k, in real time.

[00087] Described below are several principles for estimating the coupling coefficient, k, for two coils of a given geometry. The approaches may make use of techniques such as Biot-Savart

calculations or finite element methods. Certain assumptions and generalizations, based on how the coils interact in specific orientations, are made for the sake of simplicity of understanding. From an electric circuit point of view, all the physical geometry permutations can generally lead to the coupling coefficient.

5 [00088] If two coils are arranged so they are in the same plane, with one coil circumscribing the other, then the coupling coefficient can be estimated to be roughly proportional to the ratio of the area of the two coils. This assumes the flux generated by coil 1 is roughly uniform over the area it encloses as shown in Fig. 2.

[00089] If the coils are out of alignment such that the coils are at a relative angle, the coupling coefficient will decrease. The amount of the decrease is estimated to be about equal to the cosine of the angle as shown in Fig. 3A. If the coils are orthogonal to each other such that theta (θ) is 90 degrees, the flux will not be received by the receiver and the coupling coefficient will be zero.

10 [00090] If the coils are arranged such that half the flux from one coil is in one direction and the other half is in the other direction, the flux cancels out and the coupling coefficient is zero, as shown in Fig. 3B.

[00091] A final principle relies on symmetry of the coils. The coupling coefficient and mutual inductance from one coil to the other is assumed to be the same regardless of which coil is being energized.

15 [00092] $M_{xy} = M_{yx}$

20 Wireless Power Transmission System

[00093] For reasons that will be apparent to one of skill from the description herein, even minor influences on the system from external factors can lead to significant changes in the system operation. For example, the introduction of metal to the field can significantly affect the coupling coefficient and mutual inductance.

25 [00094] One way to ensure the system operates effectively is to design the system without consideration of environmental factors and utilize magnetic shielding to isolate the system from external influences. For example, the computer field makes ample use of magnetic shielding to isolate sensitive components within the system.

[00095] In one embodiment, the transmitter transmits energy across a specified volume in which the receiver is positioned. The receiver typically includes components that can be negatively affected by the transmitter flux. In various embodiments, the system includes magnetic shielding to isolate the electronic components associated with the receiver coil from interference by the transmitter.

30 [00096] With reference generally to FIGS. 4-6, one embodiment includes a structure for two purposes—magnetically shielding components within the receiver enclosure from the transmitter

and adjusting the path of the flux lines otherwise passing through the enclosure. The system can provide several advantages over existing systems. The use of a single structure for magnetic shielding and focusing and/or redirecting flux provides a simple and effective solution. The system eliminates the need for two or more structures. This is critical for implantable devices
5 where the form factor, and reducing both the size and weight of the implant, is of utmost importance. In some cases, the elimination of redundant structures provides greater flexibility of placement, positioning, and surgical implantation procedures. The relatively simple design also reduces the cost of goods sold (COGS) and provides other technical advantages like reduced risk of failure and easier manufacturability.

10 [00097] FIG. 4 shows a receiver generally designated 20. The receiver 20 can be, for example, an implantable receiver of a TET system and can be configured to receive wireless power from an external transmitter of the TET system. The receiver can include a receiver coil and electronics enclosed within a housing 25. Although these components are not shown in Fig. 4, a schematic representation of the receiver circuitry can be found in FIG. 1. The housing may
15 be hermetically sealed. The housing may be fluid tight. The receiver can include, but is not necessarily limited to, a receiver circuit, tuning circuit, signal processing circuit, power source (e.g. batteries, such as lithium-ion batteries), and controls (none of which are shown in FIG. 4). The receiver can also include a number of wire turns that may be all in one solenoidal layer or distributed over multiple layers.

20 [00098] The housing 25 includes an enclosure covered with a covering 40 formed of magnetically susceptible material. In an exemplary embodiment, the housing is formed of a metal and the covering is formed of ferrite. The housing may be formed of a variety of materials. The covering does not need to be formed of a purely ferrite materials. In various embodiments, the housing is covered in a ferrite-based material and/or alloy. As used herein,
25 “ferrite” refers to materials with a significant ferrimagnetic or ferromagnetic component (percent by weight).

[00099] In one embodiment, the covering 40 of housing 25 comprises a plurality of ferrite tiles 41. One will appreciate that the housing may be only partially covered in other
30 embodiments. The tiles may all be of a uniform size, or may be of different sizes. In the embodiment shown in FIG. 4, the tiles 41 on the top/bottom portions 30 of the housing 25 can be, for example, rectangular. The tiles 41 on the sides 33 of the housing 25 can be, alternatively, square shaped. It should be understood that any number of shape of tiles can be used to cover the housing 25. For example, a tile could be custom manufactured to precisely cover one face of the housing. Also referring to FIG. 4, there may exist small gaps 35 between the ferrite tiles 41,
35 particularly near the edges of the housing. These gaps can be minimized or eliminating by

arranging the tiles 41 on one side of the enclosure (e.g., top/bottom portion 30) so as to overlap the edges of the tiles 41 on the adjacent side of the enclosure (e.g., side 33).

[000100] The surface area of the housing that is covered may depend upon design goals and expected use. The thickness of the exemplary ferrite tiles is sufficient such that the

5 magnetization of the ferrite is not saturated. In many implementations, the ferrite is far from saturation, and the thickness is instead chosen to be practical during manufacture, e.g., the ferrite tiles are not so thin that they could easily crack or break apart during the assembly process.

[000101] Housing 25 is intended to be wrapped with windings to form receiver 20. In various embodiments, the housing is wrapped end-to-end with Litz wires. The housing may have a
10 plurality of turns, for example, 5 turns, 10 turns, 15 turns, 20 turns, 25 turns, or more.

[000102] FIGS. 5 and 6 illustrate use of two different receiver configurations in accordance with various aspects of the invention. FIG. 5 is a cross-sectional schematic representation of a receiver without a ferrite covering. FIG. 6 is a cross-sectional schematic representation of a receiver with a ferrite covering similar to FIG. 4.

15 [000103] FIG. 5 illustrates interaction of a receiver 10 with flux lines when it is introduced into a field of the transmitter (e.g., the transmitter of FIG. 1). Receiver 10 includes a housing 13 without a ferrite covering. Flux lines F1, F2, F3, and F4 are presented to receiver 20. Lines F1 and F2 pass through a front face and exit out a back face of the receiver. Lines F1 and F2 induce a good electromagnetic force (voltage) in the receiver coil. Lines F1 and F2 are said to be
20 efficient because they are picked up by all the windings. Line F3 passes through the front face and out the sidewall. F3 is relatively efficient in that it is picked up by most of the windings. In the illustrated embodiment, for example, voltage is induced in about half the windings. Line F4 presents a more significant problem. Line F4 passes through the front face and out the front edge of sidewall such that it only passes through a small percentage of the turns. In the case of
25 FIG. 5, line F4 induces a voltage in only one or two turns.

[000104] Turning to FIG. 6, a receiver 20 including a housing 25 a ferrite covering 40. The ferrite-covered housing can be wrapped with wires 22 in a plurality of turns.

[000105] In contrast to receiver 10 of FIG. 5, receiver 20 in FIG. 6 more efficiently translates the flux lines into an induced voltage. Receiver 20 also shields the components inside housing
30 25 from interference by the magnetic field lines.

[000106] Lines F1' and F2' induce a voltage in all the wires similar to the example of FIG. 5. Unlike the structure above, however, lines F3' and F4' create larger voltages in the receiving coil than similar lines F3 and F4 with receiver 10. Line F3' hits housing 25 along a front face. The magnetic properties of the material cause the energy to travel from the point of impact along the
35 front face and sidewall and exit somewhere further past the turns. This is in contrast to the

example of F3 where the line travels directly through the structure. In the example of FIG. 6, the line is picked up by most of the turns whereas without the ferrite covering shown in FIG. 5 the same line would only be picked up by about half the turns. Similarly, line F4' is picked up by a larger number of the turns than would be the case with the structure of FIG. 5. In turn, ceteris paribus, a greater voltage is created when the receiver is introduced to the same field. The structure is thus said to be more efficient. Efficiency is represented herein as η (eta).

[000107] The improved efficiency of receiver 20 is more pronounced as the angle θ (theta) of the receiver changes relative to the transmitter. FIGS. 7 and 8 illustrate how the same flux lines are redirected using the ferrite covering to improve efficiency. FIG. 7 shows the same receiver 10 of FIG. 5 except the receiver has been rotated at an angle θ . In this exemplary case lines F2a, F3a, and F4a all pass through the interior of the receiver housing and out a sidewall. Thus, the efficiency is diminished for these lines and the lines also interfere with the internal components. By contrast, receiver 20 of FIG. 8 generates more voltage in the same field and reduces or eliminates interference with internal components. Lines F2a', F3a', and F4a' are all guided around the housing periphery and are transferred away from the housing further back along the windings as line F.

[000108] With the receiver 20 making use of a covering 40, the improvements in efficiency may be lost at a particular critical angle, θ_c . FIG. 9 shows receiver 20 at an angle θ_c . In the illustrated embodiment, line F3' passes through one sidewall and out another sidewall. Indeed, more lines enter the first sidewall than the front face because of the steep angle. In other words, the surface area in a plane parallel the transmitter is larger for the sidewall than the front face. At angles beyond θ_c , some field lines are redirected by the ferrite so that they are picked up by fewer turns than in a receiver without ferrite.

[000109] FIG. 10 is a graph illustrating the effect described above with respect to FIGS. 5-9. Line A illustrates data obtained using a structure similar to that of receiver 20, with a ferrite covering. Line A illustrates data obtained using a structure similar to that of receiver 10, without the covering. The graph illustrates that when the receiver and transmitter are perfectly aligned (i.e. parallel) the efficiency of receiver 20 is slightly higher. In one case the efficiency was found to be about 0.5% higher.

[000110] Moving along the curves, the efficiency of receiver 20 remains high over a far wider range of angles than receiver 10. This is shown by the flatter section of line A versus the declining slope of line B. At some angle there is an inflection point where the slope of line A rapidly changes. This effect is described above with respect to FIG. 9. Slightly beyond this angle lines A and B intersect and the structure of receiver 10 becomes more efficient.

[000111] Lines A and B approach the x-axis, theta, at different points. This shows that the efficiency of receiver 20 drops to zero at a smaller angle than receiver 10.

[000112] FIG. 11 shows a receiver 200 similar to receiver 20 except the covering is formed of a material that coats the housing. The material defines a covering 240 around a housing 225 and wrapped by wire turns 222. Covering 240 may be formed by dip coating or similar processes. The exemplary covering does not include gaps as would be present with tiles. Moreover, the covering 240 can be relatively thicker than covering 40.

[000113] One will appreciate from the description herein how to select the components to optimize performance based on a particular application. In various embodiments, the receiver can be configured to make use of the flat section of line A. For example, the receiver can be configured such that the critical angle, θ_C , is greater than the largest angle expected to be seen in practice. In this manner the receiver will operate efficiently across the entire operational range of angles. In another example, the inflection point may be used such that little or no voltage is induced beyond a certain angle. The system could recognize a sharp drop in voltage and perform an action (e.g. generate an alarm or fault code). For example, the system can send an audible or visible alarm to the user that the coils are drastically out of alignment.

[000114] One aspect of the disclosure is directed to an implantable receiver for wirelessly receiving energy from a transmitter, including a housing enclosing volume including a receiving coil and components susceptible to interference by magnetic flux; a covering around at least a portion of the housing; at least one wire wrapped around the housing to form a plurality of turns; wherein the covering is formed of a ferrite material configured to both magnetically shield a respective portion of the internal volume and redirect incoming magnetic flux.

[000115] In various embodiments, the receiver includes coil circuitry including at least two coils; and receiver circuitry configured to transmit power excited in the receiver coil in response to exposure to a field to a load. In various embodiments, the load is an implantable medical device including an operative component. The operative component may be a circulatory support device. The operative component may be a blood pump for supporting and/or replacing the function of the heart. The operative component may be a left ventricular assist device, right ventricular assist device, bi-ventricular assist device, and/or total artificial heart. All or part of the operative component may be external to the body.

[000116] In various embodiments, the covering comprises a plurality of tiles. In various embodiments, the covering covers the entire housing periphery.

[000117] Various aspects of the invention are directed to a system including a receiver, a transmitter for generating a magnetic field to the receiver, and an implantable mechanical circulatory support (MCS) device. In various embodiments, the MCS device is configured to be

powered by energy from the receiver. In various embodiments, the system further includes an implantable battery. In various embodiments, the MCS device is configured to be powered by one of the receiver, the battery, or a combination thereof. In various embodiments, the system further includes an implantable controller.

5 [000118] Another aspect of the disclosure is directed to a method of using the system, and in particular the receiver. In various respects the disclosure is directed to wirelessly transmitting energy comprising energizing a transmitter to generate a magnetic field, and positioning the receiver in the magnetic field to induce a voltage in the receiver coil. In various embodiments, the method includes positioning the receiver in a mammalian body. In various embodiments, the method includes positioning the receiver in a patient suffering from heart failure, cardiogenic shock, or undergoing high risk surgery (e.g. percutaneous coronary intervention). In various
10 embodiments, the method includes positioning the receiver in the chest cavity of a human.

[000119] One will appreciate from the description herein that the configuration of the covering may be modified to improve performance. For example, only a portion of the housing may be covered with ferrite material to achieve a desired efficiency-angle curve. In one example, only a
15 portion of the housing is covered based on what part of the housing is desired to be magnetically shielded. These and many other modifications are within the spirit of the inventions.

[000120] The foregoing descriptions of specific embodiments of the present invention have been presented for purposes of illustration and description. They are not intended to be
20 exhaustive or to limit the invention to the precise forms disclosed, and obviously many modifications and variations are possible in light of the above teaching. The embodiments were chosen and described in order to best explain the principles of the invention and its practical application, to thereby enable others skilled in the art to best utilize the invention and various embodiments with various modifications as are suited to the particular use contemplated. It is
25 intended that the scope of the invention be defined by the Claims appended hereto and their equivalents.

CLAIMS

What is claimed is:

- 5 1. An implantable receiver configured to receive wireless energy, comprising:
 a housing including internal components susceptible to interference by magnetic flux;
 a covering disposed on at least a portion of the housing, the covering being formed of a
 ferrite material configured to both magnetically shield a respective portion of components in the
 housing and redirect incoming magnetic flux from an external transmitter;
 at least two wires wrapped around the housing to form a receiver coil.
10
2. The receiver of claim 1, wherein the internal components of the receiver comprise
 receiver circuitry configured to transmit power excited in the receiver coil in response to the
 incoming magnetic flux to a load connected to the implantable receiver.
- 15 3. The receiver of claim 2, wherein the load is an implantable medical device
 including an operative component.
4. The receiver of claim 3, wherein the operative component is a circulatory support
 device.
20
5. The receiver of claim 3, wherein the operative component is a blood pump.
6. The receiver of claim 1, wherein the covering comprises a plurality of tiles.
- 25 7. The receiver of claim 1, wherein the covering covers the entire housing periphery.
8. The receiver of claim 1, wherein the covering is configured to redirect incoming
 magnetic flux from the external transmitter towards the receiver coil to improve power transfer
 efficiency.
30
9. A method of improving efficiency in a wireless power transfer system,
 comprising the steps of:
 generating magnetic flux with an external transmitter positioned near a patient towards a
 receiver implanted in the patient;

directing the magnetic flux towards a receiver coil of the receiver with a ferrite covering that surrounds at least a portion of the receiver.

10. The method of claim 9 wherein the covering comprises a plurality of ferrite tiles.

5

Fig. 1

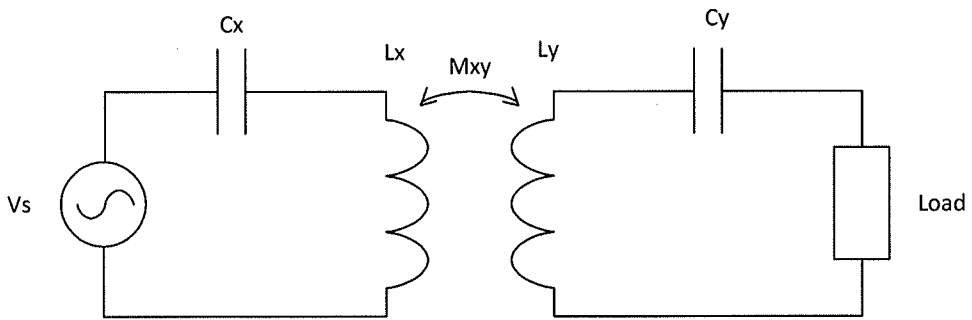

Fig. 2

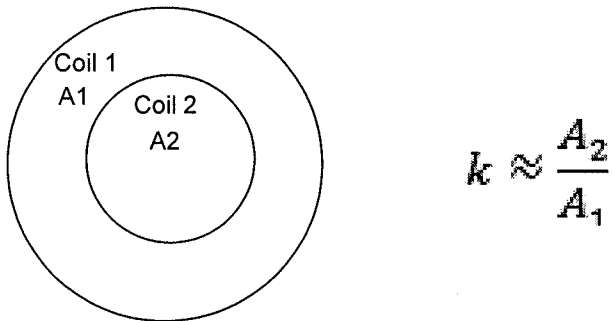

Fig. 3A

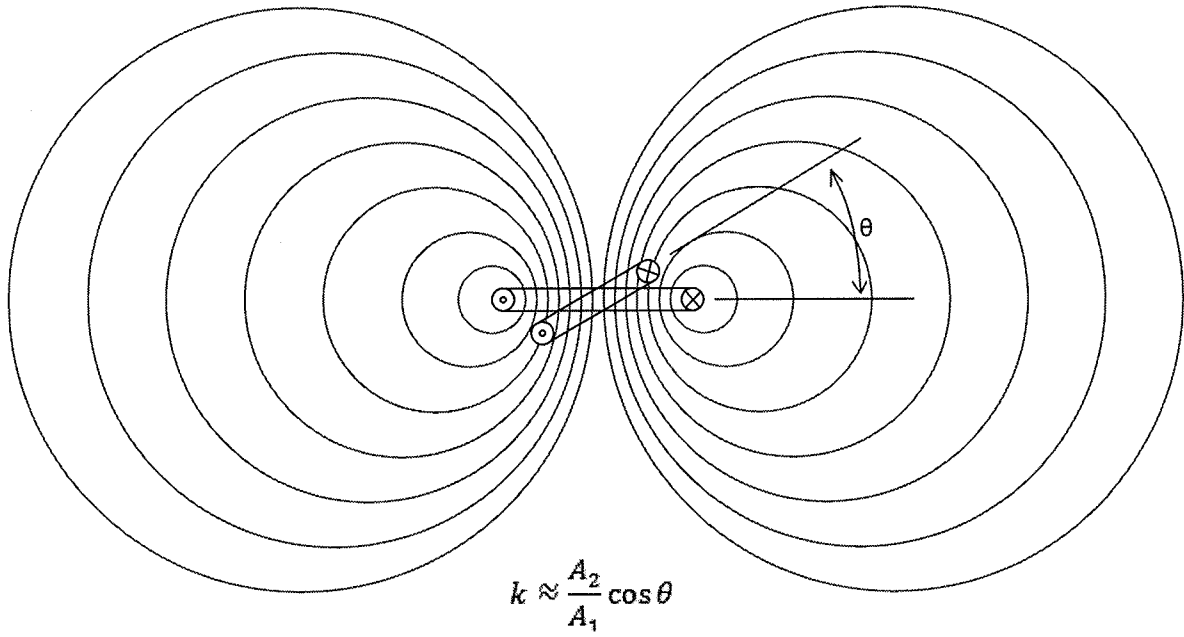

Fig. 3B

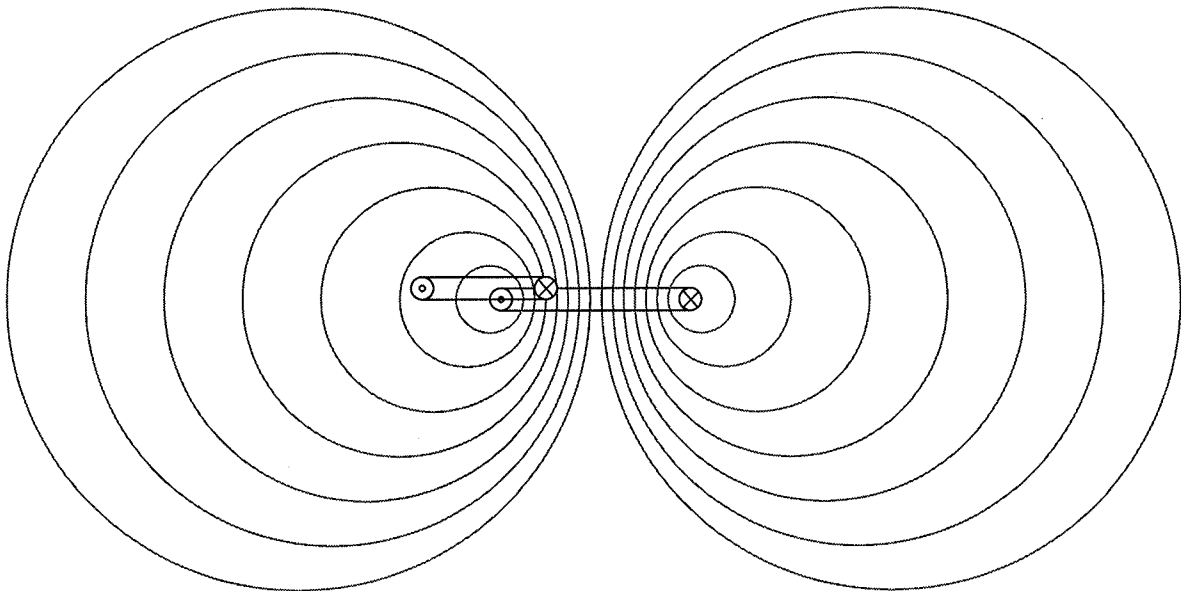
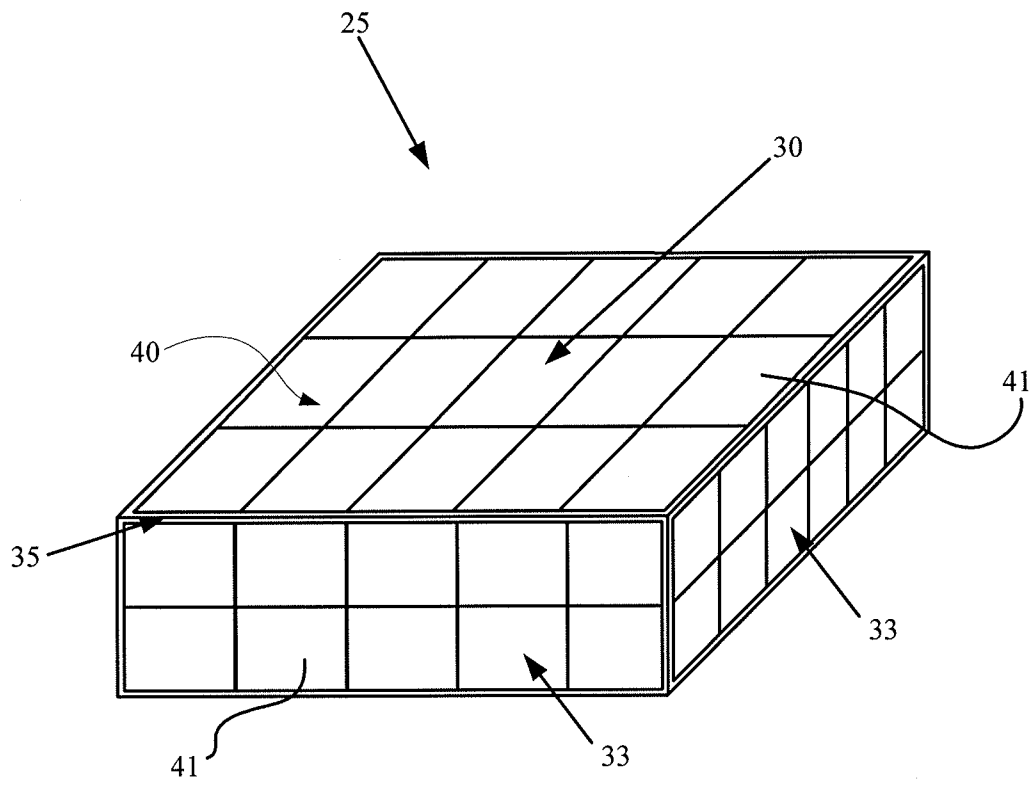

Fig. 4



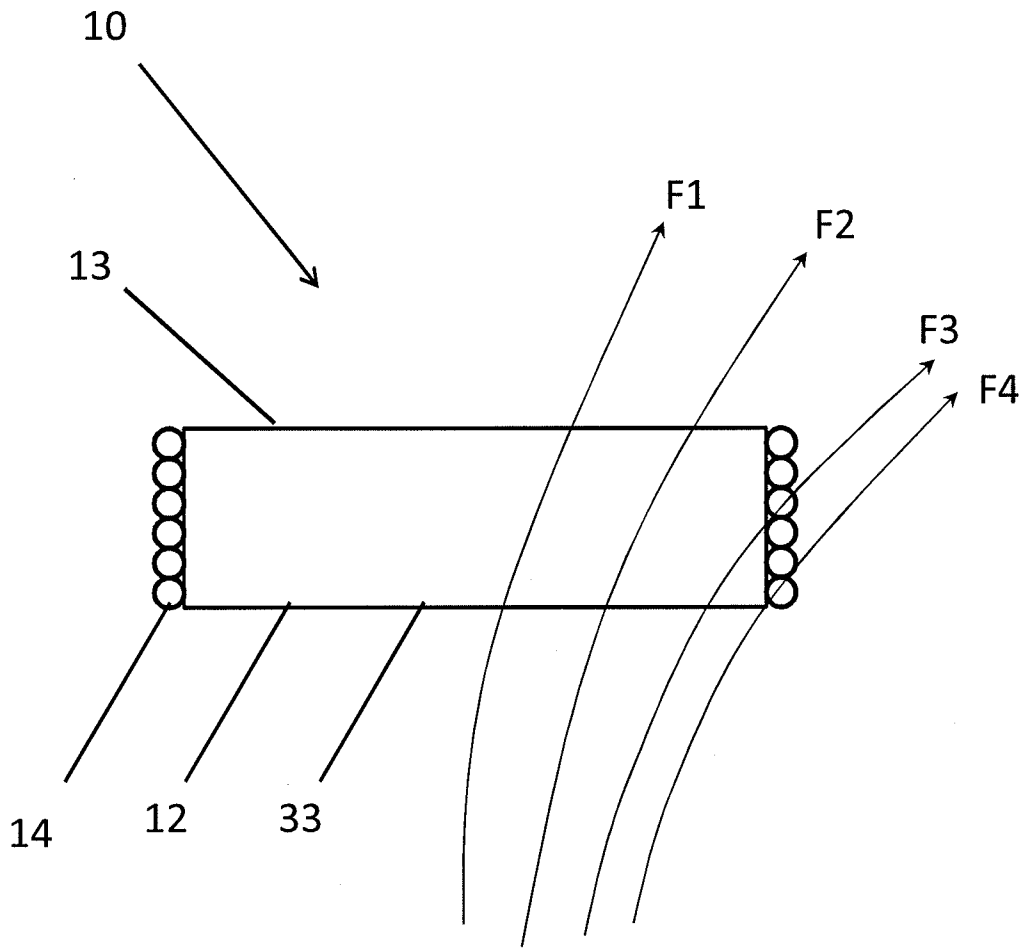

FIG. 5

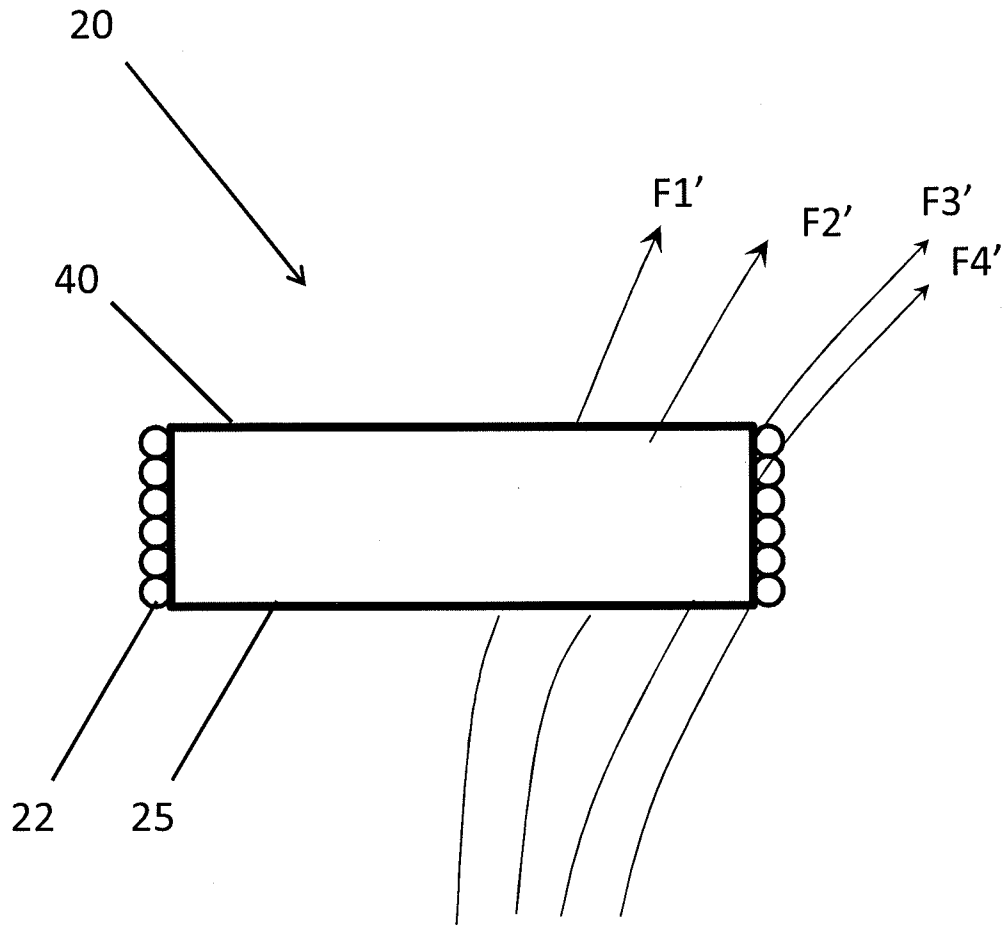

FIG. 6

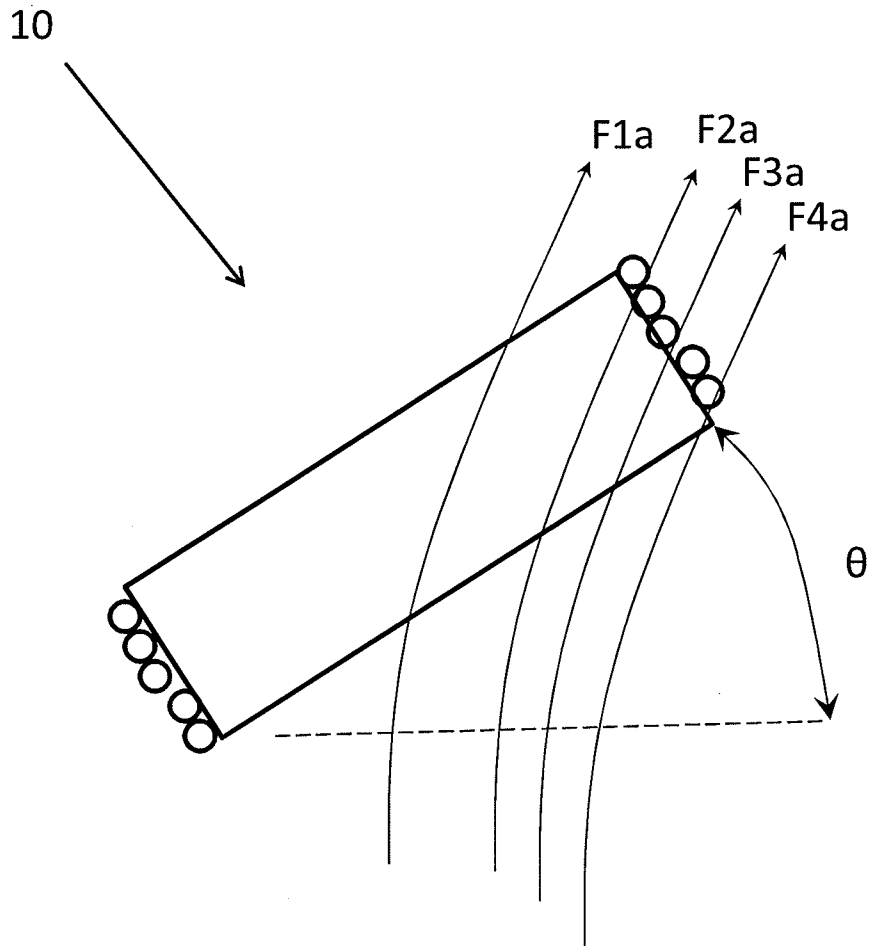

FIG. 7

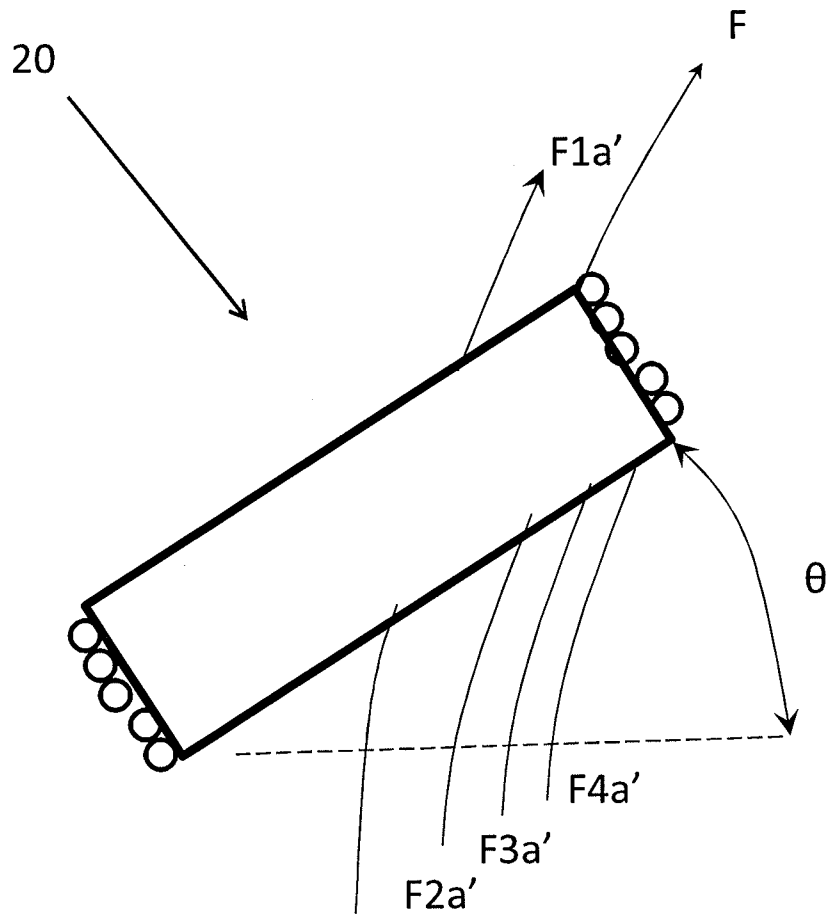

FIG. 8

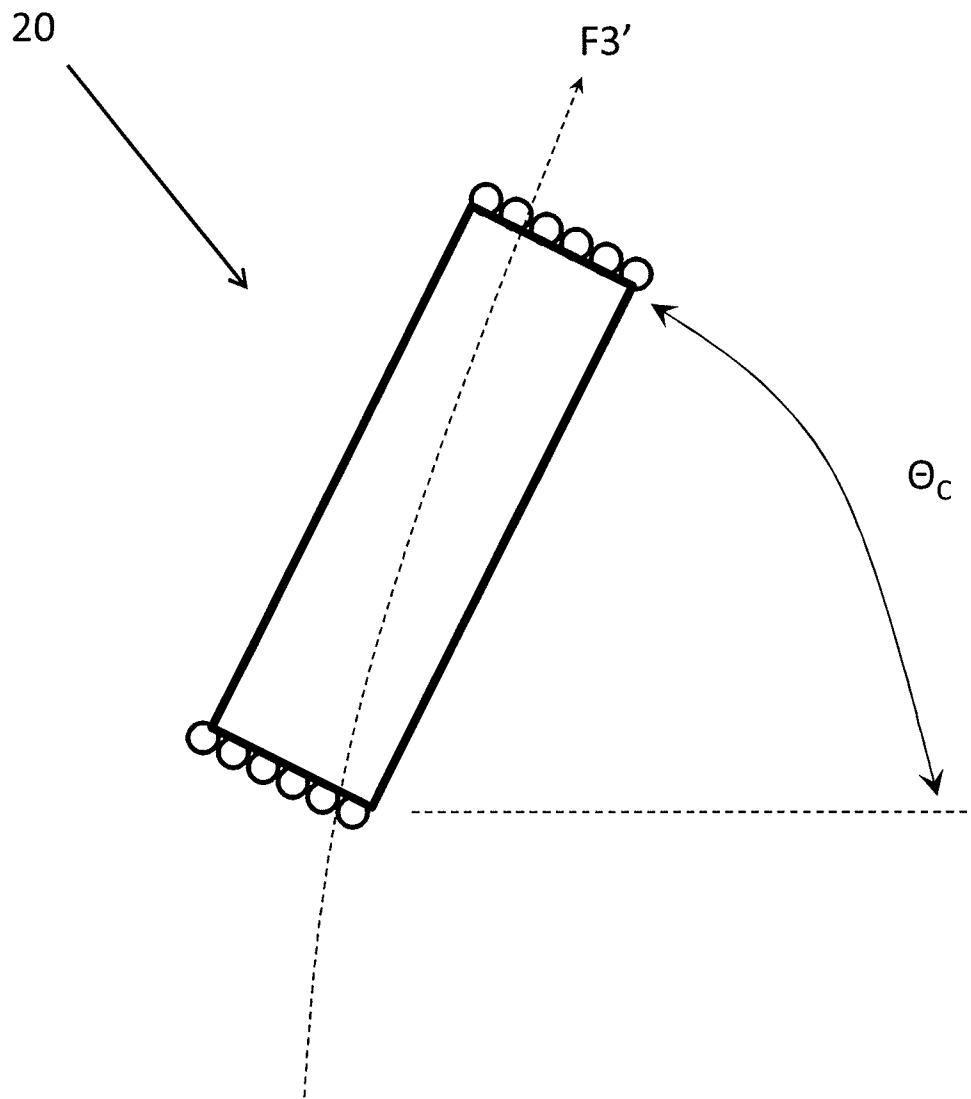

FIG. 9

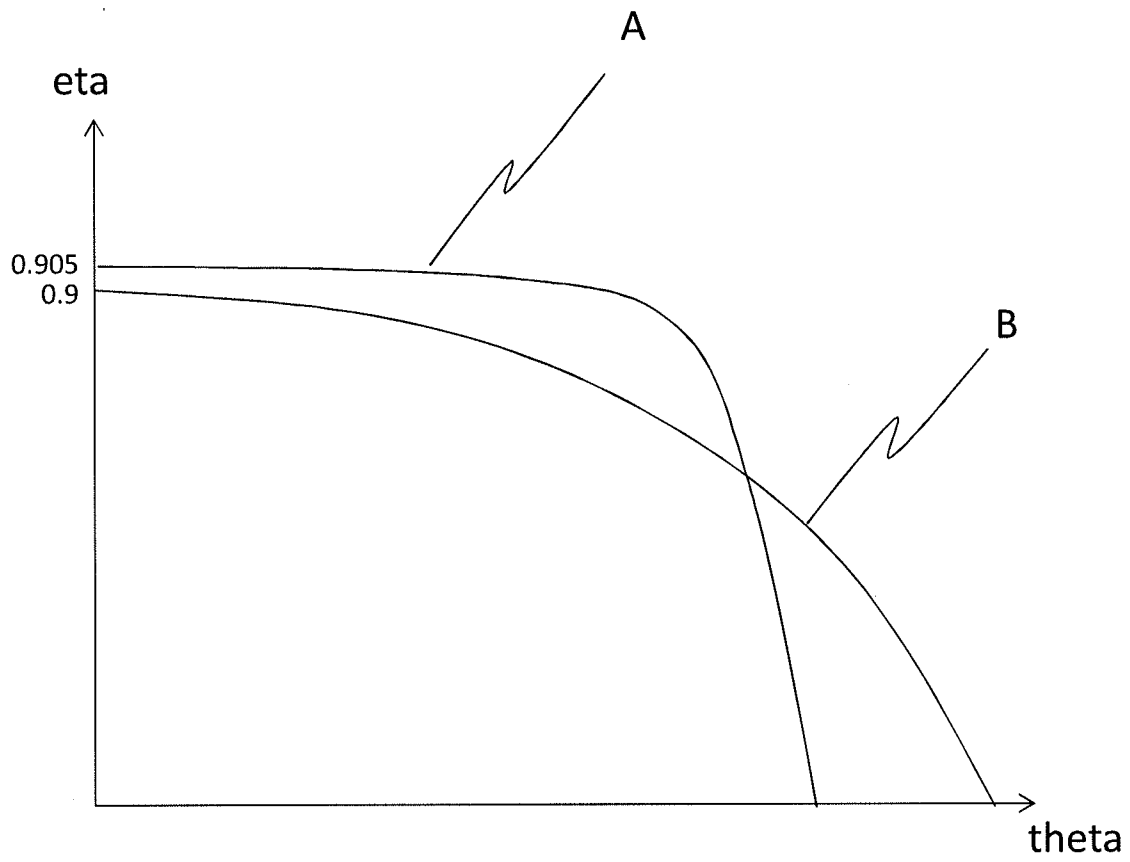

FIG. 10

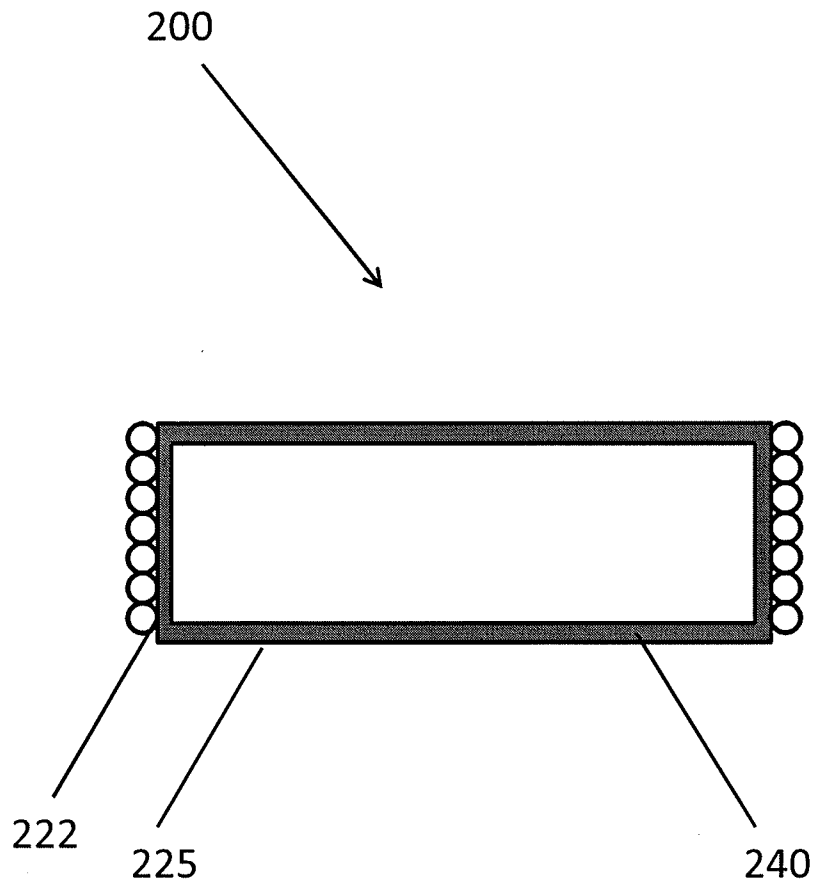

FIG. 11

A. CLASSIFICATION OF SUBJECT MATTER**H02J 17/00(2006.01)i**

According to International Patent Classification (IPC) or to both national classification and IPC

B. FIELDS SEARCHED

Minimum documentation searched (classification system followed by classification symbols)

H02J 17/00; H04B 5/00; A61N 1/08; H02J 7/00

Documentation searched other than minimum documentation to the extent that such documents are included in the fields searched

Korean utility models and applications for utility models

Japanese utility models and applications for utility models

Electronic data base consulted during the international search (name of data base and, where practicable, search terms used)

eKOMPASS(KIPO internal) & Keywords: implant, magnetic flux, housing, wireless power transfer, ferrite

C. DOCUMENTS CONSIDERED TO BE RELEVANT

Category*	Citation of document, with indication, where appropriate, of the relevant passages	Relevant to claim No.
X	US 2004-0138725 A1 (PETER FORSELL) 15 July 2004 See paragraphs [0037]-[0040], claims 2,26-28 and figures 1,4.	9-10
A		1-8
A	US 2012-0169278 A1 (SUNG-JIN CHOI et al.) 05 July 2012 See claims 1,14-17 and figure 2A.	1-10
A	US 2010-0194334 A1 (MILES A. KIRBY et al.) 05 August 2010 See abstract, paragraphs [0048]-[0060] and figures 6A-6C.	1-10
A	KR 10-2012-0007296 A (KOREA ELECTROTECHNOLOGY RESEARCH INSTITUTE) 20 January 2012 See abstract, claims 1-9 and figure 3.	1-10
A	US 2005-0288743 A1 (TAE YOUNG AHN et al.) 29 December 2005 See paragraphs [0033]-[0037], claims 1,10,19,24 and figure 5.	1-10

 Further documents are listed in the continuation of Box C. See patent family annex.

* Special categories of cited documents:

"A" document defining the general state of the art which is not considered to be of particular relevance

"E" earlier application or patent but published on or after the international filing date

"L" document which may throw doubts on priority claim(s) or which is cited to establish the publication date of citation or other special reason (as specified)

"O" document referring to an oral disclosure, use, exhibition or other means

"P" document published prior to the international filing date but later than the priority date claimed

"T" later document published after the international filing date or priority date and not in conflict with the application but cited to understand the principle or theory underlying the invention

"X" document of particular relevance; the claimed invention cannot be considered novel or cannot be considered to involve an inventive step when the document is taken alone

"Y" document of particular relevance; the claimed invention cannot be considered to involve an inventive step when the document is combined with one or more other such documents, such combination being obvious to a person skilled in the art

"&" document member of the same patent family

Date of the actual completion of the international search

20 November 2013 (20.11.2013)

Date of mailing of the international search report

21 November 2013 (21.11.2013)

Name and mailing address of the ISA/KR

 Korean Intellectual Property Office
 189 Cheongsa-ro, Seo-gu, Daejeon Metropolitan City,
 302-701, Republic of Korea

Facsimile No. +82-42-472-7140

Authorized officer

PARK, Hye Lyun

Telephone No. +82-42-481-3463



INTERNATIONAL SEARCH REPORT

Information on patent family members

International application No.
PCT/US2013/052551

Patent document cited in search report	Publication date	Patent family member(s)	Publication date		
US 2004-0138725 A1	15/07/2004	AT 385831 T	15/03/2008		
		AU 2003-263710 A1	08/04/2004		
		AU 2003-263710 B2	14/08/2008		
		CA 2497906 A1	01/04/2004		
		DE 60319106 D1	27/03/2008		
		DE 60319106 T2	05/02/2009		
		EP 1545702 A1	29/06/2005		
		EP 1545702 B1	13/02/2008		
		MX PA05002819 A	03/06/2005		
		US 2006-155347 A1	13/07/2006		
		WO 2004-026399 A1	01/04/2004		
		US 2012-0169278 A1	05/07/2012	CN 102570630 A	11/07/2012
				EP 2472732 A2	04/07/2012
EP 2472732 A3	19/06/2013				
JP 2012-143146 A	26/07/2012				
KR 10-2012-0078995 A	11/07/2012				
WO 2012-093823 A2	12/07/2012				
WO 2012-093823 A3	07/09/2012				
US 2010-0194334 A1	05/08/2010	CN 102301558 A	28/12/2011		
		EP 2356732 A2	17/08/2011		
		JP 2012-517206 A	26/07/2012		
		KR 10-2011-0103395 A	20/09/2011		
		WO 2010-060118 A2	27/05/2010		
		WO 2010-060118 A3	29/07/2010		
		WO 2010-060118 A8	16/06/2011		
KR 10-2012-0007296 A	20/01/2012	None			
US 2005-0288743 A1	29/12/2005	AT 416822 T	15/12/2008		
		DE 60136969 D1	22/01/2009		
		EP 1389079 A1	18/02/2004		
		EP 1389079 A4	09/02/2005		
		EP 1389079 B1	10/12/2008		
		JP 2004-534495 A	11/11/2004		
		KR 10-0606307 B1	28/07/2006		
		KR 10-2002-0089605 A	30/11/2002		
		US 2002-0177884 A1	28/11/2002		
		WO 02-094139 A1	28/11/2002		