

No. 679,672.

Patented July 30, 1901.

W. HERMAN.  
DRILLING MACHINE.  
(Application filed Sept. 14, 1900.)

(No Model.)

3 Sheets—Sheet 1.

Fig. 1

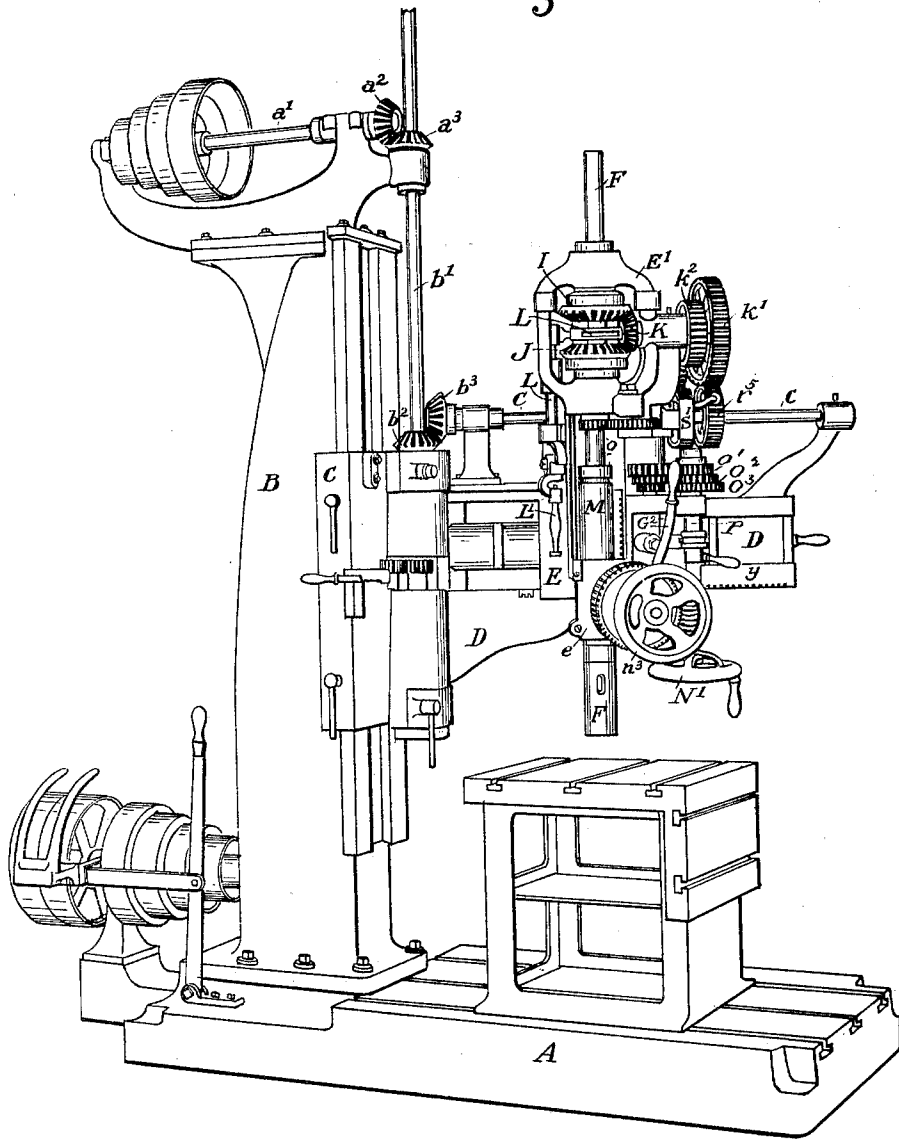

Witnesses.  
Walter A. Knight  
Chas. Herbert Jones

Inventor.  
William Herman  
by L. M. Mosca  
Atty.

W. HERMAN.  
DRILLING MACHINE.

(Application filed Sept. 14, 1900.)

(No Model.)

3 Sheets—Sheet 2.

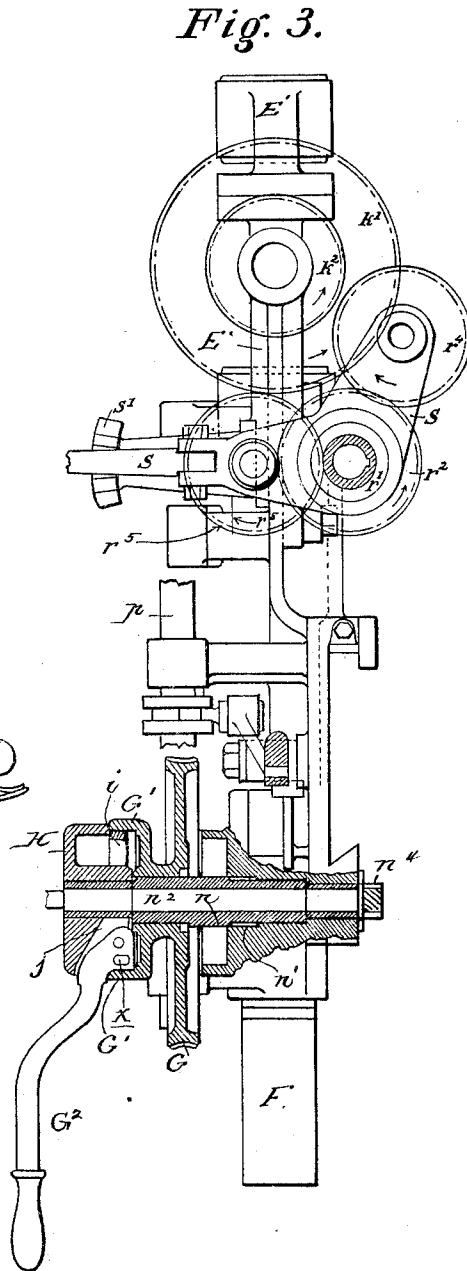
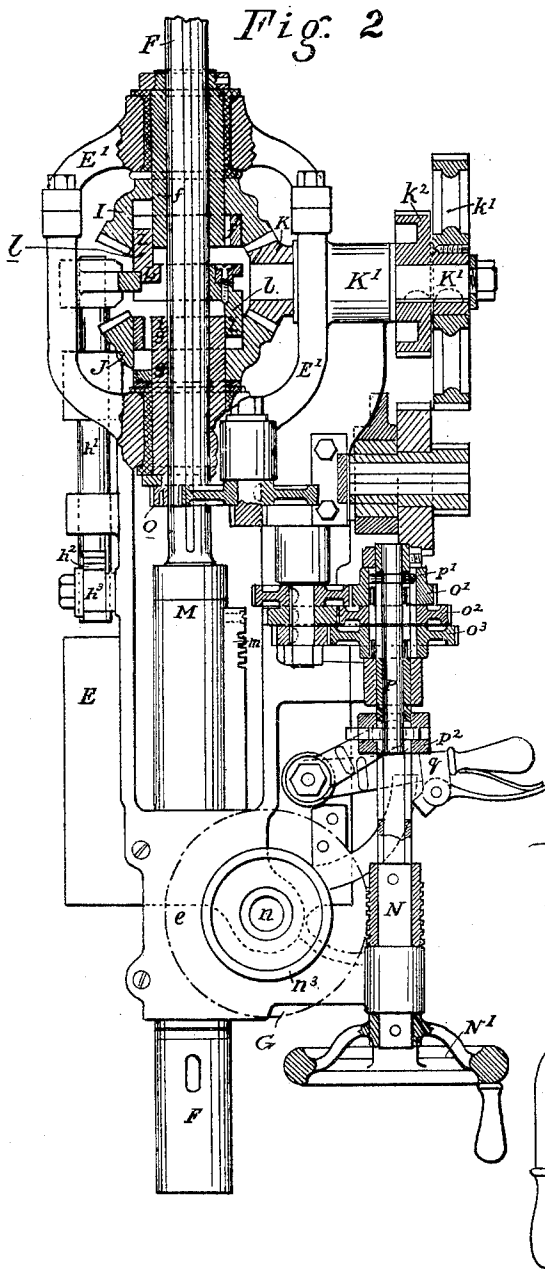

Witnesses.  
 Walter O. Knight.  
 Chas. Herbert Jones

Inventor.  
 William Herman  
 by L. M. Hosen  
 Atty.

W. HERMAN.  
DRILLING MACHINE.  
(Application filed Sept. 14, 1900.)

(No Model.)

3 Sheets—Sheet 3.

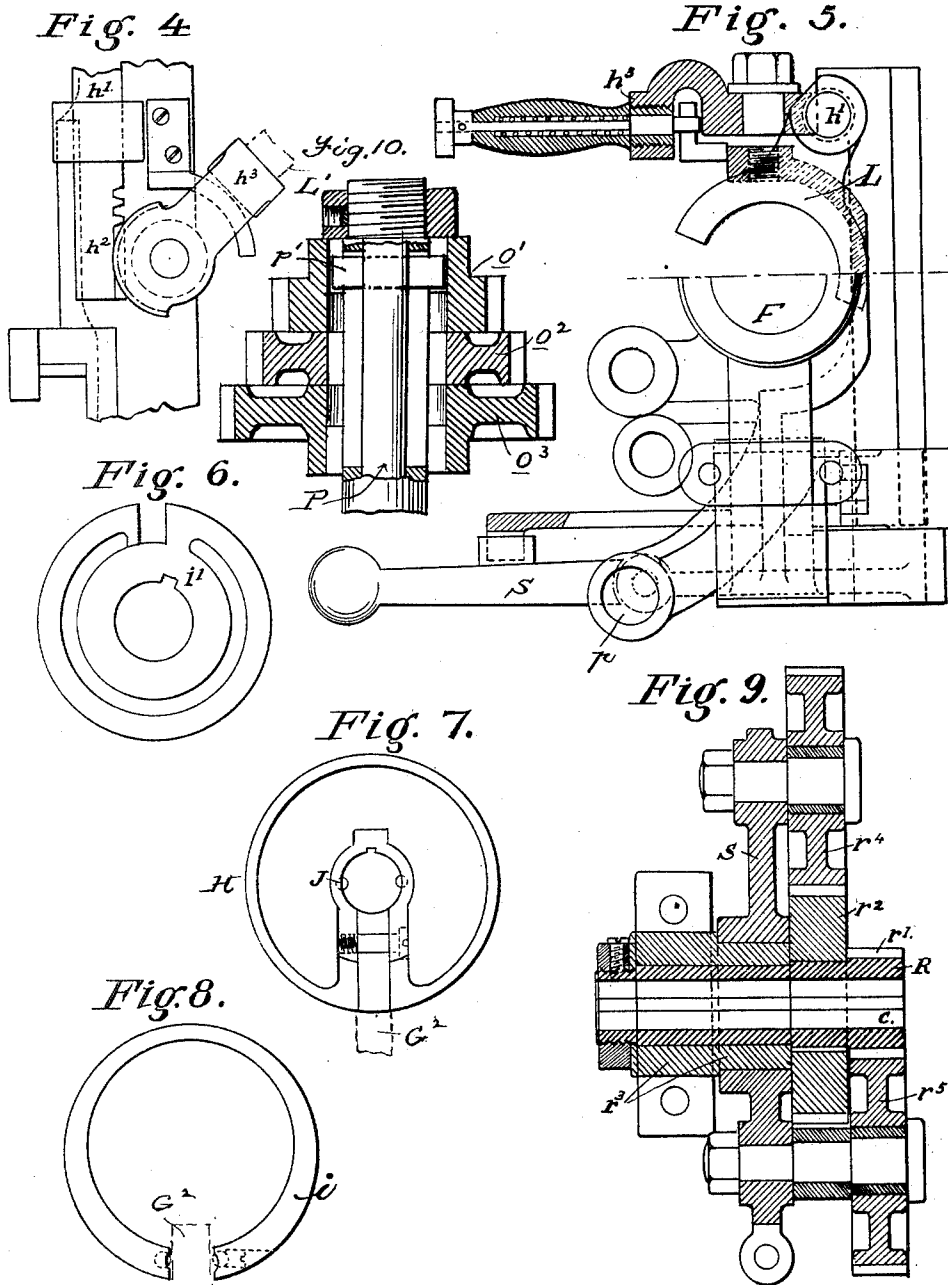

Witnesses.  
*Walter A. Knight*  
*Chas. Herbert Jones*

Inventor.  
*William Herman*  
*By J. M. Hovea*  
 Atty.

# UNITED STATES PATENT OFFICE.

WILLIAM HERMAN, OF CINCINNATI, OHIO, ASSIGNOR TO THE FOSDICK & HOLLOWAY MACHINE TOOL COMPANY, OF SAME PLACE.

## DRILLING-MACHINE.

SPECIFICATION forming part of Letters Patent No. 679,672, dated July 30, 1901.

Application filed September 14, 1900. Serial No. 30,003. (No model.)

*To all whom it may concern:*

Be it known that I, WILLIAM HERMAN, a citizen of the United States, residing at Cincinnati, in the county of Hamilton and State of Ohio, have invented new and useful Improvements in Drilling-Machines, of which the following is a specification.

My invention relates to power drilling-machines of the "radial" type, in which a vertically-adjustable drill-carrier is pivotally mounted upon and in relation to a vertical supporting-column, its object being to improve the same in certain particulars, whereby the general efficiency of the machine is enhanced and its manipulation and control rendered more convenient.

To this end the improvements consist, principally, first, in a simplification and improved structural arrangement of the driving connections for the drill-spindle and its feed mechanism, whereby a positive and regular action is insured; second, in the improved construction and arrangement of the various means of regulation and control whereby all are concentrated at and near the spindle-head in convenient reach of the attendant without leaving his position at the work, and in the improved construction of the feeding devices and mechanism whereby an increased range of speed is attained and the change from one to another effected with convenience and despatch and also whereby the spindle may be instantly disconnected from the power feed devices while in motion and controlled in either direction by hand or instantly reconnected with the power feed devices at any point.

Mechanism embodying my invention is illustrated in the accompanying drawings, in which—

Figure 1 is a general front elevation of a drilling-machine constructed in accordance with my improvements. Fig. 2 is a front elevation, and Fig. 3 a side elevation, of the drill-carrier detached, sectioned in parts to show construction; Fig. 4, a detail elevation of the rack device for shifting the reversing-clutch; Fig. 5, a detail plan of the drill-carrier, showing further the means for shifting the reversing-clutch and the relative positions of the various bearings; Fig. 6, an end

view of one of the sleeves upon the drill-spindle, showing the expansion-ring construction; Fig. 7, an inner face view of the collar in which the hand-lever is pivoted adjacent to the worm-wheel; Fig. 8, a face view of the worm-wheel and its enlarged hub, showing the divided expansion-ring in position; Fig. 9, a cross-section of the rocker-arm, taken through the axis of its pivot, showing the relation of parts; and Fig. 10 is an enlarged sectional detail of the gears  $o'$ ,  $o^2$ , and  $o^3$  and a portion of the shaft P.

Referring to the drawings, A designates a bed-plate constituting a support for the machine, from which rises at one end a vertical column B, finished at one side to parallel guide-surfaces, upon which is mounted in sliding connection a cross-head C, provided with suitable trunnions for the hinged support of a laterally-swinging arm D. This latter is provided at its inner end with trunnions to engage with corresponding trunnions of the cross-head C by means of a vertical pin-  
dle and is also finished at one side in parallel guide-surfaces, upon which is mounted a horizontally-sliding cross-head or saddle E, carrying a vertical drill-spindle F and its driving connections, including a feed mechanism, as hereinafter more particularly described. These parts, except as herein specified, are constructed according to the usual practice in similar mechanism and require no further detailed description.

Initial driving power to the machine is delivered to a short horizontal counter-shaft  $a'$ , held in suitable bearings at the top of the column B, and transmitted thence by bevel-gears  $a^2$   $a^3$  (the latter having a slot-and-feather connection with the shaft) to a vertical shaft  $b'$ , extending downward at the front side of column B, through the corresponding trunnions of the cross-head C and lateral arm D and constituting the axial pivot or pintle of their hinged connection. Thence the power is delivered by bevel-gears  $b^2$   $b^3$  to a horizontal counter-shaft  $c$ , carried in bearings upon the arm D. The cross-head or saddle E is extended upwardly into a yoke E', through which the vertical drill-spindle F has its upper bearing, a lower bearing  $e$  being also provided as a lower extension of the saddle,

these bearings permitting both longitudinal and rotary motion of the spindle.

The means for producing and changing rotary motion of the drill-spindle in either direction are carried directly on the spindle itself. Two oppositely-placed bevel-gears I and J are carried at the inner sides of the yoke upon sleeves  $f$   $g$ , projecting through and having rotating bearings in the yoke-frame, and are driven constantly in opposite directions by an engaging bevel-pinion K, secured upon a shaft  $K'$ , journaled through the side of the yoke  $E'$  and receiving power mediately from the counter-shaft  $c$ , as hereinafter described. The corresponding faces of the bevel-gears I J are countersunk to receive expansion-ring enlargements  $f'$   $g'$  of the sleeves, constructed as shown in Fig. 6. Between the two bevel-gears is a sliding clutch L, splined to the drill-spindle and provided at opposite sides with wedge-fingers  $l$ , adapted to engage in and spread the rings  $f'$   $g'$  to engage the gears, respectively. The clutch is otherwise of ordinary construction and is moved by a dog attached to a vertically-sliding rod  $h'$ , moved by a rack-and-pinion device  $h^2$  by means of a hand-lever  $h^3$  on the pinion. The general effect of the friction-gear thus placed is to start the spindle in either direction without shock or jar, yet with instant rapidity of action, due to the location of the device directly on the drill-spindle, whereby all lost motion of intervening parts is avoided. It also results that the governing-lever  $h^3$  is located directly alongside of the spindle itself in convenient reach of the operator, who may therefore control all the movements without removing his eye from the drill at work. The advantages of location here specified do not depend upon the precise form of the friction-gear, as others might be used with similar benefit.

The feed mechanism is constructed and arranged as follows: The first essential element is a sleeve M, seated upon the spindle with a rotating fit, but engaging the same in perpendicular motion. The sleeve M is provided with an external longitudinal rib, whose outer surface is cut into teeth, constituting a rack  $m$ . The spindle F rotates within the sleeve M; but the latter is prevented from rotation by the engagement of its rack-rib  $m$  in a corresponding groove in the bearing  $e$ , through which it passes. Adjacent to the rack  $m$  is a horizontal hollow counter-shaft  $n$ , provided with a spur-pinion  $n'$ , engaging said rack.

The power devices for elevating and depressing the spindle F are as follows: A worm-wheel G runs loosely upon the hollow shaft  $n$ , but is engaged in rotation therewith, as desired, by the following construction: The worm-wheel has an enlarged hub  $G'$  at one side countersunk to form an annular chamber for the reception and play of a divided ring  $i$ , which by expansion caused by insertion of a wedge between its divided terminals

engages frictionally the inner circumferential wall of the enlarged hub. The ring is loosely held in place by a collar H, rigidly secured to the hollow shaft  $n$ , adjacent to the hub  $G'$ . The collar has a radially-slotted hub  $j$  projecting somewhat within the chamber of the hub  $G'$ , in which slot is pivoted the hand-lever  $G^2$ , free to move therein and extending radially outward. The parts described are placed together, as indicated in Fig. 3, and the lever  $G^2$  is provided with wedge-shaped projections  $x$  at opposite sides of its head, so that when the handle of the lever is moved toward the worm-gear its wedge-shaped projections engage between the terminals of the ring  $i$  and expand the same, thereby frictionally engaging the worm-wheel G with the shaft  $n$ . The lever  $G^2$  when it has disengaged the split ring  $i$  also serves as a means of rotating the hollow shaft  $n$  by hand, whereby the spindle F may be quickly elevated or depressed and at any point instantly reconnected with the worm-wheel G. Extending through the hollow shaft or sleeve  $n$  is a central shaft  $n^2$ , provided at its forward end with a hand-wheel  $n^3$  and at the opposite or inner end with a spur-pinion  $n^4$ , engaging a horizontal rack  $\gamma$  on the swinging arm D, by which means the entire drill-carrier E may be moved radially outward or inward in relation to the column D.

The worm-wheel is driven by a vertical screw-shaft N, arranged adjacent thereto and deriving power through a gear-train as follows: The spindle F carries a spur-gear  $o$ , meshing through intermediate idler-gears carried on studs secured to the frame with three spur-gears  $o'$   $o^2$   $o^3$  of different diameters in series, carried upon the worm-shaft N, extended. The gears  $o'$   $o^2$   $o^3$  run loosely on the shaft N, except as alternately connected therewith by the following mechanism: The shaft N is hollow through the upper part of its length and carries an internal rod or shaft  $p$ , having near its upper end a cross-key  $p'$  set therein, projecting diametrically at one or both sides through a corresponding vertical slot or slots in the hollow shaft N and beyond into engagement with one or the other of the gears  $o'$   $o^2$   $o^3$ , according to the degree of elevation of the shaft  $p$ . The central gear  $o^2$  is a trifle wider than the said key and provided with one or more radial key-slots, and the upper gear  $o'$  and lower one  $o^3$  each with a circular counterbore adjacent to the central gear (allowing the cross-key  $p'$  to play without engagement) and adjacent to the counterbored zone with one or more key-slots. The action, therefore, is as follows: The shaft  $p$  being at its lowest limit of adjustment, its key  $p'$  engages the lowest gear  $o^3$  and rotates the hollow shaft N. The rod being elevated one degree, the key  $p'$  passes into the counterbore of gear  $o^3$ , and the key is therefore disengaged from the gear. By elevation a second degree the key is brought into engagement with the central gear  $o^2$ , by a third degree into the

counterbore of the gear  $o'$ , where it is again entirely disengaged, and by a fourth degree of elevation it is brought into engagement with the upper gear  $o'$ . Thus it will be seen that a neutral zone of disengagement exists adjacent to the central gear at each side, and by moving the key to the same the feed may be stopped at will; also, that this period of cessation intervenes between each change of speed in the feed, leaving the shaft N free to be moved by hand, if desired, so that the drill-spindle, whether in motion or not, may be elevated or depressed by hand to any point, or the power-feed may be thus instantly stopped while the drill is in operation.

The movements of the central shaft  $p$  are controlled by a sleeve  $p^2$ , arranged to slide vertically upon the hollow shaft N and connected with the inner shaft  $p$  by a connection extending through a vertical slot in the hollow shaft. The sleeve has a circumferential groove whereby it is engaged in the usual manner with a yoke-piece or short arm of a hand-lever  $q$ , pivoted upon the saddle-frame and provided with means to secure it in desired positions. This lever also, it will be observed, is located convenient to the work, and by its use the described movements of the power-feed may be instantly controlled or the power disconnected, leaving the feed to be controlled by the hand-wheel N', secured to the lower end of the shaft N. The use of three gears instead of two (as is usual) also gives a wider range of speed to the feed.

The rotative speed of the drill is varied by the following mechanism: Upon the rear counter-shaft  $c$  (carried upon the swinging arm D) is placed a sleeve or extended hub R, with two gears  $r^1 r^2$  rigidly secured thereto. The sleeve is splined to the shaft  $c$  and is embraced by a yoke or fixed collar  $r^3$  of the drill-carrier frame E, whereby it is moved as the latter moves along the shaft  $c$ , carrying the gears  $r^1 r^2$  in constant relations with the drill-carrier E. Adjacent to the gears  $r^1 r^2$  is a rocker-arm S, pivoted upon an extension of the collar  $r^3$  and carrying upon each of its prongs a spur-gear  $r^4 r^5$ , respectively, in constant mesh with the gears  $r^1 r^2$ , respectively, and in such relation to gears  $k^1 k^2$  upon the counter-shaft K' of the drill-carrier that by slight oscillation of the rocker-arm in either direction one of the gears  $r^1 r^2$  is engaged with corresponding gear  $k^1$  or  $k^2$  and the other disengaged. This change is readily effected while the parts are in motion, so that the change of speed is instantaneously effected. The forward prong of the rocker-arm S is extended into a hand-lever  $s$  and operates in the usual manner over a rack-bar  $s'$ , with recesses to secure it in ultimate positions.

Thus it will be seen that all the various controlling and adjusting mechanisms are so arranged that all are within reach of the attendant from his position at the work and can be manipulated without change of his position.

I claim as my invention and desire to secure by Letters Patent of the United States—

1. In a drilling-machine, the arrangement, in combination with the supporting-column and the laterally-swinging arm; the cross-head or drill-carrier extended upwardly to form a yoke; a drill-spindle mounted in said yoke; a lateral driving-shaft carried by the yoke and provided with a bevel-pinion; opposing bevel-gears within the yoke and loose on the spindle, and meshing with said pinion, said gears carrying expansible friction devices; a vertically-movable clutch-operating device splined to the drill-spindle and engaging the clutch device of the bevel-gears alternately; and mechanism for moving and retaining the clutch-operating device in its alternate positions or in an intermediate position of disengagement substantially as set forth.

2. In a drilling-machine, the combination with a supporting-column, and a laterally-swinging arm supported therefrom; of a cross-head or drill-carrier movable on said arm and extended upwardly to form a yoke; a vertical drill-spindle; a lateral driving-shaft carried by the yoke and having a bevel-pinion; two opposite bevel-gears loose on the drill-spindle, and within said yoke; a vertically-movable clutch device within the yoke between the loose gears and splined to the drill-spindle, and engaging said gears alternately; and mechanism for moving and retaining the clutch device in its alternate positions or in an intermediate position of disengagement, substantially as set forth.

3. In a drilling-machine the combination with a supporting-column and a laterally-swinging arm supported therefrom; of a cross-head or drill-carrier supported in horizontal guides on said arm, and extended upwardly to form a yoke; a vertical spindle; mechanism supported essentially within the yoke for controlling, varying and reversing the spindle motion; mechanism for moving the spindle vertically while in motion and varying the speed of said motion; and mechanism for moving the entire cross-head or drill-carrier on the lateral arm—all of said mechanism being located on said cross-head or drill-carrier—and the means of controlling said mechanism being arranged at the same side contiguous to the work in convenient reach of the attendant without change of position, substantially as set forth.

4. In a drilling-machine, the combination with a supporting-column, a laterally-swinging arm, a cross-head or drill-carrier movable on said arm, a vertical spindle; a power-shaft; a vertical transmitting-shaft; and gearing between said shafts; of a horizontal transmitting-shaft on the swinging arm adjacent to the drill-carrier, said last-named shaft and vertical transmitting-shaft being interconnected by miter-gears and said horizontal shaft having a sleeve splined thereto and provided with a gear-wheel adjustable on the shaft with said sleeve; a lateral driving-shaft

and gearing between it and the drill-spindle; and means connecting the gear on said sleeve with the gear on the said driving-shaft whereby the former constitutes a direct and positive means of delivering power to the spindle at every point of its adjustment, substantially as set forth.

5. In a drilling-machine of the character indicated, the combination of the laterally-swinging arm; the drill-carrier movably mounted thereon; a power-transmitting shaft adjacent to and parallel with the path of the drill-carrier; one or more gears upon a common extended sleeve or hub splined upon the transmitting-shaft a yoke or collar upon the frame of the drill-carrier engaging in a groove of the sleeve or hub, permitting rotation of the latter but carrying it with the movements of the drill-carrier; and a rocker-arm pivoted upon said sleeve or hub, carrying gears in constant mesh with the gears of the sleeve or hub and adapted by oscillation of the rocker-arm to be brought alternately into mesh with gears upon the drill-carrier engaged with the drill-spindle, substantially as set forth.

6. In a drilling-machine of the character indicated, the combination, with the lateral arm and the drill-carrier movable thereon, and a hollow shaft arranged horizontally upon the drill-carrier adjacent to the drill-spindle and carrying the feed devices operating on the spindle, of a central shaft carried within and through said hollow shaft and provided at its outer end with a hand-wheel and at its inner end with a spur-pinion engaging rack-teeth upon the lateral supporting-arm, substantially as set forth.

7. In a drilling-machine of the character indicated, the combination with the drill-spindle, its rack-sleeve, and adjacent shaft with rack-pinion engaging said sleeve, of a worm-wheel (for receiving the feed-power) normally loose upon said shaft and provided with a counterbored hub; a divided spring-ring contained loosely in the counterbore of said hub; a collar rigidly secured to the shaft adjacent to the worm-wheel and having a radially-slot-

ted hub projecting within the chamber of the hub of the worm-wheel; and a hand-lever pivoted radially to said collar in constant engagement between the opposite terminals of said ring, and by its movement in one direction expanding said ring into frictional engagement with the inner wall of the worm-wheel hub, thereby engaging the worm-wheel frictionally with the hub, and by movement in the other direction releasing said worm-wheel while retaining its own operative relation to the shaft as an independent mover, substantially as set forth.

8. In a drilling-machine of the character indicated, a worm-shaft of the drill feeding mechanism constructed hollow for a part or all of its length, and provided with a slot; three gears normally loose upon said shaft, and a rod carried in the hollow of the worm-shaft and longitudinally adjustable, and provided with a cross-key working in the slots of said shaft; said gears being arranged vertically one above the other on the same shaft and the central gear having radial recesses only and each of the outer gears having a circular counterbore adjacent to said center gear and having one or more key-slots adjacent to its own counterbore zones, substantially as set forth.

9. In combination with the hollow and slotted worm-shaft, the three gears normally loose thereon and arranged one above the other, and the rod and cross-key for engaging the gears alternately to the shaft, a sleeve mounted on the shaft and secured to the rod within by a radial pin through the slot and a yoke-lever pivoted to the frame of the machine and engaging the sleeve to move the same up and down as desired, substantially as set forth.

In testimony whereof I have hereunto set my hand in presence of two subscribing witnesses.

WILLIAM HERMAN.

Witnesses:

L. M. HOSEA,

WALTER A. KNIGHT.