

(19) World Intellectual Property Organization  
International Bureau



(43) International Publication Date  
6 September 2002 (06.09.2002)

PCT

(10) International Publication Number  
**WO 02/069414 A2**

- (51) International Patent Classification<sup>7</sup>: **H01M** Farmington, MI 48336 (US). **SMAGA, John**; 24760 N. Cromwell, Franklin, MI 48025 (US).
- (21) International Application Number: PCT/US02/05843
- (22) International Filing Date: 27 February 2002 (27.02.2002)
- (25) Filing Language: English
- (26) Publication Language: English
- (30) Priority Data: 60/272,274 28 February 2001 (28.02.2001) US
- (71) Applicant: **OVONIC BATTERY COMPANY, INC.** [US/US]; 1707 Northwood Dr., Troy, MI 48084 (US).
- (72) Inventors: **CORRIGAN, Dennis, A.**; 3793 Burkoff, Troy, MI 48084 (US). **HIGLEY, Lin**; 4791 Foxcroft, Troy, MI 48098 (US). **HOLLAND, Arthur**; 1710 Sadie Shore Drive, Commerce Township, Oakland County, MI 48382 (US). **MULLER, Marshall**; 23644 Power Road,
- (74) Agents: **SCHLAZER, Philip, H.** et al.; Energy Conversion Devices, Inc., 2956 Waterview Drive, Rochester Hills, MI 48309 (US).
- (81) Designated States (*national*): AU, BR, CA, CN, IN, JP, KR, MX, NO, RU, SG, UA.
- (84) Designated States (*regional*): European patent (AT, BE, CH, CY, DE, DK, ES, FI, FR, GB, GR, IE, IT, LU, MC, NL, PT, SE, TR).
- Published:**  
— *without international search report and to be republished upon receipt of that report*
- For two-letter codes and other abbreviations, refer to the "Guidance Notes on Codes and Abbreviations" appearing at the beginning of each regular issue of the PCT Gazette.*



**WO 02/069414 A2**

(54) Title: ELECTROCHEMICAL CELL WITH ZIGZAG ELECTRODES

(57) Abstract: An electrochemical cell having an electrode stack arranged in a zigzag configuration. Additional electrodes may be inserted within the folds of the zigzag configuration. Preferably, the electrochemical cell is a prismatic cell.

**ELECTROCHEMICAL CELL WITH ZIGZAG ELECTRODES****Related Application Information**

This application claims the benefit of U.S.  
5 Provisional Application No. 60/272274 filed February  
28, 2001.

**Field of the Invention**

Generally, this invention relates to rechargeable  
10 batteries. More specifically, this invention relates  
to prismatic rechargeable batteries.

**Background of the Invention**

In rechargeable electrochemical cells, weight and  
15 portability are important considerations. It is also  
advantageous for rechargeable cells to have long  
operating lives without the necessity of periodic  
maintenance. Rechargeable electrochemical cells are  
used in numerous consumer devices such as calculators,  
20 portable radios, and cellular phones. They are often  
configured into a sealed power pack that is designed as  
an integral part of a specific device. Rechargeable  
electrochemical cells can also be configured as larger  
"cell packs" or "battery packs".

25 Rechargeable electrochemical cells may be  
classified as "nonaqueous" cells or "aqueous" cells.  
Examples of a nonaqueous electrochemical cell are

lithium and lithium-ion cells which typically use a liquid organic or polymer electrolyte. Aqueous electrochemical cells may be classified as either "acidic" or "alkaline". An example of an acidic  
5 electrochemical cell is a lead-acid cell which uses lead dioxide as the active material of the positive electrode and metallic lead, in a high-surface area porous structure, as the negative active material. Examples of alkaline electrochemical cells are nickel cadmium cells  
10 (Ni-Cd) and nickel-metal hydride cells (Ni-MH). Ni-MH cells use negative electrodes having a hydrogen absorbing alloy as the active material. The hydrogen absorbing alloy is capable of the reversible electrochemical storage of hydrogen. Ni-MH cells  
15 typically use a positive electrode having nickel hydroxide as the active material. The negative and positive electrodes are spaced apart in an alkaline electrolyte. Preferably, an alkaline electrolyte is an aqueous solution of an alkali metal hydroxide such as  
20 such as potassium hydroxide, sodium hydroxide and lithium hydroxide.

Upon application of an electrical potential across a Ni-MH cell, the hydrogen absorbing alloy active material of the negative electrode is charged by the  
25 electrochemical absorption of hydrogen and the electrochemical discharge of a hydroxyl ion, forming a metal hydride. This is shown in equation (1):

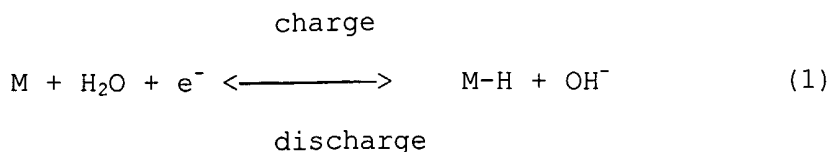

5

The negative electrode reactions are reversible. Upon discharge, the stored hydrogen is released from the metal hydride to form a water molecule and release an electron.

10

Hydrogen absorbing alloys called "Ovonic" alloys result from tailoring the local chemical order and local structural order by the incorporation of selected modifier elements into a host matrix. Disordered hydrogen absorbing alloys have a substantially increased density of catalytically active sites and storage sites compared to single or multi-phase crystalline materials. These additional sites are responsible for improved efficiency of electrochemical charging/discharging and an increase in electrical energy storage capacity. The nature and number of storage sites can even be designed independently of the catalytically active sites. More specifically, these alloys are tailored to allow bulk storage of the dissociated hydrogen atoms at bonding strengths within the range of reversibility suitable for use in secondary battery applications.

25

Some extremely efficient electrochemical hydrogen storage alloys were formulated, based on the disordered materials described above. These are the Ti-V-Zr-Ni type active materials such as disclosed in U.S. Patent

No. 4,551,400 ("the '400 Patent") the disclosure of which is incorporated herein by reference. These materials reversibly form hydrides in order to store hydrogen. All the materials used in the '400 Patent  
5 utilize a generic Ti-V-Ni composition, where at least Ti, V, and Ni are present and may be modified with Cr, Zr, and Al. The materials of the '400 Patent are multiphase materials, which may contain, but are not limited to, one or more phases with C<sub>14</sub> and C<sub>15</sub> type  
10 crystal structures.

Other Ti-V-Zr-Ni alloys, also used for rechargeable hydrogen storage negative electrodes, are described in U.S. Patent No. 4,728,586 ("the '586 Patent"), the contents of which is incorporated herein by reference.  
15 The '586 Patent describes a specific sub-class of Ti-V-Ni-Zr alloys comprising Ti, V, Zr, Ni, and a fifth component, Cr. The '586 Patent, mentions the possibility of additives and modifiers beyond the Ti, V, Zr, Ni, and Cr components of the alloys, and generally  
20 discusses specific additives and modifiers, the amounts and interactions of these modifiers, and the particular benefits that could be expected from them. Other hydrogen absorbing alloy materials are discussed in U.S. Patent Nos. 5,096,667, 5,135,589, 5,277,999, 5,238,756,  
25 5,407,761, and 5,536,591, the contents of which are incorporated herein by reference.

In order to achieve high power Ni-MH batteries (for example, for use in hybrid electric vehicle

applications), it is advantageous to increase the surface area of the electrodes as much as possible. With cylindrical cells, very high surface area can be achieved without a high parts count. Typically, one  
5 positive electrode and one negative electrode are wound together with interleaved separator layers that prevent contact of the positive and negative electrodes. The surface area can be increased by using longer and thinner electrodes without increasing the number of  
10 electrodes, which remains at two.

However, there are certain disadvantages to using cylindrically wound cells. Special techniques are needed to provide low resistance connection between terminals and the electrodes. Also, the packaging  
15 efficiency of cylindrical cells is inferior to that of prismatic cells. As well, there are also some upper limitations on the size of the cylindrical cells that can be manufactured as well as the length of electrodes that can be conveniently wound into a coil (due, at  
20 least in part, to a variation in the radius of the winding). Heat transfer can also be an issue with large cylindrical cells.

There have been attempts to build wound prismatic electrochemical cells of various types. Instead by  
25 winding around a central spindle rod, the electrodes are wound around a flat plate or fixture (and, hence,

are a "flat rolled" configuration). The cross-section of the wound electrodes is be more of a flattened oval rather than round and would fit into a prismatic case.

In a conventional prismatic design of fixed  
5 dimensions, the electrode surface area can be increased by increasing the electrode count by using thinner electrodes. A difficulty with this approach is that the cost increases with the increased parts count that is due to the increased electrode count. Hence, there  
10 is a need for a prismatic electrochemical cell that can have a large electrode surface area with a small parts count.

#### Summary of the Invention

15 One aspect of the present invention is an electrochemical cell, comprising: at least one positive electrode; at least one negative electrode; and an electrolyte, wherein the at least one positive electrode and/or the at least one negative electrode  
20 folded in a zigzag configuration.

Another aspect of the present invention in an electrochemical cell, comprising: an electrode stack including a positive electrode and a negative electrode, the electrode stack folded in a zigzag  
25 configuration having folds and creases; and an electrolyte.

Another aspect of the present invention is an electrochemical cell, comprising: an electrode folded in a zigzag configuration having folds and creases; at least one counter-electrode disposed within one or more  
5 of the folds of the electrode; and an electrolyte.

Another aspect of the present invention is an electrochemical cell, comprising: an electrode folded in a zigzag configuration having folds and creases; and at least one bifold counter-electrode having a first  
10 leg and a second leg, the first leg and the second leg disposed within a first and a second fold on the same side of the zigzag configuration of the electrode.

Another aspect of the present invention is an electrochemical cell, comprising: a bifold negative  
15 electrode having a first and a second leg; a bifold positive electrode having a first and a second leg; and an electrolyte, wherein the first leg of the negative electrode is disposed between the first and second leg of the positive electrode, and the first leg of the  
20 positive electrode is disposed between the first and second leg of the negative electrode.

Another aspect of the present invention is an electrochemical cell, comprising: an electrode stack including an electrode disposed between a first and a  
25 second counter-electrode, the electrode stack folded in



a zigzag configuration with folds and creases; and an electrolyte.

Preferably, the electrochemical cells disclosed above are prismatic electrochemical cells.

5

#### **Brief Description of the Drawings**

10           Figure 1A shows a an embodiment of the present invention of a zigzag bielectrode stack folded in a zigzag configuration;

          Figure 1B shows a cross-sectional view of the zigzag bielectrode stack from Figure 1A;

15           Figure 2 shows an embodiment of the present invention of a positive electrode folded in a zigzag configuration with negative electrode disposed within the folds;

          Figure 3A shows an embodiment of the present invention of a centrally connected electrode pair referred to as a bifold electrode pair;

          Figure 3B shows an embodiment of the present invention of a positive bifold electrode pair interweaved with a negative bifold electrode pair;

25           Figure 3C shows a stack of interweaved positive and and negative bifold electrodes;

Figure 4A is an embodiment of the present invention of a positive electrode folded in a zigzag configuration with interleaved electrode pairs;

Figure 4B is a cross-sectional view of Figure 4A;

5 Figure 5 is a trielectrode stack folded in a zigzag configuration;

Figure 6A is a trielectrode zigzag stack with hydrophobic material disposed within the folds;

10 Figure 6B is trielectrode zigzag stack sandwiched between two hydrophobic layers;

Figure 7 is a bielectrode zigzag stack that includes positive and negative current collection tabs;

15 Figure 8 is a trielectrode zigzag electrode stack that includes a central positive electrode disposed between two negative electrodes and which also includes negative current collection tabs;

Figure 9A shows an electrode belt with current collection wires placed at fold points along the belt; and

20 Figure 9B shows a bielectrode zigzag stack with positive and negative current collection wires.

#### Detailed Description of the Invention

25 Figure 1A shows a first embodiment of the present invention. The embodiment shown is referred to as the

"bielelectrode zigzag stack". The bielectrode zigzag stack 2 comprises a positive electrode 4, a negative electrode 6, and a separator 8 disposed in between the positive electrode 4 and the negative electrode 6. It is noted that the negative electrode serves as a "counter electrode" for the positive and the positive electrode serves as a "counter-electrode" for the negative. (That is, the positive and negative electrodes are "counter electrodes" of each other).

10 The electrode stack 2 is repeatedly folded over back and forth (in a accordion-like fashion) to form a repeatable zigzag configuration. The closed ends of the zigzag configuration are referred to as the fold lines or creases 12. The V-shaped regions 10 between adjacent segments of the zigzag configuration are referred to as the folds 10 of the configuration. Figure 1B shows a cross-sectional view of the zigzag electrode stack 2 from Figure 1A. The zigzag electrode stack 2 has segments 2A through 2G and fold lines 12. 15 The V-shaped regions between adjacent segments (such as between segments 2A and 2B) are folds 10A through 10F. Folds 10A, 10C and 10E are folds on one side of the zigzag configuration while folds 10B, 10D and 10F are all folds on the opposite side of the zigzag 20 configuration. It is noted that the segments 2A 25

through 2G of the zigzag electrode stack will be pushed close together in a prismatic battery case.

The bielectrode zigzag electrode stack will have an electrode count of two, but can be packaged in a conventional prismatic cell case with high packaging efficiency. This allows for very high surface area with a low parts count, but avoids the packaging efficiency issues of cylindrical cells as well as some of the mechanical assembly problems of wound cells. In the bielectrode zigzag electrode stack shown in Figures 1A and 1B, with two electrodes, only one side of each electrode is adjacent to a counter electrode and, hence, only one side of each electrode is utilized. Thus only one-half of the electrode surface area is utilized. It is noted that the electrode material may optionally be removed at the fold lines or creases to facilitate folding.

A second embodiment of the present invention (also referred to as "Variation 1") is shown in Figure 2. This is a zigzag electrode with interleaved single electrodes. In the embodiment shown, the positive electrode 4 is repeatedly folded in a zigzag configuration with a separator 8 on each side. A single negative electrode is disposed into one or more, and preferably each, of the folds 10 of the zigzag arrangement. This design utilizes both sides of all of

the electrodes and the total electrode surface area is utilized. However, the parts count reduction is limited to about a 50% reduction over the conventional prismatic battery cell design. It is noted that roles  
5 of the positive and negative electrodes may be reversed. That is, a single negative electrode may be folded in a zigzag configuration while a single positive electrode is disposed in each of the folds.

A third embodiment of the invention (also referred  
10 to as "Variation 2") is shown in Figures 3A-C. A folded centrally connected electrode pair 18, referred to herein as a "bifold electrode pair", is shown in Figure 3A. The bifold electrode 18 has a closed end 22 referred to as the fold line or crease of the bifold  
15 electrode. The bifold electrode also has a fold 20 between the two segments 18A and 18B. Active electrode material may be removed from the fold line 22 to facilitate folding of the bifold electrode. Each bifold electrode 18 includes a pair of electrode  
20 segments or legs 18A and 18B. The fold line 22 of the folded pair serves as a common edge of the first electrode leg 18A and the second electrode leg 18B. As noted, the V-shaped region between the legs 18A and 18B is the fold 20.

25 Referring to Figure 3B, a positive bifold electrode 24 and a negative bifold electrode 26 are

interleaved. That is, an electrode leg 18B of a positive bifold electrode 24 is disposed within the fold of a negative bifold electrode while an electrode leg 18A of the negative bifold electrode 26 is disposed  
5 within the fold of the positive bifold electrode 24. Separators (not shown) electrically isolate the positive electrode legs from the negative electrode legs. The arrangement shown in Figure 3B is a single set of interleaved positive and negative bifold  
10 electrodes. Multiple sets of interleaved positive and negative bifold electrodes may then be stacked as shown in Figure 3C to form an electrode stack that can be placed within a prismatic battery case. Separators (not shown) are placed between the positive and  
15 negative electrode legs within the stack. This design utilizes both sides of all of the electrodes and the total electrode surface area is utilized. In this case the electrode count is reduced a total of 50% over the conventional prismatic electrochemical cell design.

20 A fourth embodiment of the present invention (also referred to as "Variation 3") is shown in Figures 4A and 4B. This is an example of a zigzag electrode with interleaved bifold electrode pairs. The positive electrode 4 is folded in a zigzag configuration with a  
25 separator 8 on each side. Centrally connected bifold negative electrode pairs 26 are inserted on both sides

of the zigzag electrode so as to fill each of the folds with a single leg of a negative electrode bifold pair. As shown, the legs of each bifold negative electrode 26 are inserted within adjacent folds on the same side of the zigzag structure formed by the positive electrode 4. As noted, it is preferable that a bifold negative electrode pair 26 is inserted over every other fold line of the zigzag positive electrode configuration on each side of the zigzag electrode. In this manner, only a single negative electrode leg (of a bifold pair) is disposed within each of the folds of the zigzag positive electrode 4. This design utilizes both sides of all electrodes and the total electrode surface area is utilized. In this case, the negative electrode count is reduced another 50% so that the total parts count reduction is about 75% over the conventional prismatic battery cell design. Figure 4A is the three-dimensional view of the electrode structure while Figure 4B is a cross-sectional view. It is noted, that the roles of the positive and negative electrodes may be reversed. That is, the negative electrode may be folded in a zigzag configuration while the legs of positive electrode bifolds are positioned within the folds.

A fifth embodiment of the invention (Also referred to as "Variation 4") is shown in Figure 5. Figure 5

shows a trielectrode zigzag electrode stack. In this embodiment of the invention, a central positive electrode 4 is disposed between two negative electrodes 6. Separators (not shown) are disposed between the central positive electrode and the two negative electrodes. The entire electrode stack (i.e., central positive electrodes, outer negative electrodes and separators) is repeatedly folded in a zigzag configuration. In this case, the total electrode parts count is reduced to three. The outer negative electrodes have about half the capacity loading as in the other embodiments described above. The negative electrodes are folded over themselves so that only 50% of the negative electrodes are utilized. However, both sides and 100% of the positive electrode surface area is utilized so that the total electrode surface area utilized for charge-discharge reactions is about 67%. Electrode material may be removed from the creases to facilitate folding. It is noted that the roles of the positive and negative electrodes may be reversed. That is, a central negative electrode may be disposed between two positive electrodes.

It is noted that in the fifth embodiment (Variation 4) shown in Figure 5, the surfaces of the negative electrodes 6 that are folded over on themselves and not utilized in the charge discharge



reaction of the electrode can still be utilized to advantage as recombination surfaces. This is best achieved through the use of a hydrophobic layer inserted into the folds on each side of the zigzag configuration. This is shown in Figure 6A where hydrophobic layers 28 are inserted within the folds of the trielectrode stack. This can also be done by encasing the trielectrode stack between two hydrophobic layers 28 prior to the folding operation. Figure 6B shows the trielectrode stack that includes the positive electrode 4 and the two negative electrodes 6 on both sides of the positive electrode 4. The trielectrode stack is sandwiched between two hydrophobic layers 29.

It may also be possible to utilize the back sides of the negative electrodes as an electrolyte reservoir by encasing the trielectrode stack between two separators (to form a "separator wrap"). To best retain the ability to use the back sides as recombination surfaces, it may be useful to coat the back sides of the negative electrodes with a hydrophobic coating such as PTFE. Additionally, for the same reason, it is preferred that this outside separator wrap be less hydrophilic (or more hydrophobic) than the electrochemically active electrode separators that are inserted between positive and negative electrodes. The electrochemically active

electrode separators (inserted between positive and negative electrodes) are usually treated to provide for a hydrophilic nature since the polyolefin materials typically used are hydrophobic by nature. Thus, a less hydrophilic version (useful for the separator wrap) can be made by elimination or reduction of the hydrophilic treatment.

Parts count reduction over the conventional prismatic design is an important objective of this invention. Another objective is high utilization of the electrode surfaces. The table below shows the parts count for the invention and variations in comparison to conventional prismatic cells.

	Part Count	Surface Utilization
Prismatic cells	N	100%
Bielectrode zigzag stack	2	50%
Variation 1	$N/2 + 1$	100%
Variation 2	$N/2$	100%
Variation 3	$N/4 + 1$	100%
Variation 4	3	67%

The bielectrode zigzag stack (Figures 1A and 1B) and the 4 variations all provide for substantially reduction in parts count over the conventional

prismatic cell design. The most substantial reductions were with the base case, bielectrode zigzag stack (as shown in Figures 1A and 1B), and Variation 4. Variation 4 provides a higher power approach due to  
5 more complete utilization of electrode surface area and also provides surface area of recombination allowing for a robust low pressure design.

Another aspect of the present invention involves folding of the electrode into a zigzag configuration.  
10 At the fold point or crease, it may be difficult to maintain the integrity of the active material, which may tend to delaminate at the tight radius of the folds. One way to avoid this is provide strips of substrate at regular intervals that are not loaded with  
15 active material. The electrode stack could then be folded at these fold points. For example, a metal foam substrate could be pre-calendared to minimized loading of active material in the fold region. In another example, expanded metal substrate could be fabricated  
20 with an integral non-expanded region to avoid active material loading.

Yet another aspect of the present invention involves the connection of the electrodes to the battery cell terminals. One approach would be to weld a  
25 positive electrode tab to an edge of each of the positive electrodes and a negative electrode tab to an

opposite edge of each of the negative electrodes. The positive electrode tabs can be collected to a positive terminal and the negative electrode tabs can be collected to a negative terminal. This is similar to  
5 what is now conventionally done with high-power cylindrical cells. As noted, the positive electrode tabs and terminal would be in an oriented oppositely from the negative electrode tabs and terminals.

In a novel approach, utilizing the zigzag  
10 electrode stack concept, current collection could be achieved by connection to the fold lines or creases in the zigzag stack. Current collection is rotated 90 degrees in this case. In some cases this avoids the use of a separate current collector strip. For  
15 example, with the bielectrode zigzag stack (as shown in Figures 1A and 1B), the positive and negative electrodes can be separately collected along the fold lines or creases on opposite sides of the electrode stack. Figure 7 shows the basic bielectrode zigzag  
20 stack from Figure 1A. In this case, positive electrode tabs 30A are affixed (preferably welded) to the fold lines or creases 12A of the positive electrode 4. Likewise, negative electrode tabs 30B are affixed (preferably welded) to the fold lines or creases 12B of  
25 the negative electrode 6. The accordion shaped structure shown in Figure 7 will be further compressed

down to fit into a prismatic case. The positive tabs 30A will preferably all be connected to a positive terminal while the negative tabs 30B will preferably all be connected to a negative terminal.

5           Figure 8 again shows the Variation 4 from Figure 5 with the fold lines (shown as fold lines or creases 12B in Figure 8) vertically oriented. In this case, each fold line or crease 12B is the fold line or crease of one of the two negative electrodes 6. Hence, the  
10 negative electrode current can be collected by placing negative electrode tabs 30B at the fold lines on both sides of the zigzag electrode structure. The positive electrode current can be collected from the top edge 40 of the positive electrode 4. The positive electrode  
15 current can also be collected from the bottom edge of the positive electrode 4 (not shown). The accordion shape of the zigzag configuration may be further compressed to appropriately fit into a prismatic case.

In another approach, aimed at more facile folding  
20 and better current collection, wires can be connected to the electrode belt at regular intervals. They can then become a bending radii for fold points on the belt that are free from active material. The wires also extend beyond the surface of the electrode for  
25 collection and connection to the current collectors and battery cell terminals. Figure 9A shows an electrode

belt 45 with wires 50 connected at the fold points 47. Figure 9B is an example of the basic bielectrode zigzag stack from Figure 8 wherein the fold lines 12A of the positive electrode 4 and fold lines 12B of the negative electrode have been vertically oriented. Flexible wires 50A are affixed (preferably welded) to the fold lines 12A of the positive electrode 4 to form the positive electrode connections. Likewise flexible wires 50B are affixed (preferably welded) to the fold lines 12B of the negative electrode 6 to form the negative electrode connections. Preferably, the active material is removed from the fold lines 12A and 12B to facilitate folding and to facilitate the connection of the wires to the fold lines.

The concepts described above are applicable to all electrode chemistries. Active electrode materials may be divided into positive electrode materials and negative electrode materials. Examples of positive electrode materials are powders of lead oxide, lithium cobalt dioxide, lithium nickel dioxide, lithium nickel dioxide, lithium manganese oxide compounds, lithium vanadium oxide compounds, lithium iron oxide, lithium compounds, i.e., complex oxides of these compounds and transition metal oxides, manganese dioxide, zinc oxide, nickel oxide, nickel hydroxide, manganese hydroxide, copper oxide, molybdenum oxide, carbon fluoride, etc.

Preferably, the positive electrode material is a nickel hydroxide material.

Examples of negative electrode materials include metallic lithium and like alkali metals, alloys thereof,  
5 alkali metal absorbing carbon materials, zinc, cadmium hydroxide, hydrogen absorbing alloys, etc.

Preferably, the negative electrode material is a hydrogen absorbing alloy. Examples of hydrogen absorbing alloys are provided above. It is within the  
10 spirit and intent of this invention that any hydrogen absorbing alloy can be used.

Hence, in particular, the concepts are applicable to nickel-metal hydride batteries where the negative  
15 electrode includes a hydrogen storage alloy active material and the positive electrode includes nickel-hydroxide active material. Also, in particular, the concepts are applicable to chemistries such as lithium and lithium-ion batteries where high surface is needed  
20 for high power.

The electrodes may be formed by affixing the active materials onto a conductive substrate. The conductive substrate may be any type of conductive support for the active material. Examples of substrates include  
25 expanded metal, wire mesh, metal grid, perforated metal, plate, foil and foam. The actual form of substrate used may depend upon whether the substrate is used for the

negative or the positive electrode, the type of active material used, whether it is a paste-type or a non-paste-type electrode, etc. Preferably, an expanded metal is used for the base electrode of the present  
5 invention. The conductive substrate is preferably formed from a metal such as copper, a copper alloy, nickel, or a nickel alloy. Commonly assigned U.S. Patent Nos. 5,851,698 and 5,856,047, the contents of which are incorporated by reference herein, disclose  
10 negative metal hydride electrodes comprising a substrate made from substantially pure copper.

The active material may be affixed to the conductive substrate in different ways. For example, the active material may be compacted onto the substrate  
15 (rolling mills may be used to perform the compaction). Alternately, the active material may first be formed into a paste by adding water and a "thickener" such as (PVA), carboxymethyl cellulose (CMC) or hydroxypropylmethyl cellulose (HPMC) or the like to the  
20 active composition. The paste is then applied to the substrate to form the base electrode.

As noted above, the zigzag and bifold electrodes may be placed into prismatic cases to form prismatic electrochemical cells. It is also conceivable that the  
25 zigzag and bifold electrodes be placed into the cell compartments of a monoblock battery case to form a monoblock battery. Examples of monoblock batteries are provided in U.S. Patent Application Serial Number 09/139,384 which is incorporated by reference herein.



Another example of a monoblock battery is provided in U.S. Patent Serial Number 09/670,155 which is incorporated by reference herein.

It is to be understood that the disclosure set forth herein is presented in the form of detailed embodiments described for the purpose of making a full and complete disclosure of the present invention, and that such details are not to be interpreted as limiting the true scope of this invention as set forth and defined in the appended claims.

We claim:

1. An electrochemical cell, comprising:  
at least one positive electrode;  
at least one negative electrode; and  
5 an electrolyte,  
wherein said at least one positive electrode and/or  
said at least one negative electrode folded in a zigzag  
configuration.
- 10 2. The electrochemical cell of claim 1, wherein said  
at least one positive electrode comprises a nickel  
hydroxide material.
3. The electrochemical cell of claim 1, wherein said  
15 at least one negative electrode comprises a hydrogen  
storage alloy material.
4. The electrochemical cell of claim 1, wherein said  
electrolyte comprises an alkaline material.
- 20 5. The electrochemical cell of claim 1, wherein said  
alkaline material comprises an aqueous solution of an  
alkali metal hydroxide.

6. The electrochemical cell of claim 1, wherein said at least one positive electrode and said at least one negative electrode are disposed in a prismatic case.

5 7. An electrochemical cell, comprising:

an electrode stack including a positive electrode and a negative electrode, said electrode stack folded in a zigzag configuration having folds and creases; and an electrolyte.

10

8. The electrochemical cell of claim 7, wherein said at least one positive electrode comprises a nickel hydroxide material.

15 9. The electrochemical cell of claim 7, wherein said at least one negative electrode comprises a hydrogen storage alloy.

10. The electrochemical cell of claim 7, wherein said 20 electrolyte comprises an alkaline electrolyte.

11. The electrochemical cell of claim 7, wherein said electrolyte comprises an aqueous solution of an alkali metal hydroxide.

25

12. The electrochemical cell of claim 7, further comprising electrode tabs attached to the creases of said electrode stack.
- 5 13. An electrochemical cell, comprising:  
an electrode folded in a zigzag configuration having folds and creases;  
at least one counter-electrode disposed within one or more of the folds of said electrode; and  
10 an electrolyte.
14. The electrochemical cell of claim 13, wherein said electrode is a positive electrode and said counter-electrode is a negative electrode.
- 15 15. The electrochemical cell of claim 13, wherein said electrode is a negative electrode and said counter-electrode is a positive electrode.
- 20 16. The electrochemical cell of claim 14, wherein said positive electrode comprises a nickel hydroxide material.
17. The electrochemical cell of claim 14, wherein said  
25 negative electrode comprises a hydrogen storage alloy.

18. The electrochemical cell of claim 15, wherein said positive electrode comprises a nickel hydroxide material.
- 5 19. The electrochemical cell of claim 15, wherein said negative electrode comprises a hydrogen storage alloy.
20. The electrochemical cell of claim 13, wherein said counter-electrode is a bifold electrode having a first  
10 leg and a second leg.
21. The electrochemical cell of claim 13, wherein said electrode and said at least one counter-electrode are disposed in a prismatic case.
- 15 22. The electrochemical cell of claim 13, wherein said electrolyte is an alkaline electrolyte.
23. The electrochemical cell of claim 13, wherein said  
20 electrolyte is an aqueous solution of an alkali metal hydroxide.
24. An electrochemical cell, comprising:  
an electrode folded in a zigzag configuration  
25 having folds and creases; and

at least one bifold counter-electrode having a first leg and a second leg, said first leg and said second leg disposed within a first and a second fold on the same side of the zigzag configuration of said  
5 electrode.

25. The electrochemical cell of claim 24, wherein said electrode is a positive electrode and said counter-electrode is a negative electrode.

10

26. The electrochemical cell of claim 24, wherein said electrode is a negative electrode and said counter-electrode is a positive electrode.

15 27. The electrochemical cell of claim 25, wherein said positive electrode comprises a nickel hydroxide material.

20 28. The electrochemical cell of claim 25, wherein said negative electrode comprises a hydrogen storage alloy.

29. The electrochemical cell of claim 26, wherein said positive electrode comprises a nickel hydroxide material.

25

30. The electrochemical cell of claim 26, wherein said negative electrode comprises a hydrogen storage alloy.

31. The electrochemical cell of claim 24, wherein said  
5 first leg and said second leg are disposed in adjacent folds on the same side of the zigzag configuration of said electrode.

32. The electrochemical cell of claim 24, wherein said  
10 at least one bifold counter-electrode is a plurality of bifold counter-electrodes, each of said bifold counter-electrodes having a first leg and a second leg.

33. The electrochemical cell of claim 32, wherein said  
15 plurality of bifold electrodes are disposed over alternating creases on each side of the zigzag configuration of said electrode.

34. An electrochemical cell, comprising:  
20 a bifold negative electrode having a first and a second leg;  
a bifold positive electrode having a first and a second leg; and

an electrolyte,  
wherein the first leg of said negative electrode is  
disposed between the first and second leg of said  
positive electrode, and the first leg of said positive  
5 electrode is disposed between the first and second leg  
of said negative electrode.

35. The electrochemical cell of claim 34, wherein said  
electrolyte comprises an alkaline electrolyte.

10

36. The electrochemical cell of claim 34, wherein said  
positive electrode comprises a nickel hydroxide  
material.

15 37. The electrochemical cell of claim 34, wherein said  
negative electrode comprises a hydrogen storage alloy.

38. An electrochemical cell, comprising:

20 an electrode stack including an electrode disposed  
between a first and a second counter-electrode, said  
electrode stack folded in a zigzag configuration with  
folds and creases; and  
an electrolyte.



39. The electrochemical cell of claim 38, wherein said electrode is a positive electrode, and said first and second counter-electrodes are each negative electrodes.

5 40. The electrochemical cell of claim 38, wherein said electrode is a negative electrode, and said first and second counter-electrodes are each positive electrodes.

41. The electrochemical cell of claim 39, wherein said  
10 positive electrode comprises a nickel hydroxide material.

42. The electrochemical cell of claim 39, wherein said negative electrodes comprise a hydrogen storage alloy.

15

43. The electrochemical cell of claim 40, wherein said positive electrode comprises a nickel hydroxide material.

20 44. The electrochemical cell of claim 40, wherein said negative electrode comprises a hydrogen storage alloy material.

45. The electrochemical cell of claim 38, further  
25 comprising a hydrophobic material disposed in at least

one of the folds of the zigzag configuration of said electrode.

46. The electrochemical cell of claim 38, wherein said  
5 electrode stack further comprises a first and a second hydrophobic layer, each of said hydrophobic layers disposed on an outer face of a corresponding counter-electrode, said electrode stack folded to form said zigzag configuration.

10

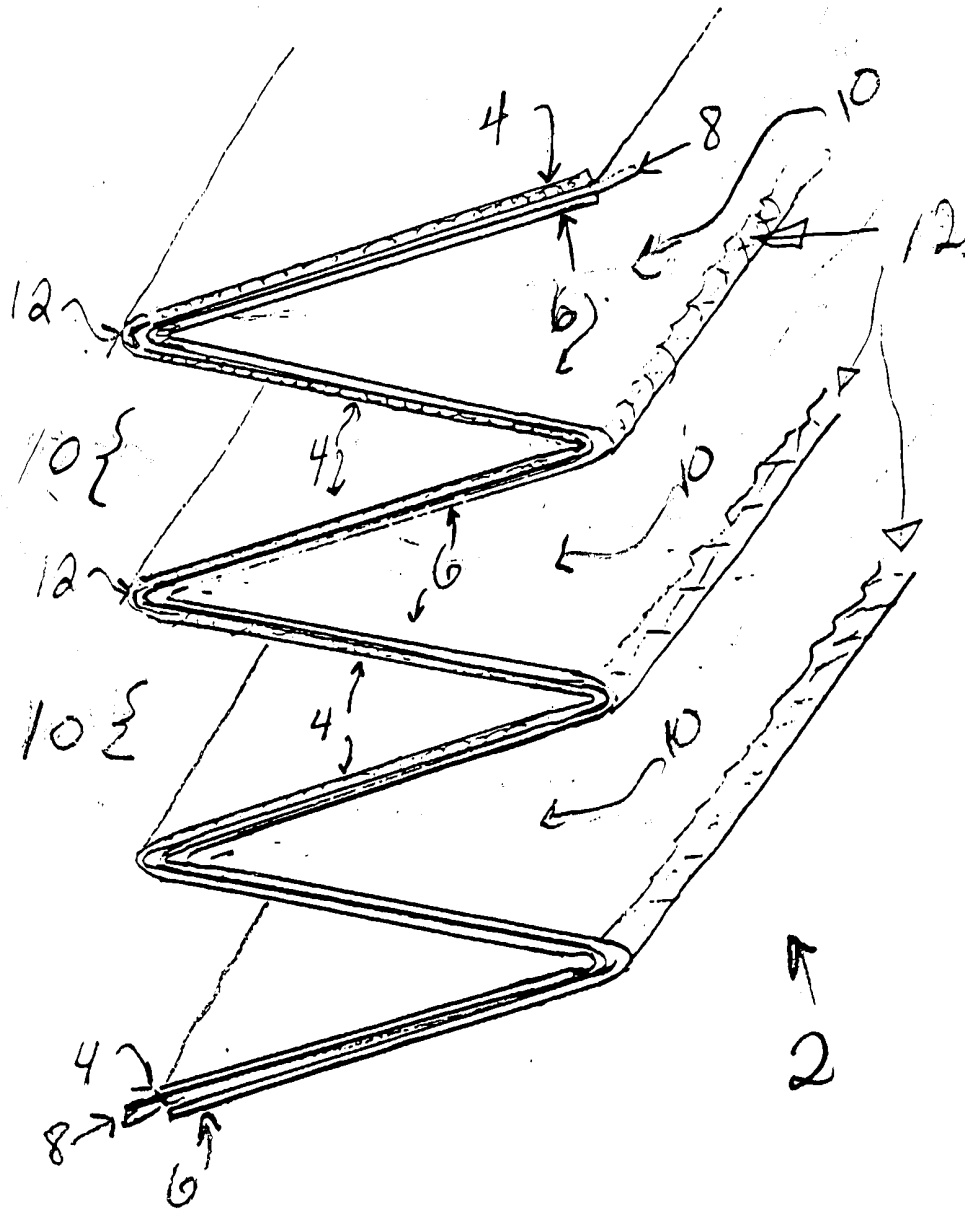

FIGURE 1A



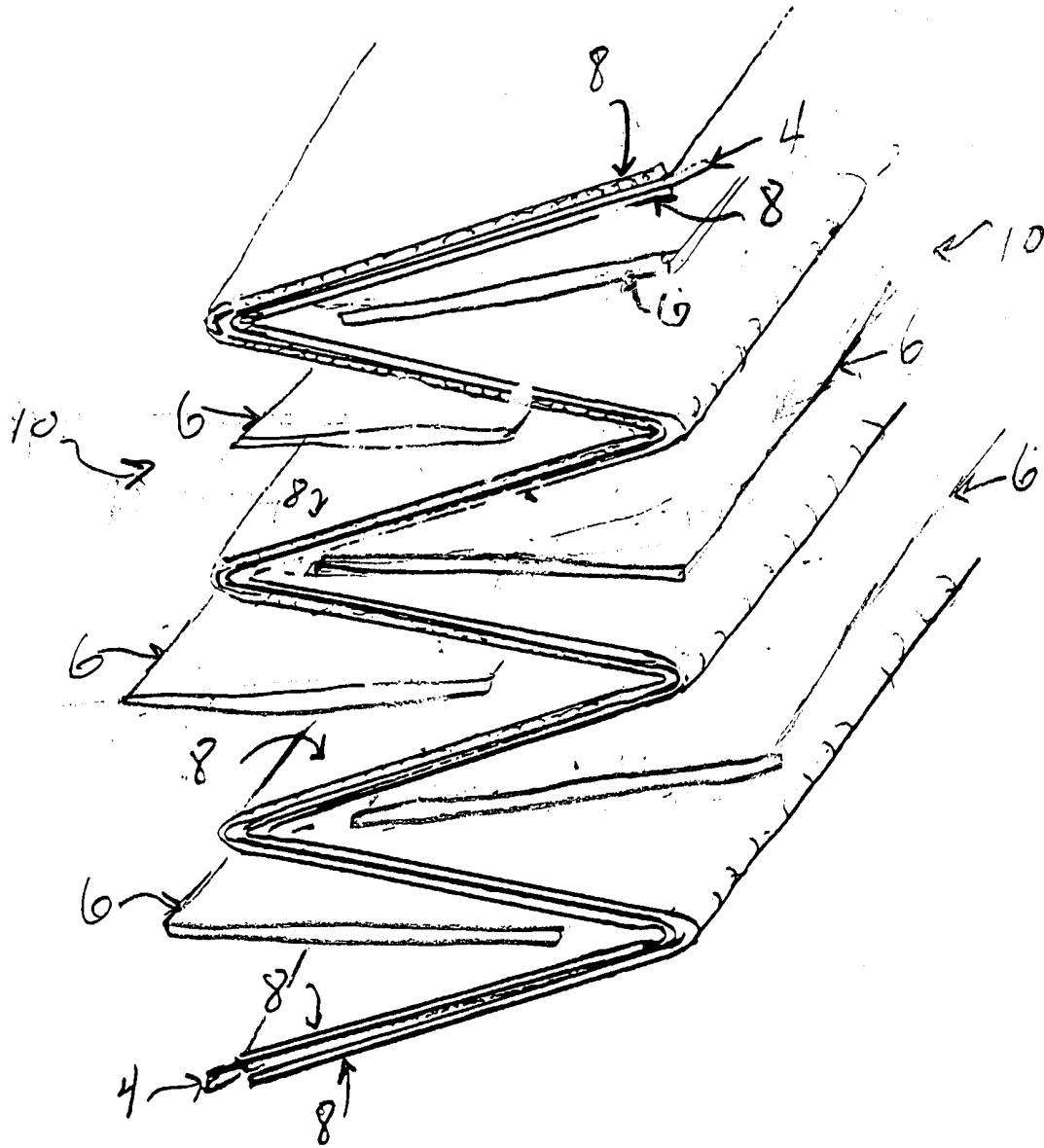

FIGURE 2

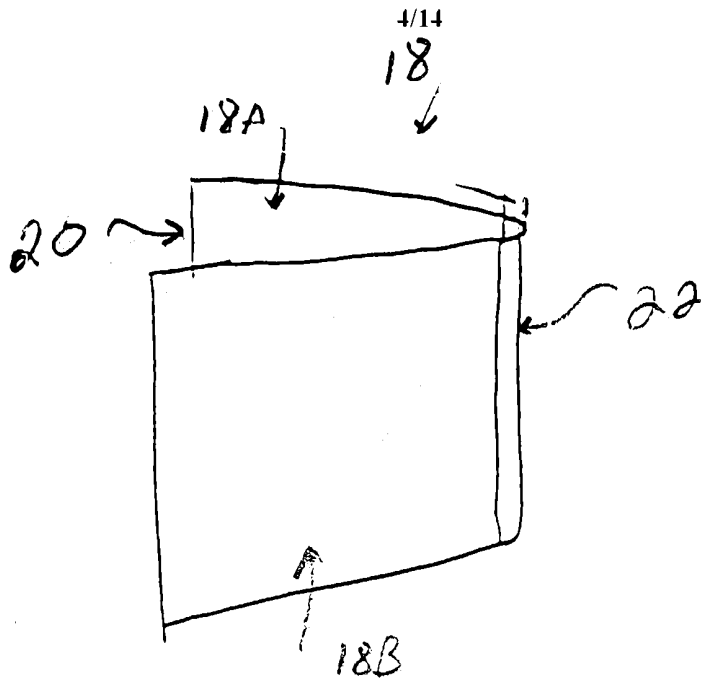

FIGURE 3A

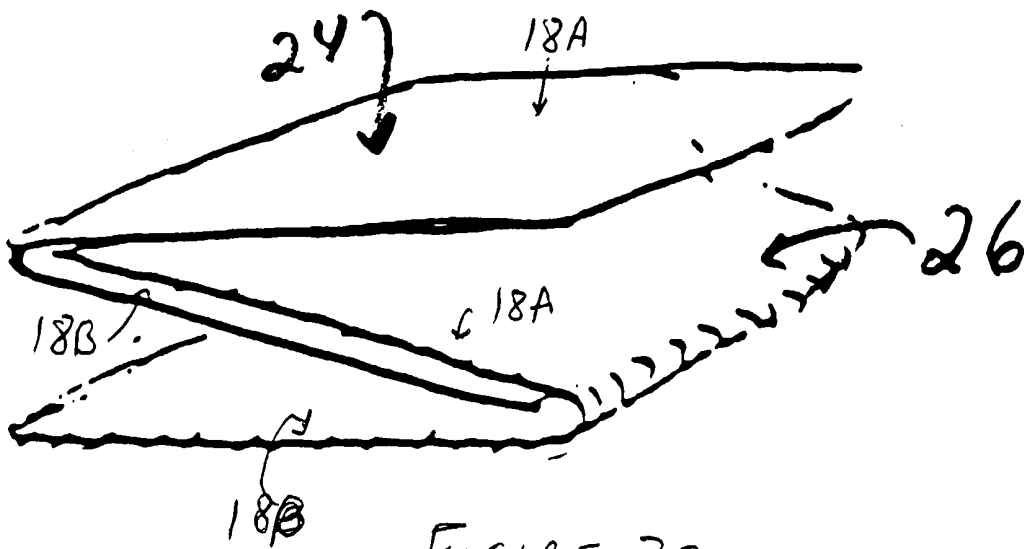

FIGURE 3B

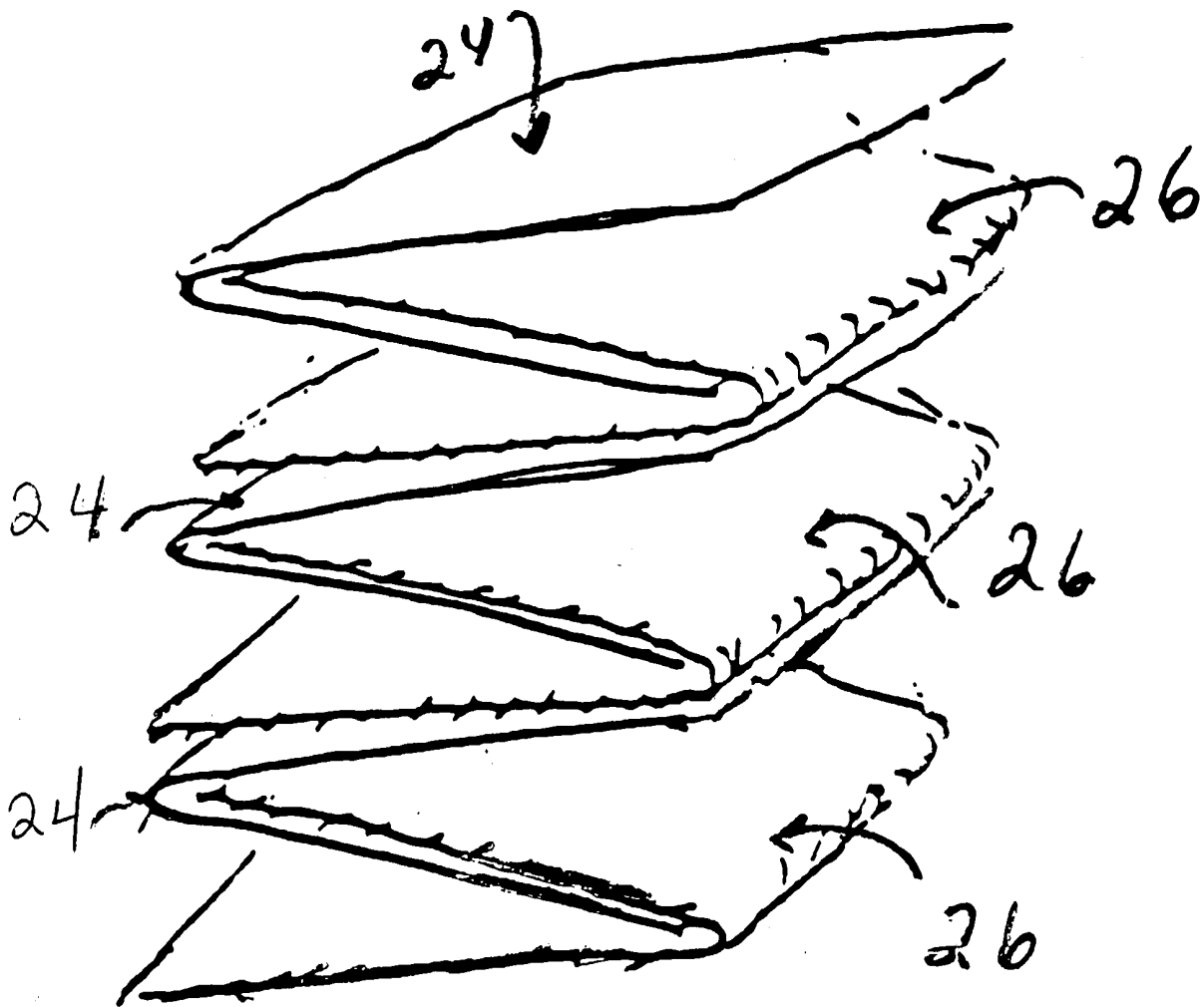

FIGURE 3C

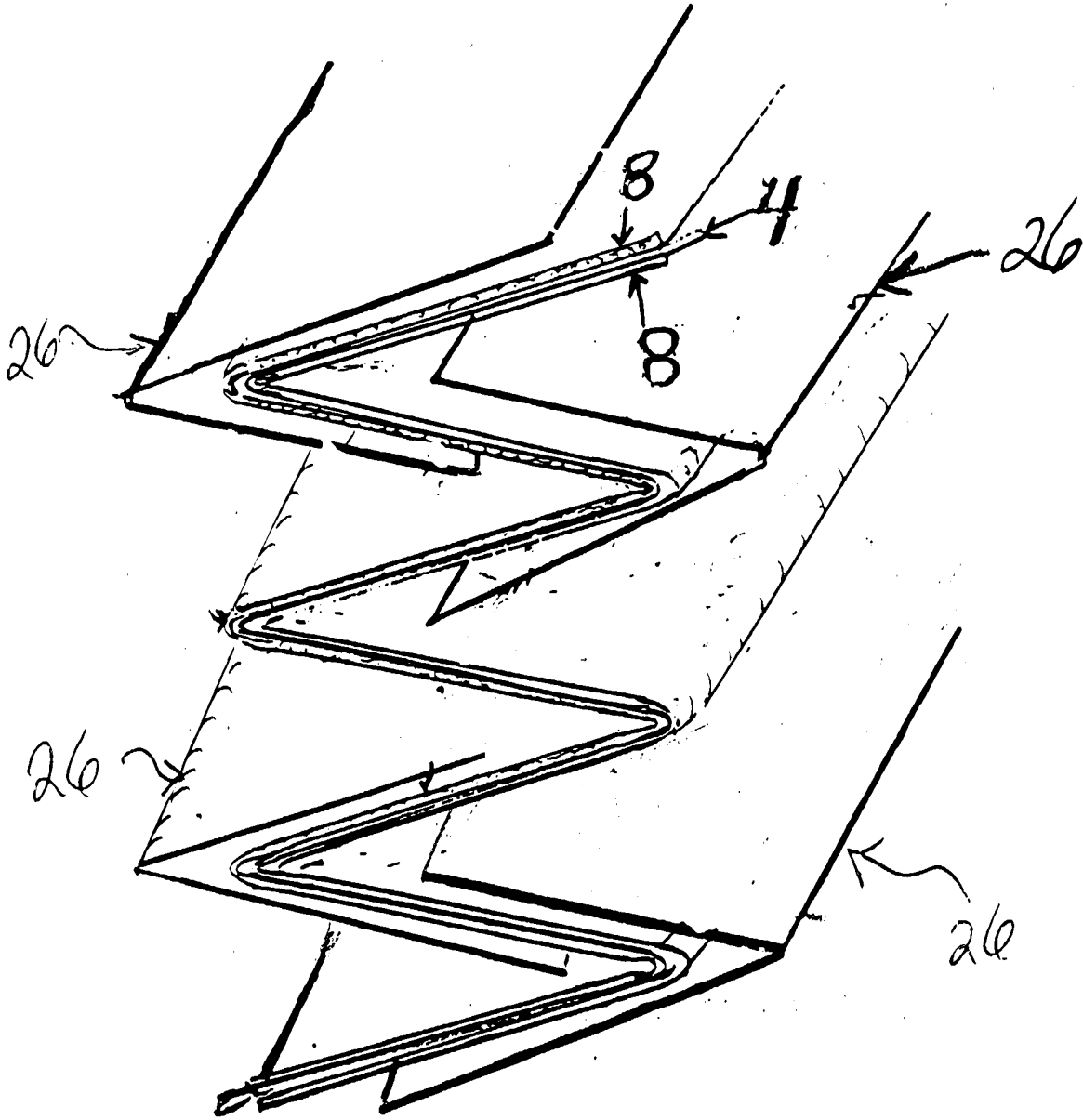

FIGURE 4A



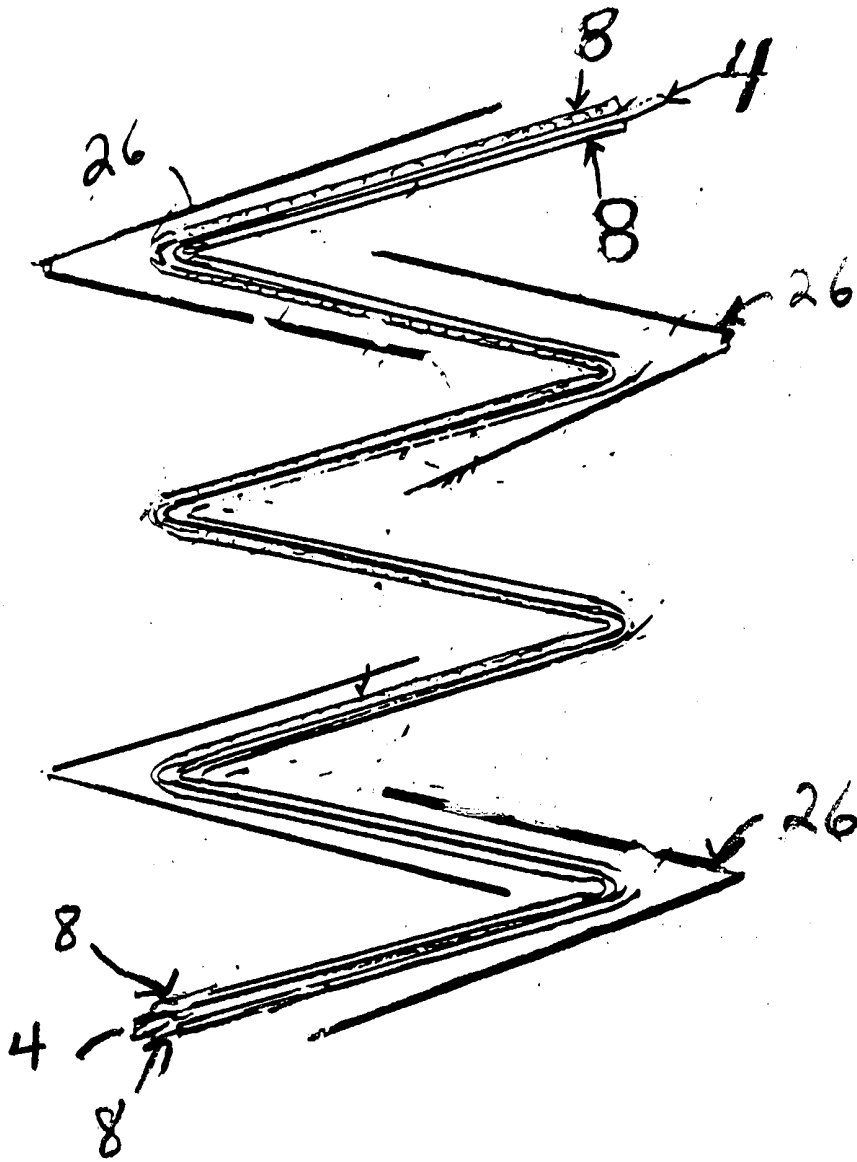

FIGURE 4B

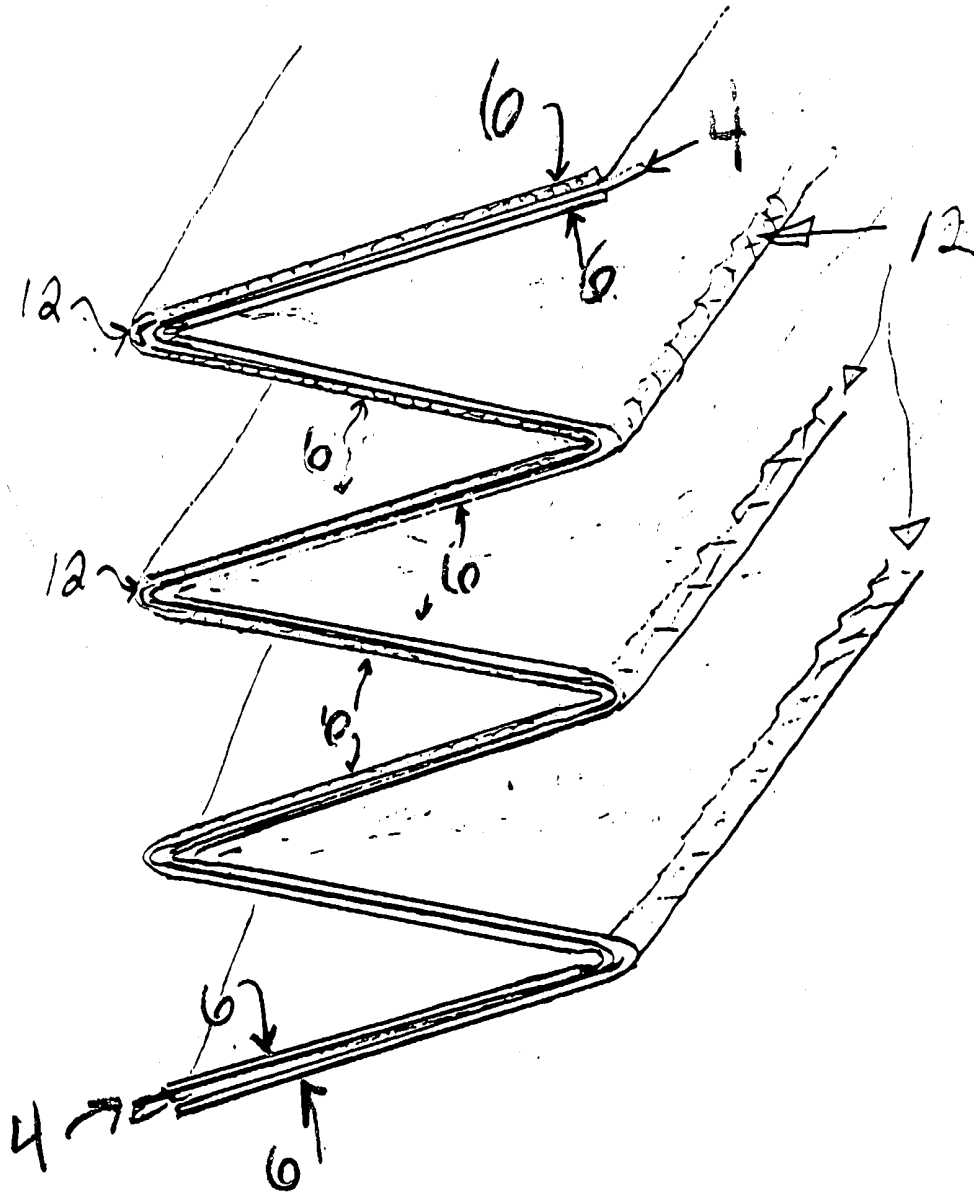

FIGURE 5

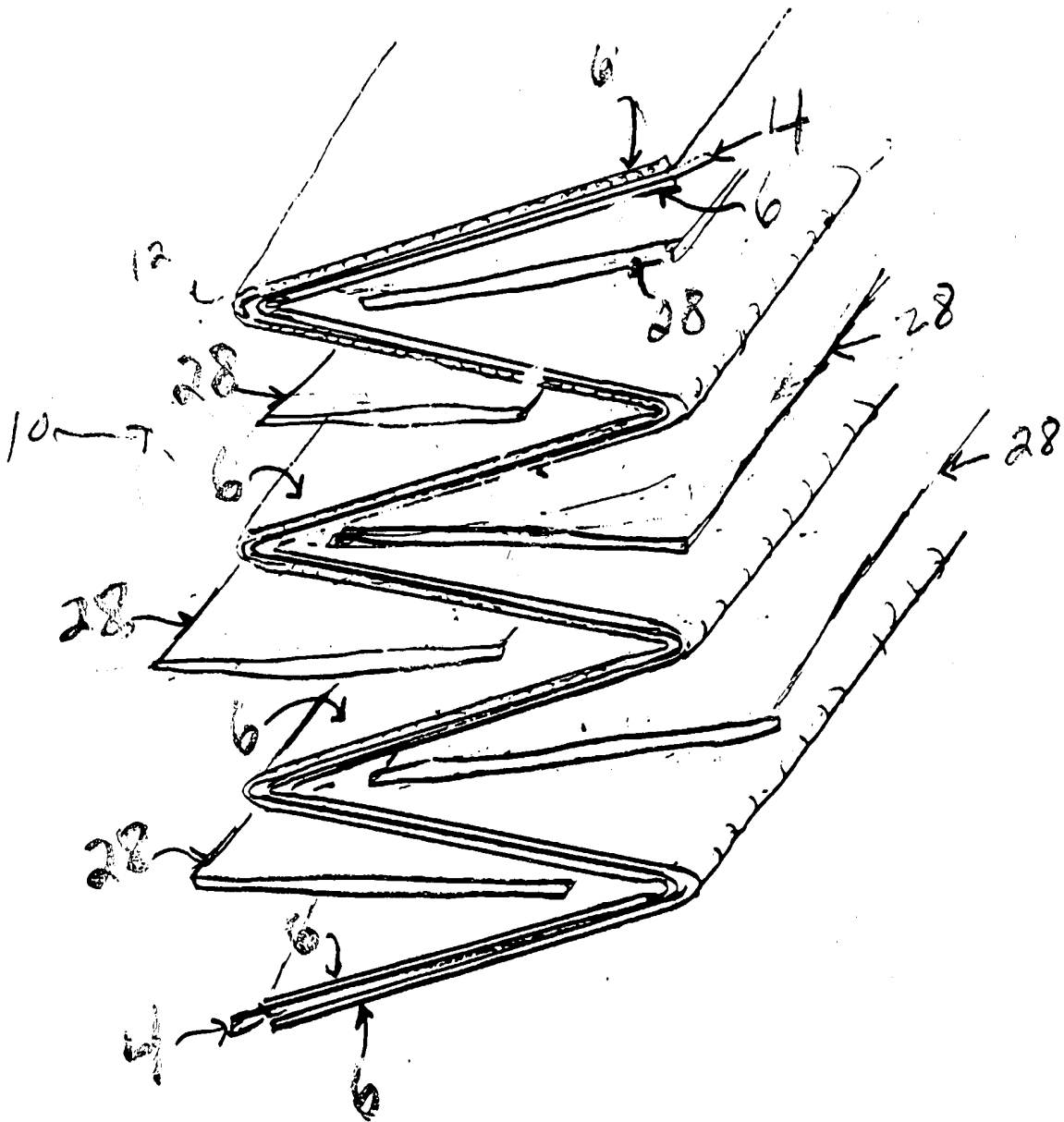

FIGURE 6A

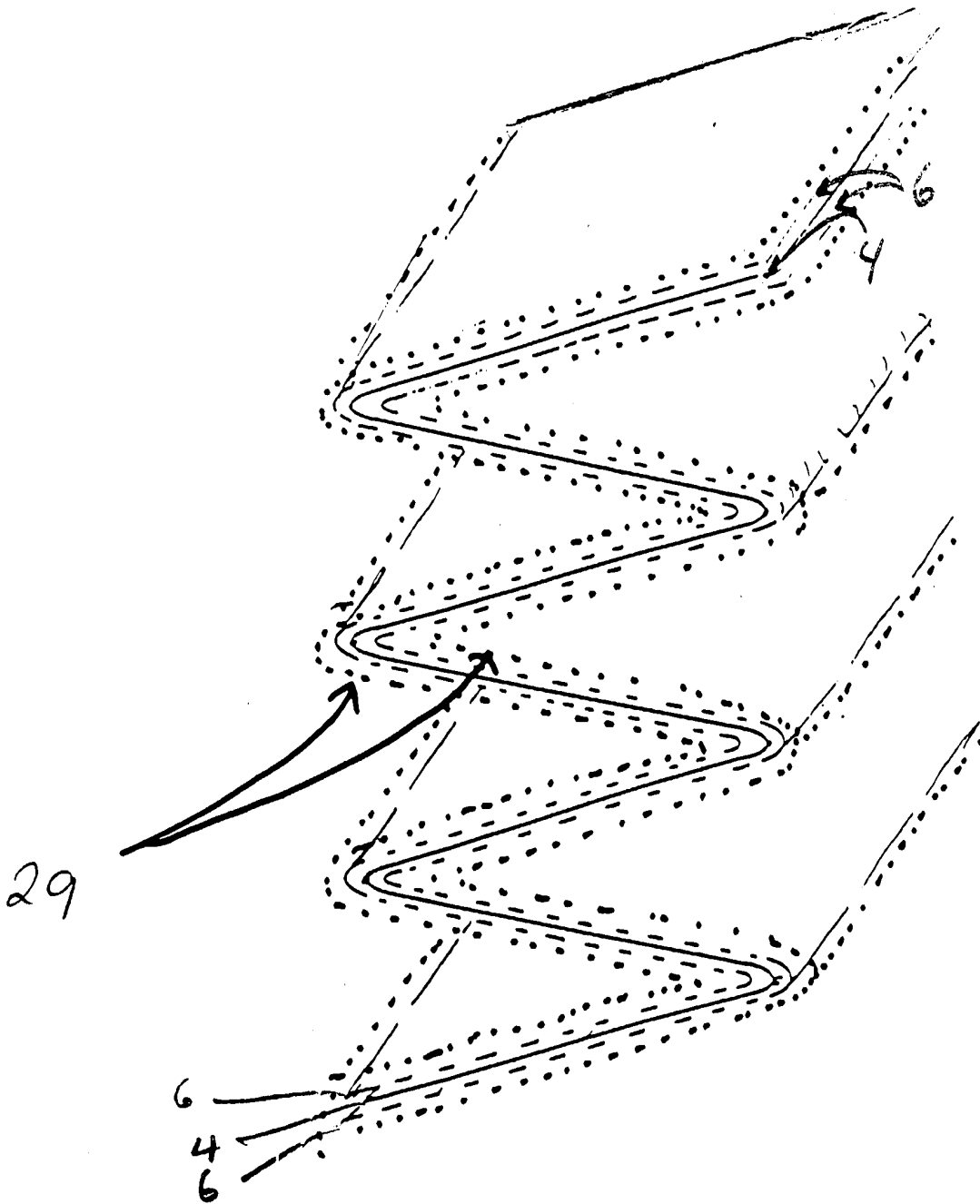

FIGURE 6B

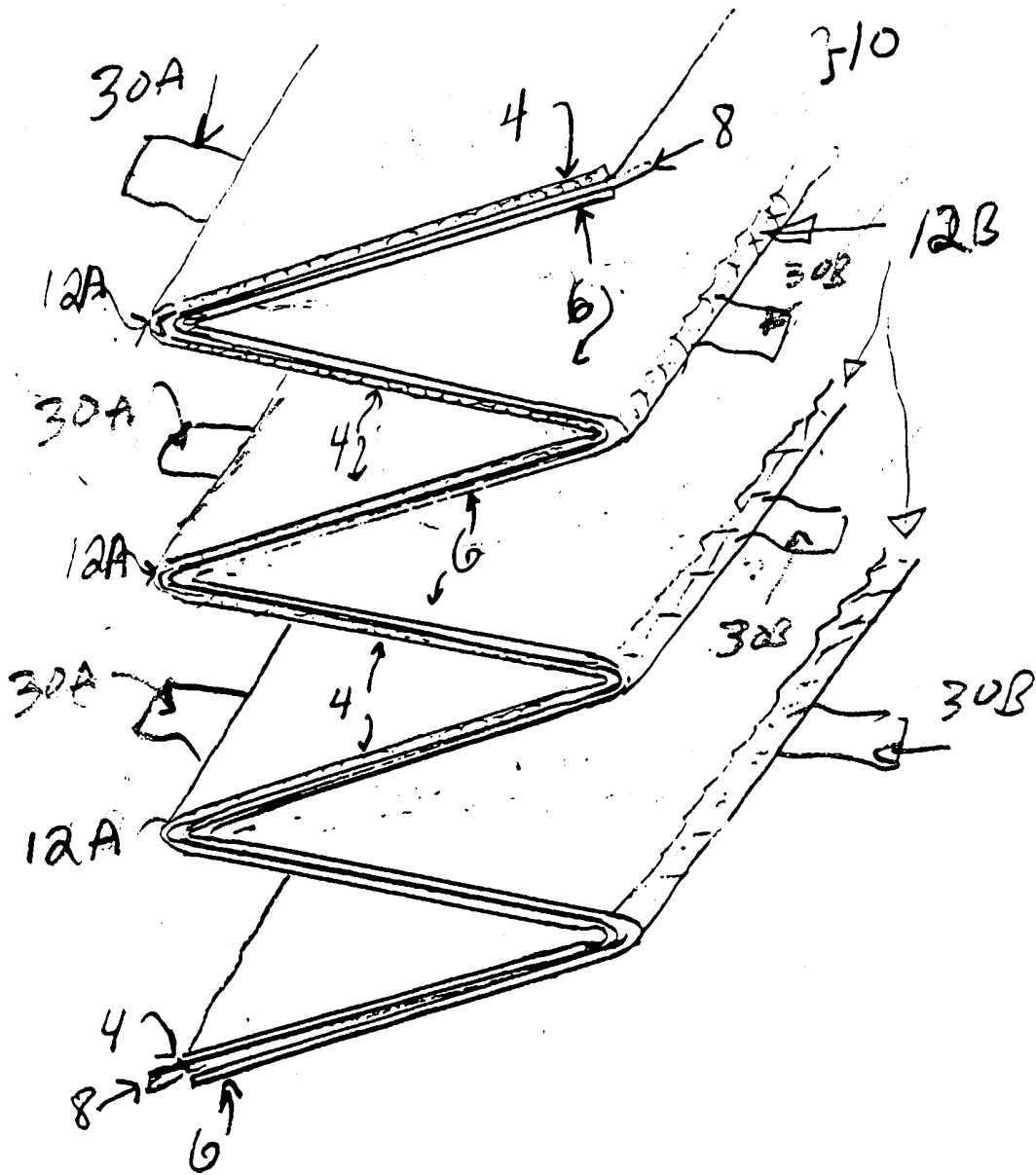

FIGURE 7

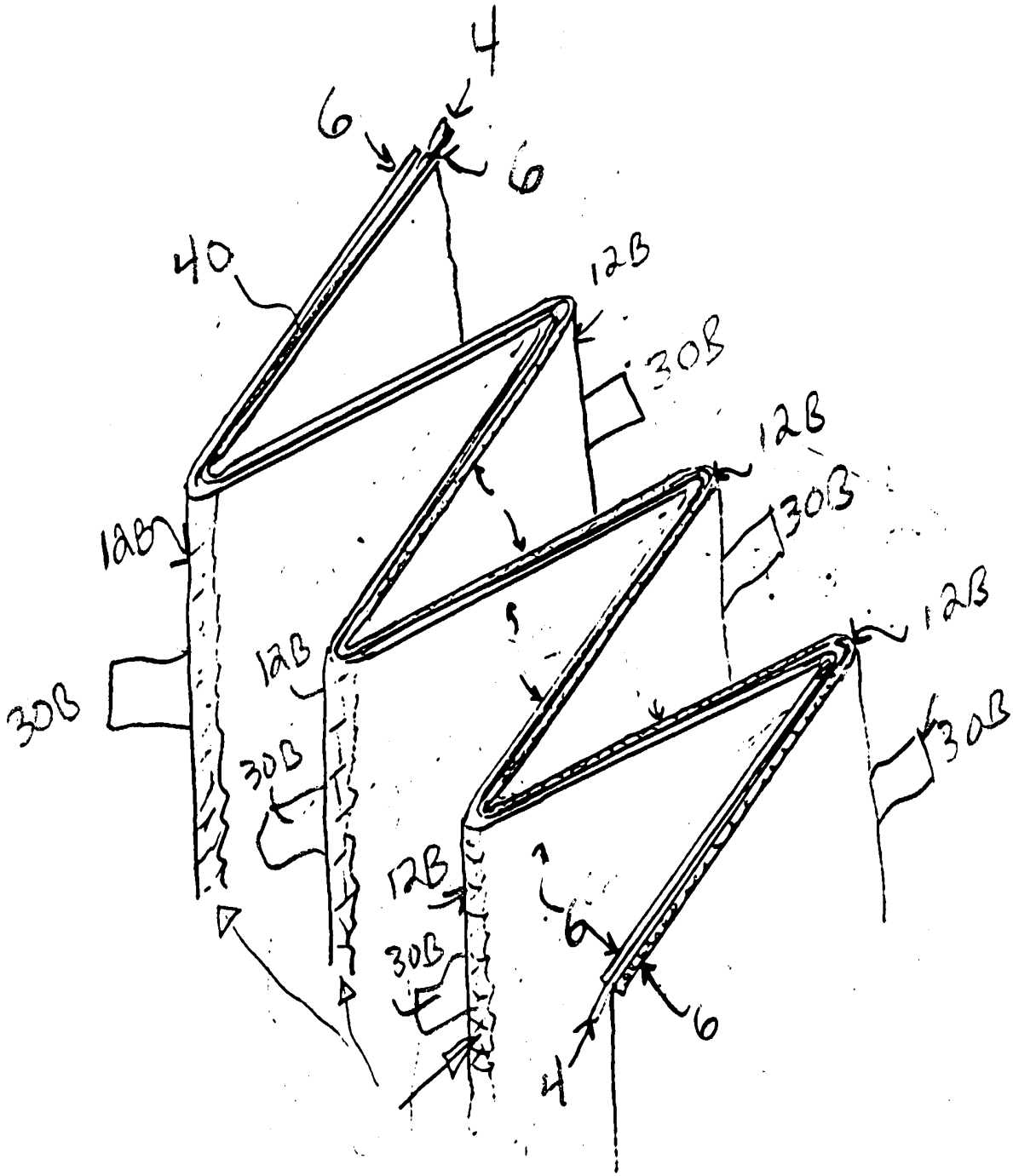

FIGURE 8

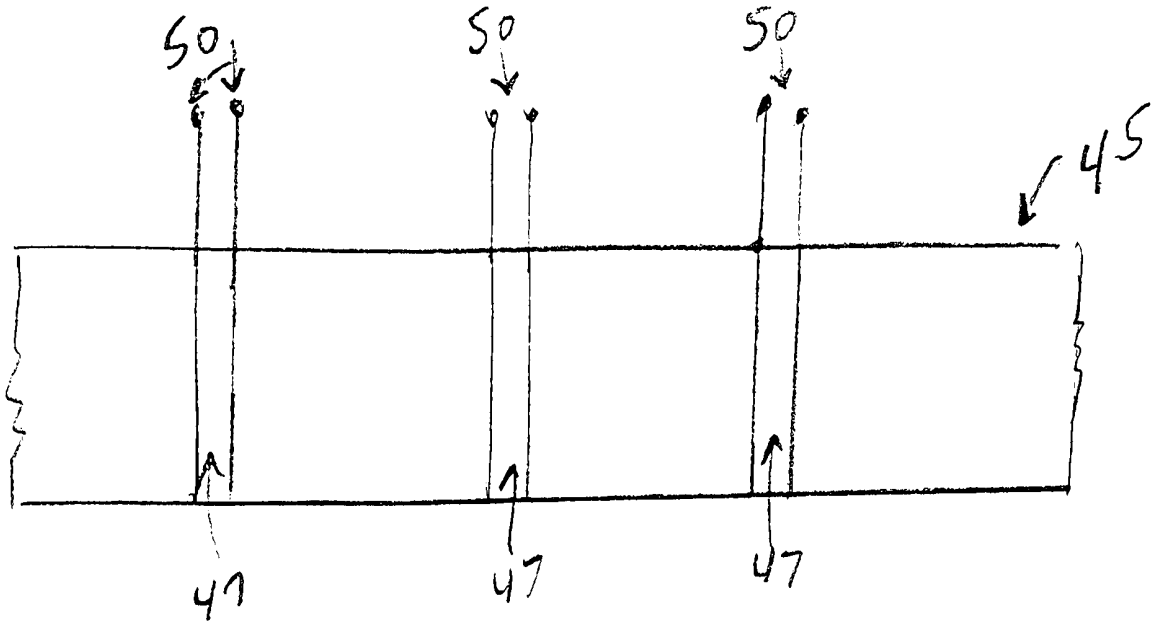

FIGURE 9A

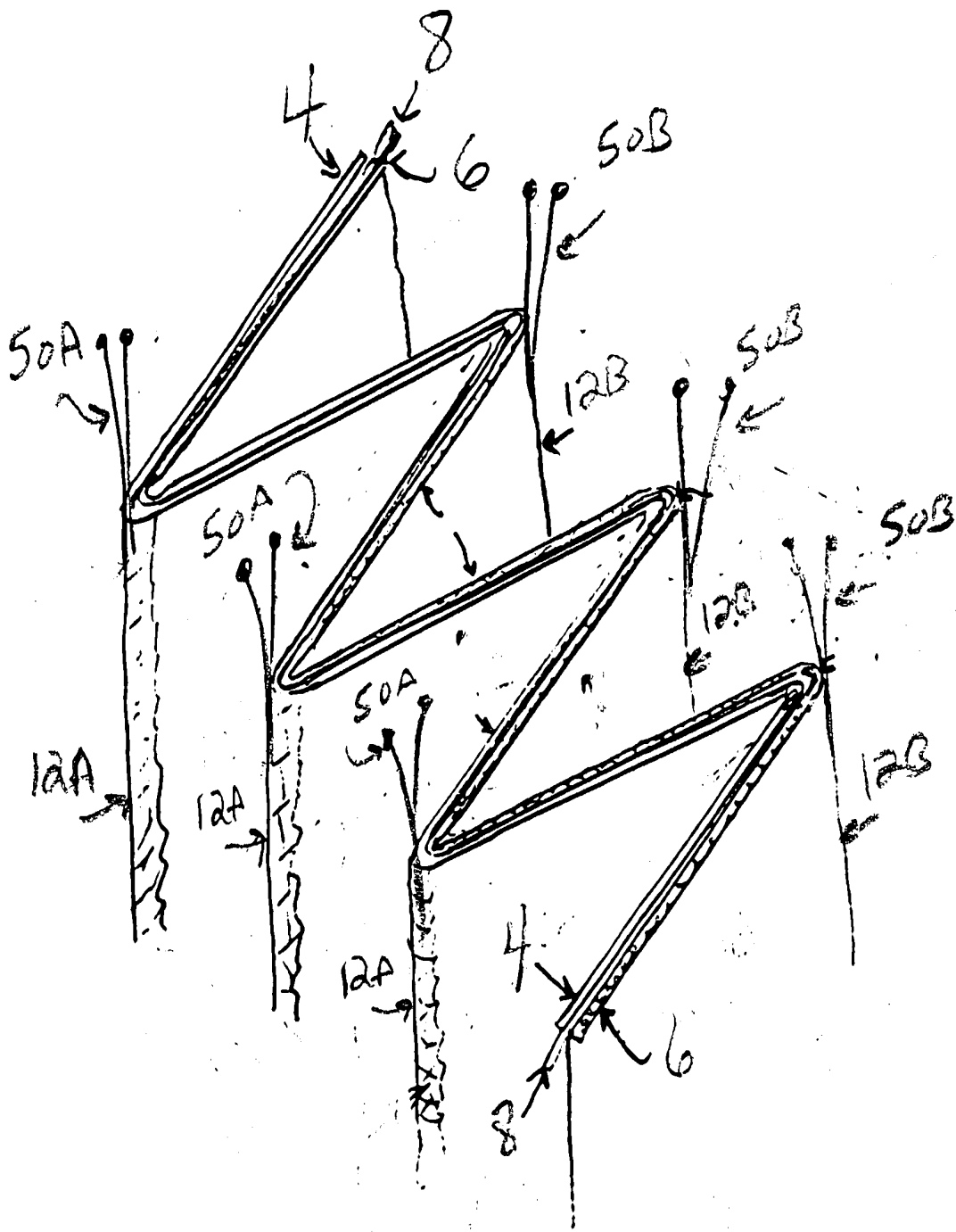

FIG 9B