



INTERNATIONAL APPLICATION PUBLISHED UNDER THE PATENT COOPERATION TREATY (PCT)

<p>(51) International Patent Classification⁴ : B01D 13/01</p>	<p>A1</p>	<p>(11) International Publication Number: WO 89/ 00880 (43) International Publication Date: 9 February 1989 (09.02.89)</p>
<p>(21) International Application Number: PCT/US87/01849 (22) International Filing Date: 28 July 1987 (28.07.87)</p> <p>(71) Applicant (for all designated States except US): MINN-TECH CORPORATION [US/US]; 14905 28th Avenue North, Minneapolis, MN 55441 (US).</p> <p>(72) Inventors; and (75) Inventors/Applicants (for US only) : COSENTINO, Louis, C. [US/US]; 2435 Holly Lane, Plymouth, MN 55447 (US). LEE, Jeffrey, A. [US/US]; 5603 Xylon Avenue North, #316, New Hope, MN 55428 (US). WEST, Daniel, T. [US/US]; 6925 45th Avenue North, Crystal, MN 55428 (US). BURKINSHAW, William, P., Jr. [US/US]; 10201 South Cedar Lake Road, Minnetonka, MN 55343 (US).</p>		<p>(74) Agent: VIDAS, Robert, O.; Vidas & Arrett, 1904 Plaza VII, 45 South Seventh Street, Minneapolis, MN 55402 (US).</p> <p>(81) Designated States: AT, AT (European patent), AU, BE (European patent), BG, BR, CH, CH (European patent), DE, DE (European patent), DK, FI, FR (European patent), GB, GB (European patent), HU, IT (European patent), JP, KR, LU, LU (European patent), NL, NL (European patent), NO, SE, SE (European patent), SU, US.</p> <p>Published With international search report.</p>

(54) Title: FILTER CARTRIDGE

(57) Abstract

A replaceable hollow fiber cartridge filter, including a bundle of hollow fibers (17) of about 8-11 inch length and a porous sleeve (18) surrounding the fibers (17) substantially throughout their length, is positioned in a standardized housing (10) capable of receiving a cartridge of about 2.5 inch O.D. and about 10 to 12 inch length. Cap members (19, 20) are joined to the sleeve at opposite ends, and at least one of the cap members has a coupling (21) for one of a -020 style, -222 style, or a -226 style fitting. Encapsulation seals at least the end of the fibers (17) at the coupling (21) end to one another and to the sleeve member (18) in a fluid tight assembly, while leaving at least the interior of the ends of the fibers (17) adjacent the coupling (21) open.

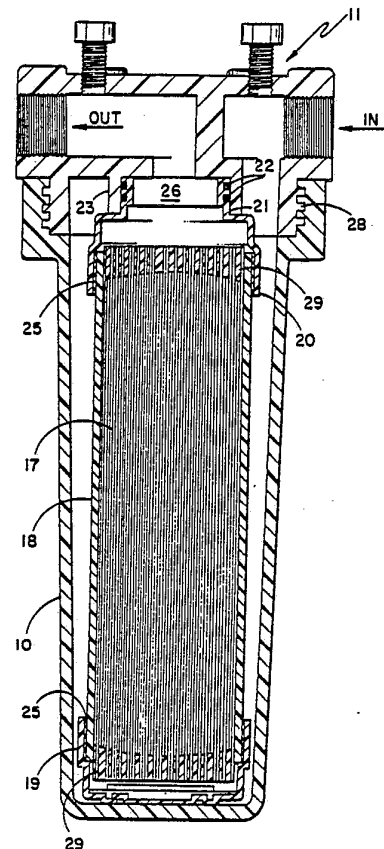

FOR THE PURPOSES OF INFORMATION ONLY

Codes used to identify States party to the PCT on the front pages of pamphlets publishing international applications under the PCT.

AT	Austria	FR	France	ML	Mali
AU	Australia	GA	Gabon	MR	Mauritania
BB	Barbados	GB	United Kingdom	MW	Malawi
BE	Belgium	HU	Hungary	NL	Netherlands
BG	Bulgaria	IT	Italy	NO	Norway
BJ	Benin	JP	Japan	RO	Romania
BR	Brazil	KP	Democratic People's Republic of Korea	SD	Sudan
CF	Central African Republic	KR	Republic of Korea	SE	Sweden
CG	Congo	LI	Liechtenstein	SN	Senegal
CH	Switzerland	LK	Sri Lanka	SU	Soviet Union
CM	Cameroon	LU	Luxembourg	TD	Chad
DE	Germany, Federal Republic of	MC	Monaco	TG	Togo
DK	Denmark	MG	Madagascar	US	United States of America
FI	Finland				

FILTER CARTRIDGEField of the Invention

5 The present invention is directed to hollow fiber filters and more specifically to replaceable filter cartridges of standardized dimension that are provided with substantially universal coupling adapters for inclusion in standard commercial filter housings. More specifically, the invention is to a construction wherein hollow fiber filter element cartridges are provided for the filtration of water , gases and other fluid materials. Multiple improvement over the presently used pleated filter units for commercial housings is achieved.

Prior Art

15 Prior art filter housings have been generally standardized in that they accept typically a cylindrical cartridge of about 3" diameter and from 8" to 12.6" and usually of 10" length. To date such cartridges have used a pleated membrane construction as the filtering element. Filter cartridges using pleated membranes have as a limit the capability of filtering particles equivalent to a molecular weight of (MW) 100,000 or larger. Such pleated membrane cartridges have a connector means for joining to the filter housing piping. The connection consists either of a pipe with external O-rings which is adapted to engage a female connector on the filter housing or a female construction adapted to cooperate with a male extension of the filter housing. The filtering capability of such prior art pleated membrane units has been used for a variety of purposes and in particular for the filtration of water for high purity application such as are used in the semi-conductor industry where very high standards of purity and where large flow volume is desired.

20
25
30
35

The pleated type of replaceable membrane filter element is in the general form of a tube with the outer portions of the folded pleated element defining the external diameter and the internal portions of the accordion pleat forming the internal diameter of the cylinder. Such an element is schematically shown in Fig. 3A and 3B. In such units, the upper and lower bounding surfaces of the pleated membrane must be potted into a liquid impermeable material so as to provide a seal between the internal region of the pleated member and the external region when joined to a filter housing. The outer plastic case housing the pleated membrane unit has openings therethrough so as to permit the water to be filtered to come into contact with the external surfaces of the pleated filter. The internal case portion of the unit that receives the filtered water is similarly a cylinder of a plastic material having openings therethrough. Once the liquid to be filtered has passed through the filter, it collected in this internal cylinder and is then available for distribution to whatever use location one desires.

Pleated membrane filter cartridge elements in accordance with this construction have received widespread usage for many years.

The drawbacks to such pleated units are readily apparent in contrast to the advantages of the present invention. First the total available filtering surface of such an element is severely restricted by contrast with that of the present invention. This can be readily appreciated from viewing Fig. 3a and 3b. A large void region in the shape of a cylinder extends the length of the cartridge for receiving the filtered liquid of the cartridge. This void region does not contribute to filtering. Also, a large void region

exists between the outer surface of the adjacent convolutions that does not contain filtering surfaces. This void area is not present in the present invention. Total available filtering surface is below what is desired for long life and high flow rates. Another serious disadvantage to pleated membrane constructions of the prior art is their tendency to collapse under high differential pressure loads, thus further limiting the filtering capacity of the unit for a given size filter chamber.

10 Summary of the Invention

It is an object of the present invention to provide a replaceable cartridge filter of hollow fiber. The cartridge is constructed and arranged to be usable in standard filter units. The replaceable hollow fiber cartridge filter has a very high efficiency of particle removal, long life and high flow capacity by virtue of its very large surface area available for filtering compared to presently available cartridge filters. This high efficiency is provided in such a way as to utilize a much higher percentage of the total volume in the filter chamber for filtering purposes than has been heretofore available.

Brief Description of the Drawings

25 Fig. 1 is a perspective view of a well-known filtering chamber;

Fig. 2 is a second variety of filtering chamber available in the market;

Fig. 3a is a cross-sectional view of a prior art pleated filter construction;

30 Fig. 3b is a partial sectional view of a pleated prior art filter installed in a filter chamber;

Fig. 4 is a filter chamber in cross-section having positioned therein a filter element in accordance with the invention;

Fig. 5 is a partial cross-sectional view of a filter element in accordance with the invention installed in a filter chamber;

5 Fig. 6 is a sectional view through a filter element in accordance with the invention;

Fig. 7 is a partial cross-sectional view of a joiner of two filter elements of the present invention to double the filter capacity;

10 Fig. 8 is an elevational view of a collar joining member;

Fig. 9 is a partially cross-sectional and elevational view of a cartridge in accordance with the present invention mounted in a filter chamber and including a support means for the cartridge;

15 Fig. 10 is a bottom elevational view of the cartridge of Fig. 9;

Fig. 11 is a elevational view of a cartridge in accordance with the present invention which has a male coupling member and;

20 Fig. 12 is a graph comparing performance characteristics of a filter in accordance with the invention with the same size elements using pleated members used heretofore.

Detail Description of the Preferred Embodiments

25 The present invention is one that meets the multiple requirements of having a readily replaceable hollow fiber filter cartridge possessing the capability of removal of particulate and other substances down to molecules of as low as 1000 MW, high flow volume
30 capacity, an ability to be utilized for an extended periods of time without clogging and one which is capable of being backflushed to even further increase its overall life. It is further, by virtue of its construction, adapted to fit most industry standard
35 filtering chambers without any modification while still

achieving a liquid tight seal between the fluid to be filtered and the filtered fluid. High differential pressures are possible because of the use of hollow fibers as the filtering medium.

5 These multiple advantages defined above are met through the provisions of having a large number of permeable hollow fibers arranged in a parallel array. The individual hollow fibers should comprise sufficient hollow fibers so that the effective filtering surface
10 at the O.D. of the fibers exceeds 15 square feet within the confines of space available for a filter cartridge fitting, the standard filter chambers of industry. For efficiency, the packing density of the fibers is from 40% to 75%. It has been found that if
15 the packing density of the fibers is greater than 75%, it is difficult to assure that a liquid tight seal is in existence between each fiber to isolate the external pre-filtered material from the internal regions where flow takes place of the filtered material. Below about
20 40% packing density, the hollow fibers have excessive amounts of space therebetween lessening the overall filtering capacity. Packing density is defined as that percentage of the total cross-sectional area in the encapsulating region occupied by the combined cross-
25 sectional area of the hollow-fibers.

Very large numbers of hollow fibers are desirable. The number possible is dependent upon the O.D. of the individual fibers and upon the cross-sectional space available. The number is also
30 dependent on the packing density as defined above. In order to insure desired volume flow of greater than 0.1 gallons per minute of water through a filter which retains particles larger than molecules of a molecular weight of 1000 at a pressure differential of about one
35 psi and at room temperature it is desirable to have the

available filtering surface equal to or greater than 15 square feet. In actual units surface area of the hollow fibers available for filtering have been as large as 89 square feet for a standard size cartridge.

5 Filter cartridges in accordance with the invention can be used for filtering of gases or liquids. One major anticipated use will be in connection with filtering of water. For that reason the invention will be described primarily in connection
10 with that purpose. However, it should be understood that filter cartridges in accordance with the invention can be used for virtually all fluids whether liquid or gaseous. A variety of materials can be used for the hollow fibers. These include polysulfones,
15 polyvinylidene fluoride, cellulose esters, polyethylene, polypropylene and the like. The choice of which type will depend on the materials to be filtered, cost and the like.

It has been found that in order to adapt a
20 unit to fit most of the commercially operating filter chambers, that the hollow fibers should have an overall length from end to end of from 8.5 to 11.5 inches. By maintaining overall length within these dimensions, a filter cartridge can be economically manufactured to
25 adapt to a large number of manufacturers' filter chambers. The external diameter of a cartridge filter in accordance with the invention should be less than 3.3 inches. For uniformity of manufacture, the maximum O.D. of the cartridge is desirably maintained below 3.0
30 inches.

Prior investigators have proposed the use of hollow fibers for filters. For example, Okano et al, Pat. No. 4,547,289 proposes a hollow fiber filter element. In the Okano et al, the invention is directed
35 to a means for visually determining whether leakage has

occurred between a pair of coupling O-rings permitting unfiltered water to bypass the seal means.

The preferred hollow fibers in the present invention are manufactured from polysulfones, although
5 other hollow fiber materials having porosity of the desired level can be used. Further, the present invention utilizes sufficient number of hollow fibers so that the outer surface area for filtering is greater than 15 square feet within an overall replaceable
10 cartridge whose nominal dimensions are 2.7" diameter and 10 length. Flow rates and life before clogging are greatly superior to pleated membrane units within the same dimensions. The advantages of the present invention provides a much more efficient construction,
15 wherein a maximum exposure of hollow fiber surface to the liquid to be filtered is attained with a minimum wastage of hollow fiber surface area. Also, the very large surface area of hollow fibers gives a multiplying of the rate of filtration possible heretofore for
20 standard filter replaceable cartridges of the pleated membrane type. These differences will be more readily apparent after a study of the following descriptions.

Figs. 1 and 2 show the close similarity of two of the overall filter chambers now in use in
25 industry. The chambers consist of an external closed end cylinder 10 having a screw in cap member 11 which is threadedly received into member 10. Suitable O-rings (not shown) are utilized to provide a positive fluid tight seal of cover 11 to base 10. In Fig. 2, a
30 somewhat similar unit is shown which has the same function of the parts identified 10' and 11'.

A third type of filter chamber is conceptually quite similar to Fig. 4 insofar as the connecting means 23 is concerned excepting that a
35 bayonet style locking arrangement is provided for both

the filter chamber element 23 and the connector means 21.

In Figs. 4, 5, and 9, the outer container is designated with the same numbers as with Figs. 1 and 2.

5 Turning to Figs. 3a and 3b, there is shown a cross-sectional view in Fig. 3a of a membrane filter cartridge in accordance with the prior art using pleated membrane 12. This pleated membrane is positioned within the annulus defined by rings 13 and 10 14 which, as can be seen in Fig. 3b, consist of concentric cylinders joined at the top (by member 16) and also joined at the bottom as well to pleated member 12. Cylinders 13 and 14 are both provided with a plurality of openings therethrough so as to allow the 15 water to be filtered to pass onto the surface of and thence through pleated membrane 12 and to be collected in the interior of ring 13. The opposing ends of pleated membrane 12 are potted into a sealing compound 15 at each end thereof so as to allow passage of fluid 20 only through the convolutions of the pleat. Simultaneously there is provided a seal to the chamber walls 14 and top and bottom 16. For a typical 10" long pleated filter cartridge element having a cross-sectional area of about 5.0 square inches, the 25 effective filter area is approximately 5 square feet. This contrasts with filter elements in accordance with the present invention where for the same 10" long element of the same cross-sectional area, the cartridge will have a filter area in excess of 15 square feet and 30 up to about 90 square feet. This great increase in filter area provides rapid flow of filtrate and a longer period of time of operation before clogging. The hollow fiber cartridge also permit much higher differential fluid pressures across the filtering 35 element without the fear of collapse of the walls.

The advantage of a filter element in accordance with the invention is shown in part in Fig. 12 showing flow rates at differential pressures for the invention and for three prior filters of the pleated membrane type in the same size cartridge. As can be seen, the effective flow is several times larger for the cartridges of the invention. The flux of filter cartridges in accordance with the present invention is greater than 0.1 gal/minute at one psi differential pressure at room temperature for water.

Turning now to Fig. 4, there is illustrated a filter element in accordance with the present invention mounted in a filter chamber of the types shown in Figs. 1 and 2. Cap 11 is provided with mating threads to form a threaded junction 28 for closure of the filter chamber. Port means are provided for ingress and egress of water into and out of the system. A female projection 23 extends downwardly from cap member 11 and is designed to mate with a male section of a replaceable filter element. The filter element will typically employ two O-rings 22 to bear against the internal shoulder of member 23 to provide a liquid tight seal therebetween.

The most commonly used filter chambers have two different sizes for the inner diameter of member 23. The first has a 1.0 inch O.D. and the second a 2.25 inch I.D. Coupling cap 21 in the case of the 1.0 inch O.D. filtering will have an I.D. of from 0.975 to 1.04 inches. Two grooves holding O-rings 22 are provided. The grooves for the O-rings can be made to accommodate different size O-rings including those designated -020 and -211. As used herein, and in the chart below, when a designation is made such as -020 Style it is meant as a coupling assembly of a 1.0 inch diameter. Similarly, a -222 Style is to be understood

to be a coupling of 1.75 inch diameter. A -226 Style is to be understood to mean a 2.250 inch diameter coupling. It is not meant to restrict the O-ring sizes to those numerical designations.

5 The filter element in accordance with the invention comprises a large number of hollow fiber members 17. These hollow fibers are positioned within a outer supportive porous sleeve member 18 and are then shallowly potted at the extreme remote ends thereof in
10 a thermosetting potting compound such as polyurethane or epoxy to seal the individual fibers to one another and to the extreme ends of cylinder 18. Cylinder 18 is highly porous to allow ready flow of fluids
tgherethrough. It is stiff enough to support the end
15 caps in spaced relationship and act as a protective shield to the fibers from mechanical damage. The depth of the potting is desirably maintained very shallow commensurate with the necessity of insuring a liquid tight seal between the individual fibers and to the
20 wall of cylinder 18. At the open fiber end 24, the depth of the potting will be about 0.25 inches. Greater depth can be used. However, so long as a seal is obtained no useful purpose is served and greater depth lessens the available filtering surface. The
25 individual fibers can be in a U-shape so that a single fiber extends down and back to create two fibers in cross-section.

After this potting, the upper end 24 of the hollow fibers and the potting is cut to present the
30 open interiors of the individual hollow fibers 17. The lower end of internal portions of the encapsulated ends of the fibers may be opened or they may be left potted depending upon the ultimate use of the individual filter cartridge. The upper end 24 of the now potted
35 fibers is sealingly joined to a member 20 that forms a

CARTRIDGE FILTER SPECIFICATION

Packing Density = 60% Fiber OD = 0.014173 Fiber ID = .01102

HOUSING NAME	HOUSING INSIDE DIAMETER	OVERALL LENGTH	CLEARANCE DIAMETER	FILTER OUTSIDE DIAMETER	EFFECTIVE LENGTH	FILTER NET INSIDE DIA	FILTER NET AREA	NUMBER OF FIBERS	FILTER AREA ID FT ²	FILTER AREA OD FT ²
-222 STYLES (O-rings on Filter) - 1.75" Dia. Mouth										
Filterite Fluoro-plus	3.090	12.500	.092	2.998	10.875	2.718	5.802	22,066	57.7	74.20
Filterite VP-10-3/4	3.100	12.500	.092	3.008	10.875	2.728	5.845	22,229	58.1	74.8
Millipore (with spud)	3.193 3.230	12.625 10.575	.090 .090	3.100 3.140	11.000 8.95	2.820 2.860	6.245 6.424	23,753 24,432	62.8 52.6	80.80 67.6
Ametek #12	3.360	12.375	.085	3.275	10.75	2.995	7.045	26,793	69.2	89.1
Ametek #10	3.400	9.750	.083	3.317	8.125	3.036	7.239	27,531	53.8	69.2
PALL	2.920	11.000	.098	2.822	9.375	2.542	5.075	19,300	43.5	55.9
COMPOSIT (-222)	2.920	9.750	.098	2.822	8.125	2.542	5.075	19,300	37.7	48.5
-020 STYLE (O-rings on housing) - 1.04 " Dia. Mouth										
Gelman Bl.Bowl	3.425	9.875	.083	3.342	8.188	3.062	7.363	28,005	55.1	70.9
Gelman C.Bowl	3.410	10.062	.083	3.327	8.313	3.047	7.292	27,732	55.4	71.3
Filterite LMO-PP (Composit All)	2.875	10.000	.099	2.776	8.062	2.496	4,893	18,608	36.1	46.4
-226 Industrial Style O-rings on filter - 2.250" Dia. Mouth										
Filterite	2.920	12.50	.420	2.50	8.375	2.220	3.870	14,720	29.6	38.1
Pall	2.920	12.50	.170	2.75	8.625	2.470	4.791	18,223	37.8	48.6
Composit (-226)	2.920	12.50	.420	2.50	8.375	2.22	3.870	14,720	29.6	38.1

cap for the hollow fiber and sleeve 18 assembly. A bonding adhesive that sealingly isolates the interior of the fibers from the exterior of the fibers is provided between 18 and 20 and is designated 25. A
5 suitable encapsulant and adhesive is polyurethane.

Cap 20 is provided with a projecting male member 21 which has recesses around the periphery thereof contains O-rings 22.

To maximize the available amount of hollow
10 fiber for filtering and minimize the waste space, a very shallow (generally less than 1/4" of space) is provided above the surface 24 before reaching the male exit region 26. The portion defined by the male exit
21 is desirable kept at as shallow a depth as possible
15 commensurate with providing a positive seal between member 23 and member 21 by means of the O-rings 22.

At the base of hollow fibers 17 and sleeve 18, there is provided a second cap 19 which is
20 closely sealed by means of bonding material 25 at the lower end of the assembly. The hollow fibers 17 will likewise be sealed by the potting compound which is not cut so as to open the interior of the fibers as was described with respect to the upper end. In an
25 alternate construction, the fibers will be cut open at both ends for cascading of cartridges as shown in Figs. 7 and 8. This will be described below.

Turning now to Fig. 5 there is shown an alternative form of the hollow fiber filter cartridge element. In this drawing, like parts will be given the
30 same designation with respect to the earlier discussions. As can be seen in the drawings in this instance, cap member 11' also is provided with threads that screw into cylinder 10'. The cap member 11' has a downwardly projecting member 27 which in this instance
35 is provided with recesses for holding an O-ring 22'.

This contrasts with the earlier description of member 23 which did not have provisions for an O-ring.

The construction of a hollow-fiber cartridge is substantially the same as that described with respect to the cartridge shown in Fig. 4. That is, a plurality of fibers of the same range of pack density as described above is enclosed within a porous cylinder 18. In this instance of Fig. 5, however, the upper cap member 30 is shaped so as to have a downwardly projecting receiving chamber for member 27. That downwardly projecting tube is designated 31. Member 31 projects downwardly from the uppermost regions of the cap 30 to a position from 1/8" to 1/4" above the surface of the open end of fibers designated 24. This provides an ample space for flow of filtrate from the internal portions of fibers 17 to the receiving region within member 27. The opposite ends of hollow fibers 17 may be either sealed as is described with respect to Fig. 4, or as will be described, left open to permit cascading of two or more fiber elements.

In each of the constructions discussed above hollow fibers 17 are desirably ones having an internal diameter of about .011 and an external diameter of .014 to provide a very thin wall. That thin wall is manufactured to contain small openings therethrough. For the most thorough filtering, the openings will be of a size which will not pass materials of a size greater than 1000 MW. The overall length of the units will vary depending upon the ultimate filter chamber into which they are to be placed, but will advantageously be an overall length of 8" to 12.6".

Large diameter hollow fibers may be used. However, the total filtering surface possible is less for a given size cartridge outer dimensions the larger the diameter of the hollow fibers. Smaller diameter

hollow fibers are preferred. As stated previously, the hollow fiber cartridge should have at least 15 square feet of filtering surface to insure flow rates of greater than 0.1 gallons per minute at one psi differential when the filter screens out material greater than that with a size of a molecule of 1000 MW.

Fig. 6 shows a cross sectional view partially filled in for the individual fibers of constructions described with respect to either Figs. 4 or 5. As can be seen, there is no central void area, as is true in the pleated filters of the prior art. Rather all space is substantially used for receiving incoming liquid to be filtered, or for delivery of filtered liquid to the ultimate user.

Shown in the chart below is a description of hollow fiber filter cartridges manufactured in accordance with the teachings of the present invention and specifically identified with respect to the ideal sizes and resulting construction for a variety of filter housing. As previously described above the designations -020 Style, -222 Style, and -226 Style are to be understood to mean connectors of 1", 1.75" and 2.25" diameters respectively and not as limited to those size O-rings.

There are two basic types of housings - one which utilizes O-rings on the filter element itself and the others where the O-ring sealing means is on the pipe of the filter chamber. Also, as is illustrated in the chart, the filter area in square feet runs from 38 sq. feet to a high of 89 sq. feet per fiber filter cartridge. Many of the advantages of the invention are obtained even when the filter area is as low as 15 square feet.

Turning now to Figs. 7 and 8, there will be seen a joining sleeve 32. This joining sleeve has two

widened receiving areas 33 and 34 which are of a size to receive an outer portion of the encapsulated ends of the hollow fibers. The joining sleeve 32 is passed over an upper and a lower end respectively of the encapsulated and sleeved portions of two filter cartridges. The lower portion of the hollow fibers 17 have been sliced through the potting to be also opened as is the top region 24. The sleeve 32 is bonded to the encapsulated ends and sleeve to make a liquid tight seal. Thus there is a cascading of the two elements making a single filter element 20" or more in length for adapting to certain specific filter housings without the necessity of designing and constructing separate cartridge elements to meet this need.

It is occasionally desirable to have the base of the filter cartridge in accordance with the invention bear against a surface at the bottom of chamber 10 or 10'. This is to prevent any internal back pressure in the filter cartridge from disengaging the seal O-rings and thereby result in leakage by reason of movement of the cartridge away from the junction. Also, by use of a restraining annulus 37 in Fig. 9, any tendency for movement in a transverse mode is avoided. As seen in Figs. 9 and 10, this can be accomplished by having a bonded-on tip 35 to the base cap member 19. This member 35 can be selectively joined to a "standard" filter cartridge to adapt it to varying lengths of cylinders 10. The obvious advantages to doing so is to provide a substantially universal cartridge.

While the invention has been described with respect to a specific hollow fiber, it is possible to substantially vary the diameters, both internal and external of the fiber, and to achieve many, if not all, of the advantages of the present invention. That is,

rather than being limited to the specific examples given here wherein the fibers have a O.D. of about .0014" and an O.D. of about .0010", variations from these specific dimensions can be utilized. The general advantage is to use fibers of as small a diameter as possible to maximize the total surface area available. In all events a filter cartridge in accordance with the invention has a filter surface area in excess of 15 square feet.

What Is Claimed Is:

1. A replaceable hollow fiber cartridge filter for use in a standardized filter housing capable of receiving a filter cartridge of about 2.5 inch O.D. and about 10" to 12.6" overall length comprising:

a) a bundle of fluid permeable hollow fibers of effective length of approximately 8 to 11 inches of effective filtering surface;

b) a supportive porous sleeve member surrounding said bundle of hollow fibers substantially throughout their length for supporting and confining said fibers;

c) cap members joined to said sleeve member at opposite ends thereof; at least one of said cap members being provided with coupling means for one of a -020 Style, -222 Style, or an -226 Style fitting;

d) encapsulating means sealing at least the end of said fibers at the coupling means end to one another and to the sleeve member in a gas and liquid-tight assembly; while leaving at least the interior of the ends of said hollow fibers adjacent said coupling means open;

e) said bundle of hollow fibers having a filter surface area greater than about 15 square feet.

2. A replaceable hollow fiber cartridge filter in accordance with claim 1 wherein the packing density of said fibers is from about 40 to 75%.

3. A replaceable hollow fiber cartridge filter in accordance with claim 1 wherein said cartridge filter will pass at least 0.1 gallons per minute of water at a pressure differential across the fiber wall of one psi and at room temperature.

4. A replaceable hollow fiber cartridge filter in accordance with claim 1 wherein the pore openings retain materials having a molecular weight greater than 1000.

5. A replaceable hollow fiber cartridge in accordance with claim 1 wherein each end of said hollow fibers is encapsulated.

6. A replaceable hollow fiber cartridge in accordance with claim 1 wherein both ends of said hollow fibers are open to the interiors thereof and the cap member on the opposite end to said coupling means is an open cylinder and is constructed and arranged to be joined to a second bundle of hollow fibers to form a cascaded cartridge hollow fiber filter.

7. A replaceable hollow fiber cartridge in accordance with claim 6 wherein a second bundle of fibers has a closed cap at the end remote from said open cylinder.

8. A replaceable hollow fiber cartridge in accordance with claim 1 wherein the outer diameter of the cross-section of said hollow fibers is about 2.5 inches and the effective filtering length of said fibers is about 8 inches.

9. A replaceable hollow fiber cartridge in accordance with claim 8 wherein the outside filter surface area of a said hollow fibers is in excess of about 48 square feet.

10. A replaceable hollow fiber cartridge in accordance with claim 1 wherein said coupling means is a pipe extension from said housing having an O.D. of about or slightly less than 1.0 inches and wherein said pipe extension has spaced recesses constructed and arranged to hold O-rings for sealingly pressing against a coupling wall of a filter chamber connector.

11. A replaceable hollow fiber filter cartridge in accordance with claim 10 wherein the coupling means pipe extension has an O.D. of about or slightly less than 1.75 inches.

12. A replaceable hollow fiber cartridge filter in accordance with claim 1 wherein the coupling means on said cap member is a cylindrical tube having an I.D. of slightly greater than 1.0 inches and has smooth walls adapted to cooperate with O-rings on a filter housing connector to effect a seal therewith.

13. A replaceable hollow fiber cartridge filter in accordance with claim 1 wherein the hollow fibers have an O.D. of about 0.014 inches.

14. A replaceable hollow fiber cartridge filter in accordance with claim 1 wherein the O.D. of said cartridge is less than 3.3 inches and the length is less than about 11.4 inches and wherein the effective filter surface area is from about 38 to 89 square feet.

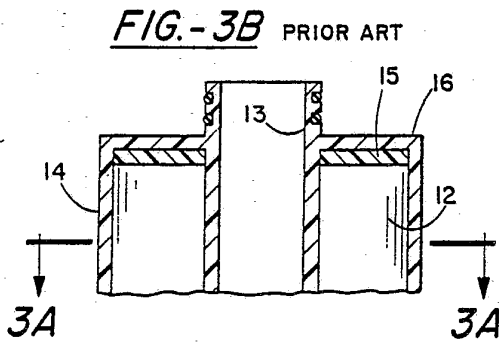
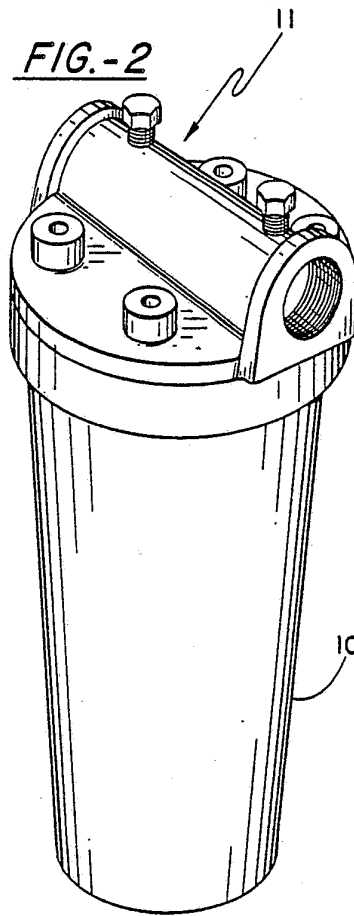
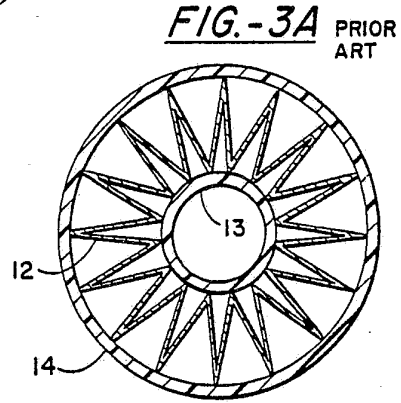
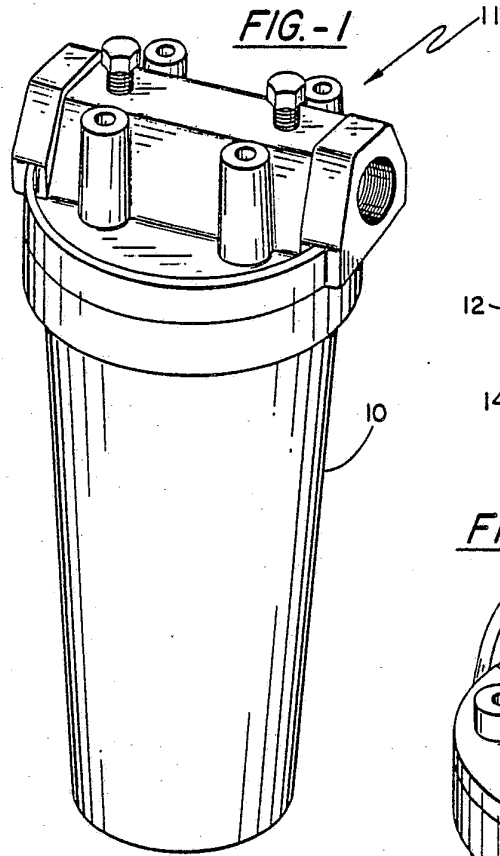

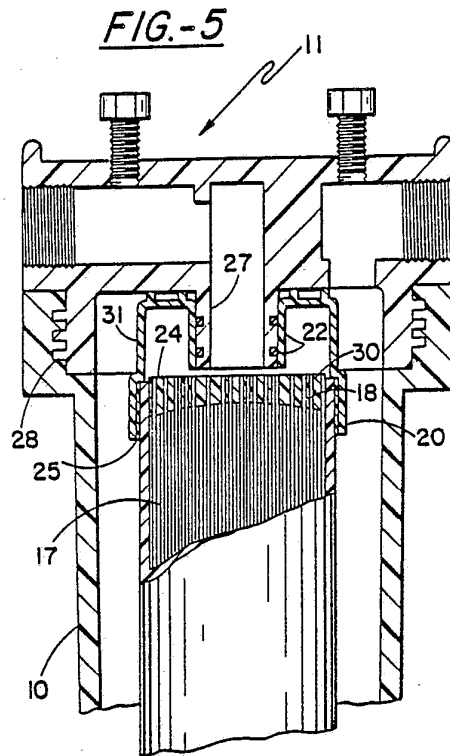
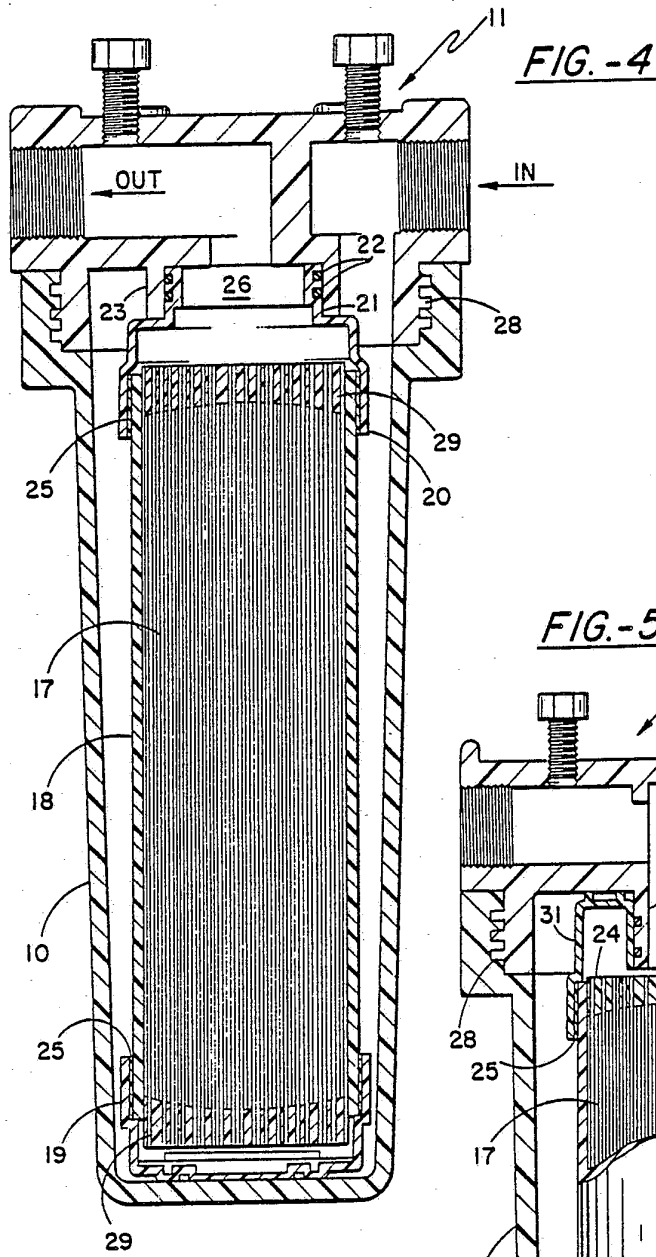

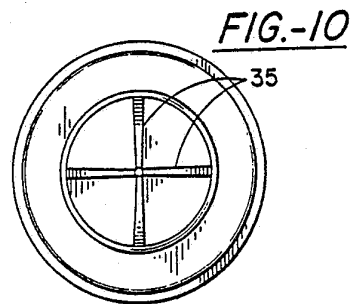
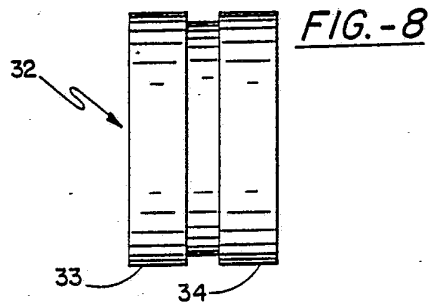
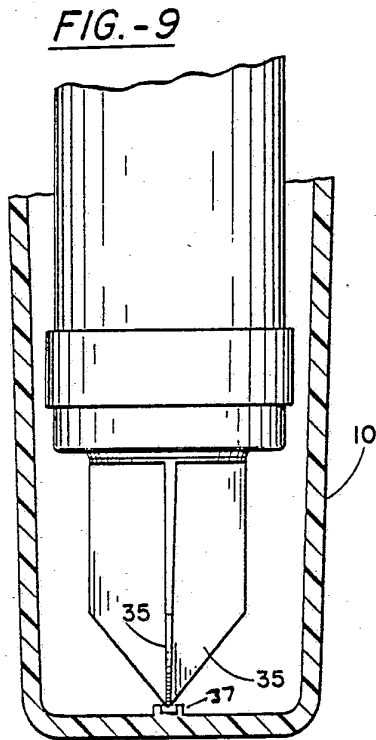
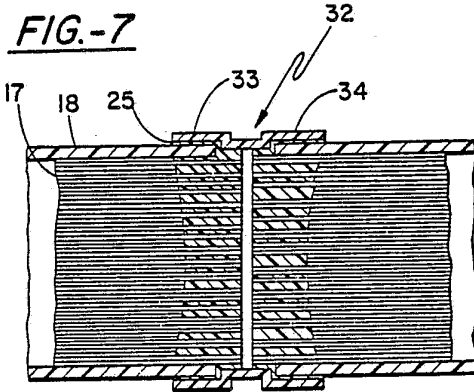
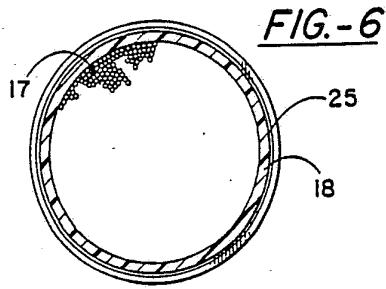
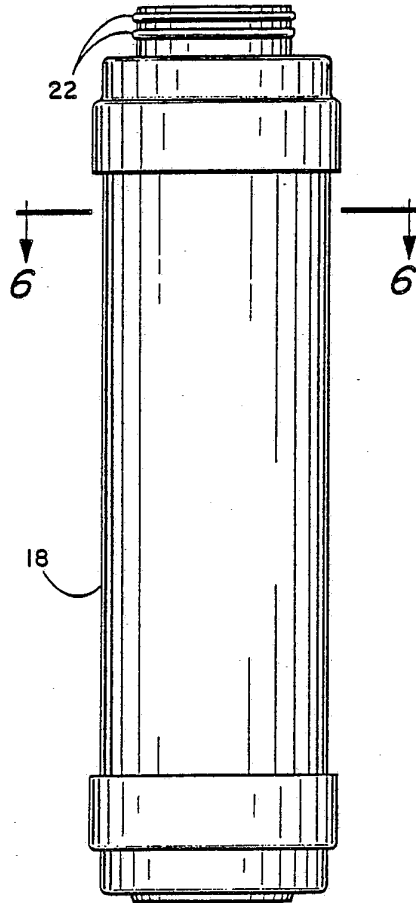
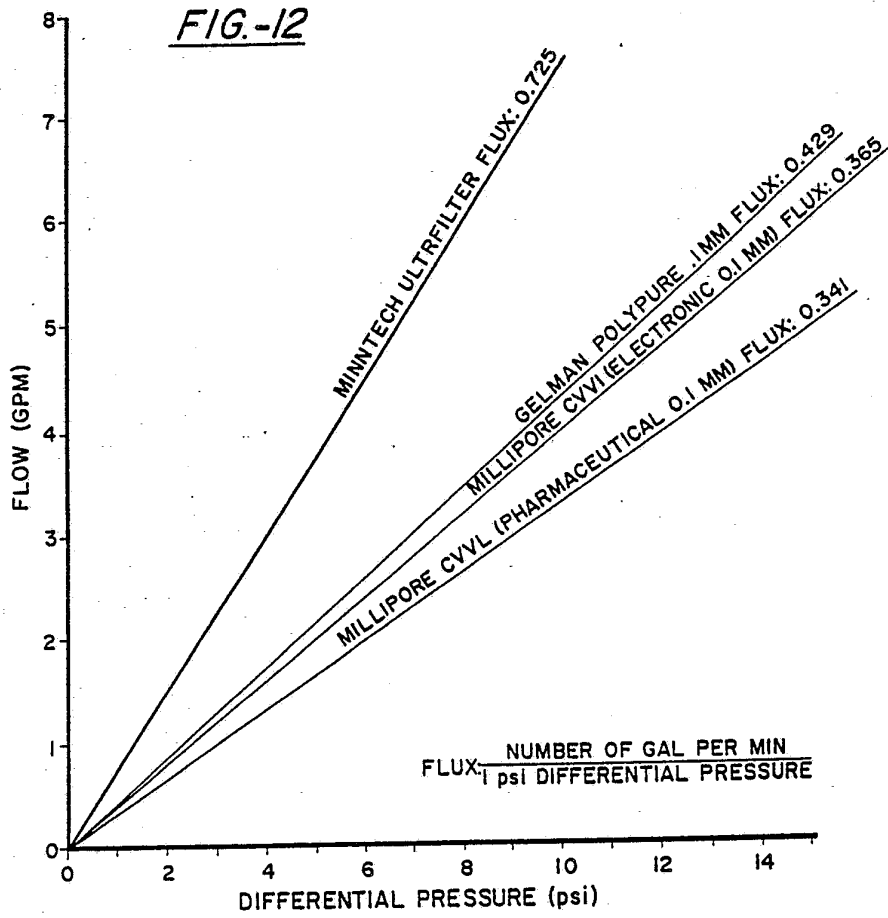

FIG.-11





INTERNATIONAL SEARCH REPORT

International Application No **PCT/US87/01849**

I. CLASSIFICATION OF SUBJECT MATTER (if several classification symbols apply, indicate all) ³		
According to International Patent Classification (IPC) or to both National Classification and IPC		
IPC (4): BOLD 13/01		
U.S. CL. 210/321.87		
II. FIELDS SEARCHED		
Minimum Documentation Searched ⁴		
Classification System ¹	Classification Symbols	
U.S.	210/321.87, 321.88, 321.89 55/158 422/48	
Documentation Searched other than Minimum Documentation to the Extent that such Documents are Included in the Fields Searched ⁵		
III. DOCUMENTS CONSIDERED TO BE RELEVANT ¹⁴		
Category ⁶	Citation of Document, ¹⁶ with indication, where appropriate, of the relevant passages ¹⁷	Relevant to Claim No. ¹⁸
Y	US, A, 4,547,289 (OKANO et al) 15 October 1985 See the entire document	1-14
Y	US, A, 4,594,161 (GOTO) 10 June 1986, See cover 107 and filter 105	1-14
Y	US, A, 4,352,736 (UKAI et al) 05 October 1982, See figures 6 and 7	6, 7
<p>* Special categories of cited documents: ¹⁵</p> <p>"A" document defining the general state of the art which is not considered to be of particular relevance</p> <p>"E" earlier document but published on or after the international filing date</p> <p>"L" document which may throw doubts on priority claim(s) or which is cited to establish the publication date of another citation or other special reason (as specified)</p> <p>"O" document referring to an oral disclosure, use, exhibition or other means</p> <p>"P" document published prior to the international filing date but later than the priority date claimed</p> <p>"T" later document published after the international filing date or priority date and not in conflict with the application but cited to understand the principle or theory underlying the invention</p> <p>"X" document of particular relevance; the claimed invention cannot be considered novel or cannot be considered to involve an inventive step</p> <p>"Y" document of particular relevance; the claimed invention cannot be considered to involve an inventive step when the document is combined with one or more other such documents, such combination being obvious to a person skilled in the art.</p> <p>"&" document member of the same patent family</p>		
IV. CERTIFICATION		
Date of the Actual Completion of the International Search ³	Date of Mailing of this International Search Report ³	
02 November 1987	30 NOV 1987	
International Searching Authority ¹	Signature of Authorized Officer ²⁰	
ISA/US	<i>David R. Sadowski</i> DAVID R. SADOWSKI	