

[54] **IMPLANTABLE ELECTRODES FOR THE STIMULATION OF THE SCIATIC NERVE**

[76] Inventors: **Roger E. Avery**, 145 Rome St., Melville; **James S. Wepsic**, 84 Prince St., Jamaica Plains, both of N.Y.

[22] Filed: **Dec. 14, 1970**

[21] Appl. No.: **97,987**

[52] U.S. Cl. **128/418**

[51] Int. Cl. **A61n 1/04**

[58] Field of Search 128/2.06 E, 2.1 E, 128/404, 411, 410, 418, 419 C, DIG. 4

[56] **References Cited**

UNITED STATES PATENTS

3,650,276	3/1972	Burghelle et al.....	128/418
2,943,628	7/1960	Howell.....	128/418
1,588,182	6/1926	Gibson.....	128/418
3,295,515	1/1967	Kahn.....	128/418
2,047,308	7/1936	Chapman.....	128/418
3,543,761	12/1970	Bradley.....	128/418
3,067,749	12/1962	Walters.....	128/418
1,597,061	8/1926	Cultra.....	128/404
3,279,468	10/1966	Le Vine.....	128/410
3,244,174	4/1966	Wesbey et al.....	128/418

Primary Examiner—William E. Kamm
Attorney—Leonard H. King

[57] **ABSTRACT**

An electrode for the stimulation of the sciatic nerve is disclosed, the electrode being comprised of a pair of physiologically inert plastic strips each of which has a plurality of contact means fixed thereto. The contact or electrode means which preferably are formed of platinum comprise a plurality of buttons positioned on opposite sides the sciatic nerve and are oriented by the surgeon with respect to each other to achieve optimum pain inhibition. When properly placed, the two plastic members are suitably secured to each other. External power means that are electrically coupled to the contact buttons by conductive leads provide selective stimulation of the sciatic nerve in order to relieve pain. The conductive leads for the contact buttons that are not coupled to the source of electrical power are severed.

The aforementioned abstract is neither intended to define the invention of the application which, of course, is measured by the claims, nor is it intended to be limiting as to the scope of the invention in any way.

13 Claims, 9 Drawing Figures

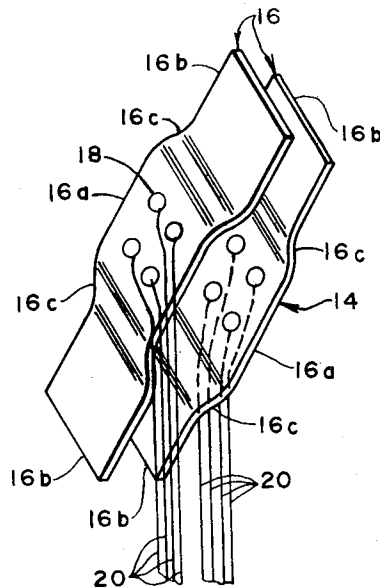

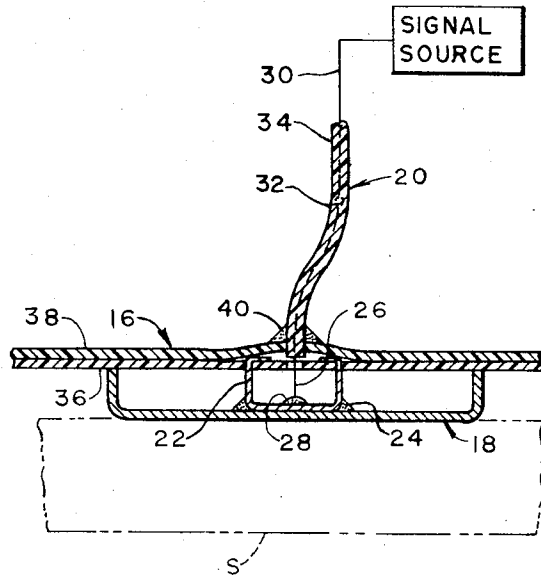
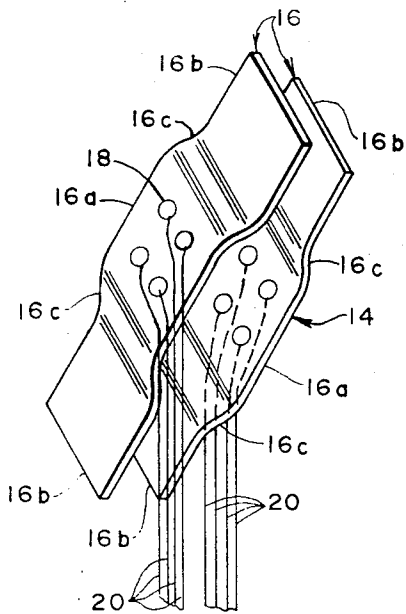
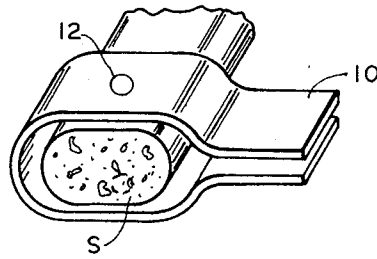
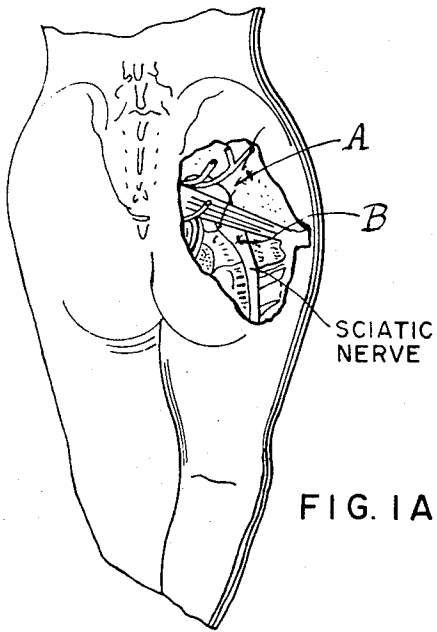

INVENTOR
ROGER E. AVERY
JAMES S. WEPSIC

BY

Leonard H. King
ATTORNEY

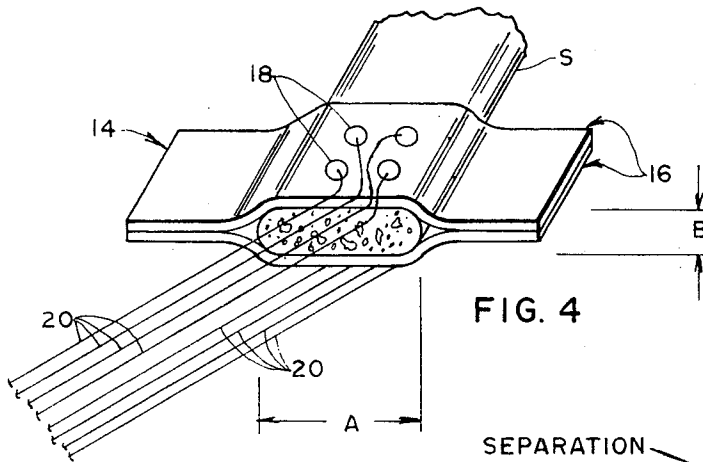

FIG. 4

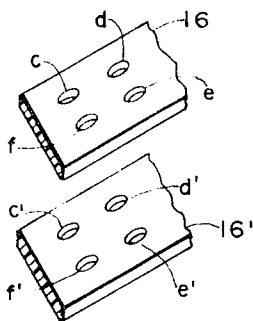

FIG. 7

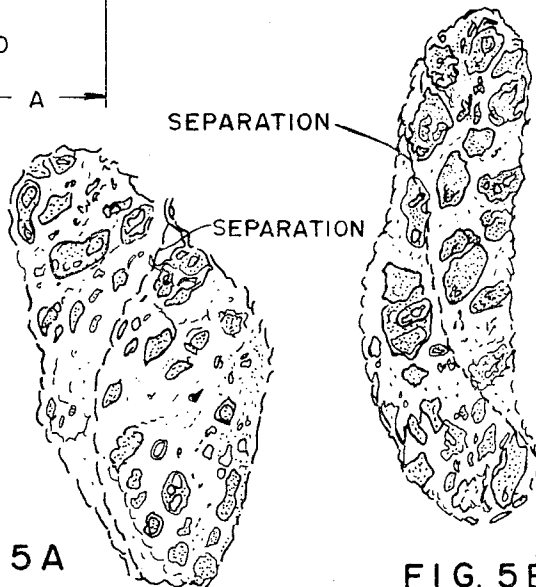

FIG. 5A

FIG. 5B

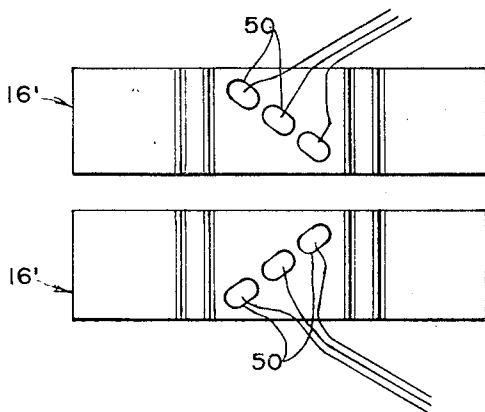

FIG. 6

INVENTOR
ROGER E. AVERY
JAMES S. WEPSIC
BY
Edward H. King
ATTORNEY

IMPLANTABLE ELECTRODES FOR THE STIMULATION OF THE SCIATIC NERVE

This invention relates generally to an implantable electrode for use in the human body and more particularly to an improved device for stimulating the sciatic nerve.

BACKGROUND OF THE INVENTION

There are many different types of therapy that require surgical procedures wherein electrodes are implanted in the body for stimulating a selected nerve. Pain inhibition is an example of one application wherein devices of the type that will be subsequently described are a particularly advantageous therapeutic tool. A source of power electrically coupled to the electrode may also be implanted or an external source of power and a transmitter may be utilized, together with an implanted receiver. Regardless of the techniques that are used, it is absolutely essential that the body be able to tolerate the foreign object for extended periods of time.

The management of chronic, severe pain has historically been an elusive and compromising problem for the physician. One example of such pain is the "phantom pain" in an amputated extremity. Pain of partial nerve injury due to trauma or vascular disease is also difficult to deal with using traditional narcotics or neuro-destructive procedures. Recently, however, researchers have gained significant insight into the physiology of pain. From their observation and from recent developments in the field of neuro-stimulation, the physician now has means for controlling pain by utilizing the body's own natural inhibiting mechanisms. The new devices are beneficial in that they provide non-destructive means for regulating pain without the systematic administration of drugs. Electrical stimulation for the purpose of regulating or inhibiting pain is non-destructive and permits great selectivity in relieving severe pain in the desired region.

One of the problems encountered in developing an electrical stimulator for the sciatic nerve resides in the fact that there are really two nerve bundles in one, both of the bundles being covered by a sheath system. There are also substantial differences in the connective tissue and the relative positions of the two bundles as well as the individual fibers within each bundle. For a surgeon attempting to get at one series of fibers it is virtually impossible to judge, from one person to the next, where to place the point electrodes. Attempts made by the prior art structures to solve this problem were not satisfactory.

The devices used in the past have generally consisted of a flat strip of plastic material in which two contact buttons were imbedded with conductive leads extending from the buttons to the power source. The plastic strip was then wrapped around the sciatic nerve such that the buttons were in opposition to each other with the nerve therebetween. However, with the prior art structure there was very little possibility for the surgeon to reorient the contact buttons so as to change their relative position since the device was made in one piece. Frequently, the buttons in the prior art would be too far to one side or the other.

In the usage of the device comprising the present invention, a curvilinear incision is made through the gluteus maximus over the sciatic notch of the ilium. This

allows stimulation of the sciatic nerve at its most proximate point of exit from the pelvis. It is useful to stimulate proximally to allow inhibition of pain for as much of the leg as is possible. With the muscles and tissues retracted the implant is sutured in place and the leads from the electrode are connected directly to an external signal source to allow direct stimulation of the nerve. Usually the patient can tolerate this arrangement for several days allowing the surgeon to electrically energize different combinations of electrodes to achieve optimum relief in the proper location of the patient's pain. When the most effective electrode sites are determined, the remaining leads connected to the sites not to be stimulated are severed and receiver means are implanted after connection to the leads that have been selected for stimulation.

In its broadest aspect, the present invention comprises two separate sections that are sutured together around the nerve after they are appropriately aligned, with respect to each other. Each of the sections comprises a plurality of platinum contact buttons, each of the buttons having a platinum staple welded thereto. A separate length of platinum wire is also welded to each staple and button combination. Preferably, the contact button is concave with the staple being positioned internally. A stainless steel lead wire is then coupled to the platinum lead wire.

The present invention avoids dissimilar materials adjacent the contact button. The platinum staple is secured to a relatively thin strip of dacron mesh reinforced silicon rubber which is covered with another layer of the same material, the platinum together with the stainless steel lead wire, being encased in a plastic tube. Preferably the leads are color coded so that the surgeon may know the exact position of each electrode. A colored suture thread inside the plastic tube is used for this purpose. It should also be noted that the stainless steel lead wire is remote from the platinum contact button and is insulated therefrom. Further, it is to be understood that the term "plastic" in its present context refers to a medical grade material that is an electrical insulator and which is physiologically inert to body fluids and tissues.

As noted hereinabove, there are provided two of the aforementioned assemblies, one on each side of the sciatic nerve, so that the contact buttons are in opposition to each other. There are provided in the preferred embodiment a total of eight contact buttons and eight leads. As opposed to the prior art structure, the present invention provides that the leads come out of the plastic layers at an angle to the length thereof. This allows the leads to leave the site of implantation in the proper plane of the overlying musculature and to provide a more stable attachment of the electrode to the nerve. In addition, it prevents stress on the electrode-lead interface during exercise of the patient. As will be explained hereinafter in making the implant it is necessary to reach the site of implant through an opening located from a remote point and at an angle to the sciatic nerve.

Accordingly, it is a primary object of the present invention to provide an improved implantable device for stimulating a nerve by means of electricity, whereby pain being sensed by that nerve is inhibited.

Another object of this invention is to provide a device as described above, particularly for use in conjunction with the sciatic nerve, the device being made in

two complimentary halves that are sutured in place during surgery.

A further object of this invention is to provide an improved implantable device for stimulating the sciatic nerve as described above, the device including two halves each having a plurality of electrodes whereby the electrodes in one of the halves may be oriented with respect to the electrodes in the other half.

These and other objects, features and advantages of the invention will, in part, be pointed out with particularity and will, in part, become obvious from the following more detailed description of the invention, taken in conjunction with the accompanying drawings, which forms an integral part thereof.

DESCRIPTION OF THE DRAWING

In the drawing:

FIG. 1A is a pictorial showing of a portion of a human torso showing in phantom the location of sciatic nerve;

FIG. 1B is a perspective, schematic view illustrating a typical prior art structure;

FIG. 2 is an exploded, perspective view of a preferred embodiment of the present invention;

FIG. 3 is a greatly enlarged, sectional elevational view of a typical button contact and plastic strip assembly comprising the present invention;

FIG. 4 is a schematic perspective view showing the relationship of the present invention to a typical sciatic nerve;

FIG. 5A and 5B are cross sectional views showing the difference in fat and asymmetry of two different sciatic nerves taken in the buttock area;

FIG. 6 is a plan view of an alternative embodiment of the present invention; and

FIG. 7 is a schematic view, typical of both embodiments illustrating the improved selectivity of electrode position made possible by the present invention.

DESCRIPTION OF THE PREFERRED EMBODIMENT

In FIG. 1A there is shown a portion of the human body showing the point A at which the curvilinear incision is made and the point B where electrode connection is made to the sciatic nerve at its most proximate point of exit from the pelvis. The surgeon performs the actual implant through a "tunnel" through retracted muscle layers, about five inches long. This tunnel is oriented at any acute angle making implantation with the prior art structures used for connection to peripheral nerves. A typical prior device is shown schematically and in perspective in FIG. 1B.

The prior art device is comprised of a thin plastic strip 10 that is adapted to be implanted in a human body. A pair of electrodes 12 are imbedded in the plastic strip 10 such that they, the electrodes 12, will be positioned in opposition to each other when the device is installed, and adjacent the sciatic nerve designated by the reference character S. A difficulty encountered with this form of prior art device is that orientation of the electrodes 12 with respect to each other and to specific fibers in the sciatic nerve was virtually impossible because of the one-piece form of construction. That is, it was necessary to wrap the one-piece device about the nerve. At best, the surgeon could only compromise with the optimum position of the device. As a result, the relief from pain was not as complete as it could be.

There is shown in FIG. 2 and FIG. 3, the preferred embodiment of the present invention. The implant 14 comprising the present invention consists of two spacedly opposed strips 16 made of a relatively thin, inert plastic material such as dacron mesh reinforced with silicon rubber. A plurality of contact buttons or electrodes 18 are imbedded in each of the strips 16, in a manner to be described more fully hereinafter, and lead wires, generally designated by the reference character 20, are electrically coupled to the contact buttons. The leads 20 are positioned at an angle to the length of the strips 16 and are color coded by any suitable means such as colored suture thread or lumens.

Each of the strips 16 is preferably molded with a central section 16a and two laterally positioned end sections 16b, the central section 16a being in a plane different from the end sections 16b so that when the two strips 16 are positioned such as shown in FIG. 2, there will be a central recess for the nerve, the recess being defined by the spacedly opposed central sections 16a. The degree of molded-in curvature will depend upon the thickness of the plastic and the degree to which it can be made to envelope a portion of the nerve. While the various sections have been shown as being relatively flat and joined by angular portions 16c it should be understood that the various sections may also be gentle curves.

Turning now to FIG. 3, the construction of a typical strip 16 and the mounting of an electrode button 18 thereon will be described. A staple 22 is welded at 24 to the inside surface of the cup-shaped electrode button 18. A platinum lead wire 26 is welded to the staple 22 as shown by the reference character 28. A stainless steel lead wire 30 is then secured to the platinum lead wire 26 at junction 32. A length of plastic 34, preferably medical grade silicon or the like, encapsulates the combined lead wires 26 and 30.

The legs of the staple 22 are crimped over a first layer of plastic 36 which is the dacron mesh reinforced with silicon rubber mentioned above, and a second layer 38 made of the same plastic material, is adhesively secured to the layer 36. Sealing means 40 are positioned about the length of plastic 34 where that member passes through the layer 38. As shown in FIG. 3, the outer surface of the electrode button 18 makes a "kissing" contact with the sciatic nerve that is labeled S.

The difficulties encountered in installing a neurostimulator for the sciatic nerve will be more fully appreciated by reference to FIGS. 4, 5A and 5B. As shown particularly in FIGS. 5A and 5B, there are substantial differences in the cross section of the sciatic nerve, for example as taken in the buttock area. There are differences as to the connective tissues surrounding the nerve as well as the asymmetry of the nerve. Accordingly, it was very difficult for the surgeon to select the most effective location for opposed electrodes. With the prior art electrodes the surgeon had very little mechanical leeway in locating the electrode contact points. By use of the present invention, the surgeon may now position the two strips 16 on opposite sides of the sciatic nerve and then move them about relative to each other. It should be noted that eight leads 20 are shown. When the surgeon has determined the two or more contacts that will provide a maximum of relief from pain, the remaining leads may either be severed or connected to a steerable system such as a transmitter with a switching circuit. When the optimum position of

the contacts has been established by the temporary expedient described hereinabove and the unused leads have been severed, the device together with receiver means may be sutured in place. When using the steerable system, the leads are brought out through the skin for connection to a suitable source of electrical energy.

Average dimensions *a* and *b* have been established by study of cadavers at 12.5 millimeters and 5.25 millimeters respectively, for the sciatic nerve in the area of the buttocks. At mid-thigh, the same dimensions *a* and *b*, on an average, are 11.5 millimeters and 4.5 millimeters respectively. Thus, it may be seen that there is a wide deviation from patient to patient, and without means for orienting the opposed electrodes with respect to each other, the problems encountered by the surgeon for providing maximum relief from pain are greatly enlarged.

An alternative embodiment of the present invention is shown in FIG. 6. Instead of aligning the contact or electrode buttons 18 as previously shown in FIG. 2, electrode buttons 50 are positioned along a line that is at an angle with respect to the longitudinal axis of each strip 16'. All of the components of the invention remain the same as described hereinabove. The arrangement as shown in FIG. 6 provides increased selectivity for the surgeon when he moves one of the strips 16' in relation to the other strip 16'.

FIG. 7 is used to show the mathematically possible combinations of electrode pairs that are available to the surgeon. Electrodes *c*, *d*, *e* and *f* are on one plastic strip 16 and opposed electrodes *c'*, *d'*, *e'* and *f'* are on the other strip 16'. Thus there are 32 possible combinations of single pairs of electrodes and if pairs are taken in combination a much greater number of possibilities exists, whereas in the prior art structure shown in FIG. 1, there is only one pair of electrodes available. Six further combinations of electrode pairs are available if both electrodes that are ultimately connected to the receiver means are on the same plastic strip. This last mentioned arrangement is a distinct possibility depending on the nerve fiber to be stimulated and/or the relationship of the surrounding tissue.

While a specific number of contact buttons or electrodes have been shown for each of the two embodiments, it should be clearly understood that the invention is not so limited. Three and four contacts have been illustrated merely for purposes of convenience. Further, while the contacts or electrode buttons 18 have been shown to be rectangular in area, with rounded corners, it should also be understood that other shapes such as oval, ellipses, etc., may be employed within the scope of this invention.

There has been disclosed heretofore the best embodiment of the invention presently contemplated. However, it is to be understood that various changes and modifications may be made by those skilled in the art without departing from the spirit of the invention.

What we claim as new and desire to secure by Letters Patent is:

1. A device implantable within a living body for the electrical stimulation of the sciatic nerve, said device comprising the combination of:

- a. a first and second relatively thin strips of flexible, electrically insulating material that is inert to body fluids and tissues, each of said strips being defined by a pair of longitudinally spaced end sections and a central section therebetween, said central section

being in a plane different from at least one of said end sections, said respective end sections of said first and said second strips, in use, being secured to each other and said opposed central sections defining a recess therebetween having an axis that is substantially perpendicular to the longitudinal axis of said strips, said recess being adapted to accommodate the sciatic nerve therein;

- b. a plurality of substantially flat, button-like electrically conductive electrode means secured to said central section of each of said strips in said recess defined by the combination of said opposed central sections whereby at least one of said electrode means of each of said strips is adapted to directly contact the sciatic nerve when said device is implanted; and

- c. a plurality of conductive lead means secured to said central section of each of said strips, said lead means being electrically and physically coupled to said electrode means.

2. The device in accordance with claim 1 wherein each said lead means is comprised of a platinum section secured to said electrode means and a stainless steel section secured to said platinum section.

3. The device in accordance with claim 1 wherein said electrode means are each comprised of a cup-shaped member and means for securing said cup-shaped member to said strip.

4. The device in accordance with claim 3 wherein said means for securing said cup-shaped member to said strip comprises a staple welded to said cup, said staple being crimped to said strip of insulating material.

5. The device in accordance with claim 4 wherein each said strip comprises a first layer to which said staple is crimped and a second layer sealingly covering said first layer and the legs of said staple, said second layer being remote from said electrode means, said lead means extending through said first and second layers for making electrical contact with said staple.

6. The device in accordance with claim 5 wherein said lead means are encapsulated in an electrically insulating material that is inert to body fluids and tissues, said encapsulating means extending through at least said layer that is remote from said electrode means.

7. The device in accordance with claim 6 further including sealing means positioned about said encapsulating material in the area at which said encapsulating material passes through said remote layer.

8. The device in accordance with claim 1 wherein said electrode means are rectangular in shape.

9. The device in accordance with claim 8 wherein said electrode means are oriented with the longer dimension thereof at an angle with respect to the length dimension of said strips.

10. The device in accordance with claim 1 wherein said strips are molded with the end sections thereof in a common plane and the central portion thereof intermediate said end section being in a different plane.

11. The device in accordance with claim 1 wherein said lead means are encapsulated in a flexible, electrically insulated material that is inert to body fluids and tissues.

12. The device in accordance with claim 1 further including color coding means for said lead means.

13. The device in accordance with claim 1 wherein said lead means leave said strip at an angle with respect to the length dimension thereof.