

(19) World Intellectual Property Organization
International Bureau



(43) International Publication Date
7 June 2001 (07.06.2001)

PCT

(10) International Publication Number
WO 01/40933 A2

(51) International Patent Classification⁷: G06F 9/00

(21) International Application Number: PCT/US00/33034

(22) International Filing Date: 6 December 2000 (06.12.2000)

(25) Filing Language: English

(26) Publication Language: English

(30) Priority Data:
60/169,145 6 December 1999 (06.12.1999) US

(71) Applicant: AXIOMATIC DESIGN SOFTWARE, INC.
[US/US]; 221 North Beacon Street, Boston, MA 02135-1943 (US).

(72) Inventor: DO, Sung-Hee; Unit 605C, 40 Kings Way, Waltham, MA 02451 (US).

(74) Agent: RUSSAVAGE, Edward, J.; Wolf, Greenfield & Sacks, P.C., 600 Atlantic Avenue, Boston, MA 02210 (US).

(81) Designated States (*national*): AE, AG, AL, AM, AT, AU, AZ, BA, BB, BG, BR, BY, BZ, CA, CH, CN, CR, CU, CZ, DE, DK, DM, DZ, EE, ES, FI, GB, GD, GE, GH, GM, HR, HU, ID, IL, IN, IS, JP, KE, KG, KP, KR, KZ, LC, LK, LR, LS, LT, LU, LV, MA, MD, MG, MK, MN, MW, MX, MZ, NO, NZ, PL, PT, RO, RU, SD, SE, SG, SI, SK, SL, TJ, TM, TR, TT, TZ, UA, UG, UZ, VN, YU, ZA, ZW.

(84) Designated States (*regional*): ARIPO patent (GH, GM, KE, LS, MW, MZ, SD, SL, SZ, TZ, UG, ZW), Eurasian patent (AM, AZ, BY, KG, KZ, MD, RU, TJ, TM), European patent (AT, BE, CH, CY, DE, DK, ES, FI, FR, GB, GR, IE, IT, LU, MC, NL, PT, SE, TR), OAPI patent (BF, BJ, CF, CG, CI, CM, GA, GN, GW, ML, MR, NE, SN, TD, TG).

Published:
— Without international search report and to be republished upon receipt of that report.

For two-letter codes and other abbreviations, refer to the "Guidance Notes on Codes and Abbreviations" appearing at the beginning of each regular issue of the PCT Gazette.

(54) Title: METHOD AND APPARATUS FOR PRODUCING SOFTWARE

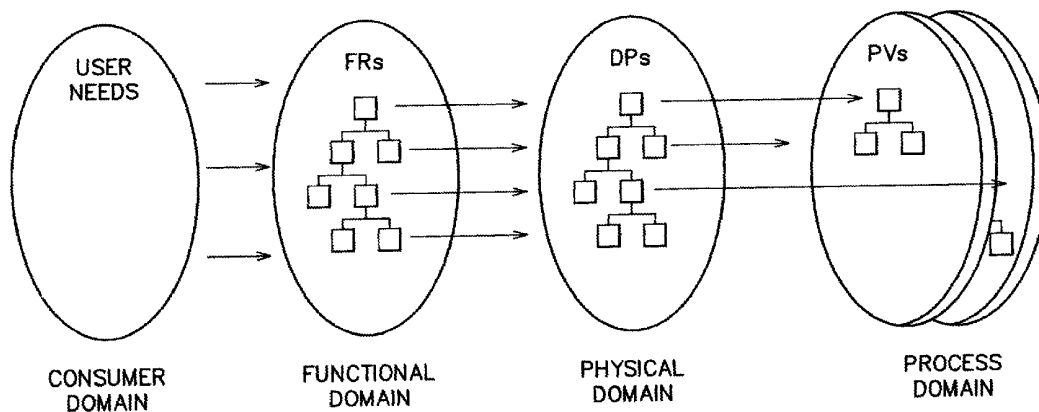

(57) Abstract: A system and method for producing software code is provided. In particular, a new software design methodology is provided that is based on axiomatic design theory. In one aspect, axiomatic design theory is adapted for use in designing object-oriented software programs. This methodology overcomes the shortcomings of various software design strategies including extensive software development and debugging time and the need for extensive maintenance. Because traditional software design strategies are not heuristic and do not provide basic principles for the development of good software systems, bad design habits produce poor quality software. A design framework using axiomatic design for software overcomes many of the shortcomings of current software design techniques: high maintenance costs, limited reusability, the need for extensive debugging and testing, poor documentation, and limited extensibility of the software, all of which result in high development cost of software.



WO 01/40933 A2

METHOD AND APPARATUS FOR PRODUCING SOFTWARE

Related Application

5 This application claims the benefit under Title 35, U.S.C. §119(e) of co-pending U.S. Provisional Application Serial No. 60/169,145, filed December 6, 1999, entitled "Method and Apparatus for Producing Software" by Sung-Hee Do, the contents of which are incorporated herein by reference.

Field of the Invention

10 The invention relates generally to software systems, and more specifically to a system and method for designing and producing software code.

Background

15 There are many different methods for producing software. Generally, software is designed and produced manually by programmers. Programmers design and program the software architecture in some type of programming language such as C, C++, Java, or the like. There are problems with manual methods of software design, in that the quality of manual methods generates flawed code because of human error. Further,
20 software design is not optimized because software design processes are performed by humans using non-optimizing processes. For example, individuals may develop individual modules of code that perform redundant functions, exchange unnecessary information, or depend on other modules in an inefficient manner. Further, when these
25 modules are modified, the software design needs to be retested, as there is typically relationships between modules that have been modified and other modules that access them. Also, individuals may develop certain code modules that cannot be reused in later projects.

 Also, the design and production of quality software is a typically a long-term process involving design, coding and testing periods. Because software production
30 cycles must decrease to meet shorter design schedules, it would be beneficial to have a software system and method that produces code in an error-free, efficient, and expedient manner. Also, it would be beneficial to be able to reuse software code between projects. In summary, existing methods for producing software are non-optimal, resulting in

increased cost of development, high maintenance costs, limited reusability, the need for extensive debugging and testing, and poor documentation.

Summary

5 A system and method is provided which allows a programmer to design and generate programs in an error-free and expedient manner, and allows software reuse. According to one embodiment of the invention, a system and method is provided which allows a programmer to apply axiomatic design principles to design and generate software. More specifically, the system and method allows a programmer to define a set
10 of functional requirements (FRs) that describe what the software is to achieve. The system allows the programmer to generate software based on design parameters (DPs) that describe the software system such as inputs, hardware, ASICs (application specific integrated circuits), software, or other aspects of the software system that meet the functional requirements.

15 A relation between FRs and DPs can be described in a mathematical manner by a design matrix. An uncoupled or decoupled design matrix may describe a system which has no feedback loops, and therefore the software system is more easily changed, because a change in one portion of the software does not have an unknown affect on another portion of the software through feedback. Software code may be automatically
20 generated from the axiomatic design. Because the software system may be described and generated in a systematic manner, software quality is improved. Also, the time for producing the software is decreased because the quality is high, and there is less direct coding by the programmer.

 These and other advantages are provided by:

25 A digital information product comprising a computer-readable medium, and stored on the computer-readable medium, computer program instructions defining a software system that produces software code based on a set of functional requirements provided by a programmer. According to one embodiment of the invention, the computer program instructions, when executed, allow the programmer to define a design
30 matrix describing a relation between the set of functional requirements and the design parameters. According to another embodiment of the invention, the computer program instructions, when executed, allow a programmer to manipulate the design matrix into lower triangular form. According to another embodiment of the invention, the computer

program instructions, when executed, allow a programmer to determine an decoupled design matrix. According to another embodiment of the invention, the computer program instructions, when executed, allow a programmer to determine an uncoupled design matrix.

5 According to another embodiment of the invention, the method comprises defining a design matrix describing a relation between functional requirements of the software system and design parameters; and generating software code based on the design matrix. According to another embodiment of the invention, the method further comprises a step of constructing functions using diagonal elements of the design matrix.

10 According to another embodiment of the invention, the method further comprises a step of defining a flow description that describes a flow of the software system. According to another embodiment of the invention, the method further comprises a step of defining a software module corresponding to at least one functional requirement. According to another embodiment of the invention, the software module is defined based upon the
15 flow description.

 According to another embodiment of the invention, the method further comprises a step of defining a plurality of software modules, each of which corresponds to a respective functional requirement. According to another embodiment of the invention, the method further comprises relating the plurality of software modules by junctions.

20 According to another embodiment of the invention, the method further comprises a step of combining the plurality of software modules according to their junctions. According to another embodiment of the invention, at least one of the junctions is selected from a group including a summation junction, a control junction, and a feedback junction.

 According to another aspect of the invention, a method for producing software is
25 provided comprising defining a design matrix describing a relation between functional requirements of the software system and design parameters; and generating software code based on the design matrix. According to another embodiment of the invention, the step of defining includes determining a design matrix having a lower triangular form.

 According to another embodiment of the invention, the step of defining includes
30 determining an uncoupled design matrix. According to another embodiment of the invention, the step of defining includes determining a design matrix having a diagonal form. According to another embodiment of the invention, the step of defining includes determining a decoupled design matrix. According to another embodiment of the

invention, the step of generating comprises: generating a plurality of models; and outputting the models to a code generator. According to another embodiment of the invention, the step of generating comprises generating at least one diagram describing an object-oriented object structure. According to another embodiment of the invention, the at least one diagram is in a Unified Modeling Language (UML) format.

According to another embodiment of the invention, the at least one diagram includes at least one of a group of diagrams comprising a use-case diagram; and an entity-relation diagram. According to another embodiment of the invention, the code generated includes object-oriented entities. According to another embodiment of the invention, the method further comprises a step of defining an object-oriented class using at least one functional requirement. According to another embodiment of the invention, the method further comprises a step of defining a child of the object-oriented class using at least one functional requirement. According to another embodiment of the invention, the method further comprises a step of defining a grandchild of the object-oriented class using at least one functional requirement. According to another embodiment of the invention, the grandchild of the object-oriented class defines behavior of the class. According to another embodiment of the invention, at least one functional requirement represents at least one object-oriented software entity. According to another embodiment of the invention, the generated software code is source code.

According to another aspect of the invention, a method for designing software is provided which involves object-oriented software objects, the method comprising defining a design matrix describing a relation between a plurality of functional requirements of the software system and design parameters; representing at least one object-oriented object by at least one of the functional requirements; representing data used by the at least one object-oriented software object by at least one of the design parameters; and representing a method of the at least one object-oriented software object by a product of a portion of the design matrix and the at least one design parameter. According to another embodiment of the invention, the method further comprises defining a plurality of functional requirements and constraints of the software system. According to another embodiment of the invention, the method further comprises a step of decomposing at least one functional requirement into leaf elements. According to another embodiment of the invention, the method further comprises a step of decomposing at least one design parameter into leaf elements. According to another

embodiment of the invention, the method further comprises a step of decomposing at least one process variable into leaf elements.

According to another aspect of the invention, a method for designing software is provided comprising defining a software system by defining a design matrix describing a relation between functional requirements of the software system and design parameters implementing the software system; defining at least one object-oriented object; and defining at least one method that may be defined on the at least one object, wherein the at least one object-oriented object and the at least one method are related to the design matrix. According to another embodiment of the invention, the method further comprises defining an object class of the at least one object-oriented object that represents a first level of functional requirements of the design matrix. According to another embodiment of the invention, the method further comprises defining an instance of the object class represented by a second level of functional requirements of the design matrix. According to another embodiment of the invention, the method further comprises defining behavior of the object class as a third level of functional requirements of the design matrix. According to another embodiment of the invention, the first, second, and third levels are successive levels of a functional requirement hierarchy. According to another embodiment of the invention, the method further comprises mapping the functional requirements into a physical implementation domain by defining design parameters.

According to another embodiment of the invention, the method further comprises a step of construction functions using diagonal elements of the design matrix. According to another embodiment of the invention, the step of defining a software system includes determining whether the design matrix is uncoupled. According to another embodiment of the invention, the method further comprises generating a plurality of models and outputting the models to a code generator. According to another embodiment of the invention, the step of generating comprises generating at least one diagram describing an object-oriented system structure. According to another embodiment of the invention, the at least one diagram includes at least one of a group of diagrams including a use-case diagram; and an entity-relation diagram. According to another embodiment of the invention, the at least one diagram is in a Unified Modeling Language format.

According to another aspect of the invention, a database format is provided for designing a software system comprising a software design specification, wherein the

design specification defines a design matrix describing a relation between a plurality of functional requirements of the software system and design parameters, wherein the design specification represents at least one software object by at least one of the functional requirements, and wherein the design specification represents data used by the at least one software object by at least one of the design parameters; and software code produced by the design specifications. According to another embodiment of the invention, the software design specification further comprises a design identification identifying the software code. According to another embodiment of the invention, the software design specification further comprises a detailed design description including the design matrix, functional requirements and design parameters. According to another embodiment of the invention, the software design specification further comprises a detailed design description including the design matrix, functional requirements and design parameters. According to another embodiment of the invention, the software design specification further comprises a design identification identifying the software code. According to another embodiment of the invention, the design parameters are arranged in a plurality of levels, and wherein each of the plurality of levels can be referenced by another software system. According to another embodiment of the invention, the database format for designing a software system is used in a software production system, and a user operating the software production system is capable of creating software comprising one or more elements of the software system. According to another embodiment of the invention, the software production system further comprises a user interface and a database implementing the database format, and the software production system is capable of searching through the database to obtain one or more elements of the software system to create a new software system. According to another embodiment of the invention, a new element of the new software system interfaces with one or more elements of the software system, and the software production system is operable to verify that the interface is operable. According to another embodiment of the invention, the software production system is configured to verify a consistency of design of the new software system.

According to another embodiment of the invention, the software production system is configured to search design parameter information, including at least one of description information, keywords associated with the software system, categories in which the software system is assigned, and comments. According to another

embodiment of the invention, the software code is in executable form. According to another embodiment of the invention, the software code is source code. According to another embodiment of the invention, the software production system is configured to verify a consistency of design of the new software system by checking a consistency
5 between a first level of design implementing a design parameter from the database and a second level of design of the new software system. According to another embodiment of the invention, the second level of design is a child of the first level of design. According to another embodiment of the invention, a new element of the new software system interfaces with one or more elements of the software system, and the software production
10 system is operable to verify that the interface is operable.

According to another aspect of the invention, a database format for designing a software system is provided comprising design identification information identifying information describing the software system; detailed design description information describing the structure and operating qualities of the software system; and software
15 code information associated with the software system. According to another embodiment of the invention, the detailed design description defines a design matrix describing a relation between a plurality of functional requirements of the software system and design parameters, wherein the design specification represents at least one software object by at least one of the functional requirements, and wherein the detailed
20 design description represents data used by the at least one software object by at least one of the design parameters. According to another embodiment of the invention, the software code information comprises source code.

According to another aspect of the invention, a method is provided for generating software code associated with a software system, the method comprising defining a
25 design matrix describing a relation between functional requirements of the software system and design parameters; and generating software code based on the design matrix. According to another embodiment of the invention, the method further comprises defining a plurality of functional requirements and constraints of the software system. According to another embodiment of the invention, the method further comprises a step
30 of decomposing at least one functional requirement into leaf elements. According to another embodiment of the invention, the method further comprises a step of decomposing at least one design parameter into leaf elements. According to another embodiment of the invention, the method further comprises a step of decomposing at

least one process variable into leaf elements. According to another embodiment of the invention, the software code is written in a modeling code language. According to another embodiment of the invention, the software code is executable by a computer system. According to another embodiment of the invention, the modeling code language is the Unified Modeling Language (UML). According to another embodiment of the invention, the software code describes at least one diagram of a group comprising a class diagram; an interaction diagram; a collaboration diagram; a sequence diagram; a state diagram; and an activity diagram.

According to another embodiment of the invention, the method further comprises a step of relating the design matrix to at least one element of the at least one diagram. According to another embodiment of the invention, the system creates a use-case diagram based upon the design matrix. According to another embodiment of the invention, the method further comprises defining a plurality of customer needs, the plurality of needs being arranged in a hierarchical tree having levels, and wherein at least one of the levels relates to a layer of a use-case diagram. According to another embodiment of the invention, the use-case diagram includes a relation layer, a use case layer and an actor layer. According to another embodiment of the invention, the actor layer represents one or more actors.

According to another embodiment of the invention, the use case layer describes customer needs that are attributed to the actor. According to another embodiment of the invention, the relation layer describes a relationship between customer needs in customer needs in the use case layer. According to another embodiment of the invention, the relationship is a semantic connection among model elements. According to another embodiment of the invention, the software code includes a model file which describes the modeling code. According to another embodiment of the invention, the model file is suitable for use as an input file for use by a software production system to create a software system.

According to another aspect of the invention, a computer-readable medium is provided which is encoded with a program that, when executed on a computer system, performs a method for rendering an interface through which a user may interact, the method comprising steps of displaying a software design interface, wherein the interface displays a set of functional requirements upon which a software design is based, and wherein the interface displays a design matrix describing a relation between the set of

functional requirements and design parameters implementing the software design. According to another embodiment of the invention, the computer system performs a step of indicating, in association with the displayed design matrix, whether the software design specified by the design matrix is at least one of a group including a decoupled, uncoupled or coupled design.

According to another embodiment of the invention, the design matrix represents a coupled design, and wherein the computer system performs a step of indicating, in association with the displayed design matrix, whether a design parameter associated with the design matrix is coupled. According to another embodiment of the invention, the computer system performs a step of indicating, for the design parameter associated with the design matrix, an alternate rearrangement of the design parameter wherein the design parameter, if rearranged, is uncoupled or decoupled. According to another embodiment of the invention, the computer system performs a step of indicating, for the design matrix, an accuracy of the software design with respect to an optimum design.

According to another embodiment of the invention, the computer system performs a step of indicating, for the design matrix, a range of acceptable inputs over which the design matrix operates. According to another embodiment of the invention, the computer system performs a step of arranging and displaying the functional requirements and design parameters to the user in a hierarchical manner. According to another embodiment of the invention, the computer system performs a step of displaying the functional requirements and design parameters in a hierarchical tree having a plurality of levels. According to another embodiment of the invention, the computer system performs a step of indicating a robustness of the software. According to another embodiment of the invention, the computer system performs a further step of creating, based upon an arrangement of the design parameters, a Gantt chart describing production dependencies of the software design.

Further features and advantages of the present invention as well as the structure and operation of various embodiments of the present invention are described in detail below with reference to the accompanying drawings. In the drawings, like reference numerals indicate like or functionally similar elements. Additionally, the left-most one or two digits of a reference numeral identifies the drawing in which the reference numeral first appears. All references cited herein are expressly incorporated by reference.

Brief Description of the Drawings

This invention is pointed out with particularity in the appended claims. The above and further advantages of this invention may be better understood by referring to the following description when taken in conjunction with the accompanying drawings in which similar reference numbers indicate the same or similar elements.

In the drawings,

Figure 1 is a block diagram illustrating concepts of domain, mapping and spaces;

Figure 2 is a block diagram showing different types of design matrices;

10 Figure 3 is a block diagram showing different types of control junctions;

Figure 4 is a block diagram showing different types of system architecture;

Figure 5 is a block diagram showing an axiomatic design process for designing object-oriented software according to one embodiment of the invention;

15 Figure 6 is a block diagram showing an object representation in terms of functional requirements according to one embodiment of the invention;

Figure 7 is a block diagram illustrating Rumbaugh's object model notation;

Figure 8 is a block diagram of an example of an object-oriented diagram according to one embodiment of the invention;

20 Figure 9 is a block diagram of an example object class and instance according to one embodiment of the invention;

Figure 10 is a block diagram showing transitions between functional and physical domains according to one embodiment of the invention;

Figure 11 is a block diagram showing a Structured Analysis and Design Technique (SADT) diagram;

25 Figure 12 is a block diagram of an example design matrix according to one embodiment of the invention;

Figure 13 is a block diagram showing a design matrix implementation and consistency check according to one embodiment of the invention;

30 Figure 14 is a block diagram showing an example object-oriented technique (OOT) diagram according to one embodiment of the invention;

Figure 15 is a block diagram showing a relation between a design matrix and an object-oriented class diagram according to one embodiment of the invention;

Figure 16 is a block diagram showing more detailed relations between a design matrix and an object-oriented class diagram according to one embodiment of the invention;

Figure 17 is a block diagram for the design matrix shown in Figure 16;

5 Figure 18 is a block diagram of a module-junction diagram according to one embodiment of the invention;

Figure 19 is a block diagram of an exemplary environment used for database design according to one embodiment of the invention;

10 Figure 20 is a block diagram of an Entity-Relation (ER) diagram according to one embodiment of the invention;

Figure 21 is a block diagram showing a search for design parameters according to one embodiment of the invention;

Figure 22 is a customer needs diagram according to one embodiment of the invention;

15 Figure 23 is a use case diagram associated with the customer needs diagram of Figure 22;

Figure 24 is an example use case diagram according to one embodiment of the invention;

20 Figure 25 is a block diagram of an example design hierarchy according to one embodiment of the invention;

Figure 26 is a block diagram of an example design matrix according to one embodiment of the invention;

Figure 27 is a block diagram of an example class representation according to one embodiment of the invention;

25 Figure 28 is a block diagram of example classes according to one embodiment of the invention;

Figure 29 is a block diagram of detailed method definitions associated with the example classes of Figure 28;

30 Figure 30 is a block diagram of class definitions according to one embodiment of the invention;

Figure 31 is a chart showing relation definitions according to one embodiment of the invention;

Figure 32 is a class diagram according to one embodiment of the invention;

Figure 33 is a chart showing an interaction definition according to one embodiment of the invention;

Figure 34 shows an example collaboration diagram according to one embodiment of the invention;

5 Figure 35 is a sequence diagram according to one embodiment of the invention;

Figure 36 is a block diagram of a system architecture flow according to one embodiment of the invention;

Figure 37 is an activity diagram associated with the example according to one embodiment of the invention;

10 Figure 38 is a block diagram of an alternative system architecture having different components;

Figure 39 shows an example generated UML script according to one embodiment of the invention;

15 Figure 40 is an example functional requirements (FR) table according to one embodiment of the invention;

Figure 41 is an example DP/VARIABLE table according to one embodiment of the invention;

Figure 42 is an example DM/OPERATION table according to one embodiment of the invention;

20 Figure 43 is a block diagram of a standard code skeleton according to one embodiment of the invention;

Figure 44 is a block diagram of an example code skeleton produced according to one embodiment of the invention;

25 Figures 45A-B shows tables mapping functional requirements (FR) to design parameters (DP);

Figures 46A-B are tables showing FRs mapped to multiple alternative DPs;

Figures 47A-B show tables relationships between parent FR/DP information and child FR/DP;

30 Figures 48A-B show a parent numbering structure according to one embodiment of the invention;

Figures 49A-B show tables mapping FRs and constraints according to one embodiment of the invention;

Figure 50 shows a method for mapping CNs and FRs using tables and a tree display;

Figure 51 is a block diagram showing an interface relating actual restraints to a design according to one embodiment of the invention;

5 Figures 52A-C show alternative user interfaces according to one embodiment of the invention;

Figure 53 shows an example nested design matrix table according to one embodiment of the invention;

10 Figures 54A-C show alternative user interfaces according to one embodiment of the invention;

Figures 55A-B show alternative user interfaces indicating activity groups related to design according to one embodiment of the invention;

Figure 56 shows an alternative user interface according to one embodiment of the invention;

15 Figure 57 shows one alternative embodiment of a user interface;

Figure 58 shows an alternative DP toggle button within an FR/DP or DP/PV handling window;

Figure 59 shows a user interface including control buttons used to populate a design matrix according to one embodiment of the invention;

20 Figure 60 shows a table showing how menus, tabs, and buttons are controlled by a road map;

Figure 61 shows an alternative user interface according to one embodiment of the invention;

25 Figure 62 shows a user interface that automatically displays a resized design matrix based on the number of FRs and DPs;

Figures 63A-B show alternative user interface according to one embodiment of the invention;

30 Figures 64A-B show alternative user interfaces that allow one step navigation between adjacent hierarchy levels of a design according to one embodiment of the invention;

Figure 65 shows an adjustment of options based on user experience level according to one embodiment of the invention;

Figure 66 shows a user interface through which a user may adjust numbering scheme of the design according to one embodiment of the invention;

Figure 67 shows an alternative user interface that allows users to adjust elements of a design matrix more precisely;

5 Figure 68 shows an example user interface used to adjust color-coding for legends;

Figure 69 shows an alternative user interface which indicates a size of the design;

Figure 70 shows an example of a live question list according to one embodiment of the invention;

10 Figure 71 shows a live to do list according to one embodiment of the invention;

Figure 72 shows one alternative user interface according to one embodiment of the invention;

Figure 73 shows a user interface displaying child lists according to one embodiment of the invention;

15 Figure 74 shows a user interface displaying an impact list showing effects of a change throughout a design hierarchy in accordance with one embodiment of the invention;

Figure 75 shows an example flowchart display derived from a design matrix according to one embodiment of the invention;

20 Figure 76 shows an example Gantt chart derived from the flowchart shown in Figure 75;

Figures 77A-D show probability density functions according to one embodiment of the invention;

25 Figure 78 shows a user interface displaying a design document derived from a design according to one embodiment of the invention;

Figures 79A-B show horizontal and vertical type design trees, respectively;

Figure 80 shows a user interface that indicates a completeness of a design according to one embodiment of the invention;

30 Figure 81 shows one process used to manipulate a design matrix according to one embodiment of the invention;

Figure 82 shows one process that checks status of a design according to one embodiment of the invention;

Figure 83 shows one process that determines whether elements of the design are undefined according to one embodiment of the invention;

Figure 84 shows one process that determines whether a design is uncoupled according to one embodiment of the invention;

5 Figure 85 shows one process that determines whether a design is coupled according to one embodiment of the invention;

Figure 86 shows one process that generates rearranged sequences of a design matrix according to one embodiment of the invention;

10 Figure 87 shows a process that ranks alternative or redundant DPs according to one embodiment of the invention;

Figure 88 shows a process that ranks all permutations of DPs according to one embodiment of the invention;

Figure 89 shows a process that generates flowchart sequences based on design matrix information according to one embodiment of the invention;

15 Figure 90 shows one exemplary format of a flowchart matrix according to one embodiment of the invention;

Figure 91 shows a process for generating an impact list according to one embodiment of the invention; and

20 Figure 92 shows a process for generating a Gantt chart according to one embodiment of the invention.

Detailed Description

According to one embodiment of the invention, a new software design methodology is provided that is based on axiomatic design theory. In one aspect,
25 axiomatic design theory is adapted for use in designing object-oriented software programs. This methodology overcomes the shortcomings of various software design strategies including extensive software development and debugging time and the need for extensive maintenance. Because traditional software design strategies are not heuristic and do not provide basic principles for the development of good software
30 systems, bad design habits produce poor quality software. A design framework using axiomatic design for software overcomes many of the shortcomings of current software design techniques: high maintenance costs, limited reusability, the need for extensive

debugging and testing, poor documentation, and limited extensibility of the software, all of which result in high development cost of software.

According to one embodiment of the invention, a software designer or developer describes their software based on features which depends on the programming language or software design methodology. Axiomatic design methodology combines the concept of “what we want to achieve” and “how we want to achieve it” and is represented as a single concept in terms of axiomatic design. In particular, axiomatic design defines a concept of domains which isolates representation of the software system. A domain termed the functional domain captures the concept for “what we want to achieve” and indicates as elements of the domain a set of functional requirements (FRs). The physical domain represents “how we want to achieve it” and indicates as elements of the domain a set of design parameters (DRs). Two other domains exist. One is the customer domain which captures customer needs (CNs) defining customer requirements of the software system. The other is a domain termed the process domain that represents process variables (PVs) defining the existing environment in which the software system operates. All these domains are illustrated in Figure 1. By using FRs and DPs to describe software, a software designer can create a clear description for their software.

The specific nature of CNs, FRs, DPs and PVs of a software design depends upon the specific nature or goals of the software:

- CNs: Users’ needs or customer attributes which the software program must satisfy.
- FRs: Outputs or the specifications or the requirements of a program code or software module or a system.
- DPs: (1) Inputs or modules in case of pure algorithms or
(2) Hardware such as sensors, ASICs (application specific integrated circuits), or other hardware that interface with software systems.
- PVs: Program code (source code including subroutines, modules, or the like, or machine code) or compilers.

Various advantages of designing software using axiomatic design principles using a software production methods and systems according to various embodiments of the invention include:

- **Guarantees the quality of software.** A design matrix may be used to describe a relation between FRs and DPs. The design matrix can be represented as Equation (1) in mathematical manner. If the design matrix is diagonal, each of the FRs can be satisfied independently by means of one DP. Such a design is called an uncoupled design. If the matrix is triangular, the independence of FRs can be guaranteed if and only if the DPs are changed in a proper sequence. Such a design is called a decoupled or quasi-coupled design. All other cases are referred to as a coupled design. Figure 2 shows these different types of designs. If the design matrix for the software is uncoupled or decoupled, it guarantees software quality or “goodness”.

10

$$\{FRs\} = [A]\{DPs\}$$

$$[A] = \begin{bmatrix} A_{11} & A_{12} & A_{13} \\ A_{21} & A_{22} & A_{23} \\ A_{31} & A_{32} & A_{33} \end{bmatrix} \quad (1)$$

$$A_{ij} = \frac{\partial FR_i}{\partial DP_j}$$

- **Improve reusability:** The FRs, DPs and PVs are decomposed until the design can be implemented without further decomposition to create a design hierarchy. Decomposition of FRs, DPs, and PVs are not accomplished by determining a solution in a single domain, but rather designs are determined by working recursively between domains, referred to as “zigzagging” between the domains. Decomposition of FRs is generally performed until the design task can be implemented without further decomposition.

20 The design hierarchy may have a different shape depending on a higher-level design decision, meaning that if a designer selects different DPs for one level to make an uncoupled or decoupled design, the child level information may vary depending on the DP selection. This design feature improves reusability because lower-level details of a program do not require modification if changes are made at a higher level of the design hierarchy. For example, after a company designs their software using axiomatic design principles, they may want to choose previously-designed DPs for their new software project. Decomposition for the previously-designed DPs are not required; only a small amount of modification of the source code which represents the previously-designed DPs

and their associated lower level hierarchies to fit the new project may be needed.

Therefore, the result of each individual software development project can be stored in a storage structure such as a design database and referred to by a programmer at any time.

- 5 • **Low maintenance cost:** The system architecture (sometimes referred to as a flow diagram or flow chart) reveals the design sequences between the modules which is defined in terms of the (FR/DP) or (DP/PV) relationship. Figure 3 shows several different junction types through which modules may be connected, these junctions representing relationships between modules. This figure is determined by the design
10 matrix. Once a software is design finished, it is much easier to follow changes during the development and maintenance processes. Because the developer or manager knows how the software modules interact and which module should be checked if a change is made, maintenance cost is reduced. Figure 4 shows an example system architecture.

- 15 • **Reduce extensive debugging and testing:** Because a programmer does not directly code first, debugging and testing is minimized. In particular, the axiomatic design method forces a programmer to develop a design prior to coding the design. Detailed information for the design is defined during the design process. Therefore,
20 software coding is straightforward. If there is something wrong with the software code, a designer or programmer analyzes and revises the design document which represents and determines the specific code. Also, the developed software can be tested with the FRs information step by step, because the FRs each represent specific software requirements.

- 25 • **Provides clear documentation:** Axiomatic design requires determining the FRs, DPs, PVs and design matrix prior to coding. According to one aspect of the invention, descriptions have a same format and contain notes such as keywords, comments and the like. According to another embodiment of the invention, a design document is automatically defined by a software production system based upon the actual design that
30 allows communication between designers, managers, and developers. Automatic documentation for software is beneficial, because documentation is standardized among programmers and more time may be devoted to development in lieu of writing software documentation.

• **Guarantees extensibility of the software:** As discussed, conventional software systems are generally coupled systems having feedback. Thus, it is typically difficult to extend the previously-developed software because, in a system having feedback, a change in one module may have an adverse affect on the operation of another system. In most cases, new software that entirely replaces the previously-developed software is needed to incorporate new features. To resolve coupling in systems, the relationship between each individual feature should be checked and this checking requires detailed information regarding the system. Currently, there are no methods for revealing this coupling in current software designs. Analysis of a system is currently performed manually by designers or programmers' intuition (referred to as ad-hoc design).

Axiomatic design provides design tools such as tools for creating a design matrix and system architecture. By using these axiomatic design tools, creating or extending a software system is straightforward. For example, to extend an existing system, the following steps are typically performed: add the required feature for the extension in terms of FR/DP or DP/PV, check the relation using the design matrix and determine if any modules are impacted by the change and adjust the program accordingly. If a designer determines an uncoupled or decoupled design using these axiomatic design tools, the extension is automatically verified.

20

• **Reduces development costs of software:** High costs are associated with long software development, and debugging time, the need for maintenance, and uncertain reliability. In general, software development is a labor-intensive business. Because every single development process in the software development life cycle is conducted clearly and sequentially, delays drastically affect the overall development cycle. By implementing axiomatic design principles, designers and managers can determine the state of the development process and can estimate the next step rather than treating software as a block box. This knowledge provides designers and managers more opportunities to reduce development cost.

30

The goals of software engineering should be twofold: first algorithmic efficiency should be enhanced so as to reduce execution time. Second, productivity should be enhanced so as to reduce coding, extension, and maintenance effort. As computer hardware rapidly evolves and the need for large-scale software systems grows,

productivity is increasingly more important in software engineering. The so-called “software crisis” is closely tied to productivity of software development [R.S. Pressman, Software Engineering, A Practitioner’s Approach, 4th ed., New York: McGraw Hill, 1997].

5 Several design methodologies for software systems have been proposed in the past. Two decades ago, structured methods, such as structured design and structured analysis, were most commonly used [T. DeMarco, Structural Analysis and System Specification, New Jersey: Prentice Hall, 1979]. Structured methods focus on only the process and generally follows a top-down approach. Therefore, another concept
10 (referred to as a data structure) used to represent data was introduced. As the need for productive software systems has increased, the object-oriented method has become the basic programming tool which follows a bottom-up design approach [B.J. Cox, Object-Oriented Programming, Reading, Massachusetts, Addison-Wesley, 1986]. Object-oriented programming emphasizes the need to design software right during the early
15 stages of software development and emphasizes the importance of modularity of objects that include process and data together. However, even with object-oriented methods, there are many problems that intelligent software programmers face in developing and maintaining software over its life-cycle. Although there are several reasons for these difficulties, the main reason is that the current software design methodology does not
20 provide any criterion by which a developer can create good software a priori. Modularity alone does not assure good software, since even a set of independent modules can couple software functions.

The axiomatic design (AD) approach has been used primarily for design of mechanical systems and has been proposed for software design in particular [S.J. Kim,
25 N.P. Suh, and S.K. Kim, “Design of software systems based on axiomatic design,” Annals of the CIRP, Vol. 40, No. 1, pp. 165-170, 1991]. In axiomatic design, a scientific approach is used for the design process that had previously been conducted heuristically or in an ad-hoc manner. The design process begins with the definition of functional requirements (FRs). The axiomatic design process is generally described as
30 the mapping between functional and physical domains and also between the physical and process domains. During the mapping process, two axioms – the Independence Axiom and the Information Axiom – must be satisfied. The design task includes satisfying a set of specified FRs of the functional domain by mapping FRs to design parameters (DPs) in

the physical domain as shown in Figure 1. FRs and DPs are decomposed through zigzagging until the design goals can be implemented. These mapping and zigzagging processes assist designers to generate successful designs, as software design is approached in an organized and deterministic manner. Also, axiomatic design principles can be applied to many system design problems. Further, because axiomatic design principles are mathematically-based and described using common engineering terms, the design principles are relatively easy for engineers to understand.

The AD approach or framework has been successfully applied to software design. However, according to one aspect of the invention, axiomatic design theory is applied to object-oriented design methods to create a software system in a systematic and productive manner. The basic idea used for the design and development of software systems is similar to that used for hardware components and other systems, and thus the integration of software and hardware design is a straightforward exercise for the software developer.

There are similarities between the AD framework and the object-oriented method which can be used to relate the two. For example, the concept of “inheritance and aggregation” in the object-oriented method is similar to the “tree structure” in the AD framework. Also, an “association” in the object-oriented method represents a part of the concept embedded in the “design matrix” of the AD framework. There are several differences, however, between the AD framework and current object-oriented software design methodologies. These differences become apparent as details of axiomatic design and object-oriented method are compared. Simply stated, the object-oriented method deals only with the DPs (implementation details) and not the FRs (function requirements of the system) of axiomatic design, and thus it is difficult to verify that the software design is good a priori. Another difference is that the AD framework implements a top-down approach to create a complete hierarchy of FRs and DPs by a zigzagging process between the domains until lowest level FRs and DPs (i.e., leaves) are created, whereas the object-oriented method can be completed by a bottom-up approach. Axiomatic design principles allow a programmer to use both methods to realize a software system. The AD framework supports both benefits from structured methods and object-oriented methods and provides criteria for design decision making in order to create quality software systems.

Introduction

The development of a software system based on axiomatic design and object oriented programming technique is described. According to one aspect of the invention, axiomatic design of object-oriented software systems provides a major new paradigm shift in the field of software engineering. This new method combines the power of axiomatic design with a popular software programming methodology referred to in the art as the object-oriented programming technique (OOT). One goal of this method is to make software development processes a subject of science rather than an ad-hoc art, thus reducing and/or eliminating the need for debugging and extensive software changes.

In software engineering, it is well known that software should be developed or written with independent modules. However, conventional module used in typical software does not meet the rigid definition of a module used in axiomatic design. In particular, these modules are defined as Equation (2). Also, collections of conventional modules are generally coupled. Furthermore, the decomposition of software is often performed in the heads of the programmers based on their experience; programmers do not explicitly define FRs, perform mapping or zigzagging to define a system, nor do they write down design equations related to that system. Therefore, the use of independent modules themselves does not generate uncoupled software design. To create quality software, the relationship between the modules should be designed to make them work independently and explicitly. These shortcomings can be overcome by designing software first based on axiomatic design principles.

$$M_i = \sum_{j=1}^{j=i} \frac{\partial FR_i}{\partial DP_j} \frac{\partial DP_j}{\partial DP_i} \quad (2)$$

In particular, the AD framework disclosed herein ensures that the modules are correctly defined and located in the right place, and in the right order. A “V model” concept was recently introduced to improve the quality in mechanical system [B. El-Haik, “The Integration of Axiomatic Design in the Engineering Design Process”, 11th Annual RMSL Workshop, May 12, Detroit, U.S.A, 1999]. Because the idea of V-models may be adapted for software production, a modified version of the “V model for software” is disclosed here which adapts the idea of using object-oriented software design within the AD framework.

The V-model process as applied to object-oriented programming includes three general steps. First, the process designs the software system based on axiomatic design, i.e., decomposition of FRs, DPs and PVs, the design matrix, and the modules as defined by axiomatic design. Second, the process represents the software design using a full design matrix table and a flow diagram, which provide the well-organized structure for software development. Third, the process builds the software system based on the flow diagram and DP/PV relation using object-oriented concepts. This axiomatic approach enhances software productivity because it provides a roadmap for designers and developers of the software system and eliminates functional coupling between elements. Figure 5 schematically represents the process, which will be explained in more detail later in this section.

Definition of Terminology for Object-Oriented Software Systems

One of the difficulties associated with learning Object-Oriented techniques (OOT) is the definition of key words that describe object-oriented methods. For example, Table 1 depicts the plurality of key words used to describe the same concepts in object-oriented programming. In this section, OOT is described by using the keywords used in OOT and equivalent terms are shown below with respect to Table 1 below:

Developed by	Class	Association	Generalization	Aggregation
Booch	Class	Has	Inherits	Containing
Coad	Class & Object	Instance Connection	Gen-Spec	Part-Whole
Jacobson	Object	Acquaintance Association	Inherits	Consist of
Odell	Object Type	Relationship	Subtype	Composition
Rumbaugh	Class	Association	Generalization	Aggregation
Shlaer / Mellor	Object	Relationship	Subtype	N/A

Table 1 - Several Definitions for the class structure

Object-oriented methodology (OOM) is generally a conceptual process that is independent of any programming language until a final code creation stage. OOM is a formal method of creating a software structure and abstraction, helping designers to

express and communicate abstract concepts. The fundamental construct for the object-oriented method is the object, which, according to one embodiment of the invention, is equivalent to FRs. Object-oriented design decomposes a system into objects. Objects “encapsulate “ both data, and methods in a single entity. According to one embodiment, data are equivalent to DPs and methods are equivalent to relationships between FRs and DPs, i.e., a module. An object retains certain information on how to perform certain operations, using the input provided by the data and the method imbedded in the object. In terms of axiomatic design, this is equivalent to saying that an object is $[FR_i = A_{ij} DP_j]$. A graphical representation of an object is shown in Figure 6.

Object-oriented design generally uses four definitions to describe its operations: identity, classification, polymorphism and relationship. Identity means that data -- equivalent to DPs in one embodiment -- are incorporated into specific objects. Objects are equivalent to an FR -- with a specified $[FR_i = A_{ij} DP_j]$ relationship -- of axiomatic design, where DPs are data or input and A_{ij} is a method or a relationship.

In axiomatic design, the design equation explicitly identifies the relationship between FRs and DPs. The term classification means that objects with the same data structure (attributes) and behavior (operations or methods) are grouped into a class. The object is typically represented as an instance of specific class in programming languages. Therefore, all objects are instances of some classes. A class represents a template for several objects and describes how these objects are structured internally. Objects of the same class have the same definition both for their operations and for their information structure.

The term polymorphism means that the same operation may behave differently on different classes and therefore, two or more classes of objects respond to a received message each in its own way. A move operation, for example, may behave differently on Window and Chess Piece classes of a game program. The term, relationship describes the interactions between objects or classes. These interactions can be of the following types as shown in Figure 7. Figure 7 is a block diagram illustrating J. Rumbaugh’s well-known object model notation [J. Rumbaugh, M. Blaha, W. Premerlani, F. Eddy, and W. Lorenzen, Object-Oriented Modeling and Design, New Jersey: Prentice Hall, 1991].

Relationships between objects and classes are established by means of Links and associations [J. Rumbaugh, M. Blaha, W. Premerlani, F. Eddy, and W. Lorenzen,

Object-Oriented Modeling and Design, New Jersey: Prentice Hall, 1991][G. Booch, Object-Oriented Analysis and Design with Applications, 2nd ed., California: The Benjamin/Cummings Publishing Company, Inc., 1994]. A link is a physical or conceptual connection between objects. An association represents a group of bi-directional links with common structure and common semantics. Aggregation refers to the “part-whole” or “a-part-of” relationship in which objects representing the components of an object that represents the entire assembly. Sharing similarities between classes while preserving their differences is encapsulated in generalization and inheritance. Inheritance allows the conception of a new class of objects as a refinement of another and abstraction of the similarities between classes. Generalization defines the relationship between a class and one or more refined versions of it. A superclass is the class being refined and a subclass is a class that inherits behavior from another class, which is a refined version of the superclass. Attributes and operations common to a group of subclasses are attached to the superclass and shared by each subclass, which inherits the features of its superclass. Generalization and inheritance are typically transitive across an arbitrary number of levels.

The following software design sequence describes the object-oriented technique based on these concepts:

1. Define the problem or task.
2. Identify objects and their attributes and input data.
3. Identify operations that may be applied to objects.
4. Establish interfaces by showing the relationship between objects and operations.
5. Repeat steps 1, 2, 3, and 4.

Steps 2 and 3 are summarized collectively as steps related to object-oriented class definition. These steps are commonly referred to as modeling or analysis. Step 4, usually referred to as the design step, utilizes diagrams such as a data flow diagram and an Entity-Relation (ER) diagram to realize the relationships. As shown in Figure 8, an object diagram is generated when all these design steps are finished. At this stage, it is difficult to determine whether the design represented by an object diagram is good because no criterion exists in terms of design verification; this is a shortcoming of conventional OOT.

An example of an object diagram is described below with respect to Figure 8, wherein the numbers indicate the number of associations [Rumbaugh, 1991]:

- a. Each box is a class or an object. The top section of the box (e.g., **Box** in the left top box of the figure) is the name of the class, the middle section of the box (e.g., **text** in the figure) describes the attributes of the class, and the bottom section of the box (e.g., **cut**) defines the operations of the class.
- 5 b. An object is represented as an instance of specific class (e.g., Object **Box** is an instance of **Box** class). However, sometimes each box in Figure 8 may be called as an object.
- c. Object **Link** has two relationships with the attributes of object **Box**.
- d. Object **Collection** is an aggregation of the attribute of **Box** and the
10 operation of **Link** with many relationships. That is, object **Collection** can have many **Box** and **Link** objects.
- e. Object **Collection** is the superclass of subclasses **Selection, Buffer and Sheet**.
- f. Object **Drawing**, which has a relationship with object **Drawing** file, can
15 have many **Sheet** objects.
- g. Object **Link** is an aggregation of object **Line segment**, which in turn is an aggregation of object **Point**. That is, object **Line segment** is a part of object **Link** with many relationships.

20 Modified Object-Oriented Method Incorporating Axiomatic Design Principles

The following describes a method for modifying object-oriented design methods to incorporate axiomatic design principles in accordance with various embodiments of the invention. All examples merely illustrate inventive concepts, and the spirit and scope of the invention should not be limited thereto.

25 In object-oriented systems, there are two types of object diagrams: class diagram and instance diagram. A class diagram is a schema, pattern, or template for describing many possible instances of data. A class diagram describes object classes. An instance diagram describes how a particular set of objects relates to each other. An instance diagram describes object instances. Figure 9 is a block diagram showing an example
30 object class and instance diagram. In particular, a person class may be defined having a name (string) and an age (integer). An instance of the Person class, namely "Bob Powers" or "Derrick Tate" are instantiations of the Person class. These instantiations include values for the names and ages of each person.

An object is linked to other objects through messages, which require an object to perform certain functions by executing a method (i.e., algorithm). The object performs the function using the internal operations that may not be apparent to other objects – equivalent to the elements of the design matrix that link specific FRs to specific DPs.

5 An “Object” may have several activities depending on how they structured and sometimes these activities are called “Behavior”. According to one embodiment of the invention, behavior is a special case of FR. The relationship between FRs and “Class”, “Objects” and “Behavior” may be described in terms of the design hierarchy as shown in Figure 27. The highest FR among the three layers of decomposed FRs is “Class”, the
10 children FRs of “class FR” is “Object” which may represent aggregation or generalization, and the grandchildren FRs of “class FR” are “Behavior”. If there is no items for “Object” for the second level, it is possible to treat the grandchildren FRs as children FRs.

The distinction between “Super Class”, “Class”, “Object” and “Behavior” is
15 necessary in Object-Oriented Technique (OOT) to deal with FRs at successive layers of a system design. In OOT, the Class represents an abstraction of Objects and thus, is positioned one level higher than an Object in the FR hierarchy. Similarly, the Object is one level higher than Behavior in the FR hierarchy. The use of these keywords, while necessary in OOT, adds unnecessary complexity when the results of axiomatic design is
20 to be combined with OOT. Therefore, the use of these keywords in OOT will be modified to describe axiomatic design principles.

One key word “Object” is used hereinafter to represent all three levels of FRs, i.e., Class, Object, and Behavior. “Objects with indices” is used in place of these three keywords. For example, Class may be called Object i to present FR_i , Object is denoted
25 as “Object ij ” to represent the next level FRs, FR_{ij} , and Behavior – the third level FRs -- is denoted as Object ijk . Thus, Object i , Object ij , and Object ijk are equivalent to FR_i , FR_{ij} , and FR_{ijk} , which are FRs at three successive levels of the FR hierarchy.

To summarize, the equivalence between the terminology of axiomatic design and those of OOT according to one embodiment of the invention may be stated as:

- 30
- A FR can represent an Object.
 - DP can be data or input for the Object, i.e., FR.
 - The product of a module of the design matrix and DP can be a method, i.e., $FR = A * DP$.

- Different levels of FRs are represented as Objects with indices.

Basics of Axiomatic Design of Object-Oriented Software Systems

An exemplary axiomatic design process for designing object-oriented software systems is shown in Figure 5. The process includes the following steps:

5 i. Define FRs of the Software System

The first step in designing a software system is to determine the customer attributes in the customer domain that the software system must satisfy. Then, the functional requirements (FRs) of the software in the functional domain and constraints (Cs) are established to satisfy the customer needs. FRs must satisfy the customer needs
10 with fidelity.

ii. Mapping between the Domains and the Independence of Software Functions

The next step in axiomatic design is to map these FRs of the functional domain into the physical domain by identifying the design parameters (DPs). DPs are the “how’s” of the design that satisfy specific FRs. DPs are chosen to be consistent with the
15 constraints. During the mapping process, the design must satisfy the Independence Axiom, which requires that functional independence be maintained throughout the development of an uncoupled or decoupled design. A design matrix is used for this evaluation.

iii. Decomposition of {FRs}, {DPs}, and {PVs}

The FRs, DPs, and PVs are decomposed until the design can be implemented without further decomposition. These hierarchies of {FRs}, {DPs}, {PVs} and the corresponding matrices represent the system architecture. The decomposition of these vectors generally are not done by remaining in a single domain, but are done through zigzagging between domains. This zigzagging concept is shown in Figure 10. From
25 FR1 in the functional domain, the designers develop DP1 in the physical domain. Then, the designers return to the functional domain to generate FR11 and FR12 that collectively satisfy the highest level FR1 and the corresponding DP1. Then the designers move to the physical domain to determine DP11 and DP12, which satisfy FR11 and FR12, respectively. This process continues until the FRs can be satisfied without further
30 decomposition. Each terminal FR and DP (those which are not further decomposed) is called a “leaf” in the tree structure.

As software is designed, the PVs are described in terms of programming terminology such as packages, classes, attributes, methods and so on. Although object-

oriented programming languages apply, this method may be applied to any kind of programming language. According to one embodiment of the invention, the relationship between DPs and PVs is exactly same for the software system. Therefore, the relation for FRs and PVs is straightforward. As a result, the PV hierarchy shows the programming structure.

The software design methodology which was favored in mid '70s and '80s, uses similar decomposition with the top-down approach. As shown in Figure 11, Structured Analysis and Design Technique (SADT) is a well-known example of this approach. However, SADT is only conducted in the physical domain from an axiomatic design viewpoint and the process is decomposed without consideration of data. Because of this non-zigzagging process, there is no guarantee of functionality or productivity. Therefore previous methods faded away as the requirement for productive software system increased and object-oriented methods were introduced.

iv. Definition of Modules – Full Design Matrix

One of the most important features of the AD framework is the design matrix, which provides the relationships between the FRs and DPs. The design matrix provides two important bases in creating software. One important basis is that each element in the design matrix can be a method (or operation) in terms of the object-oriented method. The other basis is that each row in the design matrix represents a module to satisfy a specific FR as defined by Equation (2). In most cases, the off-diagonal terms in the design matrix are more important than the diagonal terms since most of the coupling comes from these off-diagonal terms. However, it is possible to avoid coupling with a proper sequence of change if the design matrix is triangular. An off-diagonal term can be represented as a message transfer (or function call) in the software system. Figure 12 illustrates these concepts of relating FRs and DPs in a design matrix, and representing a module by an element of the design matrix.

As illustrated in Figure 13, it is important to construct the full design matrix based on the leaf information in the software system. In the example shown in Figure 13, a decomposition of FRx.2 reveals a relationship between DPx.2.3 and FRx.1, while before decomposition, no relationship was identified. Advantages of this full design matrix include refining the module information precisely and checking the consistency between the hierarchy levels. Consistency can be defined as an activity in which the designers check the layers of the design hierarchy against each other to make sure that

the layers are consistent with one another [D.F. Baldwin, "Microcellular Polymer Processing and the Design of a Continuous Sheet Processing System," Doctoral Thesis, Massachusetts Institute of Technology, U.S.A, 1994][D. Tate, "A Roadmap for Decomposition: Activities, Theories, and Tools for System Design," Doctoral Thesis, 5 Massachusetts Institute of Technology, U.S.A, 1999]. If an off-diagonal term is shown in a different location which is not shown in a higher level, the designer should reconsider the relationship again to correct this inconsistency. The FRs, DPs, design matrices, and Cs should all be checked.

v. Identify classes – objects, attributes, and operations

10 Because all the DPs in the design hierarchy are selected to satisfy FRs, it is relatively easy to identify the objects. The leaf is the lowest level object in a given decomposition branch, but all leaf-level objects may not be at the same level if they belong to different decomposition branches. Once the objects are defined, the attributes (or data) – DPs -- and operations (or methods) – products of module times DPs -- for the 15 object should be defined to construct the object model. This activity should use the full design matrix table.

The following example illustrates an example process of designing an object-oriented system using axiomatic design principles.

20 **Example: Software Design for a Simple Line Drawing Program**

Problem:

Design a software program that can draw a straight line. Translate the resulting axiomatic design into object-oriented methods.

25 **Solution:**

The highest level FRs may be stated as,

FR1: Define line element

FR2: Detect the drawing location

FR3: Draw the line element through the window

30

The corresponding DPs are selected as,

DP1: Line characteristic

DP2: Mouse click information

DP3: GUI for the drawing

The design matrix may be written as,

$$5 \quad \begin{Bmatrix} FR1 \\ FR2 \\ FR3 \end{Bmatrix} = \begin{bmatrix} A11 & 0 & 0 \\ 0 & A22 & 0 \\ A31 & A32 & A33 \end{bmatrix} \begin{Bmatrix} DP1 \\ DP2 \\ DP3 \end{Bmatrix} \quad (a)$$

The FRs and DPs may be decomposed as:

Second Level for FR1

10

FR11: Define start

FR12: Define end

DP11: Start point

15

DP12: End point

The design matrix may be written as,

$$20 \quad \begin{Bmatrix} FR11 \\ FR12 \end{Bmatrix} = \begin{bmatrix} a & 0 \\ 0 & b \end{bmatrix} \begin{Bmatrix} DP11 \\ DP12 \end{Bmatrix} \quad (b)$$

Second Level for FR2

FR21: Detect mouse push

FR22: Detect mouse release

25

DP21: Event for push

DP22: Event for release

The design matrix may be written as,

$$30 \quad \begin{Bmatrix} FR21 \\ FR22 \end{Bmatrix} = \begin{bmatrix} c & 0 \\ 0 & d \end{bmatrix} \begin{Bmatrix} DP21 \\ DP22 \end{Bmatrix} \quad (c)$$

Second Level for FR3

FR31: Prepare the drawing environment

FR32: Draw the line

DP31: Window type

5 DP32: Graphics Information

The design matrix may be written as,

$$\begin{Bmatrix} FR31 \\ FR32 \end{Bmatrix} = \begin{bmatrix} e & 0 \\ f & g \end{bmatrix} \begin{Bmatrix} DP31 \\ DP32 \end{Bmatrix} \quad (d)$$

10 The above design can be expressed in OOT format as shown below in Table (2):

	Object 1 (for FR1)		Object 2 (for FR2)		Object 3 for (FR3)	
Second Level Objects (Behavior in OOT)	Object 11 (for FR11): Define start	Object 12 (for FR12): Define end	Object 21 (for FR21): Detect mouse push	Object 22 (for FR22): Detect mouse release	Object 31 (for FR31): Prepare the drawing environment	Object 32 (for FR32): Draw the line
Attribute or Data	DP11: Start point	DP12: End point	DP21: Event for push	DP22: Event for release	DP31: Window type	DP32: Graphics Information
Operation or Method	$a*DP11$	$b*DP12$	$c*DP21$	$d*DP22$	$e*DP31$	$f*DP31+g*DP32$

Table 2 - Two Different Levels of Objects

The top box of the four tiered object box in Table 2 is for the name of the Object for FRs. The second boxes are for the second level FRs (in OOT, was called Behavior), i.e., FR11, FR12, FR21, etc. The “data”, which are DP11 and DP12 and so on, are in the third tier boxes. The fourth tier boxes are for methods (or operations), which are $a*DP11$, $b*DP12$ and so on. We can keep the parent level relationships (i.e., FR1-A11-DP1, FR2-A22-DP2 and FR3-A33-DP3) in a library for future reuse; this assures reusability since each one of these relation reveals the fundamental object structure.

The sets (FR1-A11-DP1), (FR2-A22-DP2) and (FR3-A33-DP3) are named as Object 1d for FR1, Object 2d for FR2 and Object 3d for FR3, respectively. The character “d” is added to the object number to denote the fact that they represent only the diagonal element. The off-diagonal terms are then processed. This processing can be

done if we call (FR3-A31-DP1 / FR3-A32-DP2) as Object 3* for FR3*. The asterisk sign is used to denote the off-diagonal elements. Then, FR3 is “Object 3 for FR3”, which is an “aggregate” of Object 3d for the diagonal element of FR3 and Object 3* for FR3*. These relationships can be represented in terms of the OOT notation as shown in Figure 14.

The full design matrix with FRs and DPs can be translated into the OOT structure as shown in Figure 15. Figure 16 shows a more detailed correspondence between the full design matrix and the OOT diagram. This translation is illustrated further in Figure 17 which shows a block diagram of an object oriented system according to the full design matrix shown in Figure 16. In the example case, wherein the FRs are equivalent to objects, and the DPs are equivalent to data.

vi. Establish interfaces by showing the relationships between objects and operations

Most efforts are focused on this step in the object-oriented method since the relationship is the key feature. However, it lacks information about functional relationships since the relationship is only represented as lines between objects (or classes) as shown in Figure 17. To overcome this lack of information, the axiomatic design methodology provided herein utilizes the off-diagonal element in the design matrix as well as the diagonal elements at all levels. A design matrix element represents a link or association relationship between different FR branches that have totally different behavior. All these concepts are illustrated in Figure 17 which shows the object-oriented structure corresponding to the design matrix shown in Figure 16.

One of the advantages of the AD framework is that it represents the inter-relationships among modules in the design hierarchy. To represent the properties of junctions at each level of decomposition, a “Module-Junction Structure Diagram” is defined [S.J. Kim, N.P. Suh, and S.K. Kim, “Design of software systems based on axiomatic design,” *Annals of the CIRP*, Vol. 40, No. 1, pp. 165-170, 1991 {also *Robotics & Computer-Integrated Manufacturing*, 3:149-162, 1992}]. Based on the AD framework, a “modular design” may not necessarily be a good design, because these modules must be properly arranged and must satisfy the Independence Axiom. In a complex design, this can only be performed if modules are defined consistent with Equation (2).

To represent the relationships between modules, symbols in circles are used as shown in Figure 18. For an uncoupled design, **S** in the circle is used to represent a

simple summation of FRs. **C** in the circle indicates that DPs and modules must be controlled in a sequence as suggested by the design matrix for a decoupled design. **F** in the circle is used to indicate that the design is coupled, indicating that it requires feedback and violates the Independence Axiom.

5 The module-junction structure diagram is shown in Figure 18 for the design given by Equation (3) shown below. It should be noted that the higher-level modules are obtained by combining lower-level modules. For example, by combining modules M121, M122, and M123 with a control junction (**C**), we obtain the next higher-level module M12. Then, M11 and M12 are combined to obtain M1 using a control junction
10 (**C**) again. M1 and M2, although not shown since they are not leaves, are simply summed as indicated by symbol S.

$$\begin{aligned}
 \begin{cases} FR1 \\ FR2 \end{cases} &= \begin{bmatrix} X & 0 \\ 0 & X \end{bmatrix} \begin{cases} DP1 \\ DP2 \end{cases} \\
 \begin{cases} FR11 \\ FR12 \end{cases} &= \begin{bmatrix} X & 0 \\ X & X \end{bmatrix} \begin{cases} DP11 \\ DP12 \end{cases} \\
 \begin{cases} FR21 \\ FR22 \\ FR23 \end{cases} &= \begin{bmatrix} X & 0 & 0 \\ X & X & 0 \\ 0 & X & X \end{bmatrix} \begin{cases} DP21 \\ DP22 \\ DP23 \end{cases} \\
 \begin{cases} FR121 \\ FR122 \\ FR123 \end{cases} &= \begin{bmatrix} X & 0 & 0 \\ X & X & 0 \\ X & 0 & X \end{bmatrix} \begin{cases} DP121 \\ DP122 \\ DP123 \end{cases} \\
 \begin{cases} FR1231 \\ FR1232 \end{cases} &= \begin{bmatrix} X & 0 \\ X & X \end{bmatrix} \begin{cases} DP1231 \\ DP1232 \end{cases}
 \end{aligned} \tag{3}$$

vii. Construct the system architecture of the software system

20 When the AD framework is used, the entire process can be clearly shown by a flow chart that represents the system architecture. The symbols used in the flow chart is illustrated for uncoupled, decoupled and coupled designs in Figure 3. Figure 4 shows the final flow diagram for the design represented by Equation (3). In particular, Figure 4 shows how the system represented by Equation (3) can be structured using the modules.
25 The sequence of software development begins at the lowest level, which is defined as the leaves. To achieve the highest-level FRs, which are the final outputs of the software, the development of the system begins from the inner-most modules shown in the flow chart that represent the lowest-level leaves. Then, the next higher level modules are developed (i.e., next inner-most box) following the sequence indicated by the system architecture;

that is, a developer develops from the inner most boxes to the outer most boxes. In summary, the software system can be developed in the following sequence:

- a. Construct the core functions using diagonal elements of the design matrix.
- b. Create a module for each leaf FR, following the sequence given in the flow chart
5 that represents the system architecture.
- c. Combine the modules to generate the software system, following the module
junction diagram.

When this procedure is followed, the software developer can reduce the coding time because the logical process reduces the software construction into a routine
10 operation. The process also guarantees a minimal effort for maintenance and extension in the event that they are required in the future.

The right side of the V-model shown in Figure 5 may be used for any software design methodologies. However, the Object-Oriented method is used in most commercial software products, which typically use the C++ or JAVA programming
15 languages. The right side of the V-model can be replaced by SADT, but now SADT has been replaced by OOT.

Software Design Database

In accordance with one aspect of the invention, a software design database is
20 provided that is used to store aspects of a software design implementing axiomatic design principles. One or more of the features of the design database provide the following:

- Search by design parameters (DPs) information (including description, keyword, comments, categories and so on) among all the possible DPs.
- 25 • Provide several results which has functional requirements (FRs), design parameters (DPs), process variables (PVs) and design matrix with the design hierarchy.
- Provide graphical representation for the selected design hierarchy in terms of Unified Modeling Language (UML). The graphical representation could be, for example, a Class diagram, Activity diagram, Flow diagram, Package diagram, etc.

30 Axiomatic Design theory encourages designers to find out the proper design parameters (DPs) which makes uncoupled or decoupled effect for desired set of functional requirements (FRs). However, sometimes it is difficult to determine proper DPs in case of beginner or even expert designer. To avoid these difficulties, it is useful

to support the DPs candidate through a design database so that the design might get an idea of their specific FR/DP relationships. Software systems usually have some common functions named as “common libraries” between the software products. These common features are stored into each programmer’s computer as several files. Therefore it is kind of a measuring scheme for the programmer’s skill such that the programmer has many common libraries or not. If this kind of library stored into the database system and provided to the entire software designer, it is really useful to shorten the software design and development life cycle as well as improve reusability.

10 • **Improve reusability:** As discussed above, one of the key issues to use the axiomatic design concept according to one embodiment of the invention includes selecting proper DPs to make an uncoupled or decoupled design. Based on the axiomatic design, only one DP should be assigned for specific FRs among all the other alternatives. If a DP has enough information such as child level design structure, the designer does not need to further decompose that level since all the necessary design hierarchy is by though the child level. Therefore, the usage of database system, which includes DP information with a pre-proven design hierarchy, improves the reusability of the software system. A common library function is an example of the database content for the software system according to one embodiment of the invention. Ideally, the result of each individual software development project can be stored as design database and each level DPs may be referred at any time for the different project.

25 • **Low maintenance cost:** As discussed, the information stored into the design database is pre-proven, which means each level of the design hierarchy should be uncoupled or decoupled in terms of its axiomatic design. As long as this condition is satisfied, the usage of pre-proven design database does not require debugging or testing for the given DPs. The only required work to implement this design database as a DP includes checking the inconsistency between a level which has DPs from the design database and its child level and test the connection [D.F. Baldwin, “Microcellular Polymer Processing and the Design of a Continuous Sheet Processing System,” Doctoral Thesis, Massachusetts Institute of Technology, U.S.A, 1994][D. Tate, “A Roadmap for Decomposition: Activities, Theories, and Tools for System

30

Design,” Doctoral Thesis, Massachusetts Institute of Technology, U.S.A, 1999].

Therefore the usage of design database reduces the amount work to do and assures the low maintenance cost.

- 5 • **Low development cost of software:** Using the pre-proven design reduces development time, debugging, and testing time. These time savings reduce development costs of software.

To meet these ends, an efficient query as well as well defined database structure should be implemented. Current search engine requires words or/and phrases and
10 combination strategy between the words such as AND/OR combination. These kinds of query provide ambiguous results due to the lack of query information and the database structure. For example, Internet search engines such as Yahoo, Altavista and the like do not allow a user to determine answers to queries in a single step. Therefore, a user must try another effort to determine proper information through reviewing the results.

15 To overcome these ambiguities, a knowledge-based approach may be used. For instance, Invention Machine software from Invention Machine Corporation (IMC) may be implemented along with the software design system. The Invention Machine System [<http://www.inventionmachine.com>] provides organizations with easy access to a large knowledge-base 3-D animated scientific effects and technical examples. The Invention
20 Machine System also captures in-house technical knowledge and expertise, and improves the way technical knowledge is shared across the engineering enterprise, and conducts a competitive analysis by searching the U.S. and Japanese Patent Office database and comparing patent trends using a powerful charting feature. Therefore, the system suggests technical alternatives using predefined database upon the designers request but
25 the system is not involved in the designing of software.

The software design database according to various embodiments of the invention includes several fields such as descriptions, keywords, comments, categories and the like. The design database may include source code, object code, or any intermediary file format which describes the software system. According to one embodiment, the
30 software design database contains source code in separate file system so that the designer can access it. As many as the specific design cases added into this database, it can represent more specific design suggestions. According to one embodiment, information providing an index of the database is provided. This index information allows a

programmer to obtain proper information for the DPs candidate for the specific FRs of software design.

Design Database

In this section, the development and implementation of software design database is presented. This database design may also be used for other types of design cases.

A database is generally defined as an integrated collection of persistent data representing the information of interest for various programs that compose the computerized information system of an organization [A. Siberschats, H.F. Korth, and S. Sudarshan, Database System Concepts, 3rd Edition, McGraw Hill, 1998].

The software design database according to one embodiment of the invention includes two different pieces. One piece is the database itself to store detailed design specifications. The other piece is a file system having directory structure to contain the real source code based on the design specification. The database can be located on any kind of computer or computers connected through a communications network, or alternatively may be located on a single computer system.

The design database according to one embodiment of the invention may be implemented in the database environment as shown in Figure 19. The database located at the Company stores system designs used locally by the Company. Alternatively, the database located in the ADSI can have general design solutions. The ADSI provides several kinds of design solutions for the software design based on the programming environment. If the design solution is in the public domain, any software designer can use it freely. However, if the design solution is not published, the ADSI charges to use those design solutions.

Data Model for the Software Design Database

The data model represented in this section is based on Entity-Relationship model (ER model). Figure 20 shows an Entity-Relationship (ER) diagram for the database shown in Figure 19. The file system that is a part of the operating system may be used to implement various embodiments of the invention.

The database generally includes three major parts for storing design information. The first part represents the design identification. The second part shows the detailed design descriptions, and the third part is designed to store the source code information. Code for the design is stored into the file system, and is identified by name field in the

FILE table. Detailed database tables that store such design information according to various embodiments of the invention appear below in Tables 3-16.

No	Table ID	Table Description
1	DESIGN_SET	Setup the design identification
2	HISTORY	Relate between DESIGN_SET and REVISION
3	REVISION	Keep track the design changes
4	HIERARCHY	Relate between REVISION and DOMAIN
5	CN	Store customer needs (CNs) in customer domain
6	FR	Store functional requirements (FRs) in functional domain
7	DP	Store design parameters (DPs) in physical domain
8	CONSTRAINT	Store constraints information
9	EFFECT	Relate between CONSTRAINT and FR (FR/DP domain)
10	DM	Relate between FR and DP (FR/DP mapping)
11	OPERATION	Identify specific operation (i.e. method in the source file)
12	VARIABLE	Identify specific variable (i.e. attribute in the source file)
13	ATTRIBUTE	Relate between VARIABLE and DP
14	METHOD	Relate between OPERATION and DM

5

Table 3 - Database Table List

According to one embodiment of the invention, all the attributes in those generalized tables are shown its specialized table. For example, OPERATION and VARIABLE tables have its generalized table attributes such as name and description in their record. Figure 20 does not show the DP/PV relation because it is identical with the FR/DP relation.

10

Table ID		DESIGN_SET (Setup the design identification)			
Unique Index		DESIGN_CODE			
No	Record ID	Type	Length	Status	Description
1	DESIGN_CODE	String	10	PK1 (PK=primary key)	Identify the design
2	DESCRIPTION	String	80		Describe the design
3	KEYWORD	String	40		Categorize the design

Table 4 - Detailed information for DESIGN_SET table

15

Table ID		REVISION (Keep track the design changes)			
Unique Index		REVISION_CODE			
No	Record ID	Type	Length	Status	Description
1	REVISION_CODE	String	10	PK1	Identify the design changes
2	DESCRIPTION	String	80		Describe the changes

Table 5 - Detailed information for REVISION table

Table ID		HISTORY (Relate between DESIGN_SET and REVISION)			
Unique Index		DESIGN_CODE + REVISION_CODE			
No	Record ID	Type	Length	Status	Description
1	DESIGN_CODE	String	10	PK1	Identify the design
2	REVISION_CODE	String	10	PK2 (second primary key)	Identify the design changes
3	DATE	String	80		Specify the date for design changes

5

Table 6 - Detailed information for HISTORY table

Table ID		HIERARCHY (Relate between REVISION and DOMAIN (e.g. CN/FR/DP/PV))			
Unique Index		REVISION_CODE+CODE+PARENT+NUMBER			
No	Record ID	Type	Length	Status	Description
1	REVISION_CODE	String	10	PK1	Identify the design changes
2	CODE	String	20	PK2 (second primary key)	Identify the domain description
3	PARENT	String	20	PK3 (third primary key)	Indicate the zigzagging source
4	NUMBER	String	2	PK4 (fourth primary key)	Indicate the hierarchy number

Table 7 - Detailed information for HIERARCHY table

Table ID		CN (Store customer needs (CNs) in customer domain)			
Unique Index		CODE + PARENT + NUMBER			
No	Record ID	Type	Length	Status	Description
1	CODE (DESIGN_CODE + REVISION_CODE + domain name)	String	10	PK1	Identify the domain description
2	PARENT	String	20	PK2	Indicate the zigzagging source
3	NUMBER	String	2	PK3	Indicate the hierarchy number
4	DESCRIPTION	String	80		Represent the customer need description
5	KEYWORD	String	40		Represent the keyword for the customer need
6	COMMENT	String	300		Represent the comment for the customer need
7	LEAF	Boolean	1		Indicate the leaf / hierarchy

Table 8 - Detailed information for CN table

Table ID		FR (Store functional requirements (FRs) in functional domain)			
Unique Index		CODE + PARENT + NUMBER			
No	Record ID	Type	Length	Status	Description
1	CODE	String	10	PK1	Identify the domain description
2	PARENT	String	20	PK2	Indicate the zigzagging source
3	NUMBER	String	2	PK3	Indicate the hierarchy number
4	DESCRIPTION	String	80		Represent the FR description
5	KEYWORD	String	40		Represent the keyword for the FR
6	COMMENT	String	300		Represent the comment for the FR
7	CATEGORY	String	20		Represent the FR category
8	VERIFICATION	String	5		Represent the FR verification spec
9	LEAF	Boolean	1		Indicate the leaf / hierarchy

5

Table 9 - Detailed information for FR table

Table ID		DP (Store design parameters (DPs) in physical domain)			
Unique Index		CODE + PARENT + NUMBER + ALTERNATIVE			
No	Record ID	Type	Length	Status	Description
1	CODE	String	10	PK1	Identify the domain description
2	PARENT	String	20	PK2	Indicate the zigzagging source
3	NUMBER	String	2	PK3	Indicate the hierarchy number
4	ALTERNATIVE	String	2	PK4	Indicate alternative status
5	DESCRIPTION	String	80		Represent the DP description
6	KEYWORD	String	40		Represent the keyword for the DP
7	COMMENT	String	300		Represent the comment for the DP
8	CATEGORY	String	20		Represent the DP category
8	VERIFICATION	String	5		Represent the DP verification spec
10	LEAF	Boolean	1		Indicate the leaf / hierarchy

Table 10 - Detailed information for DP table

Table ID		CONSTRAINT (Store constraint information)			
Unique Index		CODE + PARENT + NUMBER			
No	Record ID	Type	Length	Status	Description
1	CODE	String	10	PK1	Identify the domain description
2	PARENT	String	20	PK2	Indicate the zigzagging source
3	NUMBER	String	2	PK3	Indicate the hierarchy number
4	DESCRIPTION	String	80		Represent the Constraint description
5	KEYWORD	String	40		Represent the keyword for the Constraint
6	COMMENT	String	300		Represent the comment for the Constraint
7	CATEGORY	String	20		Represent the Constraint category
8	VERIFICATION	String	5		Represent the Constraint verification spec
9	INITIAL_VALUE	String	10		Estimated value for budget
10	ACTUAL_VALUE	String	10		Actual value for budget
11	LEAF	Boolean	1		Indicate the leaf / hierarchy

5

Table 11 - Detailed information for CONSTRAINT table

Table ID		EFFECT (Relate between CONSTRAINT and FR (FR/DP domain))			
Unique Index		CODE1 + CODE2			
No	Record ID	Type	Length	Status	Description
1	CODE1 (For FR/DP mapping CODE1: CODE in FR table + PARENT in FR table + NUMBER in FR table)	String	10	PK1	Identify the domain description
2	CODE2 (For FR/DP mapping CODE2: CODE in CONSTRAINT table + PARENT in CONSTRAINT table + NUMBER in CONSTRAINT table + DOMAIN in CONSTRAINT table)	String	20	PK2	Indicate the zigzagging source

Table 12 - Detailed information for EFFECT table

Table ID		DM (Relate between FR and DP (FR/DP mapping))			
Unique Index		CODE1 + CODE2			
No	Record ID	Type	Length	Status	Description
1	CODE1	String	10	PK1	Identify the row for design matrix element
2	CODE2 (For FR/DP mapping CODE2: CODE in DP table + PARENT in DP table + NUMBER in DP table + ALTERNATIVE in DP table)	String	10	PK2	Identify the column for design matrix element
3	VALUE	String	40		Represent the effect between FR/DP
4	COMMENT	String	300		Represent the comment for the element

Table 13 - Detailed information for DM table

Table ID		Identify specific operation (i.e. method in the source file)			
Unique Index		NAME + ATTRIBUTE			
No	Record ID	Type	Length	Status	Description
1	NAME	String	10	PK1	Identify the source code
2	METHOD	String	20	PK2	Indicate operation within the source code
3	DESCRIPTION	String	80		Represent the description

Table 14 - Detailed information for OPERATION table

Table ID		Identify specific variable (i.e. attribute in the source file)			
Unique Index		NAME + METHOD			
No	Record ID	Type	Length	Status	Description
1	NAME	String	10	PK1	Identify the source code
2	ATTRIBUTE	String	20	PK2	Indicate data within the source code
3	DESCRIPTION	String	80		Represent the description

5

Table 15 - Detailed information for VARIABLE table

Table ID		Relate between VARIABLE and DP			
Unique Index		NAME + ATTRIBUTE + CODE2			
No	Record ID	Type	Length	Status	Description
1	NAME	String	10	PK1	Identify the source code
2	ATTRIBUTE	String	20	PK2	Indicate data within the source code
2	CODE2	String	10	PK3	Identify the column for design matrix element

Table 16 - Detailed information for ATTRIBUTE table

10

Table ID		Relate between OPERATION and DM			
Unique Index		NAME + METHOD + CODE1 + CODE2			
No	Record ID	Type	Length	Status	Description
1	NAME	String	10	PK1	Identify the source code
2	METHOD	String	20	PK2	Indicate operation within the source code
3	CODE1	String	10	PK3	Identify the row for design matrix element
4	CODE2	String	10	PK4	Identify the column for design matrix element

Table 17 - Detailed information for METHOD table

Realization of a Software Design Database

A) Database Construction

To access a design database system, the structure for the design database may be pre-defined within the database system, and the users to access the database must be assigned properly. A database manager usually performs these steps at the beginning of the database design. However, a software production system may generate the database structure and assign users automatically. If a commercial database system (e.g. Microsoft Access, Oracle, DB2 and the like) supporting the Structured Query Language (SQL), the database system can create the database structure supporting software design. SQL has several command syntaxes to contact the database. Examples for these SQL commands include:

- Table Creation

```

create table table_name (record_name_1, record_type(record_length),
recore_name_2, record_type(record_length),
...
recore_name_n, record_type(record_length));

```

- User Creation

```
create user user_name identified by password;
```

B) Data Handling

SQL has several commands to access a database. These commands are summarized as:

- INSERT: Stores a new data set
- UPDATE: Modifies an existing data set
- DELETE: Erases an existing data set
- FETCH: Inquires the data set which matches the given condition

A software designer can manipulate the design database using these commands and the software system may provide standard interfaces between designers and the software database.

Database Implementation

A database implementation is shown in Figure 21. Whenever the user provides a query, the database system searches the design database and determines matched

information based on the provided query. If the database system can determine the required DP information, it will provide the result(s) within a scrollable list table as shown. Therefore, the user can navigate the suggested search result to determine a proper DP to use. If he/she decides to select one of the suggestions, the database system adds the selected design hierarchy into the current design specification. In this way, the software designer may improve the reusability, reduce maintenance cost and reduce the development cost of software. Detailed actions performed by the database according to various embodiments of the invention are as follows:

A) Query

According to one embodiment of the invention, the database system includes a graphical user interface that allows a user to search through the software design database. The interface has several fields listed below:

- Input: search string
- Options:
 - For multiple string search:
 - ✓ AND: find data which includes all the search string
 - ✓ OR: find data which includes at least one search string
 - For domain:
 - ✓ FR: find DP data with corresponds FR information
 - ✓ DP: find DP data directly
 - ✓ DM: find DP data which has the same string within the design matrix
 - ✓ All: find DP data with all cases listed above
 - For layer:
 - ✓ Package: find DP data located at the higher level in the design hierarchy (in case of the designer wants to get the whole packages which include several class files)
 - ✓ Class: find DP data located at the middle level in the design hierarchy (in case of the designer wants to get a specific class files)
 - ✓ Method: find DP data located at the lower level in the design hierarchy (in case of the designer wants to obtain the detailed methods which includes specific algorithms)
 - For field:

- ✓ description: find the search string in description field
- ✓ keyword: find the search string in keyword field
- ✓ comment: find the search string in comment field
- ✓ category: find the search string in category field
- 5 ✓ all: find the search string in all field

B) Search Result

As a user selects one of the search results, a user can access detailed information so that he/she can obtain more information regarding how the design works. During this navigation process, the user can decide which suggested design fits into their design. To provide the proper information, the database system provides information to the user in three different formats such as:

- Hierarchy and descriptions for each level including FR/DP/PV and design matrix
- Graphical representation with UML (discussed below in more detail)
- 15 • Source code view

C) Confirmation of Design Selection

After the user makes a decision to use one of the design suggestions, the database system copies information associated with the design suggestion from the selected design and pastes into the current design. According to one embodiment, the database system may provide several guides to allow minor changes to fit into their design requirements.

Automatic Generation of Unified Modeling Language (UML)

According to one aspect of the invention, the software design system generates Unified Modeling Language diagrams based upon the axiomatic design. In particular, the software design system may perform the following:

- Represent the UML using axiomatic design terminology such as FRs, DPs and design matrix
- Draw UML diagrams directly
- Generate data file to feed existing software (e.g. Rational Rose)

30 In the 1980s and early 1990s, object-oriented method was the fashionable technology which was going to solve the software crisis [R.S. Pressman, Software Engineering, A Practitioner's Approach, 4th ed., New York: McGraw Hill, 1997]. There

are several approaches have been introduced for the object-oriented method and three major authors (Rumbaugh, Booch and Jacobson) were spotlighted among these approaches. Recently, all these authors are agreed to combine their approaches and come up with a standard framework. As a result, the UML (Unified Modeling

5 Language) has become a standard to develop object-oriented software programs [Rob Pooley and Perdita Stevens, Using UML – Software Engineering with Objects and Components, Addison-Wesley Longman, Inc., 1999][Martin Fowler and Kendall Cott, UML Distilled, Addison-Wesley Longman, Inc., 1999][Hans-Erik Eriksson and Magnus Penker, UML Toolkit, John Wiley & Sons, Inc. 1998]. UML is a visual language to

10 represent the information in the models with graphical symbols and connections. Therefore, UML facilitates communication between project managers, programmers and designers by identifying complex relationships in object-oriented systems. Although UML represents software systems with standard symbols, the software design itself (the actual coding) remains for the designer's to complete.

15 Axiomatic design is useful design theory for the software design. Although most axiomatic design research is focused on mechanical systems, axiomatic design may be used to develop a software system and also support automatic code generation to assist the designer. Applying axiomatic design principles to object-oriented programming, and more specifically providing a system and method for generating UML diagrams provides

20 the following advantages:

- **Reduces Modeling Effort:** There are several commercially-available software packages provided to support creating system designs in UML. Each software package has their own interface to generate the UML, and in general, these packages function similar to a drawing editor. Users work within these interfaces interactively

25 to design software systems. This interactive work often produces poor designs because design is trivialized by a drawing program--the required thought or time is not invested in design of the system. Further, UML and their editing programs alone do not provide criterion by which a design may be evaluated. By contrast, by implementing axiomatic design principles to design software, interactiveness

30 between software modules may be reduced and quality of the software guaranteed if the design satisfies particular design axioms.

- **Maintain consistency:** UML creation from axiomatic design provides a same interpretation between the two concepts. First, it provides a consistent viewpoint for

the design (the result of axiomatic design), design representation (the UML) and the real source code. Second, this consistency helps the collaborative design and development environment for the software system.

5 **Introduction**

In this section, a relation between UML and axiomatic design according to one embodiment of the invention is presented. A key concept in UML is relationships between object-oriented classes. All representation in UML (for example, sequence diagram, activity diagram, and the like) is based on these relationships. This relationship concept is strongly matched with the design matrix in axiomatic design. Therefore, according to one embodiment of the invention, the design matrix information is expanded into a mapping result between domains.

Use Case Diagram

15 **Definition:** A use case is a description of how a system can be used (from an external actor's point of view). Use cases show the functionality of a system, and are described in terms of external actors, use cases, and the system being modeled. A use case should yield an observable result of value to a particular actor. A use-case diagram contains model elements for the system, the actors, and the use cases, and shows the
20 different relationships such as generalization, association, and dependency between these elements.

Traditional software design methodologies including object-orientated methods usually define ambiguous functional requirements. Although a designer generally thinks about functionality during the design process, traditional design methods generally do
25 not address functional requirements in any concrete detail. Further, there is another aspect to consider regarding the software design. The following question might be helpful to understand this aspect. "How does the designer define the functionality or functional requirement?" A customer's point of view is one of the required information to give an answer for this question. However, the information provided by the customer
30 is also buried inside the software design as well. The use case diagram is therefore introduced to explain this customer's viewpoint.

Use cases were first introduced by Ivar Jacobson in the early 1990s, as development from the earlier idea of scenarios. Use cases represent the functionality of a

system from a user's point of view by definition. The "user" means anything external to the system being developed which interacts with the system. A user might be a person, another information system, a hardware device, etc.

Axiomatic design provides a domain concept to explain the "what" and "how" relation between domains. For example, the mapping between customer domain and functional domain interprets the customer needs into functional requirements. Therefore, the customer needs in the customer domain is an excellent concept that may be used to represent the use case of a software system. Also, customer needs can have hierarchies like FRs and DPs. Because methods for constructing customer needs are various, customer needs having multiple hierarchies may be used to describe them.

For example, three major hierarchy levels for software systems are used to fit into the use case concept. The first layer, called as actor layer, represents actors and can have multiple actors to represent different actor's viewpoint or relationship between actors. This layer may or may not have lower levels. The second layer describes customer needs that belongs to the actor's viewpoint and are referred to as the use case layer. This use case layer may or may not have lower levels to represent more detailed explanation. The third layer, referred to as a relation layer, describes the relationship between the customer needs in an intermediate layer. Figure 22 shows a modified version of customer needs according to one embodiment of the invention, and is a use case diagram based on the customer needs hierarchy.

Example

To provide a better understanding of the functional concepts, a simple drawing example is provided below, the simple drawing example being an extended version of the simple drawing example explained above:

- Customer needs:
 - ✓ Actor layer:
 - CN1: User
 - ✓ Use case layer:
 - CN11: We need a software to draw a line or a rectangle or a circle at a time.
 - CN12: The software should work with mouse using push, drag, and release.
- Use case diagram (as shown in Figure 24):
- Top level design:

	DP1: Element characteristics	DP2: GUI with window
FR1: Define element	A	0
FR2: Specify drawing environment	a	B

- Second level for FR1

	DP11: Line characteristic	DP12: Rectangle characteristic	DP13: Circle characteristic
FR11: Define line element	C	0	0
FR12: Define rectangle element	0	D	0
FR13: Define circle element	0	0	E

5

- Second level for FR2

	DP21: Radio buttons	DP22: Mouse click information	DP23: Drawing area (ie. Canvas)
FR21: Identify the drawing type	F	0	0
FR22: Detect drawing location	b	G	0
FR23: Draw the element	c	0	H

- Third level for FR11:

	DP111: Start point	DP112: End point
FR111: Define start	I	0
FR112: Define end	0	J

10

- Third level for FR12:

	DP121: Upper left point	DP122: Lower right point
FR121: Define upper left corner	K	0
FR122: Define lower right corner	0	L

15

- Third level for FR13:

	DP131: Center point	DP132: radius
FR131: Define center	M	0
FR132: Define radius	0	N

- Third level for FR21:

	DP211: Line button	DP212: Rectangle button	DP213: Circle button
FR211: Identify line	O	0	0
FR212: Identify rectangle	0	P	0
FR213: Identify circle	0	0	Q

20

- Third level for FR22:

	DP221: Event for push	DP222: Event for release
FR221: Detect mouse push	R	0
FR222: Detect mouse release	0	S

- Design hierarchy (as shown in Figure 25):
- 5 • Full design matrix (as shown in Figure 26):

Class

Definition: A class is a model element used to model entities, both intellectual
 10 and physical. A class is described with numbers that are attributes, operations, and
 relationships to other classes. The members are reflected in objects of the class. A class
 can be generalized and specialized; extension mechanisms may be attached to the class.

A class may have several behaviors for different activities and these behaviors
 usually are represented by one or more methods which actually manipulate the data (i.e.
 15 attributes) inside the class. This set of information can be represented by FRs, DPs and a
 design matrix and called as an object having indices. The behaviors should be located at
 the bottom of design hierarchy (i.e. leaf) because the behavior defines activity for a class.
 Therefore, at least one or two higher level FR/DP relations in the design hierarchy should
 be indicated as a class. Occasionally, an attribute inside a class is an instance of another
 20 class that indicates a part or an inner class. Figure 25 illustrates the basis of class
 representation for the design hierarchy.

Based on the domain specification for the software design, the process domain
 represented by process variables (PVs) may define the specification for the source code.
 For example, the specification can be a package name, class name, method name, and the
 25 like. According to one embodiment of the invention, the design matrix relating DPs and
 PVs is always the same as FR and DP because the PV determines source code, and all
 the information within the source code are provided by the FR/DP relation. In this way,
 communication between the designer and the programmer can be guaranteed and
 maintained consistently. Therefore, these kinds of design decisions can be completed
 30 with this mapping.

Zigzagging between the two domains (i.e. physical domain and process domain)
 can be performed whenever the designer chooses. For example, zigzagging may be
 performed after the FR/DP mapping is finished at any level in the design hierarchy.

However, it is preferred that zigzagging is performed after the whole FR/DP mapping completes because the designer should think about the size of the entire software and number of class files. Further, it may be difficult to define the class specification during the design decomposition. Once one of the intermediate levels is determined as a class
5 by a designer, further decomposition may not be necessary because the detailed design specifications such as attributes and methods are at a lower level in the FR/DP domain. Due to the limitation for the decomposition process which only focuses on the diagonal elements in the design matrix, Figure 28 shows the class definition for the diagonal design matrix element in the example described above.

10 The final step is to define all the other classes (i.e. the off-diagonal design elements). The most common way to define the off-diagonal classes is to follow the class definition in the process domain. However, designers can categorize the off-diagonal terms in design matrix in their own way. Using the former definition, the example may have one off-diagonal class (i.e. object 1*: FR2-a-DP1). The element b
15 and c in the full design matrix do not require separate classes because these elements are located within the window_d class. Figure 29 shows the detailed method definitions for the design matrix elements and Figure 30 represents the entire class definitions for the given example.

20 **Relationships**

Definition: A relationship is a semantic connection among model elements. A relationship is specialized to generalization, dependency, association, transition, and link.

The relationship can be categorized in two manners. The first is the macroscopic relation which includes generalization, association, aggregation and so on. The second is
25 the microscopic relation to represent the message transfer between classes. In axiomatic design, the macroscopic relationship can be specified at the intermediate or higher level (for instance, class level in the Figure 27) in the design hierarchy. On the other hand, the microscopic relationship is belongs to the leaf or one level above from the leaf level (i.e. object or behavior level in the Figure 27).

30 A method for defining each one of the design matrix elements for the FR/DP domain may be based on the following questions.

- Does changing the DP affect the FR?
- Does the design of the DP affect the way the FR is satisfied?

- Does the choice of this DP affect that FR?
- Can the DP be designed without affecting the FR?

Whenever the designer finishes to fill out the entire design matrix elements and determines the class for the process domain, the following questions can serve as the

5 basis to fill out the design matrix for the DP/PV domain:

- What kind of relation does this element indicate?
- How many multiplicities are involved?
- Does this relation have directions?
- What kind of message should be transferred?

10 To answer these questions, decision making for the design process is performed. Also, it is the modeling process of software engineering. Figure 31 represents these decision making processes for the example and shows that the designer wants to have aggregation relationships in this design.

15 **Class Diagram**

Definition: A class diagram shows a static structure with classes and their definitions and relationships.

As the information for FR/DP design matrix, DP/PV design matrix, and PV class structure is combined, the class diagram can be generated automatically. One of the
20 advantages of class diagram produced from axiomatic design is that the design “makes sense” to the designer, and this is important in terms of design viewpoint. Using the notation with “_d” for diagonal classes and “_*” for off-diagonal classes, the class diagram provides much more clear understanding of the design than that from object-orientated diagrams. Figure 32 shows such a class diagram. The class diagram shown in
25 Figure 32 shows the macroscopic relations of objects generally. The microscopic relation can be shown with further diagrams described below.

Interaction Diagram

Definition: An interaction shows how the class/objects interact to perform a
30 specific functionality. An interaction diagram is a generic term for sequence, and collaboration diagrams.

Interaction diagrams record in detail how objects interact to perform a task. In particular, the interaction diagrams isolate each individual task's behaviors using graphical representation and the interaction diagrams include a set of operations. A task can be represented as a functional requirement of the system. Axiomatic design determines a definition for a module, the definition being a more specific definition than that for the entire software system. The definition describes a particular task represented by the functional requirement. A module is defined mathematically in equation (4) as follows:

$$M_i = \sum_{j=1}^{j=i} \frac{\partial FR_i}{\partial DP_j} \frac{\partial DP_j}{\partial DP_i} \quad (4)$$

Therefore, interaction for a task can be defined as a sum of design matrix elements in a row and its corresponding DPs. The sequence of the interaction progresses from a right to a left direction because an element on a diagonal of the design matrix (referred to as an "on-diagonal" element) serves as the starting point for the corresponding FRs. If the task only has an associated on-diagonal design matrix element, interaction diagram does not need to be generated because there is no interactions with the other tasks. Figure 33 shows the interaction definition for the example described above.

- Collaboration Diagram

Definition: A collaboration describes how a set of objects interacts to perform some specific function. The collaboration diagram also describes both a context and an interaction. In particular, the context shows a set of objects involved in the collaboration along with links to each other. The interaction shows communication performed by objects in the collaboration. A collaboration diagram describes how objects interact, and focuses on the collaboration in space, which means that the relationships (links) between the objects are explicitly shown.

With the definition of interaction, the collaboration diagram can be shown using FRs, DPs, and a design matrix. Figure 34 illustrates the collaboration diagram based on Figure 33 for task FR23.

- **Sequence Diagram**

Definition: A sequence diagram describes how objects interact with each other. Sequence diagrams focus on time, meaning they display when messages are sent and received.

5 A sequence diagram may be shown with the definition of interaction. Figure 35 shows one embodiment of a sequence diagram based on Figure 33 for task FR23 in the example described above.

 If these diagrams are too complicated, a designer can decompose these further. Therefore, these interaction diagrams can serve as a guide to further decomposition. For
10 example, FR23 can be decomposed into FR231: Draw a line, FR232: Draw a rectangle, and FR233: Draw a circle. Thus, the collaboration diagram and sequence diagram is more concise (e.g. if a designer needs to see the interaction for “FR231: draw a line”, the collaboration diagram and sequence diagram only shows the interaction with 1, 1.1, and 1.1.1 from the Figure 34 and 35).

15

State Diagram

Definition: An object state is determined by its attribute values and links to other objects. A state is a result of previous activities in the object. A state diagram captures object life cycles (also the life cycles of subsystems and systems). The state diagram
20 illustrates how events (messages, time, errors, and state) changes affect object states over time.

 Information for object state changes may not be identifiable using axiomatic design. It needs another definition to represent correctly and the definition is not fixed in axiomatic design so far. Even though the state diagram is useful to understand the
25 operation of the system, this diagram is not necessary often during the software development process.

Activity Diagram

Definition: An activity diagram shows interactions between entities, focusing on
30 the work performed. The activity diagram displays a sequence of actions including alternative executions and objects involved in performing the work.

 Activity diagrams record the dependencies between activities, such as which activities can occur in parallel and what activities must be completed before one or more

other activities can start. In axiomatic design, these kinds of information can be represented by the design matrix. For instance, if a design is uncoupled, it can be represented with any kind of sequence (i.e., parallel activity) and if a design is decoupled, there is at least one sequence to follow. As a result, the flow chart (i.e.,
5 system architecture) is an excellent representation that may be used to show activities for the software system. A translation between flowchart and activity diagrams may be easily performed. In particular, the summation can be represented as synchronization bar and all the other activities can be connected with arrows. Figures 36 and 37 show one such translation.

10

Component diagram

Definition: A component diagram describes software components (source, link, and executable) and their dependencies to each other, and represents the structure of the code. The components are distributed to nodes in a deployment diagram described
15 below.

A component defined in UML means ‘a distributable piece of implementation of a system, including software code (source, binary or executable) but also including business documents, etc., in a human system [UML Notation Guide version 1.1, OMG ad/97-08-05 1997]. If the software system integrates with other hardware system or
20 other different packages, the component diagram can be used to understand overall interfaces. Figure 38 shows a component concept developed from axiomatic design elements.

Deployment Diagram

Definition: A deployment diagram shows the run-time architecture of processors, devices, and the software components that execute in the architecture. The deployment diagram is the ultimate physical description of the system topology, including the structure of hardware units of the system and the software that executes on each unit.

The deployment diagram is an extended version of the component diagram.
30 Therefore, representation of the deployment diagram using the axiomatic design result is possible also.

UML Script Code Generation

There are several methods to generate UML with axiomatic design. One method is to generate the required diagrams directly. The other is to generate a model data file which serves as an input data file for existing UML software packages such as Rational Rose design system. Further, according to another embodiment of the invention, the axiomatic design system may directly generate UML code. UML code is represented by script type formats defined by the document entitled OMG Unified Modeling Language Specifications, version 1-3, June 1999 (available at <http://www.rational.com/uml/resources/documentation/index.jtmpl>). Based on the UML documents described above and the UML specifications, the axiomatic design system can generate this UML script code. Further, Rational Rose design software also uses this script code format for their input/output data file. Therefore, the UML script code generation can be synchronized between the axiomatic design systems of the present invention and other design packages such as Rational Rose software. Figure 39 shows an example of UML script code.

Automatic Code Generation

As discussed above, axiomatic design principles may be incorporated into a software design that, upon instruction of a user, creates software systems. According to one aspect of the invention, the software system automatically generates code based upon an axiomatic design. According to various embodiments of the invention, the software design may have one or more of the following properties:

- In accordance with one embodiment, a system is provided that generates code skeletons in a target language and transfers the information from the axiomatic design into code in that language.
- In accordance with one embodiment, a system and method produces code skeletons using axiomatic design terminology such as FRs, DPs and design matrix.

Writing down source code is one of the major items to be performed in the software development life cycle. This coding process is generally performed by a head programmer based on the modeling information which is the result of prior process. To reduce maintenance efforts, it is highly recommended to add a lot of comments, which describes modeling information, inside the source code between line by line or method

by method. However, most programmers feel this work is cumbersome or time consuming. Generally, the code is further developed, less comments are inserted into the code due to apathy, increased familiarity with the code (by the programmers), or by rushed development during later stages. According to one aspect of the invention, information produced by the design process may be automatically translated into comments in the code. More specifically, as a designer proceeds through the axiomatic design, the designer produces rich information including data structure, function structure, relationships, and so forth. According to various embodiments of the invention, a software design system may be provided that performs one of more of the following:

- Generate the entire source code skeletons using these rich information.
- Reduce the coding time by automatically generating code and comments.
- Provide consistency between design and source code.

Further, various embodiments of the invention provide one or more of the following advantages:

- **Reduce the coding effort:** Automatic code skeleton generation provides more time to focus on algorithm development. It also provides a clear outline and instruction to assist the programmer in developing specific methods inside the code skeleton because the code skeleton reveals design comments such as design descriptions and comments associated with the design description.
- **Maintain consistency:** The code skeleton can act as a bridge between the design and the actual source code by using the same description in software design. In one case, the programmer may use specific code generated by the design specification.

Alternatively, the programmer might have the design information for the method that he/she is trying to make. Either way, the design process concludes with the actual code.

Several commercially-available software products have features to generate code skeletons. Some of these products use UML, especially class diagrams. Code skeletons produced by these products generally include class name, attributes, methods and brief comments. However, according to one embodiment of the invention, results of the axiomatic design process are used to generate code skeletons and comments.

Because the axiomatic design process requires detailed information, the code skeleton generated can have much more detailed descriptions than that which are traditionally provided by UML. It consists of class name, attributes, methods, detailed comments and the sequences to finish the actual algorithm.

5

Introduction

A code generation scheme according to one embodiment of the invention is disclosed below. To provide a better understanding, the following is based upon simple drawing example described above with respect to Figures 24-26.

10

Data structures for code generation

The data structures used for code generation may be identical with the definitions described in the line drawing example above. Each one of the attributes inside the ER diagram represented in Figure 20 is the inputs for code skeleton. The specific examples for these inputs are described in Figures 2 through 26 based on the line drawing example described above.

Figure 40 shows a DP table based upon the line drawing example described above. Figure 41 shows a DP/VARIABLE table and ATTRIBUTES relating the DP and VARIABLE tables for the example. Figure 42 shows a table relating a DM table to an OPERATION table through a METHOD table. It should be understood that these tables are merely examples of a system design upon which code may be generated, and that other system designs may be used.

Code skeleton

Every object-oriented programming language has similar structure such as class name, global attributes, a constructor and methods. The comments generally may be located anywhere inside the code. Therefore, a code skeleton that follows language structure and provides a clear, well documented structure may be used.

Figure 43 shows a standard code skeleton generated according to one embodiment of the invention. In particular, Figure 43 shows the process by which code is produced. In an "Introduction" area, comments for the classes may be inserted. Alternatively, comments may appear in various sections of the code. These comments may include, for example, descriptions of the FRs, DPs or any other information

describing the code file or design. In “Define import package” area, other code to be included in a compilation of the code may be referenced. In a “Define class” area, packages and class types may be defined. Attribute types corresponding to the design may be commented on and defined in a “Define global attributes” area. In a “Define constructor” area, comments and constructors for the objects corresponding to the design are defined. Further, in a “Define methods” area, methods associated with objects of the design are defined. Within this “Define methods” area, coding sequences that reflect any interactions prescribed by off-diagonal elements of the design matrix are placed. In a “Define finish” area, proper end statements are placed according to programming language conventions.

Figure 44 shows an example code skeleton written in the Java programming language produced using the code skeleton and method described above with respect to Figure 43. In particular, Figure 44 shows a Java code skeleton based upon the line drawing example described above, for $FR2 = a*DP1 + B*DP2$. Of course, sections of the code are determined according to programming language conventions.

Because a code skeleton is produced that follows language conventions, provides a clear document structure, the programmer can spend more time to focus on the algorithmic viewpoint with this consistent code skeleton. One or more of the following may be included in a code skeleton in accordance with various embodiments of the invention:

- Axiomatic design description: information that is collected about the design
- Roadmap: strategy for recognizing the current activity being performed by the designers and relating this to the overall progress of the design
- Guidance: suggestions or questions-for-thought to assist the designers
- User interface: the layout and operation of the graphical user interface
- Options: the variety of choices for customizing the software
- Algorithms: the details of how a function or calculation is performed

User Interface

As discussed previously, design tasks can be represented as a mapping between domains. Designers map from requirements of what they want the design to do to solutions of how the design will achieve these requirements. As the design progresses, broad, high-level requirements are broken down, or decomposed, into smaller sub-

requirements which are then satisfied by sub-solutions. As the designers select solutions, they use the two design axioms to evaluate whether the design is a quality design.

The benefits of a software tool for applying axiomatic design, as embodied in design software implementing axiomatic design principles, are many:

- 5 1. Designers can start with ill-defined customer needs and use the design software to document and organize these needs.
2. As designers develop concepts, they define requirements, develop additional concepts, and select solutions using the design software. The design software provides one or more of the following:
 - 10 (a). The design software captures the history of the project and the rationale for the decisions that were made.
 - (b). An archive of solutions can be used to build a corporate knowledgebase and to transfer learning between parts of the organization.
 - (c). Different solution alternatives can be evaluated and compared objectively.
- 15 3. The design software provides tools for systems engineering that capture and use the hierarchy of design information that naturally grows as the design progresses. The design software provides one or more of:
 - (a). The design software captures constraints and their application throughout the design.
 - 20 (b). The design software lets managers check consistency between multiple sub-tasks.
 - (c). As changes are considered or made during the design, the design software tracks the interrelationships between parts of the design to determine what else in the design is potentially affected.
- 25 4. The design software provides tools for project management.
 - (a). The design software lets designers and managers assign resources (time, budget, and responsibility) to the project and to distribute them among the design tasks.
 - (b). The design software tracks the use of the resources as the design progresses.
5. The design software enables robust design.
 - 30 (a). Tolerance design can be done in the design software. The designers can assign tolerances to components of the design to achieve the required functionality.

(b). Data about as-produced variation in components can be used in conjunction with tolerances and desired functionality to calculate probability of success as described in axiomatic design using information content.

The design software using axiomatic design principles provides benefits for the company, managers, and designers. For the company, the design software provides greater profit, a competitive advantage over companies who do not use such design principles, and less risk in developing software. For the manager it provides effective resource assignment, effective change management, and institutional learning and knowledge transfer. For the designer, it provides focused creativity, better designs, and quick design completion.

- **Automate the design process:** Designers follow several steps to design using axiomatic design. Programmers commonly refer to these systematic processes as a “roadmap” [Derrick Tate, “A roadmap for decomposition: Activities, Theories, and Tools for System Design,” Ph.D. thesis, department of Mechanical Engineering, MIT, Cambridge, MA, 1999]. The user interface of the software system according to various embodiments of the invention may be designed based upon these steps. Whenever a designer enters FR data into axiomatic design software, it queries for the corresponding DP information and manages the size of design matrix, design hierarchy automatically. Also, the axiomatic design system displays the next step to follow by checking the current status. This automation scheme assists users to follow the axiomatic design process.
- **Spread axiomatic design concepts among the programmers:** To shift the design paradigm requires great effort because most programmers usually do not want to change from what they have learned to a new programming concept. There are several approaches to overcome this difficulty. One of the most effective ways is to use software which visualizes the overall system development concept.
- **Forces programmers to focus on the design:** Design is a creative work which is performed by human thinking. The real power from axiomatic design concept is to allow the designer to think about their problem using a systematic approach. Design software according to various embodiments of the invention provide this thinking environment by asking several questions of the programmer in a step by step manner. These questions force designers to focus on their design so that they have more chance to create quality software.

- **Manage changes:** As discussed, it is difficult to keep track of software changes manually. According to various aspects of the invention, a design software system is provided that manages the changes during the design process automatically.
- **Document the design with various formats:** Designers might need several formats to explain their design. Even though the design data is the same, work needed to make the design document requires large amount of time if the designers need several different formats. This duplication activity can be enhanced with the software. Design software according to one embodiment provides several different data formats through which the designer may visualize the designed result in the form of printed documents, graphics images to be copied into different applications electronically and data file that feeds into other application programs. The system manipulates the same design data set and produces the required design document according to the needs of the designer.

15 User Interface

To provide better understanding of various user interfaces according to various embodiments of the invention, the following description is provided with respect to Figures 45-80

1. Tables

- **Explain the domain mapping with table format:** Axiomatic design forces users to maintain one-to-one mapping between domains. It is an intuitive user interface to have a table having several columns which represent each domain and rows for one to one mapping. This table interface covers the mapping between FR and DP or DP and PV and is shown in Figures 45A and 45B as alternative embodiments of such an interface.
- **Merged FR cell to explain the alternative choices for DPs:** Designers usually think of several choices to satisfy a specific FR. These choices can be explained as alternatives. Seeing all the possible choices at once with corresponding FR provides more useful environment for a designer. Figures 46A and 46B show several embodiments of an interface showing alternative design choices to a designer.

- 5 • **Display parent FR/DP information:** To allow a designer to visually determine the parent FR/DP information during the decomposition provides a designer a greater change to create accurate sub-level FR/DP pairs and reduces the step for parent level inquiry. Figures 47A and 47B show several embodiments of an interface presenting such parent FR/DP information.

- 10 • **Display the parent node number with abbreviation:** Using an abbreviation for parent number provides a simple interface and increases the space for data entry. Such an interface is shown in Figures 48A and 48B.

- 15 • **FR/Constraint mapping:** Unlike a mapping between two different domains, the constraint determines boundaries for FRs. However, the one-to-one mapping is not valid for FR/Constraint relationships. Thus, it is more intuitive to show these FR/Constraint relations in a table. Figures 49A and 49B show various embodiments of an interface presenting FR/Constraint relationship information.

- 20 • **CN/FR mapping:** The relation between FRs and CNs are usually vague. The CN explains broad needs and specific needs all together and can include multiple requirements within a sentence in most cases. Because of these characteristics, presenting a one-to-one mapping with FR is not possible. The interface shown in Figure 50 displays mappings between CNs and FRs to the designer. According to one embodiment, this interface uses tables and tree displays and indicates as a check box for the mapping. Alternatively, the interface uses the same table format as that of the design matrix. For example, CNs are displayed in a first column and FRs are displayed in a first row of the table. Further, the interface may display multiple CN lists which are satisfied by a specific FR. It should be appreciated that any method for displaying CN and FR information may be used.

- 25 • **Budgeting for constraints:** Some constraints are limited by certain parameter values. For instance, weight, cost and volume are constraints restricted by the target market, manufacturing environment and so on in mechanical systems. These constraints usually have operators such as less than, more than, equal to, etc. Design

- 30

software according to one embodiment of the invention captures this information and allows the designer to compare the designed constraint and the real value of their product when the design is complete. Figure 51 shows one such graphical representation.

5

- **Add additional column to display detailed information:** It is also useful to display additional information to a designer such as comments, keywords, application links, etc. within the same table. Figures 52A-C show various embodiments of interfaces displaying detailed design information.

10

- **Nested (or full) design matrix table:** In order to have more accurate design, designer should check the consistencies between levels in the design hierarchy. The nested design matrix table shown in Figure 53 is a useful interface that allows a designer to check the relationships between different levels.

15

2. Layouts

- **Display the mapping and relationship at the same time:** The layouts shown in Figures 54A-C reduces steps needed by a designer to compare the FR/DP information.
- **Display the sequence of design activity:** As discussed above, there is a sequence to design software systems using axiomatic design principles. This roadmap sequence can be grouped as four different activities. In particular, a tabbed interface may be used to indicate these groups and control the tabs depending on the design situation. Examples of these tabbed interfaces are shown in Figures 55A-55B.

2.1 Components for design guide.

- **Design question area:** One of the best methods for implementing an axiomatic design is to prompt the designer with questions regarding the design at each step, because the axiomatic representation describes the thinking process systematically. Figure 56 shows an interface that presents components that support a visualization of the human thinking process.

30

- **To do list area:** The design software provides several lists to be checked based on the design roadmap.
- **Legend indication area:** Several conditions such as design status, alternative/redundant DPs, and the like are indicated to provide clear information.
- 5 • **Aerial view area:** In the case of a large designs, it is useful to indicate a focused location of the design by showing an overall picture of the entire hierarchy displaying nodes as small boxes.
- **Scrolling theorems, corollaries linked to active tab:** Theorems and corollaries may be added to refine several cases. They can be categorized depending on the design
10 activity. A scrolling component may be included that reminds the user of the rules of axiomatic design.

“How to” combo box: Interfaces such as context-sensitive help allow users to obtain help regarding the use of a software system. an example of such a question is “How can I do something that I want with this tool?” FAQ (Frequently Asked Questions) lists and
15 tutorials are typical kinds of solutions that satisfy this requirement. The design software may include a component to provide a proper answer for this question. We have a bunch of resources from our customer in terms of these questions.

3. Buttons / Menus / Icons

- 20 • **Database I/O toggle menu in File menu:** A software design system may include two different data store mechanisms. One may be file I/O for all users (i.e. single and/or multi-user). The other may be the database I/O only for multi-user design cases. To indicate these two different storage functions, a software design system may include a toggle menu. Once the user toggles on this menu, the entire data is
25 sent to the database. Otherwise, the data is stored as a separate text file. As a result, the database function is user-friendly and steps required to be executed by a user in the storing process is minimized. Figure 57 shows an embodiment of an interface having such a toggle control.
- 30 • **Alternative DP toggle button in the FR/DP or DP/PV handling window:** To reduce steps to add design data, an automation scheme may be provided to add alternative data. The alternative DP is usually entered upon the user’s request. Once

the user toggles on an Alternative DP button as shown in the interface of Figure 58, the system automatically adds one more blank row for the alternative DP based on the automation scheme. Thus, the system reduces data adding steps.

- 5 • **One step design matrix control buttons:** To populate the design matrix with data generally requires iterative work by the designer. To reduce this iteration, the design software may include a set of controls that when activated, the system fills out the design matrix with specific patterns. For example, these controls may include:
- 10 - **Radio buttons for current choice:** The design matrix element is filled out with a toggled item defined by a user.
 - **Make diagonal button:** Activation of this button makes the design matrix a diagonal matrix automatically.
 - **Make triangular button:** Activation of this button makes the design matrix a triangular matrix automatically.
 - 15 - **Set button:** Activation of this button fills the design matrix with a choice of radio button for the current selection. If a user selects multiple cells, the system fills out those selected cells. Otherwise, the system fills out every undefined design matrix cell. These controls are shown in more detail in Figure 59.

20 4. Automation

- 25 • **Automatic menu/tab/button control to represent the roadmap:** Optimally, a designer should follow several steps in order to apply axiomatic design principals. These steps can be represented in the software with conditional checks. The table displayed in Figure 60 explains how menus, tabs, and buttons may be controlled by the roadmap.
- 30 • **Automatic blank row display to prepare data entry:** Design software according to one embodiment of the invention may include add buttons to enter the data such as CN, FR, DP, Constraints, and the like. Whenever a user pushes an add button, a separate dialog box pops up for data input. Alternatively, the system use a Microsoft Excel-type table-handling scheme for data entry and may automate this procedure by adding a blank row under the data input table automatically as shown in Figure 61. Also, there may be an option to add a row for alternative DPs as well.

- **Live resizing the design matrix:** The size of the design matrix is highly correlated with the number of FRs and DPs. According to one embodiment of the invention, the design software controls the size of design matrix automatically based on the number of FRs and DPs as shown in Figure 62.
- **Automatic numbering control:** Because of the design hierarchy, axiomatic design uses numbers to indicate different nodes, levels and so forth. According to one embodiment of the invention, the design software controls this numbering scheme automatically. In particular, the software controls the numbers when a user adds / deletes specific data. Also, the software rennumbers all the child level numbers when the user changes a node location.

5. Navigation

15

- **Navigate with design tree:** To navigate within the design hierarchy, the design software may use the design tree (i.e. CN tree, FR tree). When a user clicks one of the nodes in the design hierarchy tree, focused node information is displayed in an associated table area as shown in Figure 63A. The system may also include a DP tree, PV tree for navigation in the same manner.
- **Highlight the focused node in the design tree:** It may be useful to highlight focused node information in the design tree as shown in Figure 63B. This highlighting feature provides visual feeling to the user of where the focus is located.
- **One step Navigation between adjacent level:** The design software system may include a navigation feature between adjacent levels of the design hierarchy as shown in Figure 64. Users can compare the differences between parent and child easily using this navigation feature.

30

Options Adjustment

- 5 • **Display Configuration Control/Management by level adjustment:** Like other design methodologies, a designer, who is trying to use the axiomatic design concept, needs preliminary training. There are several steps to learn the axiomatic design concept. Most of these learning processes were done conveniently in the form of lectures in universities and companies. However, if a software tool supports or represents these learning steps precisely, it is going to be a huge benefit. Therefore, the design software may be adjusted in terms of the user experience level, which represents the knowledge level for the axiomatic design methodology. The table shown in Figure 65 shows how the design software may configure the user interface for a specific user experience level. The black dot means available features for specific levels. The gray dot means enabled graphical interfaces for corresponding levels. Also, users are allowed to turn on and off certain features within the level so that they can customize the software for their own environment.
- 10 • **Numbering Scheme:** This option allows setup numbers for the nodes and hierarchies by user. The table shown in Figure 66 shows one of a possible set of numbers.
- 15 • **Design Matrix setup:** The elements of the design matrix usually include two items. An 'X' means there is a relation between FR and DP and an 'O' item means not. Some designers may want to adjust these elements more precisely. Therefore, the design software may provide freedom to the user to specify alternate design matrix elements as shown in Figure 67. This adjustment may be reflected in the graphical interface as shown. There is also a concept dealing with the measure of coupling in a system [Nam P. Suh, The Principle of Design, 1990, Chapter 4]. The reangularity and semangularity shows the degree of coupling of the design.
- 20 • **Legend setting:** It is important to distinguish among different types of information. The purpose of legends is to visualize the differences between data types immediately. In one embodiment, the design software uses color coding for the legends (not shown). Color-coding is also useful for graphics. As shown in Figure 25 68, an interface through which the user may adjust the legend is shown.
- 30

- **Application Links (or File Location):** According to one embodiment of the invention, the design software is a complementary design tool that integrates with a company's design environment. There are many commercially-available software tools for design (for example, CAD, FEM, QFD, TRIZ and the line. To cooperate with these tools, the design software may include functions to interface with these other software tools. Thus, designers can use their own tools while deploying the axiomatic design concept using application links to the software design system. Acclaro software keeps track the file I/O for the linked applications so that the designer can manage all the information while operating the linked applications.

Information Options Adjustment

- **Real time update for the total number of FR & DP display:** It is useful for a designer to know how large the design in terms of the total number of FRs and DPs; an interface such as that shown in Figure 69 provides such design information.
- **Live question list:** As discussed, axiomatic design is a kind of thinking process. This process can be standardized and represented inside the design software system. In particular, the design software may ask to user a number of questions to guide this thinking process. Examples are discussed below with respect to Figures 70-71.
- **Live to do list:** Designers should check a number of items prior to finishing the design. For example, if they change a specific DP, they have to check the entire downstream impacts to ensure the changes are allowable. Also, if the user did not fill out the required information in the design (i.e. hierarchies), the users may be prompted to finish the insufficient information as shown in Figure 71.
- **Ranking with strong FR-DP association:** A key part of an axiomatic design is the design matrix because it contains a majority of design information. According to one embodiment of the invention, the design software system sets of DPs, distinguishing the best DPs among the alternatives. To suggest the better solution sets, the ranking information should include a set of FRs to be satisfied, design status, number of off-diagonal X's, number of coupled X's and measure of coupling. Designers can

choose a better set of DPs using this information. The strong FR-DP association means that the FRs and corresponding DPs stick together. For example, DP 1 is selected to fulfill the FR 1, DP 2 is for FR 2, and so forth. As shown in Figure 72, FR-DP pairs having strong associations have no alternative DPs.

5

- **Ranking with free association of DPs:** Unlike the strong association, designers might face a situation that they could not specify the DPs for a specific FR although they know the available DPs set and relations with the FRs set. The design software system may search the possible combinations that satisfy the independence axiom to locate the best matching DP.

10

- **Rearrange sequence:** The rearranged information (i.e. design sequences) provide possible combinations to construct the design. For example, if a designer has 5x5 design matrix, the total number of sequence combinations is 5! (=120 cases). However, the possible sequences are restricted by the pattern of design matrix (i.e. uncoupled, decoupled, coupled). According to one embodiment, the design software shows the possible sequences, which are displayed at the lower right side in Figure 72.

15

- **Child list:** Sometimes the child lists for specific nodes are useful to allow a designer to focus on the local problem. According to one embodiment of the invention shown in Figure 73, the design software displays this information rather than using a FR and DP tree window to display the entire hierarchy information.

20

- **Impact list:** If designers wish to change a specific DP, they should check the effect through the hierarchy to make sure the change is allowable. There is a sequence for evaluating this impact effect based on the pattern of the design matrix. To reduce this inspection time, the software design system may display the items to check due to the changes in the form of table and flow chart drawing as shown in Figure 74.

25

30

- **Flow chart display:** The flow chart, which is derived from the design matrix, visualizes the design order with graphics. The design software may calculate this

information with design matrix information and display the flowchart as shown in Figure 75.

- 5 • **Gantt Chart display:** The flow chart can be easily converted into a Gantt Chart, if the time information (i.e. time duration for each module) is provided. According to one embodiment of the invention, the design software has an interface through which a user may enter these time durations and display the corresponding scheduling information visually as shown in Figure 76.

- 10 • **Advice for decoupling:** Axiomatic design software recommends a designer construct an uncoupled or decoupled design. When the designer creates a coupled design, however, there are certain ways to decouple the coupled design. These elements can be summarized as follows:
 - 15 - Check the off-diagonal element in the design matrix and ask if the designer can modify the corresponding DPs.
 - If the designer cannot modify the corresponding DPs, ask for alternatives for the corresponding FRs.
 - Otherwise, provide a suggestion to change the FR which could not be satisfied with the current DP set.

- 20 • **PDF (Probability Density Function) graph display for information axiom:** Information content requires common area that explains overlapped region between system range and design range. According to one embodiment of the invention, the design software shows different distribution types such as uniform, normal,
25 increasing and decreasing. When a designer enters required information to calculate the information content, the system draws the distribution shapes and fill out the common area automatically. Figures 77A-D show different types of PDFs discussed above.

- 30 • **Design documentation:** One of the important features of software design is to document the design results. The system may generate, for example, a design

document having a Hypertext Markup Language (HTML) format as shown in Figure 78. HTML file format is well-known in the art of Internet publishing.

- 5 • **Design tree display for each domain:** Two types of tree contents are available to show CA/FR/DP/PV design trees. One is vertical type and the other is horizontal type. Because both types have advantages, two different types of interfaces may be provided to support users as shown in Figures 79A-B.

- 10 • **One step access for embedded examples:** Simple examples may be embedded in the design software to assist the user. Users can load these examples by selecting one of the menu items under an example main menu, for example.

- 15 • **Drawing transfer using system clipboard:** Some users may want to paste specific drawings, which are generated by the software design system, into their own documents such as journal papers, proposals, reports and so on. The software may include a function to copy the drawings into system clipboards so that users can paste the images into their applications.

- 20 • **Audit:** After a designer has finished the design, they might want to know the completeness of their design. An audit function examines the design and shows if there is missing information. Such an interface that identifies missing information is shown in Figure 80.

Design Matrix Interpretation and Manipulation

25 The design system may include many procedures for manipulating and/or evaluating a design using the design matrix. As discussed, the design matrix includes a great deal of information regarding the system design that may be adapted to provide additional information to a user, for example, such as project organization and system description information including flowcharts, impact lists, Gantt charts, and other
30 information. Algorithms or methods used to extract and use such information from the design matrix may be provided. More particularly, algorithms that interpret or

manipulate information in the design matrix. The following algorithms, among others, may be provided to interpret and/or manipulate design matrix data:

- Algorithm to check the design status of entities of the design matrix
- Algorithm to generate rearrangement sequences for the system design
- 5 • Algorithm for ranking a design having a strong FR-DP association
- Algorithm for ranking a design having a free association of DPs
- Algorithm for generating a flowchart describing the system design
- Algorithm for generating an impact list related to the system design
- Algorithm for generating a Gantt chart related to the system design
- 10 • Algorithm for computing a full design matrix from inconsistency data
- Algorithm for displaying a full design matrix

The design matrix in the Axiomatic Design framework includes a great deal of information. It includes the design status, sequences for flowchart (or system architecture) schedule information and other information. As discussed above, the design matrix expresses the relationship between different domains (i.e., functional domain described by FR and physical domain described by DP). To interpret and manipulate this matrix, algorithms are provided that manipulate elements of the matrix. In the case of a design matrix having non-numeric information, algorithms are provided that manipulate elements having non-numerical characteristics. The basic algorithm to handle elements of the matrix is illustrated in a book entitled “The Principle of Design,” by Nam P. Suh, Oxford University Press, 1990, pp. 383-385. This algorithm modifies the matrix format by changing the order of FRs and DPs to determine if the design matrix can be manipulated into triangular form to create a decoupled design. The algorithm as shown in Figure 81 shows one algorithm according to one embodiment of the invention used to manipulate a design matrix.

According to one embodiment of the invention, a method is provided for changing the order of FRs and DPs. According to this embodiment, the following are performed:

- i) Find the row which contains one non-zero element. Rearrange the order of {FRs} and {DPs} by putting the row and the column which contain the non-zero element first (i.e. if i^{th} row contains one non-zero element at j^{th} column, then put i^{th} component of {FR} first and put j^{th} component of {DP} first.

ii) Excluding the first row and column, find the row which contain one one-zero element. Rearrange the components of {FRs} and {DPs} by putting the row and the column which contains the non-zero element at the row and column second.

5 iii) Repeat the procedure until there are no more sub-matrices to analyze.

Further, a method may be provided to check the status of the design as shown in Figure 82. More particularly, a determination and indication of the state of the design (such as not defined, uncoupled, coupled, or other state) may be performed. The result of this determination may be indicated to a user of the design system. To determine
10 whether various elements of the design are defined, a process may be performed wherein the elements are independently evaluated to determine whether they are defined. According to one aspect of the invention, an element is not defined when its element value is zero or is empty. It should be appreciated that other values may be used to indicate the element is not defined. One exemplary method for determining whether
15 elements are defined is shown in Figure 83 wherein each of the elements of the design matrix is evaluated using nested loops.

To determine whether the design is uncoupled, the value of each element of the design matrix may be evaluated. According to one embodiment of the invention as shown in Figure 84, if the value of any element is "X," then the design is not coupled.

20 Otherwise, the design is uncoupled.

Figure 85 shows a method for determining whether a design is coupled. Coupling, as discussed above, can occur when the number of DPs is less than the number of FRs, or the FRs cannot be satisfied. The method may, for example, identify the coupled rows of the design matrix and assign those rows to a coupled set. If, after the
25 design matrix is evaluated, the coupled set is empty, the design matrix represents a decoupled design. Otherwise, the design is coupled.

Figure 86 shows a method for generating rearranged sequences of the design matrix according to one embodiment of the invention. In particular, the elements of the design matrix may be rearranged to modify the design matrix in triangular form which
30 may be useful in evaluating or using the design.

Figure 87 shows a method for ranking alternative or redundant DPs.

For instance, a designer may have alternative DPs or redundant DPs in which the system may be implemented. The algorithm shown in Figure 87 describes how to rank the best combinations among these alternative or redundant DPs.

More particularly, the method shown in Figure 87 ranks designs having a strong
5 FR-DP association. This method collects the combinations among the alternatives and redundant DPs having a non-zero element in the diagonal element at the beginning of a row. Figure 88 shows a method of ranking designs having free association of DPs. More particularly, this method shown in Figure 88 finds all possible combinations of DPs that could form a basis of a design using permutation. It should be appreciated that
10 any method for ranking alternative or redundant designs may be used.

As discussed above, flowcharts may be generated that graphically describe the system design represented by the design matrix. Figure 89 shows one method for
generating flowchart sequences based on design matrix information. The method uses design matrix information to generate an edge list that determines a flowchart matrix.
15 The flowchart matrix can then be used to generate a flowchart. This flowchart graphically represents the architecture of the design. Because the method shown in Figure 89 can be used for the entire design hierarchy at each level, the algorithm shown in Figure 89 may be used to generate flowchart sequences for one level.

Figure 90 shows one exemplary format of a flowchart matrix according to one
20 embodiment of the invention. In particular, the size of the flowchart matrix is the square of the number of FRs in the system: |FR number| X |FR number|. Each cell of the matrix may relate the following information: FR number (identification) + status of FR, wherein the type of status for an FR may be, for example, one of the following status types: F = coupled (feedback junction), C = decoupled (control junction), or S = uncoupled
25 (summation junction). The information in the flowchart matrix is then used to generate a flowchart which can be used to generate other information, or the flowchart may be displayed to a user.

Figure 91 shows a method for generating an impact list. An impact list is a set of information that is affected by a change in the design hierarchy. Because the flow chart
30 shows the whole design sequence based on the design matrix, the result of flowchart matrix described above with respect to Figures 89 and 90 may be used as input data for generating the impact list. The algorithm shown in Figure 91 describes how to create the impact list based upon flowchart information.

A Gantt chart is a flow chart showing duration information for each node of the flowchart. In particular, the well-known Gantt chart displays dependencies for one or more tasks for use in project planning. A Gantt chart, according to one embodiment of the invention, may also be used to indicate dependencies in creating DPs of a system
5 design to more adequately plan a creation of the software system. The duration information should be provided in all the leaf level at least to enable a user to estimate how long it should take to create the software system. The algorithm shown in Figure 92 describes how to create the Gantt chart using information from the flowchart matrix.

Having now described a few embodiments, it should be apparent to those skilled
10 in the art that the foregoing is merely illustrative and not limiting, having been presented by way of example only. Numerous modifications and other embodiments are within the scope of one of ordinary skill in the art and are contemplated as falling within the scope of the invention.

CLAIMS

1. A digital information product comprising:
a computer-readable medium; and
stored on the computer-readable medium, computer program instructions
5 defining a software system that produces software code based on a set of functional
requirements and design parameters provided by a programmer.

2. The digital information product according to claim 1, wherein the computer
program instructions, when executed, allow the programmer to define a design matrix
10 describing a relation between the set of functional requirements and the design
parameters.

3. The digital information product according to claim 2, wherein the computer
program instructions, when executed, allow a programmer to manipulate the design
15 matrix into lower triangular form.

4. The digital information product according to claim 2, wherein the computer
program instructions, when executed, allow a programmer to determine a decoupled
design matrix.
20

5. The digital information product according to claim 2, wherein the computer
program instructions, when executed, allow a programmer to determine an uncoupled
design matrix.

- 25 6. A method for producing a software system, the method comprising:
defining a design matrix describing a relation between functional requirements of
the software system and design parameters; and
generating software code based on the design matrix.

- 30 7. The method according to claim 6, further comprising a step of constructing
functions using diagonal elements of the design matrix.

- 80 -

8. The method according to claim 6, further comprising a step of defining a flow description that describes a flow of the software system.
9. The method according to claim 6, further comprising a step of defining a software module corresponding to at least one functional requirement.
10. The method according to claim 9, wherein the software module is defined based upon the flow description.
11. The method according to claim 6, further comprising a step of defining a plurality of software modules, each of which corresponds to a respective functional requirement.
12. The method according to claim 11, further comprising relating the plurality of software modules by junctions.
13. The method according to claim 12, further comprising a step of combining the plurality of software modules according to their junctions.
14. The method according to claim 13, wherein at least one of the junctions is selected from a group including:
15. A method for producing software comprising:
defining a design matrix describing a relation between functional requirements of the software system and design parameters; and
generating software code based on the design matrix.
16. The method according to claim 15, wherein the step of defining includes determining a design matrix having a lower triangular form.
17. The method according to claim 15, wherein the step of defining includes determining an uncoupled design matrix.

18. The method according to claim 15, wherein the step of defining includes determining a design matrix having a diagonal form.
19. The method according to claim 15, wherein the step of defining includes
5 determining a decoupled design matrix.
20. The method according to claim 15, wherein the step of generating comprises:
generating a plurality of models; and
outputting the models to a code generator.
10
21. The method according to claim 15, wherein the step of generating comprises
generating at least one diagram describing an object-oriented object structure.
22. The method according to claim 21, wherein the at least one diagram is in a
15 Unified Modeling Language format.
23. The method according to claim 21, wherein the at least one diagram includes at
least one of a group of diagrams comprising:
a use-case diagram; and
20 an entity-relation diagram.
24. The method according to claim 15, wherein the code generated includes object-
oriented entities.
25. The method according to claim 15, further comprising a step of defining an
25 object-oriented class using at least one functional requirement.
26. The method according to claim 24, further comprising a step of defining a child
of the object-oriented class using at least one functional requirement.
30
27. The method according to claim 25, further comprising a step of defining a
grandchild of the object-oriented class using at least one functional requirement.

- 82 -

28. The method according to claim 27, wherein the grandchild of the object-oriented class defines behavior of the class.
29. The method according to claim 24, wherein at least one functional requirement
5 represents at least one object-oriented software entity.
30. The method according to claim 15, wherein the generated software code is Source Code.
- 10 31. A method for designing software involving object-oriented software objects, the method comprising:
defining a design matrix describing a relation between a plurality of functional requirements of the software system and design parameters;
representing at least one object-oriented object by at least one of the functional
15 requirements;
representing data used by the at least one object-oriented software object by at least one of the design parameters; and
representing a method of the at least one object-oriented software object by a product of a portion of the design matrix and the at least one design parameter.
- 20 32. The method according to 31, further comprising defining a plurality of functional requirements and constraints of the software system.
33. The method according to 31, comprising a step of decomposing at least one
25 functional requirement into leaf elements.
34. The method according to 31, comprising a step of decomposing at least one design parameter into leaf elements.
- 30 35. The method according to 31, comprising a step of decomposing at least one process variable into leaf elements.

36. A method for designing software comprising:
defining a software system by defining a design matrix describing a relation
between functional requirements of the software system and design parameters
implementing the software system;
- 5 defining at least one object-oriented object; and
defining at least one method that may be defined on the at least one object,
wherein the at least one object-oriented object and the at least one method are related to
the design matrix.
- 10 37. The method according to claim 36, further comprising defining an object class of
the at least one object-oriented object that represents a first level of functional
requirements of the design matrix.
38. The method according to claim 37, further comprising defining an instance of the
15 object class represented by a second level of functional requirements of the design
matrix.
39. The method according to claim 38, further comprising defining behavior of the
object class as a third level of functional requirements of the design matrix.
- 20 40. The method according to claim 39, wherein the first, second, and third levels are
successive levels of a functional requirement hierarchy.
41. The method according to claim 36, further comprising mapping the functional
25 requirements into a physical implementation domain by defining design parameters.
42. The method according to claim 36, further comprising a step of construction
functions using diagonal elements of the design matrix.
- 30 43. The method according to claim 36, wherein the step of defining a software
system includes determining whether the design matrix is uncoupled.

44. The method according to claim 36, further comprising generating a plurality of models and outputting the models to a code generator.
45. The method according to claim 44, wherein the step of generating comprises
5 generating at least one diagram describing an object-oriented system structure.
46. The method according to claim 45, wherein the at least one diagram includes at least one of a group of diagrams including:
a use-case diagram; and
10 an entity-relation diagram.
47. The method according to claim 45, wherein the at least one diagram is in a Unified Modeling Language format.
- 15 48. A database format for designing a software system comprising:
a software design specification, wherein the design specification defines a design matrix describing a relation between a plurality of functional requirements of the software system and design parameters, wherein the design specification represents at least one software object by at least one of the functional requirements, and wherein the
20 design specification represents data used by the at least one software object by at least one of the design parameters; and
software code produced by the design specifications.
49. The database format according to claim 48, wherein the software design
25 specification further comprises a design identification identifying the software code.
50. The database format according to claim 48, wherein the software design specification further comprises a detailed design description including the design matrix, functional requirements and design parameters.
30
51. The database format according to claim 49, wherein the software design specification further comprises a detailed design description including the design matrix, functional requirements and design parameters.

52. The database format according to claim 49, wherein the software design specification further comprises a design identification identifying the software code.

5 53. The database format according to claim 48, wherein the design parameters are arranged in a plurality of levels, and wherein each of the plurality of levels can be referenced by another software system.

54. The database format according to claim 48, wherein the database format for
10 designing a software system is used in a software production system, and a user operating the software production system is capable of creating software comprising one or more elements of the software system.

55. The database format according to claim 54, wherein the software production
15 system further comprises a user interface and a database implementing the database format, and the software production system is capable of searching through the database to obtain one or more elements of the software system to create a new software system.

56. The database format according to claim 55, wherein a new element of the new
20 software system interfaces with one or more elements of the software system, and the software production system is operable to verify that the interface is operable.

57. The database format according to claim 55, wherein the software production
25 system is configured to verify a consistency of design of the new software system.

58. The database format according to claim 55, wherein the software production
system is configured to search design parameter information, including at least one of
description information, keywords associated with the software system, categories in
which the software system is assigned, and comments.

30

59. The database format according to claim 48, wherein the software code is in executable form.

60. The database format according to claim 48, wherein the software code is source code.
61. The database format according to claim 57, wherein the software production
5 system is configured to verify a consistency of design of the new software system by checking a consistency between a first level of design implementing a design parameter from the database and a second level of design of the new software system.
62. The database format according to claim 61, wherein the second level of design is
10 a child of the first level of design.
63. The database format according to claim 55, wherein a new element of the new software system interfaces with one or more elements of the software system, and the software production system is operable to verify that the interface is operable.
15
64. A database format for designing a software system comprising:
design identification information identifying information describing the software system;
detailed design description information describing the structure and operating
20 qualities of the software system; and
software code information associated with the software system.
65. The database format according to claim 64, wherein the detailed design
description defines a design matrix describing a relation between a plurality of functional
25 requirements of the software system and design parameters, wherein the design specification represents at least one software object by at least one of the functional requirements, and wherein the detailed design description represents data used by the at least one software object by at least one of the design parameters.
- 30 66. The database format according to claim 64, wherein the software code information comprises source code.

67. A method for generating software code associated with a software system, the method comprising:
defining a design matrix describing a relation between functional requirements of the software system and design parameters; and
5 generating software code based on the design matrix.
68. The method according to claim 67, further comprising defining a plurality of functional requirements and constraints of the software system.
- 10 69. The method according to claim 67, further comprising a step of decomposing at least one functional requirement into leaf elements.
70. The method according to claim 67, further comprising a step of decomposing at least one design parameter into leaf elements.
- 15 71. The method according to claim 67, further comprising a step of decomposing at least one process variable into leaf elements.
72. The method according to claim 67, wherein the software code is written in a modeling code language.
- 20 73. The method according to claim 67, wherein the software code is executable by a computer system.
- 25 74. The method according to claim 72, wherein the modeling code language is the Unified Model Language (UML).
75. The method according to claim 72, wherein the software code describes at least one diagram of a group comprising:
30 a class diagram;
an interaction diagram;
a collaboration diagram;
a sequence diagram;

- 88 -

a state diagram; and
an activity diagram.

76. The method according to claim 75, further comprising a step of relating the
5 design matrix to at least one element of the at least one diagram.

77. The method according to claim 72, wherein the system creates a use-case
diagram based upon the design matrix.

10 78. The method according to claim 67, further comprising defining a plurality of
customer needs, the plurality of needs being arranged in a hierarchical tree having levels,
and wherein at least one of the levels relates to a layer of a use-case diagram.

79. The method according to claim 67, wherein the use-case diagram includes a
15 relation layer, a use case layer and an actor layer.

80. The method according to claim 79, wherein the actor layer represents one or more
actors.

20 81. The method according to claim 79, wherein the use case layer describes customer
needs that are attributed to the actor.

82. The method according to claim 79, wherein the relation layer describes a
relationship between customer needs in customer needs in the use case layer.

25

83. The method according to claim 82, wherein the relationship is a semantic
connection among model elements.

84. The method according to claim 82, wherein the software code includes a model
30 file which describes the modeling code.

85. The method according to claim 84, wherein the model file is suitable for use as
an input file for use by a software production system to create a software system.

86. A computer-readable medium encoded with a program that, when executed on a computer system, performs a method for rendering an interface through which a user may interact, the method comprising steps of:

5 displaying a software design interface, wherein the interface displays a set of functional requirements upon which a software design is based, and wherein the interface displays a design matrix describing a relation between the set of functional requirements and design parameters implementing the software design.

10 87. The computer-readable medium according to claim 86, wherein the computer system performs a step of indicating, in association with the displayed design matrix, whether the software design specified by the design matrix is at least one of a group including a decoupled, uncoupled or coupled design.

15 88. The computer-readable medium according to claim 86, wherein the design matrix represents a coupled design, and wherein the computer system performs a step of indicating, in association with the displayed design matrix, whether a design parameter associated with the design matrix is coupled.

20 89. The computer-readable medium according to claim 88, wherein the computer system performs a step of indicating, for the design parameter associated with the design matrix, an alternate rearrangement of the design parameter wherein the design parameter, if rearranged, is uncoupled or decoupled.

25 90. The computer-readable medium according to claim 88, wherein the computer system performs a step of indicating, for the design matrix, an accuracy of the software design with respect to an optimum design.

30 91. The computer-readable medium according to claim 86, wherein the computer system performs a step of indicating, for the design matrix, a range of acceptable inputs over which the design matrix operates.

- 90 -

92. The computer-readable medium according to claim 86, wherein the computer system performs a step of arranging and displaying the functional requirements and design parameters to the user in a hierarchical manner.
- 5 93. The computer-readable medium according to claim 92, wherein the computer system performs a step of displaying the functional requirements and design parameters in a hierarchical tree having a plurality of levels.
94. The computer-readable medium according to claim 90, wherein the computer
10 system performs a step of indicating a robustness of the software.
95. The computer-readable medium according to claim 92, wherein the computer system performs a further step of creating, based upon an arrangement of the design parameters, a Gantt chart describing production dependencies of the software design.

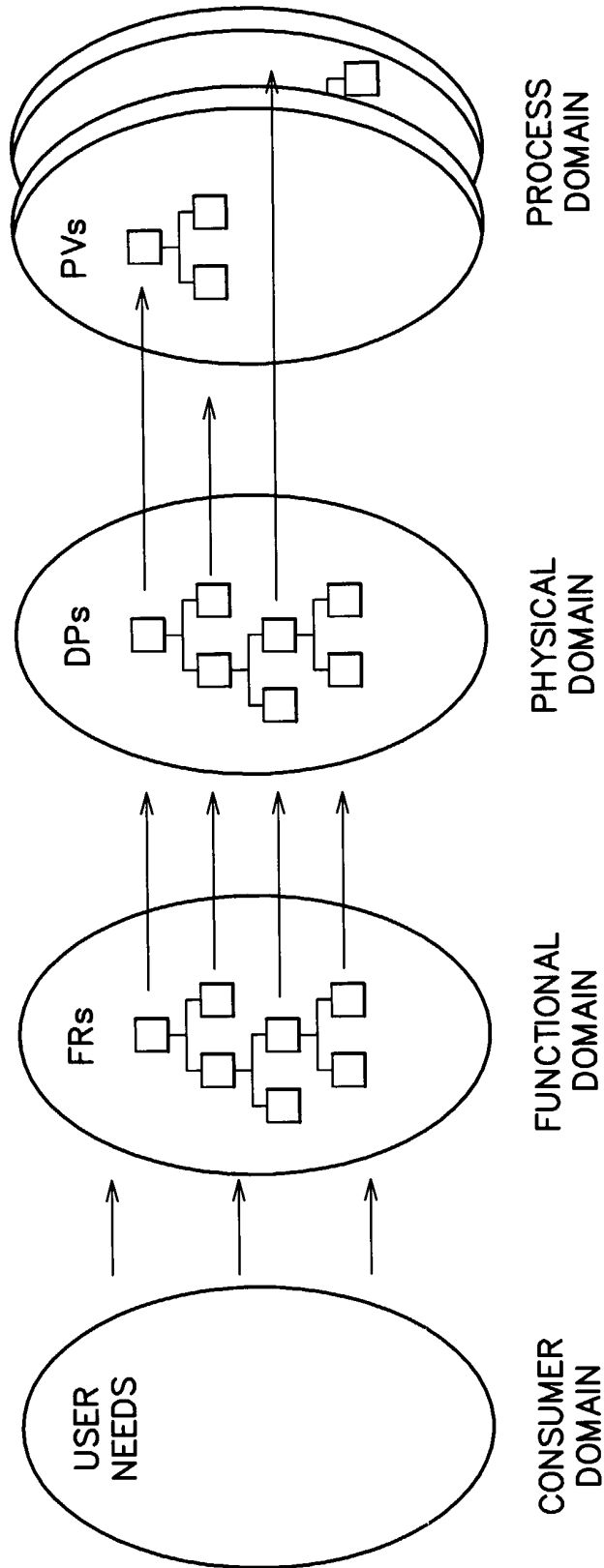

FIG. 1

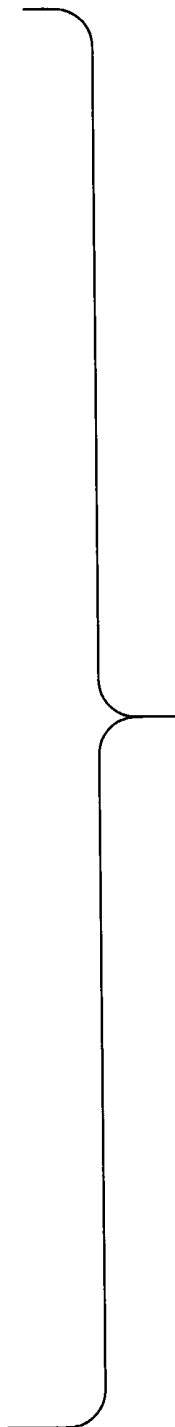
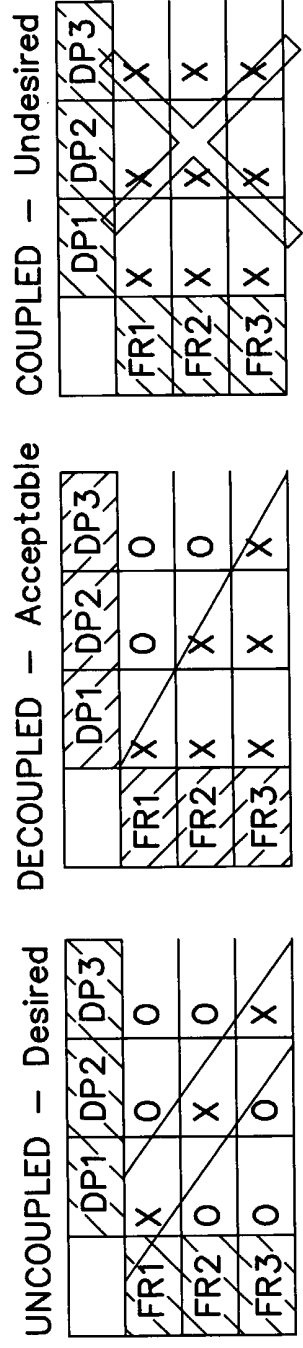

FIG. 2

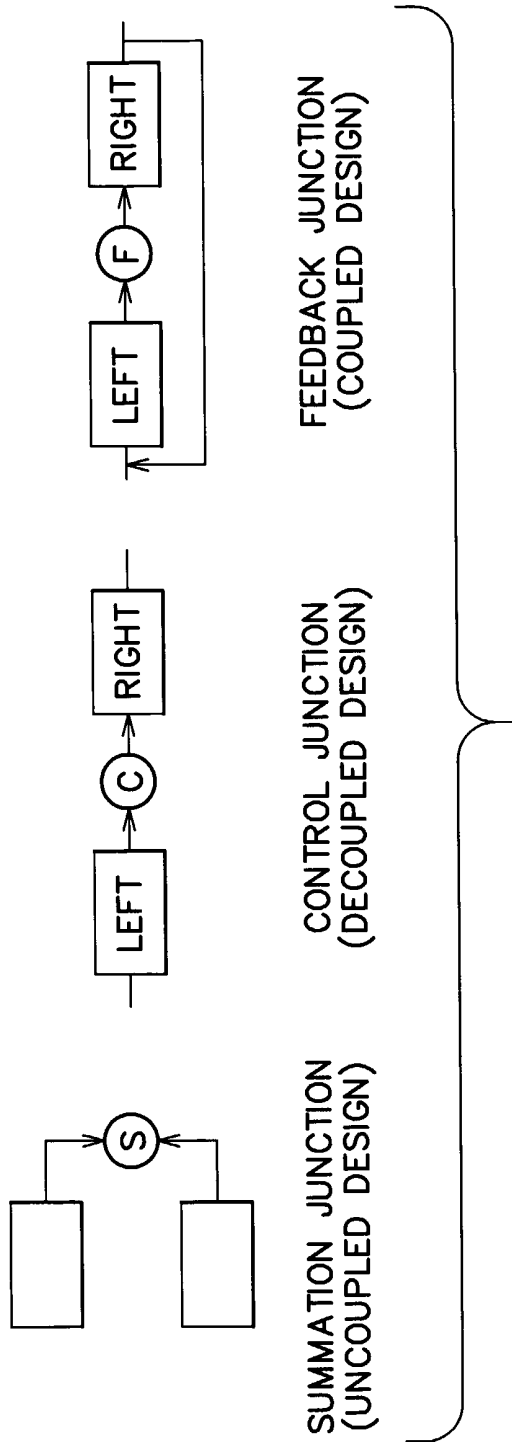

FIG. 3

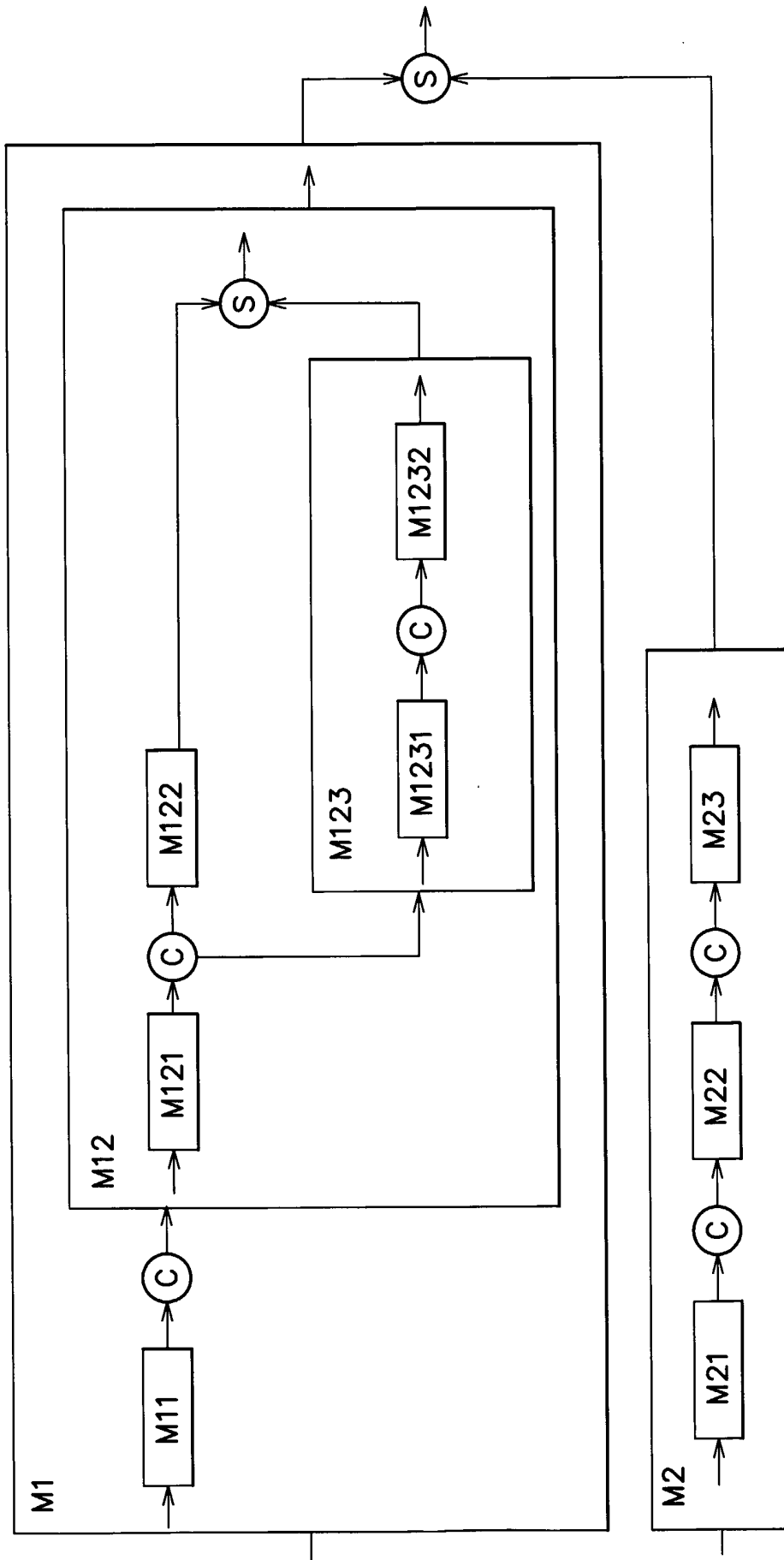

FIG. 4

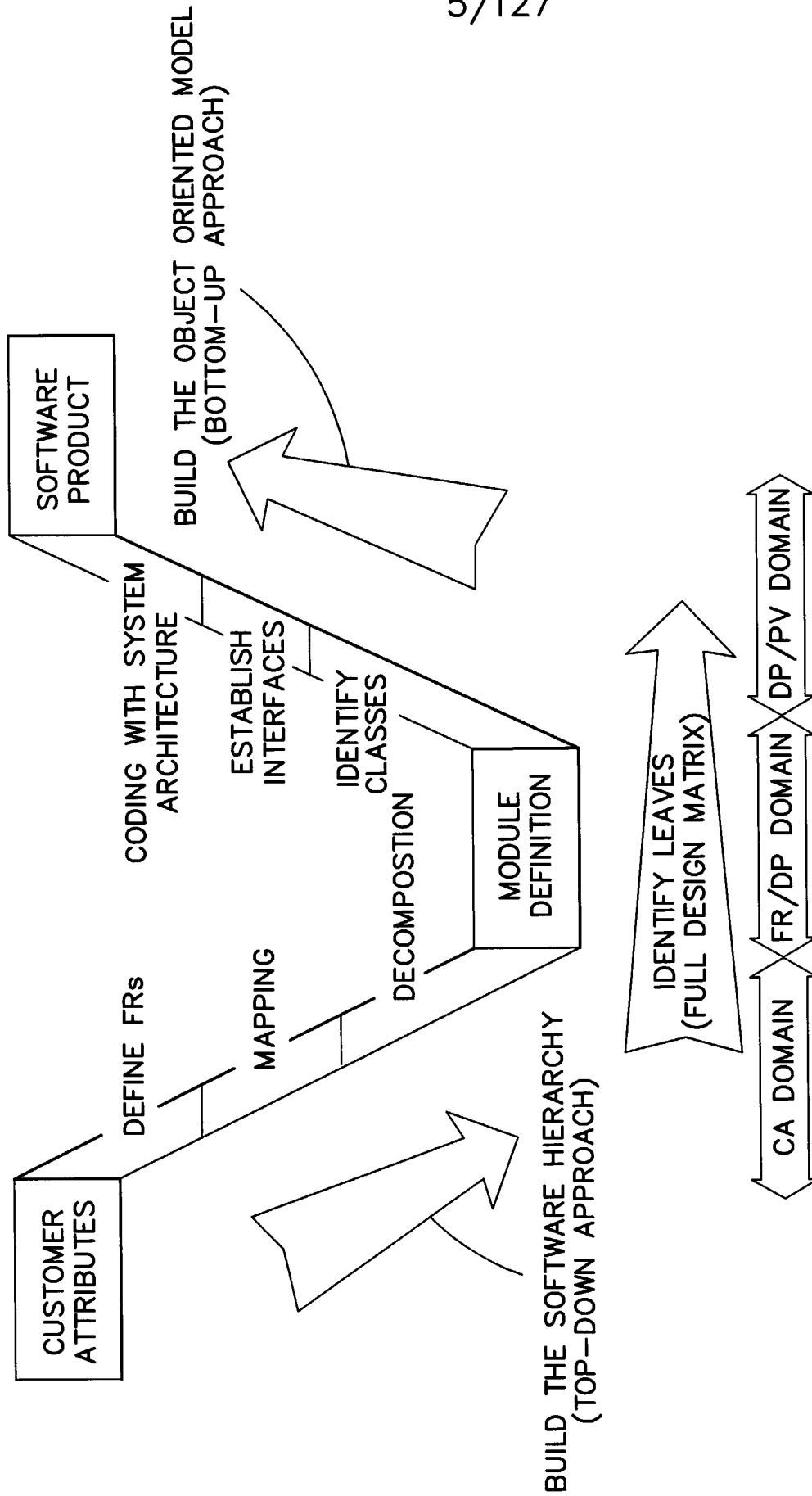

FIG. 5

6/127

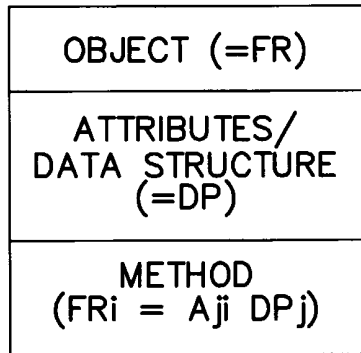
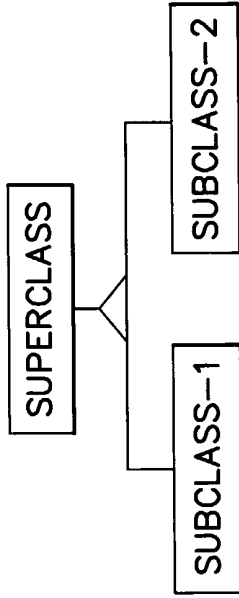
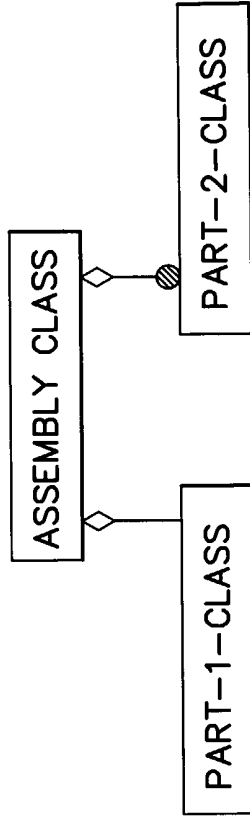

FIG. 6

GENERALIZATION (INHERITANCE):



AGGREGATION:



ASSOCIATION:



CLASS:

CLASS NAME

CLASS NAME
attribute attribute: data_type attribute: data_type=init_value ...
operation operation(arg_list): return_type ...

MULTIPLICITY OF ASSOCIATIONS:

- CLASS EXACTLY ONE
- / CLASS MANY (ZERO OR MORE)
- CLASS OPTIONAL (ZERO OR ONE)
- 1+ CLASS ONE OR MORE
- 1-2,4 CLASS NUMERICALLY SPECIFIED

FIG. 7

8/127

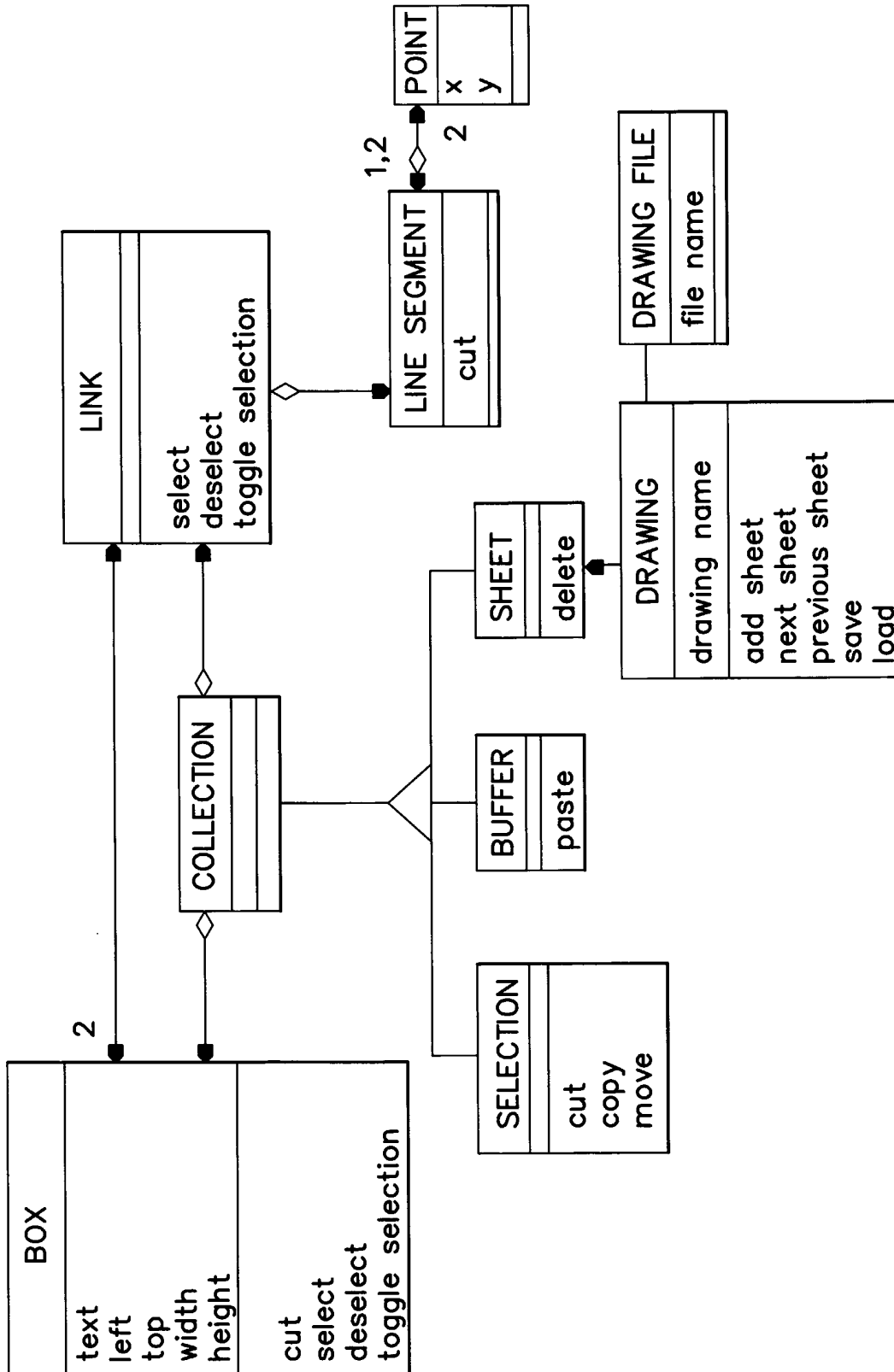

FIG. 8

9/127

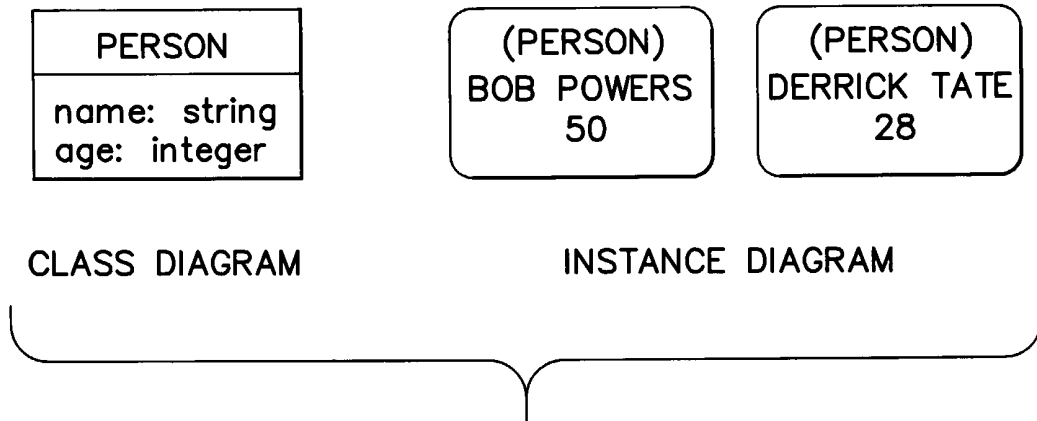

FIG. 9

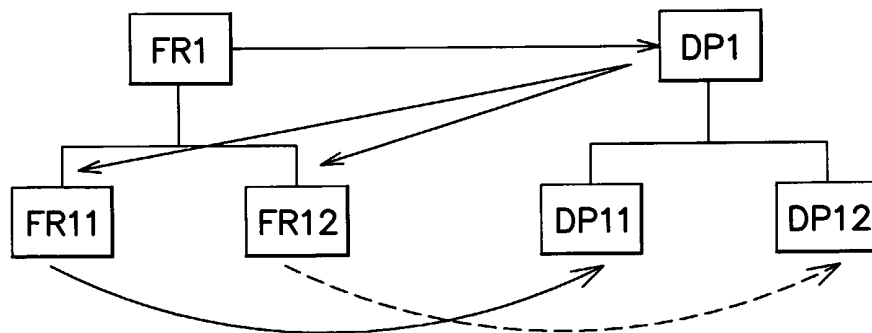

FIG. 10

10/127

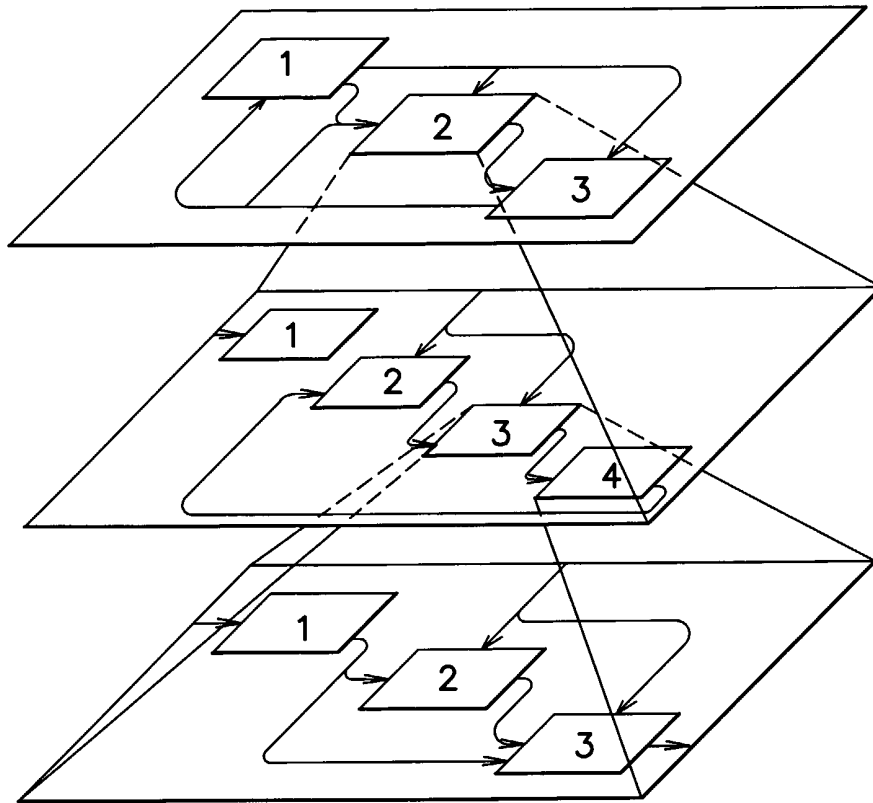

FIG. 11

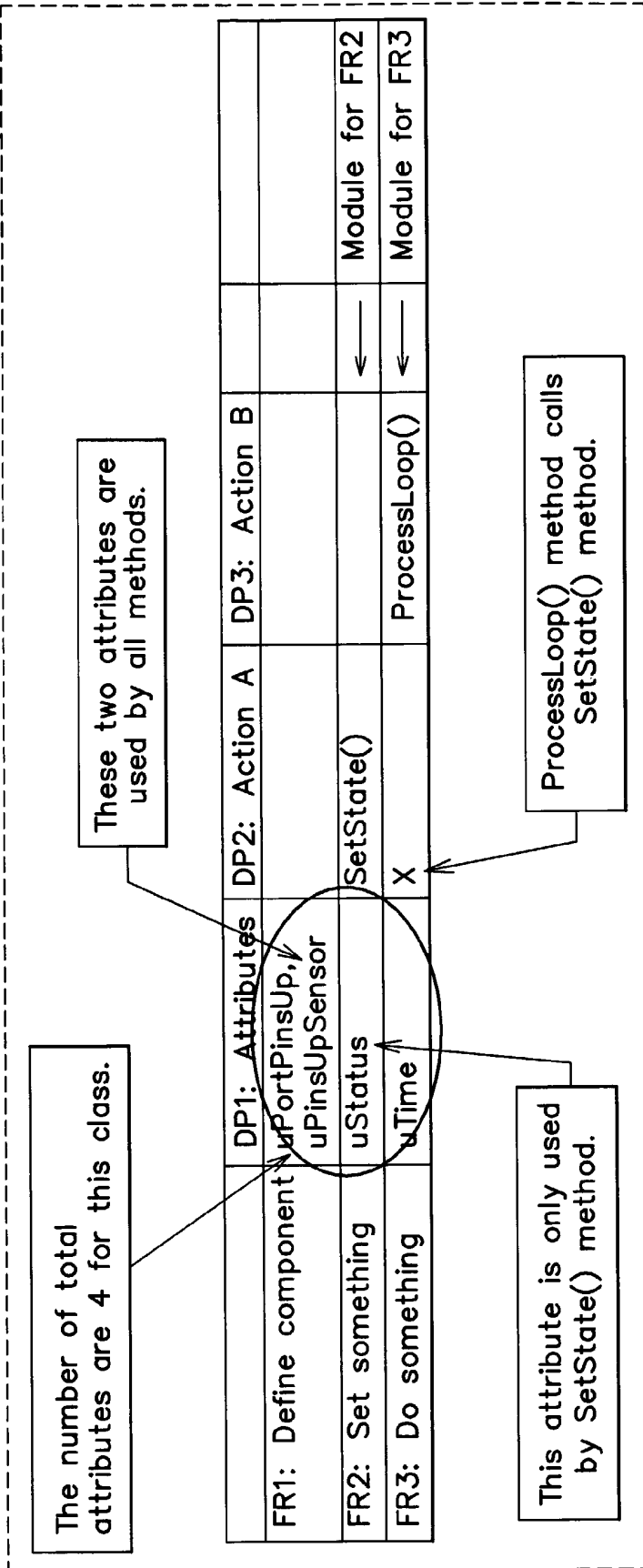
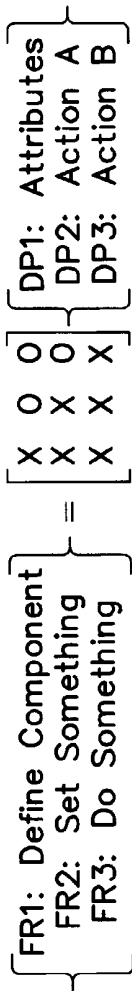

FIG. 12

12/127

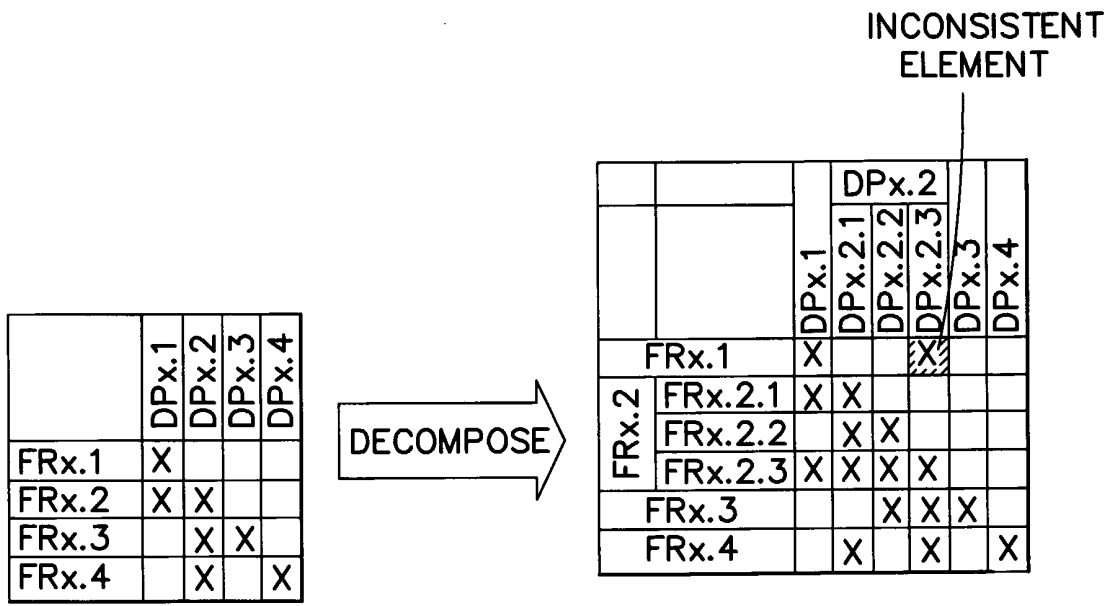

FIG. 13

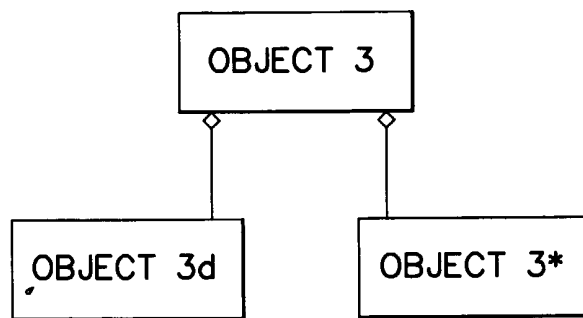

FIG. 14

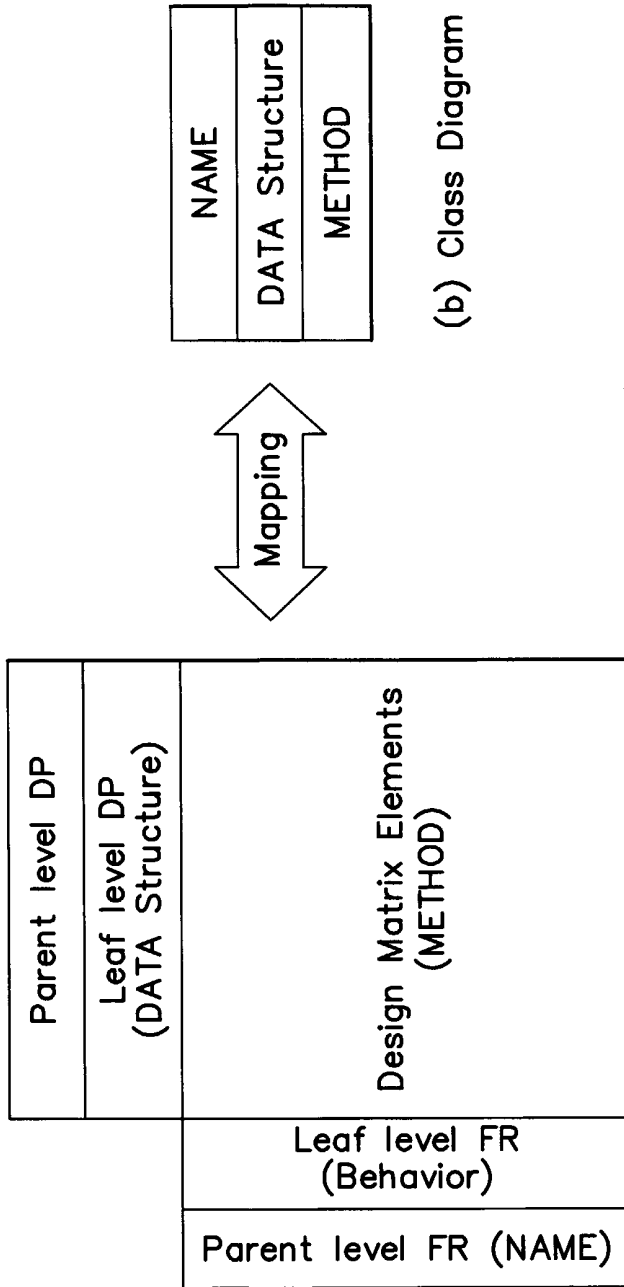

FIG. 15

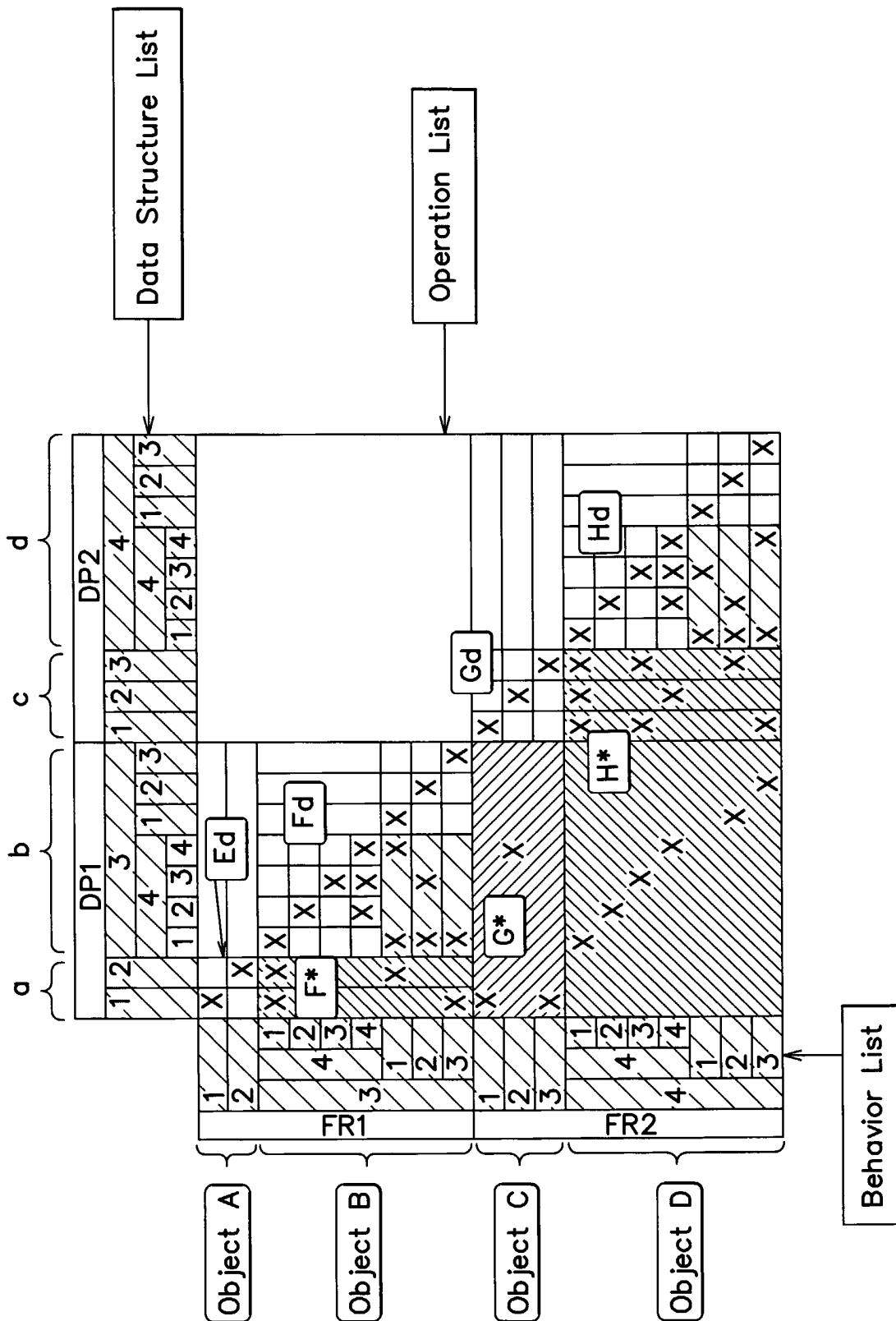

FIG. 16

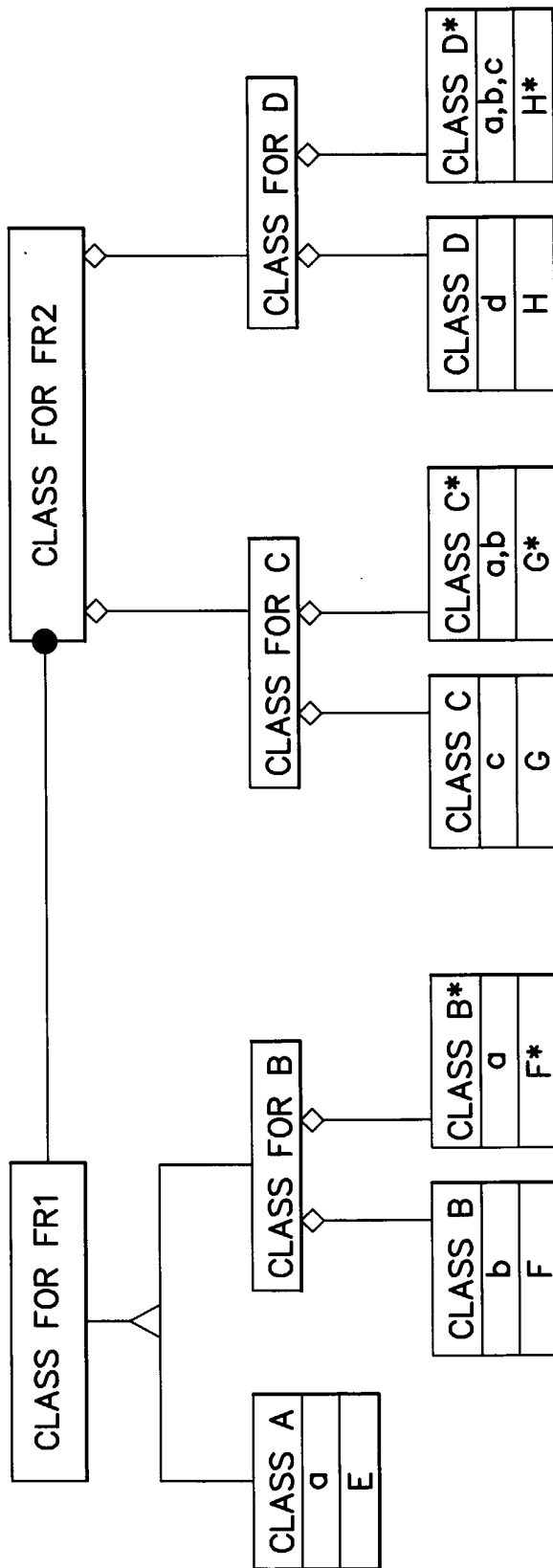

FIG. 17

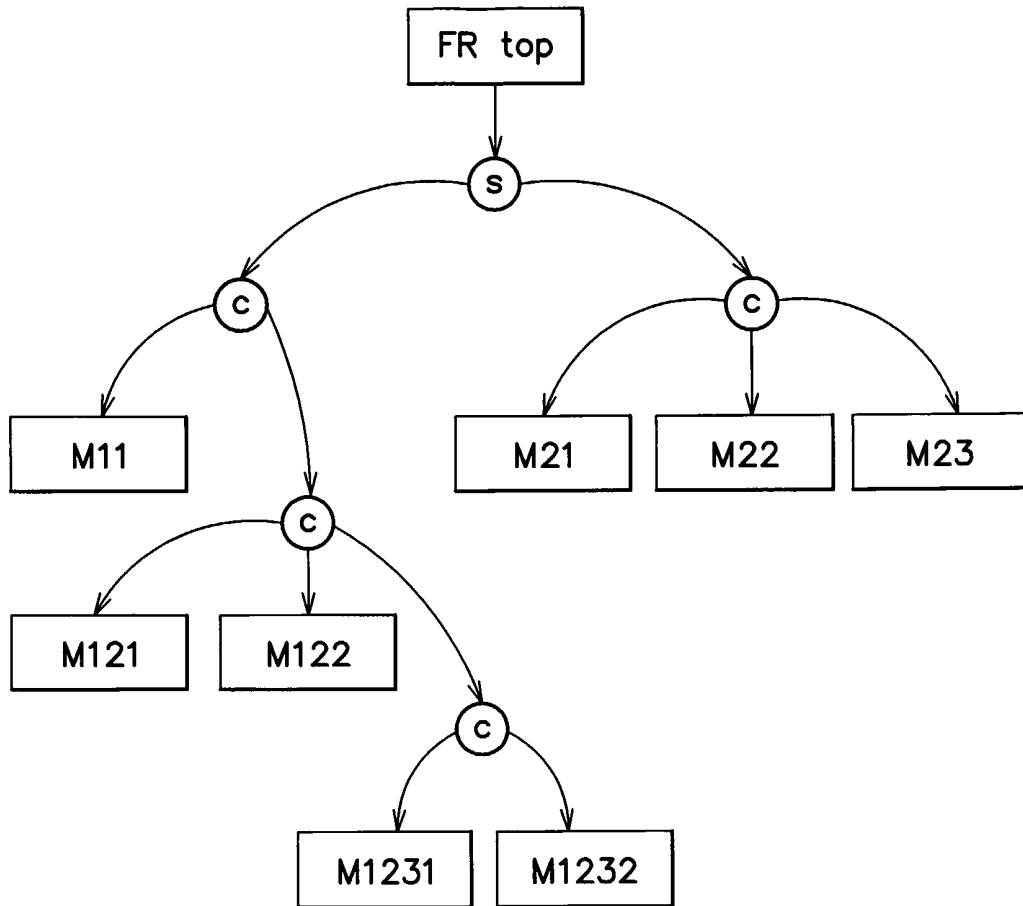

FIG. 18

17/127

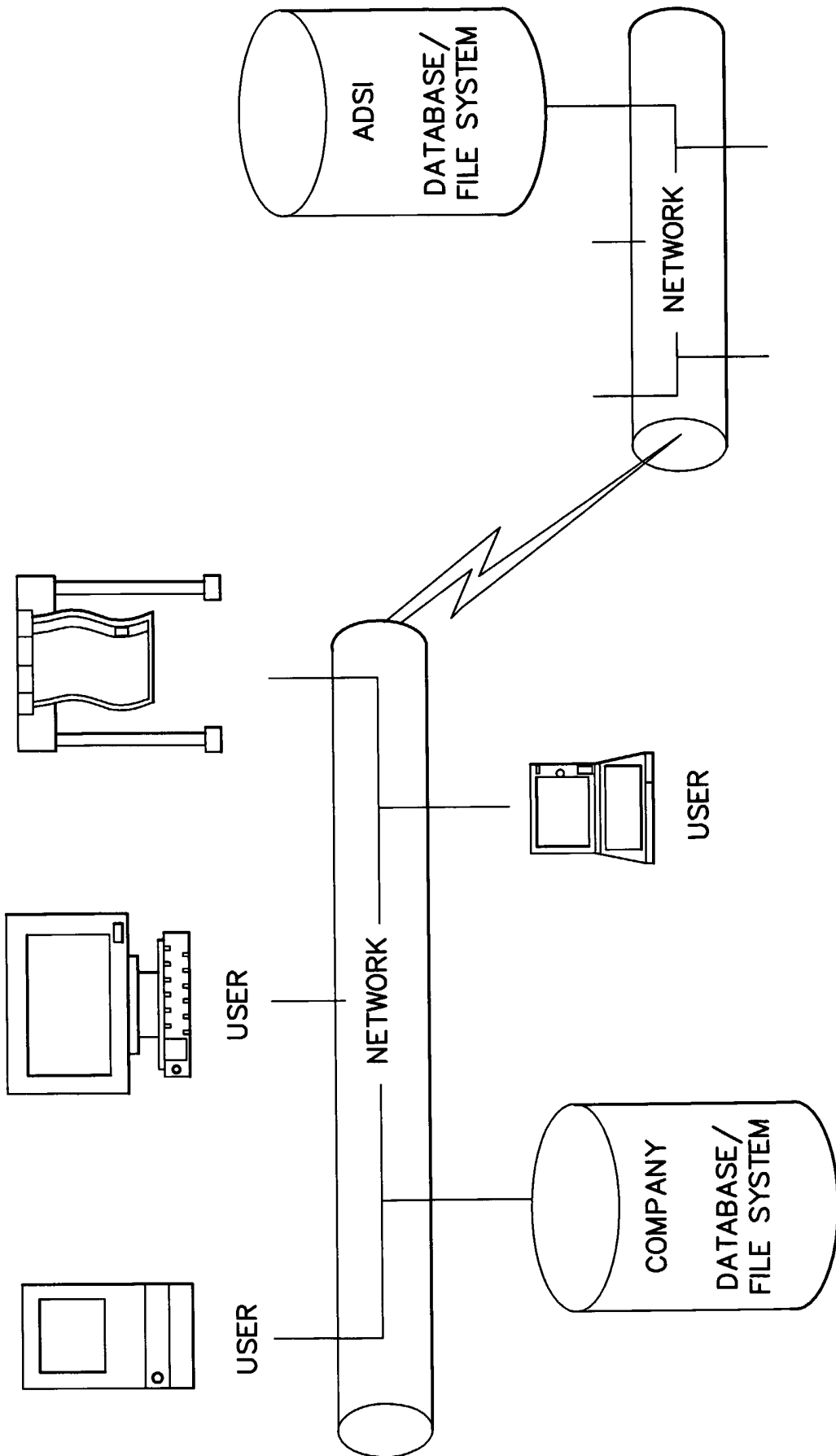

FIG. 19

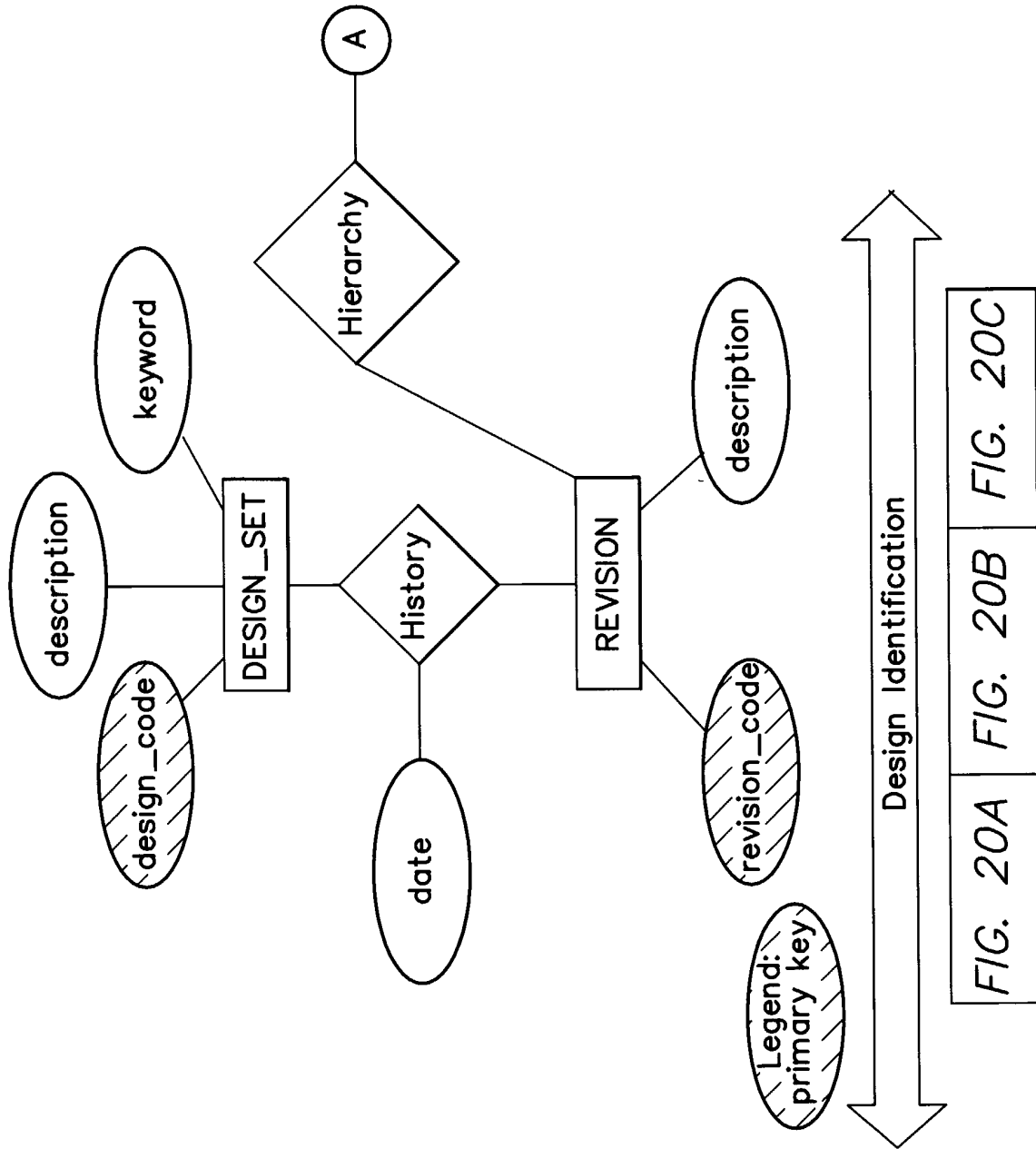

FIG. 20A

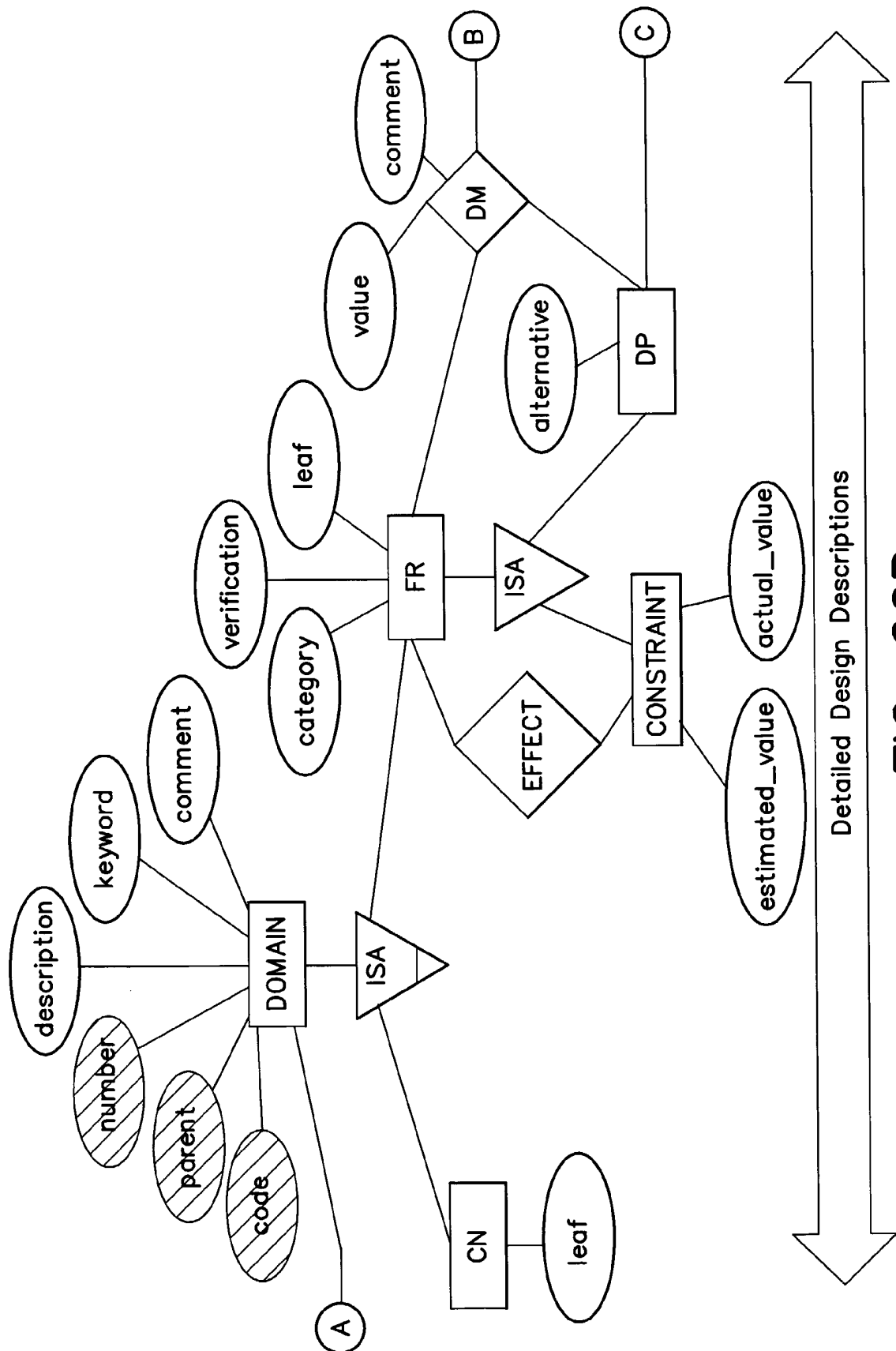

FIG. 20B

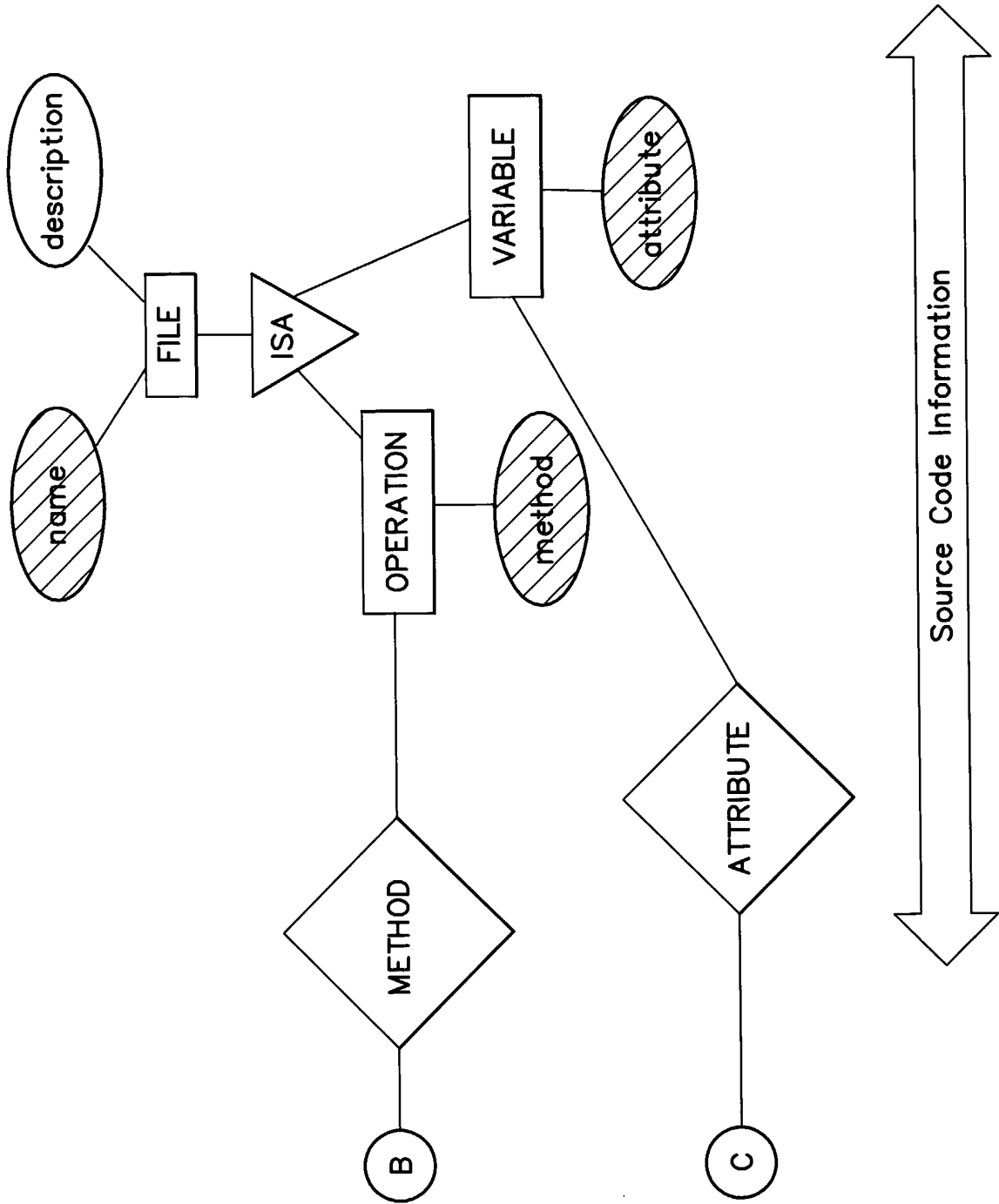

FIG. 20C

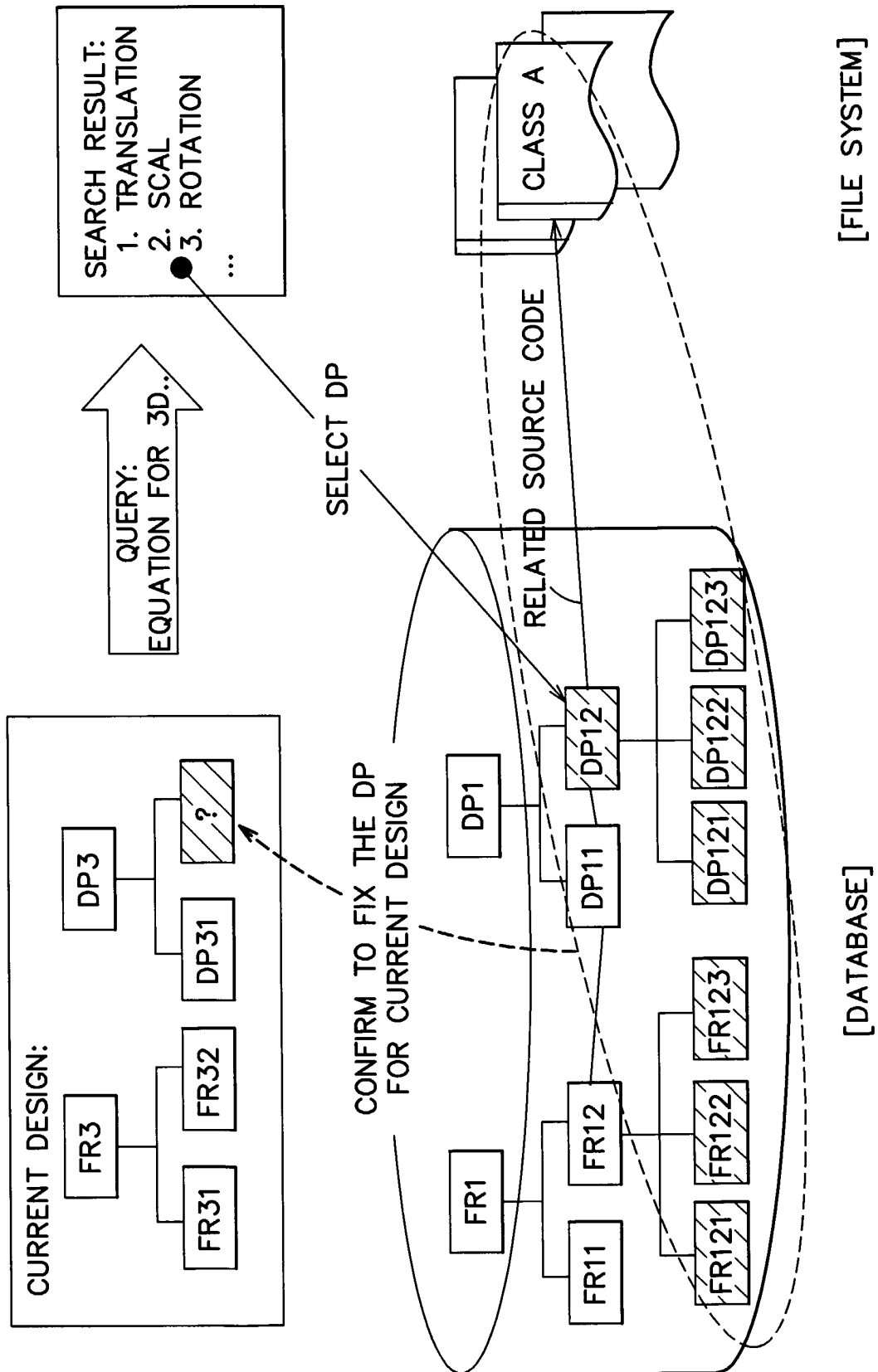

FIG. 21

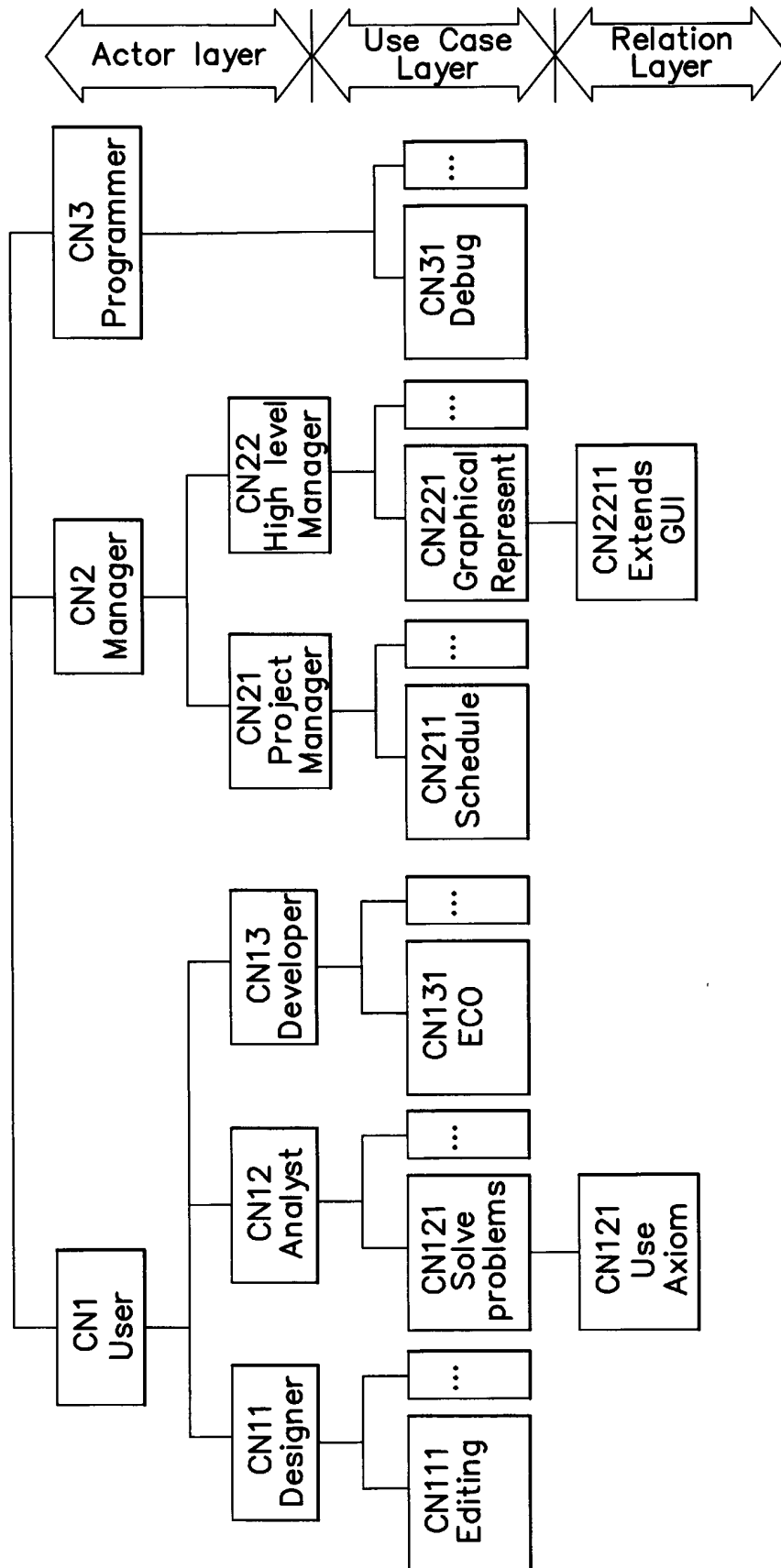

FIG. 22

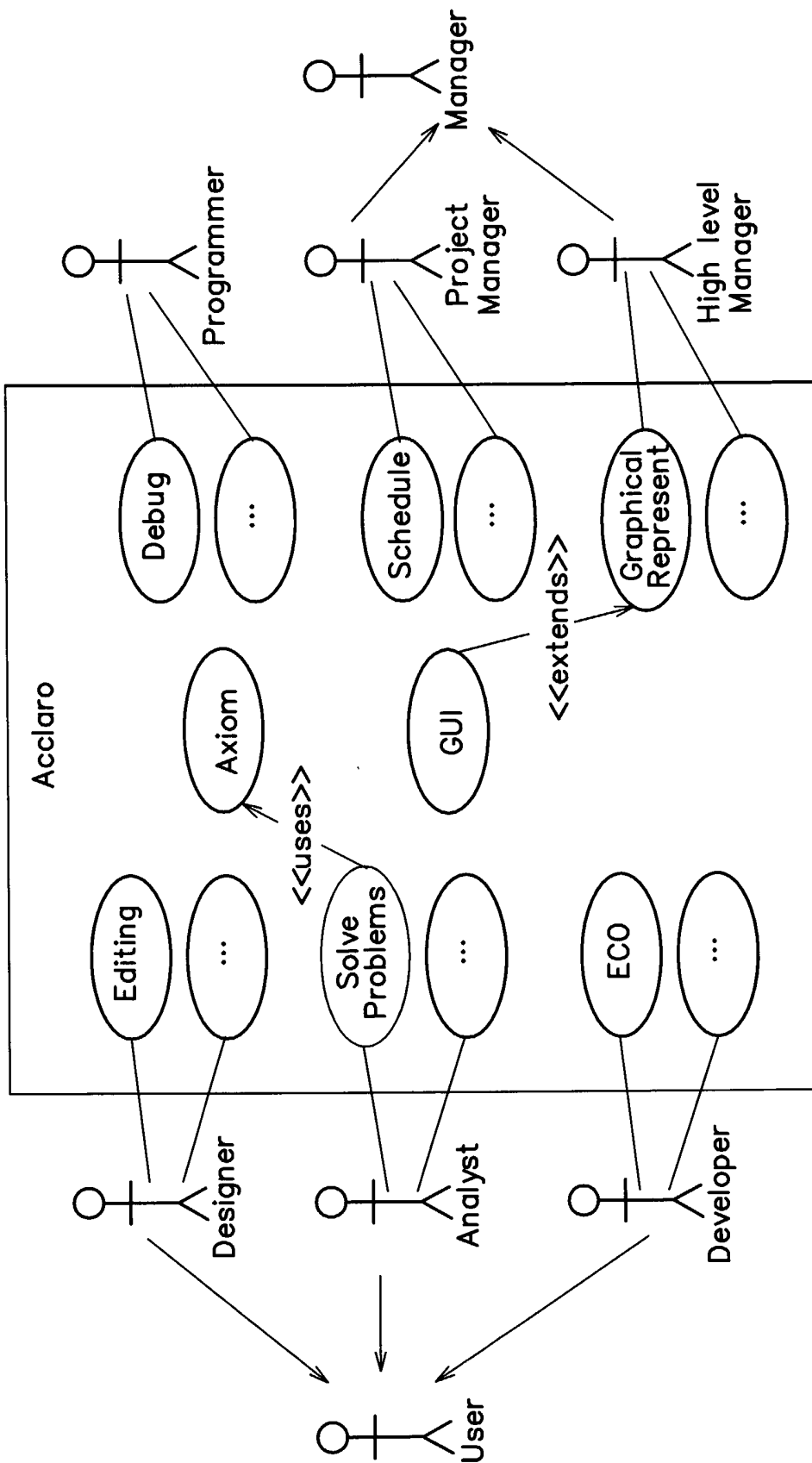

FIG. 23

24/127

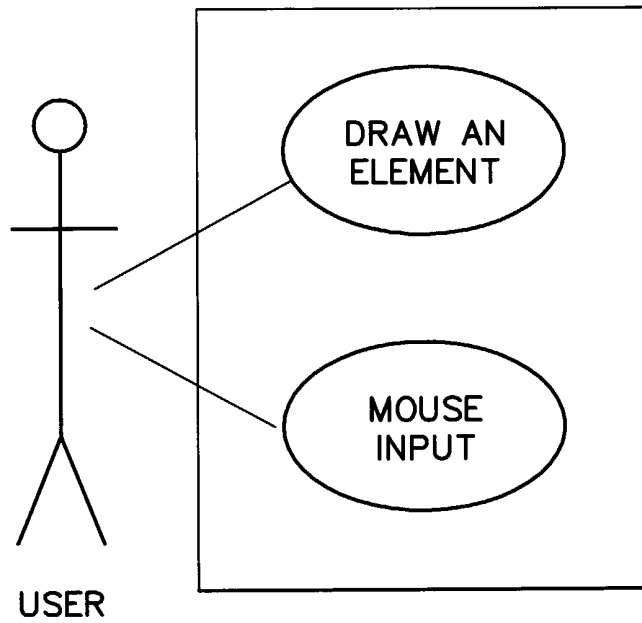

FIG. 24

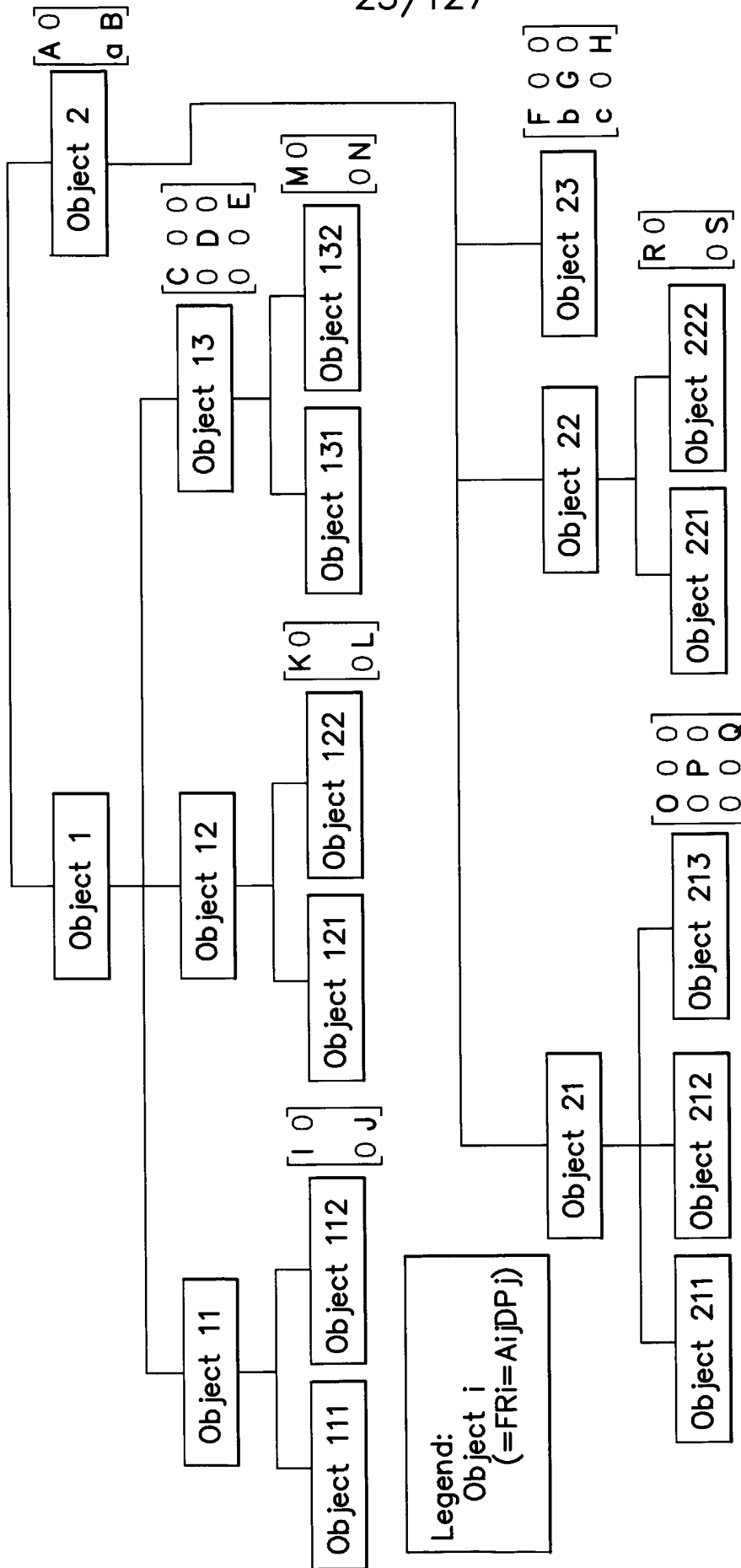

FIG. 25

		DP1: Element characteristics			DP2: GUI with window			
		DP11: Line characteristics	DP12: Rectangle characteristics	DP13: Circle characteristics	DP21: Radio buttons	DP22: Mouse click information	DP23: Drawing area	
<div style="border: 1px solid black; padding: 2px; margin-bottom: 5px;">On-diagonal element for the intermediate or higher level.</div> <div style="border: 1px solid black; padding: 2px; margin-bottom: 5px;">Off-diagonal element for the intermediate or higher level.</div> <div style="border: 1px solid black; padding: 2px;">Off-diagonal element for the leaf or lower level</div>	FR11: Define line element	DP111: Start point	DP121: Upper left point	DP131: Center point	DP211: Line button	DP221: Event for push		
	FR12: Define rectangle element	DP112: End point	DP122: Lower right point	DP132: Radius	DP212: Rectangle button	DP222: Event for release		
	FR13: Define circle element				DP213: Circle button			
	FR21: Identify the drawing type							
	FR22: Detect drawing location							
	FR23: Draw the element							
	FR1: Define element							
	FR2: Specify drawing							

FIG. 26

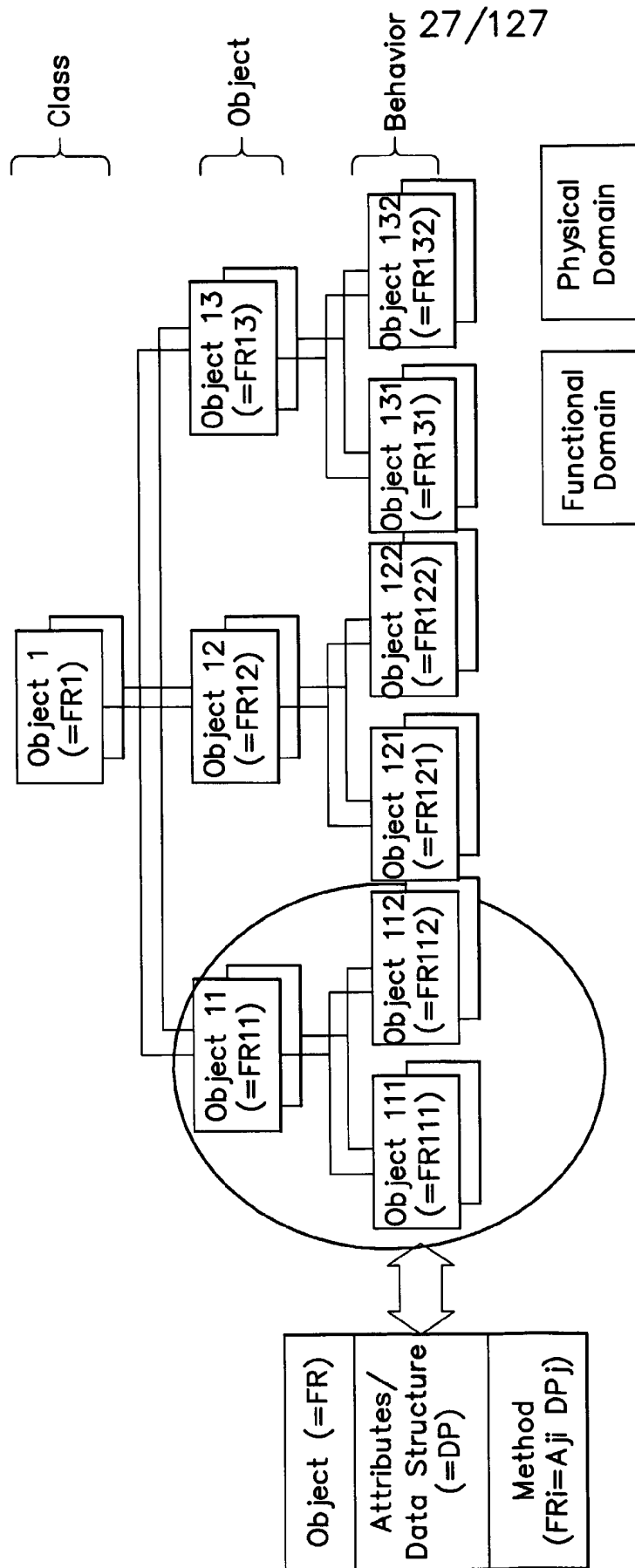
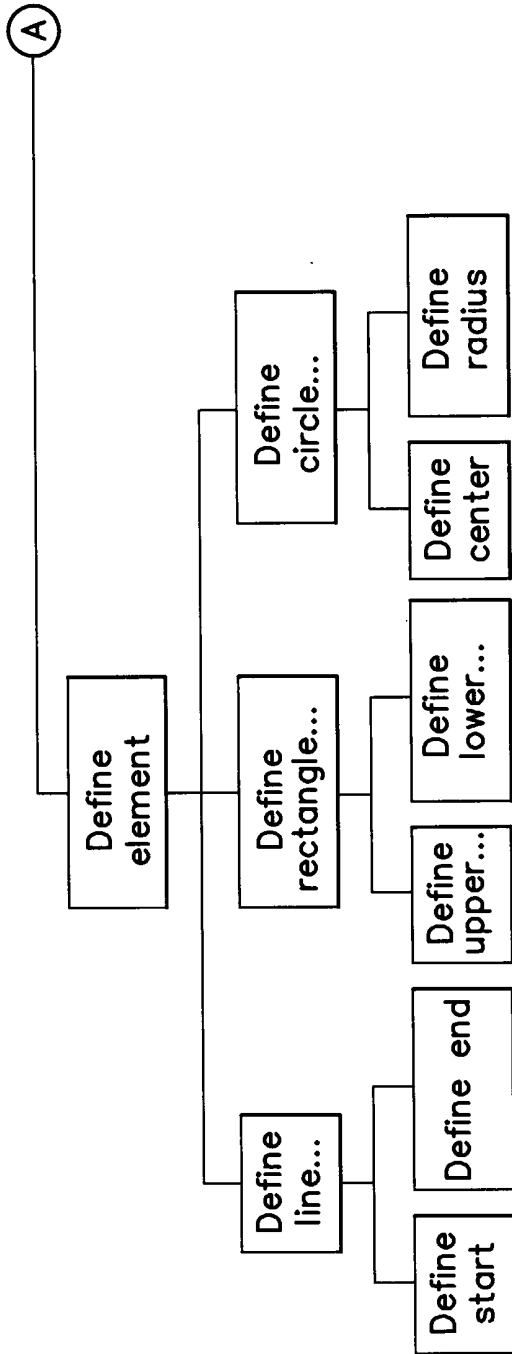

FIG. 27



(a) Functional Domain

FIG. 28A(1) | FIG. 28A(2)

FIG. 28A(1)

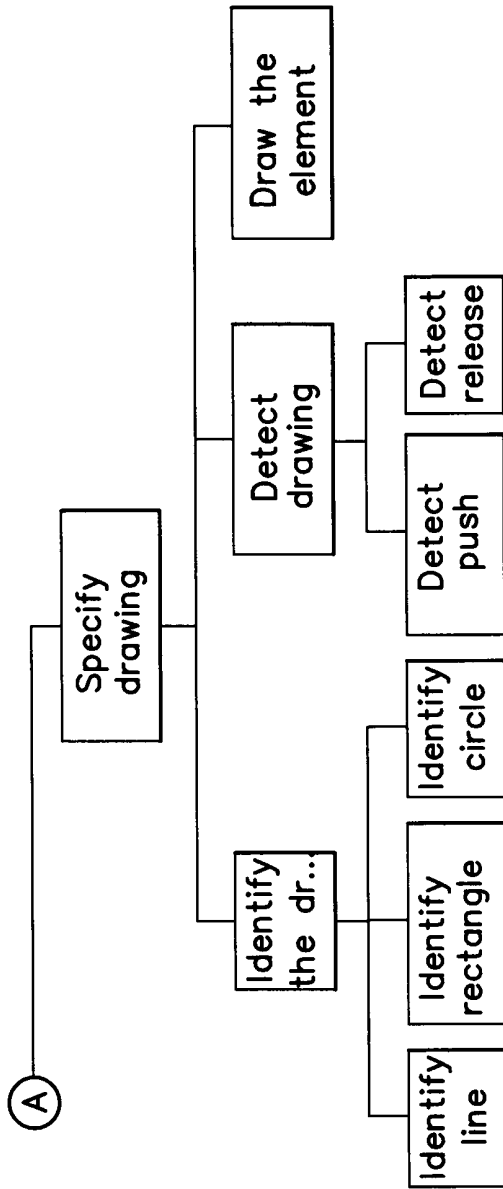

(a) Functional Domain

FIG. 28A(2)

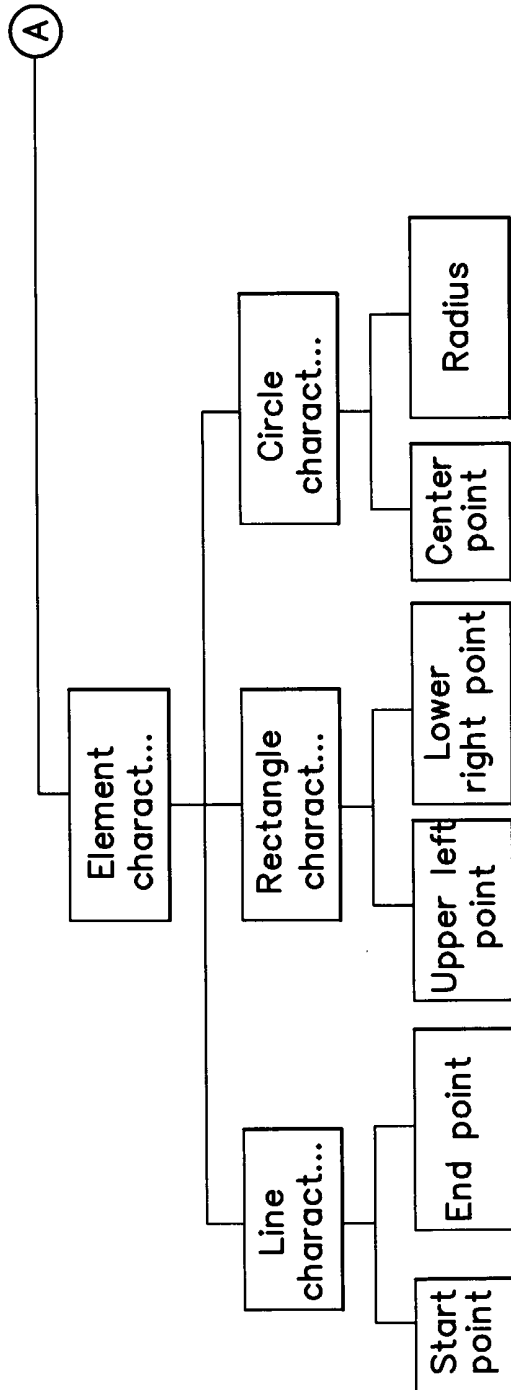

(b) Physical Domain

FIG. 28B(1) | FIG. 28B(2)

FIG. 28B(1)

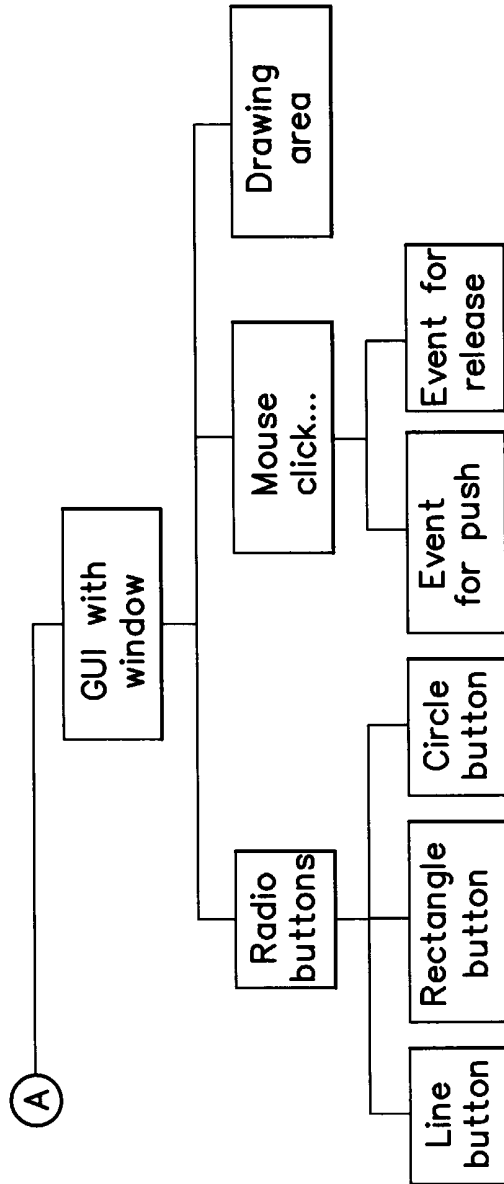

(b) Physical Domain

FIG. 28B(2)

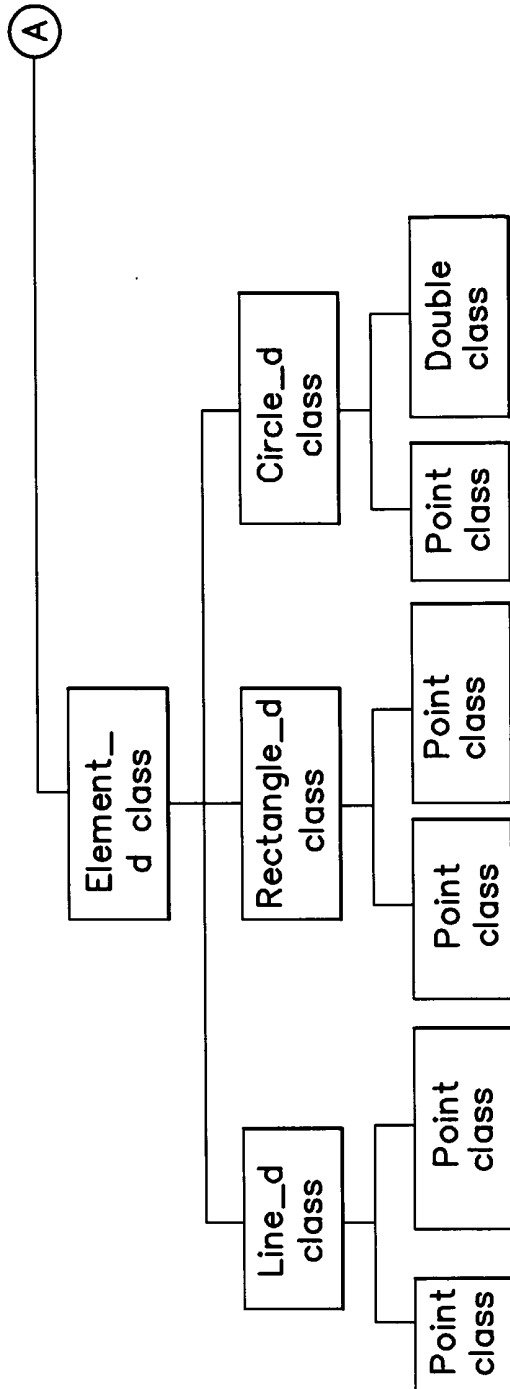

(c) Process Domain

FIG. 28C(1) FIG. 28C(2)

FIG. 28C(1)

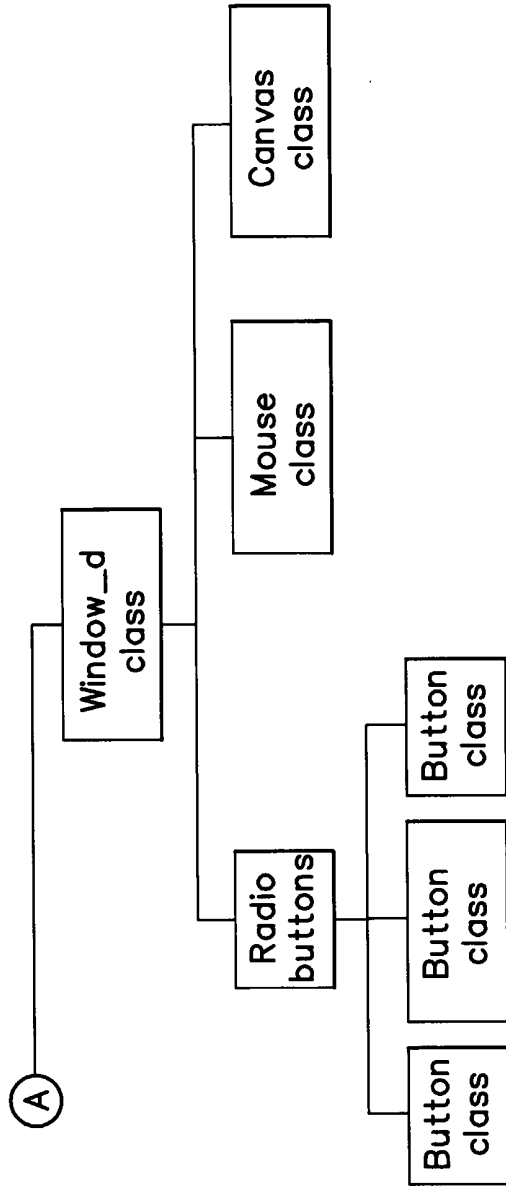

(c) Process Domain

FIG. 28C(2)

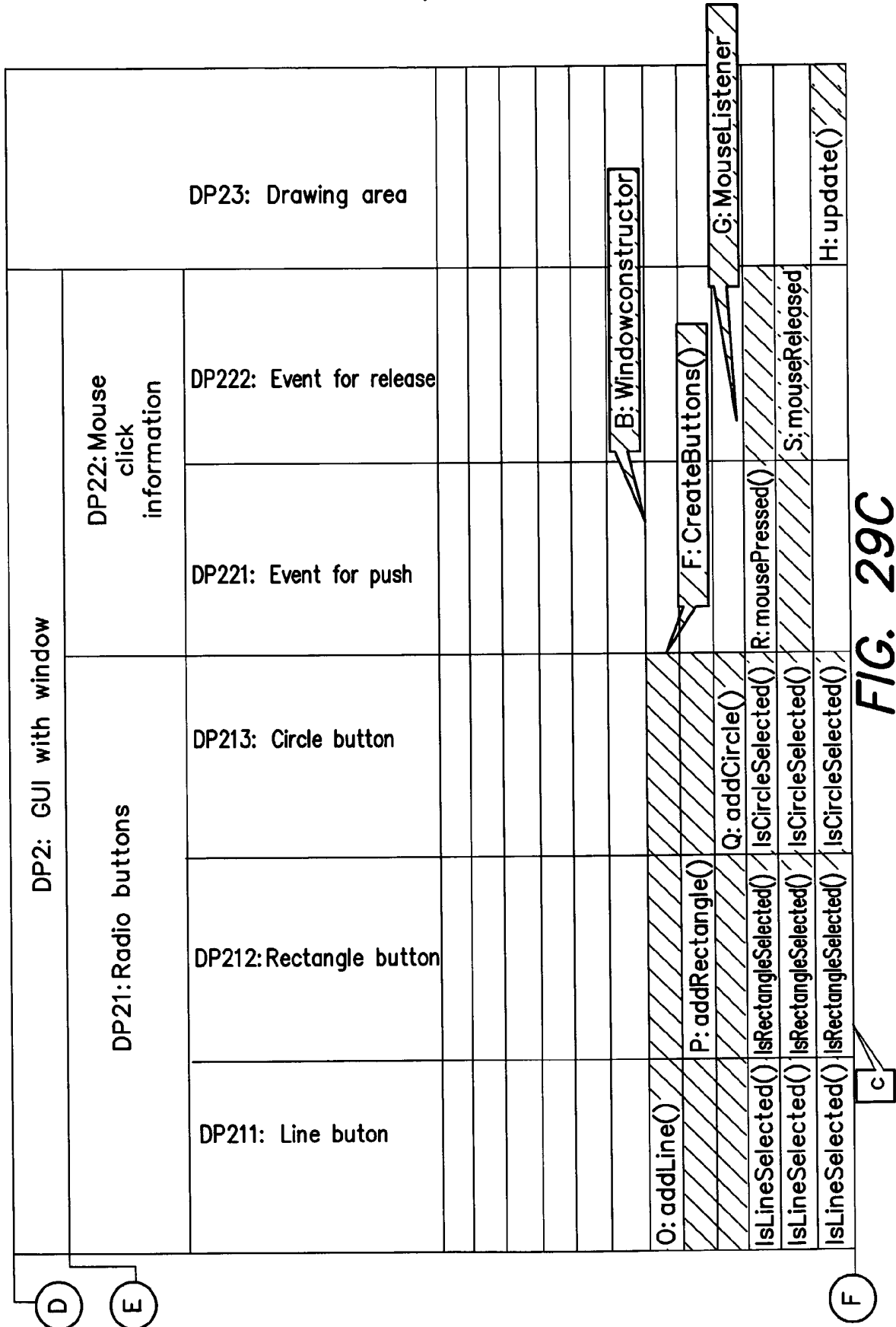

FIG. 29C

Object 1	Object 2	Object 211/212/213	Object 22	Object 23	Object 1*
Element_d	Window_d	RadioBu	Mouse	Canvas	Element_*
DP11	Line l				
DP12	Radiobutton line				
DP13	Radiobutton rectangle				
	Radiobutton circle				
	Mouse m				
	Canvas c				
A	Element()				a Element*()
	Window()				getStart()
	CreateButtons()				getEnd()
	addLine()				getULCorner()
	addRectangle				getLRCorner()
	addCircle()				getCenter()
	implement MouseListener				getRadius()
	mousePressed()				assignLine()
	mouseReleased()				assignRectangle()
	draw()				assignCircle()
	isLineSelected()				
	b/c isRectangleSelected()				
	b/c isCircleSelected()				
	b/c isCircleSelected()				

FIG. 30B

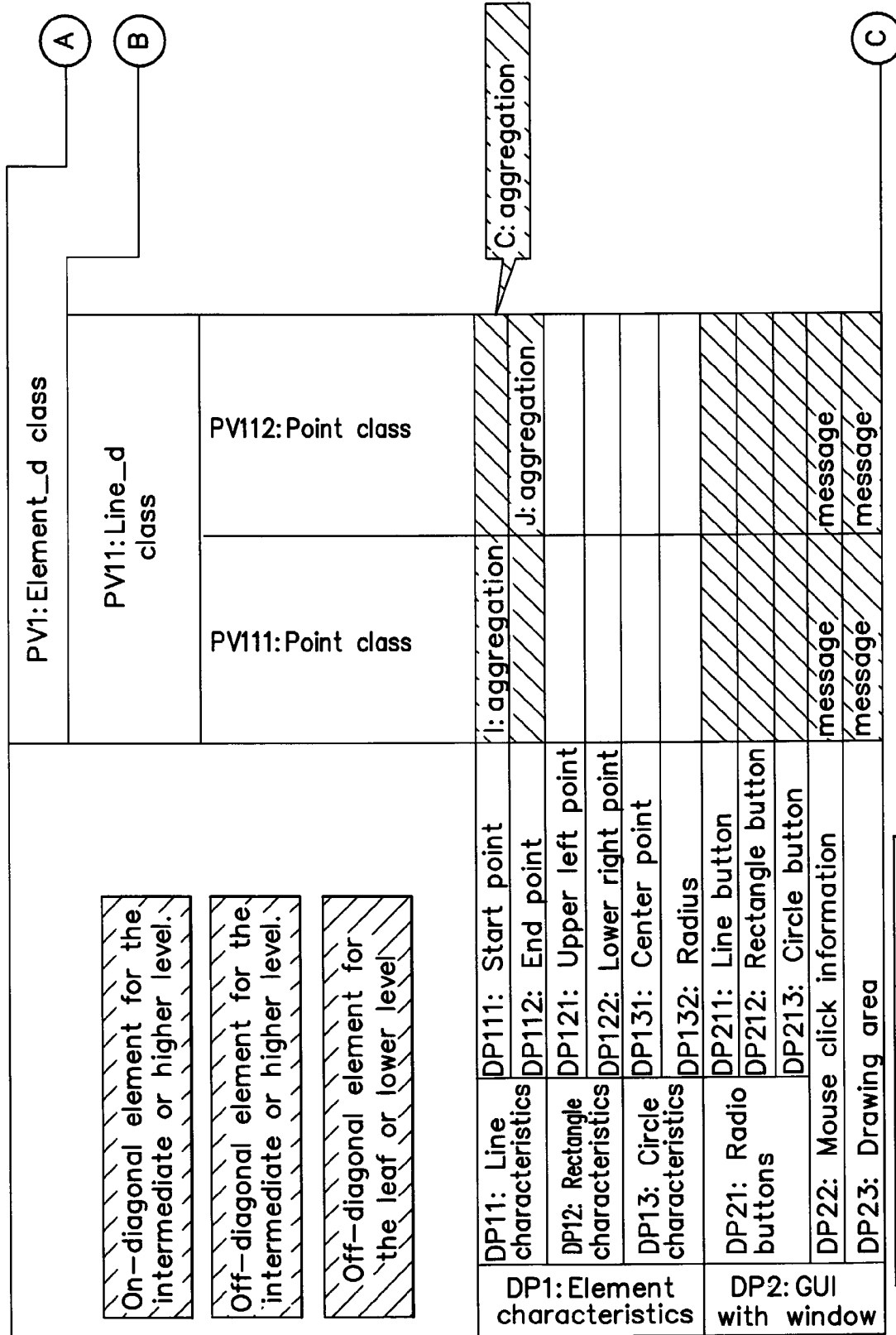

FIG. 31A

FIG. 31A FIG. 31B FIG. 31C

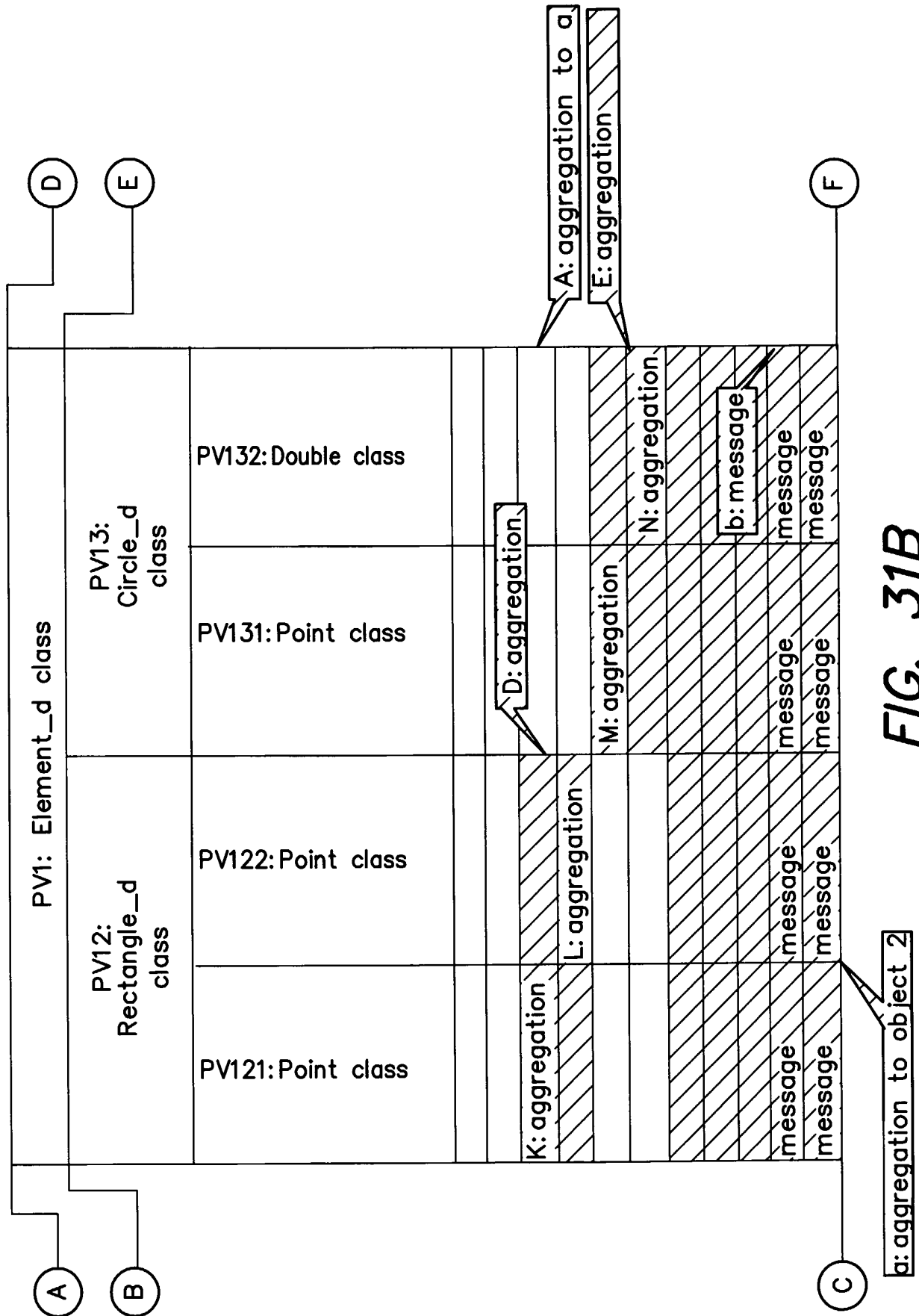

FIG. 31B

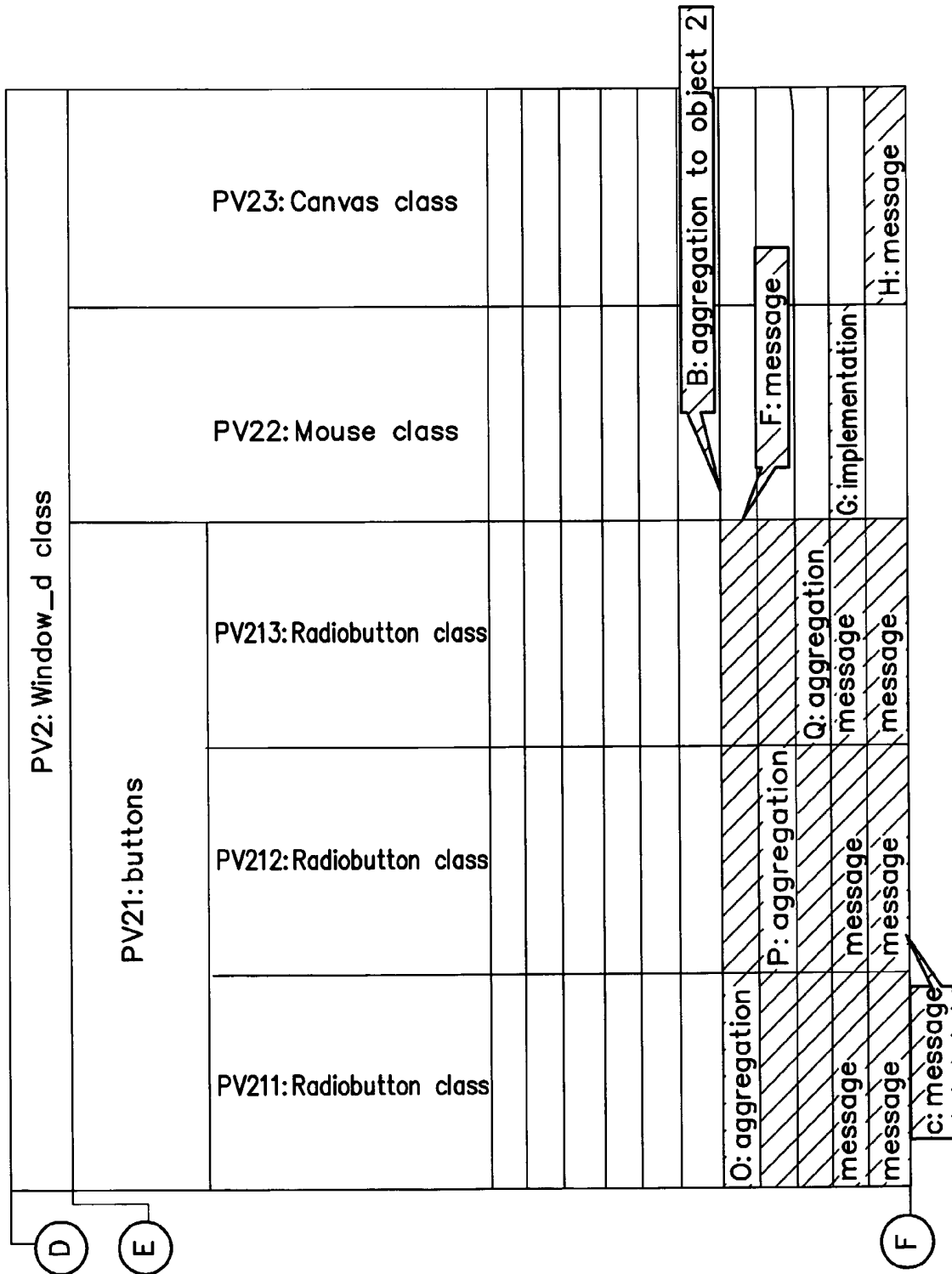

FIG. 31C

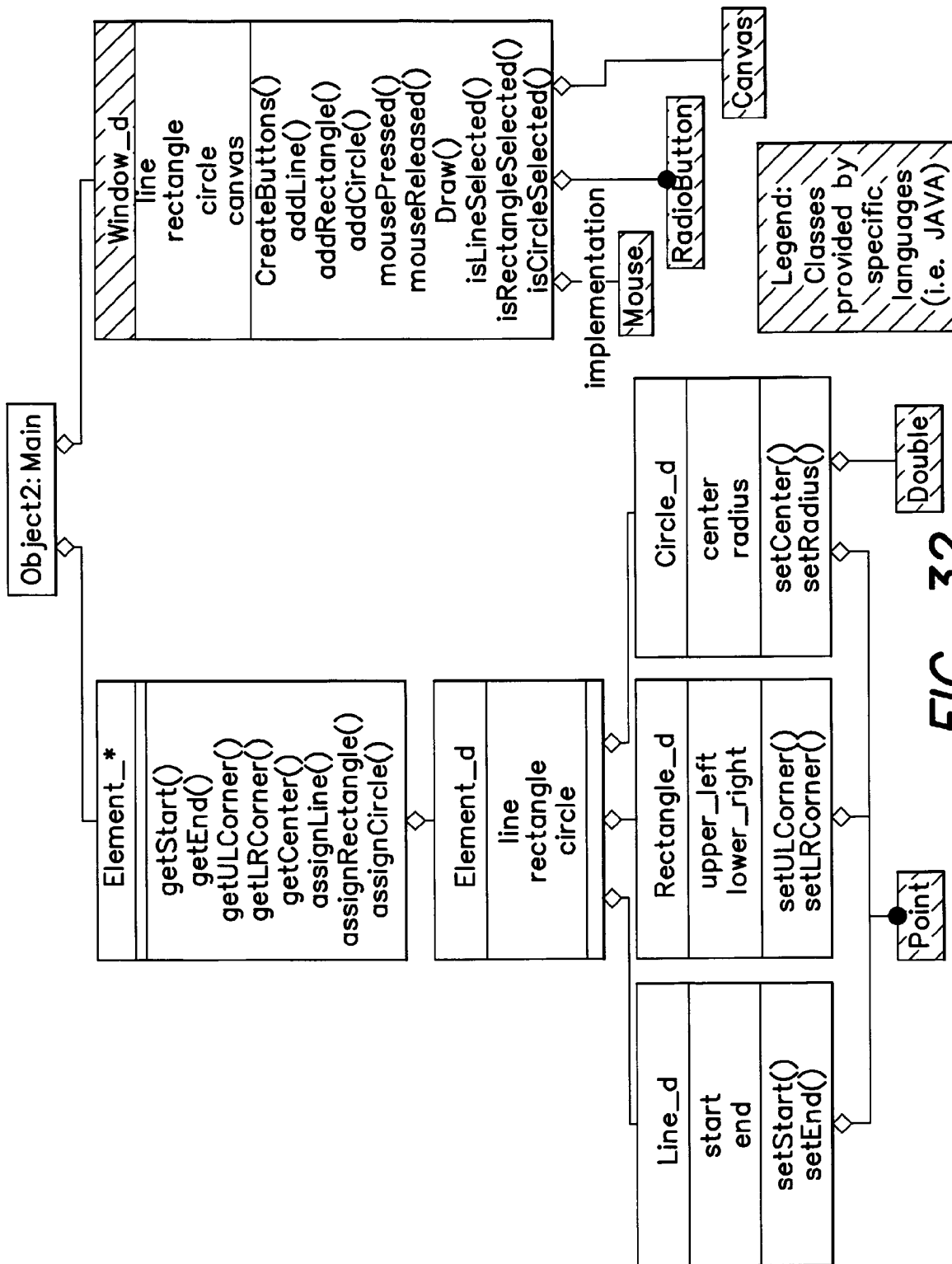

FIG. 32

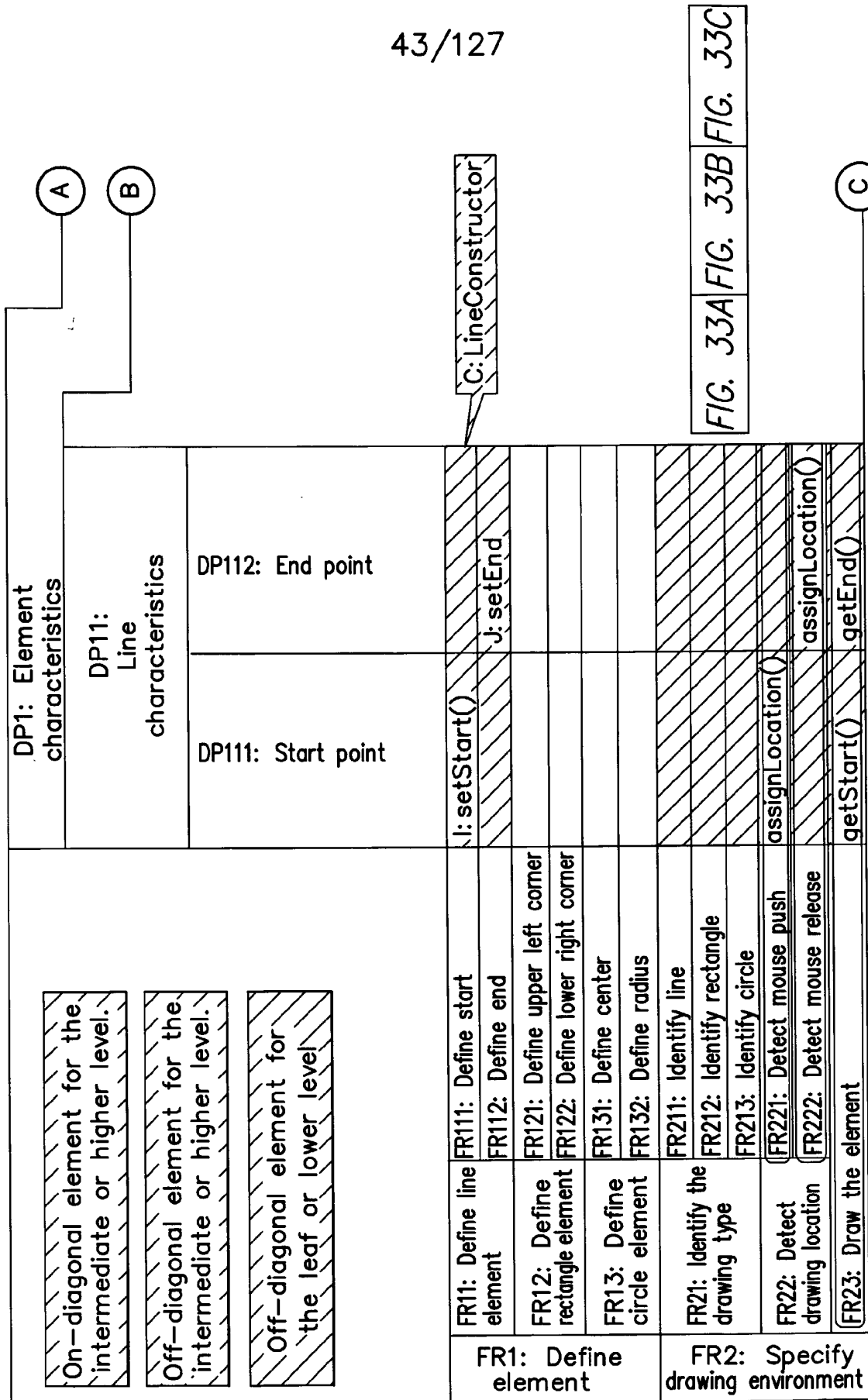

FIG. 33A

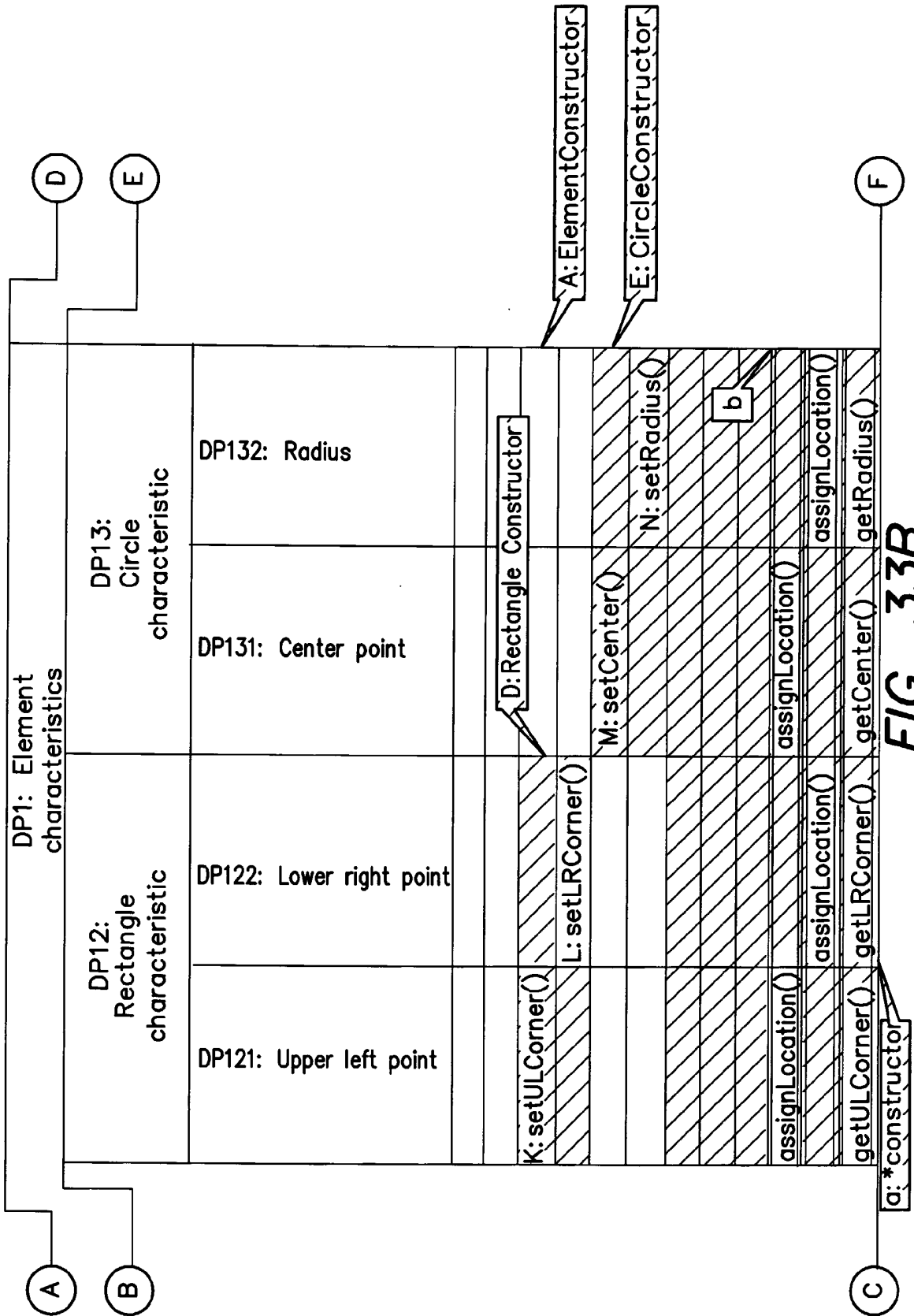

FIG. 33B

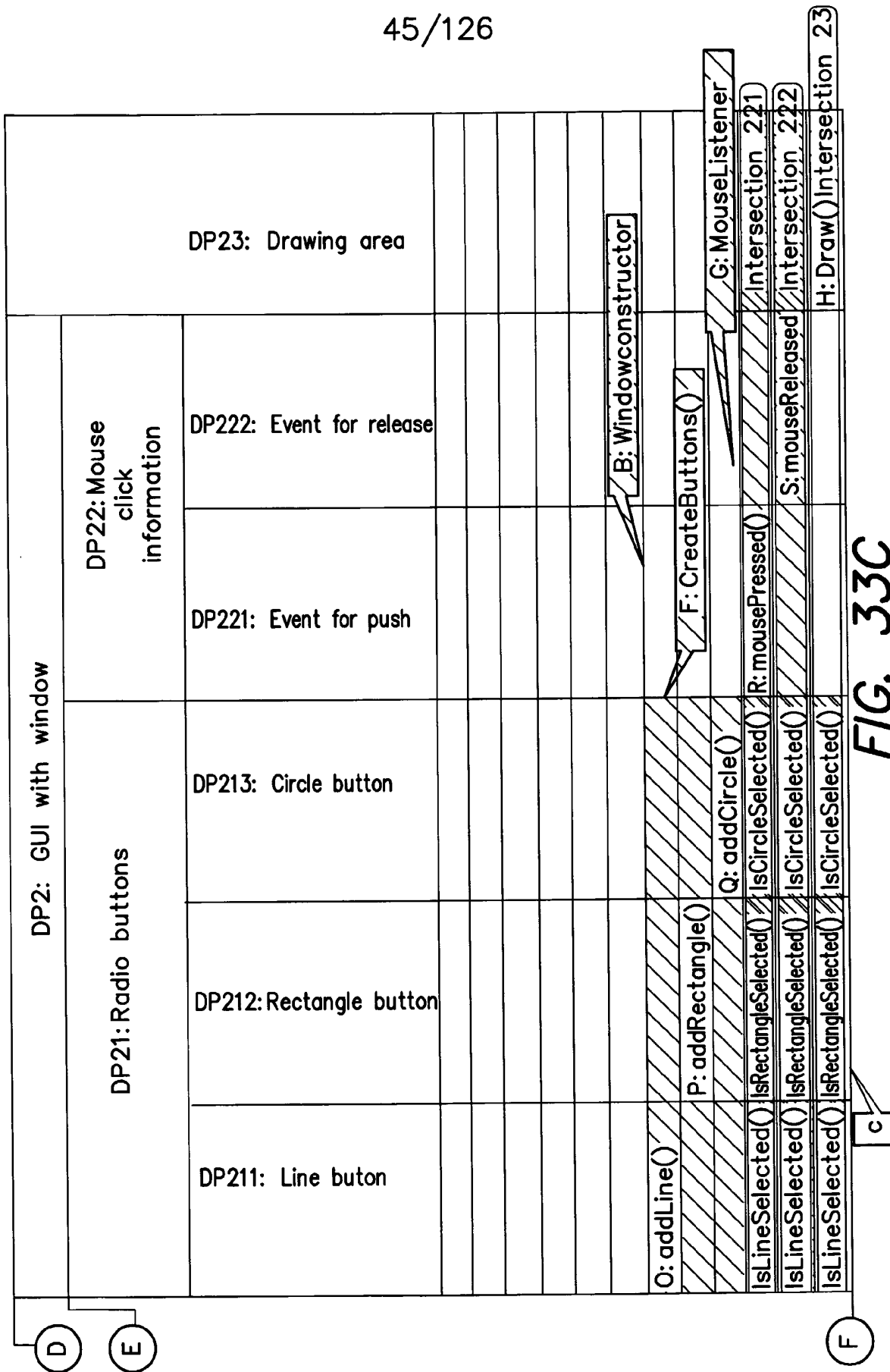

FIG. 33C

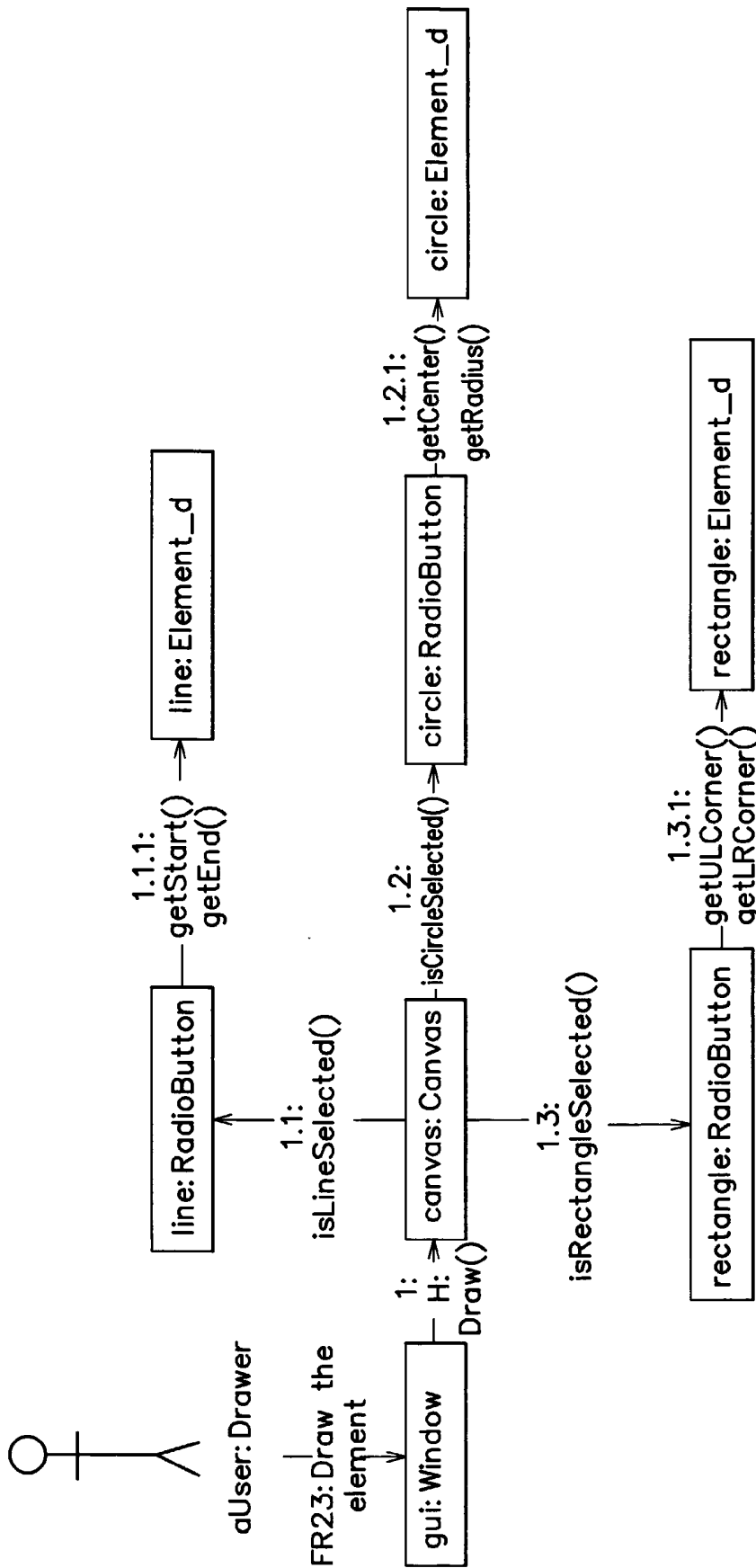

FIG. 34

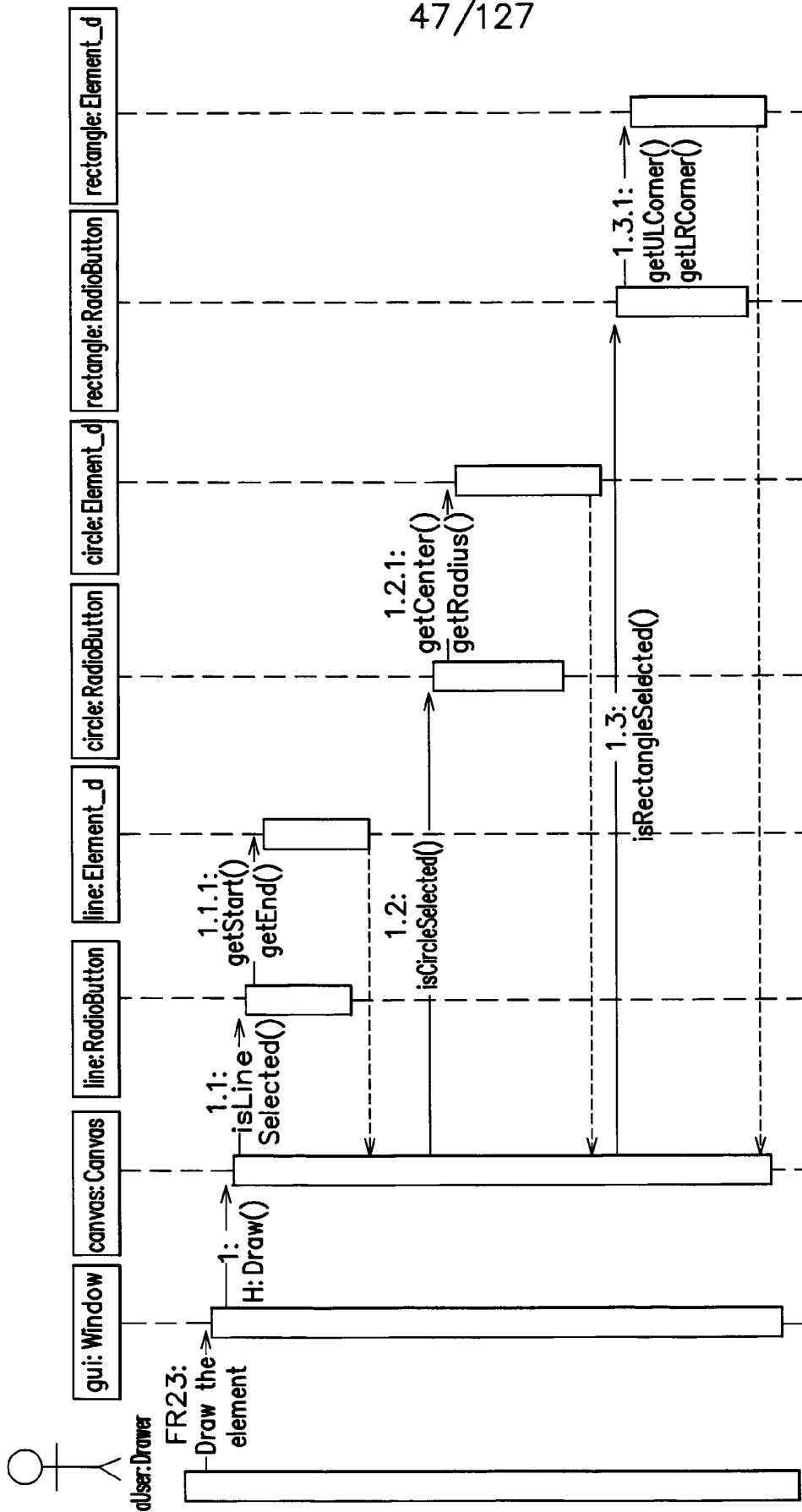

FIG. 35

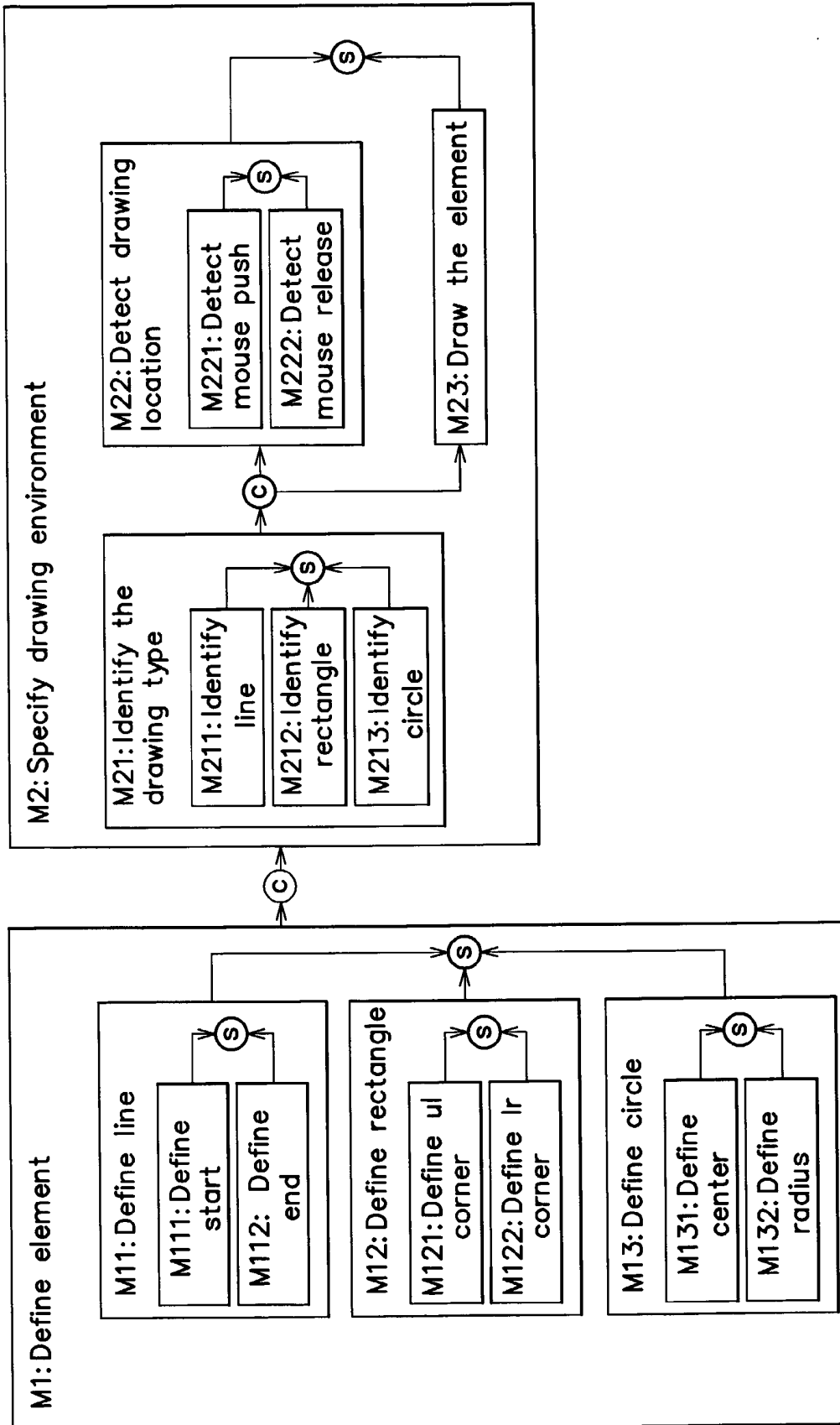

FIG. 36

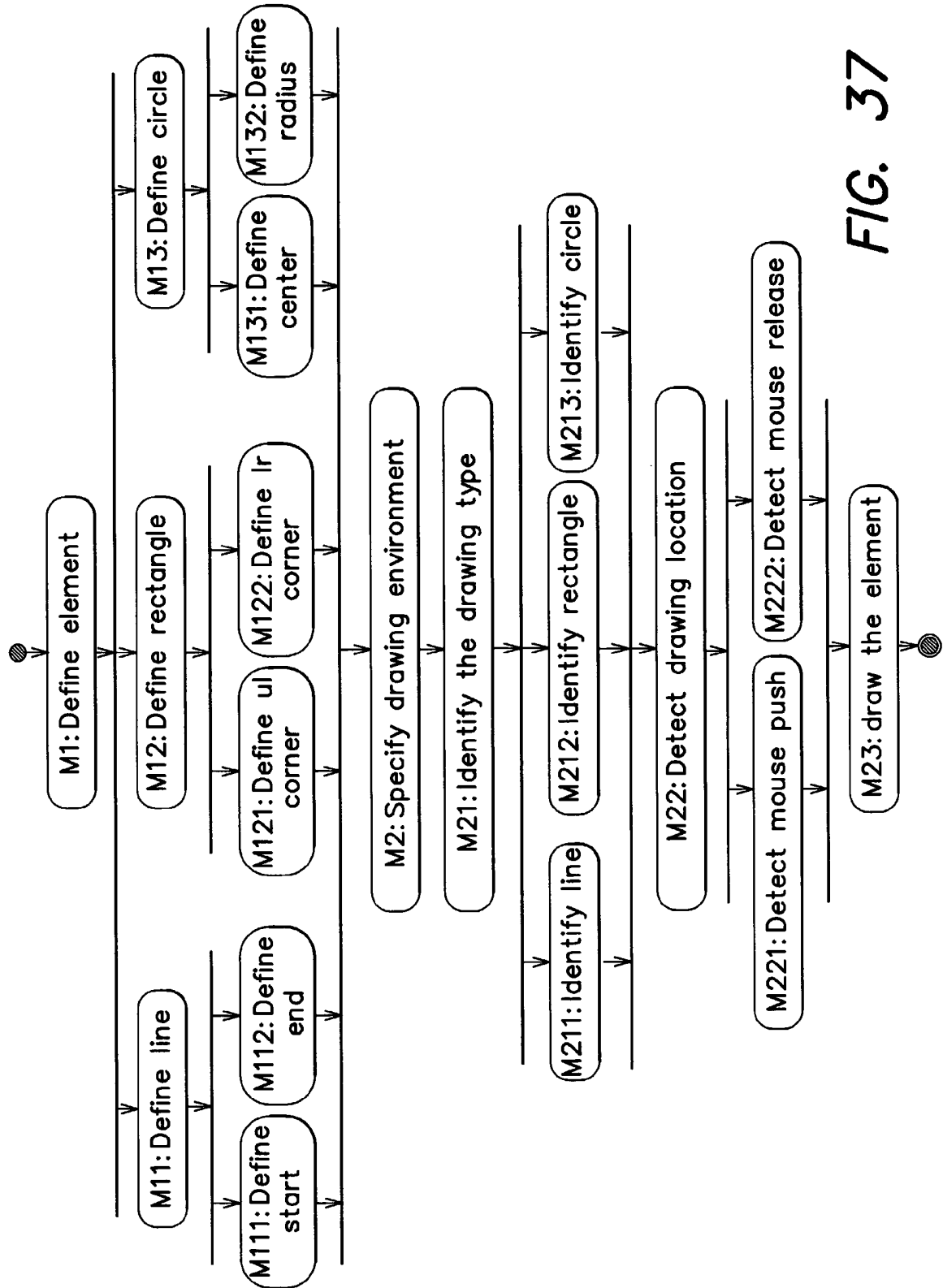

FIG. 37

50/127

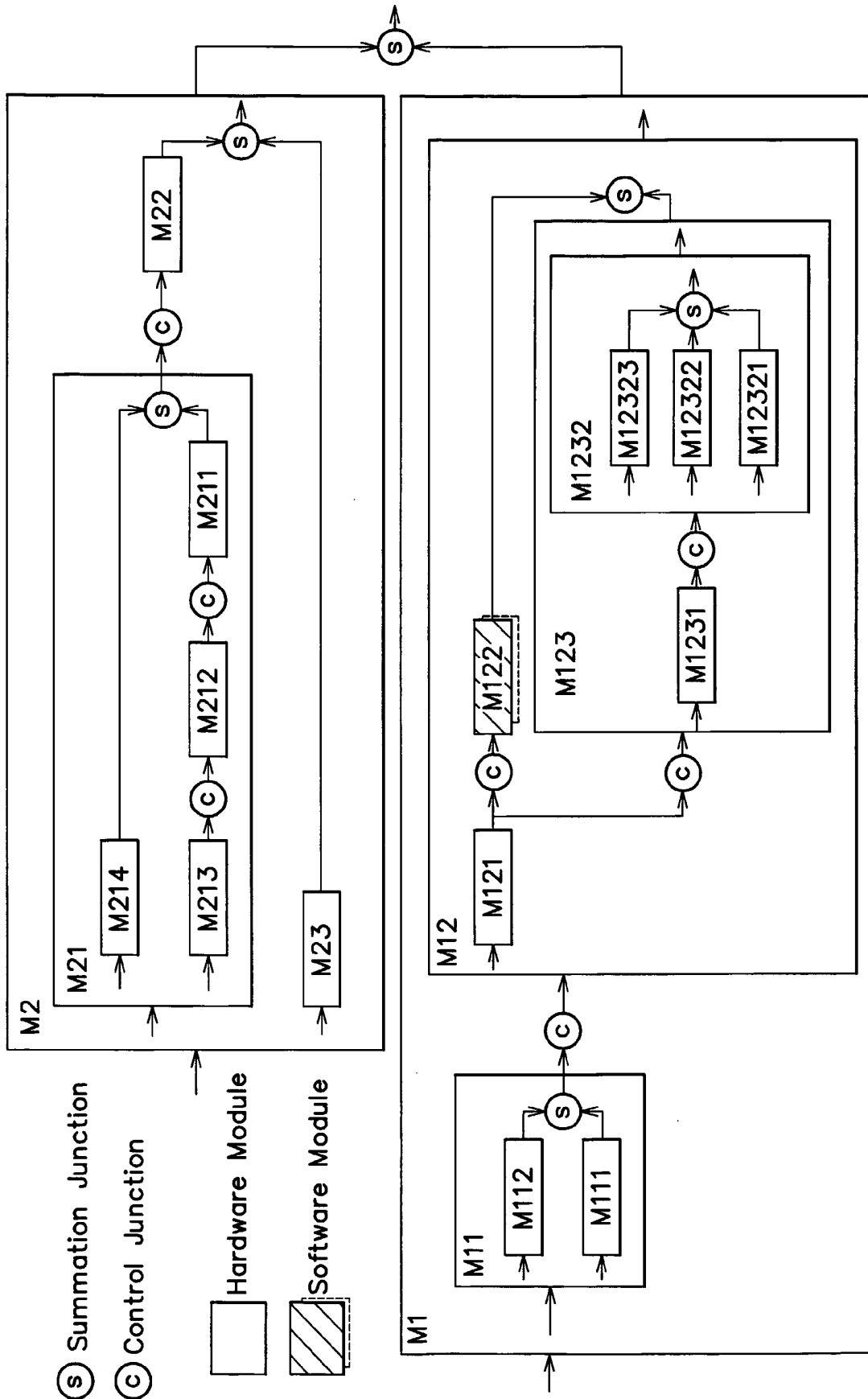

FIG. 38

```

(object Petal
version 40)
(object Design "Logical View"
is_unit TRUE
is_loaded TRUE
file_name "SDATA\\demo1.mdl"
quid "3353F13A0384"
defaults
  (object defaults
rightMargin 0.250000
leftMargin 0.250000
topMargin 0.250000
bottomMargin 0.500000
pageOverlap 0.250000
clipIconLabels TRUE
autoResize TRUE
snapToGrid TRUE
gridX 16
gridY 16
defaultFont (object Font
size 9
face "helvetica"
bold FALSE
italics FALSE
underline FALSE
strike FALSE
color 0
default_color TRUE)

```

FIG. 39A
FIG. 39B

FIG. 39A

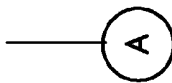
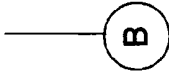

```

root_usecase_package
  showMessageNum 1
  showClassOfObject TRUE
  notation "Unified"
  quid "(object Class_category"UseCaseView"
  exportControl "3353F13A0386"
  global "Public"
  logical_models (list unit_reference_list
    (objectClass"Student"
      quid "3353F162000A"
      documentation "Someone who is registered to take classes at the University"
      stereotype "Actor")
    )

```

FIG. 39B

Code	Parent Number	Number	Description	Keyword	Comment	Category	Verification	Leaf
EX-a	0	1	Define element	--	--	--	--	FALSE
EX-a	0	2	Specify drawing environment	--	--	--	--	FALSE
EX-a	1	1	Define line element	--	--	--	--	FALSE
EX-a	1	2	Define rectangle element	--	--	--	--	FALSE
EX-a	1	3	Define circle element	--	--	--	--	FALSE
EX-a	1.1	1	Define start	--	--	--	--	TRUE
EX-a	1.1	2	Define end	--	--	--	--	TRUE
EX-a	1.2	1	Define upper left corner	--	--	--	--	TRUE
EX-a	1.2	2	Define lower right corner	--	--	--	--	TRUE
EX-a	1.3	1	Define center	--	--	--	--	TRUE
EX-a	1.3	2	Define radius	--	--	--	--	TRUE
EX-a	2	1	Identify the drawing type	--	--	--	--	FALSE
EX-a	2	2	Detect drawing location	--	--	--	--	FALSE
EX-a	2	3	Draw the element	--	--	--	--	TRUE
EX-a	2.1	1	Identify line	--	--	--	--	TRUE
EX-a	2.1	2	Identify rectangle	--	--	--	--	TRUE
EX-a	2.1	3	Identify circle	--	--	--	--	TRUE
EX-a	2.2	1	Detect mouse push	--	--	--	--	TRUE
EX-a	2.2	2	Detect mouse release	--	--	--	--	TRUE

FIG. 40

Code	Parent	Number	Alternative	Description	Keyword	Comment	Category	Verification	Leaf
EX-a	0	1	0	Element characteristics	—	—	—	—	FALSE
EX-a	0	2	0	GUI with window	—	—	—	—	FALSE
EX-a	1	1	0	Line characteristics	—	—	—	—	FALSE
EX-a	1	2	0	Rectangle characteristics	—	—	—	—	FALSE
EX-a	1	3	0	Circle characteristics	—	—	—	—	FALSE
EX-a	1.1	1	0	Start point	—	—	—	—	TRUE
EX-a	1.1	2	0	End point	—	—	—	—	TRUE
EX-a	1.2	1	0	Upper left point	—	—	—	—	TRUE
EX-a	1.2	2	0	Lower right point	—	—	—	—	TRUE
EX-a	1.3	1	0	Center point	—	—	—	—	TRUE
EX-a	1.3	2	0	Radius	—	—	—	—	TRUE
EX-a	2	1	0	Radio buttons	—	—	—	—	FALSE
EX-a	2	2	0	Mouse click information	—	—	—	—	FALSE
EX-a	2	3	0	Drawing area	—	—	—	—	TRUE
EX-a	2.1	1	0	Line button	—	—	—	—	TRUE
EX-a	2.1	2	0	Rectangle button	—	—	—	—	TRUE
EX-a	2.1	3	0	Circle button	—	—	—	—	TRUE
EX-a	2.2	1	0	Event for push	—	—	—	—	TRUE
EX-a	2.2	2	0	Event for release	—	—	—	—	TRUE
DP Table									

(A)

(B)

(C)

(D)

(E)

(F)

(G)

(H)

(I)

(J)

(K)

(L)

(M)

(N)

(O)

(P)

FIG. 41A FIG. 41B

FIG. 41A

	(A)					
Name	Attribute	Type	Description			
Line_d	start	Point	-			
Line_d	end	Point	-			
Rectangle_d	upper_left	Point	-			
Rectangle_d	lower_right	Point	-			
Circle_d	center	Point	-			
Circle_d	radius	Radius	-			
Element_d	line	Line_d	-			
Element_d	rectangle	Rectangle_d	-			
Element_d	circle	Circle_d	-			
Window_d	line	Radiobutton	-			
Window_d	rectangle	Radiobutton	-			
Window_d	circle	Radiobutton	-			
Window_d	mouse	Mouse	-			
Window_d	Canvas	Canvas	-			
				ATTRIBUTE Table	VARIABLE Table	

FIG. 41B

Code1	Code2	Value	Comment	Name	Method	Type	Description
Ex-a.0.1	Ex-a.0.1.0	A	-	Line_d	Line_d()	Line_d	-
Ex-a.0.2	Ex-a.0.1.0	a	-	Line_d	setStart()	void	-
Ex-a.0.2	Ex-a.0.2.0	B	-	Line_d	setEnd()	void	-
Ex-a.1.1	Ex-a.1.1.0	C	-	Rectangle_d	Rectangle_d()	Rectangle_d	-
Ex-a.1.2	Ex-a.1.2.0	D	-	Rectangle_d	setULCorner()	void	-
Ex-a.1.3	Ex-a.1.3.0	E	-	Rectangle_d	setLRCorner()	void	-
Ex-a.2.1	Ex-a.2.1.0	F	-	Circle_d	Circle_d()	Circle_d	-
Ex-a.2.2	Ex-a.2.1.0	b	-	Circle_d	setCenter()	void	-
Ex-a.2.2	Ex-a.2.2.0	G	-	Circle_d	setRadius()	void	-
Ex-a.2.3	Ex-a.2.1.0	c	-	Element_d	Element_d()	Element_d	-
Ex-a.2.3	Ex-a.2.3.0	H	-	Window_d	Window_d()	Window_d	-
Ex-a.1.1.1	Ex-a.1.1.1.0	I	-	Window_d	CreateButtons()	void	-
Ex-a.1.1.2	Ex-a.1.1.2.0	J	-	Window_d	addLine()	void	-
Ex-a.1.2.1	Ex-a.1.2.1.0	K	-	Window_d	addRectangle()	void	-
Ex-a.1.2.2	Ex-a.1.2.2.0	L	-	Window_d	addCircle()	void	-
Ex-a.1.3.1	Ex-a.1.3.1.0	M	-	Window_d	MouseListener()	void	-
Ex-a.1.3.2	Ex-a.1.3.2.0	N	-	Window_d	mousePressed()	Point	-
Ex-a.2.1.1	Ex-a.2.1.1.0	O	-	Window_d	mouseReleased()	Point	-
Ex-a.2.1.2	Ex-a.2.1.2.0	P	-	Window_d	draw()	void	-
Ex-a.2.1.3	Ex-a.2.1.3.0	Q	-	Window_d	isLineSelected()	boolean	-
Ex-a.2.2.1	Ex-a.2.2.1.0	R	-	Window_d	isRectangleSelected()	boolean	-
Ex-a.2.2.2	Ex-a.2.2.2.0	S	-	Window_d	isCircleSelected()	boolean	-

FIG. 42A
FIG. 42B

(C)

(B)

(A)

FIG. 42A

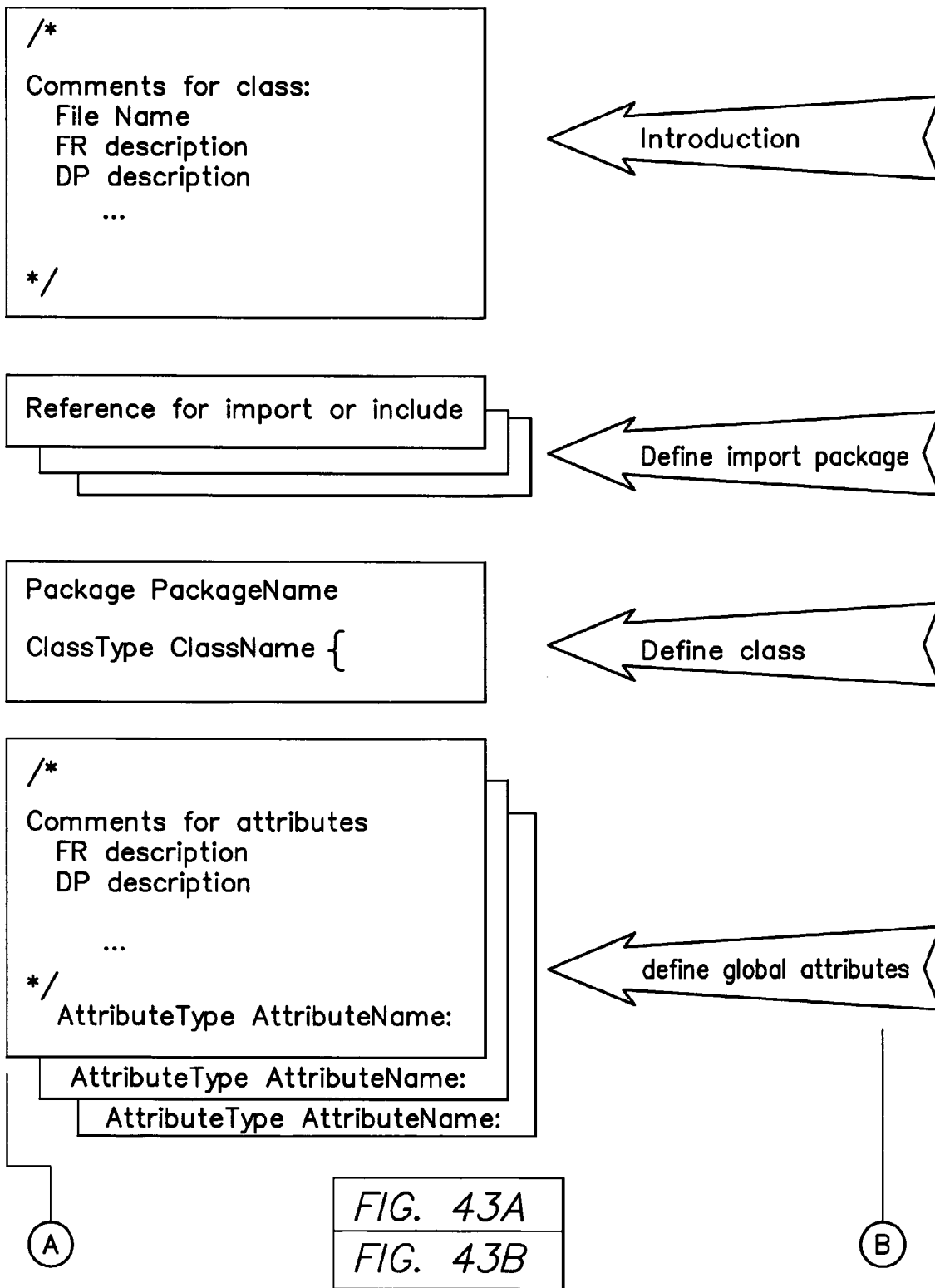

FIG. 43A

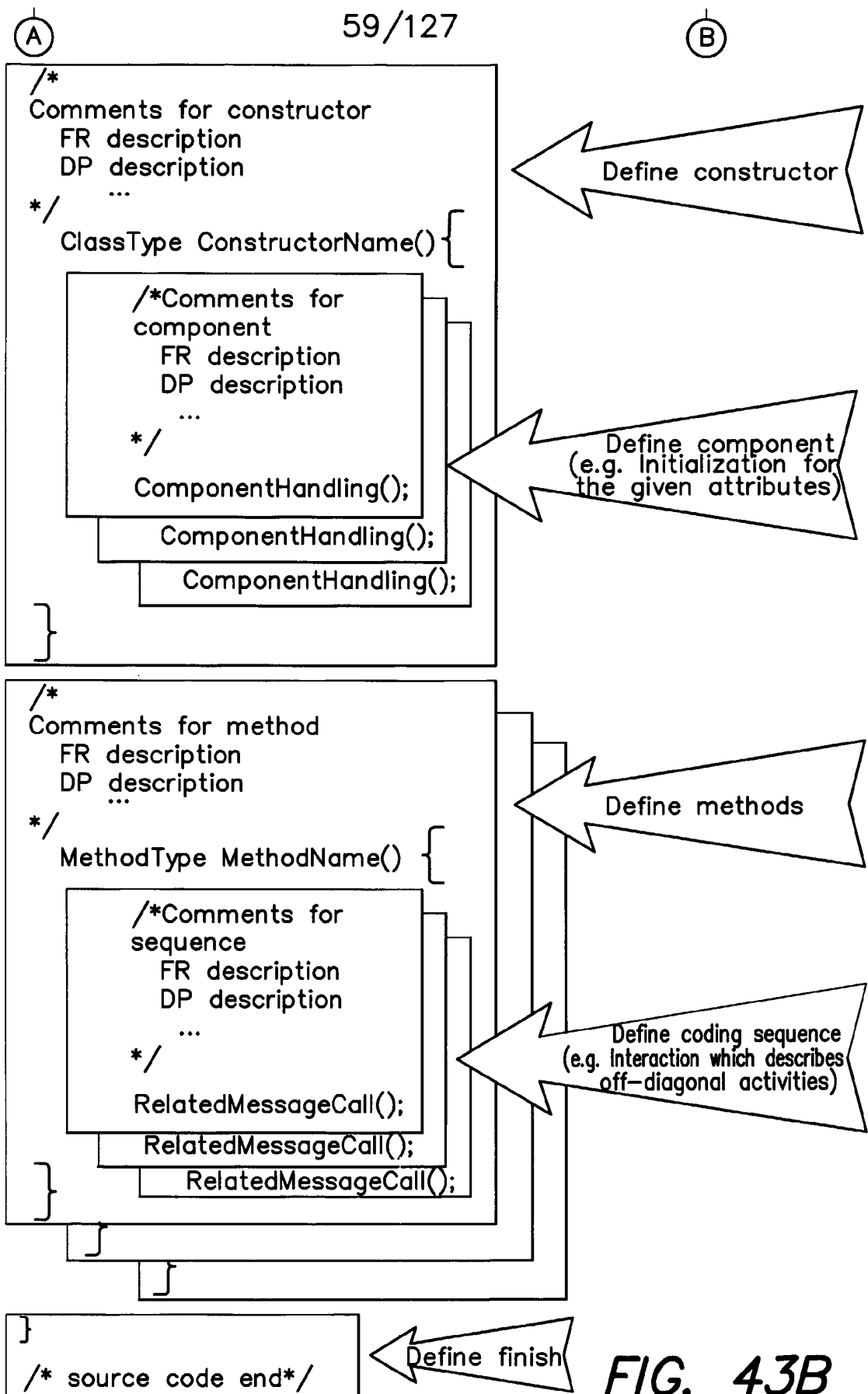

FIG. 43B

```

/*
Comments for class:
File Name
FR description
DP description
...
*/

```

```

/*
Coments for class:
File Name: Window_d.java
FR2: Specify drawing environment
DP2: GUI with window
FR2=a*DP1(Element
characteristic)+B*DP2(GUI
with window)
*/

```

Reference for import or include

```

import javax.swing.*;
import java.awt.*;

```

```

Package PackageName
ClassType ClassName {

```

```

public class window_d { /*DP2*/

```

```

/*
Comments for attributes
FR description
DP description
...
*/
AttributeType AttributeName;

```

```

/* Comments for attributes:
FR211: Identify line
DP211: Line button */
Radiobutton line; /*DP211*/

/* Comments for attributes:
FR212: Identify rectangle
DP212: Rectangle button */
Radiobutton rectangle; /*DP212*/
...

```

```

AttributeType AttributeName;
AttributeType AttributeName;

```

A

FIG. 44A
FIG. 44B
FIG. 44C

B

FIG. 44A

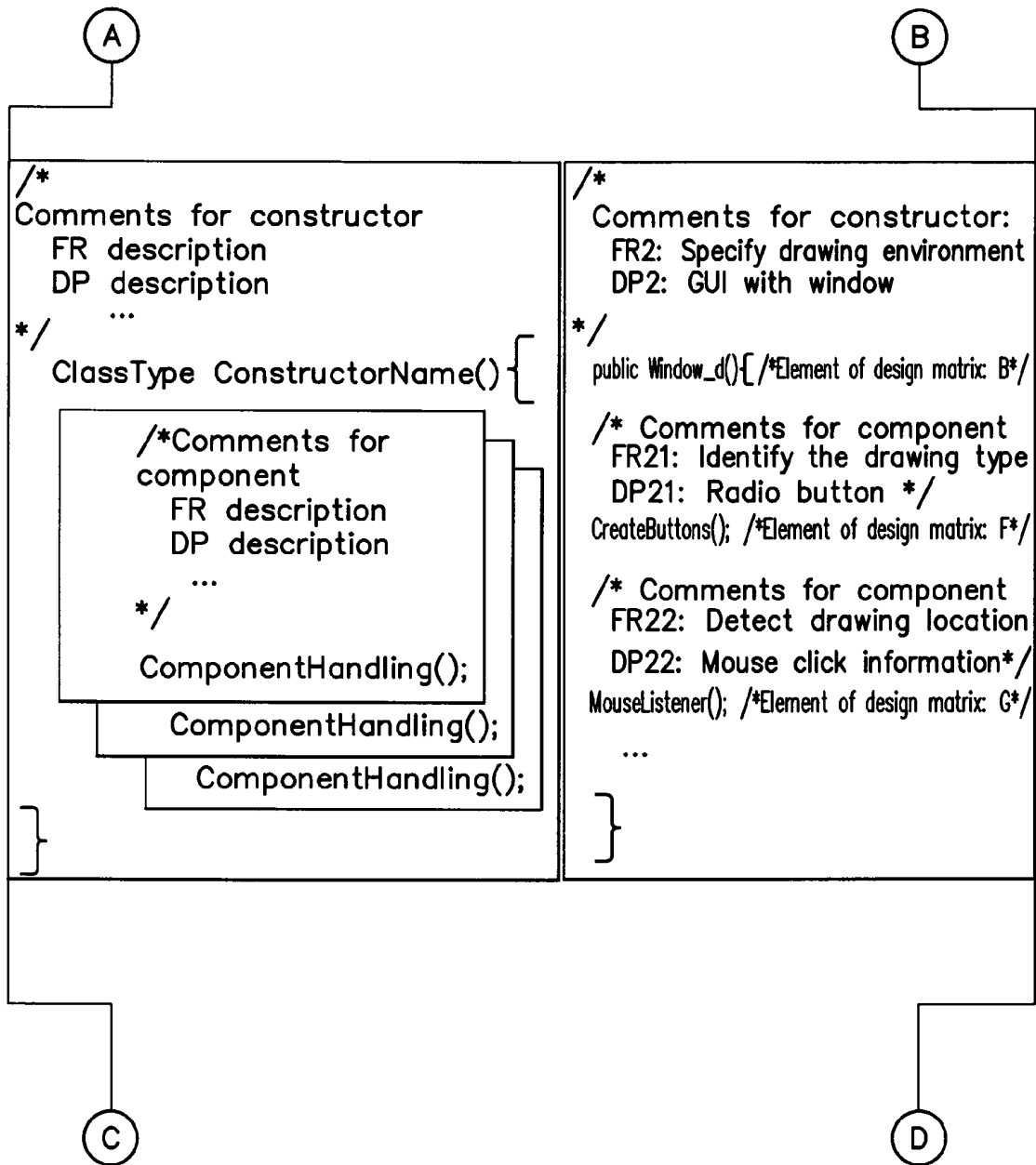

FIG. 44B

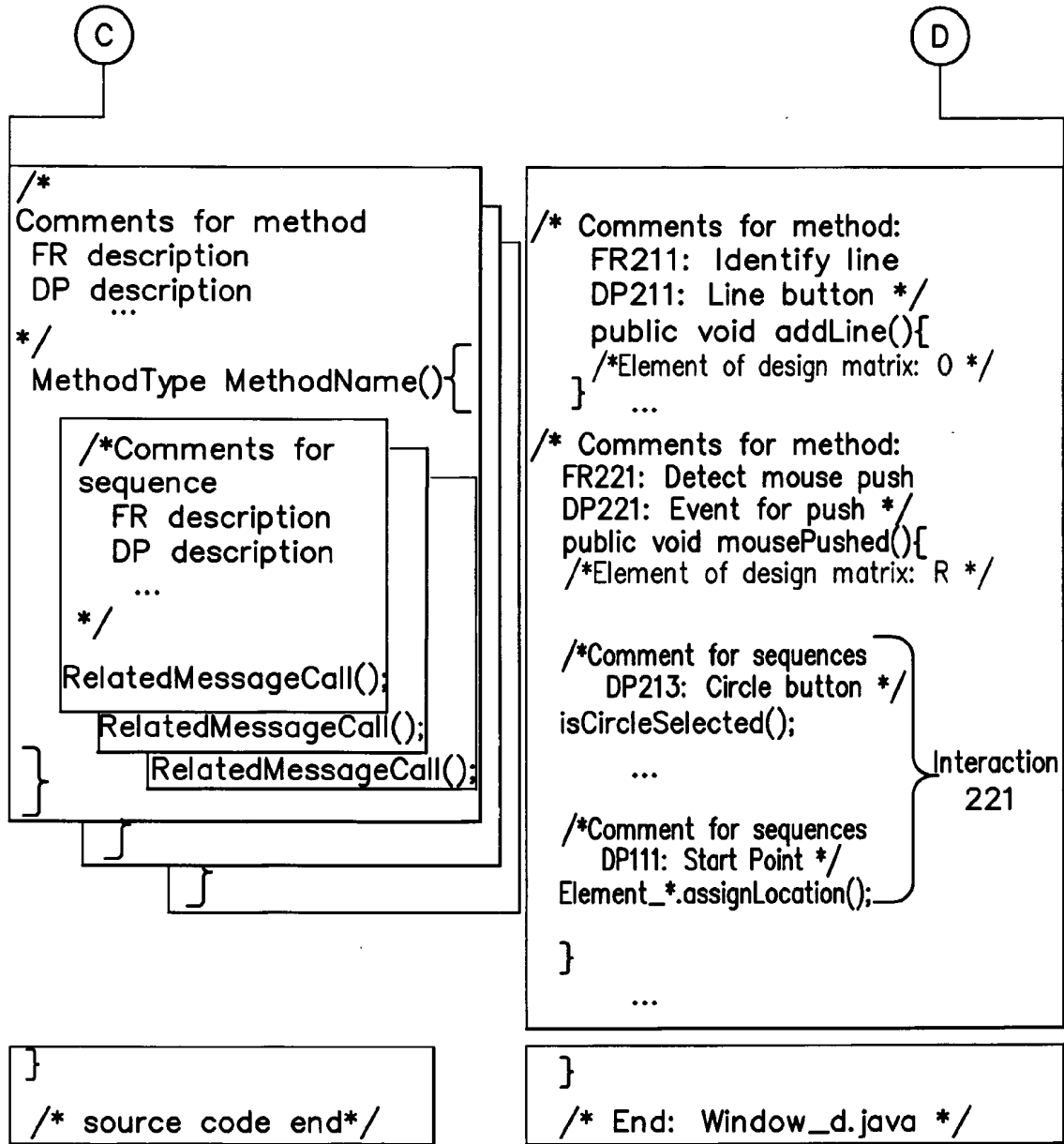

FIG. 44C

63/127

FR Information:		DP Information:	
Number	Description	Num...	Description
FR#.1	Provide security	DP#.1	Login privilege
FR#.2	Assign tasks	DP#.2	Resource of desig...
FR#.3	Manage schedule	DP#.3	Schedule-manage...
FR#.4	Construct design h...	DP#.4	Data structure for...
FR#.5	Facilitate changes...	DP#.5	ECO handling tool

FIG. 45A

	FR	DP
1	FR 1 description	DP 1 description
2	FR 2 description	DP 2 description
3	FR 3 description	DP 3 description

FIG. 45B

64/127

FR Information:		DP Information:	
Number	Description	Number	Description
FR#.1	Control the water fl...	DP#.1	Angle for flow ra...
FR#.2	Control the temper...	DP#.1(1)	Angle of hot wat...
		DP#.2	Angle for tempe...
		DP#.2(1)	Connecting rod...
		DP#.2(2)	Angle of cold w...

FIG. 46A

	FR	DP
1	FR 1 description	DP 1 description
2	FR 2 description	Alternative DP 2(a)
		Alternative DP 2(b)
		Alternative DP 2(c)
3	FR 3 description	DP 3 description

FIG. 46B

65/127

Parent Information:	
Number	Description
FR 1.1	Manage design workflow
DP 1.1	Management roadmap

FR Information:		DP Information:	
Number	Description	Number	Description
FR#.1	Provide security	DP#.1	Login privilege
FR#.2	Assign tasks	DP#.2	Resource of de...
FR#.3	Manage schedule	DP#.3	Schedule-mana...
FR#.4	Construct design h...	DP#.4	Data structure f...
FR#.5	Facilitate changes...	DP#.5	ECO handling t...

FIG. 47A

	FR	DP
Parent	Parent FR description	Parent DP description
1	FR 1 description	DP 1 description
2	FR 2 description	Alternative DP 2(a)
		Alternative DP 2(b)
		Alternative DP 2(c)
3	FR 3 description	DP 3 description

FIG. 47B

66/127

Parent Information:			
Number	Description		
FR 1.1	Manage design workflow		
DP 1.1	Management roadmap		

FR Information:		DP Information:	
Number	Description	Number	Description
FR#.1	Provide security	DP#.1	Login privilege
FR#.2	Assign tasks	DP#.2	Resource of de...
FR#.3	Manage schedule	DP#.3	Schedule-mana...
FR#.4	Construct design h...	DP#.4	Data structure f...
FR#.5	Facilitate changes...	DP#.5	ECO handling t...

FIG. 48A

#:	1.2.3	FR	DP
Parent	Parent FR description	Parent DP description	
#.1	FR 1 description	DP 1 description	
#.2	FR 2 description	Alternative DP 2(a)	
		Alternative DP 2(b)	
		Alternative DP 2(c)	
#.3	FR 3 description	DP 3 description	

FIG. 48B

Constraint Information:

Num...	Descr...	FR#1	FR#2	FR#3	FR#4	FR#5
C#1	Make...	X	X	X	X	X
C#2	Supp...	X	X	X	X	X
C#3	Elimi...	X	X	X	X	X
C#4	Facilit...	X	X	X	X	X
C#5	Funct...					
C#6	Obie...					

FIG. 49A

Mapping		Constraints			Robust Design		Analysis	
Index	Category	Type	Constraints	Comments	Operator	Target	Calculated	
1	Critical	Marke	Weight	<input checked="" type="checkbox"/>	Less than (<+)	300lb		
2	Interface	Field	Cost	<input type="checkbox"/>	More than (>=)	\$500		
3	Project	Manu	Volume	<input checked="" type="checkbox"/>	Exact (=+/-)	10cu		

FR#	C#1	C#2	C#3	CA's
FR#1	X			<input checked="" type="checkbox"/>
FR#2	X	X		<input type="checkbox"/>
FR#3	X		X	<input type="checkbox"/>
FR#4	X			<input checked="" type="checkbox"/>

FIG. 49B

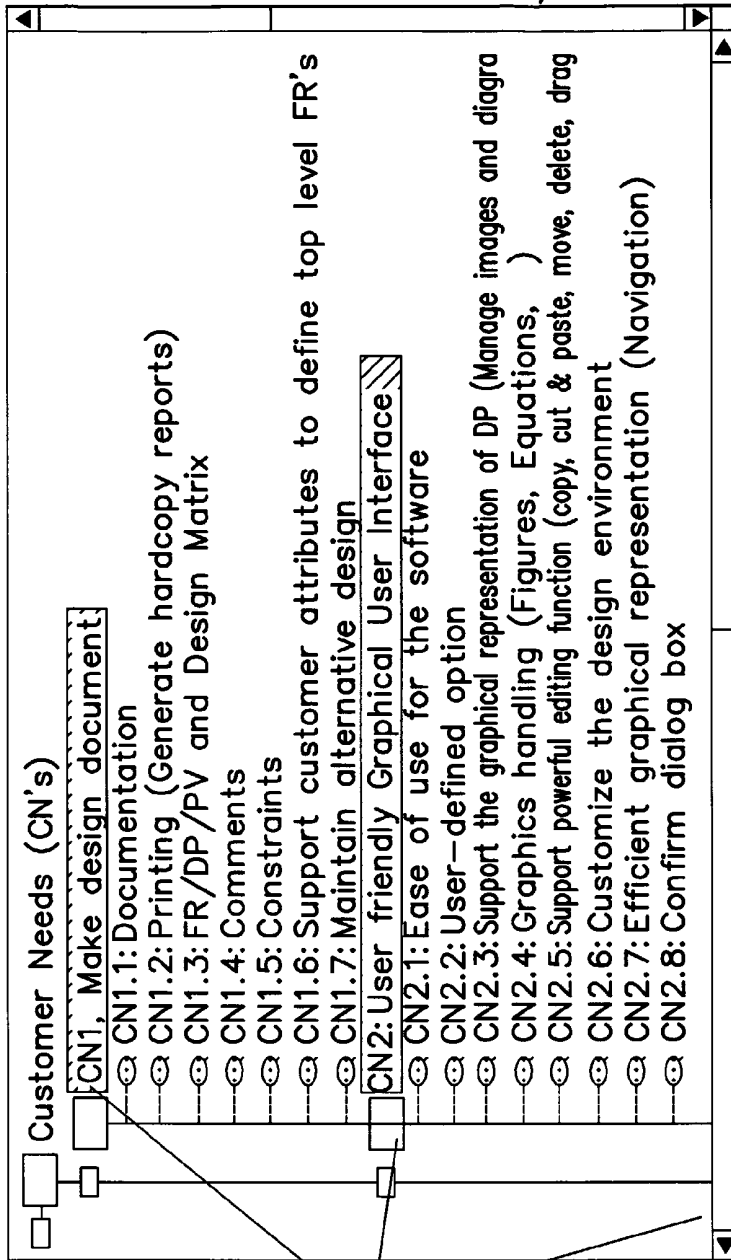

	C#.1	C#.2	C#.3	CA's
FR#.1	X			<input checked="" type="checkbox"/>
FR#.2	X	X	X	<input type="checkbox"/>
FR#.3	X		X	<input type="checkbox"/>
FR#.4	X			<input checked="" type="checkbox"/>

FIG. 50

Index #	Information			Target Value			
	Category	Type	Constraints	Comments	Operator	Target	Calculated
1	Critical	Marke	Weight	<input checked="" type="checkbox"/>	Less than (<+)	300lb	
2	Interface	Field	Cost	<input type="checkbox"/>	More than(>=)	\$500	
3	Project	Manu	Volume	<input checked="" type="checkbox"/>	Exact (+=/-)	10cu	

FIG. 51

The screenshot shows a dialog box titled "Edit Functional Requirements" with a standard window control bar (minimize, maximize, close). The dialog contains the following text and controls:

- Text: "The Current Functional Requirement is:"
- Text: "Please start with VERB for description."
- Text: "Data Input" followed by a large empty text area.
- Text: "Description:" followed by a text box containing "Support user friendliness of the software."
- Text: "Keyword:" followed by a text box containing "User friendly".
- Text: "Comment:" followed by a text box containing "The GUI is one of the most important features of the AD software. The design of the GUI will be discussed later."
- Text: "Template:" followed by a dropdown menu showing "Process".
- Text: "Verification:" followed by a dropdown menu showing "Testing".
- Text: Clean
- Buttons: "Process", "Append", "Change", "Delete", "Cancel", "Insert", "Clean", "Verification: Testing", "Template: Process".

FIG. 52A

Parent Information		
Nu...	Description	Comment
FR 1	Make a decision-making tool whi...	A software tool for decision maki...
DP 1	Computerized system with the A...	Software for Axiomatic Design.

FR Information:		
Num...	Description	Comment
FR#1	Manage desi...	The design a...
FR#2	Provide decis...	The FR deal...
FR#3	Support user...	The GUI is a...
FR#4	Provide effici...	All kinds of d...
FR#5	Provide utility...	The fundam...

DP Information:		
Num...	Description	Comm...
DP#1	Management ro...	
DP#2	Decision-maki...	
DP#3	Graphical User...	
DP#4	Data-managing...	
DP#5	Plug-in software	

FIG. 52B

Index #	Template	Information		Comment		App. Link
		FR	DP	FR	DP	
Parent		Control the FR/DP domain	FR/DP window	<input checked="" type="checkbox"/>	<input type="checkbox"/>	
1		Control the mapping	Mapping tab	<input checked="" type="checkbox"/>	<input checked="" type="checkbox"/>	
2		Assign constraints	Domain tab	<input type="checkbox"/>	<input checked="" type="checkbox"/>	
3		Refine the design	Constraints tab	<input type="checkbox"/>	<input type="checkbox"/>	
4		Analyze the design	Robust design tab	<input checked="" type="checkbox"/>	<input type="checkbox"/>	
			Analysis tab	<input checked="" type="checkbox"/>	<input checked="" type="checkbox"/>	

FIG. 52C

72/127

			DP1						DP2				
			DP11	DP12	DP13	DP21	DP22	DP23	DP24	DP25	DP26		
FR1	FR11	FR111	X	/									
		FR112	/	X									
	FR12	FR121		X	/								
		FR122		/	X								
	FR13	FR131				X	/						
		FR132				/	X						
FR2	FR21	FR211	/	/	/	/	X	/	/				
		FR212	/	/	/	/	/	X	/				
		FR213	/	/	/	/	/	/	X	/			
	FR22	FR221	X	X	X	X	X	X	X	X			
		FR222	X	X	X	X	X	X	X	X	X		
	FR23		X	X	X	X	X	X	X	X	X		

FIG. 53

73/127



 FR/DP	 Design Matrix	 Analysis
Parent Information:		
Number	Description	
FR 1.1	Manage design workflow	
DP 1.1	Management roadmap	
FR Information:		DP Information:
Numb...	Description	Numb... Description
FR#.1	Provide security	DP#.1 Login privilege
FR#.2	Assign tasks	DP#.2 Resource of d...
FR#.3	Manage Sched...	DP#.3 Schedule-ma...
FR#.4	Construct desi...	DP#.4 Data structure...
FR#.5	Facilitate chan...	DP#.5 ECO handling...

FIG. 54A



 FR/DP	 Design Matrix	 Analysis			
Design Matrix Table:					
A1.1(1.1)	DP#.1	DP#.2	DP#.3	DP#.4	DP#.5
FR#.1	X	0	0	0	0
FR#.2	X	X	0	0	X
FR#.3	X	X	X	0	X
FR#.4	X	0	0	X	X
FR#.5	X	0	0	0	X

FIG. 54B

Mapping		Constraints		Robust Design		Analysis		
Index #	Parent	Information		Comment		FR	DP	App. Link
		FR	DP	FR	DP			
Alt. 1		Control the FR/DP domain	FR/DP window	<input checked="" type="checkbox"/>	<input type="checkbox"/>	<input checked="" type="checkbox"/>	<input type="checkbox"/>	
Alt. 2		Control the mapping	Mapping tab Domain tab	<input checked="" type="checkbox"/>	<input checked="" type="checkbox"/>	<input type="checkbox"/>	<input checked="" type="checkbox"/>	
Alt. 3		Assign constraints	Constraints tab	<input type="checkbox"/>	<input type="checkbox"/>	<input type="checkbox"/>	<input type="checkbox"/>	
Alt. 4		Refine the design	Robust design tab	<input checked="" type="checkbox"/>	<input type="checkbox"/>	<input checked="" type="checkbox"/>	<input type="checkbox"/>	
		Analyze the design	Analysis tab	<input checked="" type="checkbox"/>	<input checked="" type="checkbox"/>	<input checked="" type="checkbox"/>	<input checked="" type="checkbox"/>	

	DP#1	DP#2(a)	DP#2(b)	DP#3	DP#4
FR#1	X				
FR#2	X	X			
FR#3	X		X		
FR#4	X		X	X	X

FIG. 54C

75/127

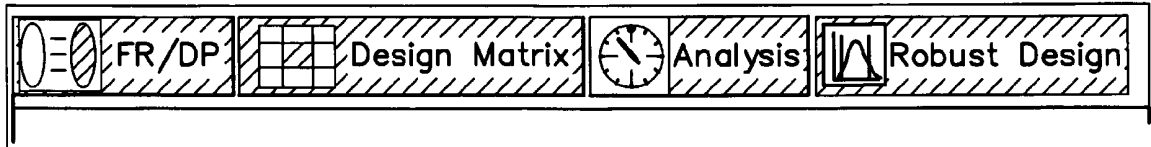

FIG. 55A



FIG. 55B

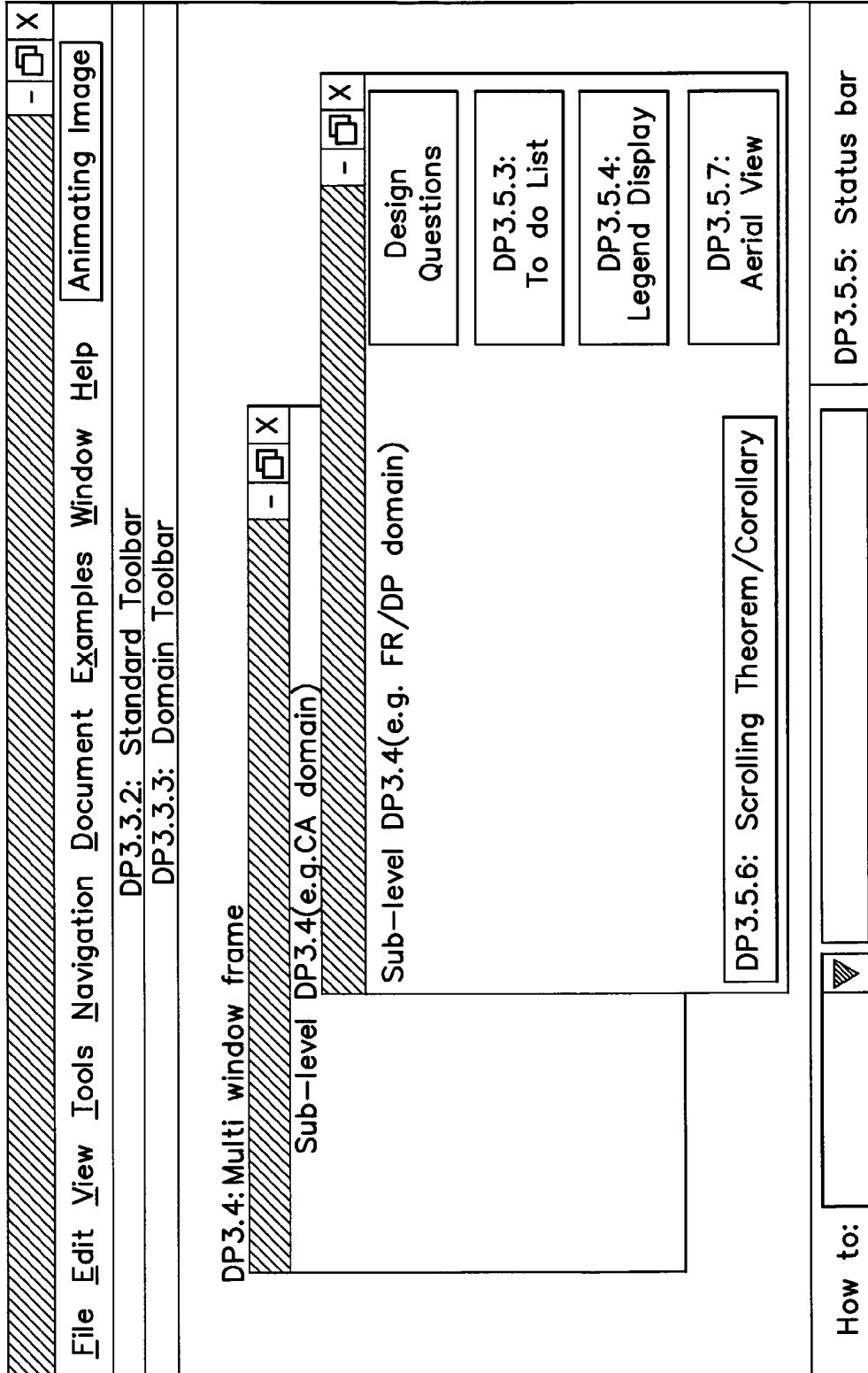

FIG. 56

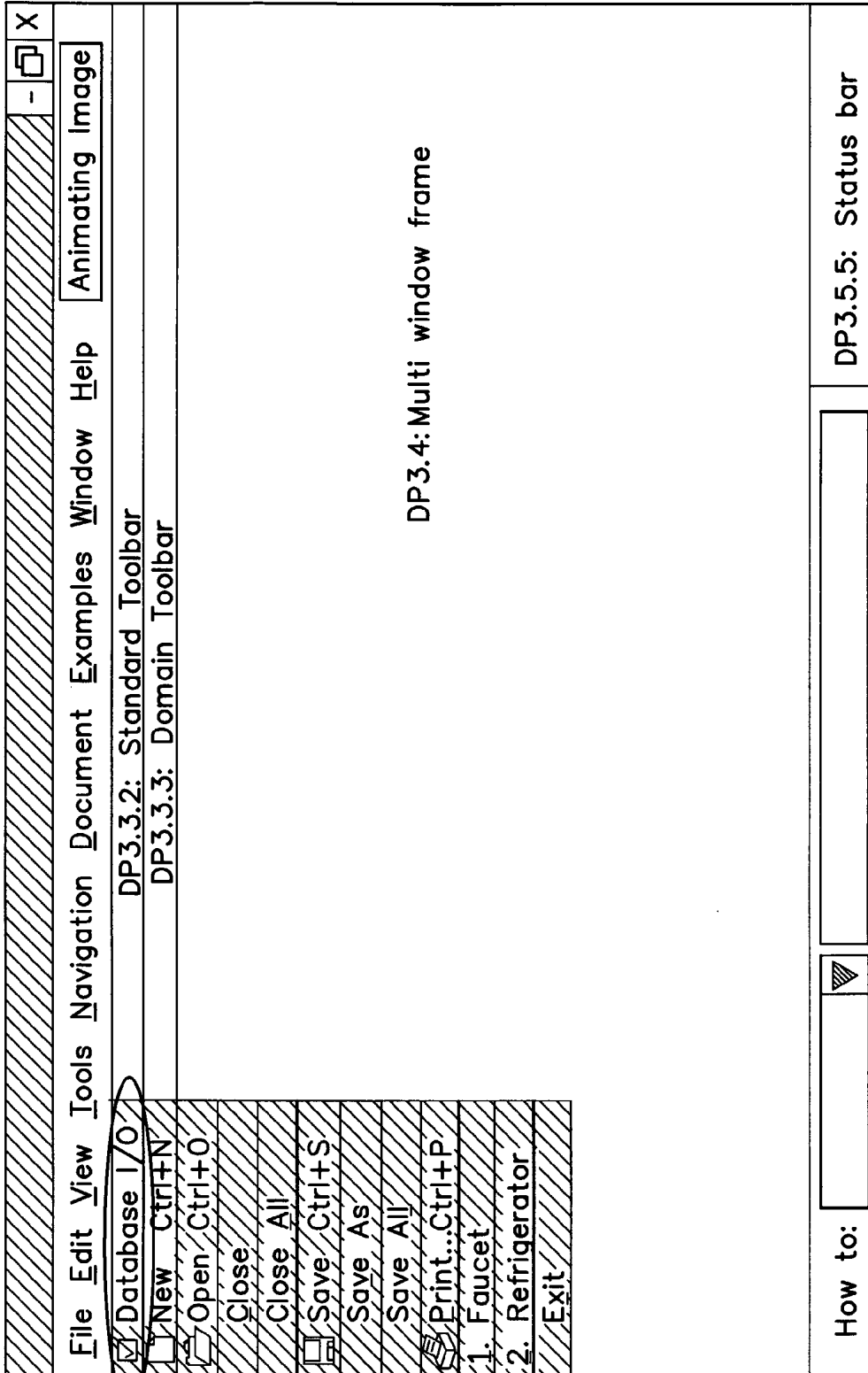

FIG. 57

Mapping		Constraints		Robust Design		Analysis	
Index #	Template	FR	DP	FR	DP	App. Link	Comment
Parent	Control the FR/DP domain	FR/DP window	Mapping tab	<input checked="" type="checkbox"/>	<input type="checkbox"/>		
1	Control the mapping	Mapping tab		<input checked="" type="checkbox"/>	<input checked="" type="checkbox"/>		
2	Assign constraints	Constraints tab		<input type="checkbox"/>	<input checked="" type="checkbox"/>		
3	Refine the design	Robust design tab		<input checked="" type="checkbox"/>	<input type="checkbox"/>		
4	Analyze the design	Analysis tab		<input checked="" type="checkbox"/>	<input checked="" type="checkbox"/>		

	DP#1	DP#2(a)	DP#2(b)	DP#3	DP#4
FR#1	X				
FR#2	X	X			
FR#3	X	X			
FR#4	X		X		X

Measure of Coupling: Information Contents:

DP3.5.6: Scrolling Theorem/Corollary

Design Questions

DP3.5.3:
To do List

DP3.5.4:
Legend Display

DP3.5.7:
Aerial View

FIG. 58

Mapping		Constraints		Robust Design		Analysis	
Index #	Template	Information	DP	Comment	FR	DP	App. Link
Parent		Control the FR/DP domain	FR/DP window		<input checked="" type="checkbox"/>	<input type="checkbox"/>	
1		Control the mapping	Mapping tab Domain tab		<input checked="" type="checkbox"/>	<input checked="" type="checkbox"/>	
2		Assign constraints	Constraints tab		<input type="checkbox"/>	<input type="checkbox"/>	
3		Refine the design	Robust design tab		<input checked="" type="checkbox"/>	<input type="checkbox"/>	
4		Analyze the design	Analysis tab		<input checked="" type="checkbox"/>	<input checked="" type="checkbox"/>	

	DP#.1	DP#.2(a)	DP#.3	DP#.4
FR#.1	X			
FR#.2	X	X		
FR#.3	X		X	
FR#.4	X		X	X

Measure of Coupling: Information Contents:

DP3.5.6: Scrolling Theorem/Corollary

Design Questions

DP3.5.3:
To do List

DP3.5.4:
Legend Display

DP3.5.7:
Aerial View

Radio buttons for current choice
Make diagonal
Make triangular

FIG. 59

Set

Roadmap	Is this step finished?		Menu	Tab	Toolbar
	Yes	No			
Start the design process	Disable	Disable	View-> Project Control	Constraints, Robust design, Analysis	Project Control
	Enable	----->	----->	Constraints	
Activities at one level of the design hierarchy	Enable	Disable			
	Enable			Analysis	
Activities over the design hierarchy	Enable	Disable	View-> Project Control	Robust Design	Project Control
		Disable			

FIG. 60A | FIG. 60B

FIG. 60A

Resources for control			
Buttons			
In Mapping tab	In Constraint tab	In Analysis tab	In Robust Design
One step design matrix control buttons			
Decompose			
Decompose		Flow Chart, Impact List, Check consistency	
		Flow Chart, Impact List, Check consistency	
		Check Constraints, Audit	
		Check Constraints, Audit	

A

B

FIG. 60B

Mapping		Constraints		Robust Design		Analysis		
	Index #	Template	Information	DP	Comment	FR	DP	App. Link
Alt.	Parent		Control the FR/DP domain	FR/DP window		<input checked="" type="checkbox"/>	<input type="checkbox"/>	
	1		Control the mapping	Mapping tab Domain tab		<input checked="" type="checkbox"/>	<input checked="" type="checkbox"/>	
	2		Assign constraints	Constraints tab		<input type="checkbox"/>	<input type="checkbox"/>	
	3		Refine the design	Robust design tab		<input checked="" type="checkbox"/>	<input type="checkbox"/>	
	4		Analyze the design	Analysis tab		<input checked="" type="checkbox"/>	<input checked="" type="checkbox"/>	
Additional blank row								
Cmt	FR#	DP#	DP#	DP#	DP#	DP#	DP#	DP#
/	.1	.1	.2(a)	.2(b)	.3	.3	.4	.4
△	X	X	X	X	X	X	X	X
Set. R/R	X	X	X	X	X	X	X	X
Dec.	X	X	X	X	X	X	X	X
Measure of Coupling: Information Contents:								
DP3.5.6: Scrolling Theorem/Corollary								
Design Questions		DP3.5.3: To do List		DP3.5.4: Legend Display		DP3.5.7: Aerial View		X

FIG. 61

		Analysis	
Mapping		Robust Design	
Constraints		Information	
Index #	Template	FR	DP
Parent	Control the FR/DP domain	FR/DP window	App. Link
1	Control the mapping	Mapping tab	<input checked="" type="checkbox"/>
2	Assign constraints	Domain tab	<input checked="" type="checkbox"/>
3	Refine the design	Constraints tab	<input type="checkbox"/>
4	Analyze the design	Robust design tab	<input type="checkbox"/>
		Analysis tab	<input checked="" type="checkbox"/>

	DP#1	DP#2(a)	DP#2(b)	DP#4	DP#4
FR#1	X				
FR#2	X	X			
FR#3	X	X	X		
FR#4	X		X	X	

Measure of Coupling: Information Contents:

DP3.5.6: Scrolling Theorem/Corollary

Design Questions

DP3.5.3: To do List

DP3.5.4: Legend Display

DP3.5.7: Aerial View

FIG. 62

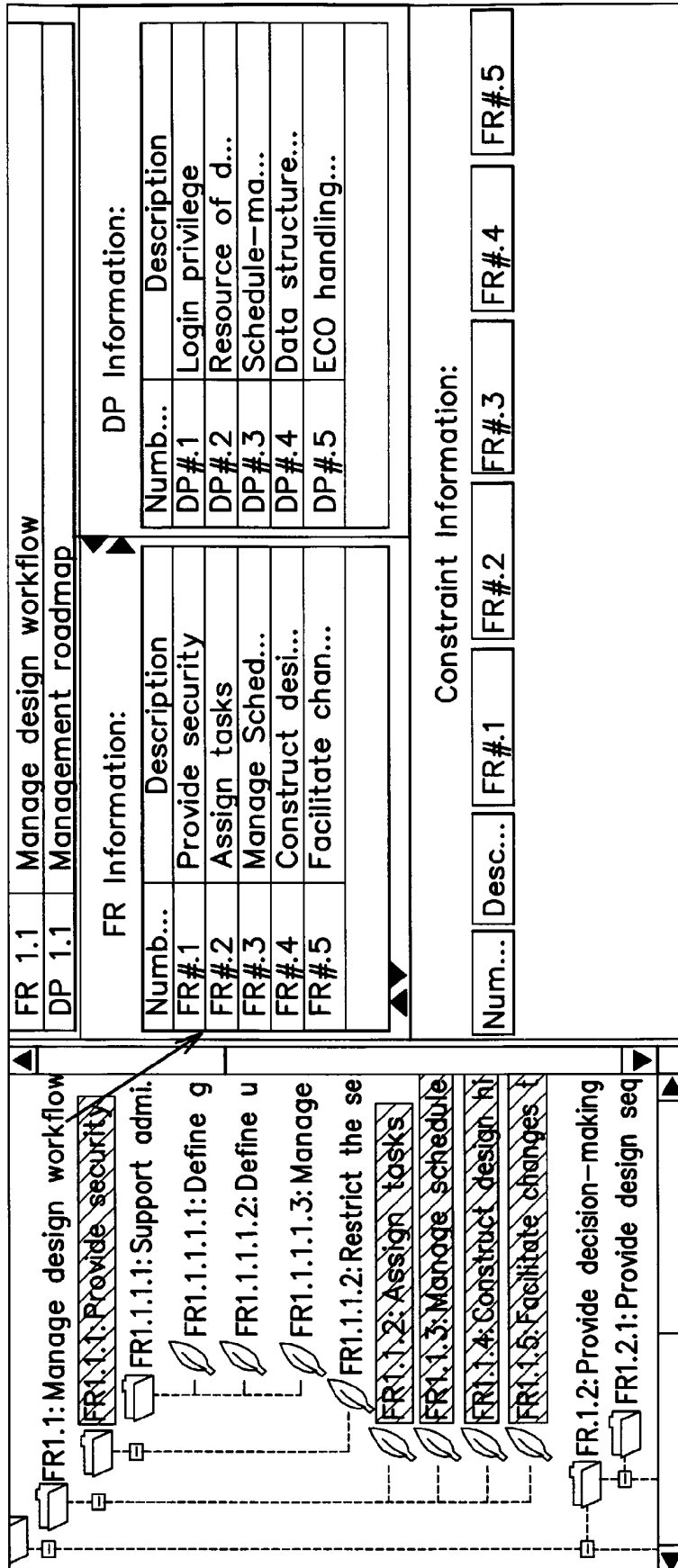

FR 1.1		Manage design workflow	
DP 1.1		Management roadmap	
FR Information:		DP Information:	
Numb...	Description	Numb...	Description
FR#1	Provide security	DP#1	Login privilege
FR#2	Assign tasks	DP#2	Resource of d...
FR#3	Manage Sched...	DP#3	Schedule-ma...
FR#4	Construct desi...	DP#4	Data structure...
FR#5	Facilitate chan...	DP#5	ECO handling...
Constraint Information:		Constraint Information:	
Num...	Desc...	FR#1	FR#2
		FR#3	FR#4
		FR#5	FR#5

FIG. 63A

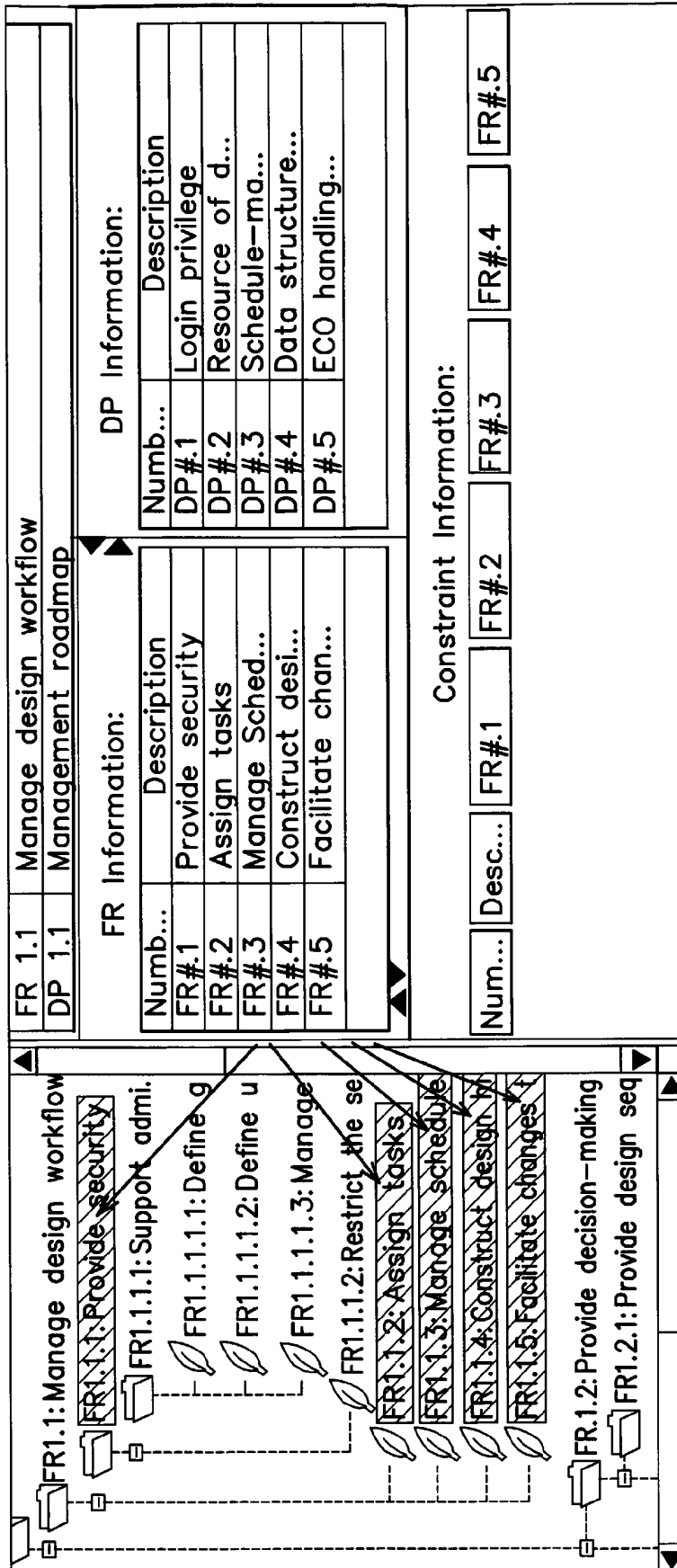

FR 1.1 Manage design workflow	
DP 1.1 Management roadmap	
FR Information:	
Num...	Description
FR# 1	Provide security
FR# 2	Assign tasks
FR# 3	Manage Sched...
FR# 4	Construct desi...
FR# 5	Facilitate chan...
DP Information:	
Num...	Description
DP# 1	Login privilege
DP# 2	Resource of d...
DP# 3	Schedule-ma...
DP# 4	Data structure...
DP# 5	ECO handling...
Constraint Information:	
Num...	Desc...
FR# 1	FR# 1
FR# 2	FR# 2
FR# 3	FR# 3
FR# 4	FR# 4
FR# 5	FR# 5

FIG. 63B

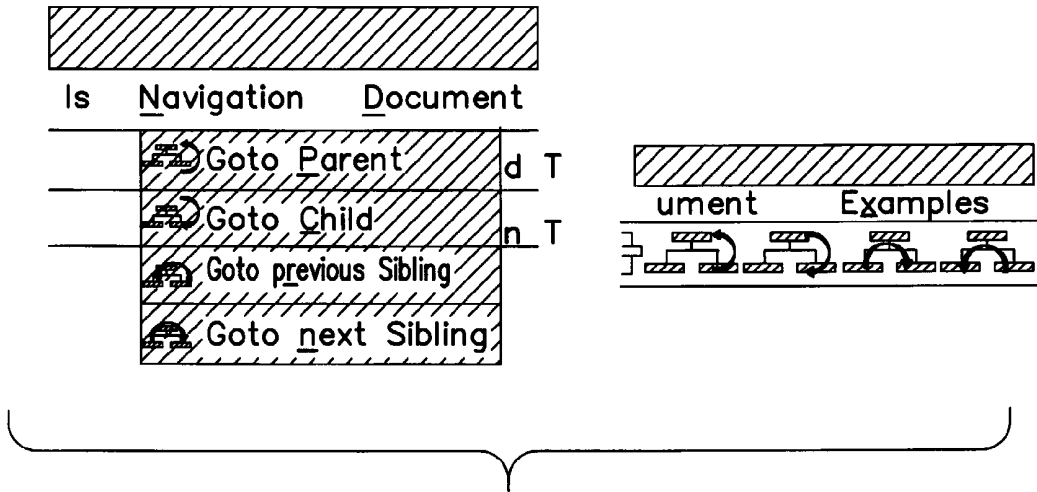

FIG. 64

Control Item	Level 1	Level 2	Level 3	Level 4	Level 5
	Beginner		Intermediate		Expert
FR/DP Mapping	●	●	●	●	●
Design Matrix	●	●	●	●	●
Alternative DP		●	●	●	●
Analysis—Flow Chart		●	●	●	●
Constraints			●	●	●
Comments			●	●	●
CN			●	●	●
CN/FR Mapping			●	●	●
Analysis—Child List			●	●	●
Analysis—Impact List			●	●	●
DP/PV Mapping				●	●
Analysis—Check Consistency				●	●
Analysis—Check Constraints				●	●
Templates				●	●
Verification				●	●
Application Link				●	●
Analysis—Audit					●
Nested(Full) Matrix Handling					●
Robust Design					●
Project Control					●

Available Features

FIG. 65A
 FIG. 65B
 FIG. 65C

FIG. 65A

(B)

(A)

89/127

(C)	Automatic Window Control (Displays the marked item)							(D)			
	FR/DP Window	No Tab									
		Mapping Tab		●						●	
		Constraints Tab			●					●	
		Robust Design Tab								●	
		Analysis Tab	Flow Chart Tab		●						●
			Child List Tab			●					●
			Impact List Tab			●					●
			Check Consistency Tab								●
		Check Constraints Tab								●	
		Audit Tab								●	
	CN Window DP/PV Window Project Control Window Nested (Full) Design Matrix Window									●	
										●	
										●	
								●			

FIG. 65C

Numbering Type		Default Numbering	Alternative Numbering	Example
Numeric		<input checked="" type="checkbox"/>	<input type="checkbox"/>	1, 2, 3
Lower case		<input type="checkbox"/>	<input checked="" type="checkbox"/>	a, b, c
Upper case		<input type="checkbox"/>	<input type="checkbox"/>	A, B, C
Alternative connector		∅		Defined by user
Parent index		#		
Divider				
Example		<p>#=1 [FR 1]</p> <p>[FR #.1] [FR #.2]</p> <p>#=1.2 [FR #.1] [FR #.2]</p>	<p>#=1 [DP 1]</p> <p>[DP #.1] [DP #.1(a)] [DP #.2]</p> <p>#=1.2 [DP #.1] [DP #.2] [DP #.2(a)]</p>	

FIG. 66

Description	Element	Weight factor
No effect	0	0
Small effect	x	1
Large effect	X	2
Unknown	?	1
Number		

A

FIG. 67A FIG. 67B

FIG. 67A

		- X																																																																											
Mapping		Constraints																																																																											
Robust Design		Analysis																																																																											
Design Questions	DP3.5.3: To do List																																																																												
	DP3.5.4: Legend Display																																																																												
	DP3.5.7: Aerial View																																																																												
<table border="1"> <tr> <th>Index #</th> <th>Parent</th> <th>Template</th> <th>FR</th> <th>Information</th> <th>DP</th> <th>FR</th> <th>DP</th> <th>App. Link</th> </tr> <tr> <td>1</td> <td></td> <td></td> <td>Control the FR/DP domain</td> <td>FR/DP window</td> <td></td> <td><input checked="" type="checkbox"/></td> <td><input type="checkbox"/></td> <td></td> </tr> <tr> <td>2</td> <td></td> <td></td> <td>Control the mapping</td> <td>Mapping tab</td> <td></td> <td><input checked="" type="checkbox"/></td> <td><input checked="" type="checkbox"/></td> <td></td> </tr> <tr> <td>3</td> <td></td> <td></td> <td>Assign constraints</td> <td>Constraints tab</td> <td></td> <td><input type="checkbox"/></td> <td><input type="checkbox"/></td> <td></td> </tr> <tr> <td>4</td> <td></td> <td></td> <td>Refine the design</td> <td>Robust design tab</td> <td></td> <td><input checked="" type="checkbox"/></td> <td><input type="checkbox"/></td> <td></td> </tr> <tr> <td></td> <td></td> <td></td> <td>Analyze the design</td> <td>Analysis tab</td> <td></td> <td><input checked="" type="checkbox"/></td> <td><input checked="" type="checkbox"/></td> <td></td> </tr> </table>	Index #	Parent	Template	FR	Information	DP	FR	DP	App. Link	1			Control the FR/DP domain	FR/DP window		<input checked="" type="checkbox"/>	<input type="checkbox"/>		2			Control the mapping	Mapping tab		<input checked="" type="checkbox"/>	<input checked="" type="checkbox"/>		3			Assign constraints	Constraints tab		<input type="checkbox"/>	<input type="checkbox"/>		4			Refine the design	Robust design tab		<input checked="" type="checkbox"/>	<input type="checkbox"/>					Analyze the design	Analysis tab		<input checked="" type="checkbox"/>	<input checked="" type="checkbox"/>		<table border="1"> <tr> <th>FR#</th> <th>DP#</th> <th>DP#</th> <th>DP#</th> </tr> <tr> <td>FR#1</td> <td>X</td> <td>DP#1</td> <td>DP#4</td> </tr> <tr> <td>FR#2</td> <td>X</td> <td></td> <td></td> </tr> <tr> <td>FR#3</td> <td>X</td> <td>X</td> <td></td> </tr> <tr> <td>FR#4</td> <td>X</td> <td>X</td> <td>X</td> </tr> </table>			FR#	DP#	DP#	DP#	FR#1	X	DP#1	DP#4	FR#2	X			FR#3	X	X		FR#4	X	X	X
Index #	Parent	Template	FR	Information	DP	FR	DP	App. Link																																																																					
1			Control the FR/DP domain	FR/DP window		<input checked="" type="checkbox"/>	<input type="checkbox"/>																																																																						
2			Control the mapping	Mapping tab		<input checked="" type="checkbox"/>	<input checked="" type="checkbox"/>																																																																						
3			Assign constraints	Constraints tab		<input type="checkbox"/>	<input type="checkbox"/>																																																																						
4			Refine the design	Robust design tab		<input checked="" type="checkbox"/>	<input type="checkbox"/>																																																																						
			Analyze the design	Analysis tab		<input checked="" type="checkbox"/>	<input checked="" type="checkbox"/>																																																																						
FR#	DP#	DP#	DP#																																																																										
FR#1	X	DP#1	DP#4																																																																										
FR#2	X																																																																												
FR#3	X	X																																																																											
FR#4	X	X	X																																																																										
<table border="1"> <tr> <td>X</td> <td>X</td> <td>0</td> <td>?</td> </tr> </table>	X	X	0	?	Measure of Coupling: Information Contents:																																																																								
X	X	0	?																																																																										
Alt.	DP3.5.6: Scrolling Theorem/Corollary																																																																												
Cmt																																																																													
Set.																																																																													
R/R																																																																													
Dec.																																																																													

FIG. 67B

93/127







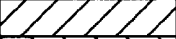

		Legend category		
		Color	Font	Line
Display	Activated cell			N/A
	Normal			
	Default			N/A
	Focus			N/A
	Alternative			N/A
	Redundant			N/A
	Constraints			N/A
	Comments			N/A
Design Matrix	Uncoupled		N/A	
	Decoupled		N/A	
	Coupled		N/A	
	Undefined		N/A	
Template	Process			—
	Transport			---
	...			

FIG. 68

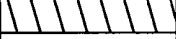
94/127



FIG. 69

X
-

Mapping

Constraints

Robust Design

Comment

Analysis

Index

Information

Information

Comment

Analysis

*What are the functions that the system/product should perform?
 *How do you achieve these functions?
 *Do you think this set of FRs is minimum set to fulfill the parent level requirements?
 *Does changing this DP affect the FR?
 *Does the choice of this DP affect that FR?
 *Can the DP be designed without affecting the FR?
 *...

Cmt						
/	X	X	X	X	X	X
△	X	X	X	X	X	X

Measure of Coupling: / Information Contents: /

DP3.5.6: Scrolling Theorem/Corollary

Design Questions

DP3.5.3:
To do List

DP3.5.4:
Legend Display

DP3.5.7:
Aerial View

FIG. 70

Mapping		Constraints		Robust Design		Analysis	
Index #	Template	Information		Comment			
Parent		FR	DP	FR	DP	App. Link	
Alt. 1		Control the FR/DP domain	FR/DP window	<input checked="" type="checkbox"/>	<input type="checkbox"/>		
		Control the mapping	Mapping tab	<input checked="" type="checkbox"/>	<input checked="" type="checkbox"/>		
			Domain tab	<input type="checkbox"/>	<input checked="" type="checkbox"/>		

*Due to the changes on DP xx, you have to check the impacts.
 *You didn't fill out the Design Matrix information at FR 1.2.x node.
 *You didn't fill out the constraint information on this node.
 *You didn't set up the relation for FR and CA.
 *...

FR#.3	X		X				
FR#.4	X		X				X

Design Questions: DP3.5.3: To do List
 DP3.5.4: Legend Display
 DP3.5.7: Aerial View

Measure of Coupling: Information Contents:

DP3.5.6: Scrolling Theorem/Corollary

FIG. 71

X
Rank/Rearrange the Design Matrix combination...

Matrix Information:

A0(1.1)	DP: #.1	DP: #.2(1)
FR: #.1	X	O
FR: #.2	O	X

Change

Cancel

DP Ranking Assumptions

Start FR/DP association

Free association of DPs

Get Rank Combination

Ranking Information:

FR: #.1	FR: #.2	Status	Off X's	Coupled X's
DP: #.1	DP: #.2(1)	Uncoupled	0/4	n/a
DP: #.1	DP: #.2	Uncoupled	0/4	n/a
DP: #.1(1)	DP: #.2(1)	Decoupled	1/4	n/a
DP: #.1(1)	DP: #.2	Decoupled	1/4	n/a
DP: #.1	DP: #.2(2)	Decoupled	1/4	n/a
DP: #.1(1)	DP: #.2(2)	Coupled	2/4	1

Display Options

Number

Description

Keyword

Rearrange Sequence:

Rearranged FR Order

No Rearrange

FR: 1-FR: 2-

FR: 2-FR: 1-

Colors

Unknown design

Uncoupled Design

Decoupled Design

Coupled Design

Alternative DP

Redundant DP

Has Comment

Help

Design Matrix Table:

A0(1.1)	DP#1	DP#1(1)	DP#2	DP#2(1)	DP#2(2)
FR#1	X		O		X
FR#2	O	X	X		X

FIG. 72

Child List		Impact List		Inconsistency		Decoupling	
Number	FR Description	FR Description	DP Description				
1.1	Manage design workflow		Management roadmap				
1.1.1	Provide security		Login privilege				
1.1.2	Assign tasks		Resource of design activity				
1.1.3	Manage schedule		Schedule--managing tool (e.g. MS Project)				
1.1.4	Construct design hierarchy		Data structure for Axiomatic Design concept				
1.1.5	Facilitate changes to the design		ECO handling tool				
1.1.1.1	Support administrative tool		User manager				
1.1.1.2	Restrict the security access level		Authority code				
1.1.1.1.1	Define group		Group specification				
1.1.1.1.2	Define user		User specification				
1.1.1.1.3	Manage authority code		Authority code specification				

FIG. 73

Design Matrix Table:

A1(1.1)	DP#1	DP#2	DP#3	DP#4	DP#5
FR#1	X	0	0	0	0
FR#2	X	X	0	0	0
FR#3	X	X	X	X	X
FR#4	X	X	0	X	0
FR#5	0	0	0	X	X

Child List

Impact List

Inconsistency

Decoupling

Number	FR Description	DP Description
1.4.1	Support data file	File handling
1.4.2	Support database	Database handling
1.4.2.1	Provide consistency during data read a...	Data file format
1.4.2.2	Control error during read/write	Exception handling
1.4.2.3	Convert data from old version	Data file converter
1.4.2.4	Read data	Method for read
1.4.2.5	Write data	Method for write
1.4.2.6	Provide utility to deal with the program...	Method for utility
1.5	Provide utility function	Plug-in software
1.5.1	Handle external applications	Standard interface for external appli...
1.5.2	Teach the axiomatic design concept	Education software
1.5.3	Simulate the system architecture	Simulation software
1.5.4	Draw the Design Parameter figure	CAD Software
1.5.5	Analyze the system performance	Analysis software(i.e. ANSYS, NAS...
1.3	Support user friendliness of the software	Graphical User Interface software

Display Options
 Number
 Description
 Keyword

Colors
 Uncoupled Design
 Decoupled Design
 Coupled Design
 No Effect
 Has Effect
 Has Comment

FIG. 74

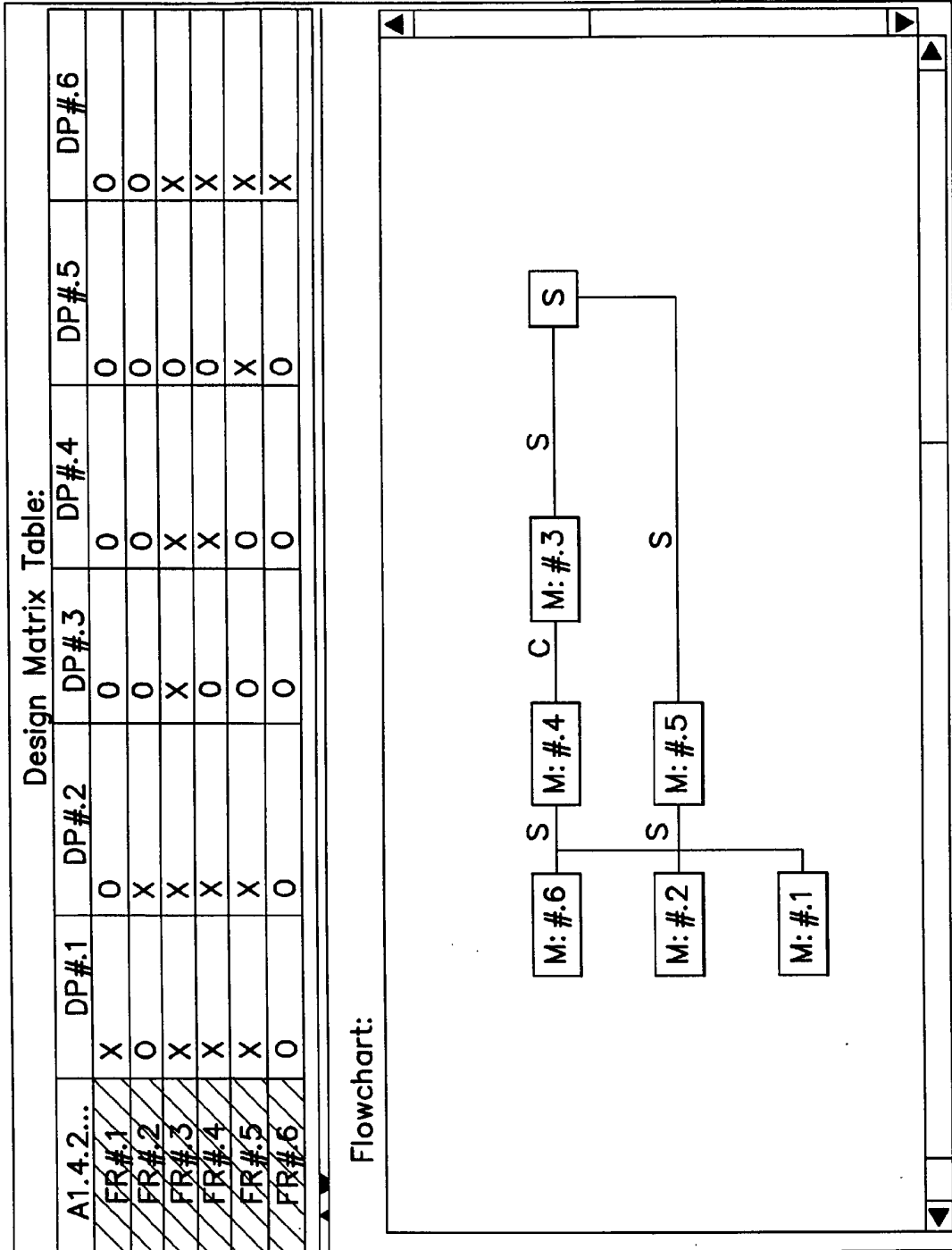

FIG. 75

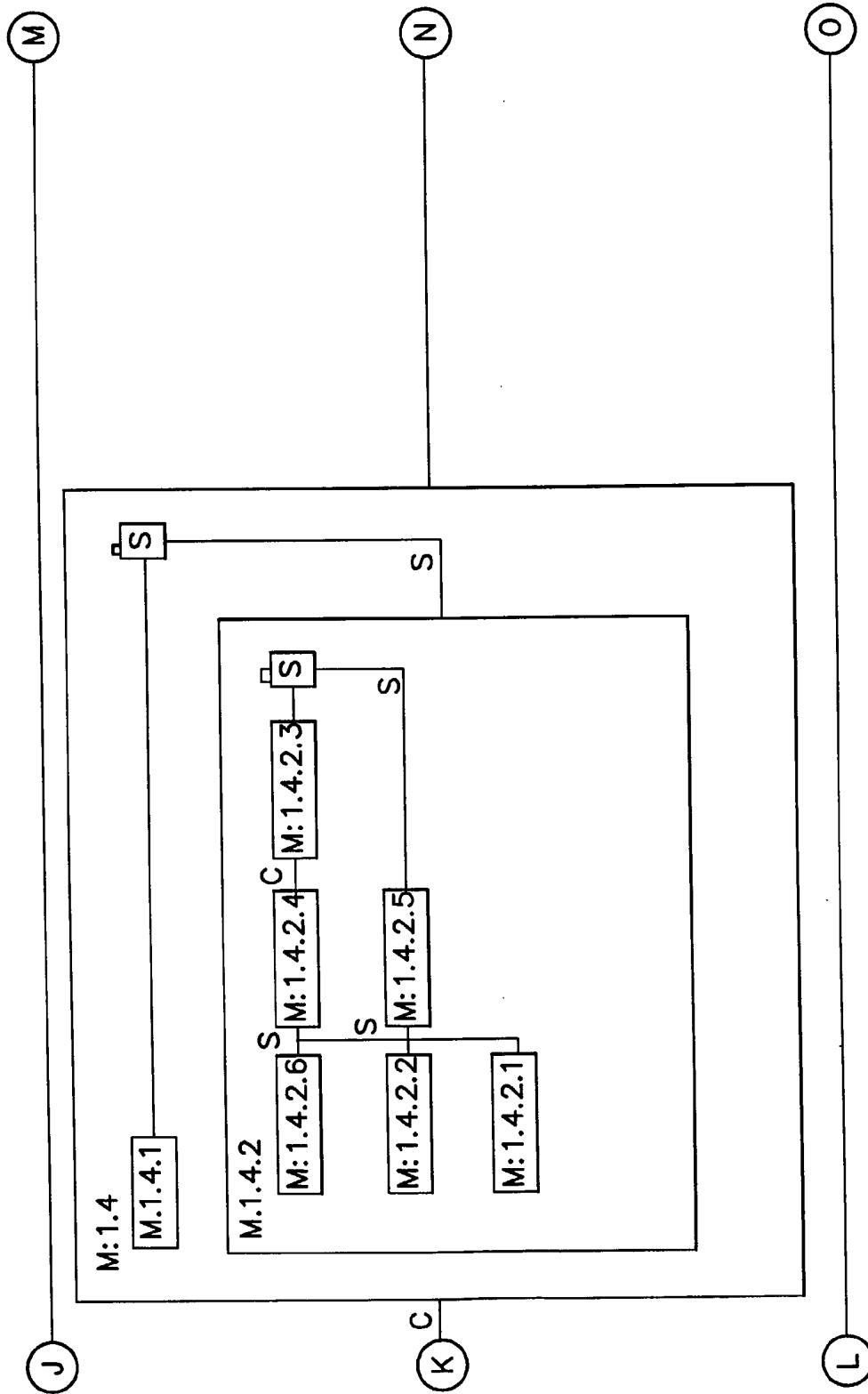

FIG. 76C

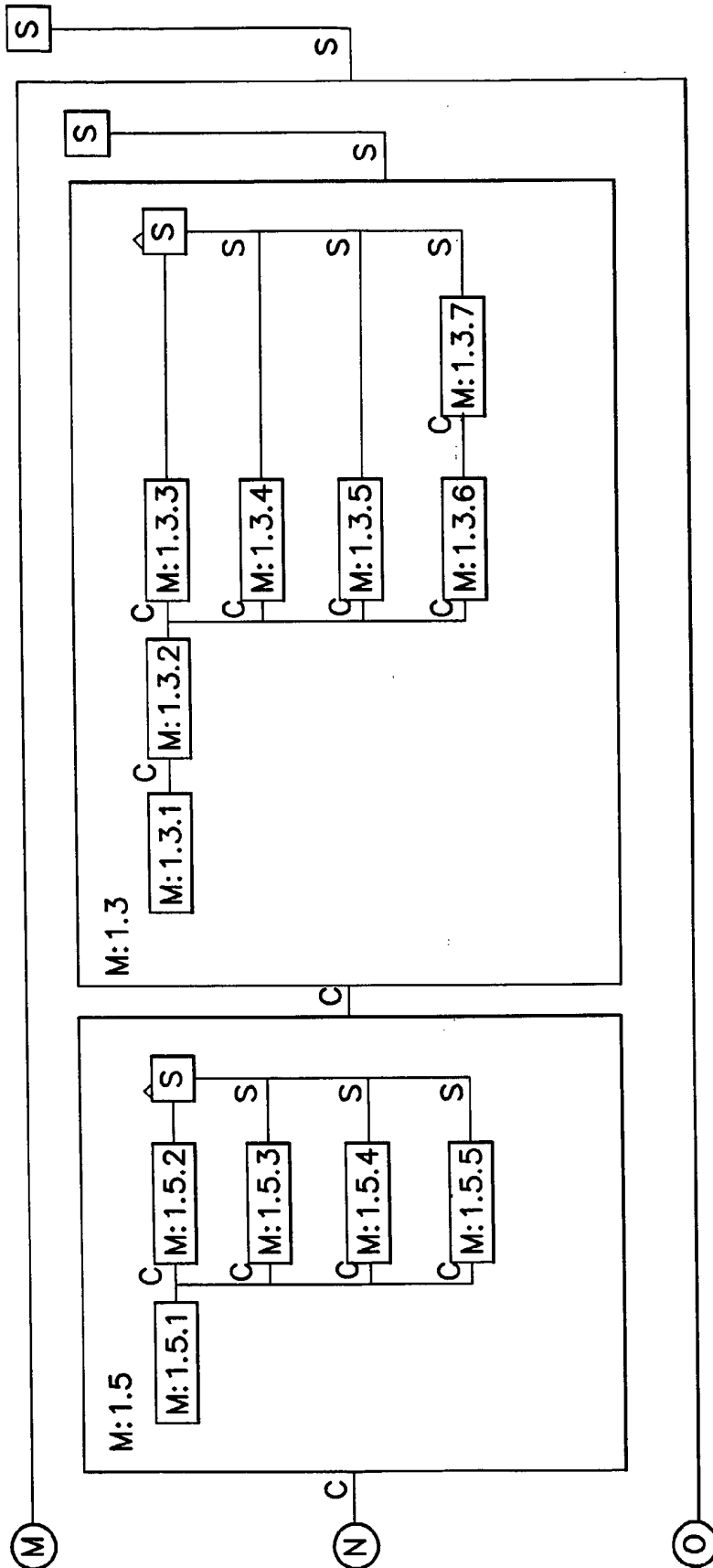

FIG. 76D

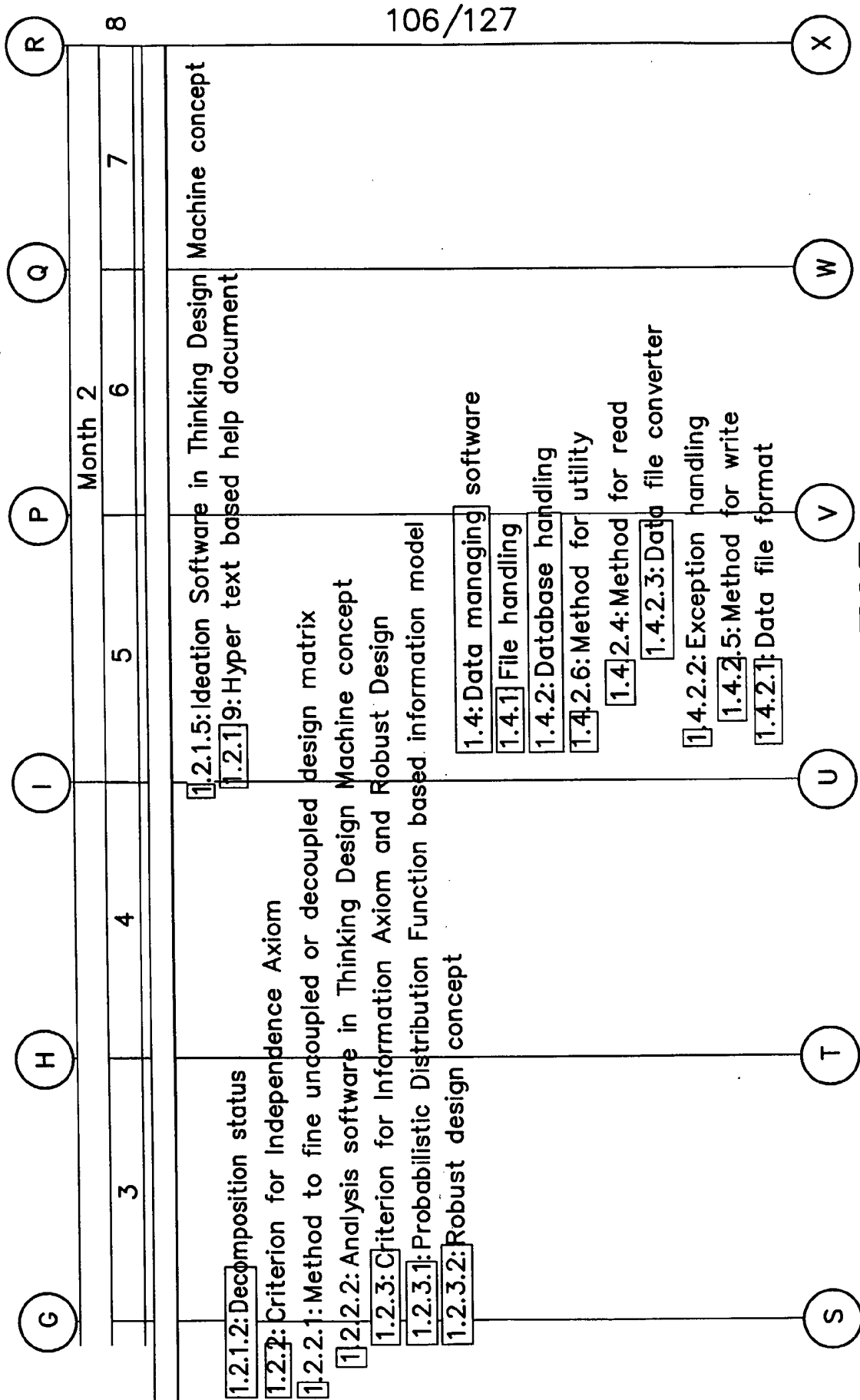

FIG. 76F

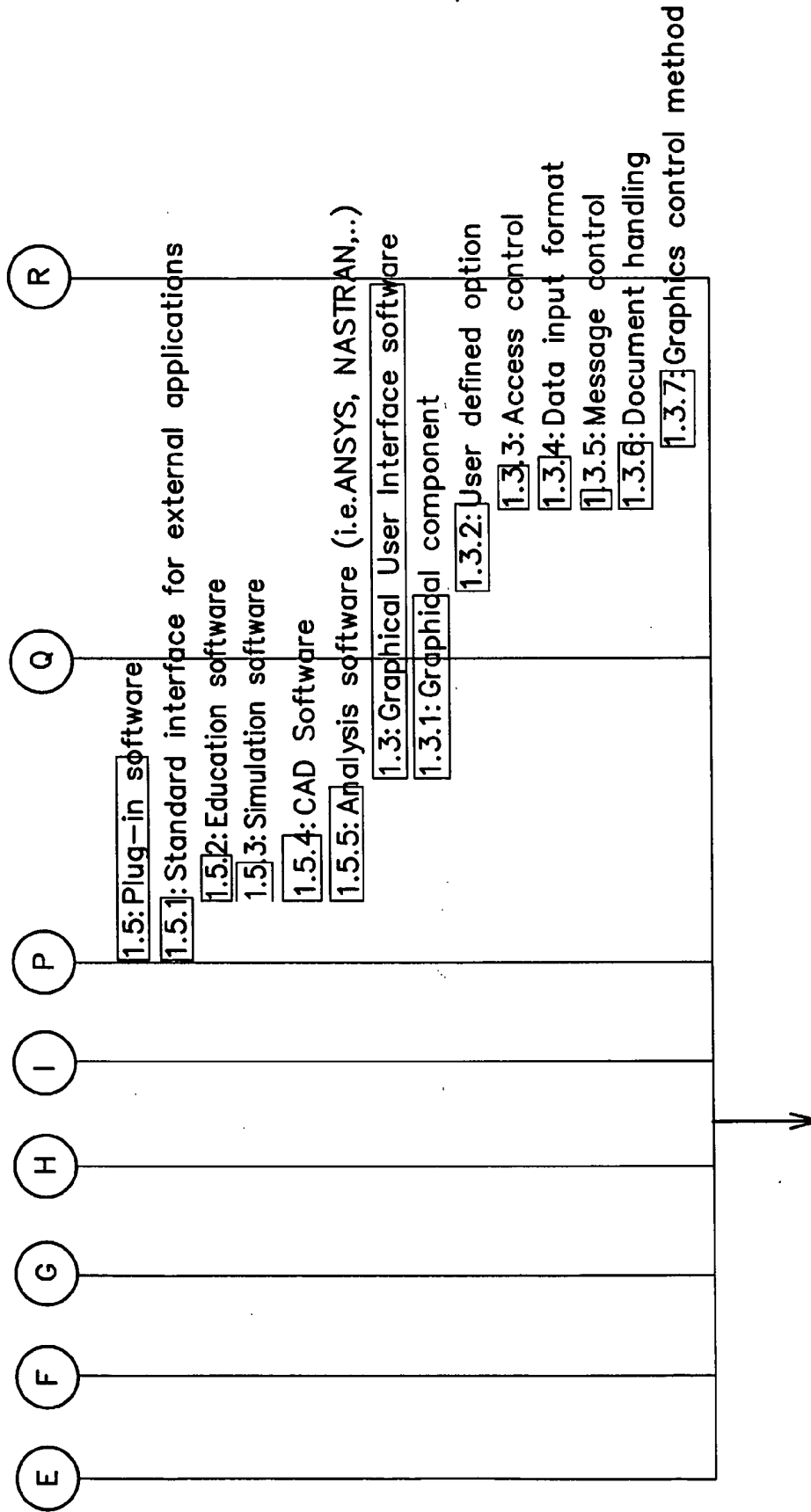

FIG. 76G

108/127

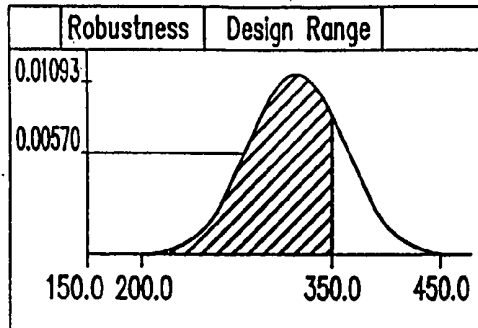

FIG. 77A

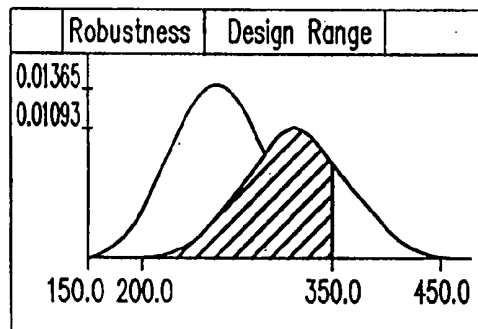

FIG. 77B

109/127

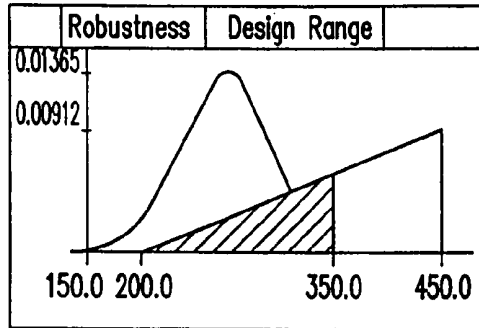

FIG. 77C

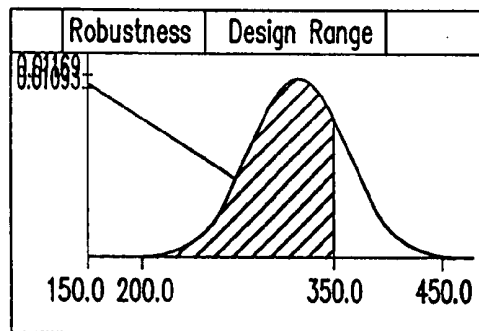

FIG. 77D

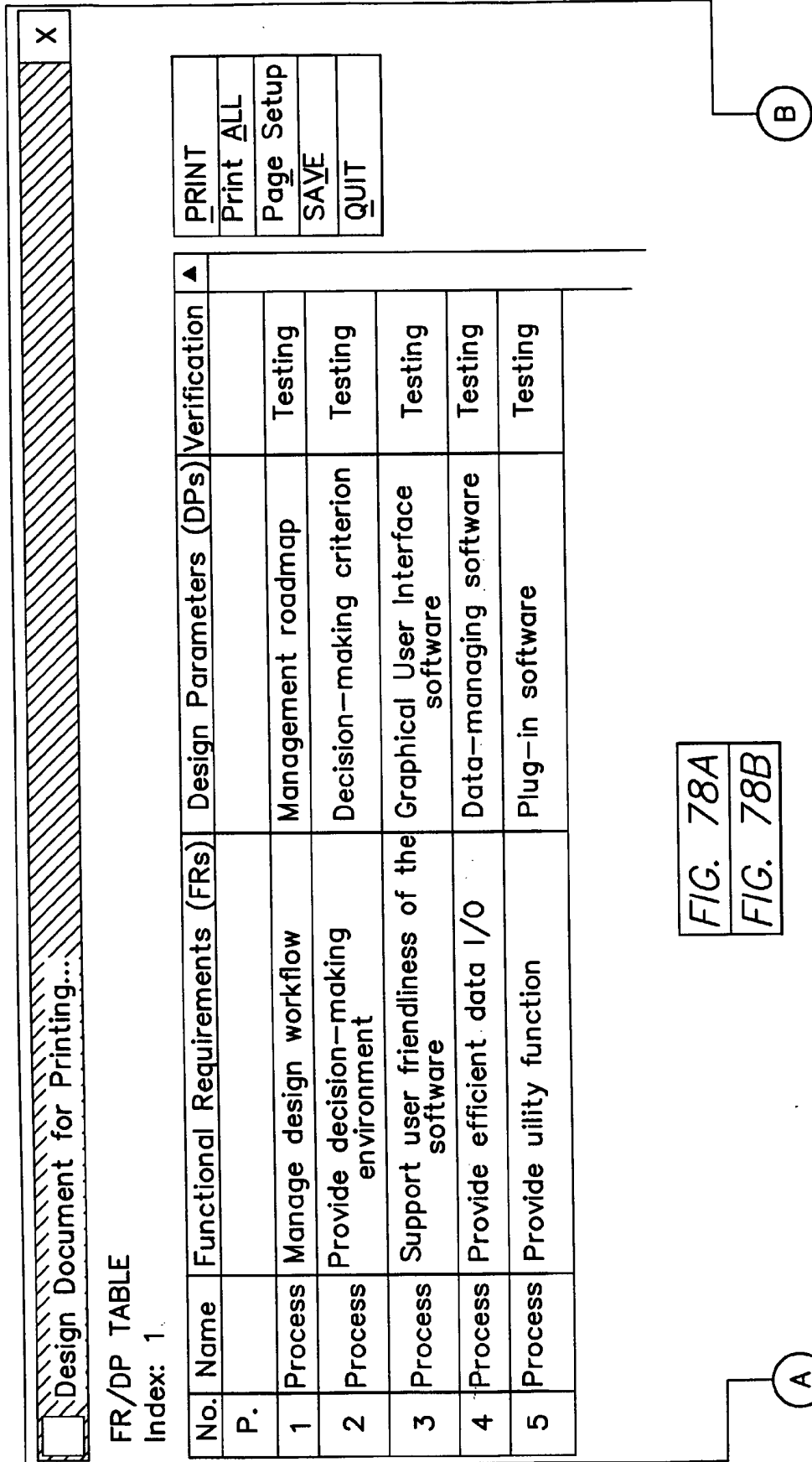

FIG. 78A
FIG. 78B

FIG. 78A

(A)

Total Design Matrix Information

	DP.#.1	DP.#.2	DP.#.3	DP.#.4	DP.#.5
FR.#.1	X	0	0	0	0
FR.#.2	X	X	0	0	0
FR.#.3	X	X	X	X	X
FR.#.4	X	X	0	X	0
FR.#.5	0	0	0	X	X

(B)

Related Constraints

No.	Parent	Keyword	Description	Comment	1	2	3	4	5	Verification
1	Designer	Impact	Make Impacts		*	*	*	*	*	Testing
2	Marketing	Speed	Support running as fast as possible		*	*	*	*	*	Testing
3	Designer	Bug	Eliminate bugs		*	*	*	*	*	Testing
4	Marketing	External Application	Facilitate use with external applications		*	*	*	*	*	Testing
5	Marketing	Multi-platform	Functions across platforms				*	*	*	Testing

Page Information
Page: 1

Document Format

Customer Needs

FR.DP.PV Table

FR.DP.PV Comment

Constraints

Design Matrix

Design Matrix Comment

Default Display

Full Display

SET

FIG. 78B

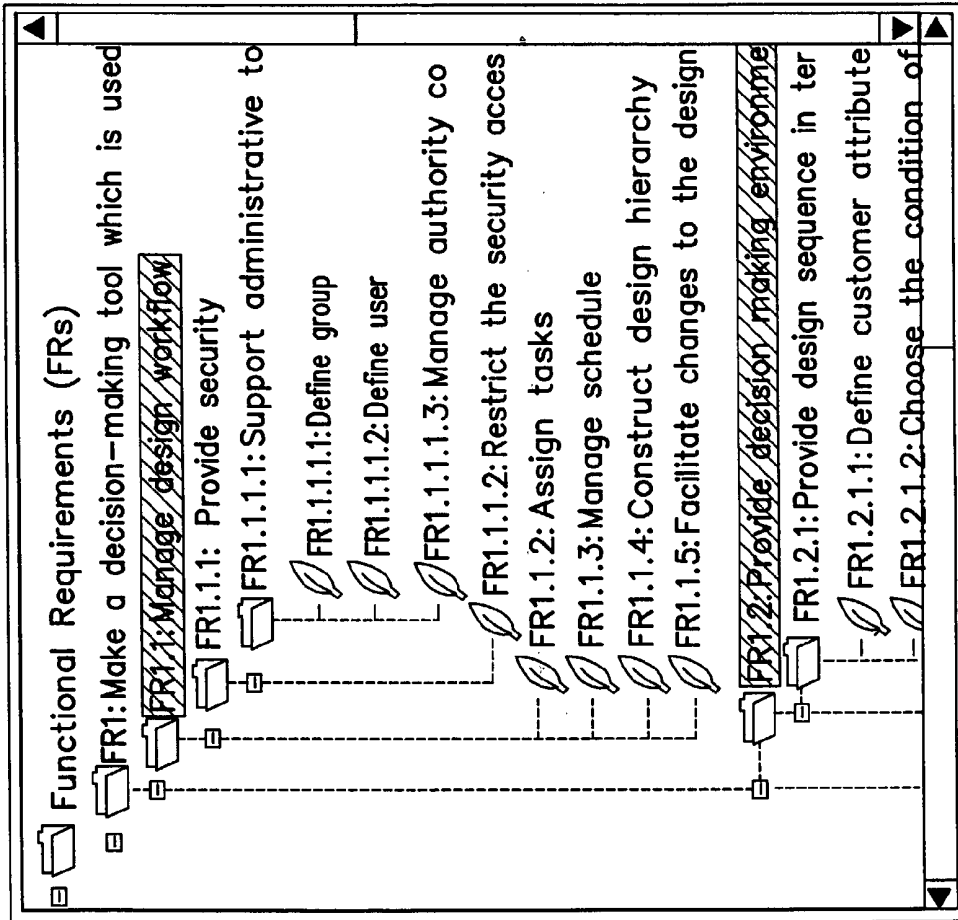

FIG. 79A

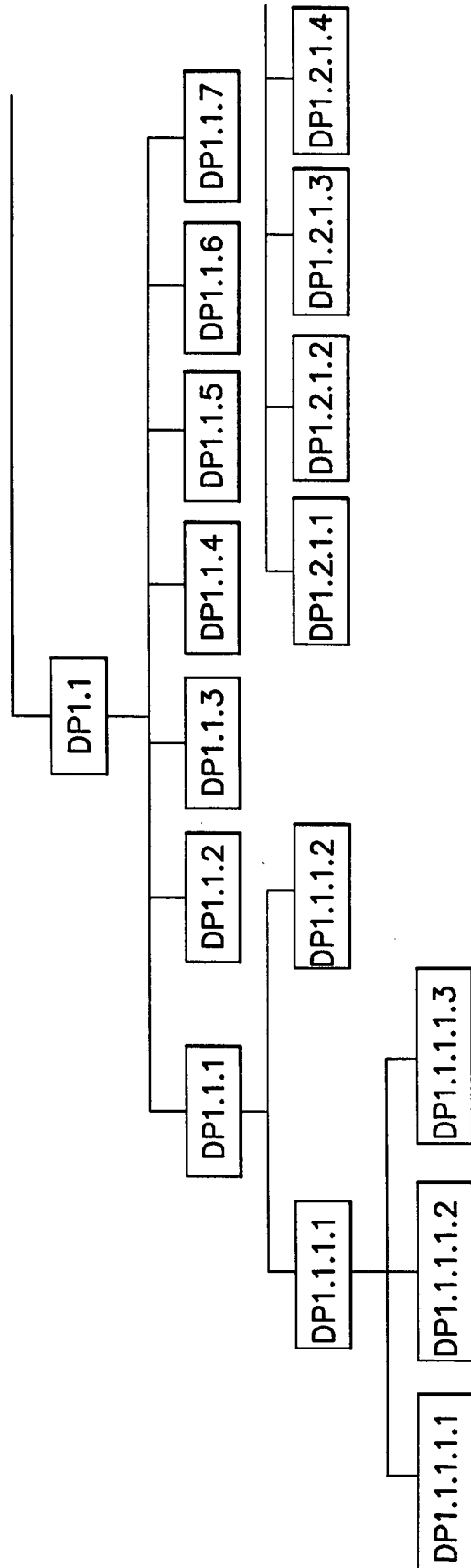

FIG. 79B

Mapping DP#1 X FR#1 X FR#2 X FR#3 X FR#4 X		Constraints DP#2(a) DP#2(b) DP#3 DP#4		Robust Design DP#3 DP#4	Analysis DP#4	Design Questions
		DP#2(a) DP#2(b) DP#3 DP#4				
Flow Chart Child List Impact List Check Consistency Check Constraints Audit		DP3.5.3: To do List DP3.5.4: Legend Display DP3.5.7: Aerial View				
Check my design: -Is the design completely uncoupled/decoupled? -Does it satisfy Constraints? -Does each leaf DP have a drawing? -Are there any unchecked CN's? -Has everybody done consistency check? -Does the default design have the least information? -Are all the leaf nodes checked as leaf? -...						
DP3.5.6: Scrolling Theorem/Corollary						

FIG. 80

115/127

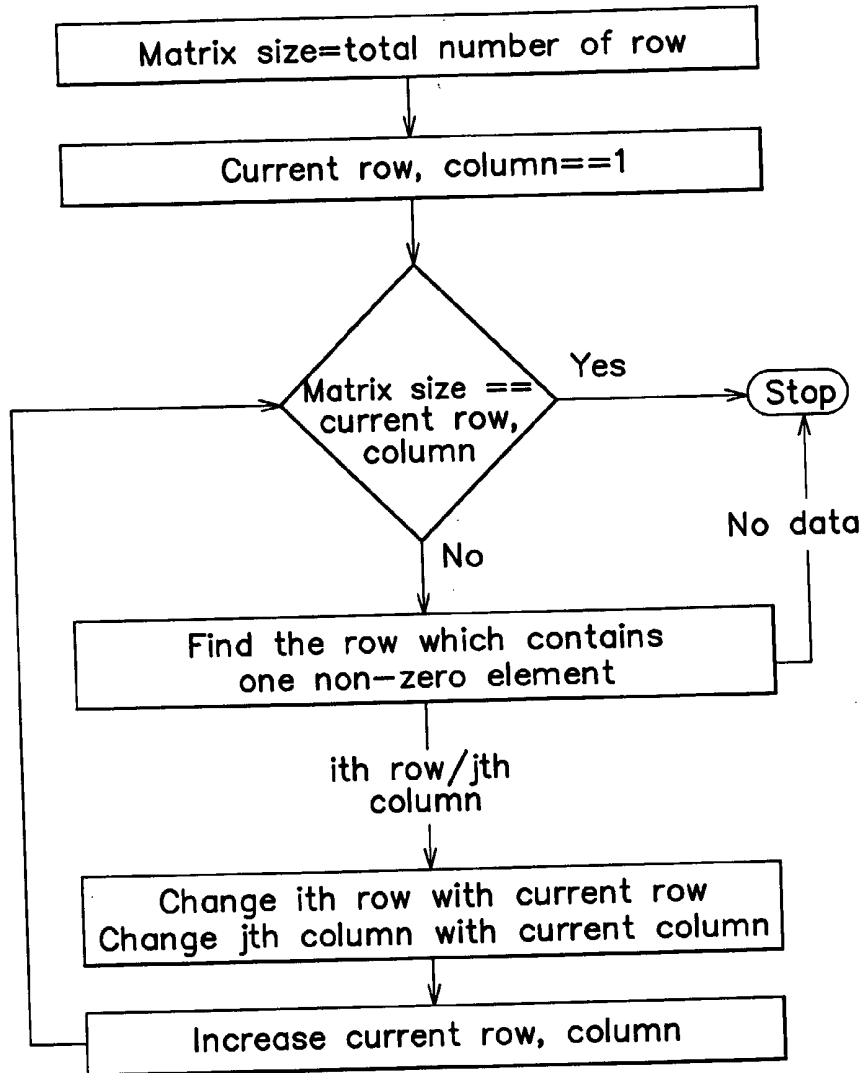

FIG. 81

116/127

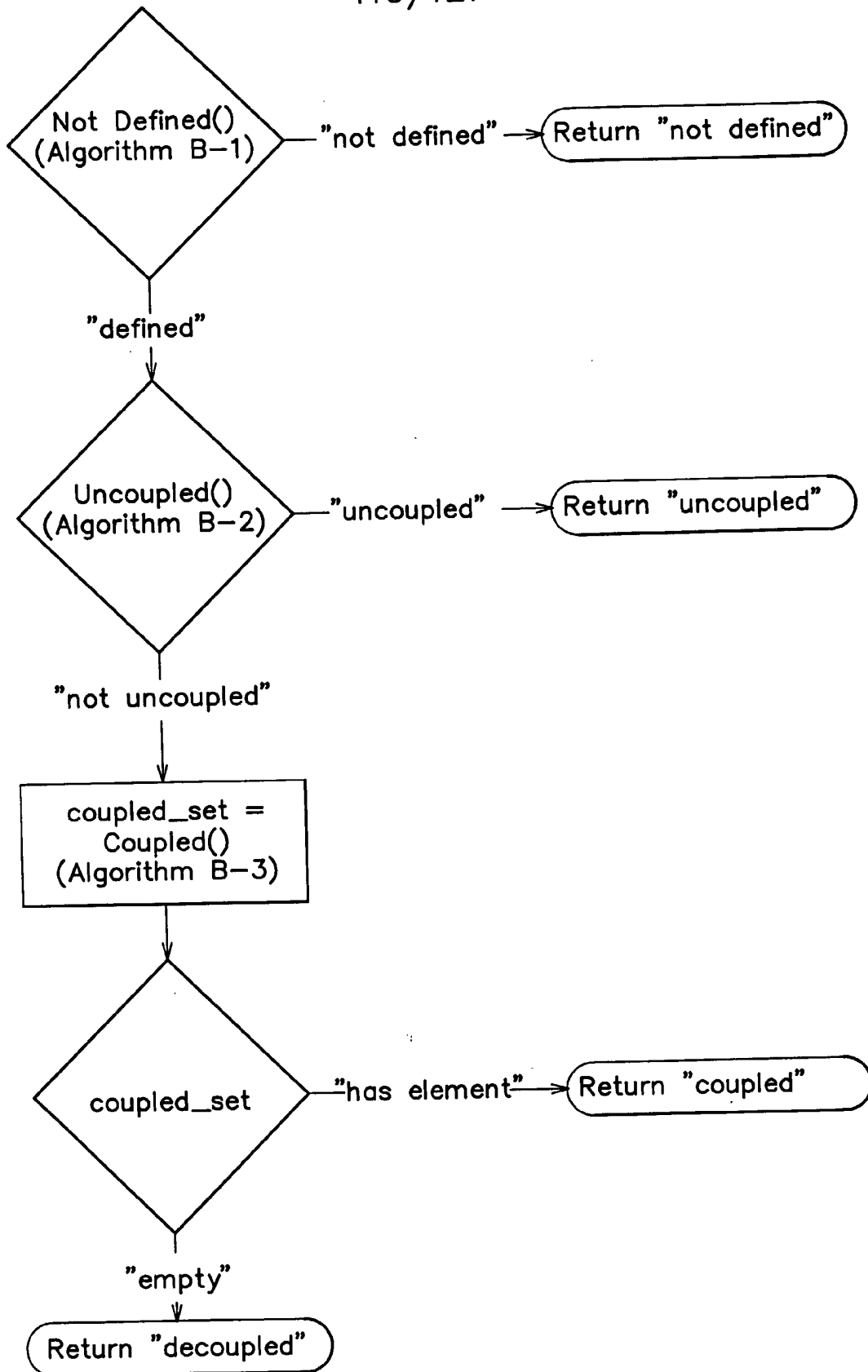

FIG. 82

117/127

```

Loop One (int row=0; row<total_row_number; row++) {
  Loop Two (int column=0; column <total_column_number; column++) {
    If(matrix[row][column] == "empty")
      return "not defined"

    If(row == column) {
      If(matrix[row][column] == "0")
        return "not defined"
    }
  }
}
return "defined"

```

If one of the diagonal element has "0", the design is not defined in terms of the axiomatic design viewpoint

FIG. 83

```

Loop One (int row=0; row<total_row_number; row++) {
  Loop Two (int column=0; column <total_column_number; column++) {
    If(row != column) {
      If(matrix[row][column] == "X")
        return "not uncoupled"
    }
  }
}
return "uncoupled"

```

FIG. 84

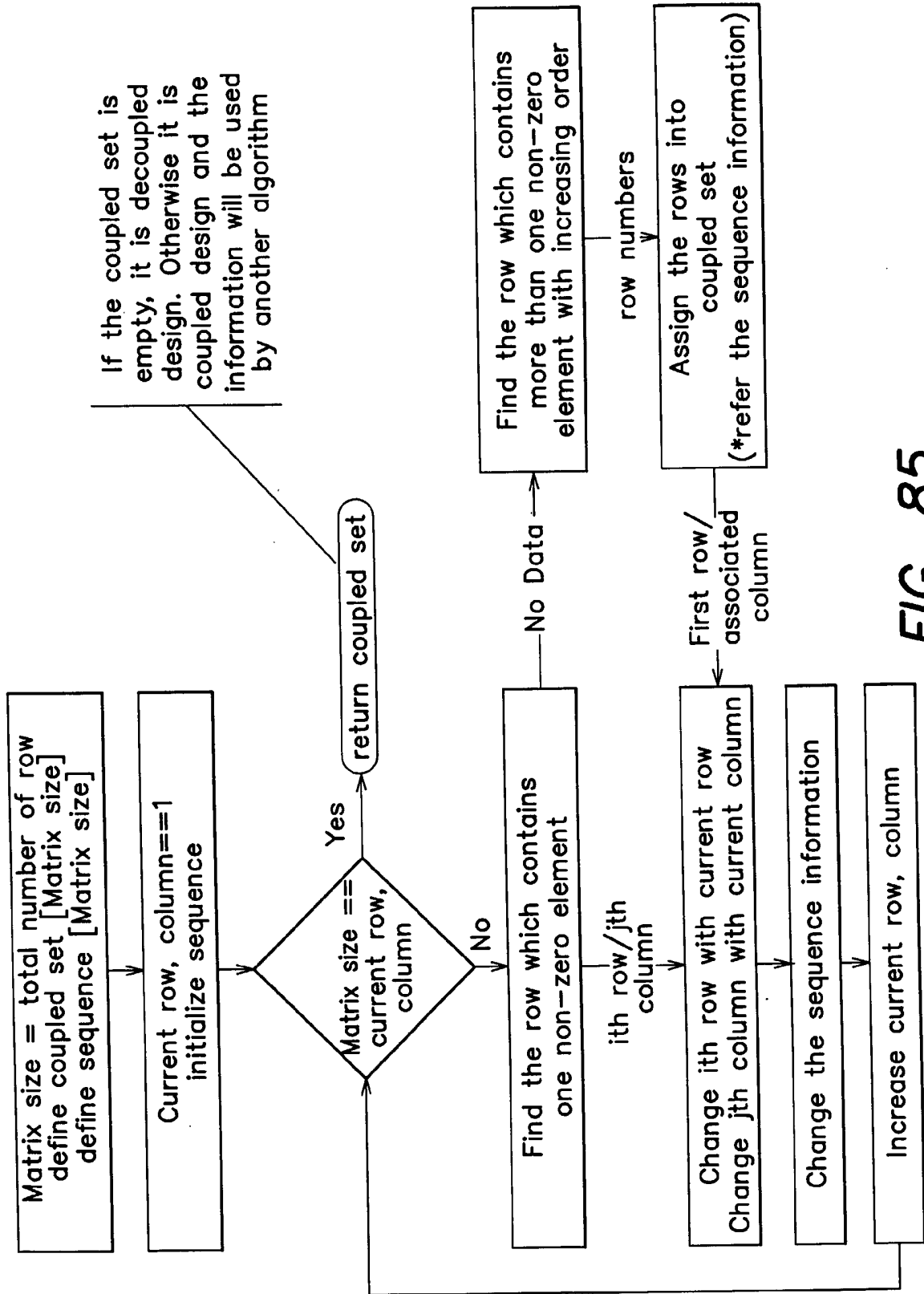

FIG. 85

119/127

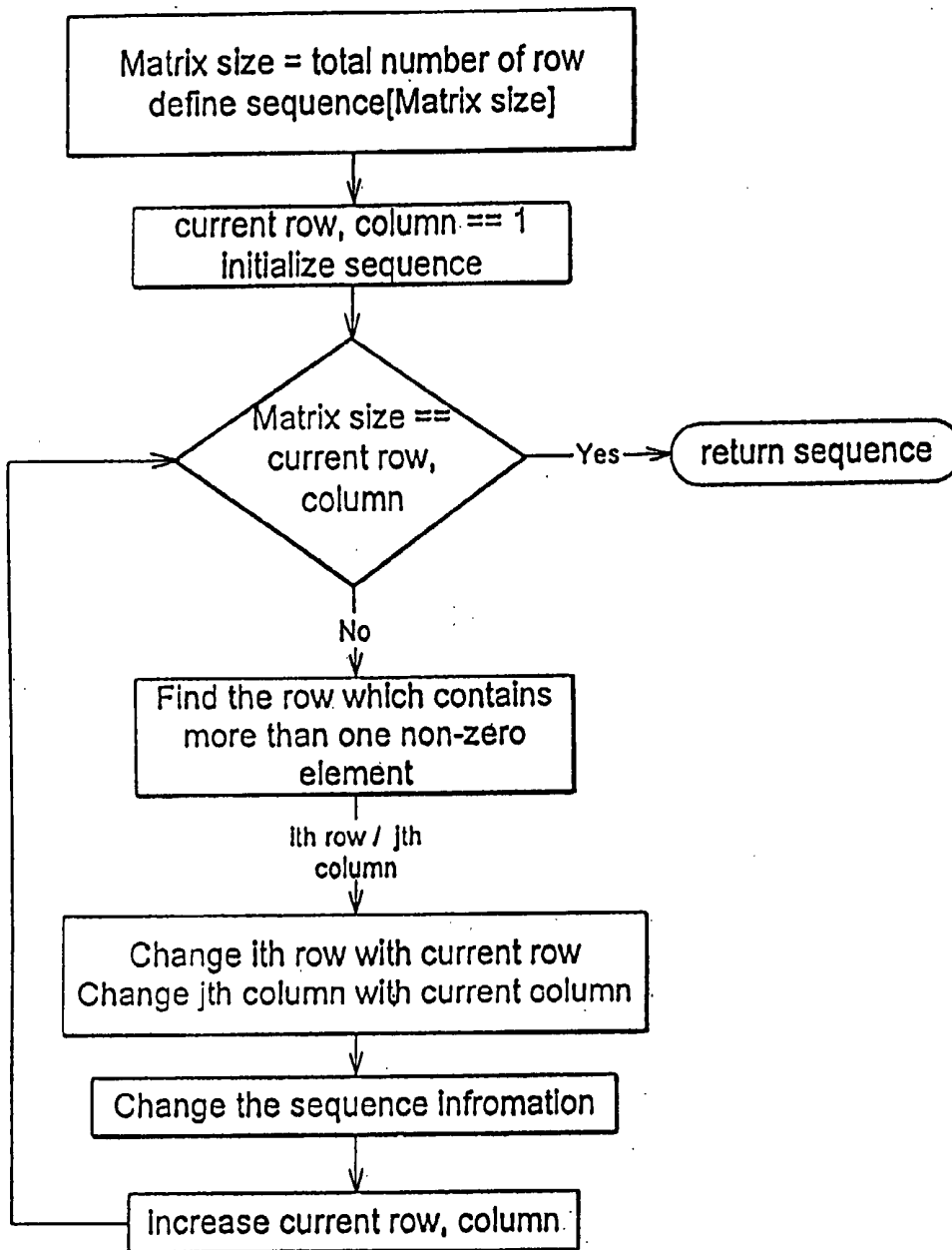

FIG. 86

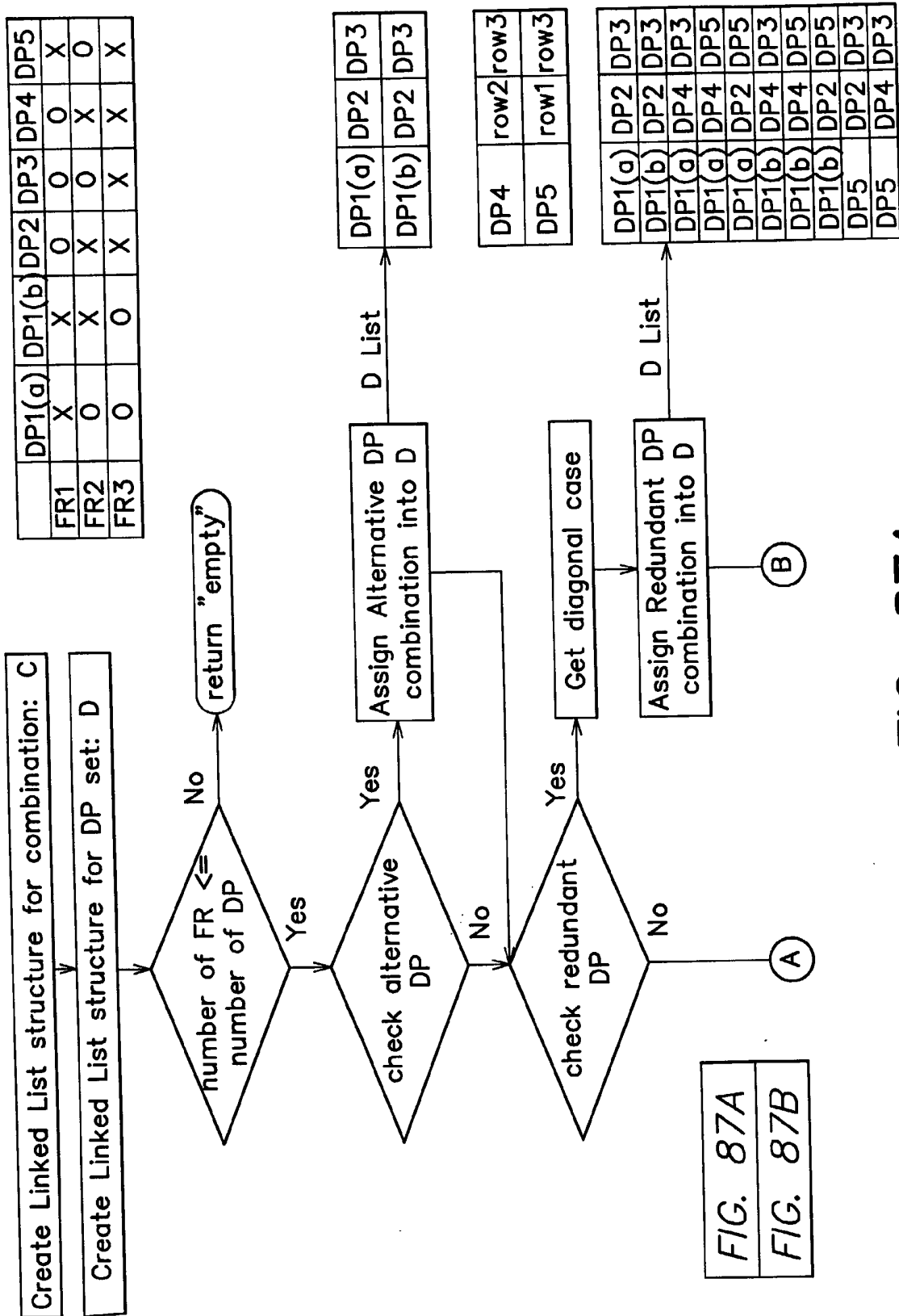

FIG. 87A

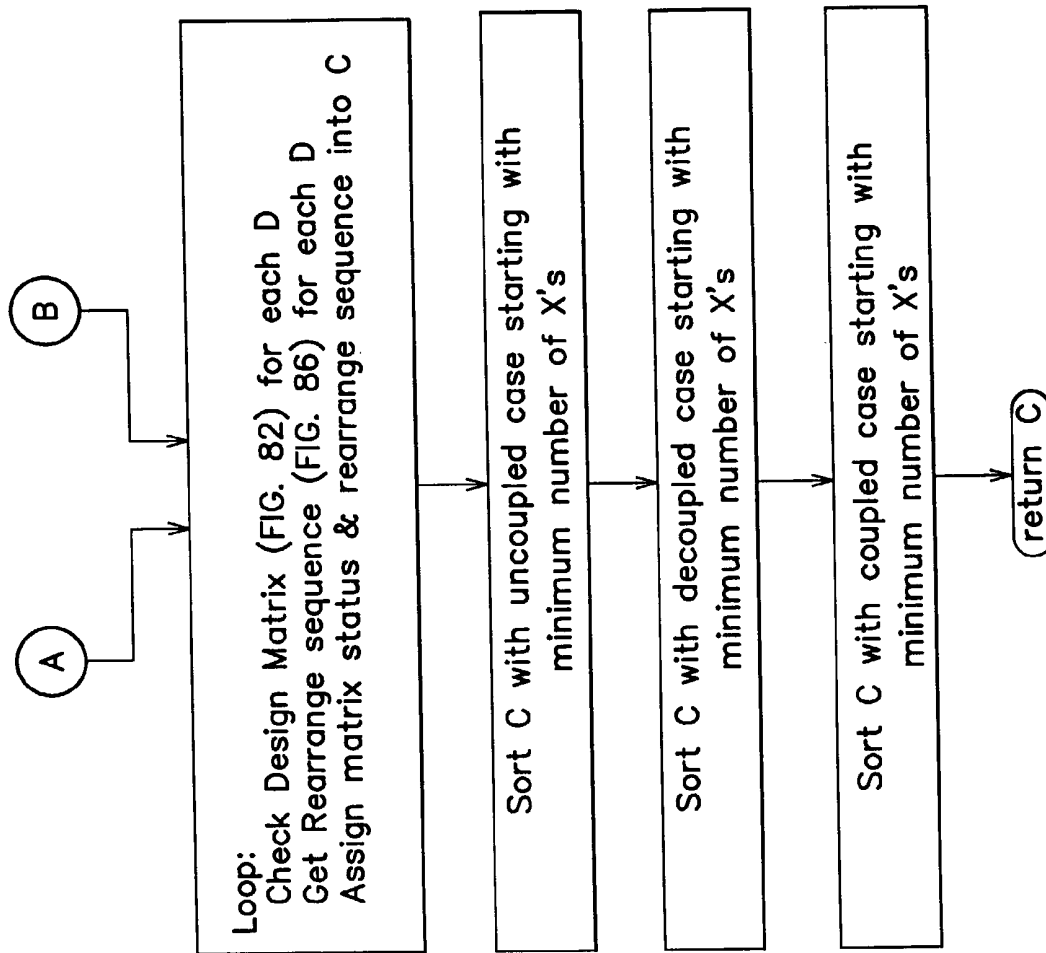

FIG. 87B

	DP1(a)	DP1(b)	DP2	DP3	DP4	DP5
FR1	X	X	0	0	0	X
FR2	0	X	X	0	X	0
FR3	0	0	X	X	X	X

DP1(a)	DP2	DP3
DP1(a)	DP2	DP4
DP1(a)	DP2	DP5
DP1(a)	DP3	DP2
DP1(a)	DP3	DP4
DP1(a)	DP3	DP5
DP1(a)	DP4	DP2
...	...	
...		
DP3	DP4	DP5

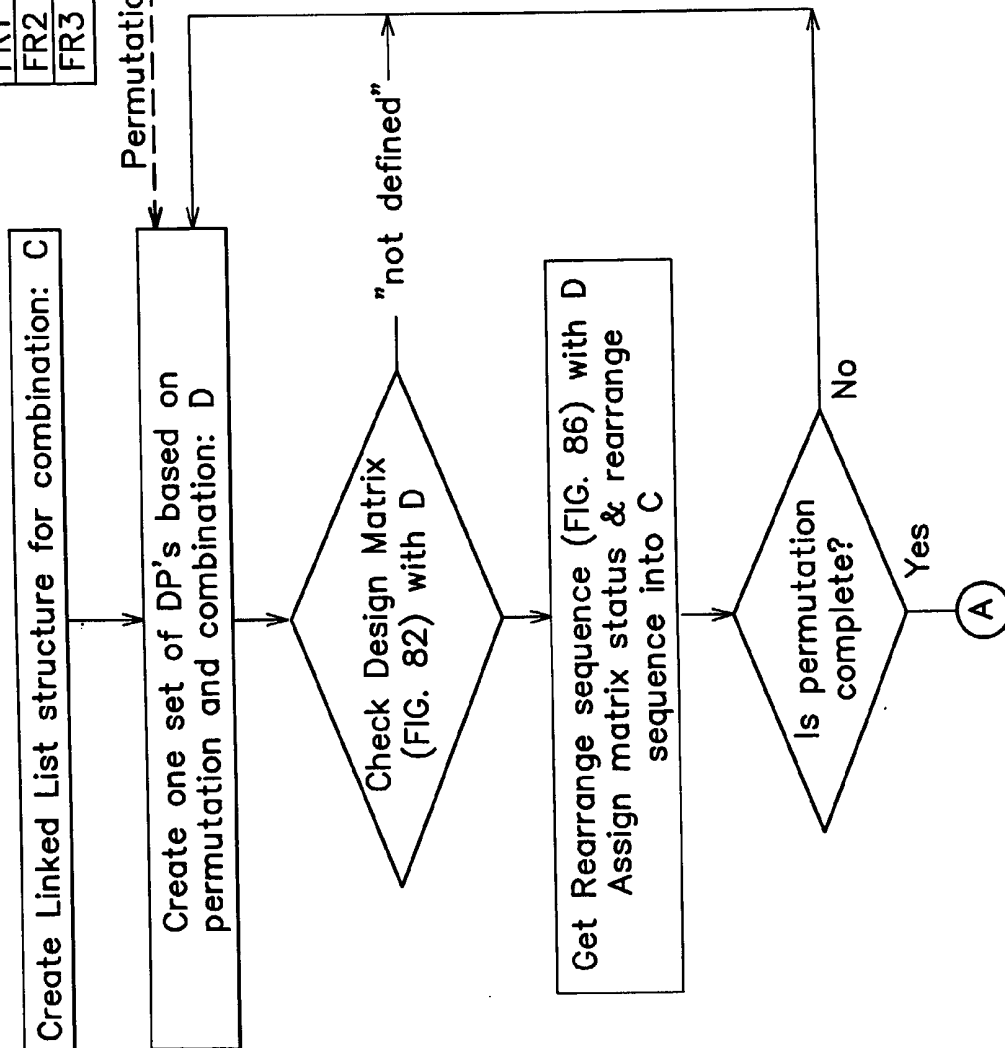

FIG. 88A

FIG. 88B

FIG. 88A

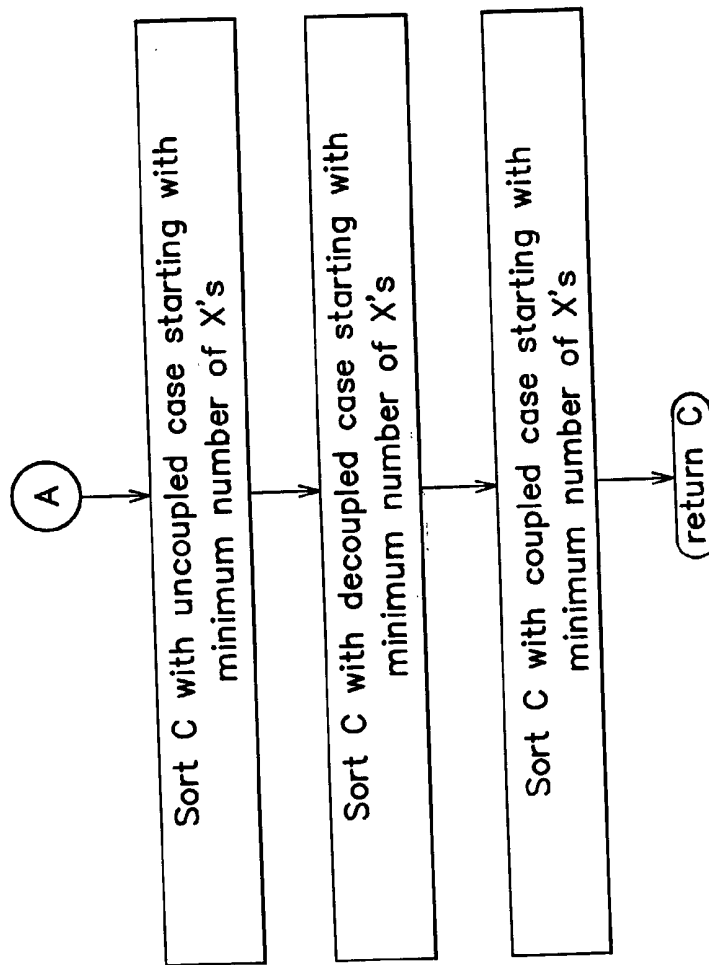

FIG. 88B

124/127

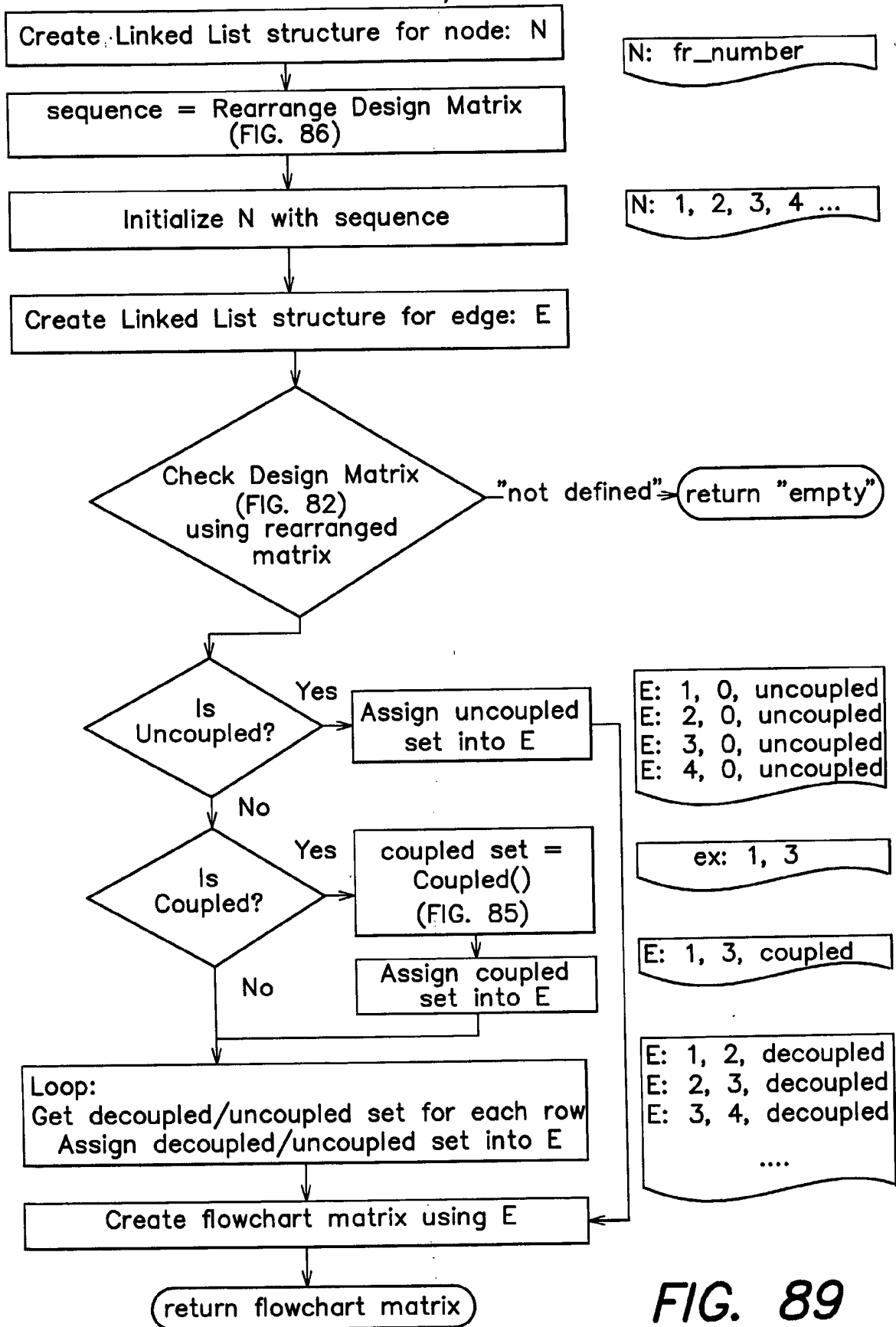

FIG. 89

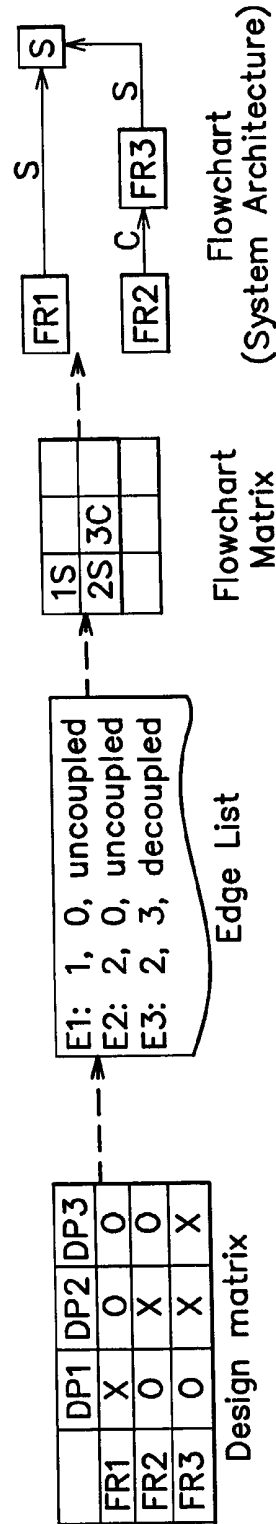

FIG. 90

126/127

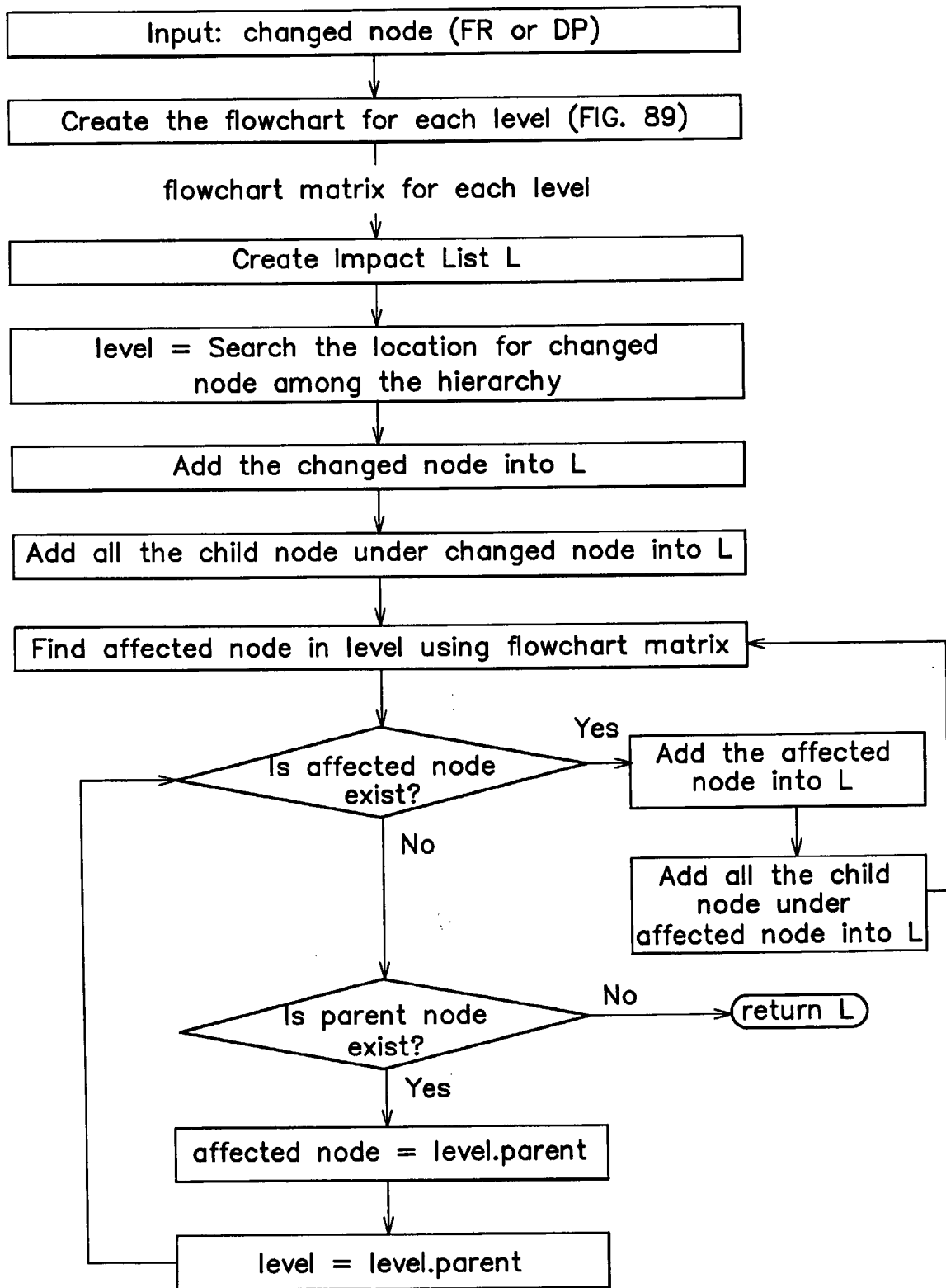

FIG. 91

127/127

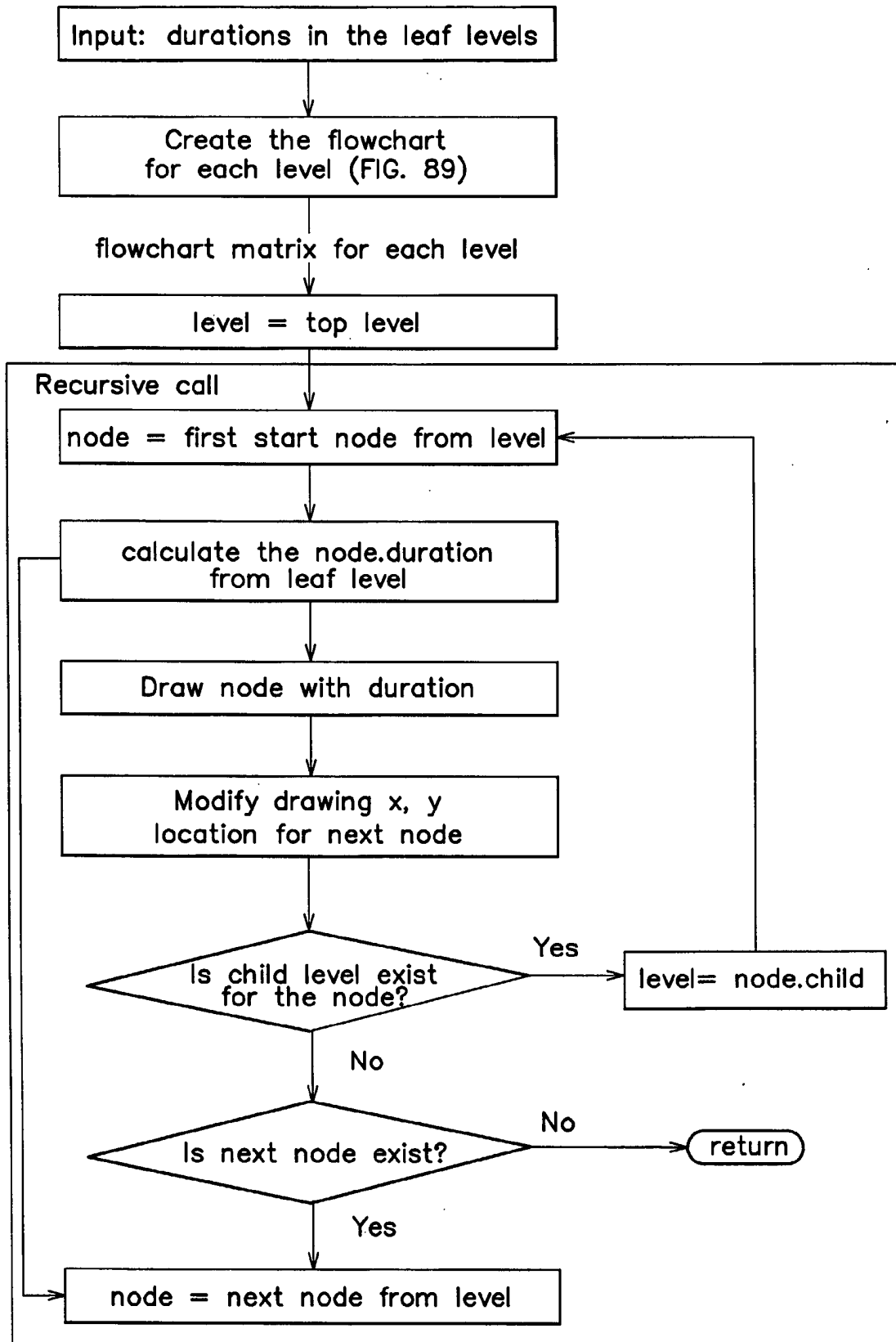

FIG. 92