



INTERNATIONAL APPLICATION PUBLISHED UNDER THE PATENT COOPERATION TREATY (PCT)

<p>(51) International Patent Classification ⁶ : A61M 37/00</p>	<p>A1</p>	<p>(11) International Publication Number: WO 98/51368 (43) International Publication Date: 19 November 1998 (19.11.98)</p>
<p>(21) International Application Number: PCT/US98/09527 (22) International Filing Date: 14 May 1998 (14.05.98) (30) Priority Data: 08/857,386 15 May 1997 (15.05.97) US (71) Applicant: VASCA, INC. [US/US]; Unit B3, 461 Boston Street, Topsfield, MA 01983 (US). (72) Inventors: BURBANK, Jeffrey, H.; 18 Sunrise Road, Boxford, MA 01921 (US). BRUGGER, James, M.; 5B Hillside Avenue, Newburyport, MA 01950 (US). (74) Agents: HESLIN, James, M. et al.; Townsend and Townsend and Crew LLP, 8th floor, Two Embarcadero Center, San Francisco, CA 94111-3834 (US).</p>		<p>(81) Designated States: AL, AM, AT, AU, AZ, BA, BB, BG, BR, BY, CA, CH, CN, CU, CZ, DE, DK, EE, ES, FI, GB, GE, GH, GM, GW, HU, ID, IL, IS, JP, KE, KG, KP, KR, KZ, LC, LK, LR, LS, LT, LU, LV, MD, MG, MK, MN, MW, MX, NO, NZ, PL, PT, RO, RU, SD, SE, SG, SI, SK, SL, TJ, TM, TR, TT, UA, UG, UZ, VN, YU, ZW, ARIPO patent (GH, GM, KE, LS, MW, SD, SZ, UG, ZW), Eurasian patent (AM, AZ, BY, KG, KZ, MD, RU, TJ, TM), European patent (AT, BE, CH, CY, DE, DK, ES, FI, FR, GB, GR, IE, IT, LU, MC, NL, PT, SE), OAPI patent (BF, BJ, CF, CG, CI, CM, GA, GN, ML, MR, NE, SN, TD, TG).</p> <p>Published <i>With international search report. Before the expiration of the time limit for amending the claims and to be republished in the event of the receipt of amendments.</i></p>

(54) Title: VALVE PORT ASSEMBLY WITH INTERLOCK

(57) Abstract

A dual port vascular access assembly (20) comprises a first access port (24) and a second access port (26). The linkage is coupled between the first access port (24) to close the second access port (26) in the absence of an access tube in the first access port (24). Such port assemblies are particularly useful for implantation in the patients receiving hemodialysis. By connecting the first access port (24) to the blood withdrawal side of the system (10), blood withdrawal will be automatically terminated upon cessation of blood returned to due loss of the return access tube in the port assembly.

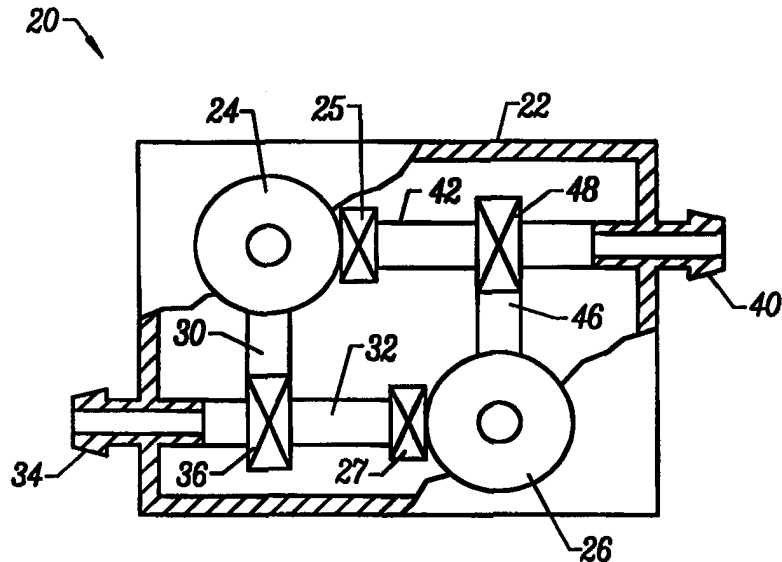

FOR THE PURPOSES OF INFORMATION ONLY

Codes used to identify States party to the PCT on the front pages of pamphlets publishing international applications under the PCT.

AL	Albania	ES	Spain	LS	Lesotho	SI	Slovenia
AM	Armenia	FI	Finland	LT	Lithuania	SK	Slovakia
AT	Austria	FR	France	LU	Luxembourg	SN	Senegal
AU	Australia	GA	Gabon	LV	Latvia	SZ	Swaziland
AZ	Azerbaijan	GB	United Kingdom	MC	Monaco	TD	Chad
BA	Bosnia and Herzegovina	GE	Georgia	MD	Republic of Moldova	TG	Togo
BB	Barbados	GH	Ghana	MG	Madagascar	TJ	Tajikistan
BE	Belgium	GN	Guinea	MK	The former Yugoslav Republic of Macedonia	TM	Turkmenistan
BF	Burkina Faso	GR	Greece			TR	Turkey
BG	Bulgaria	HU	Hungary	ML	Mali	TT	Trinidad and Tobago
BJ	Benin	IE	Ireland	MN	Mongolia	UA	Ukraine
BR	Brazil	IL	Israel	MR	Mauritania	UG	Uganda
BY	Belarus	IS	Iceland	MW	Malawi	US	United States of America
CA	Canada	IT	Italy	MX	Mexico	UZ	Uzbekistan
CF	Central African Republic	JP	Japan	NE	Niger	VN	Viet Nam
CG	Congo	KE	Kenya	NL	Netherlands	YU	Yugoslavia
CH	Switzerland	KG	Kyrgyzstan	NO	Norway	ZW	Zimbabwe
CI	Côte d'Ivoire	KP	Democratic People's Republic of Korea	NZ	New Zealand		
CM	Cameroon			PL	Poland		
CN	China	KR	Republic of Korea	PT	Portugal		
CU	Cuba	KZ	Kazakhstan	RO	Romania		
CZ	Czech Republic	LC	Saint Lucia	RU	Russian Federation		
DE	Germany	LI	Liechtenstein	SD	Sudan		
DK	Denmark	LK	Sri Lanka	SE	Sweden		
EE	Estonia	LR	Liberia	SG	Singapore		

5

VALVE PORT ASSEMBLY WITH INTERLOCK

BACKGROUND OF THE INVENTION

10 1. Field of the Invention

The present invention relates generally to the design and use of medical devices, and more particularly to the design and use of an implantable port assembly for establishing extracorporeal blood circulation for hemodialysis and other blood treatments.

Access to a patient's vascular system can be established by a variety of temporary and permanently implanted devices. Most simply, temporary access can be provided by the direct percutaneous introduction of a needle through the patient's skin and into a blood vessel. While such a direct approach is relatively simple and suitable for certain applications, such as intravenous feeding, intravenous drug delivery, and which are limited in duration, they are not suitable for hemodialysis and other extracorporeal procedures that must be repeated periodically, often for the lifetime of the patient.

For hemodialysis and other extracorporeal treatment regimens, a variety of implantable ports have been proposed over the years. Typically, the port includes a chamber and an access region, such as a septum, where the chamber is attached to an implanted catheter which in turn is secured to a blood vessel. In the case of veins, the catheter is typically indwelling and in the case of arteries, the catheter may be attached by conventional anastomosis.

Of particular interest to the present invention, needles and other access tubes may be percutaneously attached to an implanted port in several ways. Implantable ports often include a needle-penetrable septum which permits the

percutaneous penetration of a needle into the internal chamber. The chamber, in turn, is connected to one end of the implanted catheter, and the other end of the catheter is indwelling in or otherwise attached to the blood vessel.

5 Instead of a septum, the use of needle-actuated valve mechanisms in subcutaneously implanted ports has also been proposed. See, for example, U.S. Patent No. 5,527,278, and copending provisional application Serial No. 60/036,124, filed on January 21, 1997 (attorney docket no. 17742-000600), the
10 latter of which is assigned to the assignee of the present invention and is incorporated herein by reference. Both the septum ports and valve ports are most commonly provided in single-port assemblies, thus requiring two separate valve ports to establish access for blood extracorporeal
15 circulation. The use of dual-port assemblies for establishing both blood access and blood return has also been proposed. See, for example, Figs. 3 and 4 in U.S. Patent No. 5,527,278.

A rare but serious risk in performing hemodialysis and other extracorporeal blood circulation procedures results from accidental disconnection of the blood return needle from
20 the implanted blood return port. Because blood is usually returned to the patient on the low pressure, venous side of the vasculature, the extracorporeal circulation system (e.g., a dialysis machine) will not necessarily be able to detect any
25 pressure change if a venous return needle is accidentally dislodged and lost from the patient's vein. The pressure sensed by the extracorporeal circulation system results primarily from the needle itself, so alarms built in to the circulation system are usually insufficient. Thus, since
30 blood will continue to be drawn from the arterial side of the vasculature, the patient is at significant risk of losing large amounts of blood and even death.

For these reasons, it would be desirable to provide apparatus, systems, and methods which will reduce the risk of
35 continued blood withdrawal during extracorporeal blood recirculation protocols in the event that the blood return needle or device becomes dislodged. In particular, it would be desirable to provide implantable port assemblies where the

blood access or supply port is automatically closed in response to loss of the needle from the blood return port. Such assemblies could be in the form of dual port valve assemblies present in a single base or enclosure, or could be
5 in the form of separately implantable single port valve assemblies where mechanical, fluid, or other coupling is provided for the interlock. The interlock provided will preferably be simple, reliable, and operate in a fail safe manner. Optionally, the port assemblies and methods may also
10 provide for closure of the blood access port and the blood return ports on loss of the either the blood return needle or the blood access needle from the patient. At least some of the above objectives will be met by the different aspects of the present invention discussed below.

15
2. Description of the Background Art

Dual port vascular access assemblies are described in a number of U.S. Patents. U.S. Patent Nos. 5,527,278; 5,527,277; 5,503,630; 5,476,451; 5,417,656; and 5,281,199,
20 describe a dual port assembly suitable for performing hemodialysis. U.S Patent No. 4,108,173, describes dual port assemblies for withdrawing or introducing fluids from a single vessel. U.S. Patent Nos. 5,399,168; 5,360,407; 5,167,638; and 4,692,146, describe dual port assemblies which are connected
25 to blood vessels through a common lumen.

SUMMARY OF THE INVENTION

The present invention provides improved access port assemblies, apparatus, and methods which are useful for
30 providing the simultaneous withdrawal and return of blood to a patient, usually while performing therapies requiring extracorporeal blood circulation, such as hemodialysis, hemofiltration, hemodiafiltration, apheresis, and the like. The apparatus and systems of the present invention will
35 comprise a dual-port valve assembly or system including a first access port and a second access port. The first access port is connectable to a blood vessel or to a conduit which is connectable to a blood vessel. Similarly, the second access

port is connectable to a blood vessel or to a conduit which is connectable to a blood vessel. The ports are accessible using needles or other access tubes which are percutaneously introduced and which establish a fluid connection with the blood vessel, optionally via the conduit. According to the present invention, a linkage or other interlock mechanism is provided which is coupled to the first access port and which closes the second access port in the absence of a needle or other access tube within the first access port. Thus, by relying on the first access port for blood return to the patient and the second access port for blood supply (to the extracorporeal circuit), the risk of continuing to draw blood from the second access port if the return tube is accidentally dislodged from the first access port is substantially reduced or eliminated.

In preferred aspects of the dual port valve assembly, the first linkage will also close the first access port when the return tube is absent from the first access port. In another preferred aspect, a second linkage may be provided which is coupled to the second access port and which closes both the first access port and the second access port in the absence of an access tube (in this case the blood withdrawal tube which supplies blood to the extracorporeal treatment system) in the second access port.

The dual port valve assembly will usually include all of its components within a single enclosure, referred to here and after as a "base." The components, however, may be separate in the form of a system with the first access port and second access port being separately implantable and connected by a mechanical or hydraulic linkage which is itself implanted between the two access ports. The nature of the linkage is not critical and can take virtually any form which senses the presence of an access tube within the access port and which is able to close either or both of the linked access ports whenever the access tube is removed therefrom. In a particularly preferred aspect, the linkage will be self-closing, i.e. insertion of a needle or other access tube will open the linked access port(s) against a spring or other

force. When the access tube is removed, the port(s) will return to their normally closed configuration.

The first and second access ports will usually be connected to an artery as the blood supply source and a vein as the blood return, but other configurations are also possible. For example, the first and second access ports may be connected to a single blood vessel via a single, two-lumen conduit or via a pair of separate conduits. Alternatively, separate conduits may be used to connect to a vein as a blood supply source and an artery as a blood return source, although this will usually be the least preferred configuration.

In a specific embodiment of the present invention, the dual port valve assembly comprises a base having a venous passage for percutaneously receiving a venous access tube and an arterial passage for percutaneously receiving an arterial access tube. A venous conduit is disposed within the base to establish blood flow with the venous access tube which is inserted through the venous port. Similarly, an arterial conduit is disposed within the base to establish blood flow with the arterial access tube which is inserted through arterial port. A first linkage assembly is also disposed within the base and opens the arterial conduit when the venous access tube is present in the venous passage and closes the arterial conduit when the venous access tube is removed from the venous passage. Preferably, the first linkage assembly will also open the venous conduit when the venous access tube is present in the venous passage and close the venous conduit when the venous access tube is removed from the venous passage. Optionally, a second linkage assembly may be provided which opens the arterial conduit when the arterial access tube is present in the arterial passage and which closes the arterial conduit when the arterial access tube is removed from the arterial passage. Usually, the second valve assembly will also open the venous conduit when the arterial access tube is present in the arterial passage and close the venous conduit when the arterial access tube is removed from the venous passage.

Typically, the venous and arterial conduits comprise flexible, usually elastomeric, tubes and the linkage assemblies comprise clamps or "pinch valve" mechanisms which are spring-loaded to close the tube in the absence of an access tube in the associated access port. The flexible conduits may be adapted for direct connection to a blood vessel, may have a luer fitting or other standard connection at their distal ends, or may terminate in a fitting on the base of the valve assembly.

The present invention further provides for improved dual port valve assemblies of the type comprising a base, a first access port for receiving an access tube, a second access port for receiving an access tube, a first outlet fluidly connected to the first access port, and a second outlet fluidly coupled to the second access port, wherein the improvement comprises an interlock mechanism which prevents flow between the first access port and the first outlet when there is no access tube present in the second access port.

The present invention still further provides methods for establishing extracorporeal blood circulation for a patient's vasculature. Such methods comprise inserting a first access tube, such as a needle, into a first subcutaneous port to withdraw blood from a blood vessel and transfer such blood into extracorporeal circulation, such as hemodialysis, hemofiltration, hemodiafiltration, apheresis, or the like. A second access tube is inserted into a second subcutaneous port to return blood from such extracorporeal circulation. The method particularly comprises terminating the withdrawal blood from the first subcutaneous port in the event that the second (return) access tube is disconnected from the second access port. Usually, the first subcutaneous access port is attached to an artery and the second subcutaneous access port is connected to a vein, but other combinations are possible as described above. The terminating step preferably comprises actuating a linkage between the first access port and the second access port, wherein the linkage usually closes a conduit which connects the blood vessel to the first subcutaneous port. Typically, insertion of the first access

tube into the first subcutaneous port will also cause opening of the second access tube, usually against a spring or other stored-energy mechanism, so that subsequent removal of the access tube will result in immediate reclosing of the second access port in a "fail safe" manner. In preferred aspects of the method, the linkage also closes conduit which connects the blood vessel to the second subcutaneous port, and the method further comprises actuating a second linkage which closes both the first and second access ports in the event that the first access tube is disconnected from the first access port.

When blood withdrawal from the first subcutaneous port terminates as a result of disconnection of the second (return) access tube from the second access port, the extracorporeal circulation system, e.g. dialysis machine, will preferably be able to monitor and detect the flow termination, typically by detecting a decrease in pressure in the first access tube which is connected to the first access port. The pressure decrease, of course, will typically result from closure of the first access port in the manner described above.

BRIEF DESCRIPTION OF THE DRAWINGS

Fig. 1 is a schematic illustration of an extracorporeal blood circulation system employing the dual port valve assembly of the present invention.

Fig. 2 is a schematic plan view of a dual port valve assembly according to the present invention.

Fig. 3 is a plan view of a dual port valve assembly with portions broken away to show the internal valve passages.

Fig. 4 is cross-sectional view of the valve of Fig. 3 taken along line 4-4 of Fig. 3.

Fig. 5 is a cross-sectional view similar to Fig. 4, except that an access needle is present in a first port.

Fig. 6 is a cross-sectional view similar to Figs. 4 and 5, except that access needles are present in both the first and second ports.

DESCRIPTION OF THE SPECIFIC EMBODIMENTS

The present invention provides methods and apparatus for establishing percutaneous access to a patient's blood vessels, including both arterial blood vessels and venous blood vessels, for the purpose of establishing extracorporeal circulation for a variety of therapeutic procedures, as described below. Access port assemblies and systems according to the present invention comprise two ports which are implanted subcutaneously so that a "passage" therein lies a short distance beneath the surface of the patient's skin, typically being within 3 mm to 20 mm of the skin's surface. An access tube may then be percutaneously inserted into the passage in each of the access ports in order to provide connections to the blood vessels via the access ports. Extracorporeal circulation can thus be established for any blood treatment which requires continuous or even intermittent blood circulation, such as hemodialysis, any hemofiltration, hemodiafiltration, apheresis, and the like. In addition to extracorporeal treatment, the dual access port assemblies of the present invention can be used for perfusing drugs, fluids, and other materials directly into a patient's circulation for a variety of purposes.

The present invention relies on implantation of the dual access port assemblies and connection of the assemblies to the target blood vessel(s) via conduit(s), at least a portion of which will usually be flexible. By "flexible," it is meant that the conduit will be resilient and collapsible so that it may be externally clamped, pinched, or otherwise deformed in order to prevent blood flow through the conduit when the access port is to be closed. The use of external clamping to close the conduit is particularly advantageous since no internal structure need be provided within the conduit which could interfere with blood flow and/or with insertion of a needle or other access tube into the conduit.

The access tube will usually be a needle which can be directly pierced (percutaneously introduced) through the patient's skin and into the implanted port. Thus, the needle will usually have a sharpened tip in order to permit it to be

self-introduced through the skin. Of course, access tubes having blunt distal ends could be used by first piercing the skin with a separate blade, stylet, needle, or the like, and thereafter introducing the access tube into the resulting
5 incision or hole. The access tube could also be introduced using an internal stylet which is subsequently withdrawn, leaving the tube in place in the port. Generally, the needle or other access tube will possess sufficient column strength in order to actuate a linkage for relieving clamping of the
10 conduit, usually being a rigid metallic or plastic needle or cannula, as described in more detail below.

Referring now to Fig. 1, an extracorporeal blood treatment apparatus 10, such as a hemodialysis machine, is connected to a patient P using a blood withdrawal line 12 and
15 a blood return line 14. An access tube 16 at the distal end of the blood withdrawal line 12 is percutaneously introduced in a subcutaneous port which has been previously implanted in the patient. Similarly, an access tube 18 at the distal end of the blood return line 14 is percutaneously introduced into
20 a separate subcutaneous access port which has previously implanted into the patient. The details and preferred constructions of the subcutaneous access ports will be described in more detail below.

The present invention is particularly concerned with
25 the situation where the blood return line 14 becomes accidentally dislodged or removed from the associated subcutaneous port, as shown in broken line in Fig. 1. In such circumstances, the extracorporeal treatment apparatus 10 will usually be unable to detect that blood flowing through the
30 return line 14 is being spilled into the environment and not being returned to the patient. Thus, unless the dislodgement of the blood return line 14 is noticed by the patient or operator, and the system turned off, the patient is at risk of excessive blood loss since blood will continue to be drawn
35 from the patient through blood withdrawal line 12 by the apparatus 10. The present invention is particularly intended to prevent such accidental blood loss by terminating blood

flow from the access port connected to the blood withdrawal line 12.

The present invention relies on providing an interlock between the withdrawal and return access ports so that blood flow through the withdrawal access port is stopped as a direct consequence of removal of the access tube 16 from the blood return access port. The interlock is preferably mechanical, as described in detail below, but could also be hydraulic, electrical, or the like. Moreover, the various components of the access ports will typically be combined in a single enclosure, referred to herein after as a "base." The assemblies and systems of the present invention, however, could also comprise separate components which could be independently implanted in the patient and interconnected in various ways to provide the desired interlock.

An exemplary dual port valve assembly 20 constructed in accordance with the principles of the present invention is schematically illustrated in Fig. 2. The dual port valve assembly 20 comprises a base 22 having a first access port 24 and second access port 26 therein. Each of the access ports 24 and 26 will be configured to receive an access tube which may take the form of a needle or any of the other structures described above. Preferably, the access ports 24 and 26 will comprise mechanical valve assemblies 25 and 27, respectively, which open and close in response to insertion of the access tube, generally as described in copending provisional application Serial No. 60/036,124, filed January 21, 1997, the full disclosure of which has previously been incorporated herein by reference. The access port assemblies of the present invention, however, are not limited to mechanical valves, and could also comprise ports 24 and 26 which are formed from penetrable membranes or other conventional needle-access structures.

The present invention requires at least that the absence and/or removal of an access tube from the first access port 24 result in closure of the second access port 26. In dual port valve assembly 20, this is accomplished by a first linkage 30 between the first access port 24 and a conduit 32

which extends from the second access port 26 to an outlet connector 34 on the exterior of the base 22. Usually, the first linkage 30 will be a mechanical linkage which opens a "normally closed" clamp 36 which will close the conduit 32 when the access tube is removed to prevent blood flow from port 26. Thus, the connector 34 may be connected to a blood vessel, typically an artery, to act as a blood supply through port 26. In that case, a second connector 40 which is connected to the first port 24 through conduit 42 will act to return blood to the patient from the extracorporeal treatment system 10.

While the present invention is particularly directed at stopping the withdrawal blood from the patient in the event that the return access tube has been dislodged, the methods and systems will usually provide for stopping flow to and from both access ports in the event that either of the access tubes is lost from either of the access ports. As illustrated in Fig. 2, a second linkage assembly 46 is provided between the second port 26 and the second conduit tube 42. Linkage 46 has a clamp 48 or other closure mechanism which is opened by the presence of an access tube at port 26 and closed by the absence of an access tube in port 26. Port 26 will preferably further include an internal valve mechanism for closing itself when the access tube is lost, as described in copending provisional application Serial No. 60/036,124. Thus, the dual port valve assembly 20 will provide for closing both access ports 24 and 26 in the event either access tube is lost.

Referring now to Figs. 3-6, (Figs. 4-6 are cross-sectional views taken along line 4-4 in Fig. 3) a specific embodiment of the dual port valve assembly 100 comprises a base enclosure 102 and having a first access port 104 and a second access port 106. The base enclosure 102 has a first connector 108 adapted to be removably secured to an implantable cannula which may in turn be attached to an artery or vein in the manner described in the previously incorporated provisional application Serial No. 60/036,124. A second connector 110 is also provided for connection to an artery or vein in the same manner. The first connector 108 on the base

enclosure is fluidly coupled to the first port 104 by a segmented lumen 112 having four segments 112a-112d within the base enclosure 102. The first segment 112a is coaxially aligned within the first connector 108 and extends inwardly to a vertically reciprocatable valve piston 114. The valve piston 114 includes the second lumen segment 112b therein, where the segments 112a and 112b are out of alignment when the valve piston 114 is raised, as shown in Fig. 5. When the valve piston 114 is lowered, however, as shown in Fig. 6, the segments 112a and 112b will be aligned to permit blood flow therethrough.

The third lumen segment 112c is disposed in the middle of the base enclosure 102 and is aligned with the first segment 112a. In this way, when the valve piston 114 is raised, continuity between lumen segment 112a and lumen segment 112c is broken. When the valve piston 114 is lowered, however, continuity between segments 112a and 112c is established to permit blood flow therethrough.

The fourth lumen segment 112d is disposed in a second vertically reciprocatable valve piston 116 which is aligned with the first port 104, as best seen in Fig. 4. Lumen segment 112d is L-shaped and is aligned with the third lumen segment 112c when valve piston 116 is in its lowered position, as shown in Figs. 5 and 6. When the valve piston 116 is raised, as shown in Fig. 4, the fourth lumen segment 112d is out of alignment with the third lumen segment 112c so that flow is blocked between the first port 104 and the first connector 108. As described thus far, it can be seen that, in order to establish flow from the first port 104 to the first connector 108 (or vice versa), both the valve pistons 114 and 116 must be in their lowered position. It should be noted that a similar four-segment lumen 118 is provided between the second connector 110 and the second port 106. Only two of the segments (third segment 118c and fourth segment 118d) are illustrated in Fig. 3. It will be further understood, however, that in order for the lumen 118 to be fully opened, both the valve pistons 114 and 116 must be in their lowered configuration, as illustrated in Fig. 6.

As will now be described, the valve pistons 114 and 116 are lowered by introducing access needles 120 and 122 into the first and second ports 104 and 106, respectively. As illustrated in Fig. 5, the first access needle 120 is passed into port 104 (which will require percutaneous passage since the port will be implanted) and engages a pair of adjacent balls 124. When the balls 124 are in their radially closed configuration, as seen in Fig. 4, they lie across the port 104. Thus, the needle 120 will engage the balls 124 and move them downward as the needle is depressed. As the balls 124 enter an enlarged portion 129 of chamber 130 within the base enclosure 102, they spread apart allowing the needle to enter the vertical segment of lumen segment 112d, as illustrated in Fig. 5. When the access needle 120 is removed, the valve piston 116 will return to its vertically raised position under the return force of springs 132 which are compressed as the valve piston is initially lowered.

Valve piston 114 is similarly lowered by introducing an access needle 122 through port 106 (Fig. 6). The access needle 122 enters the vertical leg of fourth lumen segment 118b, spreads balls 125, and lowers the valve piston 114 in the manner analogous to that just described for valve piston 116. Thus, when both access needles 120 and 122 are fully introduced into the dual access port 100, the valve pistons 114 and 116 are both lowered, and both of the segmented lumens 112 and 118 are aligned and fully opened. Of critical importance to the present invention, when either needle 120 or 122 is removed, either intentionally or accidentally, the corresponding valve piston will raise under the force of the associated springs 132, thus closing one segment in each of segmented lumens 112 and 118, and completely blocking flow through both lumens of the dual port valve.

While the above is a complete description of the preferred embodiments of the invention, various alternatives, modifications, and equivalents may be used. Therefore, the above description should not be taken as limiting the scope of the invention which is defined by the appended claims.

WHAT IS CLAIMED IS:

1 1. A dual port valve assembly comprising:
2 a first access port connectable to a conduit or
3 a blood vessel;
4 a second access port connectable to a conduit
5 or a blood vessel; and
6 a linkage coupled to the first access port
7 which closes the second access port in absence of an access
1 tube in the first access port.

1 2. A dual port valve assembly as in claim 1,
2 wherein the linkage also closes the access port in the absence
3 of a tube in the first access port.

1 3. A dual port valve assembly as in claim 2,
2 further comprising a linkage coupled to the second access port
3 which closes the first access port and the second port in the
4 absence of an access tube in the second access port.

1 4. A dual port valve assembly comprising:
2 a base having a venous passage for receiving a
3 venous access tube and an arterial passage for receiving an
4 arterial access tube;
5 a venous conduit disposed to establish blood
6 flow with the venous access tube inserted through the venous
7 port;
8 an arterial conduit disposed to establish blood
9 flow with the arterial access tube inserted through the
10 arterial port; and
11 a first linkage assembly which opens the
12 arterial conduit when the venous access tube is present in the
13 venous passage and which closes the arterial conduit when the
14 venous access tube is removed from the venous passage.

1 5. A dual port valve assembly as in claim 4,
2 wherein the first linkage assembly also opens the venous
3 conduit when the venous access tube is present in the venous
4 passage and closes the venous conduit when the venous access
5 tube is removed from the venous passage.

1 6. A dual port valve as in claim 5, wherein the
2 venous and arterial conduits each have a proximal end disposed
3 within the base and a distal end disposed outside of the base.

1 7. A dual port valve as in claim 6, wherein the
2 distal ends of the conduits are adapted for direct connection
3 to a blood vessel.

1 8. A dual port valve as in claim 6, wherein the
2 distal ends of the conduits are adapted for connection to one
3 end of a catheter.

1 9. A dual port valve as in claim 6, wherein the
2 distal ends of the conduits terminate in a luer connector.

1 10. A dual port valve as in claim 6, wherein the
2 venous and arterial conduits each have a proximal end disposed
3 within the base and a distal end which terminates at a
4 connector on an external surface of the base.

1 11. A dual port valve as in claim 5, wherein the
2 first linkage assembly is disposed wholly within the base.

1 12. A dual port valve as in claim 5, wherein the
2 linkage is actuated by passage of the venous access tube into
3 the venous passage which results in release of a clamp from
4 the exterior of the arterial and venous conduits.

1 13. A dual port valve as in claim 5, wherein the
2 venous passage comprises a tapered bore which seals against
3 the venous access tube as said tube is inserted therein.

1 14. A dual port valve as in claim 13, wherein the
2 venous conduit is attached to a small diameter and of the
3 tapered bore.

1 15. A dual port valve as in claim 14, wherein the
2 venous conduit is attached to the tapered bore at an angle
3 from 75° to 105°.

1 16. A dual port valve assembly as in claim 5,
2 further comprising a second linkage assembly which opens the
3 arterial conduit when the arterial access tube is present in
4 the arterial passage and which closes the arterial conduit
5 when the arterial access tube is removed from the arterial
6 passage.

1 17. A dual port valve assembly as in claim 16,
2 wherein the second linkage assembly also opens the venous
3 conduit when the arterial access tube is present in the
4 arterial passage and closes the venous conduit when the
5 arterial access tube is removed from the venous passage.

1 18. A dual port valve assembly as in claim 17,
2 wherein the venous and arterial conduits each have a proximal
3 end disposed within the base and a distal end disposed outside
4 the base.

1 19. A dual port valve assembly as in claim 18,
2 wherein the distal ends of the conduits are adapted for direct
3 connection to a blood vessel.

1 20. A dual port valve assembly as in claim 18,
2 wherein the distal ends of the conduits are adapted for
3 connection to one end of a catheter.

1 21. A dual port valve assembly as in claim 18,
2 wherein the distal ends of the conduits terminate in a luer
3 connector.

1 22. A dual port valve assembly as in claim 17,
2 wherein the venous and arterial conduits each have a proximal
3 end disposed within the base and a distal end which terminates
4 at a connector on an external surface of the base.

1 23. A dual port valve assembly as in claim 17,
2 wherein the second linkage assembly is disposed wholly within
3 the base.

1 24. A dual port valve assembly as in claim 17,
2 wherein the second linkage is actuated by passage of the
3 arterial access tube into the arterial passage which results
4 in release of a clamp from the exterior of the arterial and
5 venous conduits.

1 25. A dual port valve assembly as in claim 17,
2 wherein the arterial passage comprises a tapered bore which
3 seals against the arterial access tube as said tube is
4 inserted therein.

1 26. A dual port valve assembly as in claim 25,
2 wherein the arterial conduit is attached to a small diameter
3 and of the tapered bore.

1 27. A dual port valve assembly as in claim 26,
2 wherein the arterial conduit is attached to the tapered bore
3 at an angle from 75° to 105°.

1 28. An improved dual port valve assembly of the
2 type comprising a base, a first access port for receiving an
3 access tube, a second access port for receiving an access
4 tube, a first outlet fluidly connected to the first access
5 port, and a second outlet fluidly coupled to the second access
6 port, wherein the improvement comprises an interlock mechanism
7 which prevents flow between the first access port and the
8 first outlet which there is no access tube present in the
9 second access port.

1 29. A method for establishing extracorporeal blood
2 circulation from a patient's vasculature, said method
3 comprising:

4 (a) inserting a first access tube into a first
5 subcutaneous port to withdraw blood from a blood vessel into
6 extracorporeal circulation;

7 (b) inserting a second access tube into a second
8 subcutaneous port to return blood from extracorporeal
9 circulation; and

10 (c) terminating the withdrawal of blood from the
11 first subcutaneous port in the event that the second access
12 tube is disconnected from the second access port.

1 30. A method as in claim 29, wherein the first
2 subcutaneous port is attached to an artery and the second
3 subcutaneous port is connected to a vein.

1 31. A method as in claim 29, wherein step (c)
2 comprises actuating a linkage between the first access port
3 and the second access port.

1 32. A method as in claim 31, wherein the linkage
2 closes a conduit which connects the blood vessel to the first
3 subcutaneous port.

1 33. A method as in claim 32, wherein the linkage
2 also closes a conduit which connects the blood vessel to the
3 second subcutaneous port.

1 34. A method as in claim 33, further comprising
2 actuating a second linkage which closes the conduit connecting
3 the blood vessel to the first subcutaneous port in the event
4 that the first access tube is disconnected from the first
5 access port.

1 35. A method as in claim 34, wherein the second
2 linkage also closes the conduit which connects the blood
3 vessel to the second subcutaneous port.

1 36. An improved hemodialysis method of the type
2 wherein blood is withdrawn from a blood vessel through a first
3 implanted port and returned to the blood vessel through a
4 second implanted port, wherein the improvement comprises
5 interlocking the first port to the second port so that absence
6 of an access tube in the second port to return blood closes
7 the first port to stop the withdrawal of blood.

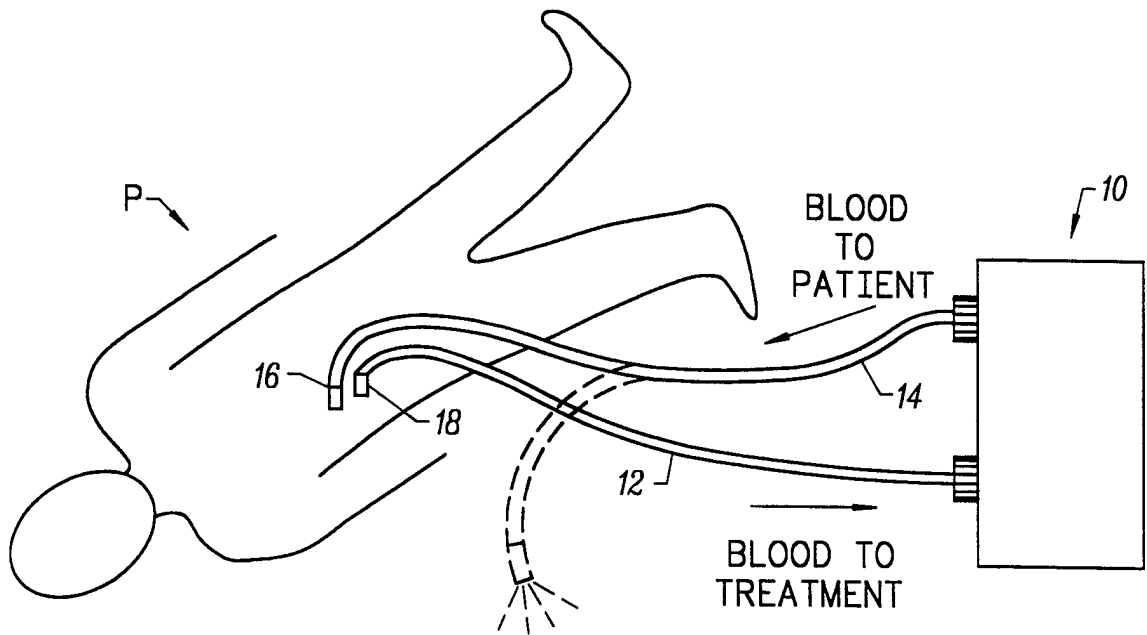

FIG. 1

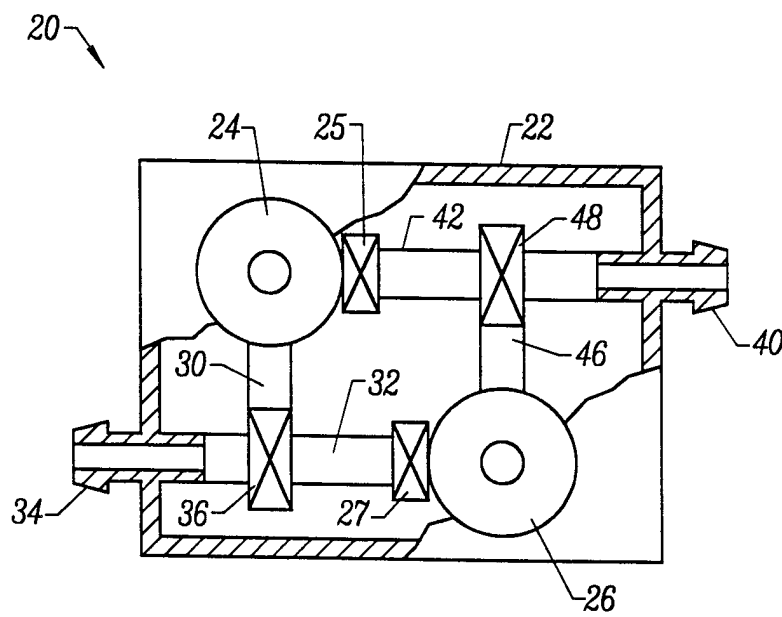

FIG. 2

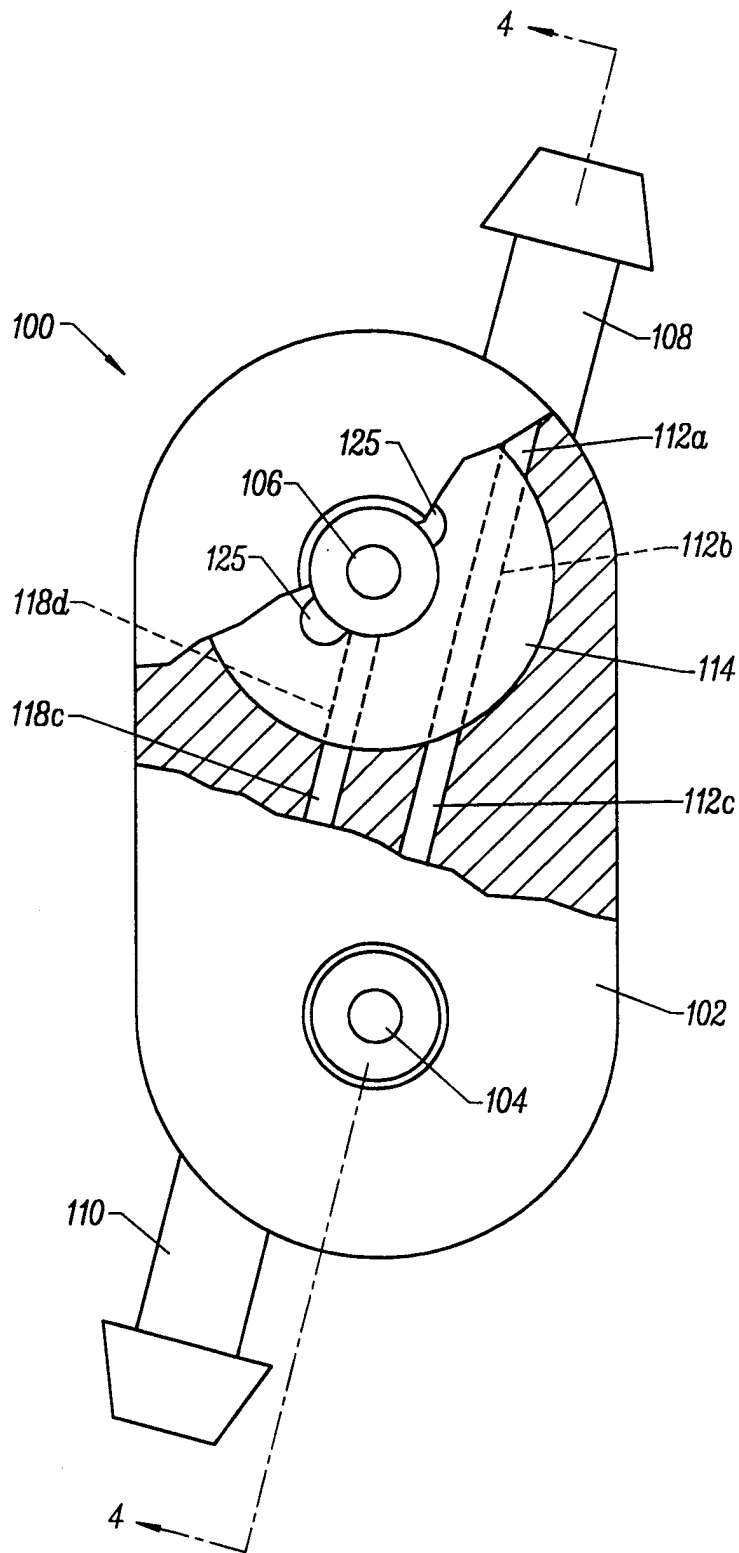

FIG. 3

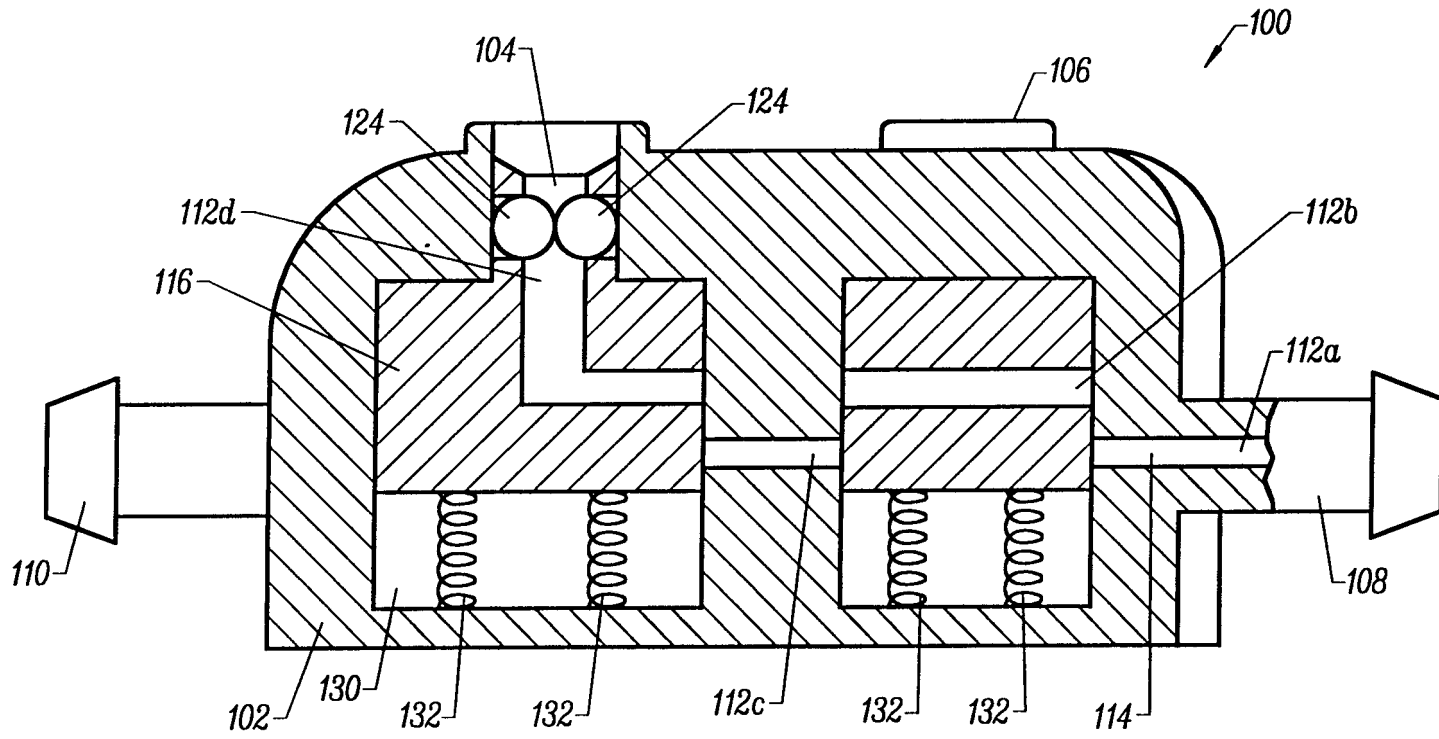

FIG. 4

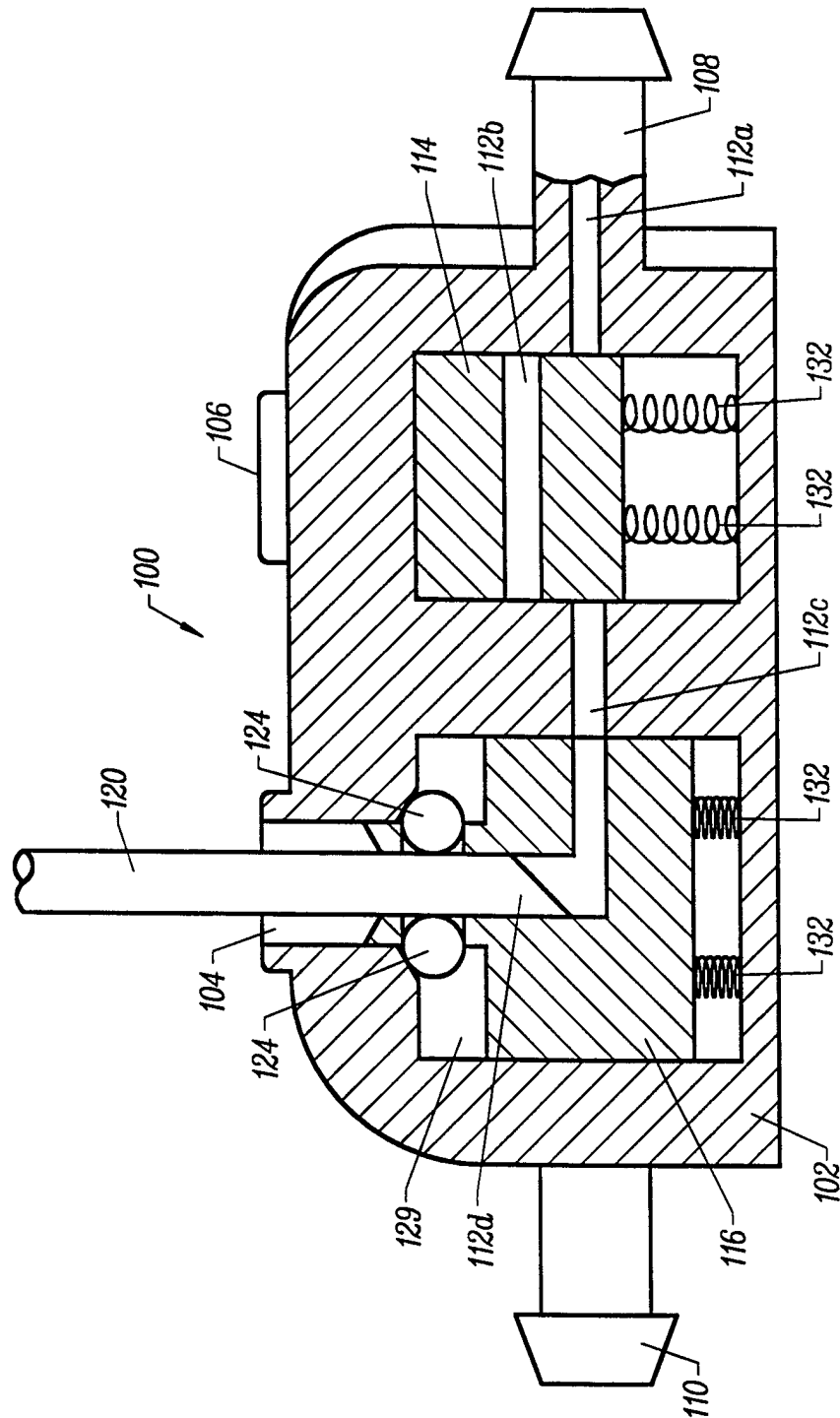

FIG. 5

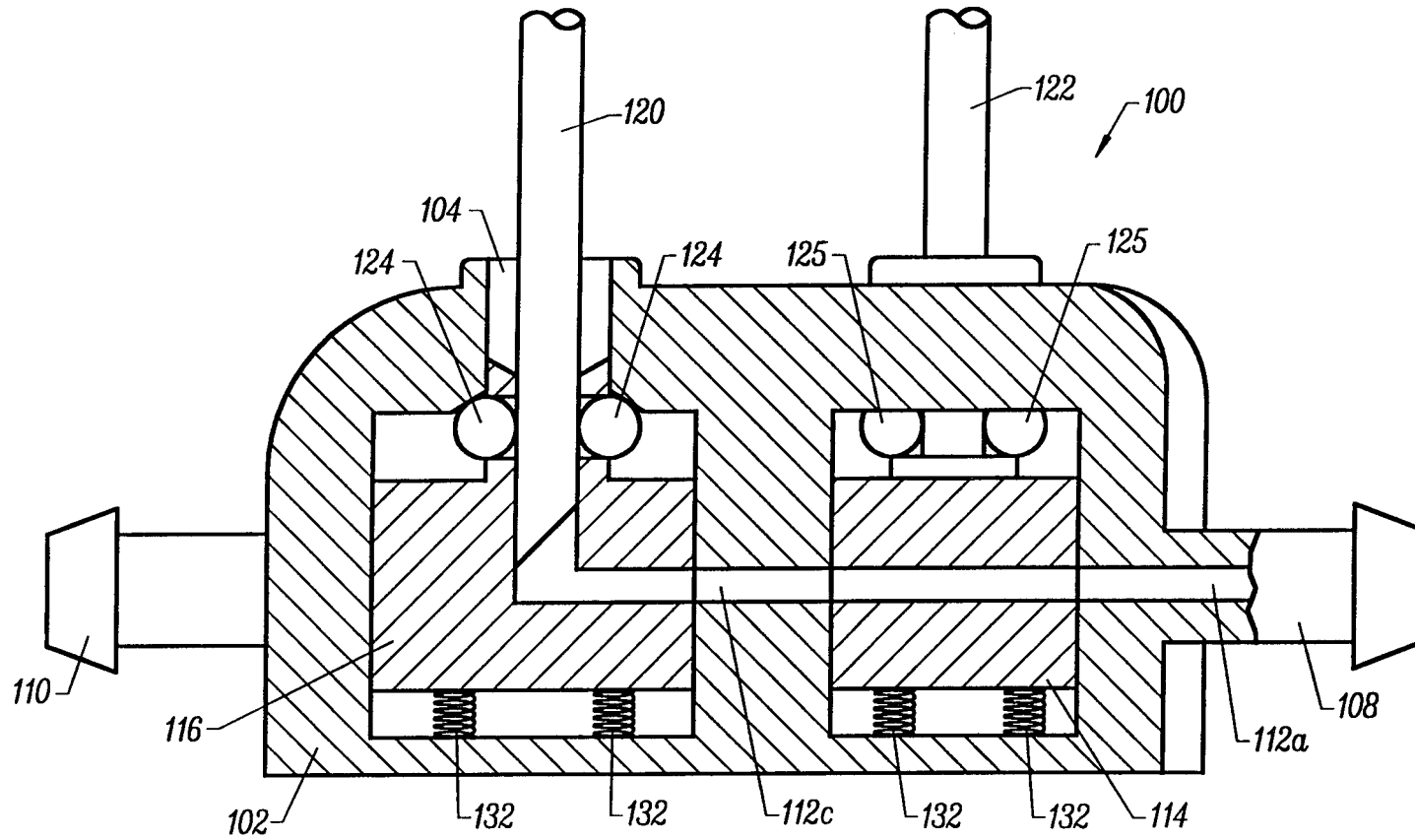

FIG. 6

INTERNATIONAL SEARCH REPORT

International application No.
PCT/US98/09527

A. CLASSIFICATION OF SUBJECT MATTER

IPC(6) :A61M 37/00
US CL :604/4

According to International Patent Classification (IPC) or to both national classification and IPC

B. FIELDS SEARCHED

Minimum documentation searched (classification system followed by classification symbols)

U.S. : 604/4

Documentation searched other than minimum documentation to the extent that such documents are included in the fields searched

Electronic data base consulted during the international search (name of data base and, where practicable, search terms used)

C. DOCUMENTS CONSIDERED TO BE RELEVANT

Category*	Citation of document, with indication, where appropriate, of the relevant passages	Relevant to claim No.
A	US 5,281,199 A (ENSMINGER et al) 25 January 1994, entire document.	1-36
A	US 5,476,451 A (ENSMINGER et al) 19 December 1995, entire document.	1-36

Further documents are listed in the continuation of Box C. See patent family annex.

* Special categories of cited documents:	*T* later document published after the international filing date or priority date and not in conflict with the application but cited to understand the principle or theory underlying the invention
"A" document defining the general state of the art which is not considered to be of particular relevance	"X" document of particular relevance; the claimed invention cannot be considered novel or cannot be considered to involve an inventive step when the document is taken alone
"E" earlier document published on or after the international filing date	"Y" document of particular relevance; the claimed invention cannot be considered to involve an inventive step when the document is combined with one or more other such documents, such combination being obvious to a person skilled in the art
"L" document which may throw doubts on priority claim(s) or which is cited to establish the publication date of another citation or other special reason (as specified)	"&" document member of the same patent family
"O" document referring to an oral disclosure, use, exhibition or other means	
"P" document published prior to the international filing date but later than the priority date claimed	

Date of the actual completion of the international search

29 AUGUST 1998

Date of mailing of the international search report

08 OCT 1998

Name and mailing address of the ISA/US
Commissioner of Patents and Trademarks
Box PCT
Washington, D.C. 20231

Facsimile No. (703) 305-3230

Authorized officer

KI YONG O

Telephone No. (703) 308-2681