



(51) International Patent Classification:

H01Q 21/00 (2006.01) H01Q 1/12 (2006.01)  
H01Q 19/00 (2006.01) H01Q 1/42 (2006.01)

(21) International Application Number:

PCT/US2019/040227

(22) International Filing Date:

02 July 2019 (02.07.2019)

(25) Filing Language:

English

(26) Publication Language:

English

(30) Priority Data:

62/694,316 05 July 2018 (05.07.2018) US  
62/829,171 04 April 2019 (04.04.2019) US

(71) Applicant: COMMSCOPE TECHNOLOGIES LLC

[US/US]; 1100 CommScope Place SE, Hickory, North Carolina 28602 (US).

(72) Inventors: BISIULES, Peter J.; 1427 Blanchan Ave, La-Grange Park, Illinois 60526 (US). VARNOOSFADER-

ANI, Mohammad Vatankhah; 10-12 Lexington Drive, Bella Vista, Sydney, New South Wales 2153 (AU).

(74) Agent: AYERS, Randal, D.; MYERS BIGEL, P.A., PO Box 37428, Raleigh, North Carolina 27627 (US).

(81) Designated States (unless otherwise indicated, for every kind of national protection available): AE, AG, AL, AM, AO, AT, AU, AZ, BA, BB, BG, BH, BN, BR, BW, BY, BZ, CA, CH, CL, CN, CO, CR, CU, CZ, DE, DJ, DK, DM, DO, DZ, EC, EE, EG, ES, FI, GB, GD, GE, GH, GM, GT, HN, HR, HU, ID, IL, IN, IR, IS, JO, JP, KE, KG, KH, KN, KP, KR, KW, KZ, LA, LC, LK, LR, LS, LU, LY, MA, MD, ME, MG, MK, MN, MW, MX, MY, MZ, NA, NG, NI, NO, NZ, OM, PA, PE, PG, PH, PL, PT, QA, RO, RS, RU, RW, SA, SC, SD, SE, SG, SK, SL, SM, ST, SV, SY, TH, TJ, TM, TN, TR, TT, TZ, UA, UG, US, UZ, VC, VN, ZA, ZM, ZW.

(84) Designated States (unless otherwise indicated, for every kind of regional protection available): ARIPO (BW, GH, GM, KE, LR, LS, MW, MZ, NA, RW, SD, SL, ST, SZ, TZ, UG, ZM, ZW), Eurasian (AM, AZ, BY, KG, KZ, RU, TJ, TM), European (AL, AT, BE, BG, CH, CY, CZ, DE, DK, EE, ES, FI, FR, GB, GR, HR, HU, IE, IS, IT, LT, LU, LV,

(54) Title: MULTI-BAND BASE STATION ANTENNAS HAVING RADOME EFFECT CANCELLATION FEATURES

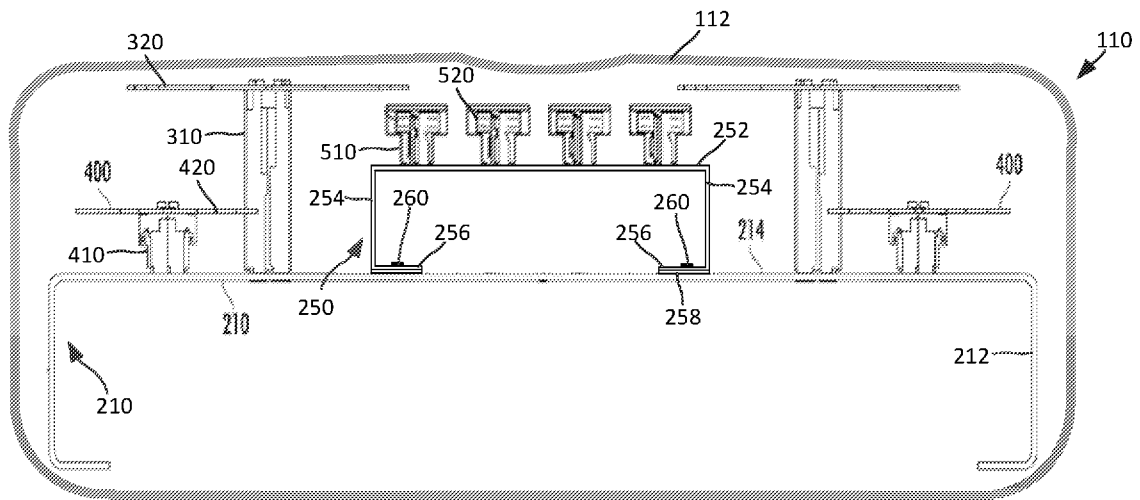

FIG. 3

(57) Abstract: A base station antenna includes a radome and an antenna assembly that is mounted within the radome. The antenna assembly includes a backplane that includes a first reflector, a first array that includes a plurality of first radiating elements mounted to extend forwardly from the first reflector, a second reflector mounted to extend forwardly from the first reflector and a second array that includes a plurality of second radiating elements mounted to extend forwardly from the second reflector. The first radiating elements extend a first distance forwardly from the first reflector and the second radiating elements extend a second distance forwardly from the second reflector, where the first distance exceeds the second distance.



MC, MK, MT, NL, NO, PL, PT, RO, RS, SE, SI, SK, SM,  
TR), OAPI (BF, BJ, CF, CG, CI, CM, GA, GN, GQ, GW,  
KM, ML, MR, NE, SN, TD, TG).

**Declarations under Rule 4.17:**

- *of inventorship (Rule 4.17(iv))*

**Published:**

- *with international search report (Art. 21(3))*
- *before the expiration of the time limit for amending the claims and to be republished in the event of receipt of amendments (Rule 48.2(h))*

MULTI-BAND BASE STATION ANTENNAS HAVING RADOME EFFECT  
CANCELLATION FEATURES

CROSS-REFERENCE TO RELATED APPLICATIONS

[0001] The present application is related to U.S. Provisional Patent Application Serial No. 62/829,171, filed April 4, 2019, and to U.S. Provisional Patent Application Serial No. 62/694,316, filed July 5, 2018, the entire content of each of which is incorporated herein by reference as if set forth fully herein.

BACKGROUND

[0002] The present invention generally relates to radio communications and, more particularly, to base station antennas for cellular communications systems.

[0003] Cellular communications systems are well known in the art. In a cellular communications system, a geographic area is divided into a series of regions or "cells" that are served by respective base stations. Each base station may include one or more base station antennas that are configured to provide two-way radio frequency ("RF") communications with subscribers that are within the cell served by the base station. In many cases, each base station is divided into "sectors." In one common configuration, a hexagonally-shaped cell is divided into three 120° sectors in the azimuth plane, and each sector is served by one or more base station antennas that have an azimuth Half Power Beamwidth (HPBW) of approximately 65°. Typically, the base station antennas are mounted on a tower or other raised structure, with the radiation patterns that are generated by the base station antennas directed outwardly. Base station antennas are often implemented as linear or planar phased arrays of radiating elements.

[0004] Conventionally, most cellular communications systems have operated in frequency bands that are at frequencies of less than 2.8 GHz. In order to accommodate the

increasing volume of cellular communications, a variety of new frequency bands are being assigned for cellular communications service. Some of the new frequency bands that are being introduced for cellular communications service are within the 3-6 GHz frequency range. The use of these frequency bands, which may be nearly an order of magnitude higher in frequency than some of the existing cellular frequency bands, may result in new challenges in base station antenna design, particularly in multi-band antennas that include linear arrays of radiating elements that are designed to operate in different frequency bands.

#### SUMMARY

[0005] Pursuant to embodiments of the present invention, base station antennas are provided that include a radome and an antenna assembly that is mounted within the radome. The antenna assembly includes a backplane that includes a first reflector and a second reflector that is mounted to extend forwardly from the first reflector. A first array that includes a plurality of first radiating elements are mounted to extend forwardly from the first reflector, and a second array that includes a plurality of second radiating elements are mounted to extend forwardly from the second reflector. The first radiating elements extend a first distance forwardly from the first reflector and the second radiating elements extend a second distance forwardly from the second reflector, where the first distance exceeds the second distance.

[0006] In some embodiments, the second reflector may be electrically connected to the first reflector. The electrical connection may be a direct galvanic connection or a capacitive connection.

[0007] In some embodiments, the first radiating elements may be mounted to extend forwardly from a first planar surface of the first reflector and the second radiating elements may be mounted to extend forwardly from a second planar surface of the second reflector. The first planar surface may extend in parallel to the second planar surface in some embodiments, and/or the second reflector may include a pair of lips that extend in parallel to the second planar surface.

[0008] In some embodiments, each second radiating element may include at least one radiator, and the second radiating elements may be mounted so that a front surface of the radome is within a near field of the radiators of the second radiating elements.

[0009] In some embodiments, the base station antenna may further include a third array that includes a plurality of third radiating elements that are mounted to extend forwardly from the first reflector. The first and third radiating elements may be configured to

operate in a first frequency band and the second radiating elements may be configured to operate in a second, higher, frequency band. In some embodiments, the second array may be positioned between the first array and the third array.

[0010] Pursuant to further embodiments of the present invention, base station antennas are provided that include a radome and an antenna assembly that is mounted within the radome. The antenna assembly includes a backplane having a stepped reflector that has at least a first front surface, a second front surface, and a sidewall disposed between the first front surface and the second front surface. The antenna assembly further includes a first array that has a plurality of first radiating elements that are mounted to extend forwardly from the first front surface and a second array that has a plurality of second radiating elements that are mounted to extend forwardly from the second front surface.

[0011] In some embodiments, the first front surface may be parallel to the second front surface.

[0012] In some embodiments, the second front surface may be closer to a front surface of the radome than is the first front surface. In such embodiments, the first radiating elements may be configured to operate in a first frequency band and the second radiating elements may be configured to operate in a second frequency band that is higher in frequency than the first frequency band.

[0013] In some embodiments, each second radiating element may include at least one radiator, and the second radiating elements may be mounted so that a front surface of the radome is within a near field of the radiators of the second radiating elements.

[0014] In some embodiments, the stepped reflector may further include a third front surface that is parallel to the second front surface and spaced apart from both the first front surface and the second front surface, and the base station antenna may further include a third array that has a plurality of third radiating elements that are mounted to extend forwardly from the third front surface.

[0015] In some embodiments, the stepped reflector may be a monolithic structure.

[0016] Pursuant to still further embodiments of the present invention, base station antennas are provided that include a radome and a backplane mounted within the radome. A linear array of radiating elements is mounted to extend forwardly from the backplane, each radiating element includes a feed stalk and a dipole radiator. Each radiator is mounted at a distance of approximately  $M \cdot \lambda / 4$  forwardly of the backplane, where  $M$  is an odd integer greater than 1 and  $\lambda$  is a wavelength corresponding to a center frequency of an operating frequency band of the dipole radiators. In some embodiments,  $M$  may be equal to 3, 5 or 7.

[0017] In some embodiments, each feed stalk may comprise a printed circuit board having a shielded transmission line thereon. The shielded transmission line may comprise, for example, a stripline transmission line or a coplanar waveguide transmission line.

[0018] In some embodiments, the radiating elements may be mounted so that a front surface of the radome is within a near field of the dipole radiators of the radiating elements.

[0019] In some embodiments, the linear array may be a first linear array of first radiating elements, and the base station antenna may further include a second linear array of second radiating elements that are configured to operate in a second frequency band. In such embodiments, dipole radiators of the second radiating elements may be mounted less than half a wavelength of a center frequency of the second operating frequency band forwardly from the backplane.

[0020] Pursuant to still further embodiments of the present invention, base station antennas are provided that include a radome and a reflector mounted within the radome. A linear array of radiating elements is mounted to extend forwardly from the reflector, where each radiating element includes a feed stalk and a dipole radiator. Each feed stalk has a length that is greater than  $\lambda/2$ , where  $\lambda$  is a wavelength corresponding to a center frequency of an operating frequency band of the dipole radiators.

#### BRIEF DESCRIPTION OF THE DRAWINGS

[0021] FIG. 1 is a perspective view of a base station antenna according to embodiments of the present invention.

[0022] FIG. 2 is a front view of the base station antenna of FIG. 1 with the radome removed.

[0023] FIG. 3 is a cross-sectional view of the base station antenna of FIG. 1.

[0024] FIG. 4 is a cross-sectional view illustrating a conventional technique for mounting radiating elements in a base station antenna.

[0025] FIG. 5 is a schematic cross-sectional diagram illustrating a backplane having a stepped reflector that may be used in place of the backplane and secondary reflector included in the base station antenna of FIGS. 1-3.

[0026] FIGS. 6A and 6B are schematic cross-sectional diagrams illustrating additional backplane designs that have stepped reflectors according to embodiments of the present invention.

[0027] FIG. 7 is a schematic perspective view of a radiating element according to embodiments of the present invention that has an extended feed stalk.

[0028] FIGS. 8A and 8B are azimuth radiation patterns that illustrate how a radome may impact the radiation pattern of a linear array of radiating elements.

#### DETAILED DESCRIPTION

[0029] Base station antennas typically include a radome that serves as at least part of an outer housing for the antenna. The radome may protect the interior components of the antenna from damage during shipping and installation, and from rain, ice, snow, moisture, wind, insects, birds, and other environmental factors once the base station antenna is installed for use. While base station antenna radomes may be formed of a variety of different materials, fiberglass radomes are the most common, as they are relatively lightweight, exhibit high mechanical strength and are reasonably inexpensive to manufacture.

[0030] Unfortunately, the radome of a base station antenna can negatively impact the RF signals transmitted by the radiating elements of the base station antenna. For example, a radome may reflect some of the RF energy transmitted by the linear arrays of radiating elements of a base station antenna. Reflection of transmitted RF energy by a radome decreases the directivity, and hence gain, of the antenna, decreases the front-to-back ratio of the antenna (i.e., the ratio of forwardly directed radiation to rearwardly directed radiation, which preferably should be a large number) and may increase the return loss of the antenna. Moreover, since the impact of the radome is a function of the thickness of the radome along the direction of travel of the RF energy, the radome tends to have a greater impact on RF energy emitted at larger angles from the boresight pointing direction of the linear arrays, as at such angles the RF energy travels through more radome material. Consequently, the radome may also degrade the shapes of the radiation patterns generated by the respective linear arrays of radiating elements included in the antenna. FIGS. 8A and 8B are azimuth radiation patterns that illustrate how the above-described radome effects may impact the radiation pattern of a linear array of radiating elements, with FIG. 8A showing the radiation pattern before the radome is installed and FIG. 8B showing the radiation pattern after the radome is installed. The azimuth pattern shown in FIG. 8A has a suitable shape for a sector antenna. FIG. 8B shows how the addition of a radome may generally degrade the azimuth pattern.

[0031] The degree to which a radome will reflect RF signals tends to increase as the ratio of the thickness of the radome to the wavelength of the RF signal increases. Accordingly, the impact of a radome on the RF signals tends to increase as the thickness of the radome is increased and/or as the wavelength of the RF signal is reduced. As higher frequency RF signals have shorter wavelengths, the introduction of higher frequency bands

for cellular communications service will tend to result in the radome reflecting an increased amount of RF energy.

[0032] Various techniques may be used to reduce or eliminate the above-described "radome effects" that can degrade the performance of a base station antenna. In one such technique, one or more dielectric layers (or structures) may be installed between the radiating elements of a linear array and the front surface of the radome at, for example, a quarter wavelength from the front surface of the radome. These dielectric structure(s) may partially cancel the reflections from the radome, reducing the negative radome effects. However, addition of the dielectric structures increases the cost of the antenna, and the dielectric structures will incur RF losses that reduce the gain of the radiation patterns. Another potential technique is to use radomes that are either thinner or are formed of lower dielectric constant materials (e.g., using PVC as opposed to fiberglass), as such radomes will have reduced impact on the RF signals. However, such changes may reduce the mechanical strength of the radome (and hence the amount of physical protection that the radome provides to the antenna), and/or may increase the cost of manufacturing the radome. As such, changes to the radome may not be a practical solution for many applications.

[0033] Pursuant to embodiments of the present invention, techniques are provided for reducing or eliminating the negative effects that a base station antenna may have on the radiation patterns generated by the linear arrays of radiating elements thereof. According to these techniques, the radiating elements included in linear arrays of radiating elements that would otherwise be impacted by the radome may be positioned so that the radome is within the near field of the radiating elements of these linear arrays. When the radome is in the near field, the radome appears to be part of the antenna structure and the reflections that might otherwise occur can be reduced or avoided altogether.

[0034] For single band base station antennas that only have a single type of radiating element, it may be relatively easy to design the antenna so that the radome is within the near field of the radiating elements, as the radome may be sized so that the front surface thereof is just forward of the radiating elements. However, in multi-band base station antennas, different sized radiating elements are typically used to support service in the different frequency bands, and hence the radome needs to be sized to accommodate the largest of the radiating elements (which typically are the radiating elements for the lowest frequency band). As a result, the radiating elements for the higher frequency bands tend to be farther removed from the radome. This may be problematic, as it is the higher frequency bands that are most susceptible to degradation by the radome, as discussed above.



[0035] Pursuant to some embodiments of the present invention, multi-band base station antennas having stepped backplanes are provided. The radiating elements included in the various arrays included in the antenna may be mounted to extend forwardly from the backplane, and the backplane may serve as both a reflector and as a ground plane for the radiating elements. The stepped backplane may have at least one protruding region that extends farther forwardly than the remainder of the backplane. Radiating elements that operate in a first frequency band may be mounted to extend forwardly from the protruding region of the backplane, while radiating elements that operate in a second, different frequency band may be mounted to extend forwardly from a different portion of the backplane. The protruding portion of the backplane may position the radiating elements that operate in a first frequency band close to the radome so that the radome is within the near field of the first frequency band radiating elements.

[0036] In other embodiments, multi-band base station antennas are provided that have both first and second reflectors. The second reflector may be mounted to extend forwardly from the first reflector, and the radiating elements that operate in a first frequency band are mounted to extend forwardly from the second reflector. Once again, this may position the radiating elements that operate in the first frequency band close to the radome so that the radome is within the near field of the radiating elements. The second reflector may be electrically coupled to the first reflector so that the second reflector will serve as a ground plane for the radiating elements that operate in a first frequency band. In some embodiments, the second reflector may be capacitively coupled to the first reflector in order to reduce or avoid the generation of passive intermodulation distortion that could occur as a result of any metal-on-metal connection between the first reflector and the second reflector.

[0037] In still other embodiments, the radiating elements that operate in the first frequency band may include feed stalks that extend a greater distance above the reflector than usual. As is known in the art, dipole radiators are typically mounted one quarter of a wavelength forwardly of a reflector so that rearwardly emitted RF radiation that reflects off the backplane will generally be in-phase with the forwardly directed radiation. So-called feed stalks are typically used to mount the dipoles a quarter wavelength in front of the reflector and to feed the RF signals to the dipoles. By extending the length of the feed stalks from one-quarter wavelength to three-quarters of a wavelength, the dipoles may be moved closer to the radome and the rearwardly emitted RF radiation that reflects off the reflector will still generally be in-phase with the forwardly directed radiation. Accordingly, pursuant to further embodiments of the present invention the feed stalks for selected radiating elements may be

extended to  $3/4$ ,  $5/4$ ,  $7/4$ , etc. of a wavelength in order to position the radiators of the radiating elements closer to the radome.

[0038] Embodiments of the present invention will now be discussed in greater detail with reference to the attached figures.

[0039] **FIGS. 1-3** illustrate a base station antenna **100** according to certain embodiments of the present invention. In particular, **FIG. 1** is a perspective view of the antenna **100**, while **FIG. 2** is a front view of the antenna **100** with the radome thereof removed to illustrate the antenna assembly **200** of the antenna **100**, and **FIG. 3** is a cross-sectional view of the antenna **100** with the radome in place. **FIG. 4** is a cross-sectional view of a modified version of the antenna **100** that illustrates a conventional technique for mounting the radiating elements thereof.

[0040] In the description that follows, the antenna **100** will be described using terms that assume that the antenna **100** is mounted for normal use on a tower or other structure with the longitudinal axis of the antenna **100** extending along a vertical axis (i.e., generally perpendicular to a plane defined by the horizon) and the front surface of the antenna **100** mounted opposite the tower pointing toward the coverage area for the antenna **100**.

[0041] As shown in **FIG. 1**, the base station antenna **100** is an elongated structure that extends along a longitudinal axis **L**. The base station antenna **100** may have a tubular shape with a generally rectangular cross-section. The antenna **100** includes a radome **110** and a top end cap **120**. In some embodiments, the radome **110** and the top end cap **120** may comprise a single integral unit, which may be helpful for waterproofing the antenna **100**. The radome **110** may serve as a housing that protects internal components of the antenna **100** from precipitation, moisture ingress, wind and the like. Preferably, the radome **110** is relatively rigid and mechanically strong to protect the internal components of the antenna during shipping and installation. One or more mounting brackets **150** are provided on the rear side of the antenna **100** which may be used to mount the antenna **100** onto an antenna mount (not shown) on, for example, an antenna tower. The antenna **100** also includes a bottom end cap **130** which includes a plurality of connectors **140** mounted therein.

[0042] As shown in **FIG. 2**, the antenna **100** includes an antenna assembly **200**. The antenna assembly **200** may be slidably inserted into the radome **110** from either the top or bottom before the top cap **120** or bottom cap **130** are attached to the radome **110**. The antenna assembly **200** includes a backplane **210** that has sidewalls **212** and a planar front surface **214** that acts as a reflector to reflect rearwardly emitted RF radiation in the forward direction. Herein, the front surface of backplane **210** is referred to as the first reflector **214**.

Various mechanical and electronic components of the antenna (not shown in the figures) may be mounted in the chamber defined between the sidewalls **212** and the back side of the reflector surface **214** such as, for example, phase shifters, remote electronic tilt units, mechanical linkages, a controller, duplexers, and the like. The first reflector **214** may comprise or include a metallic surface that serves as a reflector and ground plane for the radiating elements of the antenna **100**.

[0043] A plurality of dual-polarized radiating elements **300, 400, 500** are mounted to extend forwardly from the first reflector **214**. The radiating elements include low-band radiating elements **300**, mid-band radiating elements **400** and high-band radiating elements **500**. The low-band radiating elements **300** are mounted in two columns to form two linear arrays **220-1, 220-2** of low-band radiating elements **300**. The low-band radiating elements **300** may be configured to transmit and receive signals in a first frequency band such as, for example, the 694-960 MHz frequency range or a portion thereof. The mid-band radiating elements **400** may likewise be mounted in two columns to form two linear arrays **230-1, 230-2** of mid-band radiating elements **400**. The mid-band radiating elements **400** may be configured to transmit and receive signals in a second frequency band such as, for example, the 1427-2690 MHz frequency range or a portion thereof. The high-band radiating elements **500** are mounted in four columns to form four linear arrays **240-1** through **240-4** of high-band radiating elements **500**. The high-band radiating elements **500** may be configured to transmit and receive signals in a third frequency band such as, for example, the 3300-4200 MHz frequency range or a portion thereof.

[0044] In the depicted embodiment, the linear arrays **240** of high-band radiating elements **500** are positioned between the linear arrays **220** of low-band radiating elements **300**, and each linear array **220** of low-band radiating elements **300** is positioned between a respective one of the linear arrays **240** of high-band radiating elements **500** and a respective one of the linear arrays **230** of mid-band radiating elements **400**. It will be appreciated that the arrangement of the linear arrays **220, 230, 240** may be varied from what is depicted in **FIG. 2**. Likewise, it will be appreciated that the number of linear arrays **220, 230, 240** may be varied from what is shown in **FIG. 2**, as may the number of radiating elements **300, 400, 500** per linear array **220, 230, 240**, the type of radiating elements used, etc. Additionally, more or less different types of linear arrays may be included. For example, the linear arrays **230** of mid-band radiating elements **400** could be omitted in another example embodiment.

[0045] The low-band, mid-band and high-band radiating elements **300, 400, 500** may each be mounted to extend forwardly from the first reflector **214**. The first reflector **214** may

comprise a sheet of metal that, as noted above, serves as a reflector and as a ground plane for the radiating elements **300, 400, 500**.

[0046] Each low-band, mid-band and high-band radiating element **300, 400, 500** may include a respective feed stalk **310, 410, 510** and one or more radiators **320, 420, 520** (see **FIG. 3**). In the depicted embodiment, each radiating element **300, 400, 500** is implemented as a cross-polarized dipole radiating element having feed stalks **310, 410, 510** that are formed using a pair of printed circuit boards that are configured in an "X" shape and a pair of dipole radiators **320, 420, 520** that are mounted forwardly from the backplane **210** by the feed stalks **310, 410, 510**. For each radiating element **300, 400, 500**, the first dipole radiator may be mounted at an angle of about  $-45^\circ$  with respect to the horizon and the second dipole radiator may be mounted at an angle of about  $+45^\circ$  with respect to the horizon so that each radiating element **300, 400, 500** may emit a first RF signal having a slant  $-45^\circ$  polarization and a second RF signal having a slant  $+45^\circ$  polarization.

[0047] Typically, the radiating elements of a multi-band antenna such as the antenna **100** are all mounted on a common backplane that has a generally planar reflector surface. **FIG. 4** is a cross-sectional view of a modified version of the antenna **100** that illustrates this conventional mounting technique for comparative purposes. As shown in **FIG. 4**, the backplane **210** includes a planar first reflector **214** and a pair of side supports **212**. The radiating elements **300, 400, 500** are all mounted to extend forwardly from the first reflector **214**. The radome **110** may be designed to extend slightly farther forwardly than the low-band radiating elements **300**. Since the high-band radiating elements **500** operate in a much higher frequency band, the feed stalks **510** on the high-band radiating elements **500** may be much shorter than the feed stalks **310** on the low-band radiating elements **300**, and hence the dipole radiators **520** on the high-band radiating elements **500** may be positioned relatively far back from a front surface **112** of the radome **110**.

[0048] As discussed above, a radome may start to reflect RF signals emitted by a radiating element that is mounted behind the radome as the ratio of the thickness of the radome to the wavelength of the RF signal increases. Various other factors, including the dielectric constant of the radome material and the distance separating the radiating element from the radome also impact the degree of reflection. It has been found that when low-band radiating elements **300** that operate in the 694-960 MHz frequency band and high-band radiating elements **500** that operate in the 3300-4200 MHz are mounted in the fashion shown in **FIG. 4** behind a conventional fiberglass radome, the radiation patterns of the high-band

radiating elements **500** are significantly distorted and significant reflections result in degradation of the antenna's front-to-back ratio and directivity (gain).

[0049] **FIG. 3** is a cross-sectional view of the base station antenna **100** that illustrates a modified design that may significantly reduce or even eliminate the distortion that the radome **110** may have on the radiation patterns of the high-band radiating elements **500** pursuant to embodiments of the present invention. As shown in **FIG. 3**, a second reflector **250** is mounted to extend forwardly from a central portion of the first reflector **214**. The second reflector **250** may comprise, for example, a piece of sheet metal that is bent to have the cross-section shown in **FIG. 3**. The second reflector **250** may have a front surface **252**, sidewalls **254** and rear lips **256** which may extend either inwardly (as shown) or outwardly. The lips **256** may be used to mount the second reflector **250** to extend forwardly from the first reflector **214**. Dielectric sheet material **258** may be interposed between the first reflector **214** and each lip **256** of the second reflector **250**. Plastic screws or rivets **260** may be inserted through openings in the lips **256** and the first reflector **214** to secure the second reflector **250** to the first reflector **214**. The use of plastic fasteners **260** along with the dielectric sheet material **258** interposed between the backplane **210** and each lip **256** of the second reflector **250** may advantageously avoid metal-to-metal contact between the first reflector **214** and the second reflector **250** that could give rise to passive intermodulation distortion. The second reflector **250** may be capacitively coupled to the first reflector **214** through the dielectric sheet material **258** to provide a ground reference to the second reflector **250**.

[0050] As shown in **FIG. 3**, the high-band radiating elements **500** are mounted to extend forwardly from the second reflector **250**. The sidewalls **254** of the second reflector **250** may be dimensioned so that the distance between the first reflector **214** and the front surface **252** of the second reflector **250** may be selected so that the radiators **520** of the high-band radiating elements **500** may be located in close proximity to the front surface **112** of the radome **110**. The radome **110** may thus be in the near field of the radiating elements **500**. When positioned in the near field, the radome **110** may appear to be part of the radiating element **500** and reflection of RF energy emitted by the radiating element **500** may be reduced or even largely eliminated.

[0051] It has been found that mounting the second reflector **250** to extend forwardly from the first reflector **214** may not only reduce the radome effect, but may also improve other performance aspects of the base station antenna **100**. For example, in an antenna such as base station antenna **100** that includes eight linear arrays of radiating elements, it is typically necessary to space the linear arrays in very close proximity to one another. This

may result in coupling between different ones of the linear arrays that may degrade the radiation patterns. In the base station antenna **100**, such coupling is of particular concern with respect to the linear arrays **220-1** and **220-2** (i.e., the two linear arrays of low-band radiating elements). It has been found that the inclusion of the second reflector **250**, as well as the fact that the radiating elements **500** are mounted farther forwardly, tends to act as an RF shield structure that reduces coupling between linear arrays **220-1** and **220-2**, and thus the inclusion of the second reflector **250** may actually improve the radiation patterns of linear arrays **220-1**, **220-2**.

[0052] **FIG. 5** is a schematic diagram illustrating a backplane **610** that may be used in place of the backplane **210** and second reflector **250** illustrated in **FIG. 3**. As shown in **FIG. 5**, the backplane **610** includes side supports **612** and a stepped reflector **614**. The stepped reflector **614** may include low-band steps **620** that serve as mounting surfaces for the low-band radiating elements **300**, mid-band steps **622** that serve as mounting surfaces for the mid-band radiating elements **400**, and a high-band step **624** that serves as a mounting surface for the high-band radiating elements **500**. The low-band steps **620** may be the farthest from the front surface **112** of the radome **110**, the high-band steps **624** may be the closest to the front surface **112** of the radome **110**, and the mid-band steps **622** may be at an intermediate position between the low-band steps **622** and the high-band steps **624**. The steps **620**, **622**, **624** may be connected by sidewalls **626**. The backplane **610** may be formed by bending a unitary piece of sheet metal, and may be used to advantageously position the radiators of all of the radiating elements **300**, **400**, **500** in close proximity to the front surface **112** of the radome **110**.

[0053] It will be appreciated that the backplane **610** having the stepped reflector **614** of **FIG. 5** represents one example backplane design, and that the same concept may be used to provide stepped reflectors for a wide variety of different base station antennas. The number and locations of the stepped surfaces may depend, for example, on the different types and locations of the linear arrays of radiating elements included in a particular base station antenna as well as the extent to which the radiating elements are impacted by the radome. By way of example, **FIGS. 6A** and **6B** illustrate two additional backplanes that have stepped reflectors. Referring first to **FIG. 6A**, a backplane **710** is illustrated that has a stepped reflector **714** that has a low-band step **720** that serves as a mounting surface for a linear array of low-band radiating elements (not shown) and a high-band step **724** that serves as a mounting surface for a linear array of high-band radiating elements (not shown). **FIG. 6B** schematically illustrates a backplane **810** that has a stepped reflector **814** that has a pair of

low-band steps **820** that serve as mounting surfaces for a respective pair of linear arrays of low-band radiating elements (not shown) and a high-band step **824** that serves as a mounting surface for one or more linear arrays of high-band radiating elements (not shown).

[0054] Pursuant to further embodiments of the present invention, the radiators of the high-band radiating elements may be positioned in close proximity to the front surface **112** of the radome **110** by designing the high-band radiating elements to have extended feed stalks. A high-band radiating element **900** having such a design is schematically shown in **FIG. 7**. The high-band radiating element **900** is designed to operate in two separate frequency bands, namely the 3.3-4.2 GHz and 5.1-5.3 GHz frequency bands.

[0055] As shown in **FIG. 7**, the radiating element **900** is a cross-polarized radiating element having a feed stalk **910** that is implemented as a pair of printed circuit boards **912** that are arranged in an "X" configuration, a pair of dipole radiators **920**, and a pair of dipole radiators **930**. The dipole radiators **920** are configured to operate in, for example, the 3.3-3.8 GHz frequency band, and are directly driven by feed lines included in the respective printed circuit boards **912**. The two dipole radiators **920** are arranged orthogonally to each other at angles of  $-45^\circ$  and  $+45^\circ$  with respect to the longitudinal (vertical) axis of the antenna so that the dipole radiators will emit RF signals having slant  $-45^\circ$  and slant  $+45^\circ$  polarizations, respectively.

[0056] The dipole radiators **930** are configured to operate in, for example, the 5.1-5.3 GHz frequency band. The dipole radiators **930** are located forwardly of the dipole radiators **920**. When a 3.5 GHz signal is input to the radiating element **900**, it is fed directly to one of the dipole radiators **920**. When a 5.1 GHz signal is input to the radiating element **900**, the energy electromagnetically couples to one of the 5.1 GHz parasitic dipole radiators **930**, which then resonates at 5.1 GHz. The two dipole radiators **930** are also arranged orthogonally to each other at angles of  $-45^\circ$  and  $+45^\circ$  with respect to the longitudinal (vertical) axis of the antenna so that the dipole radiators **930** will emit RF signals having slant  $-45^\circ$  and slant  $+45^\circ$  polarizations, respectively.

[0057] The feed stalks **910** may have a height so that the dipole radiators **920** are mounted forwardly of a reflector at a distance of about  $\frac{3}{4}$  of a wavelength of the center frequency of the operating frequency band of the dipole radiators **920**. This approach acts to mount the dipole radiators **920** further from an underlying reflector, and hence closer to the front surface **112** of the radome **110**. As described above, if the dipole radiators **920**, **930** are mounted so that the radome **110** is in the near field of the dipole radiators **920**, **930**, then the radome may appear as part of the radiating element **900**, which will reduce or eliminate any

tendency for the radome **110** to reflect RF energy that is transmitted by the radiating element **900**. While in the embodiment of **FIG. 7**, the dipole radiators **920, 930** are mounted at a distance of about  $\frac{3}{4}$  of a wavelength ( $\lambda$ ) in front of the reflector, it will be appreciated that in other embodiments the dipole radiators **920, 930** could be mounted at a distance of  $M*\lambda/4$ , where  $M$  is an odd integer greater than 1. In still other embodiments, the distance may be greater than  $\lambda/2$ .

**[0058]** The printed circuit boards **912** that are used to implement the feed stalks **910** may include shielded RF transmission lines that are used to pass RF signals between the dipole radiators **920** and other components of an antenna that includes the radiating elements **900**. Thus, it will be understood that the printed circuit boards **912** may comprise stripline printed circuit boards or may use coplanar waveguide transmission lines or other shielded transmission line structures.

**[0059]** While the example embodiments of the present invention have focused primarily on modification to the backplane and/or radiating element design for radiating elements that operate in some or all of the 3.3-4.2 GHz frequency range, it will be appreciated that the techniques disclosed herein may be used with any appropriate frequency band. For example, in other embodiments, the techniques disclosed herein may be used to improve the performance of linear arrays of radiating elements that operate in the 1.7-2.7 GHz frequency band or portions thereof.

**[0060]** Embodiments of the present invention have been described above with reference to the accompanying drawings, in which embodiments of the invention are shown. This invention may, however, be embodied in many different forms and should not be construed as limited to the embodiments set forth herein. Rather, these embodiments are provided so that this disclosure will be thorough and complete, and will fully convey the scope of the invention to those skilled in the art. Like numbers refer to like elements throughout.

**[0061]** In the description above, like elements are referred to individually by their full reference numeral (e.g., linear array **230-2**) and are referred to collectively by the first part of their reference numeral (e.g., the linear arrays **230**).

**[0062]** In the discussion above, reference is made to the linear arrays of radiating elements that are commonly included in base station antennas. It will be appreciated that herein the term "linear array" is used broadly to encompass both arrays of radiating elements that include a single column of radiating elements that are configured to transmit the sub-components of an RF signal as well as to two-dimensional arrays of radiating elements (i.e.,



multiple linear arrays) that are configured to transmit the sub-components of an RF signal. It will also be appreciated that in some cases the radiating elements may not be disposed along a single line. For example, in some cases a linear array of radiating elements may include one or more radiating elements that are offset from a line along which the remainder of the radiating elements are aligned. This "staggering" of the radiating elements may be done to design the array to have a desired azimuth beamwidth. Such staggered arrays of radiating elements that are configured to transmit the sub-components of an RF signal are encompassed by the term "linear array" as used herein.

[0063] It will be understood that, although the terms first, second, etc. may be used herein to describe various elements, these elements should not be limited by these terms. These terms are only used to distinguish one element from another. For example, a first element could be termed a second element, and, similarly, a second element could be termed a first element, without departing from the scope of the present invention. As used herein, the term "and/or" includes any and all combinations of one or more of the associated listed items.

[0064] It will be understood that when an element is referred to as being "on" another element, it can be directly on the other element or intervening elements may also be present. In contrast, when an element is referred to as being "directly on" another element, there are no intervening elements present. It will also be understood that when an element is referred to as being "connected" or "coupled" to another element, it can be directly connected or coupled to the other element or intervening elements may be present. In contrast, when an element is referred to as being "directly connected" or "directly coupled" to another element, there are no intervening elements present. Other words used to describe the relationship between elements should be interpreted in a like fashion (*i.e.*, "between" versus "directly between", "adjacent" versus "directly adjacent", etc.).

[0065] Relative terms such as "below" or "above" or "upper" or "lower" or "horizontal" or "vertical" may be used herein to describe a relationship of one element, layer or region to another element, layer or region as illustrated in the figures. It will be understood that these terms are intended to encompass different orientations of the device in addition to the orientation depicted in the figures.

[0066] The terminology used herein is for the purpose of describing particular embodiments only and is not intended to be limiting of the invention. As used herein, the singular forms "a", "an" and "the" are intended to include the plural forms as well, unless the context clearly indicates otherwise. It will be further understood that the terms "comprises"

"comprising," "includes" and/or "including" when used herein, specify the presence of stated features, operations, elements, and/or components, but do not preclude the presence or addition of one or more other features, operations, elements, components, and/or groups thereof.

[0067] Aspects and elements of all of the embodiments disclosed above can be combined in any way and/or combination with aspects or elements of other embodiments to provide a plurality of additional embodiments.

That Which is Claimed is:

1. A base station antenna, comprising:  
a radome; and  
an antenna assembly that is mounted within the radome, the antenna assembly including:  
a backplane that includes a first reflector;  
a first array that includes a plurality of first radiating elements that are mounted to extend forwardly from the first reflector;  
a second reflector mounted to extend forwardly from the first reflector; and  
a second array that includes a plurality of second radiating elements that are mounted to extend forwardly from the second reflector,  
wherein the first radiating elements extend a first distance forwardly from the first reflector and the second radiating elements extend a second distance forwardly from the second reflector, where the first distance exceeds the second distance.
2. The base station antenna of Claim 1, wherein the second reflector is electrically connected to the first reflector.
3. The base station antenna of Claim 2, wherein the second reflector is capacitively coupled to the first reflector.
4. The base station antenna of any of Claims 1-3, wherein the first radiating elements are mounted to extend forwardly from a first planar surface of the first reflector and the second radiating elements are mounted to extend forwardly from a second planar surface of the second reflector.
5. The base station antenna of Claim 4, wherein the first planar surface extends in parallel to the second planar surface.
6. The base station antenna of any of Claims 4 or 5, wherein the second reflector includes a pair of lips that extend in parallel to the second planar surface.
7. The base station antenna of any of Claims 1-6, wherein each second radiating element includes at least one radiator, and wherein the second radiating elements are mounted

so that a front surface of the radome is within a near field of the radiators of the second radiating elements.

8. A base station antenna, comprising:  
a radome; and  
an antenna assembly that is mounted within the radome, the antenna assembly including:  
a backplane that includes a stepped reflector that has at least a first front surface, a second front surface, and a sidewall disposed between the first front surface and the second front surface;  
a first array that includes a plurality of first radiating elements that are mounted to extend forwardly from the first front surface; and  
a second array that includes a plurality of second radiating elements that are mounted to extend forwardly from the second front surface.

9. The base station antenna of Claim 8, wherein the first front surface is parallel to the second front surface.

10. The base station antenna of Claim 8 or 9, wherein the second front surface is closer to a front surface of the radome than is the first front surface.

11. The base station antenna of any of Claims 8-10, wherein the first radiating elements are configured to operate in a first frequency band and the second radiating elements are configured to operate in a second frequency band that is higher in frequency than the first frequency band.

12. The base station antenna of any of Claims 8-11, wherein each second radiating element includes at least one radiator, and wherein the second radiating elements are mounted so that a front surface of the radome is within a near field of the radiators of the second radiating elements.

13. The base station antenna of any of Claims 8-12, wherein the stepped reflector further includes a third front surface that is parallel to the second front surface and spaced apart from both the first front surface and the second front surface, the base station antenna further comprising a third array that includes a plurality of third radiating elements that are mounted to extend forwardly from the third front surface.

14. The base station antenna of any of Claims 8-13, wherein the stepped reflector is a monolithic structure.

15. A base station antenna, comprising:  
a radome; and  
a backplane mounted within the radome;  
a linear array of radiating elements mounted to extend forwardly from the backplane, each radiating element includes a feed stalk and a dipole radiator,  
wherein each radiator is mounted at a distance of approximately  $M*\lambda/4$  forwardly of the backplane, where  $M$  is an odd integer greater than 1 and  $\lambda$  is a wavelength corresponding to a center frequency of an operating frequency band of the dipole radiators.

16. The base station antenna of Claim 15, wherein each feed stalk comprises a printed circuit board having a shielded transmission line thereon.

17. The base station antenna of Claim 16, wherein the shielded transmission line comprises a stripline transmission line.

18. The base station antenna of Claim 16, wherein the shielded transmission line comprises a coplanar waveguide transmission line.

19. The base station antenna of any of Claims 15-18, wherein the radiating elements are mounted so that a front surface of the radome is within a near field of the dipole radiators of the radiating elements.

20. The base station antenna of any of Claims 15-19, wherein  $M = 3$ .

21. The base station antenna of any of Claims 15-20, wherein the linear array is a first linear array of first radiating elements, further comprising a second linear array of second radiating elements that are configured to operate in a second frequency band, wherein dipole radiators of the second radiating elements are mounted less than half a wavelength of a center frequency of the second operating frequency band forwardly from the backplane.

22. The base station antenna of any of Claims 1-7, further comprising a third array that includes a plurality of third radiating elements that are mounted to extend forwardly from the first reflector, the first and third radiating elements configured to operate in a first

frequency band and the second radiating elements configured to operate in a second, higher, frequency band.

23. The base station antenna Claim 22, wherein the second array is positioned between the first array and the third array.

24. A base station antenna, comprising:  
a radome; and  
a reflector mounted within the radome;  
a linear array of radiating elements mounted to extend forwardly from the reflector,  
each radiating element includes a feed stalk and a dipole radiator,  
wherein each feed stalk has a length that is greater than  $\lambda/2$ , where  $\lambda$  is a wavelength corresponding to a center frequency of an operating frequency band of the dipole radiators.

25. The base station antenna Claim 24, wherein each feed stalk comprises a printed circuit board having a shielded transmission line thereon.

26. The base station antenna Claim 25, wherein the shielded transmission line comprises a stripline transmission line.

27. The base station antenna Claim 25, wherein the shielded transmission line comprises a coplanar waveguide transmission line.

28. The base station antenna Claim 15, wherein the radiating elements are mounted so that a front surface of the radome is within a near field of the dipole radiators of the radiating elements.

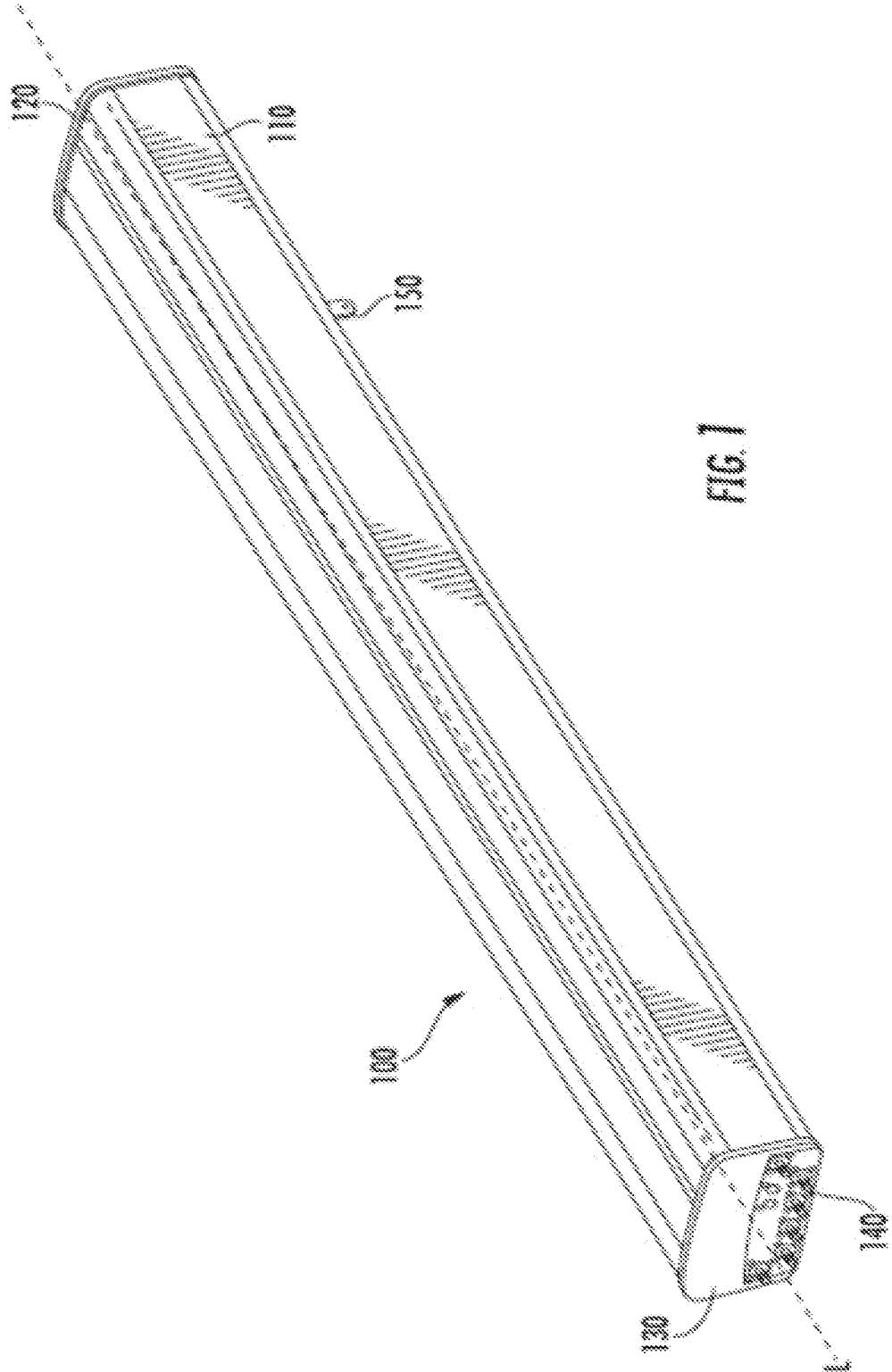
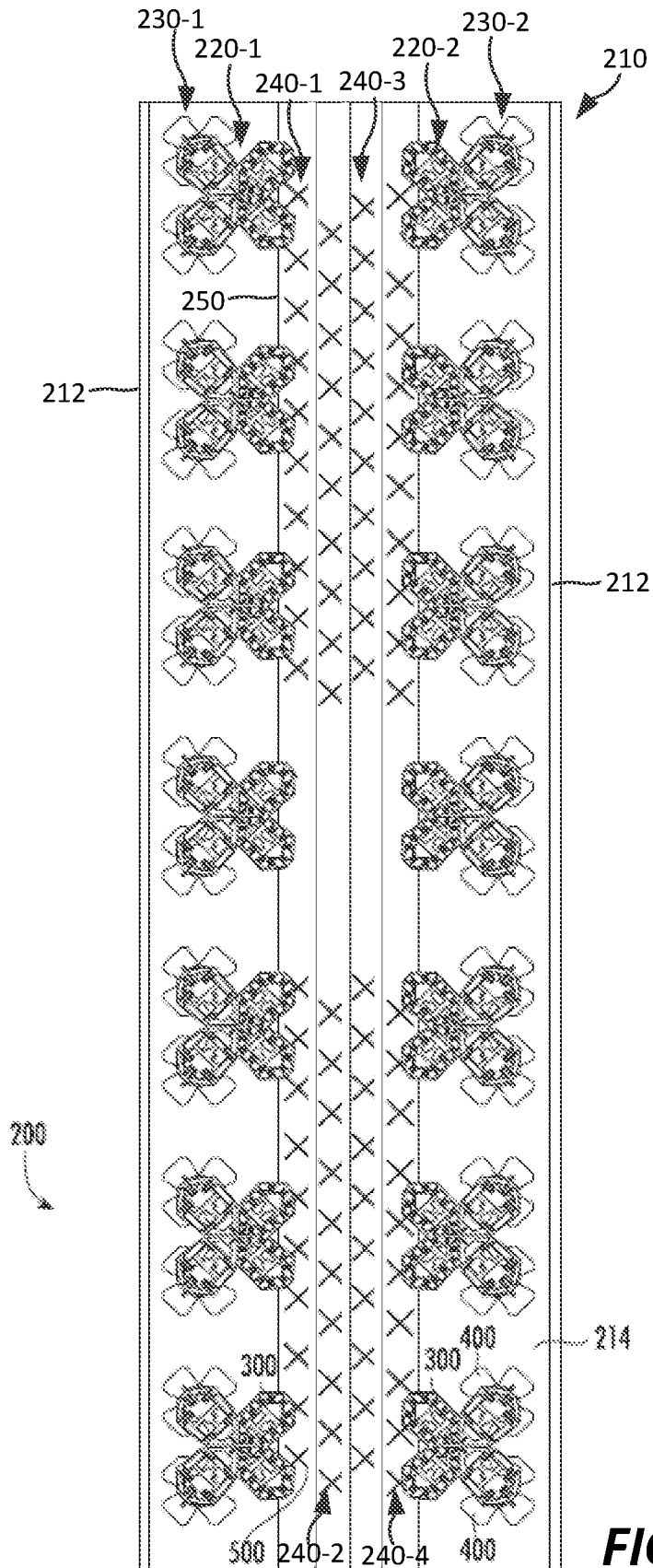
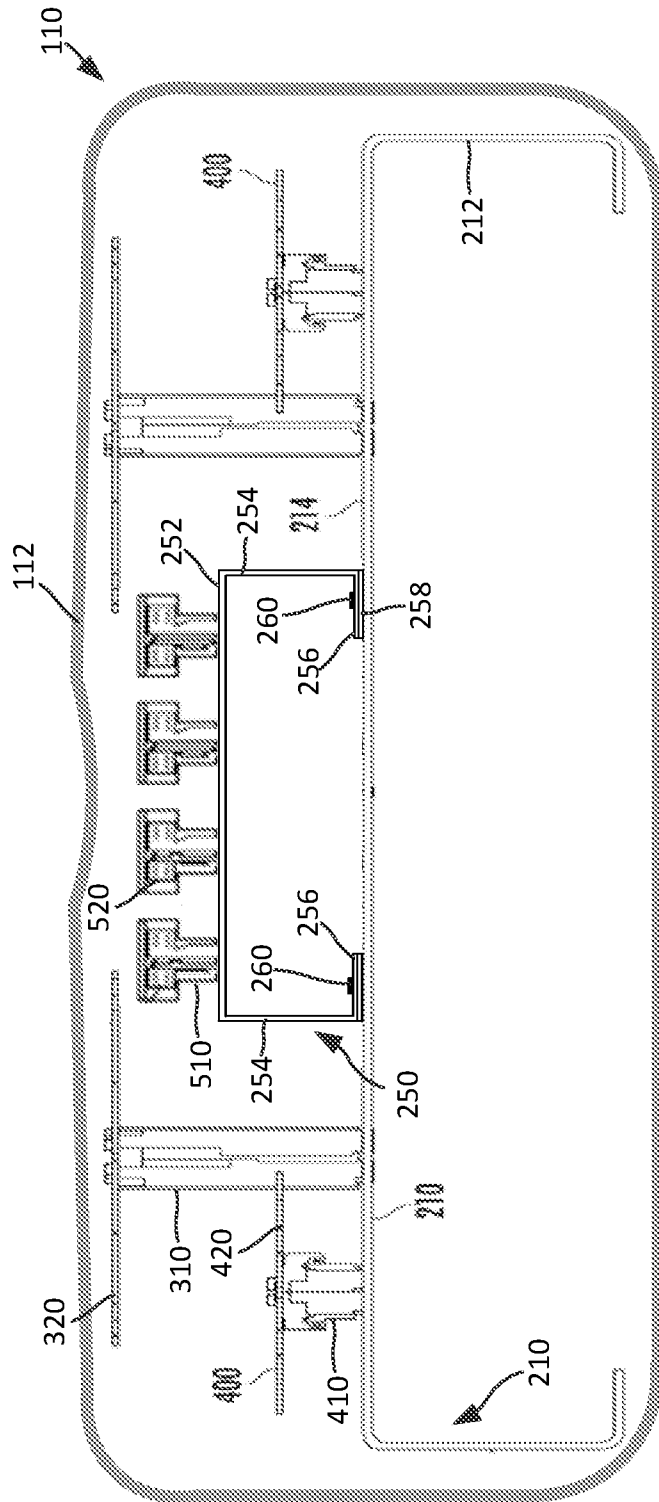

FIG. 1

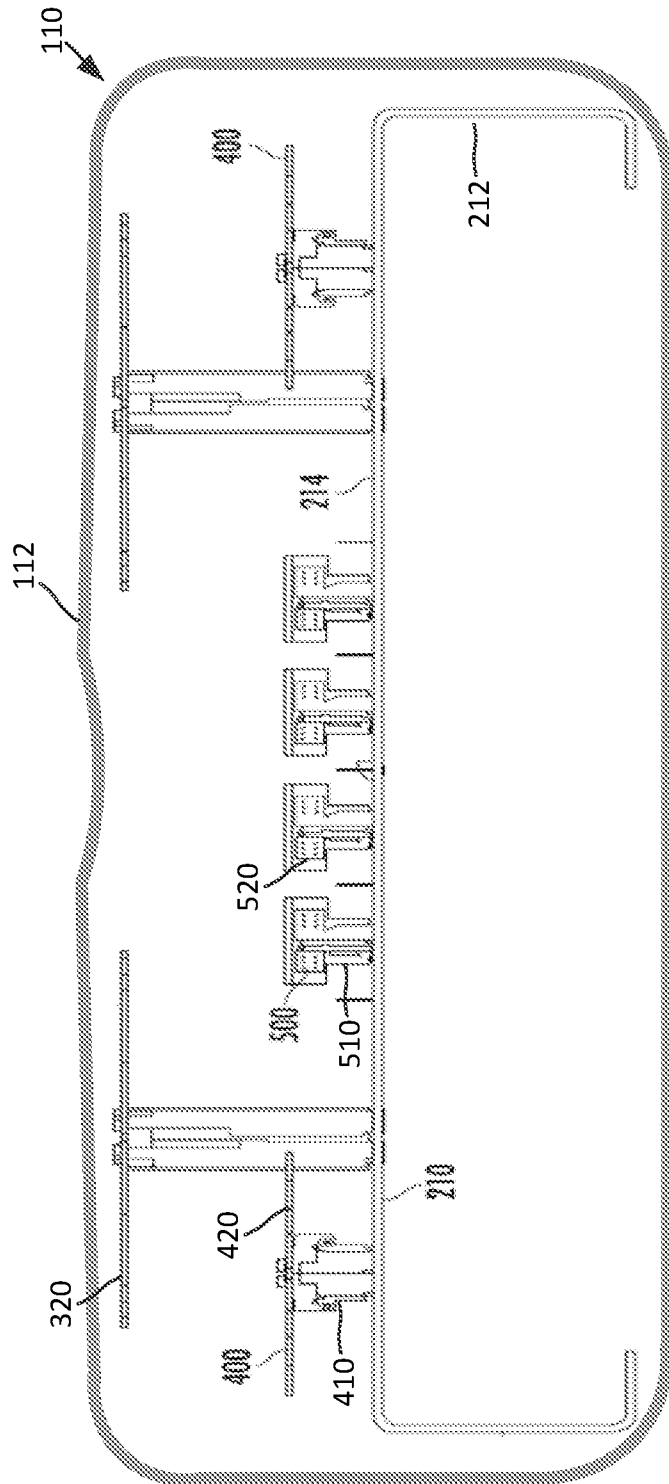

**FIG. 2**

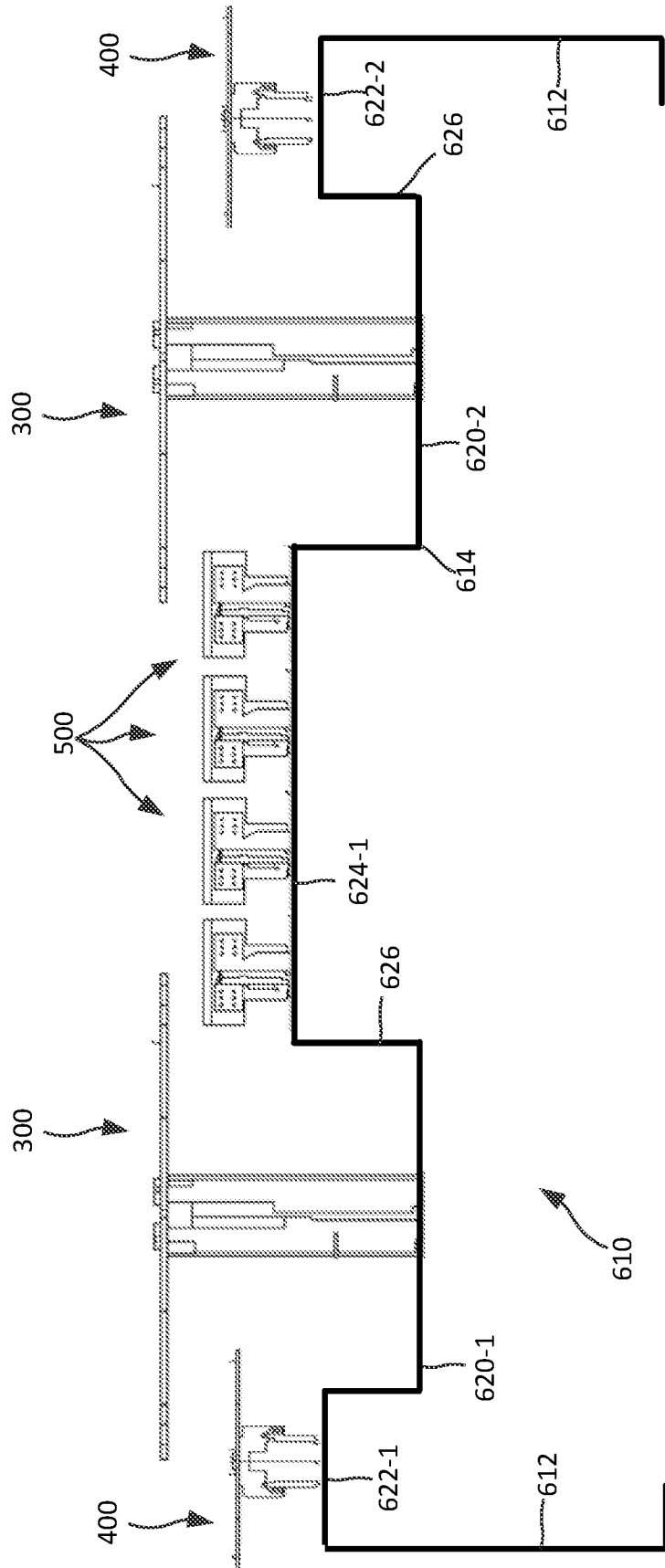



**FIG. 3**



**FIG. 4**



**FIG. 5**

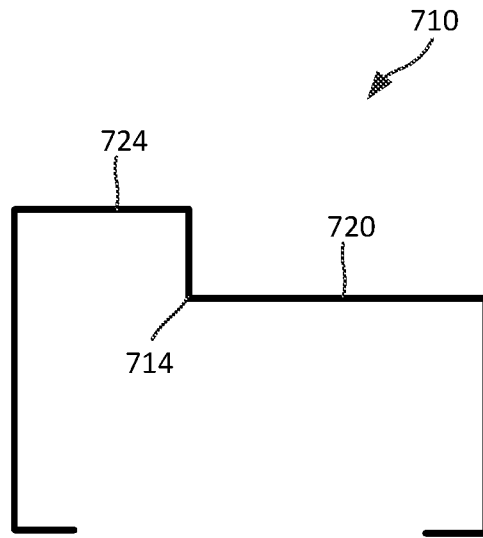

**FIG. 6A**

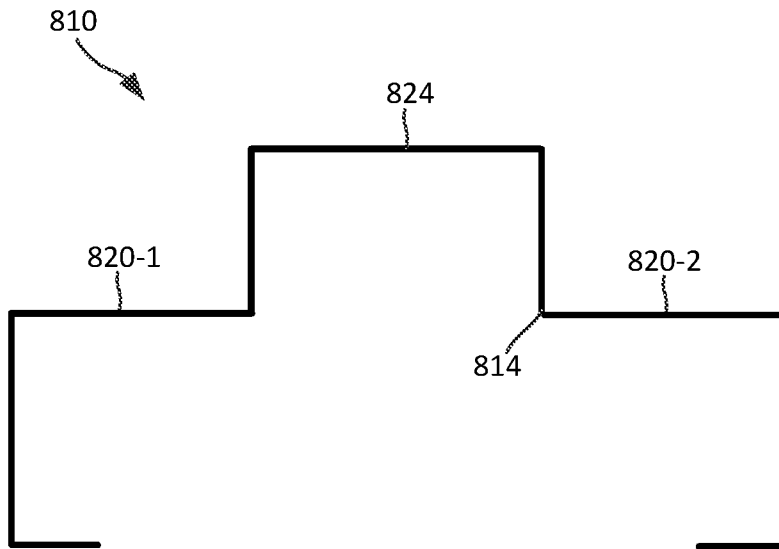

**FIG. 6B**

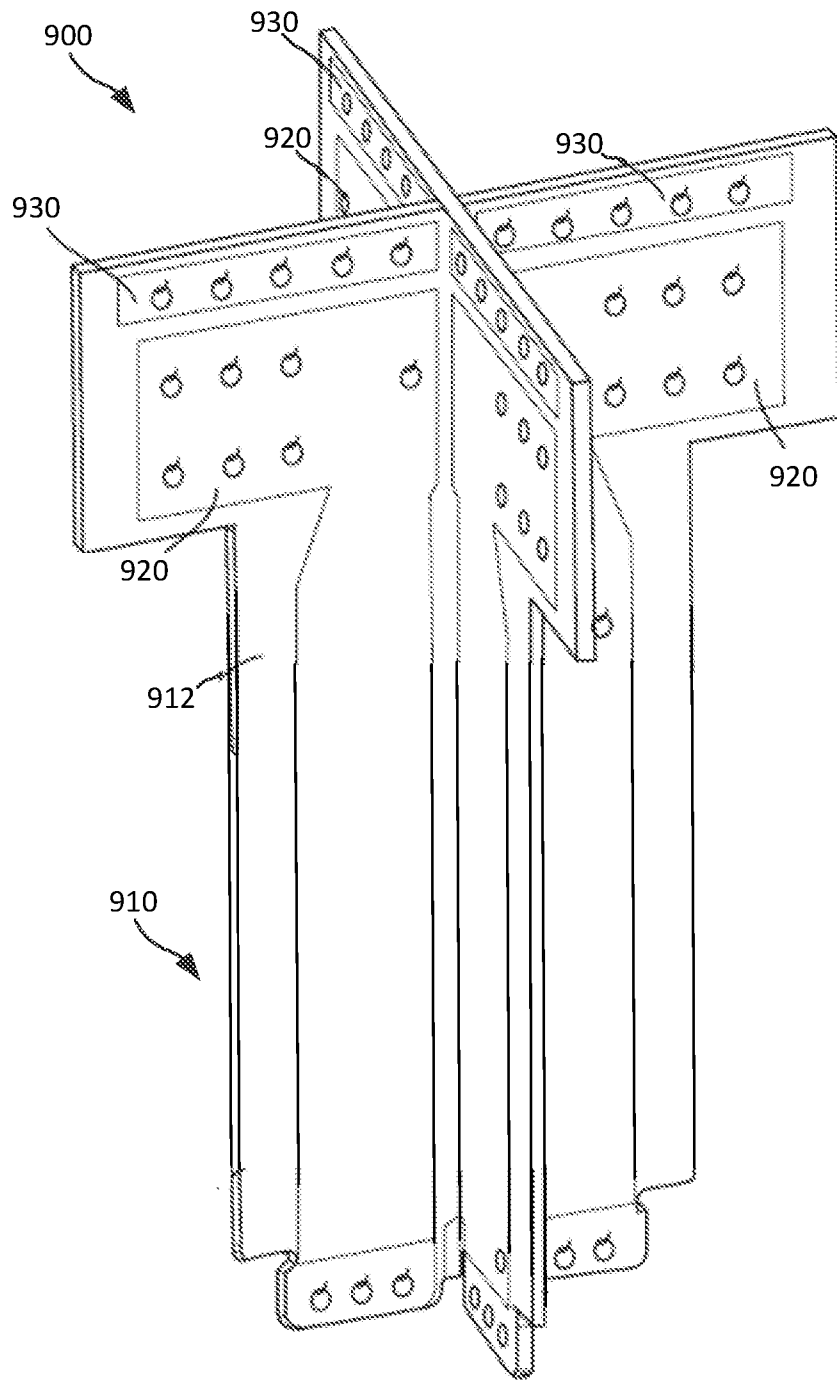

**FIG. 7**

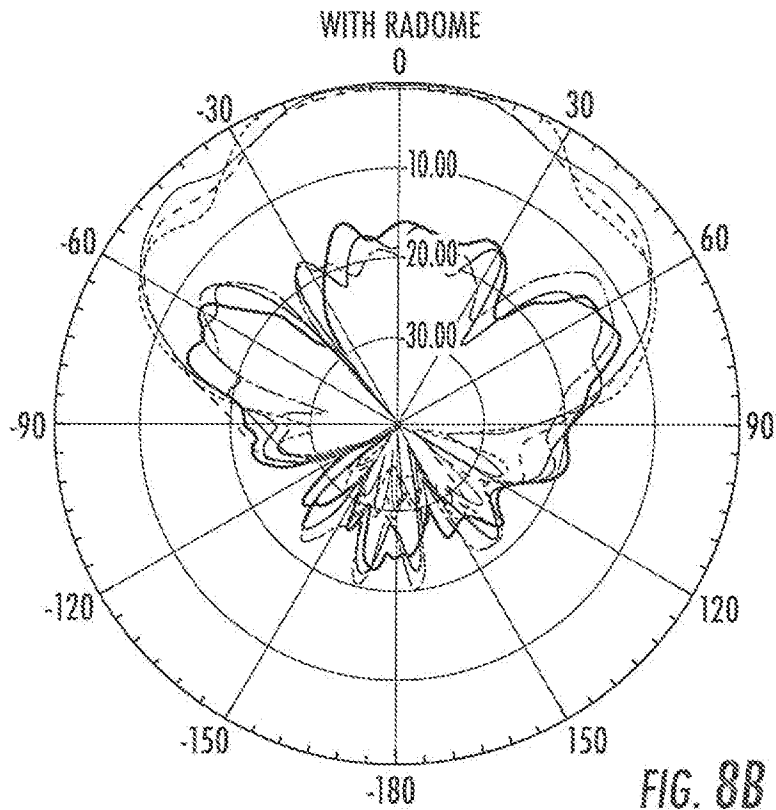
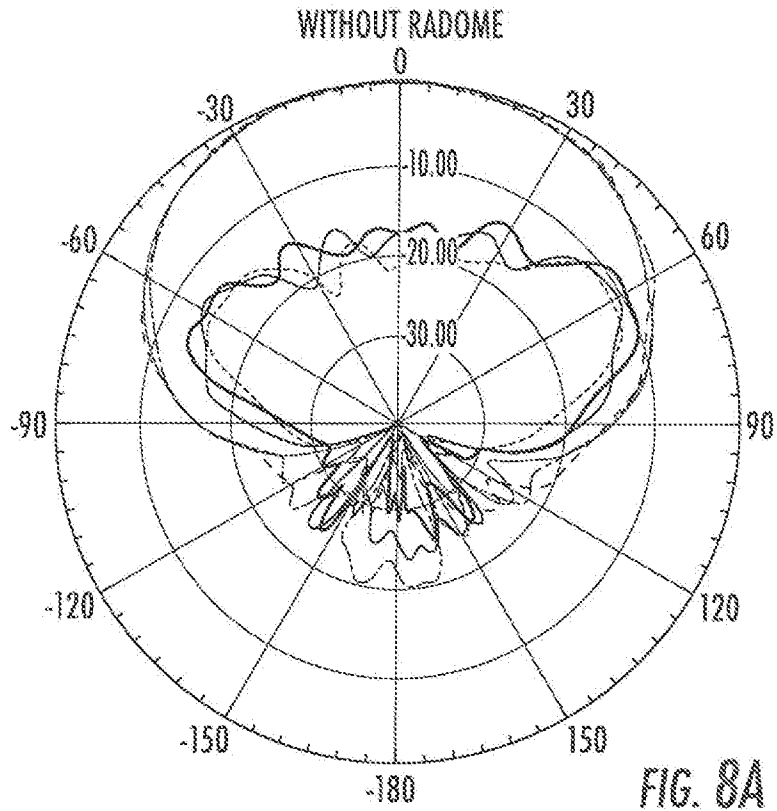

## INTERNATIONAL SEARCH REPORT

International application No.

PCT/US2019/040227

**Box No. II Observations where certain claims were found unsearchable (Continuation of item 2 of first sheet)**

This international search report has not been established in respect of certain claims under Article 17(2)(a) for the following reasons:

1.  Claims Nos.:  
because they relate to subject matter not required to be searched by this Authority, namely:
  
2.  Claims Nos.:  
because they relate to parts of the international application that do not comply with the prescribed requirements to such an extent that no meaningful international search can be carried out, specifically:
  
3.  Claims Nos.: 6, 7, 11-14, 20-23  
because they are dependent claims and are not drafted in accordance with the second and third sentences of Rule 6.4(a).

**Box No. III Observations where unity of invention is lacking (Continuation of item 3 of first sheet)**

This International Searching Authority found multiple inventions in this international application, as follows:

See extra sheet(s).

1.  As all required additional search fees were timely paid by the applicant, this international search report covers all searchable claims.
2.  As all searchable claims could be searched without effort justifying additional fees, this Authority did not invite payment of additional fees.
3.  As only some of the required additional search fees were timely paid by the applicant, this international search report covers only those claims for which fees were paid, specifically claims Nos.:
  
4.  No required additional search fees were timely paid by the applicant. Consequently, this international search report is restricted to the invention first mentioned in the claims; it is covered by claims Nos.:  
1-5, 8-10

**Remark on Protest**

- The additional search fees were accompanied by the applicant's protest and, where applicable, the payment of a protest fee.
- The additional search fees were accompanied by the applicant's protest but the applicable protest fee was not paid within the time limit specified in the invitation.
- No protest accompanied the payment of additional search fees.

## INTERNATIONAL SEARCH REPORT

International application No.

PCT/US2019/040227

## A. CLASSIFICATION OF SUBJECT MATTER

IPC(8) - H01Q 21/00; H01Q 19/00; H01Q 1/12; H01Q 1/42 (2019.01)

CPC - H01Q 1/246; H01Q 19/10; H01Q 21/06; H01Q 25/00 (2019.08)

According to International Patent Classification (IPC) or to both national classification and IPC

## B. FIELDS SEARCHED

Minimum documentation searched (classification system followed by classification symbols)

See Search History document

Documentation searched other than minimum documentation to the extent that such documents are included in the fields searched

USPC - 343/853; 343/836; 343/872 (keyword delimited)

Electronic data base consulted during the international search (name of data base and, where practicable, search terms used)

See Search History document

## C. DOCUMENTS CONSIDERED TO BE RELEVANT

Category*	Citation of document, with indication, where appropriate, of the relevant passages	Relevant to claim No.
Y --- A	US 2010/0265150 A1 (ARVIDSSON et al) 21 October 2010 (21.10.2010) <i>entire document</i>	8-10 --- 1-5
Y A	WO 2007/002235 A2 (LOCKHEED MARTIN CORPORATION) 04 January 2007 (04.01.2007) <i>entire document</i>	8-10 1-5
A	US 2005/0046514 A1 (JANOSCHKA) 03 March 2005 (03.03.2005) <i>entire document</i>	1-5
A	US 2007/0241979 A1 (YANG) 18 October 2007 (18.10.2007) <i>entire document</i>	1-5
A	US 2006/0176235 A1 (GOTTL et al) 10 August 2006 (10.08.2006) <i>entire document</i>	1-5, 8-10
A	US 2009/0305710 A1 (JOHNSON et al) 10 December 2009 (10.12.2009) <i>entire document</i>	1-5, 8-10
A	US 2006/0192719 A1 (KONG et al) 31 August 2006 (31.08.2006) <i>entire document</i>	1-5, 8-10
A	US 2015/0280328 A1 (SANFORD et al) 01 October 2015 (01.10.2015) <i>entire document</i>	1-5, 8-10

 Further documents are listed in the continuation of Box C. See patent family annex.

## \* Special categories of cited documents:

"A" document defining the general state of the art which is not considered to be of particular relevance

"E" earlier application or patent but published on or after the international filing date

"L" document which may throw doubts on priority claim(s) or which is cited to establish the publication date of another citation or other special reason (as specified)

"O" document referring to an oral disclosure, use, exhibition or other means

"P" document published prior to the international filing date but later than the priority date claimed

"T" later document published after the international filing date or priority date and not in conflict with the application but cited to understand the principle or theory underlying the invention

"X" document of particular relevance; the claimed invention cannot be considered novel or cannot be considered to involve an inventive step when the document is taken alone

"Y" document of particular relevance; the claimed invention cannot be considered to involve an inventive step when the document is combined with one or more other such documents, such combination being obvious to a person skilled in the art

"&amp;" document member of the same patent family

Date of the actual completion of the international search

15 October 2019

Date of mailing of the international search report

25 OCT 2019

Name and mailing address of the ISA/US

Mail Stop PCT, Attn: ISA/US, Commissioner for Patents  
P.O. Box 1450, Alexandria, VA 22313-1450

Facsimile No. 571-273-8300

Authorized officer

Blaine R. Copenheaver

PCT Helpdesk: 571-272-4300

PCT OSP: 571-272-7774



INTERNATIONAL SEARCH REPORT

International application No.

PCT/US2019/040227

Continued from Box No. III Observations where unity of invention is lacking

This application contains the following inventions or groups of inventions which are not so linked as to form a single general inventive concept under PCT Rule 13.1. In order for all inventions to be examined, the appropriate additional examination fees must be paid.

Group I, claims 1-5 and 8-10, are drawn to a base station antenna, comprising: a radome; and an antenna assembly that is mounted within the radome, the antenna assembly including: a backplane that includes a first reflector.

Group II, claims 15-19 and 24-28, are drawn to a base station antenna, comprising: a radome; and a backplane mounted within the radome; a linear array of radiating elements mounted to extend forwardly from the backplane, each radiating element includes a feed stalk and a dipole radiator.

The inventions listed as Groups I-II do not relate to a single general inventive concept under PCT Rule 13.1 because, under PCT Rule 13.2, they lack the same or corresponding special technical features for the following reasons: the special technical feature of the Group I invention: an antenna assembly that is mounted within the radome, the antenna assembly including: a backplane that includes a first reflector; a first array that includes a plurality of first radiating elements that are mounted to extend forwardly from the first reflector; a second reflector mounted to extend forwardly from the first reflector; and a second array that includes a plurality of second radiating elements that are mounted to extend forwardly from the second reflector, wherein the first radiating elements extend a first distance forwardly from the first reflector and the second radiating elements extend a second distance forwardly from the second reflector, where the first distance exceeds the second distance as claimed therein is not present in the invention of Group II. The special technical feature of the Group II invention: a linear array of radiating elements mounted to extend forwardly from the backplane, each radiating element includes a feed stalk and a dipole radiator, wherein each radiator is mounted at a distance of approximately  $M \cdot \lambda / 4$  forwardly of the backplane, where M is an odd integer greater than 1 and  $\lambda$  is a wavelength corresponding to a center frequency of an operating frequency band of the dipole radiators as claimed therein is not present in the invention of Group I.

Groups I and II lack unity of invention because even though the inventions of these groups require the technical feature of a base station antenna, comprising: a radome; a backplane mounted within the radome; and a linear array of radiating elements, this technical feature is not a special technical feature as it does not make a contribution over the prior art.

Specifically, US 2005/0046514 to Janoschka teaches a base station antenna, comprising: a radome; a backplane mounted within the radome; and a linear array of radiating elements (Paras. [0057-0058], [0067-0068]).

Since none of the special technical features of the Group I or II inventions are found in more than one of the inventions, unity of invention is lacking.