



- (51) International Patent Classification:
G06Q 50/04 (2012.01)
- (21) International Application Number:
PCT/US2014/054042
- (22) International Filing Date:
4 September 2014 (04.09.2014)
- (25) Filing Language: English
- (26) Publication Language: English
- (30) Priority Data:
61/873,610 4 September 2013 (04.09.2013) US
- (71) Applicant: ADC TELECOMMUNICATIONS, INC.
[US/US]; 501 Shenandoah Drive, Shakopee, Minnesota 55379 (US).
- (72) Inventor; and
(71) Applicant : THOMPSON, Pat [US/US]; 3162 Butternut Circle, Prior Lake, Minnesota 55372 (US).
- (74) Agent: POWERS, Jon; Fogg & Powers LLC, 4600 W 77th St, Suite 305, Minneapolis, Minnesota 55435 (US).

- (81) Designated States (unless otherwise indicated, for every kind of national protection available): AE, AG, AL, AM, AO, AT, AU, AZ, BA, BB, BG, BH, BN, BR, BW, BY, BZ, CA, CH, CL, CN, CO, CR, CU, CZ, DE, DK, DM, DO, DZ, EC, EE, EG, ES, FI, GB, GD, GE, GH, GM, GT, HN, HR, HU, ID, IL, IN, IR, IS, JP, KE, KG, KN, KP, KR, KZ, LA, LC, LK, LR, LS, LU, LY, MA, MD, ME, MG, MK, MN, MW, MX, MY, MZ, NA, NG, NI, NO, NZ, OM, PA, PE, PG, PH, PL, PT, QA, RO, RS, RU, RW, SA, SC, SD, SE, SG, SK, SL, SM, ST, SV, SY, TH, TJ, TM, TN, TR, TT, TZ, UA, UG, US, UZ, VC, VN, ZA, ZM, ZW.
- (84) Designated States (unless otherwise indicated, for every kind of regional protection available): ARIPO (BW, GH, GM, KE, LR, LS, MW, MZ, NA, RW, SD, SL, ST, SZ, TZ, UG, ZM, ZW), Eurasian (AM, AZ, BY, KG, KZ, RU, TJ, TM), European (AL, AT, BE, BG, CH, CY, CZ, DE, DK, EE, ES, FI, FR, GB, GR, HR, HU, IE, IS, IT, LT, LU, LV, MC, MK, MT, NL, NO, PL, PT, RO, RS, SE, SI, SK, SM, TR), OAPI (BF, BJ, CF, CG, CI, CM, GA, GN, GQ, GW, KM, ML, MR, NE, SN, TD, TG).

Published:
— with international search report (Art. 21(3))

(54) Title: PHYSICAL LAYER SYSTEM WITH SUPPORT FOR MULTIPLE ACTIVE WORK ORDERS AND/OR MULTIPLE ACTIVE TECHNICIANS

FIG. 1

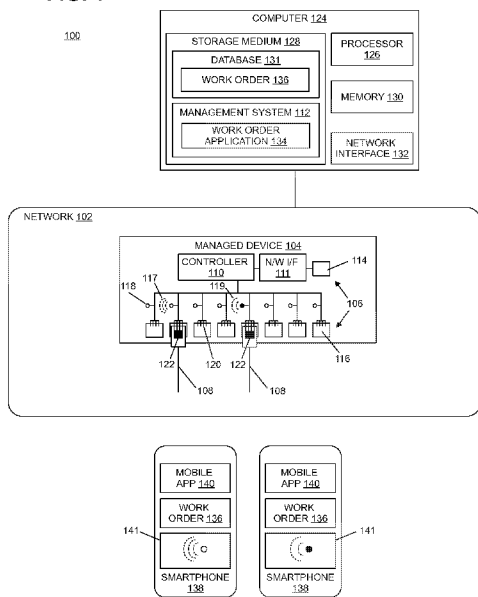

(57) Abstract: Multiple visual indications are provided at a device in connection with multiple work orders. Each work order involves a respective connection using the device. The multiple visual indications are provided simultaneously for at least a part of the time the visual indications are provided. In one implementation, the visual indications differ from one another. What each visual indication looks like is displayed on a respective portable device configured to display information about the work order associated with that visual indication.

WO 2015/035014 A1

PHYSICAL LAYER SYSTEM WITH SUPPORT FOR MULTIPLE ACTIVE
WORK ORDERS AND/OR MULTIPLE ACTIVE TECHNICIANS

CROSS-REFERENCE TO RELATED APPLICATIONS

[0001] This application claims the benefit of United States Provisional Patent Application Serial No. 61/873,610, filed on September 4, 2013, which is hereby incorporated herein by reference.

BACKGROUND

[0002] One common use of a physical layer management (PLM) system is to guide a technician in moving, adding, or changing a connection made at a patch panel or other device where connections are made using cables. This is commonly done as a part of a larger “work order” that includes one or more steps.

[0003] In one common implementation, the patch panel includes a light emitting diode for each port of the patch panel and a controller that interacts with a remotely located management system. To guide a technician in performing a step of a work order that affects a particular port of the patch panel, the management system can illuminate (or otherwise actuate) the light emitting diode that is associated with that port in order to visually identify the port for the technician. This is done to assist the technician in locating the correct port. That is, the light emitting diode is used to provide a visual indication of the affected port.

[0004] Such systems are typically designed to be used to guide a single technician in performing a single work order at a time. That is, such systems are not designed to guide multiple technicians in performing multiple work orders.

SUMMARY

[0005] One embodiment is directed to a system comprising a device that includes a plurality of ports to which cables can be attached and a plurality of visual indicators, each of which is configured to provide multiple visual indications. The system further comprises a management system communicatively coupled to the device, wherein the management system is configured to control the visual indicators. The management system is configured to cause the device to provide multiple visual indications at the device, each of the multiple visual indications being provided in connection with a

respective work order that involves a respective connection using the device. The system is configured to provide the multiple visual indications simultaneously for at least a part of the time each of the multiple visual indications is provided.

[0006] In one implementation, the system further comprises a first portable device configured to execute a first work order application that displays information about the first work order, and a second portable device configured to execute a second work order application that displays information about the second work order. The system is configured to provide the first and second visual indicators simultaneously for at least a part of the time the first visual indication is provided and for at least a part of the time the second visual indication is provided by doing the following: having the first visual indication differ from the second visual indication, in connection with displaying information about the first work order on the first portable device, displaying on the first portable device what the first visual indication looks like, and, in connection with displaying information about the second work order on the second portable device, displaying on the second portable device what the second visual indication looks like.

[0007] Another embodiment is directed to a method performed using a device comprising a plurality of ports to which cables can be attached and a plurality of visual indicators, each of which is configured to provide multiple visual indications. The method comprises providing a first visual indication at the device in connection with a first work order, wherein the first work order involves a first connection using the device, and providing a second visual indication at the device in connection with a second work order, wherein the second work order involves a second connection using the device. The first visual indication and the second visual indication are provided simultaneously for at least a part of the time the first visual indication is provided and for at least a part of the time the second visual indication is provided.

[0008] In one implementation, the first visual indication differs from the second visual indication. The method further comprises displaying what the first visual indication looks like on a first portable device configured to display information about the first work order, and displaying what the second visual indication looks like on a second portable device configured to display information about the second work order.

[0009] Another embodiment is directed to a device that comprises a plurality of ports to attach communication cables to the device and a plurality of visual indicators, each of the plurality of visual indicators configured to provide multiple visual indications. The device is configured to provide a first visual indication at the device in connection with a first work order. The first work order involves a first connection using the device. The device is configured to provide a second visual indication at the device in connection with a second work order. The second work order involves a second connection using the device. The first visual indication and the second visual indication are provided simultaneously for at least a part of the time the first visual indication is provided and for at least a part of the time the second visual indication is provided.

[0010] Another embodiment is directed to a program product tangibly stored on a non-transitory storage medium comprising instructions operable to cause at least one programmable processor to communicate with a device to cause the device to provide a first visual indication at the device in connection with a first work order. The device comprises a plurality of ports to which cables can be attached and a plurality of visual indicators, each of which is configured to provide multiple visual indications. The first work order involves a first connection using the device. The program product comprises instructions further operable to cause the programmable processor to communicate with the device to cause the device to provide a second visual indication at the device in connection with a second work order. The second work order involves a second connection using the device. The first visual indication and the second visual indication are provided simultaneously for at least a part of the time the first visual indication is provided and for at least a part of the time the second visual indication is provided.

DRAWINGS

[0011] FIG. 1 is a block diagram of one exemplary embodiment of a physical layer management system.

[0012] FIG. 2 is a flow diagram of one exemplary embodiment of a method of providing multiple visual indications at a managed device simultaneously in connection with multiple active work orders.

DETAILED DESCRIPTION

[0013] FIG. 1 is a block diagram of one exemplary embodiment of system 100. The system 100 is also referred to here as a “physical layer management” (PLM) system 100.

[0014] In the exemplary embodiment shown in FIG. 1, the PLM system 100 is used to guide technicians in moving, adding, or changing connections made in a network 102. The PLM system 100 can also be used to track physical layer information related to the network 102. As used herein, “physical layer information” comprises information about the cabling, connections, and communication links that exist in the network 102.

[0015] In the exemplary embodiment shown in FIG. 1, the network 102 includes various network elements or devices to which cables are connected. In the exemplary embodiment shown in FIG. 1, the network 102 includes a managed network element or device 104 that includes a plurality of ports 106 to which cables 108 can be attached.

[0016] More specifically, in the exemplary embodiment shown in FIG. 1, the managed device 104 comprises a patch panel (and is also referred to here as “managed patch panel” 104). The managed patch panel 104 is described here, in this exemplary embodiment, as being designed for use with copper twisted-pair CAT-5, 6, and 7 cables typically used to implement ETHERNET local area networks. The management device can be implemented in other ways (for example, as an optical distribution frame, splitter tray, switch, router, etc.). Also, the managed device 104 can be implemented for use with other types of cables (for example, other types of copper cables or fiber optic cables).

[0017] The managed device 104 includes a controller or other programmable processor 110 that is configured to communicate with a management system 112 over the network 102. The managed device 104 also includes a network interface 111 for communicatively coupling the managed device 104 (more specifically, the controller 110) to the network 102 and, ultimately, the management system 112. In the example shown in FIG. 1, the controller 110 and the network interface 111 are communicatively coupled to the network 102 and the management system 112 by

including a respective “management” or “non-service” port 114 in the managed device 104. The management port 114 is separate from the “service” ports 116 of that device 104. However, the controller 110 in the managed device 104 can be communicatively coupled to the network 102 using one or more of the “service” ports 116.

[0018] The managed device 104 includes one or more visual indicators 118 that are associated with each service port 116 of the managed device 104. In this exemplary embodiment, each visual indicator 118 is implemented using a light emitting diode (LED). Each LED 118 is coupled to the controller 110 in the managed device 104 so that the controller 110 (more specifically, the software executing on the controller 110) can control the LED 118.

[0019] In this example, the managed device 104 is configured so that each LED 118 can provide multiple visual indications. These multiple visual indications can be provided by having each LED 118 display multiple colors, blink at multiple rates, and/or blink in multiple patterns. Multiple visual indications can be provided in other ways.

[0020] A visual indication is provided in order to assist a technician in locating the associated service port 116 of the managed device 104.

[0021] In this example, the managed device 104 also includes, for each of the service ports 116, a storage device interface 120 that is configured so that, when a cable 108 is attached to that port 116, information can be read from any storage device 122 attached to the cable 108 by the controller 110 and communicated to the management system 112, which stores and/or updates information in a database or other data store 131 maintained by the management system 112.

[0022] In one example, each storage device interface 120 comprises a contact-based storage device interface that is configured for use in reading information from an Electrically Erasable Programmable Read-Only Memory (EEPROM) attached to each cable. In another example, each storage device interface 120 comprises a radio frequency identifier (RFID) interface that is configured for use in reading information from an RFID tag attached to a cable 108. That is, in such an RFID example, contact-

less interfaces are used for reading information from the storage devices 122 attached to the cables 108 and each storage device 122 is implemented using an RFID tag.

[0023] The managed device 104 can also include a plurality of presence sensors, each of which is configured for use in determining if a cable is attached to one of the service ports 116. Such presence sensors can be used in connection with the storage device interface 120 described above (for example, to determine when a cable 108 has been connected to a service port 116 and/or to determine if a cable 108 that does not have a storage device 122 attached to it has been connected to a service port 116). Also, such presence sensors can be used to infer information about connections made using the managed device 104 instead of or in addition to using information read from storage devices 122 attached to cables 108.

[0024] Power can be supplied to the active components of the managed device 104 in various ways (for example, by connecting the managed patch panel 104 to the standard AC power grid, using Power-Over-Ethernet technology, or in other ways).

[0025] In the exemplary embodiment shown in FIG. 1, the management system 112 is implemented as software that executes on one or more computers 124.

[0026] In the exemplary embodiment shown in FIG. 1, each computer 124 comprises one or more programmable processors 126 for executing the software. The software comprises program instructions that are stored (or otherwise embodied) on or in an appropriate non-transitory storage medium or media 128 (such as flash or other non-volatile memory, magnetic disc drives, and/or optical disc drives) from which at least a portion of the program instructions are read by the programmable processor 126 for execution thereby. Although the storage media 128 is shown in FIG. 1 as being included in, and local to, the respective computer 124, it is to be understood that remote storage media (for example, storage media that is accessible over the network 102) and/or removable media can also be used. Each computer 124 also includes memory 130 for storing the program instructions (and any related data) during execution by the programmable processor 126. Memory 130 comprises, in one implementation, any suitable form of random access memory (RAM) now known or later developed, such as dynamic random access memory (DRAM). In other embodiments, other types of memory are used. Each computer 124 also includes one

or more network interfaces 132 for communicatively coupling the computer 124 to the network 102.

[0027] In the example shown in FIG. 1, the management system 112 further includes an electronic work order application 134. The electronic work application 134 is used to construct electronic work orders 136. Each electronic work 136 specifies one or more steps that are to be carried out by a technician at a particular location. For example, an electronic work order 136 can indicate that one or more connections implemented using the service ports 116 of the managed device 104 should be added, removed, and/or changed. For steps that involve adding, removing, and/or changing connections made at the service ports 116 of the managed device 104, the information that is read from the associated storage devices 122 and communicated to the management system 112 can be used by the electronic work order application 134 to verify that the specified connection has been added, removed, and/or changed correctly.

[0028] As described in more detail below, the visual indicators 118 associated with the service ports 116 of the managed device 104 can be actuated in order to guide a technician in carrying out the steps of electronic work orders 136.

[0029] In this example, each electronic work order 136 is communicated to a portable device 138 that is carried by a technician that has been assigned to carry out that electronic work order 136. In this example, the portable device 138 is implemented using smartphone (and is also referred to here as smartphone 138). However, it is to be understood that each portable device 138 can be implemented in other ways (for example, using tablet computers, laptop computers, or similar devices).

[0030] In this example, each smartphone 138 is configured to execute a mobile application 140. The mobile application 140 is configured to communicate with the electronic work order application 134 and the management system 112 and to receive the electronic work orders 136. The mobile application 140 comprises program instructions that are stored (or otherwise embodied) on or in an appropriate non-transitory storage medium or media from which at least a portion of the program

instructions are read by at least one programmable processor included in the smartphone 138 for execution thereby.

[0031] Each electronic work order 136 can be communicated wirelessly to the smartphone 138 over the Internet (for example, via a cellular or wireless local area network to which the smartphone 138 is wirelessly connected). Each electronic work order 136 can also be communicated to the smartphone 138 in other ways (for example, using a wired connection with the smartphone 138).

[0032] In the exemplary embodiment shown in FIG. 1, the system 100 is configured to support multiple active work orders 136 and multiple technicians working at the device 104 at the same time. The example shown in FIGS. 1 and 2 is described as involving two active work orders 136 and two portable devices 138; however, it is to be understood that this is merely exemplary, and that different numbers of multiple active work orders and portable devices 138 can be used.

[0033] The management system 112 and managed device 104 are configured so that multiple visual indications can be provided at the managed device 104 at the same time using the visual indicators 118 in connection with multiple work orders 136.

[0034] Each of the multiple visual indications is provided in a different way from the other visual indications that are provided at the same time (for example, by having the associated LED 118 be illuminated using a different color, a different blinking rate, and/or different blinking pattern). Each visual indication is provided in connection with a different work order 136.

[0035] A technician that is performing a given work order 136 uses the mobile application 140 executing on a smartphone 138 to help the technician perform the work order 136. The mobile application 140 and the management system 112 are configured so that when a visual indication is provided at the managed device 104, the mobile application 140 displays on the smartphone 138 what that particular visual indication looks like (for example, by displaying on the smartphone 138 an image 141 that shows the color, blink rate, and blink pattern that is used to provide that visual indication). In this way, the technician is able to determine which visual indication is associated with the work order 136 that the technician is performing at that time. As a result, multiple technicians are able to work on multiple active work orders 136 at the

same time at a given managed device 104, with multiple visual indications being provided simultaneously at the managed device 104.

[0036] FIG. 2 is a flow diagram of one exemplary embodiment of a method 200 of providing multiple visual indications at a managed device simultaneously in connection with multiple active work orders. The exemplary embodiment of method 200 shown in FIG. 2 is described here as being implemented using the system 100 shown in FIG. 1, though it is to be understood that other embodiments can be implemented in other ways. Moreover, the blocks of the flow diagram shown in FIG. 2 have been arranged for ease of explanation; however, it is to be understood that this arrangement is merely exemplary, and it should be recognized that the processing associated with method 200 (and the blocks shown in FIG. 2) can occur in any order (for example, using standard event-driven programming techniques).

[0037] Moreover, as noted above the example shown in FIGS. 1 and 2 is described as involving two active work orders 136 and two portable devices 138; however, it is to be understood that this is merely exemplary, and that different numbers of multiple active work orders and portable devices 138 can be used.

[0038] Method 200 comprises providing a first visual indication 117 (shown in FIG. 1) at the managed device 104 in connection with a first work order 136 (block 202) and providing a second visual indication 119 (shown in FIG. 1) at the managed device 104 in connection with a second work order (block 204).

[0039] The first work order involves a first connection using the managed device 104 (for example, involving a first service port 116 of the managed device 104), and the second work order involves a second connection using the managed device 104 (for example, involving a second service port 116 of the managed device 104).

[0040] The first visual indication 117 and the second visual indication 119 are provided simultaneously for at least a part of the time the first visual indication 117 is provided and for at least a part of the time the second visual indication 119 is provided.

[0041] Each of the first and second electronic work orders 136, in this example, is communicated to the mobile application 140 executing on the respective smartphone

138 used by the technician that is assigned to perform that electronic work order 136. Each electronic work order 136 can be wirelessly communicated from the electronic work order application 134 to the respective smartphone 138 (for example, using a cellular or wireless local area network communication link) or using a wired connection to the Internet, a local area network, or a direct connection between the smartphone 138 and the computer 124 on which the electronic work order application 134 executes.

[0042] After each of the first and second electronic work orders 136 has been downloaded to the mobile application 140 on the respective smartphone 138, the relevant technician can use the mobile application 140 to view the electronic work order 136 and the steps included in the electronic work order 136. After the technicians have travelled to the location where the managed device 104 is installed, the technicians can use the mobile application 140 executing on the smartphones 138 to assist the technicians in carrying out the steps in the work orders 136.

[0043] In this example, the management system 112 controls the providing of the first and second visual indications 117 and 119. To provide the first visual indication 117 at the managed device 104, the management system 112 sends a message to the controller 110 in the managed device 104 indicating that the relevant LED 118 in the managed device 104 associated with the relevant step of the first work order (for example, an LED 118 associated with a service port 116 affected by that step) should be illuminated in a particular manner (for example, should be illuminated using a particular color, blink rate, and/or blink pattern). Likewise, to provide the second visual indication 119 at the managed device 104, the management system 112 sends a message to the controller 110 in the managed device 104 indicating that the relevant LED 118 in the managed device 104 associated with the relevant step of the second work order (for example, an LED 118 associated with a service port 116 affected by that step) should be illuminated in a particular manner (for example, should be illuminated using a particular color, blink rate, and/or blink pattern).

[0044] In this example, the first visual indication 117 differs from the second visual indication 119.

[0045] The method 200 further comprises displaying what the first visual indication 117 looks like on a first portable device 138 configured to display information about the first work order 136 (block 206) and displaying what the second visual indication 119 looks like on a second portable device 138 configured to display information about the second work order 136 (block 208).

[0046] As noted above, in this example, the first and second portable devices 138 are implemented using first and second smartphones 138 (though the portable devices 138 can be implemented in other ways).

[0047] In this example, the management system 112 is communicatively coupled to the first and second smartphones 138 and is configured to control the displaying of information about the first work order 136 on the first smartphone 138 and the displaying of information about the second work order 136 on the second smartphone 138 by sending appropriate messages to the smartphones 138 (and the mobile applications 140 executing thereon).

[0048] In this example, the mobile application 140 executing on the first smartphone 138 displays on the first smartphone 138 what the first visual indication 117 looks like (for example, by displaying on that smartphone 138 an image that shows the color, blink rate, and blink pattern that is used to provide the first visual indication 117). Likewise, in this example, the mobile application 140 executing on the second smartphone 138 displays on the second smartphone 138 what the second visual indication 119 looks like (for example, by displaying on that smartphone 138 an image 142 that shows the color, blink rate, and blink pattern that is used to provide the second visual indication 119). One example how this done is shown in FIG. 1.

[0049] In this way, each technician is able to determine which visual indication is associated with the particular work order 136 that the technician is performing at that time. As a result, multiple technicians are able to work on multiple active work orders 136 at the same time at a given managed device 104, with multiple visual indications being provided simultaneously at the managed device 104.

[0050] A number of embodiments have been described. Nevertheless, it will be understood that various modifications to the described embodiments may be made without departing from the spirit and scope of the claimed invention.

EXAMPLE EMBODIMENTS

[0051] Example 1 includes a system comprising: a device that comprises: a plurality of ports to which cables can be attached; and a plurality of visual indicators, each of which is configured to provide multiple visual indications; wherein the system further comprises a management system communicatively coupled to the device, wherein the management system is configured to control the visual indicators; wherein the management system is configured to cause the device to provide multiple visual indications at the device, each of the multiple visual indications being provided in connection with a respective work order that involves a respective connection using the device; wherein the system is configured to provide the multiple visual indications simultaneously for at least a part of the time each of the multiple visual indications is provided.

[0052] Example 2 includes the system of Example 1, further comprising: multiple portable devices, each of the multiple portable devices configured to execute a respective work order application that displays information about a respective work orders; and wherein the system is configured to provide the multiple visual indications simultaneously for at least a part of the time each of the multiple visual indications is provided by doing the following: having the multiple visual indications differ from one another; and for each of the multiple visual indications, in connection with displaying, on a respective one of the multiple portable devices, information about a respective work order, displaying on the respective portable device what the respective visual indication looks like.

[0053] Example 3 includes the system of Example 2, wherein the management system is communicatively coupled to the portable devices and is configured to control the displaying of information about the work orders on the portable devices.

[0054] Example 4 includes the system of any of the Examples 1-3, wherein the device is configured so that for each of the plurality of ports, when a cable is attached to that port, information is read from any storage device attached to the cable and communicated to the management system for storage thereby.

[0055] Example 5 includes the system of any of the Examples 1-4, wherein the management system is configured to monitor the performance of the work orders.

[0056] Example 6 includes the system of any of the Examples 1-5, wherein the device comprises at least one of a patch panel, an optical distribution frame, and a splitter tray.

[0057] Example 7 includes the system of any of the Examples 1-6, wherein each of the visual indicators comprises a light emitting diode.

[0058] Example 8 includes the system of any of the Examples 1-7, wherein the device is configured so that each of the plurality of visual indicators provides the multiple visual indications by doing one or more of: displaying multiple colors; blinking at differing rates; and blinking in multiple patterns.

[0059] Example 9 includes the system of any of the Examples 1-8, wherein the device further comprises one or more of: a plurality of contact-based storage device interfaces, each of which is configured for use in reading information from a respective storage device attached to a cable when attached to one of the ports; a plurality of RFID interfaces, each of which is configured for use in reading information from a respective RFID tag attached to a cable when attached to one of the ports; and a plurality of presence sensors, each of which is configured for use in determining if a cable is attached to one of the ports.

[0060] Example 10 includes the system of any of the Examples 1-9, wherein the device comprises a controller and a network interface to communicatively couple the controller to the management system.

[0061] Example 11 includes a method performed using a device comprising a plurality of ports to which cables can be attached and a plurality of visual indicators, each of which is configured to provide multiple visual indications, the method comprising: providing a first visual indication at the device in connection with a first work order, wherein the first work order involves a first connection using the device; and providing a second visual indication at the device in connection with a second work order, wherein the second work order involves a second connection using the device; wherein the first visual indication and the second visual indication are provided simultaneously for at least a part of the time the first visual indication is provided and for at least a part of the time the second visual indication is provided.

[0062] Example 12 includes the method of Example 11, wherein the first visual indication differs from the second visual indication, and wherein the method further comprises: displaying what the first visual indication looks like on a first portable device configured to display information about the first work order; and displaying what the second visual indication looks like on a second portable device configured to display information about the second work order.

[0063] Example 13 includes the method of any of the Examples 11-12, wherein a management system is communicatively coupled to the first and second portable devices and is configured to control the displaying of information about the first work order on the first portable device and the displaying of information about the second work order on the second portable device.

[0064] Example 14 includes the method of any of the Examples 11-13, further comprising: for each of the plurality of ports, when a cable is attached to that port, reading information from any storage device attached to the cable and communicating the information to a management system for storage thereby.

[0065] Example 15 includes the method of any of the Examples 11-14, wherein a management system is communicatively coupled to the device and is configured to monitor the performance of the first and second work orders.

[0066] Example 16 includes the method of any of the Examples 11-15, wherein the device is configured so that each of the plurality of visual indicators provides the multiple visual indications by doing one or more of: displaying multiple colors; blinking at differing rates; and blinking in multiple patterns.

[0067] Example 17 includes a device comprising: a plurality of ports to attach communication cables to the device; and a plurality of visual indicators, each of the plurality of visual indicators configured to provide multiple visual indications; wherein the device is configured to provide a first visual indication at the device in connection with a first work order, wherein the first work order involves a first connection using the device; wherein the device is configured to provide a second visual indication at the device in connection with a second work order, wherein the second work order involves a second connection using the device; and wherein the first visual indication and the second visual indication are provided simultaneously for

at least a part of the time the first visual indication is provided and for at least a part of the time the second visual indication is provided.

[0068] Example 18 includes the device of Example 17, wherein the device is configured so that for each of the plurality of ports, when a cable is attached to that port, information is read from any storage device attached to the cable and communicated to a management system for storage thereby.

[0069] Example 19 includes the device of any of the Examples 17-18, further comprising: a controller communicatively coupled to the plurality of visual indicators; and a network interface to communicatively couple the controller to a management system.

[0070] Example 20 includes the device of any of the Examples 17-19, further comprising one or more of: a plurality of contact-based storage device interfaces, each of which is configured for use in reading information from a respective storage device attached to a cable when attached to one of the ports; a plurality of RFID interfaces, each of which is configured for use in reading information from a respective RFID tag attached to a cable when attached to one of the ports; and a plurality of presence sensors, each of which is configured for use in determining if a cable is attached to one of the ports.

[0071] Example 21 includes the device of any of the Examples 17-20, wherein the device comprises at least one of patch panel, an optical distribution frame, and splitter tray.

[0072] Example 22 includes the device of any of the Examples 17-21, wherein each of the visual indicators comprises a light emitting diode.

[0073] Example 23 includes the device of any of the Examples 17-22, wherein the device is configured so that each of the plurality of visual indicators provides the multiple visual indications by doing one or more of: displaying multiple colors; blinking at differing rates; and blinking in multiple patterns.

[0074] Example 24 includes a program product tangibly stored on a non-transitory storage medium comprising instructions operable to cause at least one programmable

processor to: communicate with a device to cause the device to provide a first visual indication at the device in connection with a first work order, wherein the device comprises a plurality of ports to which cables can be attached and a plurality of visual indicators, each of which is configured to provide multiple visual indications, and wherein the first work order involves a first connection using the device; and communicate with the device to cause the device to provide a second visual indication at the device in connection with a second work order, wherein the second work order involves a second connection using the device; wherein the first visual indication and the second visual indication are provided simultaneously for at least a part of the time the first visual indication is provided and for at least a part of the time the second visual indication is provided.

[0075] Example 25 includes the program product of Example 24, wherein the first visual indication differs from the second visual indication, and wherein the program product comprises instructions operable to cause the programmable processor to: communicate with a first portable device to cause the first portable device to display of what the first visual indication looks like on the first portable device configured to display information about the first work order; and communicate with a second portable device to cause the second portable device to display of what the second visual indication looks like on the second portable device configured to display information about the second work order.

[0076] Example 26 includes the program product of any of the Examples 24-25, wherein the device is configured so that each of the plurality of visual indicators provides the multiple visual indications by doing one or more of: displaying multiple colors; blinking at differing rates; and blinking in multiple patterns.

CLAIMS

1. A system comprising:
 - a device that comprises:
 - a plurality of ports to which cables can be attached; and
 - a plurality of visual indicators, each of which is configured to provide multiple visual indications;
 - a management system communicatively coupled to the device, wherein the management system is configured to control the visual indicators;
 - wherein the management system is configured to cause the device to provide multiple visual indications at the device, each of the multiple visual indications being provided in connection with a respective work order that involves a respective connection using the device;
 - wherein the system is configured to provide the multiple visual indications simultaneously for at least a part of the time each of the multiple visual indications is provided.
2. The system of claim 1, further comprising:
 - multiple portable devices, each of the multiple portable devices configured to execute a respective work order application that displays information about a respective work order; and
 - wherein the system is configured to provide the multiple visual indications simultaneously for at least a part of the time each of the multiple visual indications is provided by doing the following:
 - having the multiple visual indications differ from one another; and
 - for each of the multiple visual indications, in connection with displaying, on a respective one of the multiple portable devices, information about a respective work order, displaying on the respective portable device what the respective visual indication looks like.
3. The system of claim 2, wherein the management system is communicatively coupled to the portable devices and is configured to control the displaying of information about the work orders on the portable devices.

4. The system of claim 1, wherein the device is configured so that for each of the plurality of ports, when a cable is attached to that port, information is read from any storage device attached to the cable and communicated to the management system for storage thereby.
5. The system of claim 1, wherein the management system is configured to monitor the performance of the work orders.
6. The system of claim 1, wherein the device comprises at least one of a patch panel, an optical distribution frame, and a splitter tray.
7. The system of claim 1, wherein each of the visual indicators comprises a light emitting diode.
8. The system of claim 1, wherein the device is configured so that each of the plurality of visual indicators provides the multiple visual indications by doing one or more of:
 - displaying multiple colors;
 - blinking at differing rates; and
 - blinking in multiple patterns.
9. The system of claim 1, wherein the device further comprises one or more of:
 - a plurality of contact-based storage device interfaces, each of which is configured for use in reading information from a respective storage device attached to a cable when attached to one of the ports;
 - a plurality of RFID interfaces, each of which is configured for use in reading information from a respective RFID tag attached to a cable when attached to one of the ports; and
 - a plurality of presence sensors, each of which is configured for use in determining if a cable is attached to one of the ports.
10. The system of claim 1, wherein the device comprises a controller and a network interface to communicatively couple the controller to the management system.

11. A method performed using a device comprising a plurality of ports to which cables can be attached and a plurality of visual indicators, each of which is configured to provide multiple visual indications, the method comprising:

providing a first visual indication at the device in connection with a first work order, wherein the first work order involves a first connection using the device; and

providing a second visual indication at the device in connection with a second work order, wherein the second work order involves a second connection using the device;

wherein the first visual indication and the second visual indication are provided simultaneously for at least a part of the time the first visual indication is provided and for at least a part of the time the second visual indication is provided.

12. The method of claim 11, wherein the first visual indication differs from the second visual indication, and wherein the method further comprises:

displaying what the first visual indication looks like on a first portable device configured to display information about the first work order; and

displaying what the second visual indication looks like on a second portable device configured to display information about the second work order.

13. The method of claim 11, wherein a management system is communicatively coupled to the first and second portable devices and is configured to control the displaying of information about the first work order on the first portable device and the displaying of information about the second work order on the second portable device.

14. The method of claim 11, further comprising:

for each of the plurality of ports, when a cable is attached to that port, reading information from any storage device attached to the cable and communicating the information to a management system for storage thereby.

15. The method of claim 11, wherein a management system is communicatively coupled to the device and is configured to monitor the performance of the first and second work orders.

16. The method of claim 11, wherein the device is configured so that each of the plurality of visual indicators provides the multiple visual indications by doing one or more of:

- displaying multiple colors;
- blinking at differing rates; and
- blinking in multiple patterns.

17. A device comprising:

- a plurality of ports to attach communication cables to the device; and
- a plurality of visual indicators, each of the plurality of visual indicators configured to provide multiple visual indications;

- wherein the device is configured to provide a first visual indication at the device in connection with a first work order, wherein the first work order involves a first connection using the device;

- wherein the device is configured to provide a second visual indication at the device in connection with a second work order, wherein the second work order involves a second connection using the device; and

- wherein the first visual indication and the second visual indication are provided simultaneously for at least a part of the time the first visual indication is provided and for at least a part of the time the second visual indication is provided.

18. The device of claim 17, wherein the device is configured so that for each of the plurality of ports, when a cable is attached to that port, information is read from any storage device attached to the cable and communicated to a management system for storage thereby.

19. The device of claim 17, further comprising:

- a controller communicatively coupled to the plurality of visual indicators; and
- a network interface to communicatively couple the controller to a management system.

20. The device of claim 17, further comprising one or more of:

a plurality of contact-based storage device interfaces, each of which is configured for use in reading information from a respective storage device attached to a cable when attached to one of the ports;

a plurality of RFID interfaces, each of which is configured for use in reading information from a respective RFID tag attached to a cable when attached to one of the ports; and

a plurality of presence sensors, each of which is configured for use in determining if a cable is attached to one of the ports.

21. The device of claim 17, wherein the device comprises at least one of patch panel, an optical distribution frame, and splitter tray.

22. The device of claim 17, wherein each of the visual indicators comprises a light emitting diode.

23. The device of claim 17, wherein the device is configured so that each of the plurality of visual indicators provides the multiple visual indications by doing one or more of:

displaying multiple colors;
blinking at differing rates; and
blinking in multiple patterns.

24. A program product tangibly stored on a non-transitory storage medium comprising instructions operable to cause at least one programmable processor to:

communicate with a device to cause the device to provide a first visual indication at the device in connection with a first work order, wherein the device comprises a plurality of ports to which cables can be attached and a plurality of visual indicators, each of which is configured to provide multiple visual indications, and wherein the first work order involves a first connection using the device; and

communicate with the device to cause the device to provide a second visual indication at the device in connection with a second work order, wherein the second work order involves a second connection using the device;

wherein the first visual indication and the second visual indication are provided simultaneously for at least a part of the time the first visual indication is provided and for at least a part of the time the second visual indication is provided.

25. The program product of claim 24, wherein the first visual indication differs from the second visual indication, and wherein the program product comprises instructions operable to cause the programmable processor to:

- communicate with a first portable device to cause the first portable device to display of what the first visual indication looks like on the first portable device configured to display information about the first work order; and

- communicate with a second portable device to cause the second portable device to display of what the second visual indication looks like on the second portable device configured to display information about the second work order.

26. The program product of claim 24, wherein the device is configured so that each of the plurality of visual indicators provides the multiple visual indications by doing one or more of:

- displaying multiple colors;
- blinking at differing rates; and
- blinking in multiple patterns.

FIG. 1

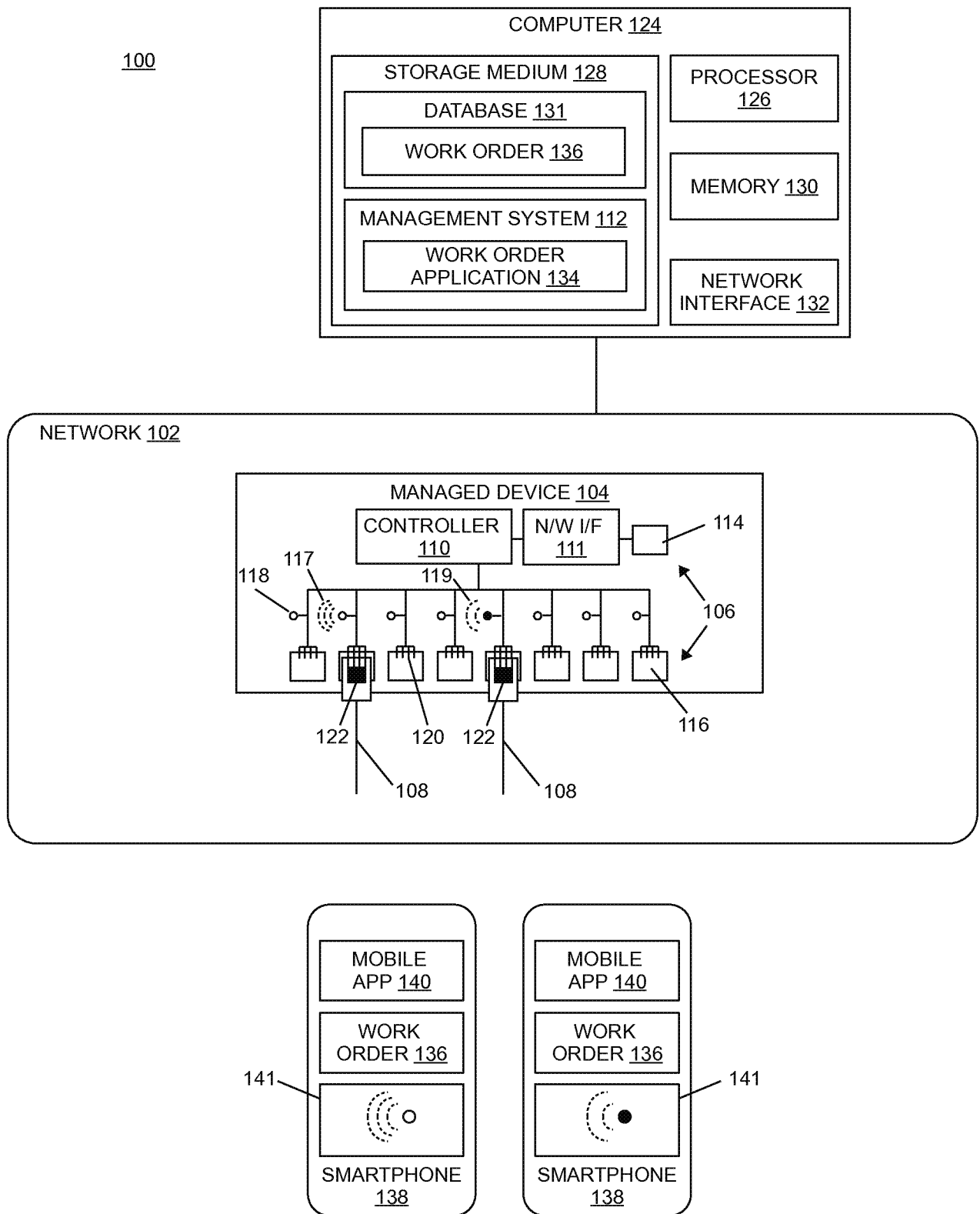

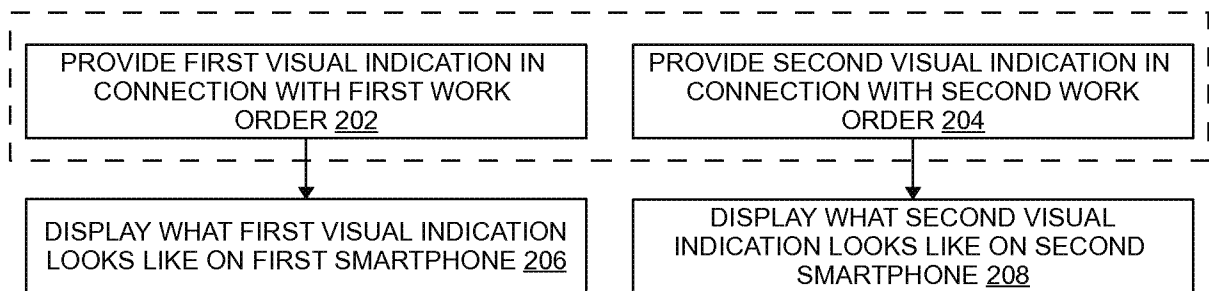

200

FIG. 2

A. CLASSIFICATION OF SUBJECT MATTER**G06Q 50/04(2012.01)i**

According to International Patent Classification (IPC) or to both national classification and IPC

B. FIELDS SEARCHEDMinimum documentation searched (classification system followed by classification symbols)
G06Q 50/04; G06F 15/173; G08B 5/36; H04L 12/24; H04L 12/26; H04L 12/28; H01R 13/625Documentation searched other than minimum documentation to the extent that such documents are included in the fields searched
Korean utility models and applications for utility models
Japanese utility models and applications for utility modelsElectronic data base consulted during the international search (name of data base and, where practicable, search terms used)
eKOMPASS(KIPO internal) & Keywords: port, visual indicator, LED, work order, simultaneously**C. DOCUMENTS CONSIDERED TO BE RELEVANT**

Category*	Citation of document, with indication, where appropriate, of the relevant passages	Relevant to claim No.
Y	US 2013-0128758 A1 (JOSEPH POLLAND) 23 May 2013 See abstract, paragraphs [0016], [0027], [0032], [0036]-[0038], claims 1, 3-4, 8, 10 and figures 1-3.	1-26
Y	KR 10-1216682 B1 (TEKMO CO., LTD.) 10 January 2013 See abstract, paragraphs [0015], [0024], [0046]-[0050], [0068]-[0072], claims 1, 8 and figures 1-2, 4-7.	1-26
A	US 2013-0024563 A1 (KEISUKE TORIGOE et al.) 24 January 2013 See abstract, paragraphs [0036], [0042], [0054]-[0057], claims 1-3, 7, 15-19 and figures 1-2, 5, 12, 14.	1-26
A	US 2006-0160395 A1 (DANIEL W. MACAULEY et al.) 20 July 2006 See abstract, claims 1-5 and figures 3-4.	1-26
A	KR 10-2010-0018708 A (DASAN NETWORKS INC.) 18 February 2010 See abstract, paragraphs [0050]-[0058], claims 1-5, 8 and figures 1a-3.	1-26

 Further documents are listed in the continuation of Box C. See patent family annex.

* Special categories of cited documents:

"A" document defining the general state of the art which is not considered to be of particular relevance

"E" earlier application or patent but published on or after the international filing date

"L" document which may throw doubts on priority claim(s) or which is cited to establish the publication date of another citation or other special reason (as specified)

"O" document referring to an oral disclosure, use, exhibition or other means

"P" document published prior to the international filing date but later than the priority date claimed

"T" later document published after the international filing date or priority date and not in conflict with the application but cited to understand the principle or theory underlying the invention

"X" document of particular relevance; the claimed invention cannot be considered novel or cannot be considered to involve an inventive step when the document is taken alone

"Y" document of particular relevance; the claimed invention cannot be considered to involve an inventive step when the document is combined with one or more other such documents, such combination being obvious to a person skilled in the art

"&" document member of the same patent family

Date of the actual completion of the international search

18 December 2014 (18.12.2014)

Date of mailing of the international search report

18 December 2014 (18.12.2014)

Name and mailing address of the ISA/KR

International Application Division
Korean Intellectual Property Office
189 Cheongsu-ro, Seo-gu, Daejeon Metropolitan City, 302-701,
Republic of Korea

Facsimile No. +82-42-472-7140

Authorized officer

OH, Eung Gie

Telephone No. +82-42-481-8744



INTERNATIONAL SEARCH REPORT

Information on patent family members

International application No.

PCT/US2014/054042

Patent document cited in search report	Publication date	Patent family member(s)	Publication date
US 2013-0128758 A1	23/05/2013	AU 2012-340634 A1 EP 2781055 A1 WO 2013-078389 A1	12/06/2014 24/09/2014 30/05/2013
KR 10-1216682 B1	10/01/2013	None	
US 2013-0024563 A1	24/01/2013	CN 102783095 A EP 2541844 A1 EP 2541844 A4 JP 05532360 B2 JP 05610250 B2 JP 2014-150582 A KR 10-1415389 B1 KR 10-2012-0123462 A TW 201212600 A WO 2011-102512 A1 WO 2011-102512 A1	14/11/2012 02/01/2013 14/05/2014 25/06/2014 22/10/2014 21/08/2014 04/07/2014 08/11/2012 16/03/2012 25/08/2011 25/08/2011
US 2006-0160395 A1	20/07/2006	AU 2005-319313 A1 AU 2005-319313 B2 CN 101124828 A EP 1829388 A1 IL 184090D0 WO 2006-069071 A1	29/06/2006 17/09/2009 13/02/2008 05/09/2007 31/10/2007 29/06/2006
KR 10-2010-0018708 A	18/02/2010	KR 10-0986977 B1	11/10/2010