



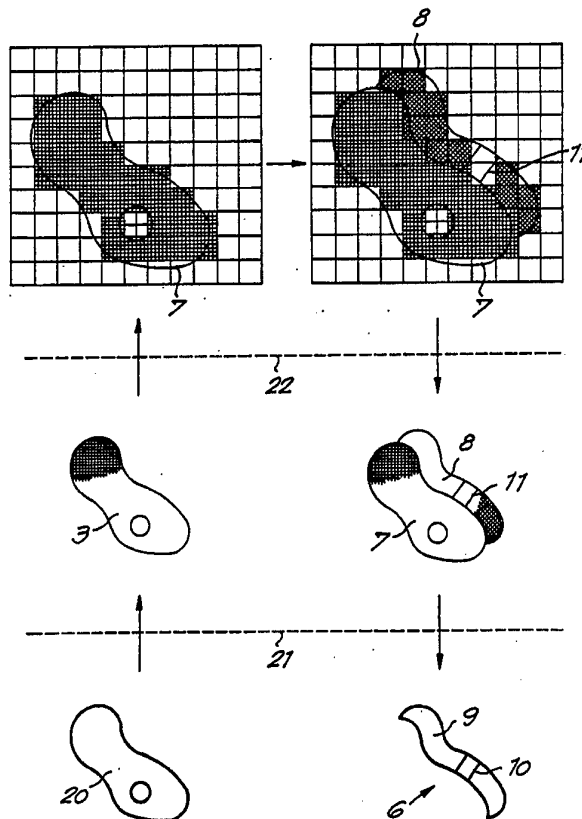
INTERNATIONAL APPLICATION PUBLISHED UNDER THE PATENT COOPERATION TREATY (PCT)

<p>(51) International Patent Classification <sup>6</sup> : <b>G06T 15/00</b></p>	<p><b>A1</b></p>	<p>(11) International Publication Number: <b>WO 95/28688</b> (43) International Publication Date: 26 October 1995 (26.10.95)</p>
<p>(21) International Application Number: PCT/BE95/00033 (22) International Filing Date: 11 April 1995 (11.04.95) (30) Priority Data: 9400399 19 April 1994 (19.04.94) BE (71) Applicant (for all designated States except US): MATERI-ALISE, NAAMLOZE VENNOOTSCHAP [BE/BE]; Jan Vander Vorstlaan 19, B-3040 Huldenberg (BE). (72) Inventors; and (75) Inventors/Applicants (for US only): SWAELENS, Bart [BE/BE]; Peulisstraat 12, B-2580 Putte (BE). VAN-CRAEN, Wilfried [BE/BE]; Jan Vander Vorstlaan 19, B-3040 Huldenberg (BE). (74) Agent: DONNÉ, Eddy; Bureau M.F.J. Bockstael n.v., Aren-bergstraat 13, B-2000 Antwerpen (BE).</p>		<p>(81) Designated States: AU, CA, CN, JP, US, European patent (AT, BE, CH, DE, DK, ES, FR, GB, GR, IE, IT, LU, MC, NL, PT, SE).  <b>Published</b> <i>With international search report.</i></p>

(54) Title: METHOD FOR MAKING A PERFECTED MEDICAL MODEL ON THE BASIS OF DIGITAL IMAGE INFORMATION OF A PART OF THE BODY

(57) Abstract

Method for making a perfected medical model on the basis of digital image information of a part of the body, according to which this image information of a part of the body is converted, by means of what is called the rapid prototyping technique and thus with a processing unit (4) and a rapid prototyping machine (5), into a basic model (9) of which at least a part perfectly shows the positive or negative form of at least a part of the part of the body, characterized in that at least a functional element (10) with a useful function is added to the basic model (6) as a function of the digital information and possibly as a function of additional external information.



**FOR THE PURPOSES OF INFORMATION ONLY**

Codes used to identify States party to the PCT on the front pages of pamphlets publishing international applications under the PCT.

AT	Austria	GB	United Kingdom	MR	Mauritania
AU	Australia	GE	Georgia	MW	Malawi
BB	Barbados	GN	Guinea	NE	Niger
BE	Belgium	GR	Greece	NL	Netherlands
BF	Burkina Faso	HU	Hungary	NO	Norway
BG	Bulgaria	IE	Ireland	NZ	New Zealand
BJ	Benin	IT	Italy	PL	Poland
BR	Brazil	JP	Japan	PT	Portugal
BY	Belarus	KE	Kenya	RO	Romania
CA	Canada	KG	Kyrgystan	RU	Russian Federation
CF	Central African Republic	KP	Democratic People's Republic of Korea	SD	Sudan
CG	Congo	KR	Republic of Korea	SE	Sweden
CH	Switzerland	KZ	Kazakhstan	SI	Slovenia
CI	Côte d'Ivoire	LI	Liechtenstein	SK	Slovakia
CM	Cameroon	LU	Luxembourg	SN	Senegal
CN	China	LV	Latvia	TD	Chad
CS	Czechoslovakia	MG	Madagascar	TG	Togo
CZ	Czech Republic	ML	Mali	TJ	Tajikistan
DE	Germany	MN	Mongolia	TT	Trinidad and Tobago
DK	Denmark			UA	Ukraine
ES	Spain			US	United States of America
FI	Finland			UZ	Uzbekistan
FR	France			VN	Viet Nam
GA	Gabon				

Method for making a perfected medical model on the basis of digital image information of a part of the body.

5

The invention concerns a method for making a perfected medical model on the basis of digital image information of a part of the body, according to which this image information of a part of the body is converted, by means of what is called the rapid prototyping technique and thus with a processing unit and a rapid prototyping machine, into a basic model of which at least a part perfectly shows the positive or negative form of at least a part of the part of the body.

15

By rapid prototyping technique should be understood all techniques whereby an object is built layer by layer or point per point by adding or hardening material (also called free-form manufacturing). The best known techniques of this type are: stereo lithography and related techniques, whereby for example a basin with liquid synthetic material is selectively cured layer by layer by means of a computer-controlled electromagnetic beam; selective laser sintering, whereby powder particles are sintered by means of an electromagnetic beam or are welded together according to a specific pattern; or fused deposition modelling, whereby a synthetic material is fused and is stacked according to a line pattern.

30 The digital image information can be provided by a computer tomography scanner.

The model produced up to now according to the above-mentioned technique, can be a model which is an exact

copy of the part of the body, for example a piece of bone, and upon which a surgery operation can be practised, or it can be a prosthesis which fits perfectly to the part of the body.

5

However, the models produced up to now, including three-dimensional images, do not take advantage of all the information contained in the image information. They form a perfect copy of the part of the body, but they do not contain any additional functional elements.

10

Functional elements, such as an opening indicating the place and direction for boring, can be added manually, but not as a function of the image information. At the time when these models are made, the grey value data of the image information are lost. However, these grey value data contain clinical data which are important for the use of the models. Such clinical data are for example the muscles and tendons which have to be taken into account when designing a prosthesis. These muscles and tendons are visible in the images, but not in the three-dimensional model, nor when working with segmented contours/surfaces in CAD-applications.

15

20

The manipulation of digital image data during the preparation of a surgery operation, for example, is known as such. It is possible, for example, to determine the position and direction of an implant on the images or to simulate surgeries. However, there is no connection with reality and, by lack of reference, these prepared image data cannot be used in practice. The image information is not used to the full.

30

As for the application of dental implants, attempts have

already been made to use teeth of a provisional prosthesis as a reference. This provisional prosthesis is made on the basis of a mould. With a reconstruction by means of computer tomography scanner images on the basis of planes in which the bone is clearly visible, what is called a dental scan, one can see whether the position and the angle of the provisional teeth are correct in relation to the underlying bone, and one can make corrections. However, this is a time-consuming method.

Sometimes, a template is made on the basis of the mould and this template is used during the surgery. Only surface data are used hereby, so that part of the information of the dental scan remains unused.

Another method consists in making a model of the jaw by means of the rapid prototyping technique and to make a template on the basis of this model which is used during the surgery. The information of the digital image of the teeth (the dental scan) cannot be used either with this method.

The invention aims to remedy these disadvantages and to provide a method for making a perfected medical model on the basis of digital image information of a body part whereby the image information can be optimally used and can be put to use in practice.

This aim is reached according to the invention as at least a functional element with a useful function is added to the basic model, as a function of the digital information and possibly as a function of additional external information.

By subsequently converting the image with the additional information in information for the control of a rapid prototyping machine, there is a feedback of the medical data to reality and a perfected model is obtained which  
5 does not only have the shape of a certain part of the body, such as a ragged bone shape, and thus provides a perfect reference, but which also contains artificial elements which are added as a function of the image information and of possible new additional information,  
10 and which have a useful function.

In a particular embodiment of the invention, the functional element is added as a function of the digital image information in the form in which all medical data  
15 are visible.

Such a form of the image information consists of the grey value information.

In a peculiar embodiment of the invention, the  
20 information on the basis of which the functional element is determined is processed factually in the perfected model by means of a voxel oriented computer system.

Via contour generation (segmentation/interpolation), one  
25 can switch from image processing to for example stereo lithography.

Possible new information added from outside to determine the functional element must then also be presented as  
30 voxels or contours.

The functional element with a useful function can be a shape, a colour or a texture.

This useful function can be the indication of a position, a direction, a length or an angle which are important during a surgery, the formation of a point of attachment, the formation of a filling for a certain defect, a  
5 prosthetic function, etc.

A useful function can for example also be facilitating the identification of a model or of model parts for a certain patient by providing an inscription or a label which may not restrict the diagnostic or functional  
10 qualities.

The method can be used in numerous applications.

Thus, it can be usefully applied in combination with the  
15 already applied computer aided surgery simulation, whereby bone segments are cut and moved at a certain angle and over a certain distance. With the help of the method, templates and jigs can be made which provide a perfect reference on the one hand and indicate angles and  
20 movements on the other hand.

The method can also be used for the preparation of tooth implants, whereby the perfected medical model is a template and the functional element is an opening or  
25 notch on the place where drilling is required, or for making a knee prosthesis, whereby the basic model is a metal base which can be joined to a sawn off tibia or femur and whereby the functional elements are orientation pins and/or fastening pins which stand on said base and  
30 which position and/or fix a prosthesis. Also an actual prosthesis can be made according to the method, part of which fits perfectly to existing bone and another part of which forms the functional element with a prosthetic function.

In order to better explain the characteristics of the invention, the following preferred embodiments of a method for making a perfected medical model on the basis of digital image information of a part of the body are given as an example only without being limitative in any way, with reference to the accompanying drawings, in which:

figure 1 shows a general block diagram of a method for making a perfected medical model according to the invention;

figure 2 schematically shows how a perfected medical model is made on the basis of the image;

figure 3 schematically shows how another form of a perfected medical model is made according to the method of the invention;

figures 4 to 8 schematically show how yet other forms of perfected medical models for other applications can be made according to the invention.

As is schematically represented in figure 1, images 3 are made of a part of the body of a patient 1 by means of a computer tomography scanner 2 or any other digital image processing unit such as a Magnetic Resonance Image machine, which thus contain digitized medical information.

Instead of converting these images in for example a three-dimensional image or a dental scan and subsequently either making a model by means of rapid prototyping or processing the images, the image data will be first



processed in a processing unit 4, after which a perfected model 6 is made with these processed digitized image data by means of rapid prototyping with a rapid prototyping machine 5. Use can be made for this operation of a visual three-dimensional image 17 or a dental scan 18 which is derived in the usual manner from the images 3. This three-dimensional image 17 and this dental scan 18 are represented in figure 1 by means of a dashed line.

10 What is characteristic is that the model 6 can be used in reality on the patient 1 or in other words that the cycle represented in figure 1 is completed. In this figure, everything that is situated under the dashed line 19 represents reality, and everything that is situated above it is immaterial information.

The processing or preparation includes the manipulation of medical digital image data, possibly with additional digital information from outside, in such a way that an artificial, functional element 10 with a useful function is added to the produced basic model 9.

The processing of existing and possibly new information or the "design" is carried out with a voxel-oriented system in the processing unit 4, i.e. by means of voxels or contours, whereby voxels or groups of voxels are indicated in the images 3. A voxel is a three-dimensional pixel and thus represents a cube. The grey value data of the voxels can be used to obtain still higher resolutions and accuracies. The processing unit 4 which controls the rapid prototyping machine can help during the processing by carrying out operations on these voxels which are standard operations in three-dimensional image processing, such as thresholding (segmentation on

the basis of grey values), three-dimensional reduction, expansion, region growing, boolean operations such as adding and subtracting, projections, etc.

5 If external technical elements are added, for example coming from a CAD system, these elements must be represented as voxels or contours as well. This can be easily done by means of cross section and shading algorithms.

10

After the interactive processing of the image information (for example rotations, translations, etc.), it is possible to go back to the original CAD data to obtain a higher resolution and accuracy of the functional element.

15

Figure 2 shows an enlarged representation of one of the images 7 with grey values, derived in the processing unit 4 in the form of voxels from the images 3 of a bone 20 produced by the scanner 2. Through processing in the processing unit 4 are made negative images 8 in voxel form which fit perfectly to the images 7 and thus to the bone. Moreover, the image 11 of a functional element 10 is provided in voxel form in the images 8. The images 8 25 coincide with a reference part which forms a negative basic model 9 which fits perfectly to the bone, which basic model 9, together with the functional element 10, forms the perfected model 6.

30 In figure 2 is represented by means of a dashed line 21 the boundary between what is reality (underneath it) and what is image information (above it), whereas what is situated above the dashed line 22 is represented enlarged and in voxel form.

When providing the image 11 of the functional element 10 in voxel form, one can take into account all medical information contained in the images 7. Via stereo lithography, the images 8, with on top of them the images 11 of the functional element 10, are converted in the three-dimensional, factual, perfected model 6 which can be placed as a template on the bone of the patient 1 during a surgery and which fits perfectly to it. The useful function of the functional element 10 can then be put to use. The information of the scanner 2 and the information of the position and direction of the functional element 10 based upon it, are in this way used to the full and translated into reality.

15 In order to pass from the information of the processing unit 4 to the rapid processing technique, one can proceed as follows:

the information or data set, consisting of voxels and contours, of the processing unit 4 is converted into a set of contours per layer height. This is done by means of a screen which is finer than the screen of the original images 3, since the rapid prototyping techniques have a higher resolution than the scanner 2. In order to obtain this finer screen, use is made of the grey value information in the images 3. Thus, a pixel or voxel can partly belong to the perfected model 6 and partly not. This phenomenon is known as partial volume effect. When there are only two materials in one pixel or voxel, a contour line can be calculated in between the pixels by means of interpolation, as described by B. Swaelens and others in "Medical Applications of Rapid Prototyping Techniques", p. 107-120 of "Proceedings of the Fourth International Conference on Rapid Prototyping, Dayton,

OH, June 14-17, 1993". Said higher resolution is important to make the designed model fit well onto the part of the body. Once the contours per layer are calculated, they are interpolated in the third dimension up to the layer height which is suitable for the rapid prototyping technique. This layer height is usually significantly lower than the scan distance.

Another method consists in converting the above-mentioned data set into a surface description with for example one of the usual formats such as triangle format (STL). Such descriptions are used to calculate sections which are made by the rapid prototyping machine 5. Here also, it is possible to work with sub-voxel resolution.

According to a third method, the medical data or digital information is converted from the processing unit 4 to a CAD system. This is again approached by means of a surface description and by calculating the sections. It is possible to further add elements in the CAD system, but not as a function of the image information.

The functional element 10 with a useful function can be a shape, a colour, a texture or another characteristic element. The useful function of the element 10 can be the indication of a place where, a direction in which, a length over which or an angle at which one must cut, saw or drill; it can also be a point of attachment, the filling of an existing defect, a prosthetic function or an identification.

In the embodiment represented in figure 2, the perfected model 6 is a template and the functional element 10 is an opening which indicates the position and direction for

the boring bit of a boring machine. The basic model 9 forms a reference part. The thickness of the basic model 9 at the height of the opening determines the depth of hole.

5

The method can be used for the preparation of tooth implants. The position and the orientation of the implants, both in relation to the bone and in relation to the teeth, is very important. First, a dental scan is made. Thanks to computer-aided preparations, the thickness, position, direction and length of an implant can be well planned. By making a template according to the invention as represented in figure 2, it is not only possible to match the planned size and length of the implant in reality, but also directly the position and direction. For we have a reference part formed by the basic model 9 which fits perfectly to the bone and an element 10 which forms a guide for the boring bit with which the hole for the implant is drilled and which determines the position, direction and depth of said hole.

Instead of directly making a negative perfected model 6, a positive model 13-14 of the bone can be made in the above-described manner, but containing information regarding the position, direction and depth of the drill hole to be made in the form of protrusions 14 as represented in figure 3. Only afterwards, a basic model 9 is made as a reference part, for example manually, with openings as functional elements 10, as a negative mould of the positive model 13-14 as represented in figure 4.

Another application resides in the production of a membrane for bone generation, whereby this membrane can

form the reference part or basic model 9 and the functional element 10 a notch or incision as represented in figure 5. First, a positive intermediate model 15 is made on the basis of the images 3 of the scanner 2, via stereo lithography, consisting of a basic model 9 and the required bone elevation 16 as a first functional element 10. Whereas, according to known methods, said bone elevation is determined by realising the elevation in reality in a radiographically visible material, prior to the scanning, the elevation is calculated according to the invention by the processing unit 4 and imported in the medical information derived from the grey value data, either departing from an ideal bone shape stored in a memory of the processing unit 4 or interactively.

A second functional element 10 can be possibly provided, namely a place indication, for example in the shape of a notch, there where the implant should come. This can be either done through the agency of the user or automatically by means of a computer according to a stored program. In any case, it is preferably provided as a function of the grey value data in a dental scan.

From the intermediate model 15 is made a perfected model 6 in the shape of a membrane by making a mould on the basis of the intermediate model 15 and by shaping a foil in the mould into a membrane. Just as the intermediate model 15, the membrane is provided with a notch as a functional element 10 which has as a function to indicate the place of the implant.

In the case where the implant is provided together with the membrane, reference marks or sutures can be provided as functional elements 10 in the above-described manner

to position the membrane in the space where the bone will grow later.

Another application of the method according to the  
5 invention consists in making prostheses.

With a knee prosthesis, the sliding surface of both the femur and the tibia must be replaced by sawing away a piece and by replacing this piece by a prosthesis.  
10 Hereby, it is important that the prosthesis fits correctly to the bone, especially on the side of the tibia, since there is only a thin wall of strong cortical bone there to support the prosthesis. When the prosthesis is too large, protruding edges form a problem.

15

In the first place, an incision is indicated in voxel form in the images 7, there where the tibia or femur should be sawn. A first negative model 6 is made in the  
20 above-described manners which fits perfectly to the bone 20, but which protrudes all round this bone 20 with an edge which is cut off by said incision. This edge then forms a functional element 10 which serves as a guide for the saw with which the incision is sawn during the  
25 surgery operation.

The voxels above the incision are removed in the processing unit 4 and a base 12 is designed here as a reference part or basic model 9 upon which orientation  
30 pins are provided as functional elements 10 by the processing unit 4. On the basis of this design is made, for example by means of stereo lithography and casting, a real model 6 which fits correctly to the remaining part of the bone 20 and which is provided with functional

elements 10 which are oriented in the right manner.

The base 12 can be designed such that it penetrates partly in the bone 20, and especially also partly surrounds the bone on the outside, as represented in figure 8. This largely increases the strength.

On the basis of the negative model 6 which forms the sawing template, and taking into account the thickness of the base and the position of the functional elements 10, a positive model can be made of the prosthesis itself. One can hereby depart from the real model 6 of the sawing template or preferably from the digital information thereof in the processing unit 4 and calculate the prosthesis with the latter to finally transform it via rapid prototyping in a real prosthesis. This prosthesis will also be provided with functional elements 10 which are complementary to those provided on the base 12.

Instead, a standard prosthesis can be provided on the base 12, whereby the functional elements 10 on the basic model 9 formed by the base 12 need to be provided in this case as a function of complementary elements of the standard prosthesis.

A hip prosthesis can be made in an analogous manner which fits perfectly to the femur shaft on one side and which contains a technical part with functional elements on the other side upon which the artificial femur head can be placed. In the images 7 can be indicated the ideal length and the direction.

A prosthesis fitting perfectly to an existing structure on one side and bearing a technical part on the other



side which has a prosthetic function can also be used for dorsal vertebra. Grey value data, for example regarding the position of the nerves, can be used in the processing unit 4 for the design of the prosthesis.

5

It is also easily possible to design prostheses according to the invention which are partly or entirely supported by weak parts. Such prostheses are for example obstructors or "bobbins" which are used to fill up the nasal cavities and sinuses after tissue and/or bone has been surgically removed. The weak parts can be crushed, and ideally some distance is kept from the bone parts. This is possible according to the invention by slightly enlarging the bone parts in the processing unit 4 at the stage of the image processing. A technical part could possibly be designed as well onto which can be attached a prosthesis such as a dental prosthesis.

10

15

The present invention is by no means limited to the above-described embodiments represented in the drawings; on the contrary, such a method for making a perfected medical model on the basis of digital image information of a part of the body can be made in all sorts of variants while still remaining within the scope of the invention.

20

25

Claims.

- 5 1. Method for making a perfected medical model on the  
basis of digital image information of a part of the body,  
according to which this image information of a part of  
the body is converted, by means of what is called the  
rapid prototyping technique and thus with a processing  
10 unit (4) and a rapid prototyping machine (5), into a  
basic model (9) of which at least a part perfectly shows  
the positive or negative form of at least a part of the  
part of the body, characterized in that at least a  
functional element (10) with a useful function is added  
15 to the basic model (6) as a function of the digital  
information and possibly as a function of additional  
external information.
2. Method according to the preceding claim, characterized  
20 in that the functional element (10) is added as a  
function of the digital image information in the form in  
which all medical data are visible.
3. Method according to any of the preceding claims,  
25 characterized in that the information, on the basis of  
which the functional element (10) is determined, is  
processed factually in the perfected model (6) by means  
of a voxel oriented computer system.
- 30 4. Method according to the preceding claim, characterized  
in that possible new information added from outside to  
determine the functional element (10) is also presented  
as voxels or contours.

5. Method according to any of the preceding claims, characterized in that a functional element (10) is added consisting of a shape, a colour or a texture.

5 6. Method according to any of the preceding claims, characterized in that a functional element (10) is added whose useful function can be the indication of a position, a direction, a length or an angle which are important during a surgery, the formation of a point of attachment, the formation of a filling for a certain defect, a prosthetic function or an identification.

10 7. Method according to claim 6, characterized in that a drilling or sawing template is made with a reference part as a basic model (9) which fits perfectly to a part of the body part and a guide for the instrument as a functional element (10).

15 8. Method according to claim 6, characterized in that it is used for the preparation of tooth implants and in that a basic model (9) is made with a reference part and at least one functional element (10) via a dental scan (18) and simulation in different planes.

20 9. Method according to claim 6, characterized in that a membrane for bone generation is formed and an intermediate model (15) is made first consisting of a basic model (9) with a required bone elevation (16) as a functional element (10), determined by means of the grey value images (7), after which, by means of a mould, a metal foil is transformed into a membrane containing the above-mentioned functional element (10).

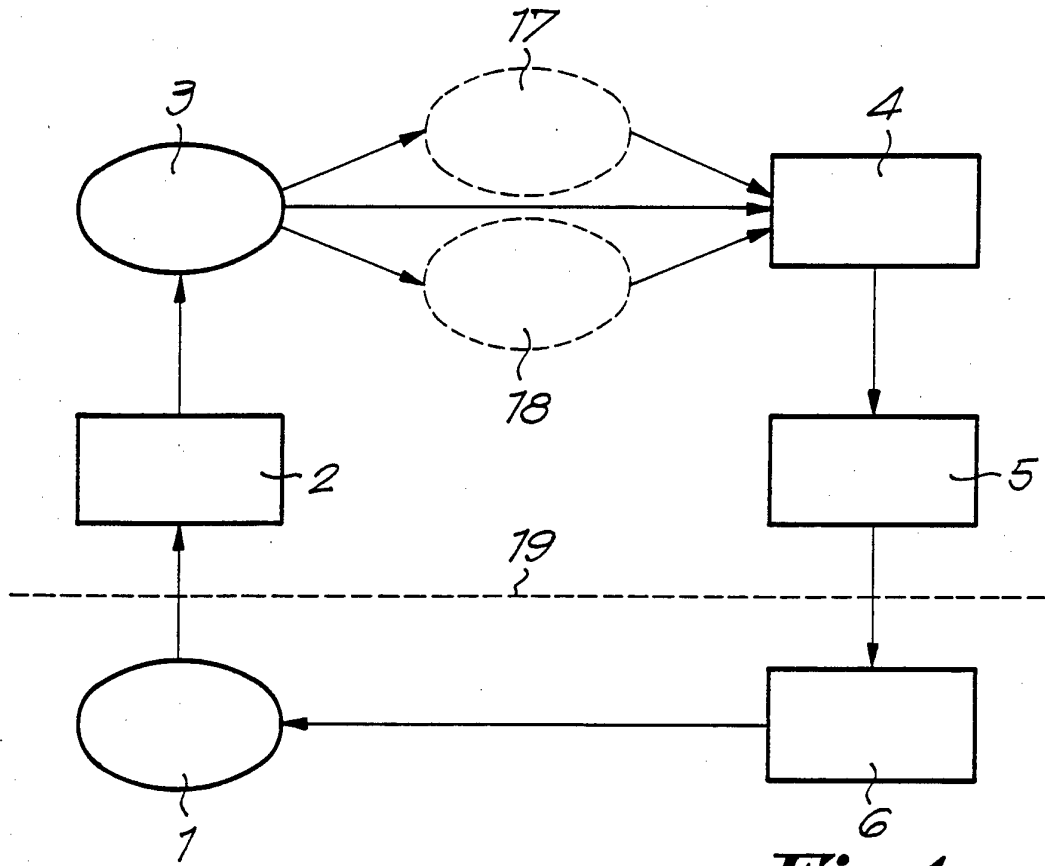
25 10. Method according to any of claims 8 and 9,

characterized in that a membrane for bone generation is formed and an intermediate model (15) is made first consisting of a basic model (9) with a notch or an incision as a functional element (10) to indicate the place of an implant, after which, by means of a mould, a metal foil is transformed into a membrane containing the above-mentioned functional element (10).

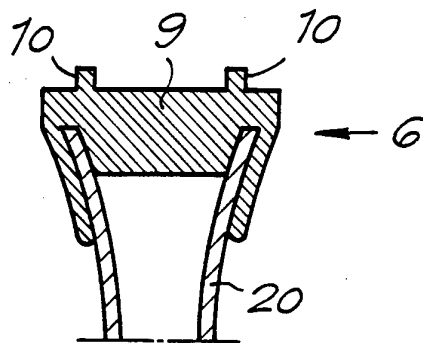
11. Method according to claim 6, characterized in that a perfected model (6) is made by first making a positive model (13-14) of the structure containing information on a functional element (10) and by subsequently making a negative mould of it.

12. Method according to claim 6, characterized in that on the basis of the information of a bone (20) sawn off on one side, by means of the processing unit (4) and a rapid prototyping machine (5), is made a base (12) as basic model (9) which is provided with fastening pins and/or orientation pins as functional elements (10) to position a prosthesis.

13. Method according to claim 6, characterized in that a prosthesis is made supported by weak parts surrounding a bone (20), whereby a perfected model (6) is made on the basis of the digital image information by slightly enlarging the bone parts in the processing unit (4) at the stage of the image processing.

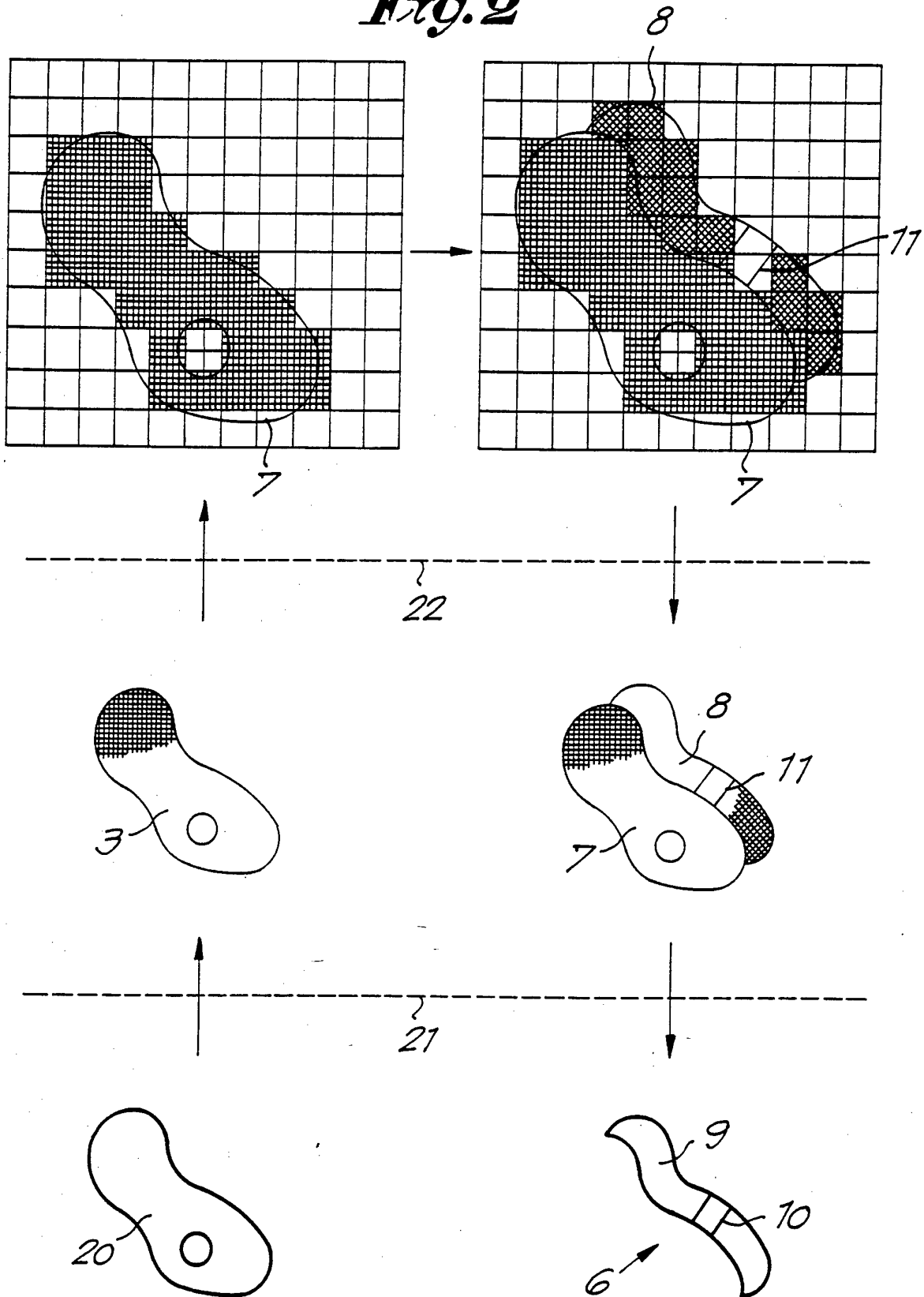


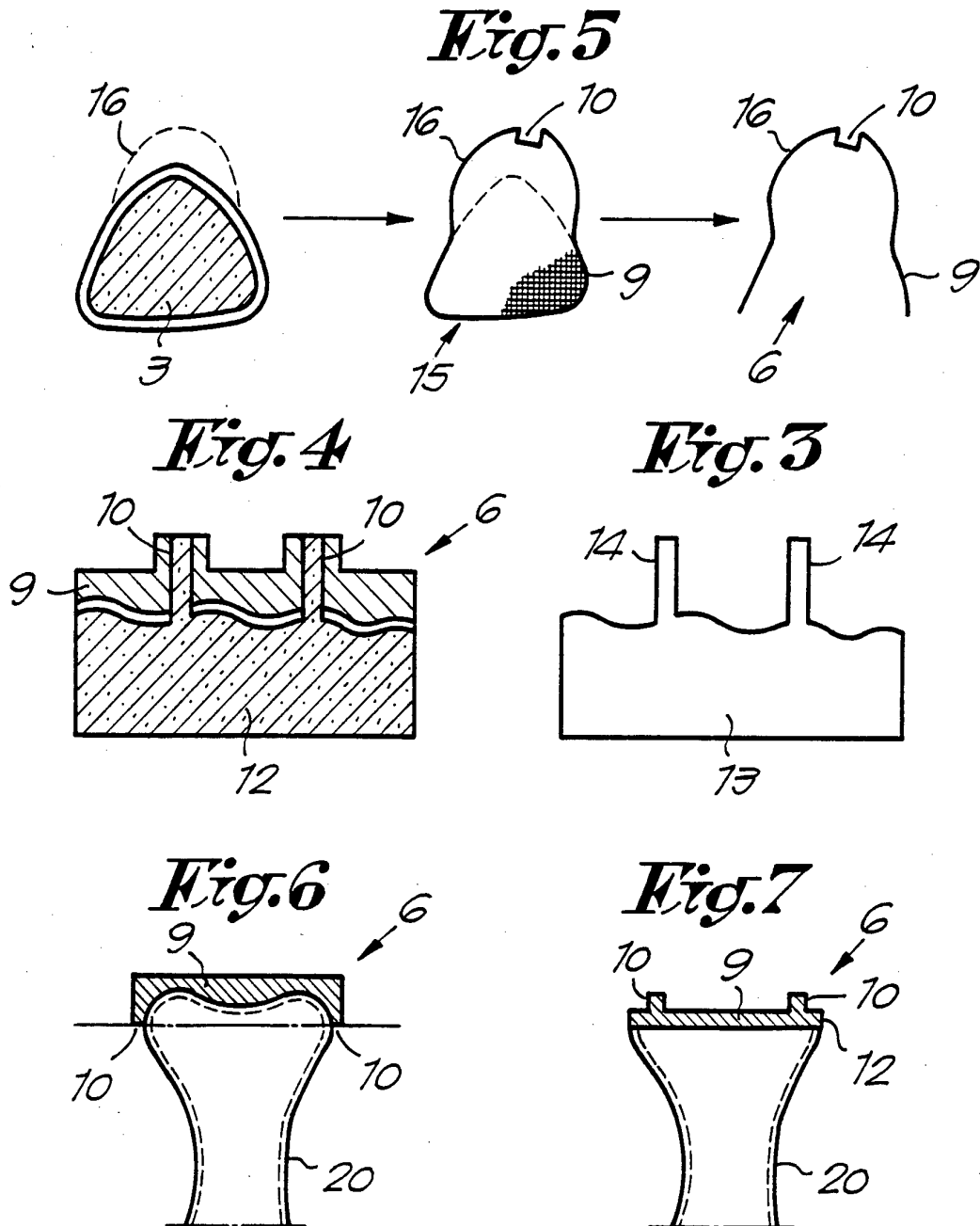
*Fig. 1*



*Fig. 8*

*Fig. 2*





INTERNATIONAL SEARCH REPORT

International Application No

PCT/BE 95/00033

A. CLASSIFICATION OF SUBJECT MATTER  
IPC 6 G06T15/00

According to International Patent Classification (IPC) or to both national classification and IPC

B. FIELDS SEARCHED

Minimum documentation searched (classification system followed by classification symbols)  
IPC 6 G06T

Documentation searched other than minimum documentation to the extent that such documents are included in the fields searched

Electronic data base consulted during the international search (name of data base and, where practical, search terms used)

C. DOCUMENTS CONSIDERED TO BE RELEVANT

Category *	Citation of document, with indication, where appropriate, of the relevant passages	Relevant to claim No.
X	AUSTRALASIAN PHYSICAL & ENGINEERING SCIENCES IN MEDICINE, vol. 16, no. 2, June 1993 AUSTRALIA, pages 79-85, BARKER E.A. 'INTEGRATION OF 3-D MEDICAL IMAGING AND RAPID PROTOTYPING TO CREATE STEREOLITOGRAPHIC MODELS' see the whole document	1-13
X	EP-A-0 535 984 (SPECTRA GROUP) 7 April 1993 see the whole document	1,2,5

Further documents are listed in the continuation of box C.

Patent family members are listed in annex.

\* Special categories of cited documents :

- 'A' document defining the general state of the art which is not considered to be of particular relevance
- 'E' earlier document but published on or after the international filing date
- 'I' document which may throw doubts on priority claim(s) or which is cited to establish the publication date of another citation or other special reason (as specified)
- 'O' document referring to an oral disclosure, use, exhibition or other means
- 'P' document published prior to the international filing date but later than the priority date claimed

- 'T' later document published after the international filing date or priority date and not in conflict with the application but cited to understand the principle or theory underlying the invention
- 'X' document of particular relevance; the claimed invention cannot be considered novel or cannot be considered to involve an inventive step when the document is taken alone
- 'Y' document of particular relevance; the claimed invention cannot be considered to involve an inventive step when the document is combined with one or more other such documents, such combination being obvious to a person skilled in the art.
- '&' document member of the same patent family

Date of the actual completion of the international search

29 June 1995

Date of mailing of the international search report

18.07.95

Name and mailing address of the ISA

European Patent Office, P.B. 5818 Patentlaan 2  
NL - 2280 HV Rijswijk  
Tel. (+ 31-70) 340-2040, Tx. 31 651 epo nl,  
Fax: (+ 31-70) 340-3016

Authorized officer

Burgaud, C



# INTERNATIONAL SEARCH REPORT

Information on patent family members

International Application No

PCT/BE 95/00033

Patent document cited in search report	Publication date	Patent family member(s)	Publication date
EP-A-0535984	07-04-93	JP-A- 5212806	24-08-93