



- (51) International Patent Classification:  
A61B 19/00 (2006.01) A61B 18/00 (2006.01)
- (71) International Application Number:  
PCT/US2013/040786
- (22) International Filing Date:  
13 May 2013 (13.05.2013)
- (25) Filing Language: English
- (26) Publication Language: English
- (30) Priority Data:  
61/646,643 14 May 2012 (14.05.2012) US
- (71) Applicant: INTUITIVE SURGICAL OPERATIONS [US/US]; 1266 Kifer Road, Building 101, Sunnyvale, California 94086 (US).
- (72) Inventor: CHOPRA, Prashant; 870 East El Camino Real, Sunnyvale, California 94087 (US).
- (74) Agents: NICKOLS, Julie et al.; Intuitive Surgical Operations, 1266 Kifer Road, Bldg. 101, Sunnyvale, California 94086 (US).
- (81) Designated States (unless otherwise indicated, for every kind of national protection available): AE, AG, AL, AM,

AO, AT, AU, AZ, BA, BB, BG, BH, BN, BR, BW, BY, BZ, CA, CH, CL, CN, CO, CR, CU, CZ, DE, DK, DM, DO, DZ, EC, EE, EG, ES, FI, GB, GD, GE, GH, GM, GT, HN, HR, HU, ID, IL, IN, IS, JP, KE, KG, KM, KN, KP, KR, KZ, LA, LC, LK, LR, LS, LT, LU, LY, MA, MD, ME, MG, MK, MN, MW, MX, MY, MZ, NA, NG, NI, NO, NZ, OM, PA, PE, PG, PH, PL, PT, QA, RO, RS, RU, RW, SC, SD, SE, SG, SK, SL, SM, ST, SV, SY, TH, TJ, TM, TN, TR, TT, TZ, UA, UG, US, UZ, VC, VN, ZA, ZM, ZW.

- (84) Designated States (unless otherwise indicated, for every kind of regional protection available): ARIPO (BW, GH, GM, KE, LR, LS, MW, MZ, NA, RW, SD, SL, SZ, TZ, UG, ZM, ZW), Eurasian (AM, AZ, BY, KG, KZ, RU, TJ, TM), European (AL, AT, BE, BG, CH, CY, CZ, DE, DK, EE, ES, FI, FR, GB, GR, HR, HU, IE, IS, IT, LT, LU, LV, MC, MK, MT, NL, NO, PL, PT, RO, RS, SE, SI, SK, SM, TR), OAPI (BF, BJ, CF, CG, CI, CM, GA, GN, GQ, GW, ML, MR, NE, SN, TD, TG).

**Published:**

— with international search report (Art. 21(3))

(54) Title: SYSTEMS AND METHODS FOR REGISTRATION OF A MEDICAL DEVICE USING RAPID POSE SEARCH

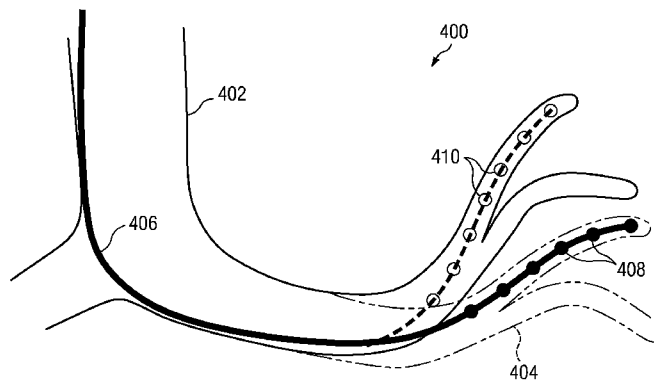

Fig. 6

(57) Abstract: A method comprises identifying linked anatomical structures in stored images of a patient anatomy and modeling a structure of linkage elements. Each linkage element corresponds to one of the linked anatomical structures. The method also includes modeling a portion of the patient anatomy as a plurality of search slabs and assigning each of the linkage elements to one of the plurality of search slabs. The method also includes receiving tracking data corresponding to a sensed instrument portion. The tracking data includes position information and orientation information for the sensed instrument portion. The method also includes identifying one of the plurality of search slabs which includes the position information for the sensed instrument portion and matching the sensed instrument portion to a matched linkage element from among the linkage elements assigned to the identified one of the plurality of search slabs.



**SYSTEMS AND METHODS FOR REGISTRATION OF  
A MEDICAL DEVICE USING RAPID POSE SEARCH**

**FIELD**

5           The present disclosure is directed to systems and methods for tracking a medical device within a patient anatomy during a medical procedure, and more particularly to systems and methods for tracking a medical device within a patient anatomy using a modeled structure of the patient anatomy to conduct a rapid pose search.

**BACKGROUND**

10           Minimally invasive medical techniques are intended to reduce the amount of tissue that is damaged during diagnostic or surgical procedures, thereby reducing patient recovery time, discomfort, and deleterious side effects. Such minimally invasive techniques may be performed through natural orifices in a patient anatomy or through one or more surgical incisions. Through these natural orifices or incisions clinicians may insert surgical  
15 instruments to reach a target tissue location. To reach the target tissue location, the minimally invasive surgical instruments may navigate natural or surgically created connected passageways in anatomical systems such as the lungs, the colon, the intestines, the kidneys, the heart, the circulatory system, or the like. Navigational assist systems help the clinician route the surgical instruments and avoid damage to the anatomy. These systems can  
20 incorporate the use of position and shape sensors to more accurately describe the shape, pose, and location of the surgical instrument in real space or with respect to pre-procedural or concurrent images. In a dynamic anatomical system and/or in an anatomical region dense with many anatomical passageways, accurately registering a minimally invasive instrument to the anatomical system is a time consuming and computer processing intensive task.  
25 Improved systems and methods are needed for increasing the accuracy and efficiency of systems and methods of registering minimally invasive instruments to the anatomical system.

30

## SUMMARY

The embodiments of the disclosure are summarized by the claims that follow below.

In one embodiment, a method comprises identifying linked anatomical structures in stored images of a patient anatomy and modeling a structure of linkage elements. Each linkage element corresponds to one of the linked anatomical structures. The method also includes modeling a portion of the patient anatomy as a plurality of search slabs and assigning each of the linkage elements to one of the plurality of search slabs. The method also includes receiving tracking data corresponding to a sensed instrument portion. The tracking data includes position information and orientation information for the sensed instrument portion. The method also includes identifying one of the plurality of search slabs which includes the position information for the sensed instrument portion and matching the sensed instrument portion to a matched linkage element from among the linkage elements assigned to the identified one of the plurality of search slabs.

In another embodiment, a medical system comprises a memory storing images of a patient anatomy. The system further includes a processor for identifying linked anatomical structures in the stored images of a patient anatomy. The processor also receives the tracking data which includes position information and orientation information for a sensed instrument portion. The processor also modifies the tracking data to generate snapped position and snapped orientation information for the sensed instrument portion and renders a composite medical image. The composite medical image includes an image of at least a portion of the linked anatomical structures and an image of the sensed instrument portion in the snapped position and snapped orientation.

In another embodiment, a method comprises rendering a composite medical image that includes an image of a plurality of passageways in a patient anatomy and an image of a medical instrument. The method also includes correcting the image of the medical instrument to position a point on the medical instrument within one of the plurality of passageways in the composite medical image. The image is corrected by generating a model of the passageways, identifying one of a plurality of slabs of the model that includes a position of the medical instrument, and matching one of the passageways in the slab to the point on the medical instrument.

### BRIEF DESCRIPTIONS OF THE DRAWINGS

Aspects of the present disclosure are best understood from the following detailed description when read with the accompanying figures. It is emphasized that, in accordance with the standard practice in the industry, various features are not drawn to scale. In fact, the dimensions of the various features may be arbitrarily increased or reduced for clarity of discussion. In addition, the present disclosure may repeat reference numerals and/or letters in the various examples. This repetition is for the purpose of simplicity and clarity and does not in itself dictate a relationship between the various embodiments and/or configurations discussed.

10 Fig. 1 is a robotic surgical system, in accordance with embodiments of the present disclosure.

Fig. 2 illustrates a surgical instrument system utilizing aspects of the present disclosure.

15 Fig. 3a is an image of a human lung registered with an image of a minimally invasive instrument.

Fig. 3b is an internal image of the human lung depicting the region of the human lung from the viewpoint of the minimally invasive instrument.

Figs. 4a - 4d depict a method of registering a portion of a minimally invasive instrument to a set of linked elements corresponding to passageways of a patient anatomy.

20 Fig 5 is a flowchart depicting the method according to an embodiment of this disclosure.

Fig. 6 illustrates an image of a portion of a set of anatomical passageways with an image of a measured device shape and a snapped device shape.

25

## DETAILED DESCRIPTION

In the following detailed description of the embodiments of the invention, numerous specific details are set forth in order to provide a thorough understanding of the disclosed embodiments. However, it will be obvious to one skilled in the art that the embodiments of this disclosure may be practiced without these specific details. In other instances well known methods, procedures, components, and circuits have not been described in detail so as not to unnecessarily obscure aspects of the embodiments of the invention.

The embodiments below will describe various instruments and portions of instruments in terms of their state in three-dimensional space. As used herein, the term “position” refers to the location of an object or a portion of an object in a three-dimensional space (e.g., three degrees of translational freedom along Cartesian X,Y,Z coordinates). As used herein, the term “orientation” refers to the rotational placement of an object or a portion of an object (three degrees of rotational freedom – e.g., roll, pitch, and yaw). As used herein, the term “pose” refers to the position of an object or a portion of an object in at least one degree of translational freedom and to the orientation of that object or portion of the object in at least one degree of rotational freedom (up to six total degrees of freedom). As used herein, the term “shape” refers to a set of poses, positions, or orientations measured along an object.

Referring to FIG. 1 of the drawings, a robotic surgical system is generally indicated by the reference numeral 100. As shown in FIG. 1, the robotic system 100 generally includes a surgical manipulator assembly 102 for operating a surgical instrument 104 in performing various procedures on the patient P. The assembly 102 is mounted to or near an operating table O. A master assembly 106 allows the surgeon S to view the surgical site and to control the manipulator assembly 102.

In alternative embodiments, the robotic system may include more than one manipulator assembly. The exact number of manipulator assemblies will depend on the surgical procedure and the space constraints within the operating room among other factors.

The master assembly 106 may be located at a surgeon's console C which is usually located in the same room as operating table O. However, it should be understood that the surgeon S can be located in a different room or a completely different building from the patient P. Master assembly 106 generally includes an optional support 108 and one or more control device(s) 112 for controlling the manipulator assemblies 102. The control device(s) 112 may include any number of a variety of input devices, such as joysticks, trackballs, gloves, trigger-guns, hand-operated controllers, voice recognition devices or the like. In some

embodiments, the control device(s) 112 will be provided with the same degrees of freedom as the associated surgical instruments 104 to provide the surgeon with telepresence, or the perception that the control device(s) 112 are integral with the instruments 104 so that the surgeon has a strong sense of directly controlling instruments 104. In some embodiments, the control devices 112 are manual input devices which move with six degrees of freedom, and which may also include an actuatable handle for actuating instruments (for example, for closing grasping jaws, applying an electrical potential to an electrode, delivering a medicinal treatment, or the like).

A visualization system 110 may include a viewing scope assembly (described in greater detail below) such that a concurrent or real-time image of the surgical site is provided to surgeon console C. The concurrent image may be, for example, a two or three dimensional image captured by an endoscope positioned within the surgical site. In this embodiment, the visualization system 100 includes endoscopic components that may be integrally or removably coupled to the surgical instrument 104. However in alternative embodiments, a separate endoscope, attached to a separate manipulator assembly may be used with the surgical instrument to image the surgical site. The visualization system 110 may be implemented as hardware, firmware, software or a combination thereof which interact with or are otherwise executed by one or more computer processors, which may include the processors of a control system 116 (described below).

A display system 111 may display an image of the surgical site and surgical instruments captured by the visualization system 110. The display 111 and the master control devices 112 may be oriented such that the relative positions of the imaging device in the scope assembly and the surgical instruments are similar to the relative positions of the surgeon's eyes and hands so the operator can manipulate the surgical instrument 104 and the hand control as if viewing the workspace in substantially true presence. By true presence, it is meant that the presentation of an image is a true perspective image simulating the viewpoint of an operator that is physically manipulating the surgical instruments 104.

Alternatively or additionally, monitor 111 may present images of the surgical site recorded and/or modeled preoperatively using imaging technology such as, computerized tomography (CT), magnetic resonance imaging (MRI), fluoroscopy, thermography, ultrasound, optical coherence tomography (OCT), thermal imaging, impedance imaging, laser imaging, or nanotube X-ray imaging. The presented preoperative images may include two-dimensional, three-dimensional, or four-dimensional images.

In some embodiments, the monitor 111 may display a virtual navigational image in which the actual location of the surgical instrument is registered (i.e., dynamically referenced) with preoperative or concurrent images to present the surgeon S with a virtual image of the internal surgical site at the location of the tip of the surgical instrument. An image of the tip of the surgical instrument or other graphical or alphanumeric indicators may be superimposed on the virtual image to assist the surgeon controlling the surgical instrument. Alternatively, the surgical instrument may not be visible in the virtual image.

In other embodiments, the monitor 111 may display a virtual navigational image in which the actual location of the surgical instrument is registered with preoperative or concurrent images to present the surgeon S with a virtual image of surgical instrument within the surgical site from an external viewpoint. An image of a portion of the surgical instrument or other graphical or alphanumeric indicators may be superimposed on the virtual image to assist the surgeon controlling the surgical instrument.

As shown in FIG. 1, a control system 116 includes at least one processor and typically a plurality of processors for effecting control between the surgical manipulator assembly 102, the master assembly 106, and the image and display system 110. The control system 116 also includes software programming instructions to implement some or all of the methods described herein. While control system 116 is shown as a single block in the simplified schematic of Fig. 1, the system may comprise a number of data processing circuits (e.g., on the surgical manipulator assembly 102 and/or on the master assembly 106), with at least a portion of the processing optionally being performed adjacent an input device, a portion being performed adjacent a manipulator, and the like. Any of a wide variety of centralized or distributed data processing architectures may be employed. Similarly, the programming code may be implemented as a number of separate programs or subroutines, or may be integrated into a number of other aspects of the robotic systems described herein. In one embodiment, control system 116 may support wireless communication protocols such as Bluetooth, IrDA, HomeRF, IEEE 802.11, DECT, and Wireless Telemetry.

In some embodiments, control system 116 may include servo controllers to provide force and torque feedback from the surgical instruments 104 to the hand-operated control device 112. Any suitable conventional or specialized servo controller may be used. A servo controller may be separate from, or integral with manipulator assemblies 102. In some embodiments, the servo controller and manipulator assembly are provided as part of a robotic arm cart positioned adjacent to the patient's body. The servo controller transmits signals

instructing the manipulator assemblies to move instruments which extend into an internal surgical site within the patient body via openings in the body.

Each of the manipulator assemblies 102 that support a surgical instrument 104 and may comprise a series of manually articulatable linkages, generally referred to as set-up joints, and a robotic manipulator. The robotic manipulator assemblies 102 may be driven by a series of actuators (e.g., motors). These motors actively move the robotic manipulators in response to commands from the control system 116. The motors are further coupled to the surgical instrument so as to advance the surgical instrument into a naturally or surgically created anatomical orifice and to move the distal end of the surgical instrument in multiple degrees of freedom that may include three degrees of linear motion (e.g., X,Y, Z linear motion) and three degrees of rotational motion (e.g., roll, pitch, yaw). Additionally, the motors can be used to actuate an articulatable end effector of the instrument for grasping tissues in the jaws of a biopsy device or the like.

Fig. 2 illustrates a tracked instrument system 118 which includes the surgical instrument system 104 and its interfacing systems. The surgical instrument system 104 includes a flexible instrument 120 coupled by an interface 122 to manipulator assembly 102 and visualization system 110. The instrument 120 has a flexible body 124, a tip 126 at its distal end 128, and the interface 122 at its proximal end 130. The body 124 houses cables, linkages, or other steering controls (not shown) that extend between the interface 122 and the tip 126 to controllably bend or turn the tip as shown for example by the dotted line versions of the bent tip 126, and in some embodiments control an optional end effector 132. The flexible instrument may be steerable, including the steering controls previously described, or may be non-steerable with no integrated mechanism for operator control of the instrument bending. The end effector may be a working distal part that is manipulable for a medical function, e.g., for effecting a predetermined treatment of a target tissue. For instance, some end effectors have a single working member such as a scalpel, a blade, or an electrode. Other end effectors such as shown in the embodiment of Fig. 2, have a pair or plurality of working members such as forceps, graspers, scissors, or clip applicators, for example. Examples of electrically activated end effectors include electrosurgical electrodes, transducers, sensors, and the like. End effectors may also include conduits to convey fluids, gases or solids to perform, for example, suction, insufflation, irrigation, treatments requiring fluid delivery, accessory introduction, biopsy extraction and the like). In other embodiments, flexible body 124 can define one or more lumens through which surgical instruments can be deployed and



used at a target surgical location.

The instrument 120 can also include an image capture element 134 which may include a stereoscopic or monoscopic camera disposed at the distal end 128 for capturing images that are transmitted to and processed by the visualization system 110 for display by the display system 111. Alternatively, the image capture element 134 may be a coherent fiber-optic bundle that couples to an imaging and processing system on the proximal end of the instrument 120, such as a fiberscope. The image capture element 134 may be single or multi-spectral for capturing image data in the visible or infrared/ ultraviolet spectrum.

A tracking system 135 includes an electromagnetic (EM) sensor system 136 and a shape sensor system 138 for determining the position, orientation, speed, pose, and/or shape of the distal end 128 and of one or more segments 137 along the instrument 120. Although only an exemplary set of segments 137 are depicted in Fig. 2, the entire length of the instrument 120, between the distal end 128 and the proximal end 130 and including the tip 126 may be effectively divided into segments. The tracking system 135 may be implemented as hardware, firmware, software or a combination thereof which interact with or are otherwise executed by one or more computer processors, which may include the processors of a control system 116.

The EM sensor system 136 includes one or more conductive coils that may be subjected to an externally generated electromagnetic field. Each coil of the EM sensor system 136 then produces an induced electrical signal having characteristics that depend on the position and orientation of the coil relative to the externally generated electromagnetic field. In one embodiment, the EM sensor system may be configured and positioned to measure six degrees of freedom, e.g., three position coordinates X, Y, Z and three orientation angles indicating pitch, yaw, and roll of a base point. Further description of an EM sensor system is provided in U.S. Pat. No. 6,380,732, filed August 11, 1999, disclosing "Six-Degree of Freedom Tracking System Having a Passive Transponder on the Object Being Tracked," which is incorporated by reference herein in its entirety.

The sensor system 138 includes an optical fiber 140 aligned with the flexible body 124 (e.g., provided within an interior channel (not shown) or mounted externally). The tracking system 135 is coupled to a proximal end of the optical fiber 140. In this embodiment, the fiber 140 has a diameter of approximately 200  $\mu\text{m}$ . In other embodiments, the dimensions may be larger or smaller.

The optical fiber 140 forms a fiber optic bend sensor for determining the shape of the

instrument 120. In one alternative, optical fibers including Fiber Bragg Gratings (FBGs) are used to provide strain measurements in structures in one or more dimensions. Various systems and methods for monitoring the shape and relative position of an optical fiber in three dimensions are described in U.S. Pat. App. No. 11/180,389, filed July, 13, 2005, disclosing  
5 “Fiber optic position and shape sensing device and method relating thereto;” U.S. Provisional Pat. App. No. 60/588,336, filed on Jul. 16, 2004, disclosing “Fiber-optic shape and relative position sensing;” and U.S. Pat. No. 6,389,187, filed on Jun. 17, 1998, disclosing “Optical Fibre Bend Sensor,” which are incorporated by reference herein in their entireties. In other alternative embodiments, the shape of the instrument 120 may be determined using other  
10 techniques. For example, if the history of instrument tip’s pose is stored for an interval of time that is smaller than the period for refreshing the navigation display or for alternating motion (e.g., inhalation and exhalation), the pose history can be used to reconstruct the shape of the device over the interval of time. As another example, historical pose, position, or orientation data may be stored for a known point of an instrument along a cycle of alternating  
15 motion, such as breathing. This stored data may be used to develop shape information about the instrument. Alternatively, a series of positional sensors, such as EM sensors, positioned along the instrument can be used for shape sensing. Alternatively, a history of data from a positional sensor, such as an EM sensor, on the instrument during a procedure may be used to represent the shape of the instrument, particularly if an anatomical passageway is generally  
20 static. Alternatively, a wireless device with position or orientation controlled by an external magnetic field may be used for shape sensing. The history of its position may be used to determine a shape for the navigated passageways.

In this embodiment, the optical fiber 140 may include multiple cores within a single cladding 146. Each core may be single-mode with sufficient distance and cladding separating  
25 the cores such that the light in each core does not interact significantly with the light carried in other cores. In other embodiments, the number of cores may vary or each core may be contained in a separate optical fiber.

In some embodiments, an array of FBG’s is provided within each core. Each FBG comprises a series of modulations of the core’s refractive index so as to generate a spatial  
30 periodicity in the refraction index. The spacing may be chosen so that the partial reflections from each index change add coherently for a narrow band of wavelengths, and therefore reflect only this narrow band of wavelengths while passing through a much broader band. During fabrication of the FBG’s, the modulations are spaced by a known distance, thereby

causing reflection of a known band of wavelengths. However, when a strain is induced on the fiber core, the spacing of the modulations will change, depending on the amount of strain in the core. Alternatively, backscatter or other optical phenomena that vary with bending of the optical fiber can be used to determine strain within each core.

5 Thus, to measure strain, light is sent down the fiber, and characteristics of the returning light are measured. For example, FBG's produce a reflected wavelength that is a function of the strain on the fiber and its temperature. This FBG technology is commercially available from a variety of sources, such as Smart Fibres Ltd. of Bracknell, England. Use of FBG technology in position sensors for robotic surgery is described in U.S. Pat. No.  
10 7,930,065, filed July 20, 2006, disclosing "Robotic Surgery System Including Position Sensors Using Fiber Bragg Gratings," which is incorporated by reference herein in its entirety.

When applied to a multicore fiber, bending of the optical fiber induces strain on the cores that can be measured by monitoring the wavelength shifts in each core. By having two  
15 or more cores disposed off-axis in the fiber, bending of the fiber induces different strains on each of the cores. These strains are a function of the local degree of bending of the fiber. For example, regions of the cores containing FBG's, if located at points where the fiber is bent, can thereby be used to determine the amount of bending at those points. These data, combined with the known spacings of the FBG regions, can be used to reconstruct the shape  
20 of the fiber. Such a system has been described by Luna Innovations. Inc. of Blacksburg, Va.

As described, the optical fiber 140 is used to monitor the shape of at least a portion (the sensed instrument portion) of the instrument 120. More specifically, light passing through the optical fiber 140 is processed by the tracking system 135 for detecting the shape of the sensed instrument portion of the surgical instrument 120 and for utilizing that  
25 information to assist in surgical procedures. The tracking system 135 may include a detection system for generating and detecting the light used for determining the shape of the sensed instrument portion of the surgical instrument 120. This information, in turn, in can be used to determine other related variables, such as velocity and acceleration of the parts of a surgical instrument. By obtaining accurate measurements of one or more of these variables in real  
30 time, the controller can improve the accuracy of the robotic surgical system and compensate for errors introduced in driving the component parts. The sensing may be limited only to the degrees of freedom that are actuated by the robotic system, or may be applied to both passive (e.g., unactuated bending of the rigid members between joints) and active (e.g., actuated

movement of the instrument) degrees of freedom.

The information from the tracking system 135 may be sent to the navigation system 142 where it is combined with information from the visualization system 110 and/or the preoperatively taken images to provide the surgeon or other operator with real-time position information on the display system 111 for use in the control of the instrument 120. The control system 116 may utilize the position information as feedback for positioning the instrument 120. Various systems for using fiber optic sensors to register and display a surgical instrument with surgical images are provided in U.S. Patent Application No. 13/107,562, filed May 13, 2011, disclosing, "Medical System Providing Dynamic Registration of a Model of an Anatomical Structure for Image-Guided Surgery," which is incorporated by reference herein in its entirety.

In the embodiment of Fig. 2, the instrument 104 is teleoperated within the robotic surgical system 100. In an alternative embodiment, the manipulator assembly may be replaced by direct operator control. In the direct operation alternative, various handles and operator interfaces may be included for hand-held operation of the instrument.

Fig. 3a depicts a composite image 150 including an image 151 of a human lung 152, from a viewpoint external to the lung, registered with an instrument image 154 of a flexible instrument, such as the flexible instrument 120. The image 151 of the lung 152 may be generated from preoperatively recorded images or may be generated concurrently during the surgical procedure. The composite image 150 may be displayed via display system 111. As the instrument 120 is advanced through bronchial passageways 156 of the lung 152, information from the tracking system 135 and/or the visualization system 110 are used to register the instrument image 154 with the lung image 151. The image 151 of the lung 152 may change, for example, to depict the lung in a state of inspiration or expiration. The instrument image 154 may change to depict the advancement or withdrawal of the instrument 120 through the bronchial passageways 156. Occasionally, the composite image 150 may erroneously render the instrument image 154 such that a portion of the instrument image 154' is outside of a bronchial passageway. Systems and methods are described below for correcting the instrument image such that the instrument is located within the bronchial passageways.

Fig. 3b depicts an internal image 160 of the human lung 152 depicting a region of the lung from the viewpoint of the instrument 120. The image 160 may be a concurrent image taken during the surgical procedure by the instrument 120 while located in the depicted

portion of the lung 152. More specifically, the image may be captured by the visualization system 110. Alternatively, the image 160 may be a preoperatively recorded image selected based upon the location of the tip of the instrument 120 as determined by the tracking system 135.

5 Figs. 4a-4d depict a method of registering a point on a minimally invasive instrument, such as the flexible instrument 120, to a set of linked elements corresponding to passageways of a patient anatomy. Fig 5. is a flowchart 300 describing the method depicted in Figs. 4a-4d. Often, the tracking system 135, which includes the EM sensor system 136 and the shape sensor system 138 may calculate a position for the instrument tip 126 or one or more  
10 segments 137 of the instrument 120 that is outside the anatomical passageway if depicted in a composite image. This likely indicates a slight measurement error (assuming the wall of the anatomical passageway has not been breached). Such an error may result from the dynamic nature of certain anatomic structures such as the lungs or the heart. For example, inhalation and exhalation changes the position and size of the bronchial passageways of the lung.  
15 Alternatively, the error may result from tissue deformation caused by the presence of the surgical instrument within the anatomic passageways.

To correct the position of the instrument and accurately locate one or more points of the instrument within the passageway when the image of the instrument and the image of the patient anatomy are co-registered and displayed, selected points of the instrument may be  
20 graphically registered to a location on the wall of the anatomical passageway or to the lumen of the anatomical passageway (i.e., snapped). Fig. 6 illustrates a general snapping operation. A set of anatomical passageways 400 (e.g., bronchial passageways) is illustrated. The solid line 402 is an image of a static passageway generated by a preoperative image (or generated by another preoperative or standard anatomical dataset). The passageway as deformed by an  
25 instrument 406 is represented by dashed line 404. The actual sensed instrument shape 408 causing the deformed passageway 404 is represented by a trail of solid dots. The instrument shape 408 is the sensed instrument shape prior to any snapping adjustments. The snapped instrument shape 410 is represented by a trail of open dots. As will be described in detail below, systems and methods are provided to adjust the pose, position, or orientation of the  
30 sensed instrument shape 408 into the snapped instrument shape 410 that conforms with the shape of the preoperative image.

Methods for determining the proper location to which a point of an instrument should be snapped are described in detail below but generally include identifying linked anatomical

structures in stored images of a patient anatomy and then modeling a structure of linkage elements with each linkage element corresponding to one of the linked anatomical structures.

With the flexible instrument inserted into the linked anatomical structures, tracking data is received from the instrument. The tracking data includes position information and orientation information for one or more portions of the instrument. The tracking data is modified to generate snapped position and snapped orientation information for the sensed instrument portions. A composite medical image is then rendered to include an image of some portion of the linked anatomical structures and an image of the sensed instrument portion in the snapped position and snapped orientation.

In Fig. 4a and at step 302, a branched structure 200 of linked elements P1-P7 is modeled from preoperative images of a patient anatomy. The images may be, for example, CT images of the lung 152. The linked elements P1-P7 may correspond generally to branch points in the airway passages of the lung 152. The branched structure 200 also includes linkages 202, extending between the linked elements P1-P7, which generally correspond the bronchial passageways between the branch points in the lung 152. Initially, there may be no order associated with the linked elements P1-P7 other than the order provided by the branched structure 200. The branched structure 200 may be retained in a computer memory and optionally may be depicted on a display.

In Fig. 4b, and at step 304, the linked elements P1-P7 are sorted according to their location along a chosen axis which can be one of the three orthogonal axes spanning the patient image volume (X, Y, or Z). For example, the chosen axis may be a Z coordinate axis, e.g., an axis that corresponds generally to a caudal-cranio axis of the patient anatomy. Alternatively, the axis may be an oblique axis aligned with anatomical features such as a medial line of a large organ. In another alternative embodiment, the axis may be an axis aligned with the general direction of the planned surgical path through the anatomy.

A registry of the sorted linked elements P1-P7 may be generated and stored. For example, the order of linked elements P1-P7 according to their location along the Z axis is P6, P4, P2, P7, P3, P1, and P5. Based upon this ordering, the linked elements P1-P7 are assigned to search slabs, i.e., regions of points within predetermined distances along the Z axis. In one embodiment, a slab may have a width along the Z axis that is size constrained by the resolution of the imaging modality used to reconstruct the passageway models. For example, a slab width along the Z-axis may be approximately 0.5-0.675 mm and 0.5mm within a layer of the imaging modality (X-axis and Y-axis). In other embodiments, the width

of the slab along the Z-axis may be the entire model span. A slab may be defined to include multiple component slabs. For example, a selected 20mm slab may include four adjoining 5mm slabs. In another embodiment, the slabs may be a part of a hierarchical representation of the 3D space spanning the patient's anatomy (e.g., an octree). In yet another embodiment, the size of the slabs may be dynamic, being relatively large in areas of low interest to the anatomy (e.g., the trachea when the anatomy is the lungs), and progressively decreasing in size around regions of fine anatomical details (e.g., in the sub-segmental passages when the anatomy is lung).

In Fig. 4c and at step 306, a point  $P_L$ , which may generally correspond to the tip 126 or another known point or segment 137 of the instrument 120 begins a reference procedure with the sorted linked elements P1-P7. The point  $P_L$  is associated with reference information including position information and orientation information. The position information may include X, Y, Z coordinate information for the point  $P_L$ . The orientation information  $O_L$  may include orientation information related to pitch, yaw, and roll of the instrument 120 extending from point  $P_L$ . At step 308, the position information for point  $P_L$  is analyzed to determine a slab of points from among the points P1-P7 which have positions near the point  $P_L$ . For example, as shown in Fig. 4c, a slab 204, with a slab width  $W$  along the Z axis, includes the ordered points P7, P3, P1, and P5. A slab selected with a larger width may include more ordered points, and a slab selected with a smaller width may include fewer ordered points.

At step 310, within the selected slab 204 only, a pose match is conducted. A pose match includes a comparison of both the position information of point  $P_L$  and orientation information  $O_L$  to the pose information for each of the linked elements P7, P3, P1, and P5 and their connected linkages 202. A determination of a best match is based upon the distance of point  $P_L$  to linked elements P7, P3, P1, and P5 and the alignment of orientation vector  $O_L$  to the vectors  $V_{P1-P5}$ ,  $V_{P3-P1}$ , or  $V_{P7-P1}$ . The orientation comparison requires more time and computer processing resources than the position comparison alone. Thus, by limiting the detailed orientation comparison of  $P_L$  to only the points in the surrounding slab, time and processing resources may be conserved.

In Fig. 4d and at step 312,  $P_L$  is matched based on pose to P5. Thus, the portion of the instrument 120 associated with  $P_L$  is referenced to the point P5. A composite image can then be rendered depicting the point  $P_L$  of the instrument 120 at the location and orientation associated with the branch point P5 of the bronchial passageway. The point  $P_L$  can be snapped to the branch point P5 so that the composite image of the lung and the instrument

depicts the instrument within the bronchial passageway at the point P5.

Steps 306-312 can be repeated for additional points associated with one or more surgical instruments until an accurate rendering of surgical instruments registered with surgical images is complete.

5           Alternative systems and methods for registering an image of at least a portion of a flexible instrument to an image of an anatomical system are disclosed in U.S. Pat. App. No. (Ref. No. ISRG04300), disclosing “Systems and Methods for Deformation Compensation Using Shape Sensing” and in U.S. Pat. App. No. (Ref. No. ISRG04290), disclosing “Systems and Methods for Registration of a Medical Device Using a Reduced Search Space,” both of  
10           which are incorporated by reference herein in their entirety. Aspects of these incorporated by reference systems and methods may be used together with the above disclosed systems and methods to provide alternative methods of accurately registering an image of at least a portion of a flexible instrument to an image of an anatomical system.

          Although the registration systems and methods have been described herein with  
15           respect to teleoperated or hand operated surgical systems, these registration systems and methods will find application in a variety of medical and non-medical instruments in which accurate instrument image registration is otherwise too time consuming or computer processing intensive.

          Although the systems and methods of this disclosure have been illustrated for use in  
20           the connected bronchial passageways of the lung, they are also suited for navigation and treatment of other tissues, via natural or surgically created connected passageways, in any of a variety of anatomical systems including the colon, the intestines, the kidneys, the brain, the heart, the circulatory system, or the like. Treatments that may be performed with the systems and methods of this disclosure include exploration, biopsy, drug delivery, stenting  
25           procedures, aneurysm repair, and stimulation electrode placement. The methods and embodiments of this disclosure are also suitable for non-surgical applications.

          One or more elements in embodiments of the invention may be implemented in software to execute on a processor of a computer system such as control system 116. When  
30           implemented in software, the elements of the embodiments of the invention are essentially the code segments to perform the necessary tasks. The program or code segments can be stored in a processor readable storage medium or device that may have been downloaded by way of a computer data signal embodied in a carrier wave over a transmission medium or a communication link. The processor readable storage device may include any medium that



can store information including an optical medium, semiconductor medium, and magnetic medium. Processor readable storage device examples include an electronic circuit; a semiconductor device, a semiconductor memory device, a read only memory (ROM), a flash memory, an erasable programmable read only memory (EPROM); a floppy diskette, a CD-ROM, an optical disk, a hard disk, or other storage device, The code segments may be downloaded via computer networks such as the Internet, Intranet, etc.

Note that the processes and displays presented may not inherently be related to any particular computer or other apparatus. Various general-purpose systems may be used with programs in accordance with the teachings herein, or it may prove convenient to construct a more specialized apparatus to perform the operations described. The required structure for a variety of these systems will appear as elements in the claims. In addition, the embodiments of the invention are not described with reference to any particular programming language. It will be appreciated that a variety of programming languages may be used to implement the teachings of the invention as described herein.

While certain exemplary embodiments of the invention have been described and shown in the accompanying drawings, it is to be understood that such embodiments are merely illustrative of and not restrictive on the broad invention, and that the embodiments of the invention not be limited to the specific constructions and arrangements shown and described, since various other modifications may occur to those ordinarily skilled in the art.

20

## CLAIMS

What is claimed is:

1. A method comprising:
  - identifying linked anatomical structures in stored images of a patient anatomy;
  - 5 modeling a structure of linkage elements, wherein each linkage element corresponds to one of the linked anatomical structures;
  - modeling a portion of the patient anatomy as a plurality of search slabs;
  - assigning each of the linkage elements to one of the plurality of search slabs;
  - receiving tracking data corresponding to a sensed instrument portion, wherein the
  - 10 tracking data includes position information and orientation information for the sensed instrument portion;
  - identifying one of the plurality of search slabs which includes the position information for the sensed instrument portion; and
  - matching the sensed instrument portion to a matched linkage element from among the
  - 15 linkage elements assigned to the identified one of the plurality of search slabs.
2. The method of claim 1 further comprising:
  - receiving preoperative medical images into a computer memory device to create the
  - stored images of the patient anatomy.
  - 20
3. The method of claim 1 wherein the linked anatomical structures include airways of a lung.
4. The method of claim 1 wherein assigning each of the linkage elements to one of a
- 25 plurality of search slabs includes identifying a width dimension of each of the plurality of search slabs.
5. The method of claim 1 wherein matching the sensed instrument portion to the matched linkage element from among the linkage elements includes matching the orientation

information and the position information of the sensed instrument portion with orientation and position information for the matched linkage element.

6. The method of claim 1 further comprising:

5 generating corrected position information for the sensed instrument portion to match a location of the matched linkage element.

7. The method of claim 6 further comprising:

10 generating a composite image of the sensed instrument portion and the patient anatomy, including generating an image of the sensed instrument portion based upon the corrected position information.

8. The method of claim 1 further comprising generating a registry including the set of linkage elements sorted according to relative position along an axis.

15

9. The method of claim 8 wherein the axis is a generally caudal-cranio axis.

10. The method of claim 8 wherein the axis is along a planned access path through the patient anatomy.

20

11. A medical system comprising:

a memory storing images of a patient anatomy; and

a processor configured for

identifying linked anatomical structures in the stored images of a patient

25

anatomy;

receiving the tracking data, wherein the tracking data includes position information and orientation information for a sensed instrument portion;

modifying the tracking data to generate snapped position and snapped orientation information for the sensed instrument portion;

rendering a composite medical image, wherein the composite medical image includes an image of at least a portion of the linked anatomical structures and an image of the sensed instrument portion in the snapped position and snapped orientation.

5

12. The medical system of claim 11 wherein the processor is further configured for:
- modeling a structure of linkage elements, wherein each linkage element corresponds to one of the linked anatomical structures;
  - assigning each of the linkage elements to one of a plurality of search slabs;
  - 10 identifying one of the plurality of search slabs which includes the position information; and
  - matching the sensed instrument portion to a matched linkage element from among the linkage elements assigned to the identified one of the plurality of search slabs.

15

13. The medical system of claim 11 wherein the stored images of the patient anatomy include
- preoperatively recorded medical images.

20

14. The medical system of claim 11 wherein the linked anatomical structures include airways of a lung.

15. The medical system of claim 11 wherein the linked anatomical structures include a cardiovascular system.

25

16. The medical system of claim 11 wherein the linked anatomical structures include a brain circulatory system.

17. The medical system of claim 11 further comprising an instrument including the sensed instrument portion and a sensor adapted to provide tracking data for the sensed instrument portion.

5 18. The medical system of claim 17 wherein the instrument includes an elongated, flexible body.

19. The medical system claim 12 wherein assigning each of the linkage elements to one of a plurality of search slabs includes identifying a width dimension of each of the plurality of  
10 search slabs.

20. The medical system of claim 12 wherein matching the sensed instrument portion to the matched linkage element from among the linkage elements includes matching the orientation information and the position information of the sensed instrument portion with  
15 orientation and position information for the matched linkage element.

21. The medical system of claim 12 wherein modifying the tracking data to generate snapped position and snapped orientation information for the sensed instrument portion includes generating the snapped position information to match a location of the matched  
20 linkage element.

22. The medical system of claim 11 wherein the memory further comprises a registry including each linkage element sorted according to relative position along an axis.

25 23. The medical system of claim 22 wherein the axis is a generally caudal-cranio axis.

24. A method comprising:

rendering a composite medical image, wherein the composite medical image includes an image of a plurality of passageways in a patient anatomy and an image of a medical instrument; and

5           correcting the image of the medical instrument to position a point on the medical instrument within one of the plurality of passageways in the composite medical image, wherein correcting the image includes generating a model of the plurality of passageways, identifying one of a plurality of slabs of the model that includes a position of the medical instrument, and matching a pose of a point in one of the plurality of passageways in the slab  
10 to a pose of a point on the medical instrument.

25. The method of claim 24 further comprising displaying the corrected image with the point on the medical instrument snapped to the matched one of the plurality of passageways.

15 26. The method of claim 24 wherein the step of correcting the image further includes assigning each of the plurality of passageways to one of a plurality of slabs of the model.

27. The method of claim 24 wherein the step of matching a point on one of the plurality of passageways in the slab to the point on the medical instrument includes matching position  
20 and orientation information for the point on the medical instrument to one of the plurality of passageways in the slab.

25

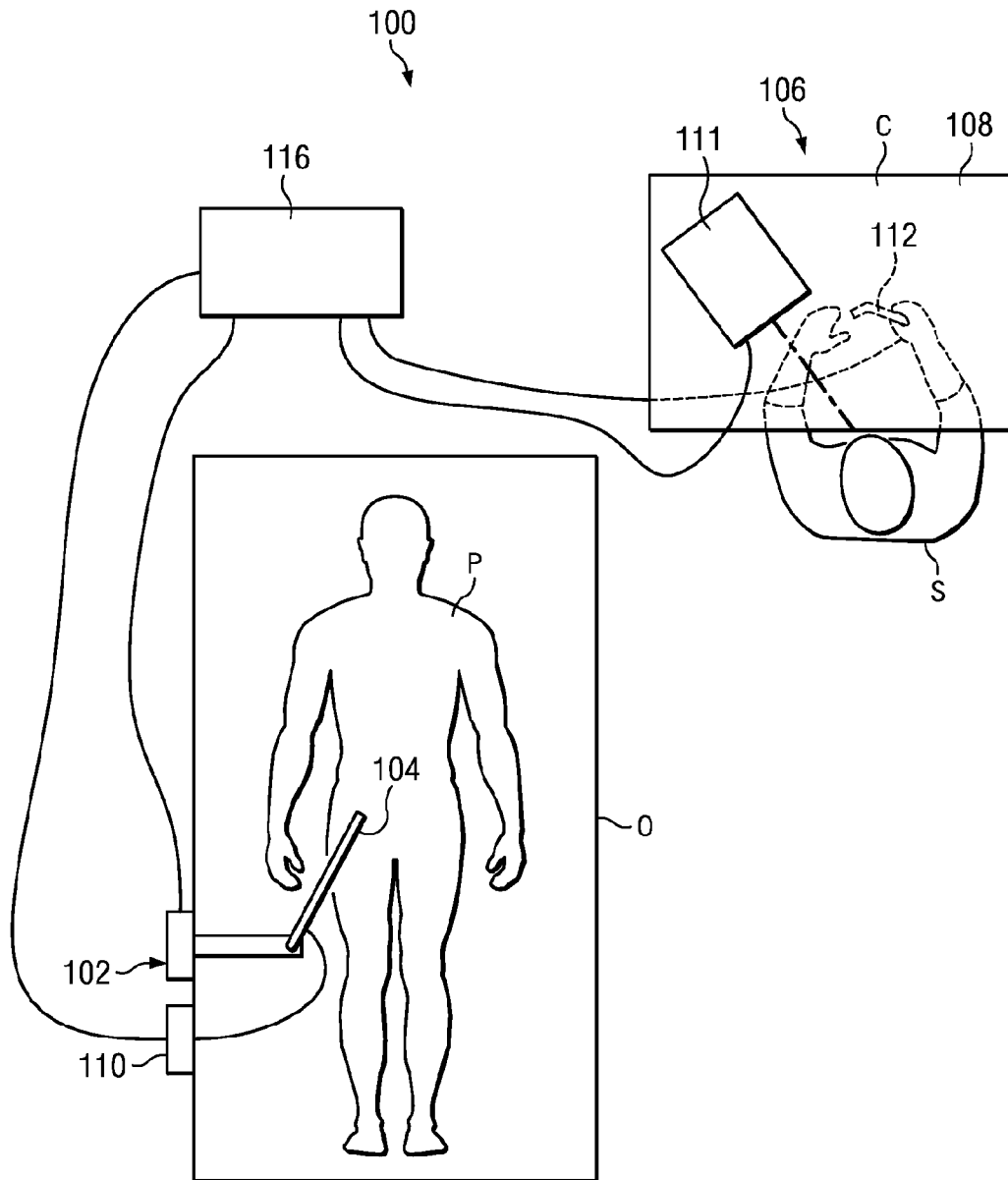

Fig. 1





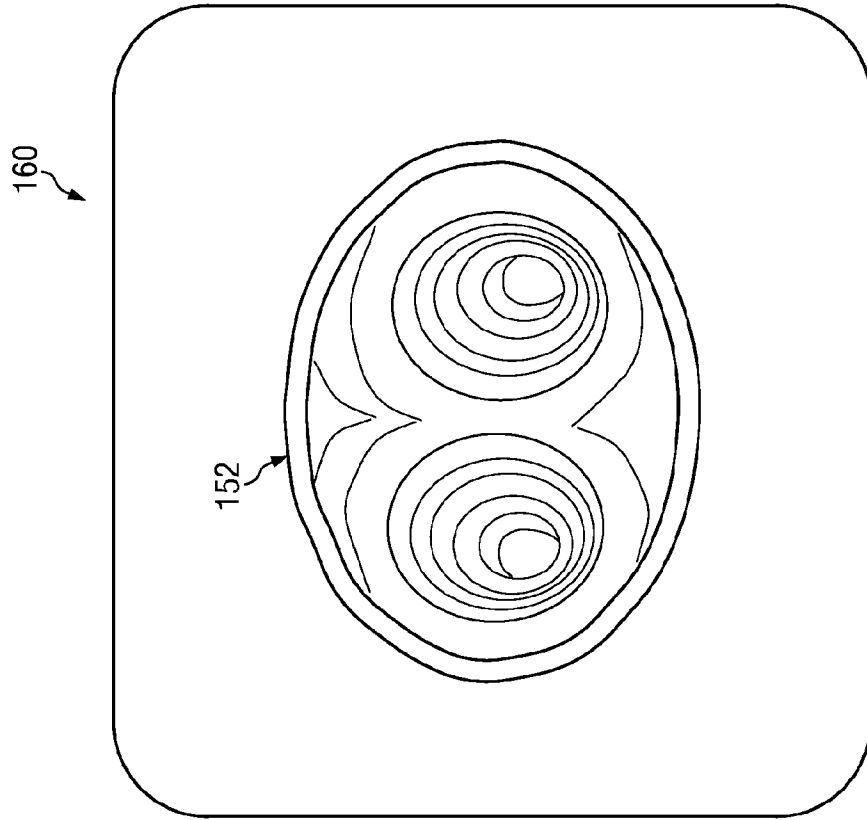

Fig. 3a

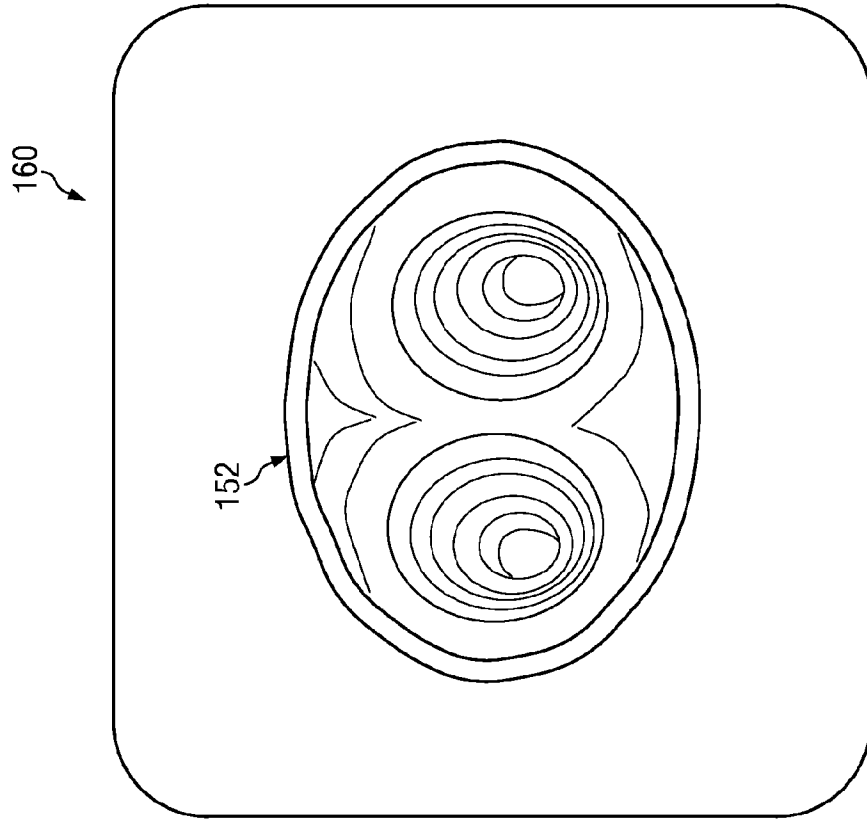
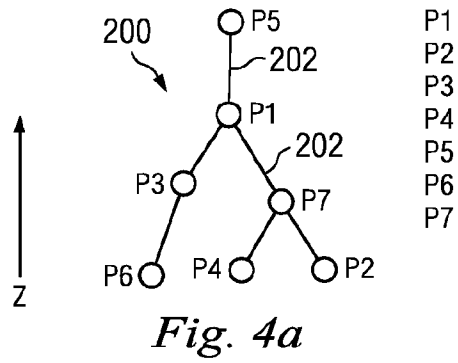
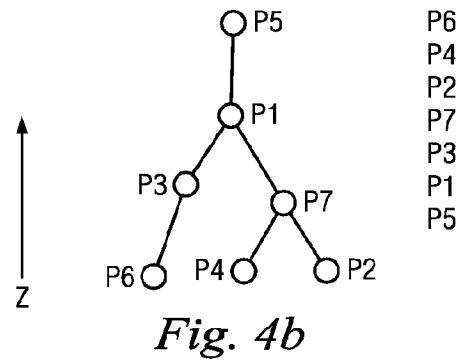

Fig. 3b



- P1
- P2
- P3
- P4
- P5
- P6
- P7



- P6
- P4
- P2
- P7
- P3
- P1
- P5

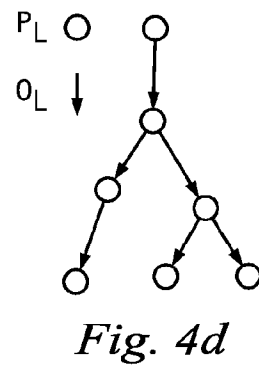
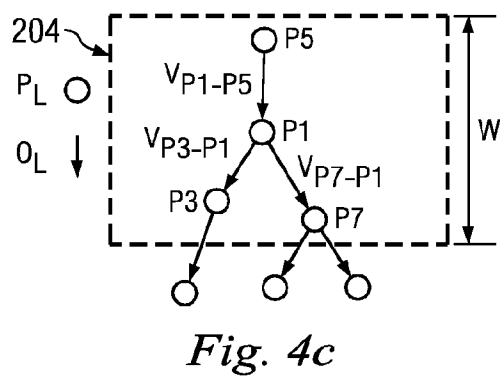

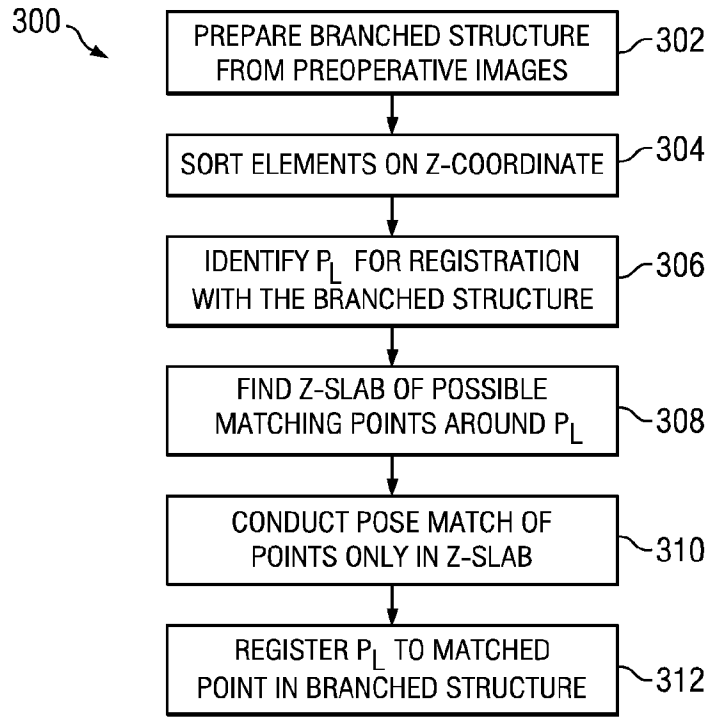

Fig. 5

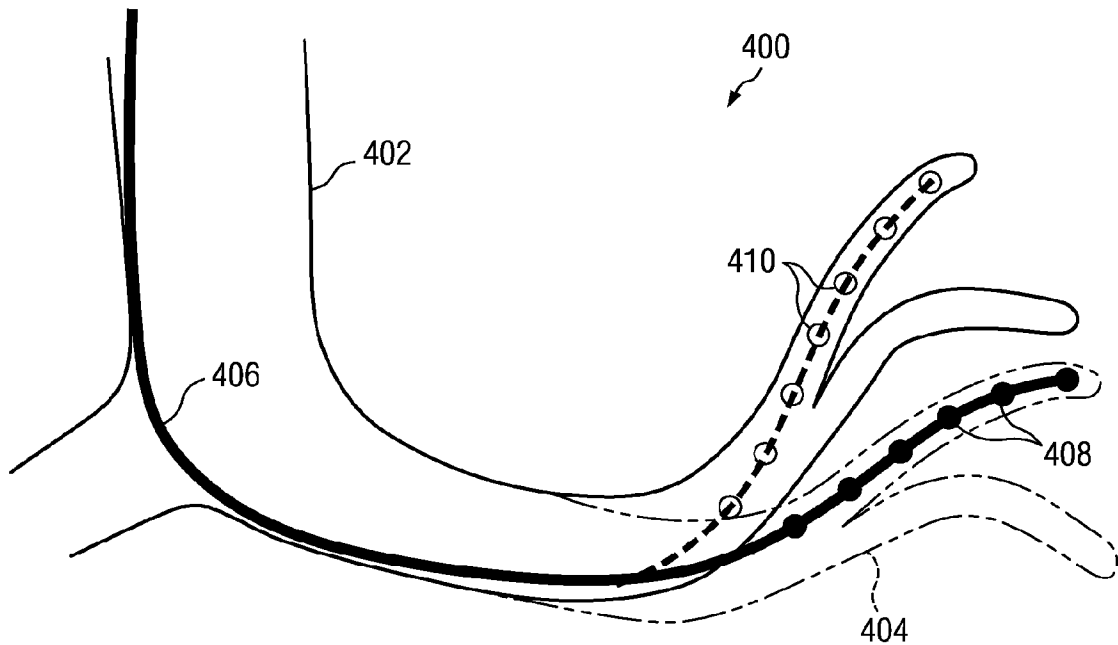

Fig. 6

## INTERNATIONAL SEARCH REPORT

International application No.  
**PCT/US2013/040786****A. CLASSIFICATION OF SUBJECT MATTER****A61B 19/00(2006.01)i, A61B 18/00(2006.01)i**

According to International Patent Classification (IPC) or to both national classification and IPC

**B. FIELDS SEARCHED**Minimum documentation searched (classification system followed by classification symbols)  
A61B 19/00; A61B 1/00; G06N 5/04; G06T 15/00; G06K 9/00; A61B 1/04; A61B 18/00Documentation searched other than minimum documentation to the extent that such documents are included in the fields searched  
Korean utility models and applications for utility models  
Japanese utility models and applications for utility modelsElectronic data base consulted during the international search (name of data base and, where practicable, search terms used)  
eKOMPASS(KIPO internal) & Keywords: position sensor, image, tracking data, processor, image rendering**C. DOCUMENTS CONSIDERED TO BE RELEVANT**

Category*	Citation of document, with indication, where appropriate, of the relevant passages	Relevant to claim No.
X	US 7901348 B2 (SOPER, T. D. et al.) 8 March 2011 See abstract; figs. 2A, 2B, and 4A; column 5, lines 33-36; column 12, lines 34-67; claims 1, 2, and 8.	11, 13-18, 22, 23
A		12, 19-21
A	US 2009-0268955 A1 (KOOLWAL, A. et al.) 29 October 2009 See abstract; claims 1 and 6.	11-23
A	US 2009-0209817 A1 (AVERBUCH, D.) 20 August 2009 See abstract; claims 1 and 15.	11-23
A	US 2012-0069167 A1 (LIU, X. et al.) 22 March 2012 See abstract; claims 1 and 19.	11-23
A	US 2011-0282151 A1 (TROVATO, K. I. et al.) 17 November 2011 See abstract; claims 1 and 11-15.	11-23

 Further documents are listed in the continuation of Box C. See patent family annex.

\* Special categories of cited documents:

"A" document defining the general state of the art which is not considered to be of particular relevance

"E" earlier application or patent but published on or after the international filing date

"L" document which may throw doubts on priority claim(s) or which is cited to establish the publication date of citation or other special reason (as specified)

"O" document referring to an oral disclosure, use, exhibition or other means

"P" document published prior to the international filing date but later than the priority date claimed

"T" later document published after the international filing date or priority date and not in conflict with the application but cited to understand the principle or theory underlying the invention

"X" document of particular relevance; the claimed invention cannot be considered novel or cannot be considered to involve an inventive step when the document is taken alone

"Y" document of particular relevance; the claimed invention cannot be considered to involve an inventive step when the document is combined with one or more other such documents, such combination being obvious to a person skilled in the art

"&amp;" document member of the same patent family

Date of the actual completion of the international search

09 August 2013 (09.08.2013)

Date of mailing of the international search report

**12 August 2013 (12.08.2013)**

Name and mailing address of the ISA/KR

 Korean Intellectual Property Office  
 189 Cheongsu-ro, Seo-gu, Daejeon Metropolitan City,  
 302-701, Republic of Korea

Facsimile No. +82-42-472-7140

Authorized officer

HAN In Ho

Telephone No. +82-42-481-3362



**Box No. II Observations where certain claims were found unsearchable (Continuation of item 2 of first sheet)**

This international search report has not been established in respect of certain claims under Article 17(2)(a) for the following reasons:

1.  Claims Nos.: 1-10,24-27  
because they relate to subject matter not required to be searched by this Authority, namely:  
Claims 1-10 and 24-27 pertain to diagnostic methods of the human and thus relate to a subject-matter which this International Searching Authority is not required, under Article 17(2)(a)(i) of the PCT and Rule 39.1(iv) of the Regulations under the PCT, to search.
2.  Claims Nos.:  
because they relate to parts of the international application that do not comply with the prescribed requirements to such an extent that no meaningful international search can be carried out, specifically:
3.  Claims Nos.:  
because they are dependent claims and are not drafted in accordance with the second and third sentences of Rule 6.4(a).

**Box No. III Observations where unity of invention is lacking (Continuation of item 3 of first sheet)**

This International Searching Authority found multiple inventions in this international application, as follows:

1.  As all required additional search fees were timely paid by the applicant, this international search report covers all searchable claims.
2.  As all searchable claims could be searched without effort justifying an additional fee, this Authority did not invite payment of any additional fee.
3.  As only some of the required additional search fees were timely paid by the applicant, this international search report covers only those claims for which fees were paid, specifically claims Nos.:
4.  No required additional search fees were timely paid by the applicant. Consequently, this international search report is restricted to the invention first mentioned in the claims; it is covered by claims Nos.:

**Remark on Protest**

- The additional search fees were accompanied by the applicant's protest and, where applicable, the payment of a protest fee.
- The additional search fees were accompanied by the applicant's protest but the applicable protest fee was not paid within the time limit specified in the invitation.
- No protest accompanied the payment of additional search fees.

**INTERNATIONAL SEARCH REPORT**

Information on patent family members

International application No.

**PCT/US2013/040786**

Patent document cited in search report	Publication date	Patent family member(s)	Publication date
US 7901348 B2	08/03/2011	EP 1691666 A2	23/08/2006
		EP 1691666 A4	02/04/2008
		EP 1691666 B1	30/05/2012
		US 2005-0182295 A1	18/08/2005
		US 2006-0149134 A1	06/07/2006
		US 8382662 B2	26/02/2013
		WO 2005-058137 A2	30/06/2005
		WO 2005-058137 A3	11/05/2006
US 2009-0268955 A1	29/10/2009	US 8270694 B2	18/09/2012
US 2009-0209817 A1	20/08/2009	EP 2247236 A2	10/11/2010
		EP 2247236 A4	08/08/2012
		WO 2009-101504 A2	20/08/2009
		WO 2009-101504 A3	23/12/2009
US 2012-0069167 A1	22/03/2012	CN 102428496 A	25/04/2012
		EP 2433262 A2	28/03/2012
		TW 201108158 A	01/03/2011
		WO 2010-133982 A2	25/11/2010
		WO 2010-133982 A3	13/01/2011
US 2011-0282151 A1	17/11/2011	CN 102186404 A	14/09/2011
		EP 2348954 A1	03/08/2011
		JP 2012-505695 A	08/03/2012
		WO 2010-046802 A1	29/04/2010