



US0D1045798S

(12) **United States Design Patent**  
**Stockman**

(10) **Patent No.:** **US D1,045,798 S**

(45) **Date of Patent:** **\*\* Oct. 8, 2024**

(54) **CAPACITOR**

(56)

**References Cited**

- (71) Applicant: **AmRad Manufacturing, LLC**,  
Universal City, TX (US)
- (72) Inventor: **Robert M. Stockman**, Palm Coast, FL  
(US)
- (73) Assignee: **AmRad Manufacturing, LLC**,  
Universal City, TX (US)
- (\*\*) Term: **15 Years**
- (21) Appl. No.: **29/814,809**
- (22) Filed: **Nov. 9, 2021**

U.S. PATENT DOCUMENTS

1,665,499	A	4/1928	Hoch
1,707,959	A	4/1929	Fried
1,789,949	A	1/1931	Georgiev
1,943,714	A	1/1934	Bailey
2,050,062	A	8/1936	Mershon
2,202,166	A	5/1940	Peck
D122,825	S	10/1940	Peck
D124,726	S	1/1941	Shimer
D130,952	S	12/1941	Miller
2,296,123	A	9/1942	Stimson
2,569,925	A	10/1951	Deeley
2,607,833	A	8/1952	Schomaker
2,779,813	A	1/1957	Collins
2,896,008	A	7/1959	Putz
2,968,752	A	1/1961	Rubinstein
2,974,234	A	3/1961	Rowe
3,010,056	A	11/1961	Kurland
3,015,687	A	1/1962	Ruscito
3,041,477	A	6/1962	Lucien et al.
3,210,457	A	10/1965	Hancock
3,246,205	A	4/1966	Miller
3,302,081	A	1/1967	Grahame
3,304,473	A	2/1967	Netherwood et al.
D209,054	S	10/1967	Braiman et al.
D210,210	S	2/1968	Braiman et al.
3,377,510	A	4/1968	Rayno
3,454,858	A	7/1969	Robinson
3,473,088	A	10/1969	Ernst
3,524,614	A	8/1970	Sorth
3,553,542	A	1/1971	Stonemetz
3,555,370	A	1/1971	Bowling
3,593,066	A	7/1971	Norman
3,771,321	A	11/1973	Maksy
3,803,457	A	4/1974	Yamamoto
3,921,041	A	11/1975	Stockman
3,955,170	A	5/1976	Geishecker
3,988,650	A	10/1976	Fritze
4,009,425	A	2/1977	Muranaka
4,028,595	A	6/1977	Stockman
4,095,902	A	6/1978	Florer et al.
4,106,068	A	8/1978	Flanagan
4,107,758	A	8/1978	Shirn et al.
4,112,424	A	9/1978	Lapeyre
4,112,474	A	9/1978	Wilson et al.
D253,887	S	1/1980	Truner et al.
4,190,702	A	2/1980	Pun et al.
4,209,815	A	6/1980	Rollins et al.
4,240,126	A	12/1980	Sanvito
4,263,638	A	4/1981	Stockman et al.

**Related U.S. Application Data**

- (63) Continuation of application No. 29/667,335, filed on Oct. 19, 2018, now Pat. No. Des. 938,912, which is a continuation of application No. 15/585,782, filed on May 3, 2017, now Pat. No. 10,134,528, which is a continuation of application No. 15/097,383, filed on Apr. 13, 2016, now Pat. No. 10,249,439, which is a continuation of application No. 13/601,205, filed on Aug. 31, 2012, now Pat. No. 9,343,238, which is a continuation of application No. 12/945,979, filed on Nov. 15, 2010, now Pat. No. 8,270,143, which is a continuation of application No. 12/246,676, filed on Oct. 7, 2008, now Pat. No. 7,835,133, which is a continuation of application No. 11/733,624, filed on Apr. 10, 2007, now Pat. No. 7,474,519, which is a continuation of application No. 11/317,700, filed on Dec. 23, 2005, now Pat. No. 7,203,053.
- (51) **LOC (14) Cl.** ..... **13-03**
- (52) **U.S. Cl.**  
USPC ..... **D13/124**
- (58) **Field of Classification Search**  
USPC ..... D13/123-132, 154, 199, 184  
CPC ..... H01G 4/224; H01G 4/28; H01G 4/385;  
H01G 4/40; H01G 4/232  
See application file for complete search history.

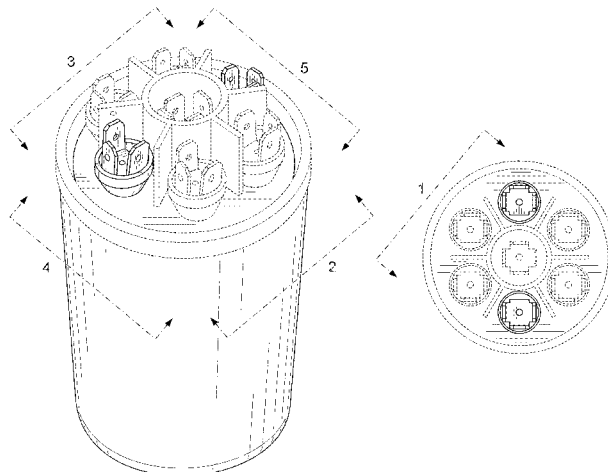

# US D1,045,798 S

Page 2

4,312,027 A	1/1982	Stockman	6,466,429 B1	10/2002	Volkovich et al.
4,326,237 A	4/1982	Markarian et al.	6,490,158 B1	12/2002	Ellyson et al.
4,352,145 A	9/1982	Stockman	6,538,544 B1	3/2003	Hardy
4,360,848 A	11/1982	Noutko et al.	6,552,893 B2	4/2003	Tanaka
4,363,078 A	12/1982	Dwyer	6,697,249 B2	2/2004	Maletin et al.
4,388,669 A	6/1983	Cichanowski	6,706,079 B1	3/2004	Shmatko et al.
4,398,782 A	8/1983	Markarian	6,720,689 B2	4/2004	Agnes et al.
4,408,818 A	10/1983	Markarian	6,798,677 B2	9/2004	Jakob et al.
4,420,791 A	12/1983	Shedigian	6,807,048 B1	10/2004	Nielsen
4,447,854 A	5/1984	Markarian	6,816,541 B1	11/2004	Hong
4,459,637 A	7/1984	Shedigian	6,819,545 B1	11/2004	Lobo et al.
4,486,809 A	12/1984	Deak et al.	6,842,328 B2	1/2005	Schott
4,546,300 A	10/1985	Shaikh	6,847,517 B2	1/2005	Iwaida et al.
4,558,394 A	12/1985	Stockman	D505,211 S	5/2005	Stanchfield
4,586,107 A	4/1986	Price	6,888,266 B2	5/2005	Burke et al.
4,609,967 A	9/1986	Shedigian	6,922,330 B2	7/2005	Nielson et al.
4,621,301 A	11/1986	Shedigian	6,930,874 B2	8/2005	Lobo et al.
4,631,631 A	12/1986	Hodges et al.	6,982,539 B1	1/2006	Ward
4,633,365 A	12/1986	Stockman	6,995,971 B2	2/2006	Norton
4,633,367 A	12/1986	Strange et al.	7,031,139 B1	4/2006	Fayram
4,633,369 A	12/1986	Lapp et al.	7,046,498 B1	5/2006	Huang
4,639,828 A	1/1987	Strange et al.	D522,456 S	6/2006	Matsumoto
4,642,731 A	2/1987	Shedigian	D524,758 S	7/2006	Sweeney
4,698,725 A	10/1987	MacDougall et al.	D525,209 S	7/2006	Sweeney
4,737,785 A	4/1988	Zottnik	D529,202 S	9/2006	Nagai et al.
4,754,361 A	6/1988	Venturini	7,110,240 B2	9/2006	Breyen
4,757,414 A	7/1988	Barker et al.	7,184,256 B1	2/2007	Sato
4,768,129 A	8/1988	Sasaki	D541,218 S	4/2007	Colopy
4,811,161 A	3/1989	Sasaki	7,203,053 B2	4/2007	Stockman
4,812,941 A	3/1989	Rice et al.	7,206,186 B1	4/2007	Knight
4,813,116 A	3/1989	Thiel et al.	D541,746 S	5/2007	Colopy
4,897,760 A	1/1990	Bourbeau	7,251,123 B2	7/2007	O'Phelan
D307,000 S	4/1990	Sasaki	D551,943 S	10/2007	Hodjat
4,992,910 A	2/1991	Evans	D562,237 S	2/2008	Tu
5,006,726 A	4/1991	Okumura	7,337,945 B1	3/2008	Riggs et al.
5,019,934 A	5/1991	Bentley et al.	7,365,959 B1	4/2008	Ward
5,032,948 A	7/1991	Sakai	D573,008 S	7/2008	Sipe
5,138,519 A	8/1992	Stockman	7,423,861 B2	9/2008	Stockman
5,148,347 A	9/1992	Cox et al.	7,474,519 B2	1/2009	Stockman
5,162,718 A	11/1992	Schroeder	7,474,520 B2	1/2009	Kashihara
5,196,818 A	3/1993	Anderson	7,492,574 B2	2/2009	Fresard et al.
5,247,236 A	9/1993	Schroeder	7,511,941 B1	3/2009	Gallay
5,280,219 A	1/1994	Ghanbari	7,547,233 B2	6/2009	Inoue et al.
5,313,360 A	5/1994	Stockman	7,619,420 B2	11/2009	Stockman
5,381,301 A	1/1995	Hudis	7,667,954 B2	2/2010	Lessner
5,412,532 A	5/1995	Nishimori	7,710,713 B2	5/2010	Restorff
5,528,120 A	6/1996	Brodetsky	D621,789 S	8/2010	Wang et al.
5,561,357 A	10/1996	Schroeder	D623,500 S	9/2010	Langner
5,673,168 A	9/1997	Efford et al.	7,835,133 B2	11/2010	Stockman
5,691,845 A	11/1997	Iwatsuka et al.	7,848,079 B1	12/2010	Gordin et al.
5,817,975 A	10/1998	Heilmann et al.	7,867,290 B2	1/2011	Nielsen
5,847,919 A	12/1998	Shimizu et al.	7,881,043 B2	2/2011	Hirose et al.
5,866,276 A	2/1999	Ogami et al.	7,911,762 B2	3/2011	Stockman
D408,266 S	4/1999	Santiago	7,911,766 B2	3/2011	Caumont et al.
5,921,820 A	7/1999	Dijkstra	7,952,854 B2	5/2011	Stockman
5,940,263 A	8/1999	Jakubovitch	7,987,593 B1	8/2011	Gorst
6,009,348 A	12/1999	Rorvick et al.	8,029,290 B2	10/2011	Johnson
6,014,308 A	1/2000	Stockman	8,159,810 B1	4/2012	Gorst et al.
6,031,713 A	2/2000	Takeisha et al.	8,170,662 B2	5/2012	Bocek
6,064,563 A	5/2000	Yamada et al.	8,174,817 B2	5/2012	Georgopoulos et al.
6,084,764 A	7/2000	Anderson	8,270,143 B2	9/2012	Stockman
6,141,205 A	10/2000	Nutzman	8,274,778 B2	9/2012	Yoshinaga et al.
6,147,856 A	11/2000	Karidis	8,310,802 B2	11/2012	Fujii et al.
6,157,531 A	12/2000	Breyen et al.	8,331,076 B2	12/2012	Tuncer
6,160,465 A	12/2000	Yamaguchi et al.	D681,438 S	5/2013	Chen
6,212,058 B1	4/2001	Huber	8,456,795 B2	6/2013	Stockman
6,222,270 B1	4/2001	Lee	8,465,555 B2	6/2013	Sherwood
6,229,236 B1	5/2001	Fisher	8,472,164 B2	6/2013	Kim
6,233,133 B1	5/2001	Weng	8,514,547 B2	8/2013	Galvagni
6,282,078 B1	8/2001	Tsai	8,514,548 B2	8/2013	Miller et al.
6,282,081 B1	8/2001	Takabayashi et al.	8,531,815 B2	9/2013	Stockman
6,310,756 B1	10/2001	Miura et al.	8,537,522 B2	9/2013	Stockman
6,313,978 B1	11/2001	Stockman et al.	8,559,161 B2	10/2013	Takeoka et al.
6,320,348 B1	11/2001	Kadah	8,619,409 B2	12/2013	Yawata et al.
6,373,720 B1	4/2002	Fechtig et al.	D707,639 S	6/2014	Rego
6,385,490 B1	5/2002	O'Phelan	8,761,875 B2	6/2014	Sherwood
6,404,618 B1	6/2002	Beard et al.	8,842,411 B2	9/2014	Zhang
6,410,184 B1	6/2002	Horiuchi	8,853,318 B2	10/2014	Tielemans
D464,028 S	10/2002	Clark	8,861,178 B2	10/2014	Terashima et al.

8,861,184	B2	10/2014	Schmidt	2009/0059463	A1	3/2009	Ward
8,871,850	B2	10/2014	Koh et al.	2009/0115557	A1	5/2009	Minowa
8,885,318	B2	11/2014	Stockman	2009/0219665	A1	9/2009	Stockman
8,891,224	B2	11/2014	Stockman	2009/0261762	A1	10/2009	Tsuchiya
D728,480	S	5/2015	Chang	2011/0063775	A1	3/2011	Stockman
D729,164	S	5/2015	Chen	2011/0075342	A1	3/2011	Gotham et al.
9,105,401	B2	8/2015	Dreissig	2011/0134584	A1	6/2011	Stockman
D747,225	S	1/2016	Decook	2011/0157764	A1	6/2011	Stockman
9,318,261	B2	4/2016	Stockman	2011/0228444	A1	9/2011	Lai et al.
9,324,501	B2	4/2016	Stockman	2011/0228446	A1	9/2011	Stockman
9,343,238	B2	5/2016	Stockman	2011/0317333	A1	12/2011	Chun
9,378,893	B2	6/2016	Stockman	2012/0026046	A1	2/2012	Bit-Babik
9,412,521	B2	8/2016	Stockman	2013/0003252	A1	1/2013	Stockman
9,424,995	B2	8/2016	Stockman	2013/0214720	A1	8/2013	Stockman
9,466,429	B1	10/2016	Casanova	2013/0329342	A1	12/2013	Stockman
D771,567	S	11/2016	Flohe et al.	2013/0343029	A1	12/2013	Stockman
9,496,086	B2	11/2016	Stockman	2014/0049205	A1	2/2014	Curiel
9,536,670	B2	1/2017	Stockman	2014/0126107	A1	5/2014	Yoda et al.
D795,819	S	8/2017	Okamoto et al.	2014/0138009	A1	5/2014	Lim
9,859,060	B1	1/2018	Stockman et al.	2014/0201018	A1	7/2014	Chassin
9,916,934	B1	3/2018	Casanova et al.	2014/0232485	A1	8/2014	Bultitude
9,947,467	B2	4/2018	Goodson et al.	2014/0285949	A1	9/2014	Stockman
D816,470	S	5/2018	Green	2014/0347784	A1	11/2014	Stockman et al.
D818,437	S	5/2018	Stockman	2015/0016012	A1	1/2015	Stockman
D818,959	S	5/2018	Stockman	2015/0022991	A1	1/2015	Stockman et al.
10,056,194	B2	8/2018	Stockman	2015/0138690	A1	5/2015	Stockman
10,056,195	B2	8/2018	Stockman	2015/0255218	A1	9/2015	Stockman et al.
D829,173	S	9/2018	Stockman	2015/0287308	A1	10/2015	Shuttleworth
10,134,528	B2	11/2018	Stockman	2016/0028230	A1	1/2016	Elfman
10,147,549	B2	12/2018	Stockman	2016/0203916	A1	7/2016	Stockman
10,147,550	B1	12/2018	Stockman	2016/0233030	A1	8/2016	Stockman
10,163,571	B2	12/2018	Stockman	2017/0011855	A1	1/2017	Stockman et al.
10,209,751	B2	2/2019	Zikes	2017/0032898	A1	2/2017	Stockman
10,249,439	B2	4/2019	Stockman	2017/0110252	A1	4/2017	Stockman
10,256,195	B2	4/2019	Yamamoto	2017/0186554	A1	6/2017	Stockman
10,366,840	B1	7/2019	Stockman	2017/0229242	A1	8/2017	Goodson et al.
10,475,588	B2	11/2019	Stockman	2017/0236646	A1	8/2017	Stockman
10,497,518	B1	12/2019	Stockman	2017/0372838	A1	12/2017	Casanova et al.
10,497,520	B1	12/2019	Stockman	2018/0061600	A1	3/2018	Ito
10,586,655	B1	3/2020	Stockman	2018/0090278	A1	3/2018	Stockman et al.
D886,741	S	6/2020	Okajima et al.	2018/0254150	A1	9/2018	Stockman et al.
D892,741	S	8/2020	Biere	2018/0261391	A1	9/2018	Stockman
D893,441	S	8/2020	Rao	2019/0057815	A1	2/2019	Stockman
D906,247	S	12/2020	Stockman	2019/0057817	A1	2/2019	Stockman
D906,969	S	1/2021	Stockman	2020/0066470	A1	2/2020	Mitchell
D914,605	S	3/2021	Xin	2020/0143994	A1	5/2020	Stockman
11,177,074	B1	11/2021	Stockman	2020/0155983	A1	5/2020	Maeda
11,183,330	B2	11/2021	Stockman	2020/0161057	A1	5/2020	Stockman et al.
11,183,335	B2	11/2021	Stockman	2020/0211780	A1	7/2020	Stockman
11,183,336	B2	11/2021	Stockman	2020/0251285	A1	8/2020	Stockman
11,183,337	B1	11/2021	Stockman	2022/0328247	A1	10/2022	Stockman
11,183,338	B2	11/2021	Stockman	2022/0328254	A1	10/2022	Stockman
11,183,341	B1	11/2021	Stockman	2022/0336156	A1	10/2022	Stockman
11,189,425	B1	11/2021	Stockman et al.	2022/0336157	A1	10/2022	Stockman
11,189,426	B1	11/2021	Stockman	2022/0336161	A1	10/2022	Stockman
D937,785	S	12/2021	Hess	2022/0344101	A1	10/2022	Stockman
D938,912	S	12/2021	Stockman	2022/0352789	A1	11/2022	Waldrop et al.
11,195,663	B2	12/2021	Stockman	2022/0392710	A1	12/2022	Stockman
11,424,077	B1	8/2022	Stockman et al.	2023/0261549	A1	8/2023	Waldrop et al.
11,575,298	B2	2/2023	Waldrop et al.	2023/0307188	A9	9/2023	Stockman
2001/0025618	A1	10/2001	Kelling	2023/0307189	A1	9/2023	Stockman
2002/0030548	A1	3/2002	Dejima	2023/0411082	A1	12/2023	Stockman
2005/0272012	A1	12/2005	Logan et al.	2024/0006126	A1	1/2024	Stockman
2006/0007387	A1	1/2006	Xiao	2024/0029961	A1	1/2024	Stockman
2006/0050468	A1	3/2006	Inoue et al.	2024/0087811	A1	3/2024	Stockman
2006/0067031	A1	3/2006	Crane				
2006/0201971	A1	9/2006	Wegman				
2006/0227495	A1	10/2006	Stockman				
2007/0025051	A1	2/2007	Stockman				
2007/0221278	A1	9/2007	Sartorius	CA	2285721	4/2000	
2007/0236860	A1	10/2007	Stockman	CA	188725	12/2021	
2007/0279015	A1	12/2007	Livingston et al.	CA	204951	12/2021	
2007/0283707	A1	12/2007	Hatano	CA	204952	* 1/2022	
2007/0295877	A1	12/2007	Gaydos	CN	2033169	2/1989	
2008/0025549	A1	1/2008	Avera	CN	3607691	* 2/2007	
2008/0158780	A1	7/2008	Stockman	CN	101991323	3/2011	
2008/0217053	A1	9/2008	Vojtila et al.	CN	301914077	* 2/2012	
2009/0001921	A1	1/2009	Mills	CN	104201077	12/2014	
2009/0052109	A1	2/2009	Stockman et al.	CN	204351550	5/2015	
				CN	204539389	8/2015	

## FOREIGN PATENT DOCUMENTS

CN	304472828	*	1/2018
CN	304806073		9/2018
CN	305610350		2/2020
CN	305625370		2/2020
CN	305780976		5/2020
CN	308082810		6/2023
EP	129714		1/1985
EP	1115128		7/2001
EP	2587503		3/2014
FR	2343221		9/1977
FR	2802708		6/2001
GB	517718		2/1940
GB	2169747		7/1986
GB	2070861		12/1997
JP	S498747	A	1/1974
JP	S498748		2/1974
JP	H04139807		5/1992
JP	07211596	A	8/1995
JP	D1273871		6/2006
JP	D1288240		12/2006
JP	2007059477	A	3/2007
JP	D1456333		11/2012
JP	2015130259		7/2015
KR	20160061825		6/2016
MX	62279		8/2021
MX	65643		12/2022
WO	WO 2010031594		3/2010
WO	WO 2010037186		4/2010
WO	WO 2014190072		11/2014
WO	WO 2020123834		6/2020

## OTHER PUBLICATIONS

US 10,504,654 B2, 12/2019, Stockman (withdrawn)

Amazon. Link: <https://www.amazon.com/dp/B094C8P8NT/>. May 7, 2021. BlueStars 35+3 MFD uf 370 or 440 Volt Dual Run Round Capacitor CBB65 Replacement Part (Year: 2021).\*

Ktool. Link: [https://www.ktool.net/mars-12200-turbo-200-2-5-5-5-10-20-25-mfd-universal-round-run-capacitor/?gclid=EAlalQobChMI87646ZyggAMVvX9MChOcFgwbEAQYBCABFgIXV\\_D\\_BwE](https://www.ktool.net/mars-12200-turbo-200-2-5-5-5-10-20-25-mfd-universal-round-run-capacitor/?gclid=EAlalQobChMI87646ZyggAMVvX9MChOcFgwbEAQYBCABFgIXV_D_BwE). Visited Jul. 21, 2023. Mars 12200 Turbo 200 2.5/5/5/10/20/25 MFD Universal Round Run Capacitor (Year: 2023).\*

Supplyhouse. Link: <https://www.supplyhouse.com/MARS-12200-2-5-67-5-MFD-AmRad-Turbo-200-Universal-Capacitor-370-440V>. Visited Jul. 21, 2023. 2.5-67.5 MFD, AmRad Turbo 200 Universal Capacitor (370/440V) (Year: 2023).\*

Ebay, "25+3 uF MFD x 370 / 440 VAC Motor Run Capacitor AmRad USA2224BA—Made in USA," ebay.com, 2020 retrieved from URL: <https://www.ebay.com/itm/25-3-uF-MFD-x-370-440-VAC-Motor-Run-Capacitor-AmRad-USA2224BA-Made-in-USA-/164162793031>; retrieved on Oct. 28, 2020, 15 pages.

NMR.mgh.harvard.edu [online], "Strategies to Repair or Replace Old Electrolytic Capacitors," available on or before Nov. 30, 2001, via Internet Archive: Wayback Machine URL: <https://web.archive.org/web/20011130084328/https://www.nmr.mgh.harvard.edu/~reese/electrolytics/> retrieved on Apr. 22, 2021, URL: <https://www.nmr.mgh.harvard.edu/~reese/electrolytics/>, >, 6 pages.

YouTube video "AmRad's Turbo Installation" published on Apr. 22, 2012 by AmRad Engineering {link: <https://www.youtube.com/watch?v=axo86NCbuNs&lc=UgguTwZgduBg5HgCoAEC>}, 6 pages.

YouTube video "HVAC 1 AC Repairs 1 Turbo 200 Capacitor Install 1 Crest Hill, IL 1 2" published on Jul. 15, 2011 by NLB Heating & Cooling hereafter referred to as NLB {link to video: <https://www.youtube.com/watch?v=U7h7pg12t6M>}, 5 pages.

"AC Capacitors," brochure by AmRad Engineering, Inc., undated (4 pages).

"American Radionic Co., Inc. Introduces . . . The World's First Multiple Metallized Film Dielectric Capacitor Produced from a Single Winding! The Patented Ultramet™ Capacitor," poster by American Radionic Co., Inc. (undated) (one page).

"Industrial Power Factor Correction Capacitors," Cornell Dubilier, Undated (1 page).

"The Patented Ultramet™ Capacitor," poster by American Radionic Co., Inc., (undated) (three pages).

"The Patented Ultramet™ Capacitor. A product of years of American Radionic research & development," poster by American Radionic Co., Inc. (undated) (one page).

Photograph 1 from Defendants' First Supplemental Disclosure of Non-Infringement and Invalidity Contentions, undated (1 page).

Photograph 10, undated (1 page).

Photograph 11, undated (1 page).

Photograph 12, undated (1 page).

Photograph 13, undated (1 page).

Photograph 14, undated (1 page).

Photograph 15, undated (1 page).

Photograph 16, undated (1 page).

Photograph 17, undated (1 page).

Photograph 18, undated (1 page).

Photograph 19, undated (1 page).

Photograph 2 from Defendants' First Supplemental Disclosure of Non-Infringement and Invalidity Contentions, undated (1 page).

Photograph 20, undated (1 page).

Photograph 3 from Defendants' First Supplemental Disclosure of Non-Infringement and Invalidity Contentions, undated (1 page).

Photograph 4 from Defendants' First Supplemental Disclosure of Non-Infringement and Invalidity Contentions, undated (1 page).

Photograph 5 from Defendants' First Supplemental Disclosure of Non-Infringement and Invalidity Contentions, undated (1 page).

Photograph 6 from Defendants' First Supplemental Disclosure of Non-Infringement and Invalidity Contentions, undated (1 page).

Photograph 7 from Defendants' First Supplemental Disclosure of Non-Infringement and Invalidity Contentions, undated (1 page).

Photograph 8, undated (1 page).

Photograph 9, undated (1 page).

"American Radionics—Home of the Turbo200 MultiUse Capacitor," online archive of website captured at [http://web.archive.org/web/20050309191805fw\\_/http://www.americanradionic.com/home](http://web.archive.org/web/20050309191805fw_/http://www.americanradionic.com/home), Mar. 9, 2005, (16 pages), (accessed May 29, 2014).

"American Radionic Co., Inc. Introduces A New Circuit Component The Patented Ultramet™ Capacitor," poster by American Radionic Co., Inc., (poster undated, 1980 year date appears below one image), (one page).

"American Radionic Co., Inc. Introduces A New Circuit Component, The Patented Ultramet™ Capacitor," poster by American Radionic Co., Inc., which is reprint from Electronic News dated Feb. 11, 1980, (one page).

"American Radionic Company's Chronology of Patents, New Products and Technology Transfer Programs—From the Present, to the Past, a Thirty-Five Year Review," online website having URL: <http://www.americanradionic.com/content/blogcategory/13/29/8/16>, accessed May 19, 2014 (undated) (3 pages).

"American Radionic Introduces Capacitors Without Compromise", color brochure, 1989, (1 page).

"AmRad Engineering|Universal Capacitor," The Air Conditioning|Heating|Refrigeration News, Jan. 29, 2005, Printout of website having URL: <http://www.archnews.com/articles/print/amrad-engineering-universal-capacitor>" (accessed Jun. 2, 2014) (1 page).

"Capacitors—Motor Run, Oil Filled Capacitors, AC Rated. AmRad." Online archive of website captured at <http://web.archive.org/web/20041214091042/http://www.americanradionic.com>, Dec. 14, 2004, (13 pages) (accessed May 29, 2014).

"Capacitors—Motor Run, Oil Filled Capacitors, AC Rated. AmRad." Online archive of website captured at <http://web.archive.org/web/20011126195819/http://www.americanradionic.com>, Nov. 26, 2001, (13 pages) (accessed May 29, 2014).

"Capacitors—Motor Run, Oil Filled Capacitors, AC Rated. AmRad." Printout of website having URL: <http://amradcapacitors.com/index.htm>, Jan. 3, 2003(20 pages).

"Product of the Year Awards," Electronic Products Magazine, Jan. 1981, pp. 39-45.

"Super-Sized Show," ASHRAe Journal Show Daily, 2005 International Air-Conditioning, Heating, Refrigerating Exposition, Tuesday, Feb. 8, 2005 (24 pages).

Amazon. [https://www.amazon.com/TEMCo-Capacitor-RC0120-50-Electric-Motor/dp/B01H0S87X6/ref+pd\\_sim\\_328\\_5](https://www.amazon.com/TEMCo-Capacitor-RC0120-50-Electric-Motor/dp/B01H0S87X6/ref+pd_sim_328_5) Aug. 29,

2014. TEMCo Dual Run Capacitor RC0120-50/5 nffd 370 V 440 V Vac volt 50+5 uf AC Electric Motor HVAC, 6 pages.

Amazon. <URL: [https://www.amazon.com/AmRad-Turbo-200-Mini-Oval/dp/BOOKQSKDOY/ref=pd\\_sbs\\_60\\_4?\\_encoding=UTF8&pd\\_rd\\_i=BOOKQSKDOY&pd\\_rd\\_r=A6%0E2%080%0A6](https://www.amazon.com/AmRad-Turbo-200-Mini-Oval/dp/BOOKQSKDOY/ref=pd_sbs_60_4?_encoding=UTF8&pd_rd_i=BOOKQSKDOY&pd_rd_r=A6%0E2%080%0A6)> May 5, 2015. AmRad Turbo 200 Mini Oval Capacitor with label and color trim, 5 pages.

Amazon. <URL: [https://www.amazon.com/Amrad-Turbo-Universal-Motor-Capacitor/dp/B00B610TOM/ref=pd\\_rhf\\_dp\\_s\\_cp\\_0\\_7?\\_encoding=UTF8&pd\\_rd\\_i=B00B610TOM&pd\\_rd\\_r=N5WYCAD5Y36C86DFWDEG&pd\\_rd\\_w=6tW71&pd\\_rd\\_wg=DWEJcApsc=1&refRID=N5WYCAD5Y36C86DFWDEG](https://www.amazon.com/Amrad-Turbo-Universal-Motor-Capacitor/dp/B00B610TOM/ref=pd_rhf_dp_s_cp_0_7?_encoding=UTF8&pd_rd_i=B00B610TOM&pd_rd_r=N5WYCAD5Y36C86DFWDEG&pd_rd_w=6tW71&pd_rd_wg=DWEJcApsc=1&refRID=N5WYCAD5Y36C86DFWDEG)> Jan. 27, 2013. Amrad Turbo 200X Universal Motor Run Capacitor.

Amazon. <URL: [https://www.amazon.com/AmRad-USA2227-MFD-370-Volt/dp/BOOGSU3YV8/ref=pd\\_day0\\_328\\_6?\\_encoding=UTF8&pd\\_rd\\_i=BOOGSU3YV8&pd\\_rd\\_r%0E2%080%0A6](https://www.amazon.com/AmRad-USA2227-MFD-370-Volt/dp/BOOGSU3YV8/ref=pd_day0_328_6?_encoding=UTF8&pd_rd_i=BOOGSU3YV8&pd_rd_r%0E2%080%0A6)> Jun. 29, 2014. AmRad Dual Run Capacitor, 6 pages.

Amazon. <URL: [https://www.amazon.com/CPT00656-Trane-Round-Capacitor-Upgrade/dp/BOOEVTIOMC/ref=cm\\_cr\\_ar\\_p\\_d\\_product\\_top?ie=UTF8](https://www.amazon.com/CPT00656-Trane-Round-Capacitor-Upgrade/dp/BOOEVTIOMC/ref=cm_cr_ar_p_d_product_top?ie=UTF8)> May 11, 2016. Replacement Trane Round Dual Run Capacitor, 6 pages.

Amazon. <URL: [https://www.amazon.com/gp/product/B01HPK5ANO/ref=s9\\_dcacs\\_dcoop\\_bw\\_c\\_x\\_6\\_w](https://www.amazon.com/gp/product/B01HPK5ANO/ref=s9_dcacs_dcoop_bw_c_x_6_w)> Aug. 21, 2016. Titan TRCFD405 Dual Rated Motor Run Capacitor, 6 pages.

Amazon. <URL: [https://www.amazon.com/Labels-Protective-Backed-Clean-Remove-Adhesive/dp/BOOVIDW1C1/ref=sr\\_1\\_18?ie=UTF8&clid=1522957818&sr=8-18&keycY0E2%080%0A6](https://www.amazon.com/Labels-Protective-Backed-Clean-Remove-Adhesive/dp/BOOVIDW1C1/ref=sr_1_18?ie=UTF8&clid=1522957818&sr=8-18&keycY0E2%080%0A6)> Apr. 1, 2015. Labels, 7 pages.

Amazon. <URL: [https://www.amazon.com/MARS-Motors-Armatures-12788-Capacitor/dp/BOOCOYS2CM/ref=pd\\_sim\\_328\\_6?\\_encoding=UTF8&pd\\_rd\\_i=BOOCOYS2CM&pd\\_rd\\_r=KEFT1DXGOAWQIKCZDJFJ&pd\\_rd\\_w=LNF6S&pd\\_rd\\_wg=5eFTh&psc=1&refRID=KEFT1DXGOAWQIKCZDJFJ](https://www.amazon.com/MARS-Motors-Armatures-12788-Capacitor/dp/BOOCOYS2CM/ref=pd_sim_328_6?_encoding=UTF8&pd_rd_i=BOOCOYS2CM&pd_rd_r=KEFT1DXGOAWQIKCZDJFJ&pd_rd_w=LNF6S&pd_rd_wg=5eFTh&psc=1&refRID=KEFT1DXGOAWQIKCZDJFJ)> Jan. 25, 2012. Mars Dual Run Capacitor, 7 pages.

Amazon. <URL: [https://www.amazon.com/Universal-Capacitor-Trane-Replacement-USA2031/dp/BOOGSU4OKW/ref=pd\\_sim\\_328\\_3?\\_encoding=UTF8&pd\\_rd\\_i=BOOGSU4OKW&pd\\_rd\\_r=YX6P84XR7NY113X4DWJG&pd\\_rd\\_w=gejaD&pd\\_rd\\_wg=NLVYI&psc=1&refRID=YX6P84XR7NY113X4DWJG](https://www.amazon.com/Universal-Capacitor-Trane-Replacement-USA2031/dp/BOOGSU4OKW/ref=pd_sim_328_3?_encoding=UTF8&pd_rd_i=BOOGSU4OKW&pd_rd_r=YX6P84XR7NY113X4DWJG&pd_rd_w=gejaD&pd_rd_wg=NLVYI&psc=1&refRID=YX6P84XR7NY113X4DWJG)> Nov. 26, 2014. Am Rad Oval Universal Capacitor with label and color trim, 6 pages.

Amazon. <URL: [https://www.amazon.com/dp/B00FL70C0U/ref=cm\\_sw\\_r\\_cp\\_ep\\_dp\\_qIIZBbFD278ZE](https://www.amazon.com/dp/B00FL70C0U/ref=cm_sw_r_cp_ep_dp_qIIZBbFD278ZE)> Dec. 4, 2013. Amrad Engineering USA2215 Round Motor Run Capacitor, 40 MFD, 370\_440 Vac—Pipe Fittings, 6 pages.

Amazon. Link: [https://www.amazon.com/Round-Universal-Capacitor-Replacement-USA2235/dp/BOOGSU4401/ref=cnn\\_cr\\_ar\\_p\\_d\\_product\\_top?ie=UTF8](https://www.amazon.com/Round-Universal-Capacitor-Replacement-USA2235/dp/BOOGSU4401/ref=cnn_cr_ar_p_d_product_top?ie=UTF8). Jun. 20, 2014. Round Dual Universal Capacitor. (Year: 2014), 6 pages.

EdisonTechcenter. Link: <http://edisontechcenter.org/batteries.html#drycell>. 2014. Bright Star 1.5 V Columbia dry cell. (Year: 2014), 10 pages.

Eveready. Link: <http://www.eveready.com/about-us/battery-history>. Visited Nov. 30, 2018. 1950s Eveready Battery. (Year: 2018), 2 pages.

Response to Plaintiff's Claim Construction Brief re 60 Brief—Plaintiff filed by Cornell-Dubliner Electronics, Inc., Packard Inc. (Killen, Craig) Modified on Jul. 17, 2015 (EJS). (Entered Jul. 16, 2015).

Wikimedia Commons. Link: <https://connnons.wikimedia.org/wiki/File:PP4-PP3-batteries.jpg>. Oct. 22, 2016. Eveready PP4 battery. (Year: 2016), 17 pages.

YouTube. <URL: <https://www.youtube.com/watch?v=19A9IvQ611A&t=3s>> Oct. 1, 2015. GE Dual Run Capacitor, 5 pages.

YouTube. <URL: <https://www.youtube.com/watch?v=R5B189BWz0>> Jul. 29, 2011. HVAC Service: Install New Turbo 200 Capacitor.

Amazon.com [online], “BlueStars—Hard Start Capacitor,” Aug. 29, 2019, retrieved on May 17, 2023, retrieved from URL <<https://www.amazon.co.uk/dp/B07X463KD1/>>, 1 page.

Amradmanufacturing.com [online], “AmRad—Turbo Easy-Start 5,” available on or before Sep. 22, 2020, retrieved on May 16, 2023, retrieved from URL <<https://amradmanufacturing.com/products/turbo-easy-start-5/>>, 14 pages.

Orbit.com [online], “Capacitor and relays. (Design -@Questel),” [Online PDF compilation of references selected by examiner], date ranges Dec. 1, 2004-Oct. 23, 2020, retrieved on May 24, 2023, retrieved from URL <[https://www.orbit.com/export/UCZAH96B/pdf4/flfd9e1\\_a-5fbf\\_46a1-a7a3-a0df0b968f4a-160819.pdf](https://www.orbit.com/export/UCZAH96B/pdf4/flfd9e1_a-5fbf_46a1-a7a3-a0df0b968f4a-160819.pdf)>, 18 pages.

Supplyhouse.com [online], “23-208 MFD Turbolytic JR Universal Replacement Capacitor (125-330V),” available on or before Apr. 5, 2016, retrieved on Jul. 27, 2023, retrieved from URL <<https://www.supplyhouse.com/MARS-11100-23-208-MFD-Turbolytic-JR-Universal-Replacement-Capacitor-125-330V>>, 4 pages.

Amazon.com [online], “Packard TRCFB405 40+5MFD/440/370VAC/RND Capacitor,” May 1, 2015, retrieved on Apr. 26, 2018, retrieved from <URL: [https://www.amazon.com/Packard-TRCFD405-5MFD-370VACCapacitor/dp/B009558E9U/ref=pd\\_sim\\_328\\_4?\\_encoding=UTF8&pd\\_rd\\_i=B009558E9U&pd\\_rd\\_r= SXIDRWZQZ8SH12JWHYH2&pd\\_rd\\_w=yIjQe&pd\\_rd\\_wg=mH0n1&psc=1&refRID= SXIDRWZQZ8SH12JWHYH2&dpID=31IxzeyCr/0252B7L&preST=\\_QL70&dpSrc=detail](https://www.amazon.com/Packard-TRCFD405-5MFD-370VACCapacitor/dp/B009558E9U/ref=pd_sim_328_4?_encoding=UTF8&pd_rd_i=B009558E9U&pd_rd_r= SXIDRWZQZ8SH12JWHYH2&pd_rd_w=yIjQe&pd_rd_wg=mH0n1&psc=1&refRID= SXIDRWZQZ8SH12JWHYH2&dpID=31IxzeyCr/0252B7L&preST=_QL70&dpSrc=detail)>, 5 pages.

Amazon.com [online], “PowerWell 35+5 uf MFD 370 or 440 Volt Dual Rub Round Capacitor Kit TP-CAP-35/5/440R Condenser Straight Cool/Heat Pump Air Conditioner and Zip Tie,” Aug. 1, 2016, retired on Apr. 6, 2018, retrieved from <URL: [https://www.amazon.com/dp/B01F7P8GJO/ref=spsa\\_dk\\_detail\\_4?psc=1](https://www.amazon.com/dp/B01F7P8GJO/ref=spsa_dk_detail_4?psc=1)>, 6 pages. Answer and affirmative defenses to Complaint by Cornell-Dubliner Electronics, Inc. (Allaman, Melissa) (Entered: Jan. 9, 2015), 10 pages.

Answer and affirmative defenses to Complaint by Packard Inc. (Allaman, Melissa) (Entered: Jan. 9, 2015), 10 pages.

Case Management and Scheduling Order: Amended Pleadings and Joinder of Parties due by Apr. 9, 2015. Discovery due by Feb. 16, 2016. Dispositive motions due by Apr. 7, 2016. Pretrial statement due by Aug. 11, 2016. All other motions due by Jul. 28, 2016. Plaintiff disclosure of expert report due by Dec. 10, 2015. Defendant disclosure of expert report due by Jan. 14, 2016. Final Pretrial Conference set for Aug. 18, 2016 at 01:15 PM in Orlando Courtroom 4 A before Judge Roy B. Dalton, Jr., Jury Trial Set for the trial team commencing Sep. 6, 2016 at 09:00 AM in Orlando Courtroom 4 A before Judge Roy B. Dalton Jr., Conduct mediation hearing by Mar. 29, 2016. Lead counsel to coordinate dates. Signed by Judge Roy B. Dalton, Jr. on Feb. 10, 2015. (VMF). (Entered: Feb. 10, 2015), 23 pages.

Complaint for Patent Infringement against Cornell-Dubliner Electronics, Inc., Packard Inc. with Jury Demand (Filing fee \$400 receipt No. ORL-38930) filed by American Radionic Company, Inc. (Attachments: #1 Civil Cover sheet, #2 Exhibit A)(LMM) Modified on Nov. 19, 2014 (LMM). (Entered: Nov. 19, 2014), 47 pages.

Declaration of Noah C. Graubart in Support of Plaintiff's Claim Construction Brief by American Radionic Company, Inc. (Attachments: #1 Exhibit 1, #2 Exhibit 2, #3 Exhibit 3, #4 Exhibit 4, #5 Exhibit 5, #6 Exhibit 6) (Graubart, Noah) (Entered: Jun. 18, 2015), 250 pages.

Defendants' First Supplemental Disclosure of Non-Infringement and Invalidity Contentions *American Radionic, Inc., v. Packard, Inc., and Cornell-Dubilier Electronics, Inc.*, No. 6:14-cv-01881-RBD-KRS, 26 pages.

Document from Defendants' First Supplemental Disclosure of Non-Infringement and Invalidity Contentions that purported to be Standard for Safety UL 810 Capacitors, Underwriters Laboratories Inc. having multiple dates ranging from 1976 to 1988 (22 pages). First Amended Answer and affirmative defenses to 1 Complaint by Cornell-Dubliner Electronics, Inc. (Allaman, Melissa) (Entered: Feb. 4, 2015), 17 pages.

First Amended Answer and affirmative defenses to 1 Complaint by Packard Inc. (Allaman, Melissa) (Entered: Jan. 9, 2015), 17 pages. Grainger, “Round Motor Dual Run Capacitor, 40/5 Microfarad Rating, 370VAC Voltage,” 2017, retrieved on Aug. 24, 2017, Retrieved from the Internet: URL <[https://www.grainger.com/product/5CMW3&AL!2966!3!166587674359 !!!g!8 2128730437 !?cm\\_mmc-PPC:+Google+PLA?campaignid=719691765&s\\_kwcid=AL!2966!3!166587674359 !!!82128730437!&ef\\_id=WR5nXQAAAILWhR1b:20170824174108:s](https://www.grainger.com/product/5CMW3&AL!2966!3!166587674359 !!!g!8 2128730437 !?cm_mmc-PPC:+Google+PLA?campaignid=719691765&s_kwcid=AL!2966!3!166587674359 !!!82128730437!&ef_id=WR5nXQAAAILWhR1b:20170824174108:s)>, 5 pages.

Hudis, Martin et al., "Motor-Run Capacitors," *Motors & Motor Control*, undated (reprinted from *Appliance Manufacturer*, Oct. 1994) (3 pages).

Hudis, Martin, "Plastic Case Self-Protected Liquid Filled AC Capacitors for 70° Applications," Presented at CAPTECH '97, Mar. 1997, 7 pages.

Hudis, Martin, "Technology Evolution in Metallized Polymeric Film Capacitors over the Past 10 Years," Presented at CARTS Symposium in Nice, France, Oct. 1996, 9 pages.

International Search Report and Written Opinion, PCT/US2014/39003, Oct. 2, 2014, 12 pages.

Joint Pre-Hearing Statement re: Claim Construction by American Radionic Company, Inc., Packard Inc., Cornell-Dubliner Electronics, Inc. (Attachments: #1 Exhibit 1, #2 Exhibit 2) (Graubart, Noah) Modified on Jul. 24, 2015, 6 pages.

Macomber, Laird L., et al., "New Solid Polymer Aluminum Capacitors Improve Reliability," *Electro Power Electronics*, Oct. 1, 2001, 5 pages.

Macomber, Laird L., et al., "Solid Polymer Aluminum Capacitor Chips in DC-DC Converter Modules Reduce Cost and Size and Improve High-Frequency Performance," PCIM Power Electronics 2001 Proceeding for the PowerSystems World Conference, Sep. 2001, 8 pages.

Mallory Distributor Products Co., 1967 Precision Electronic Components Catalog, 52 pages.

Minute Entry, Proceedings of Claim Construction Hearing held before Judge Roy B. Dalton, Jr. on Aug. 24, 2015. Court Report: Arnie First (VMF) (FMV). (Entered: Aug. 24, 2015), 1 page.

Notice of Filing of Claim Construction Evidence by American Radionic Company, Inc. (Attachments: #1 Exhibit 1, #2 Exhibit 2, #3 Exhibit 3) (Graubart, Noah) Modified on Aug. 25, 2015 (EJS). (Entered: Aug. 25, 2015).

Order granting 69 Motion for Consent Judgment and Injunction, Signed by Judge Roy B. Dalton, Jr. on Nov. 5, 2015. (CAC) (Entered Nov. 5, 2015).

Parente, Audrey, "Can-sized device the right fit," *The Daytona Beach News-Journal*, Jan. 3, 2005 (2 pages).

PCT International Preliminary Report on Patentability in International Appln. No. PCT/US2007/89034, dated Jul. 9, 2009, 6 pages.

PCT International Preliminary Report on Patentability in International Appln. No. PCT/US2014/039003, dated Dec. 3, 2015, 7 pages.

PCT International Preliminary Report on Patentability in International Appln. No. PCT/US2019/068738, dated Jul. 8, 2021, 11 pages.

PCT International Search Report and Written Opinion in International Appln. No. PCT/US2007/89034, dated Apr. 18, 2008, 9 pages.

PCT International Search Report and Written Opinion in International Appln. No. PCT/US2019/068738, dated Mar. 10, 2020 13 pages.

Plaintiff's Brief re 59 Declaration Plaintiff's Claim Construction Brief filed by American Radionic Company, Inc. (Graubart, Noah) (Entered Jun. 18, 2015), 38 pages.

Ruby Lane.com [online], "SuzansTreasures.shop, 1940s Mazon Cobalt Glass Jar Medicine Bottle," 2019, retrieved on Jul. 22, 2019, retrieved from URL <<https://www.rubylane.com/item/34499-CCKx20-x20205/Mazon-Cobalt-Glass-Jar-Medicine-Bottle>>, 3 pages.

Status report Joint Claim Construction Statement by American Radionic Company, Inc., Packard Inc., and Cornell-Dubliner Elec-

tronics, Inc. (Attachments: #1 Exhibit 1, #2 Exhibit 2) (Graubart, Noah) Modified on May 29, 2015 (SWT). (Entered: May 28, 2015), 53 pages.

Transcript of Markman Hearing held on Aug. 24, 15 before Judge Roy B. Dalton, Jr., Court Reporter Arnie R. First, DRD, CRR<ArnieFirst.CourtReporter@gmail.com. Transcript may be viewed at the court public terminal or purchased through the Court Reporter before the deadline for Release of Transcript Restriction. After that date it may be obtained through PACER or purchased through the court Reporter, Redaction Request due Oct. 22, 2015. Redacted Transcript Deadline set for Nov. 2, 2015. Release of Transcript Restriction set for Dec. 30, 2015. (ARF) (Entered: Oct. 1, 2015), 90 pages.

YouTube.com "HVAC Run capacitor Made in the USA," Sep. 4, 2011, retrieved on Apr. 6, 2018, retrieved from <URL: <https://www.youtube.com/watch?v=Xiw xHXJHug.>>, 4 pages.

YouTube.com [online], "How To Install The Turbo 200 Capacitor Pt. 2," Jul. 15, 2011, retrieved on Apr. 11, 2018, retrieved from <URL: <https://www.youtube.com/watch?v=U7h7pgL2t6M.>>, 3 pages.

Albmagnets.com [online], "25 x 10 x 1.5mm Block Magnets | F25x10x1.5mm-AD," available on or before 2023, retrieved on Jul. 24, 2023, retrieved from URL <<https://www.albmagnets.com/block-magnets/2254-25-x-10-x-15mm-block-magnets-f401nasa.html>>, 5 pages.

AnnexGlobal.com [online], "Full Line HVACR Product Catalog," 2018, retrieved on Sep. 4, 2020, retrieved from URL <<https://www.annexglobal.com/innages/SUPCO.pdf>>, 188 pages.

\* cited by examiner

*Primary Examiner* — Lauren D McVey

(74) *Attorney, Agent, or Firm* — Fish & Richardson P.C.

(57)

## CLAIM

The ornamental design for a capacitor, substantially as shown and described.

## DESCRIPTION

FIG. 1 is a front top-left perspective view of a capacitor, showing my new design, taken at line 1 in FIG. 6;

FIG. 2 is a front elevation view thereof, taken at line 2 in FIG. 1;

FIG. 3 is a rear elevation view thereof, taken at line 3 in FIG. 1;

FIG. 4 is a side elevation view thereof, taken at line 4 in FIG. 1;

FIG. 5 is an opposite side elevation view thereof, taken at line 5 in FIG. 1;

FIG. 6 is a top plan view thereof; and,

FIG. 7 is a bottom plan view thereof.

The evenly-spaced broken lines represent unclaimed boundaries and form no part of the claimed design; the dot-dash broken lines in FIGS. 1 and 6 are for reference purposes only.

**1 Claim, 4 Drawing Sheets**

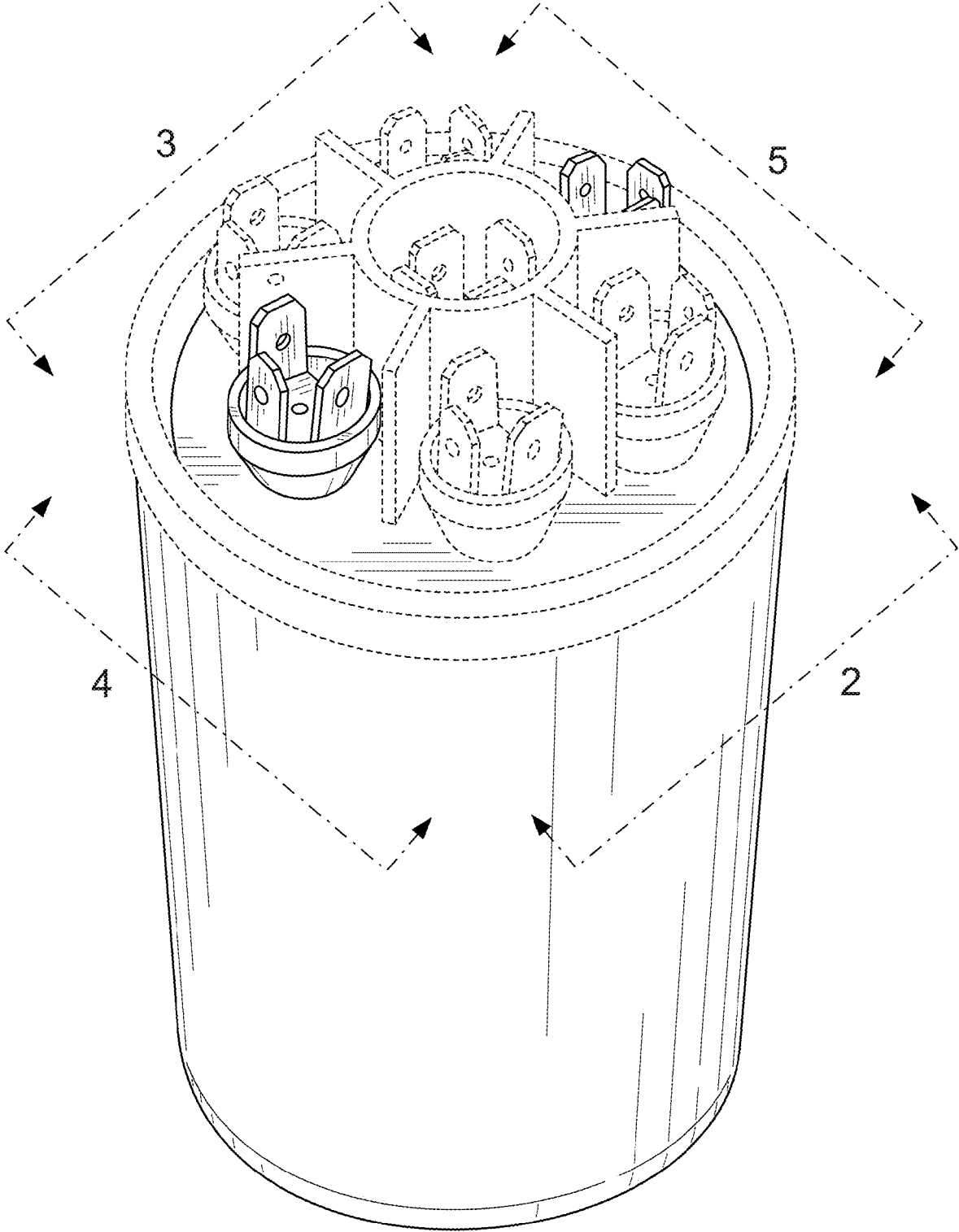

FIG. 1

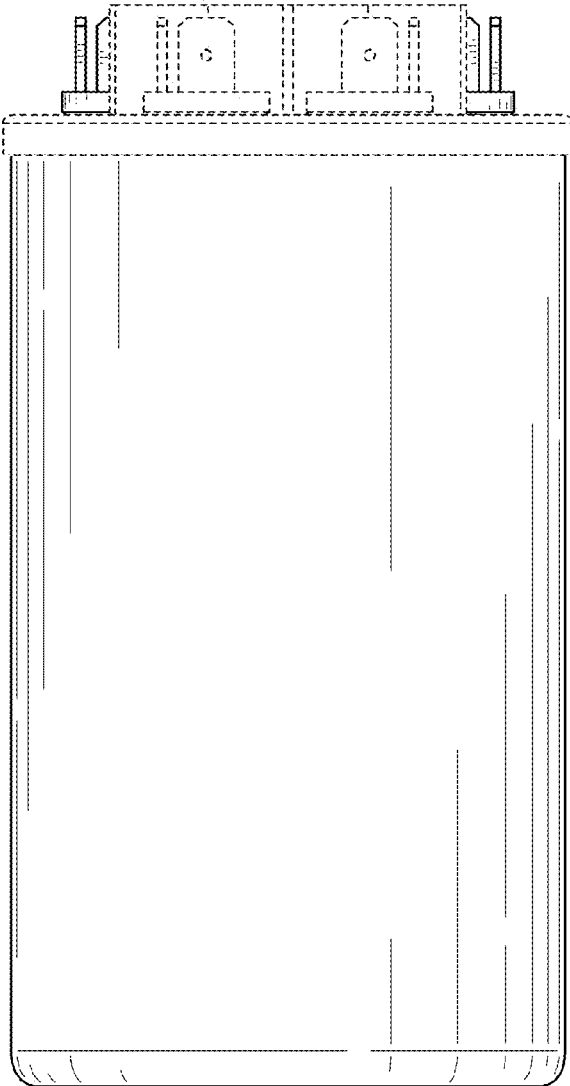

FIG. 2

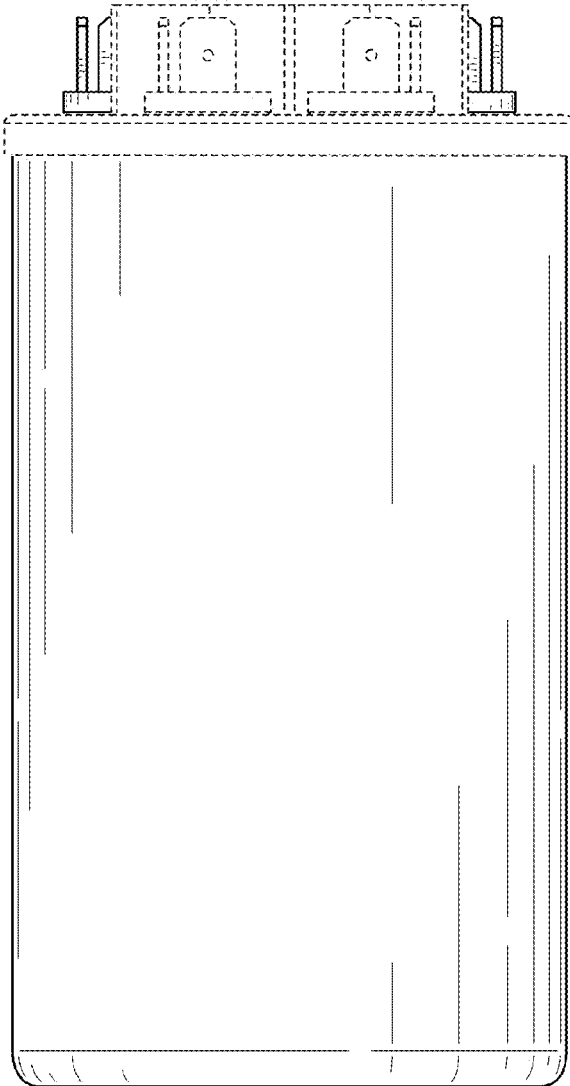

FIG. 3



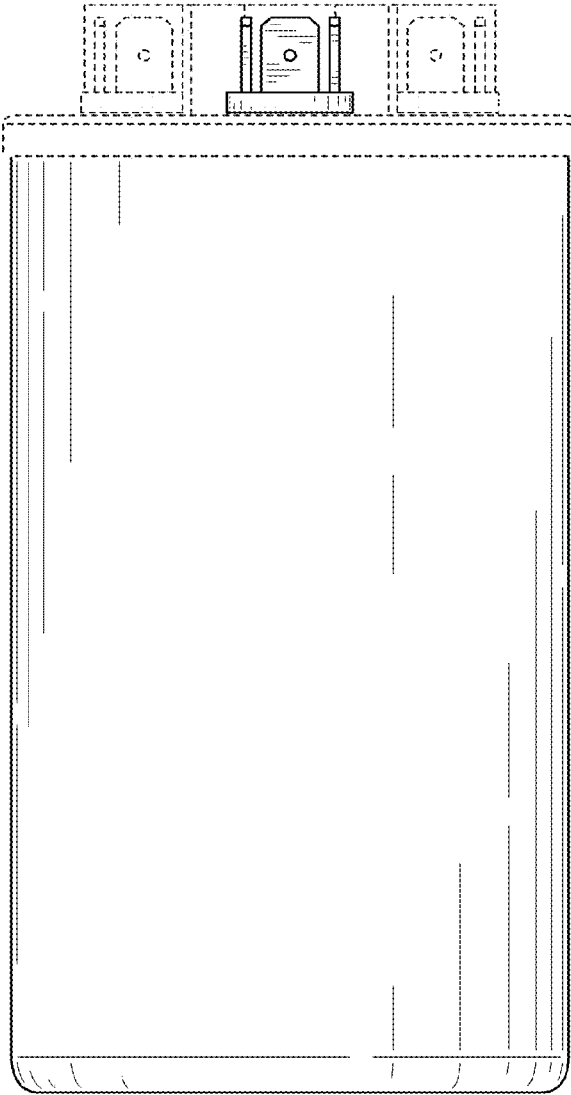

FIG. 4

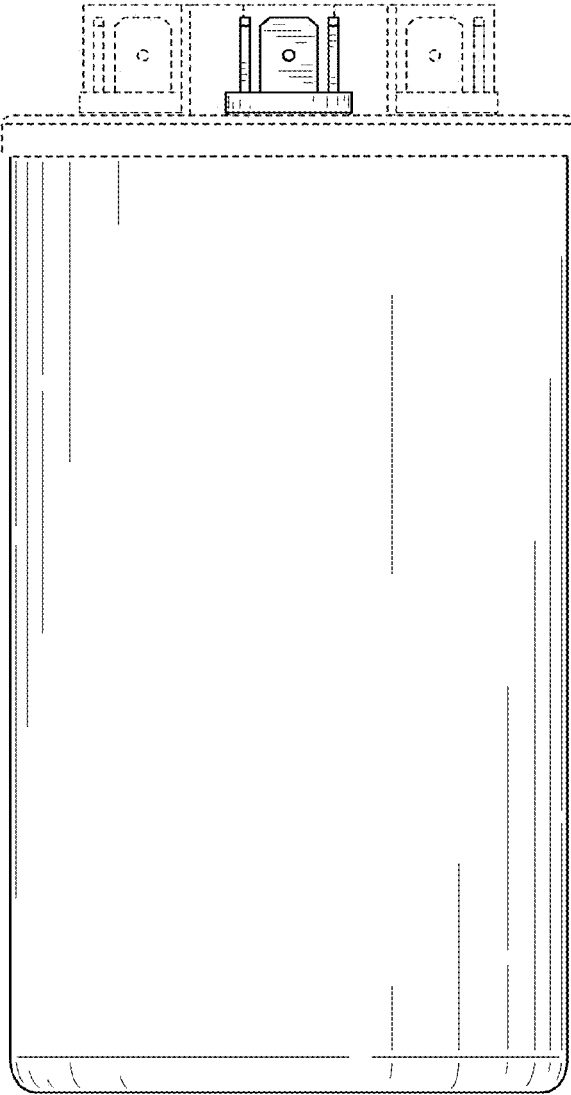

FIG. 5

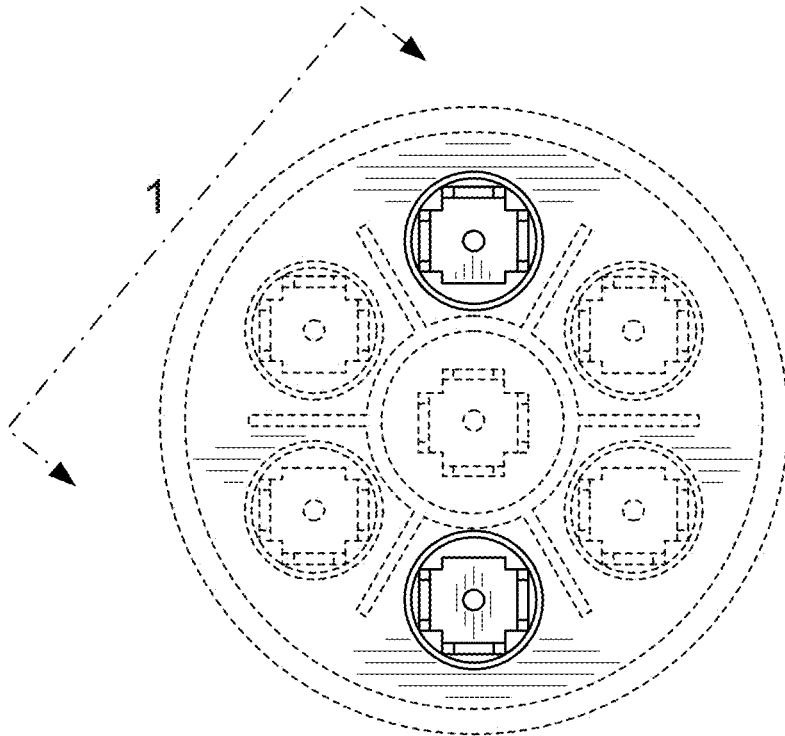

FIG. 6

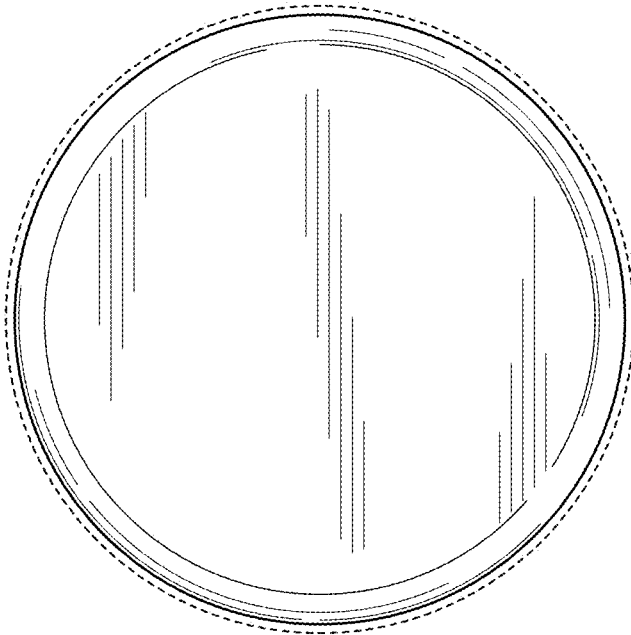

FIG. 7