



US 20120181204A1

(19) **United States**
(12) **Patent Application Publication**
Bogdziewicz, III et al.

(10) **Pub. No.: US 2012/0181204 A1**
(43) **Pub. Date: Jul. 19, 2012**

(54) **PAPER SHELLPAK CONTAINER**

Publication Classification

(75) Inventors: **William J. Bogdziewicz, III,**
Richmond, VA (US); **John A. Gelardi,**
Midlothian, VA (US)

(51) **Int. Cl.**
B65D 5/44 (2006.01)
B65D 77/04 (2006.01)
B65D 75/36 (2006.01)

(73) Assignee: **MEADWESTVACO**
CORPORATION, Richmond, VA
(US)

(52) **U.S. Cl.** **206/468; 206/1.5; 206/784**

(57) **ABSTRACT**

(21) Appl. No.: **13/498,949**

Disclosed is a paperboard container with a top and bottom panel (10, 14), each having side panels (18, 20) that extend the length of either side are folded over and separated by an end panel to form an open ended substantially rectangular box having an interior chamber. A locking apparatus made from plastic is affixed to the top panel. The locking apparatus (32) includes a pair of spaced apart stop pieces (36) and an angled locking post (34). A guide apparatus (38) made from a molded plastic is affixed to the bottom panel. The guide apparatus includes a pair of spaced apart ramps (40). The locking apparatus (32) and the guide apparatus (38) are oriented within the chamber in such a manner as to cooperate to receive and retain at least one substantially flat insert having a cut out area (54) adapted to fit over the angled locking post.

(22) PCT Filed: **Nov. 8, 2010**

(86) PCT No.: **PCT/US10/55821**

§ 371 (c)(1),
(2), (4) Date: **Mar. 29, 2012**

Related U.S. Application Data

(60) Provisional application No. 61/261,814, filed on Nov. 17, 2009.

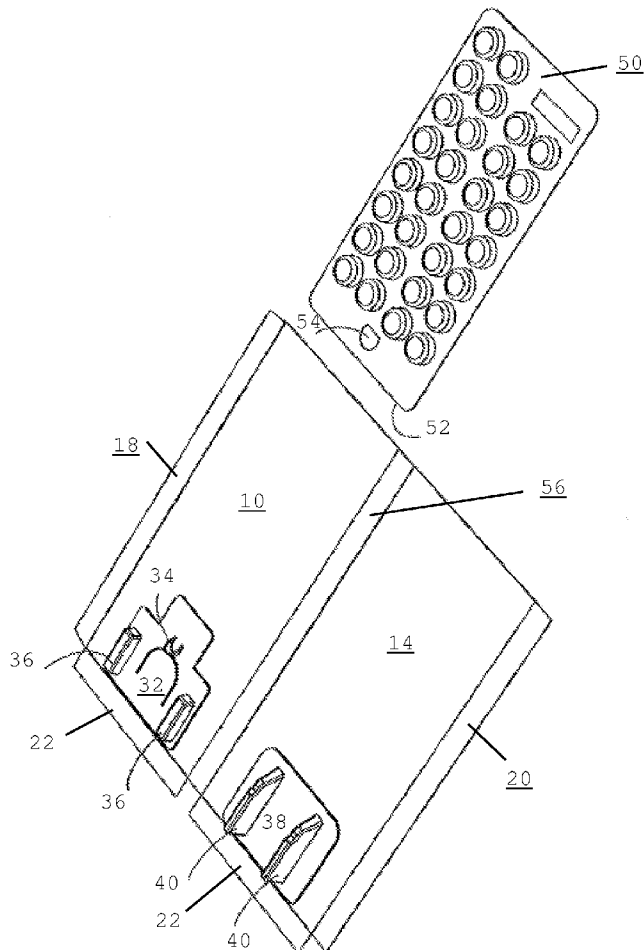

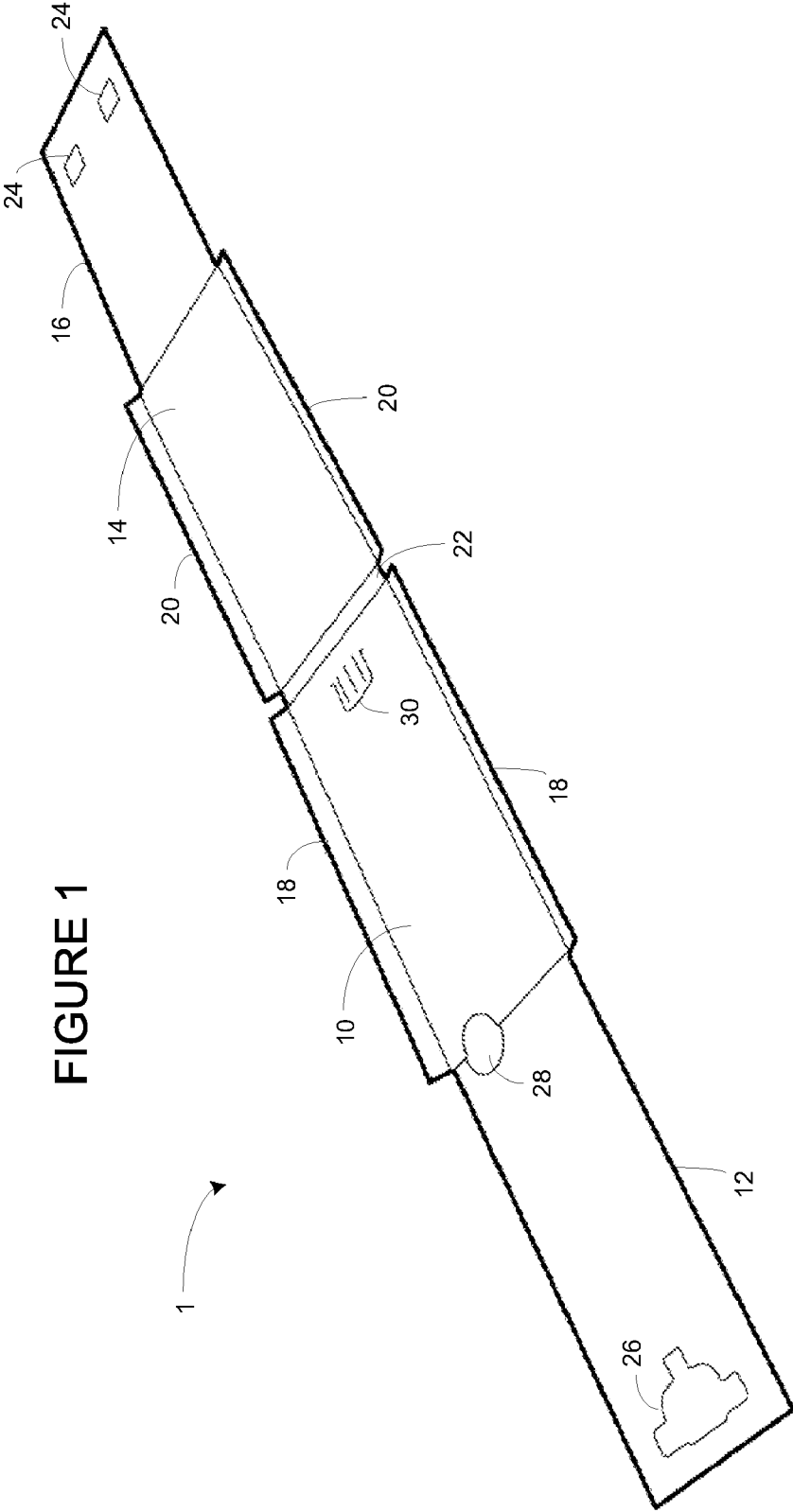

FIGURE 1

FIGURE 2

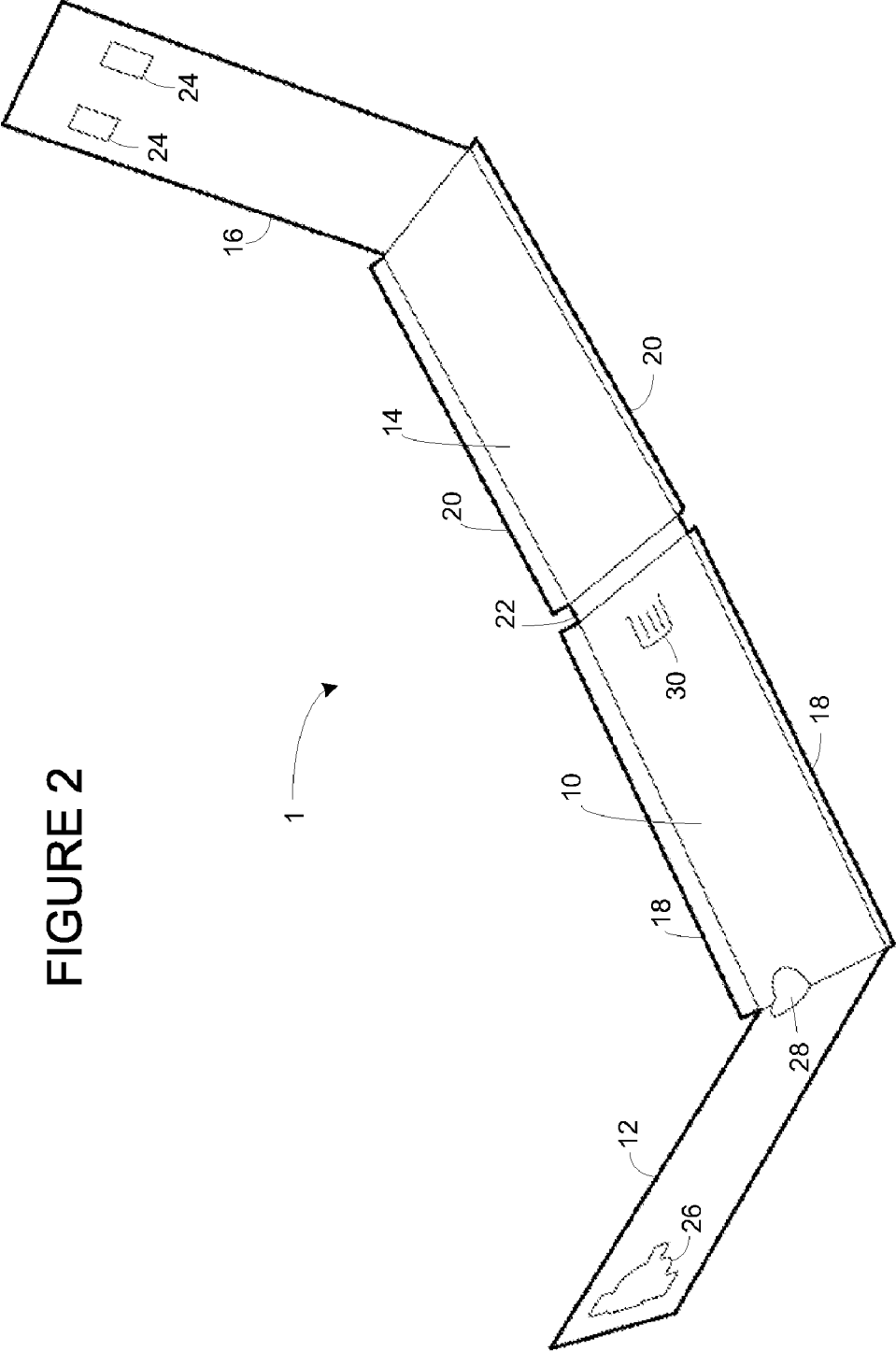

FIGURE 3

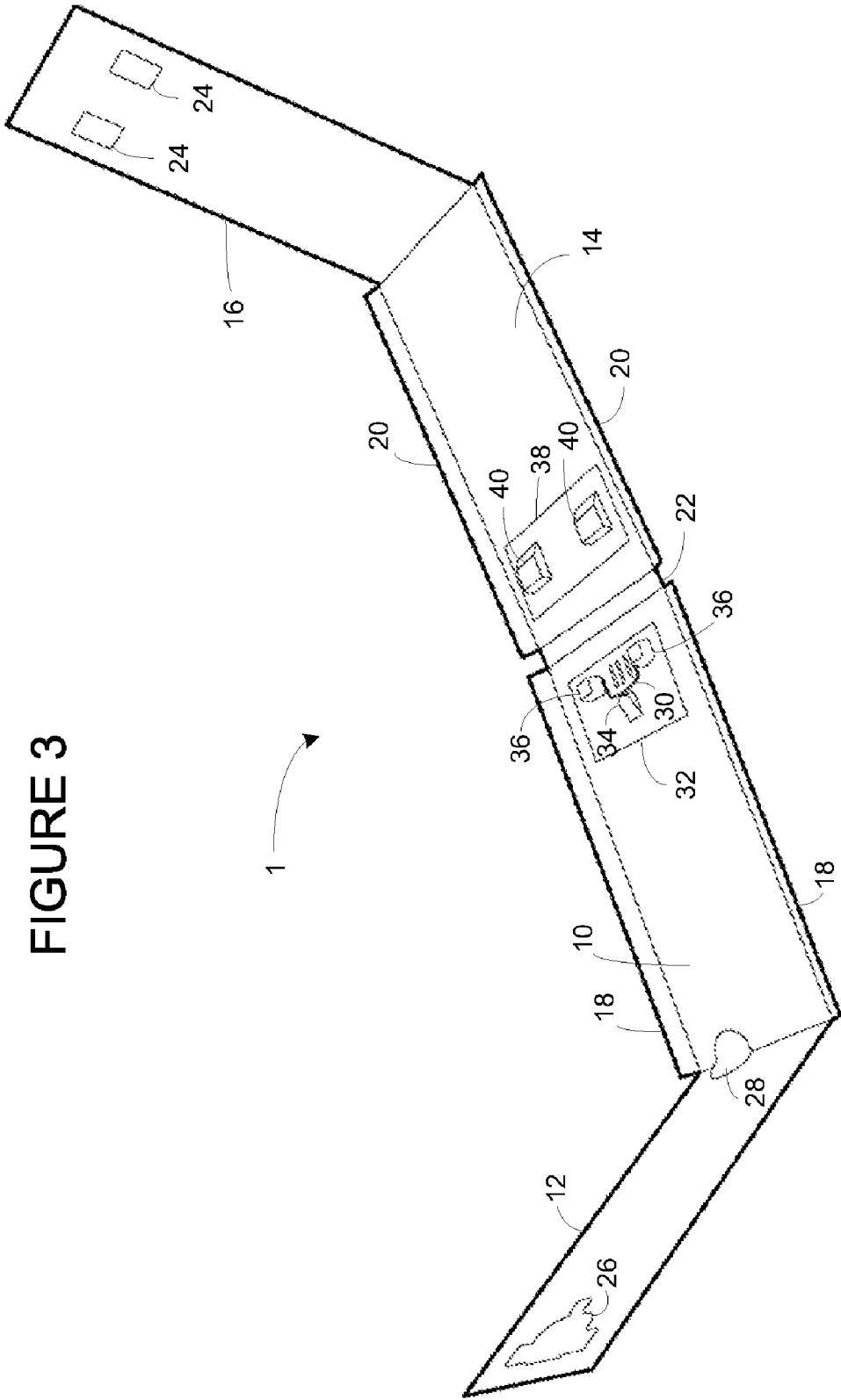

FIGURE 4

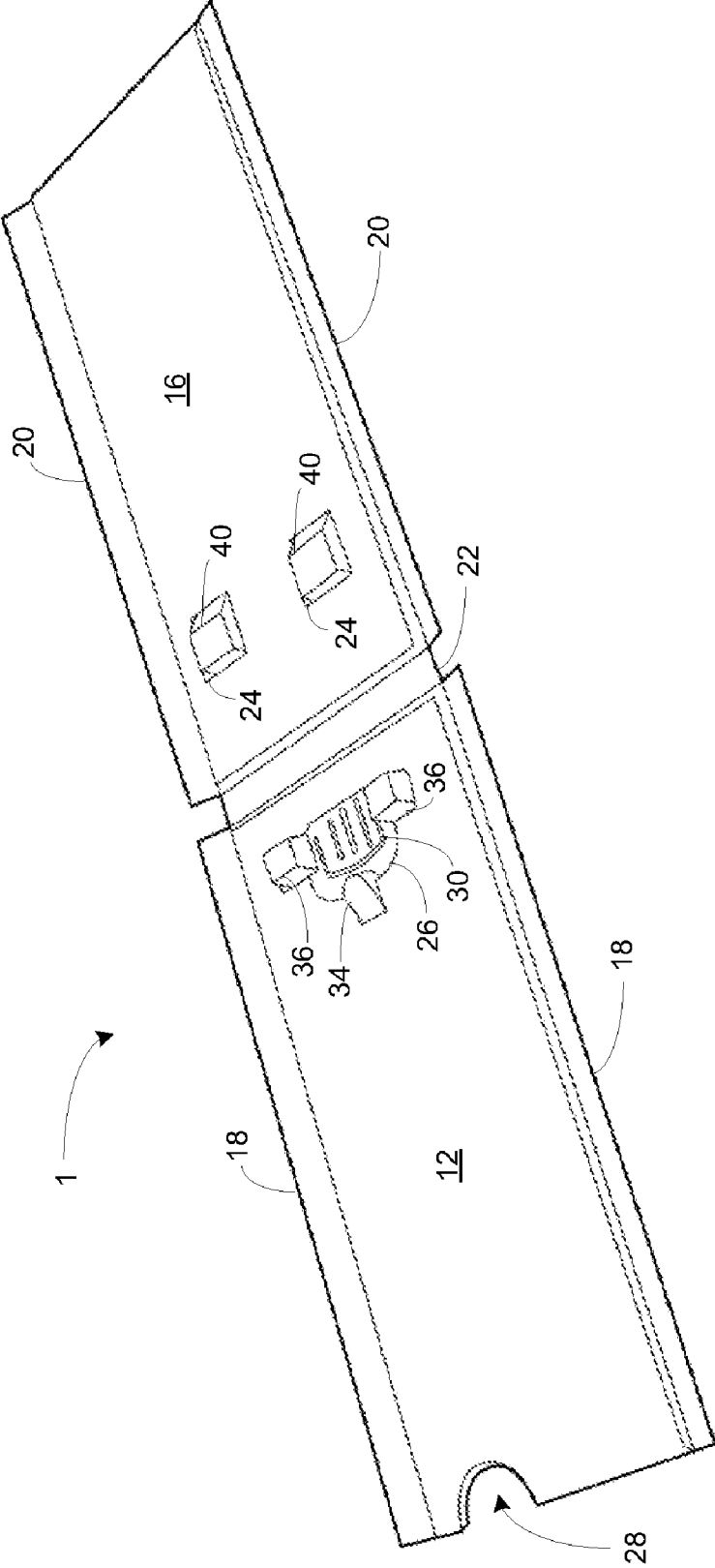

FIGURE 5

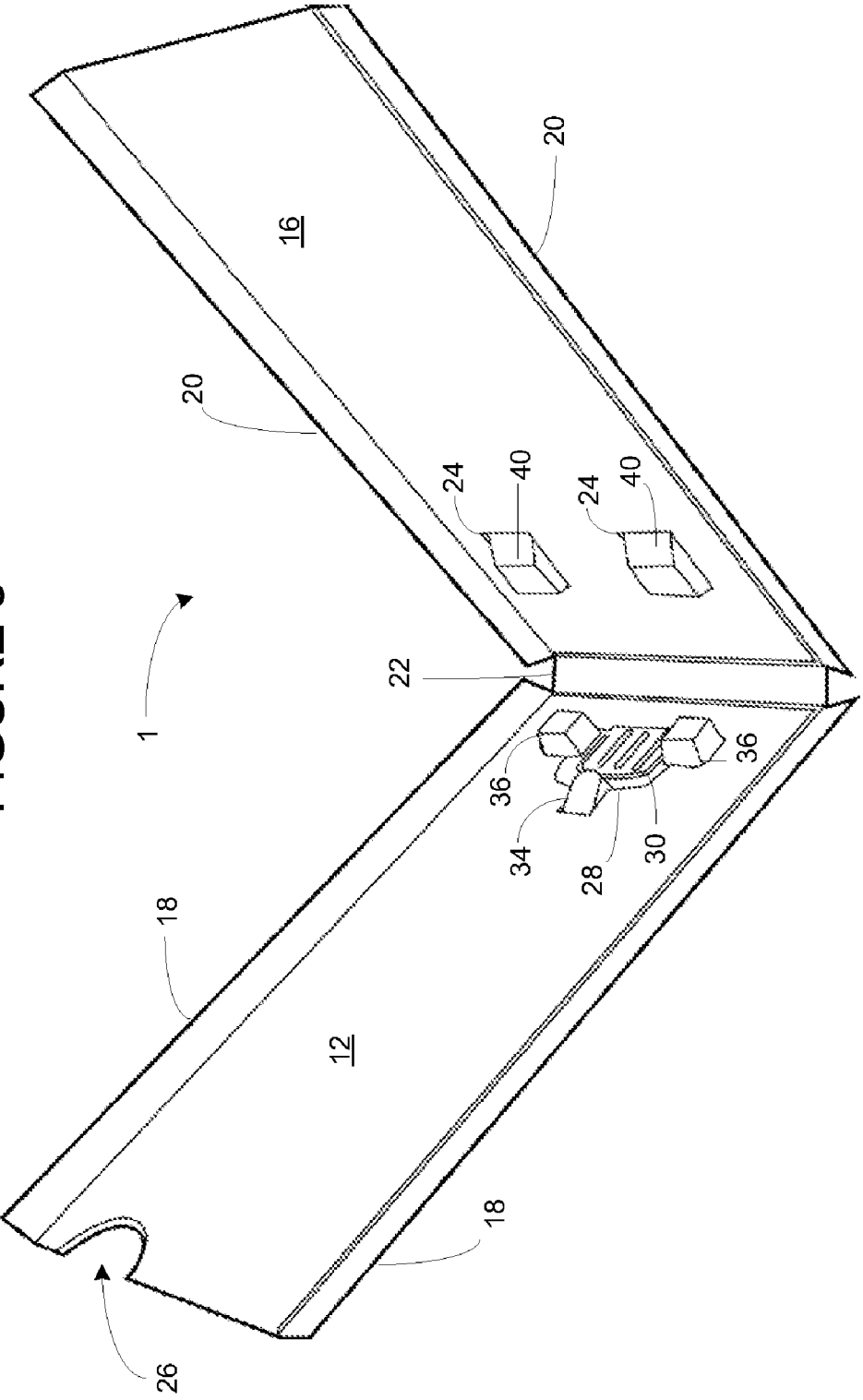

FIGURE 6

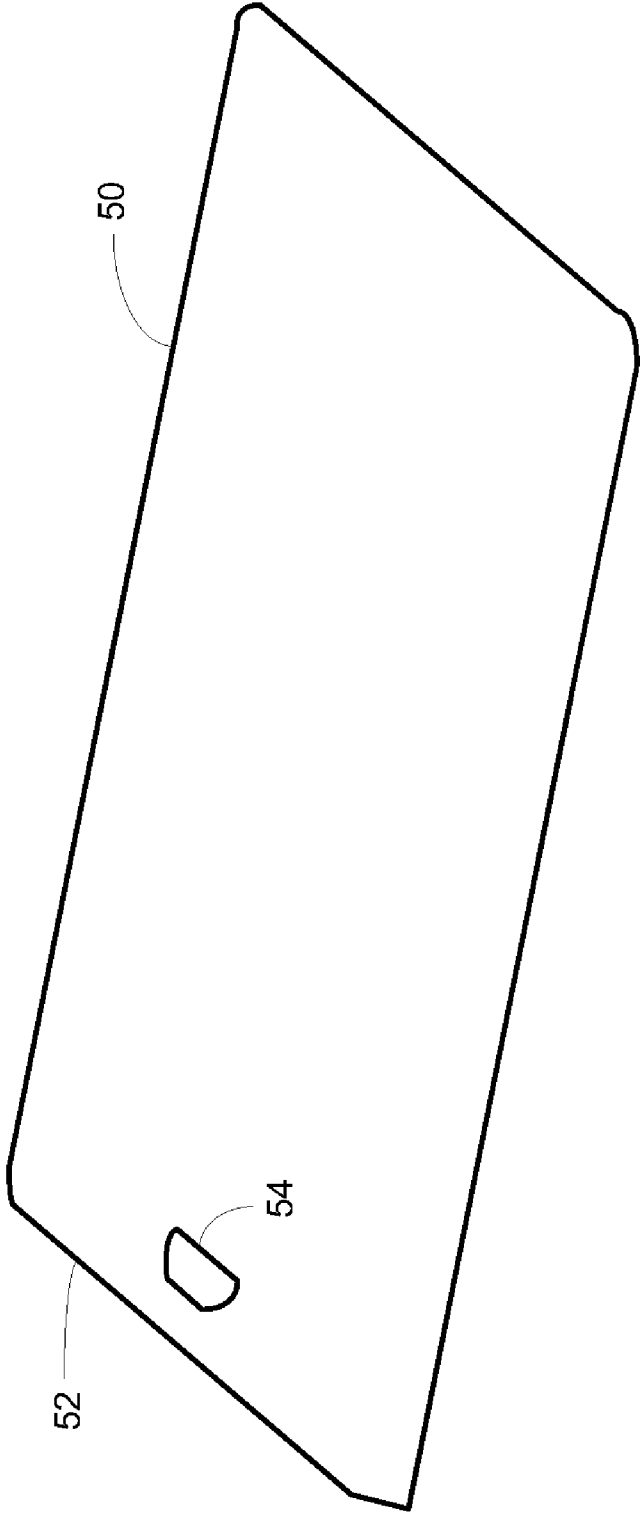
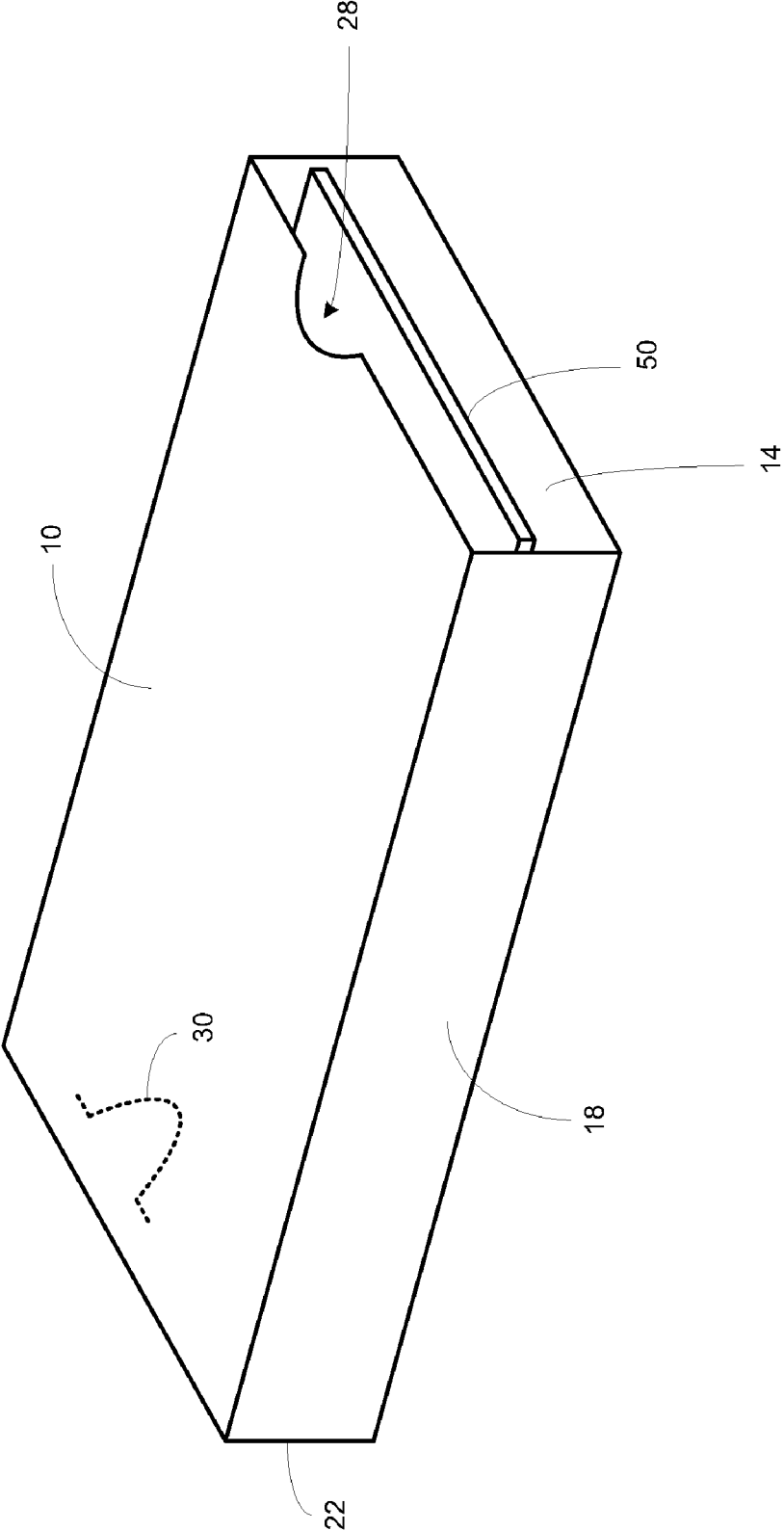

FIGURE 7



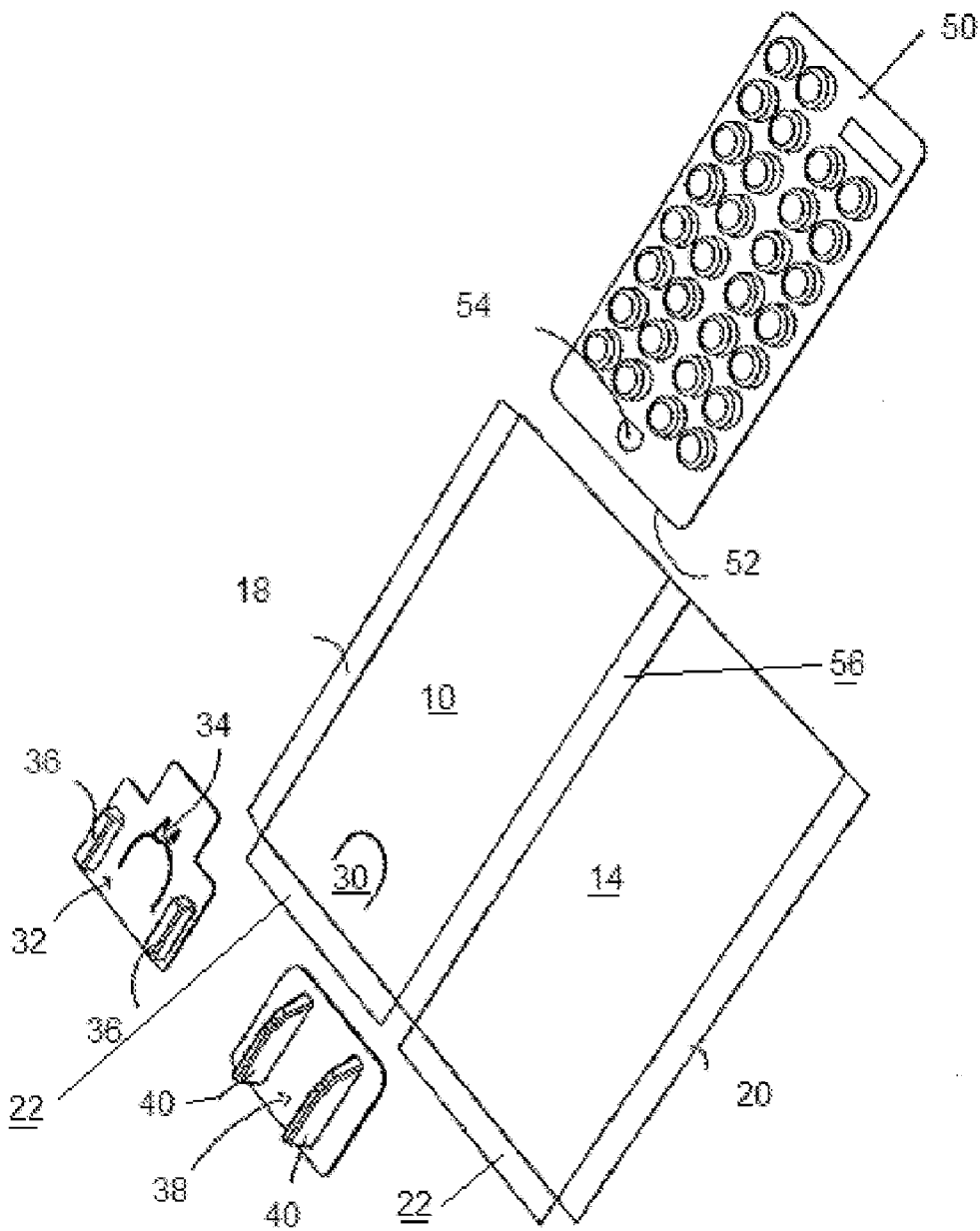

Figure 8

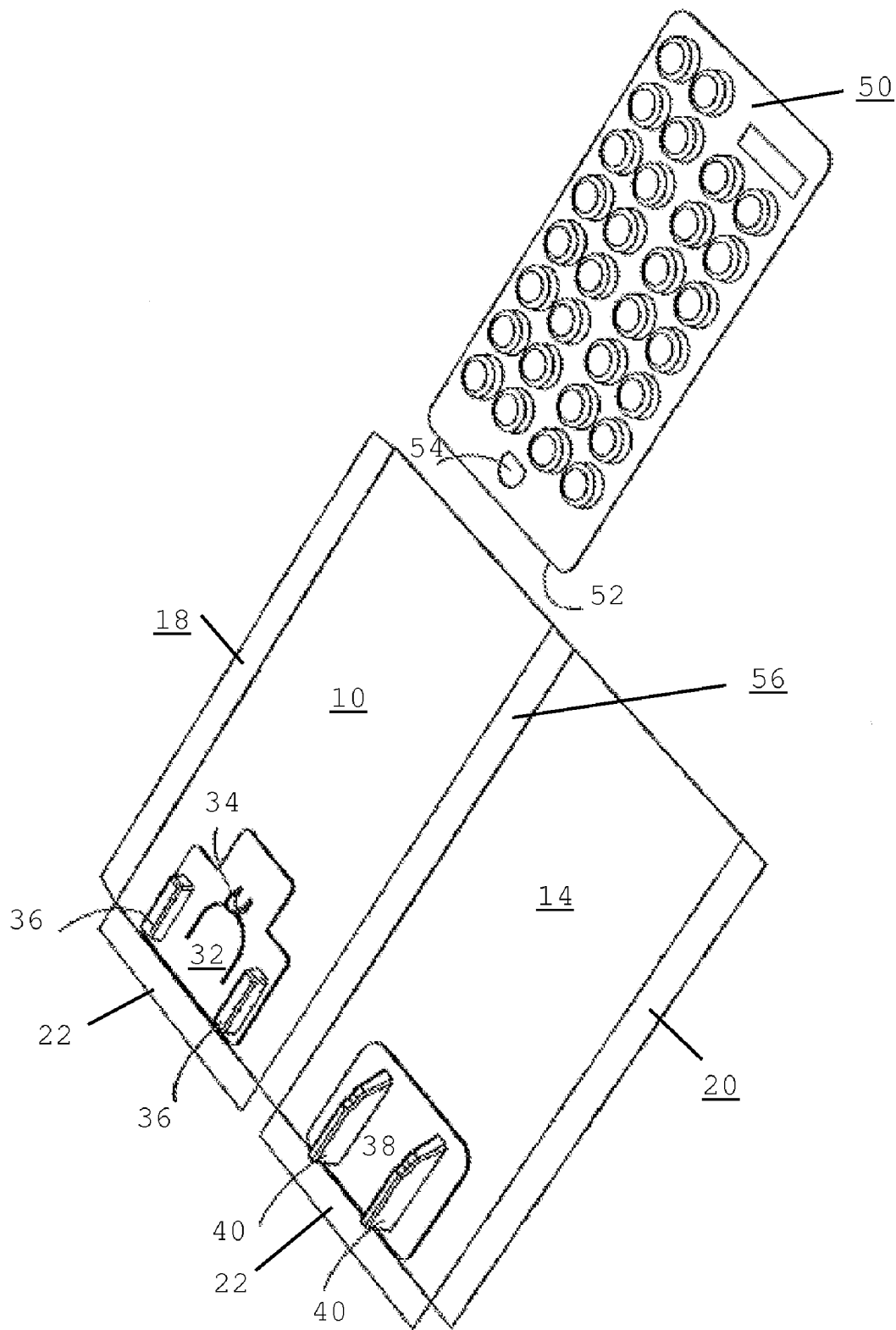

Figure 9

PAPER SHELLPAK CONTAINER

BACKGROUND OF THE INVENTION

[0001] Typical shell packaging containers for blister package inserts (or the like) are made almost entirely from hard molded plastic. An alternative form of container packaging uses paperboard materials rather than molded plastic. Each type of container further strives to achieve a level of child-resistance with respect to accessing the blister package(s) within the containers. There are locking and unlocking mechanisms and features built-in to both the plastic shell containers and the paperboard containers that are designed to retain the blister package(s) securely within its respective outer container. A user must know how to disengage the lock mechanism in order to gain access to the blister package(s). Typically, the plastic lock/unlock mechanisms are more durable and stronger than the paperboard lock/unlock mechanisms. What is needed is a modified packaging system comprised mainly of a paperboard casing that only uses a portion of hard molded plastic that comprise the lock/unlock mechanisms.

SUMMARY OF THE INVENTION

[0002] Disclosed is a paperboard container made from a paperboard material. Such material may be treated and/or may be tear-resistant. A top and bottom panel, each having side panels that extend the length of either side are folded over and separated by an end panel to form an open ended substantially rectangular box having an interior chamber. The side panels fold atop and may be attached to one another. A locking apparatus made from a molded plastic may be affixed to the top panel. The locking apparatus may include a pair of spaced apart stop pieces and an angled locking post that protrude away from the surface of the top panel. A guide apparatus made from a molded plastic may be affixed to the bottom panel. The guide apparatus may include a pair of spaced apart ramps. The locking apparatus and the guide apparatus are oriented within the chamber in such a manner as to cooperate to receive and retain at least one substantially flat insert (e.g., a blister package) having a cut out area adapted to fit over the angled locking post.

[0003] To add strength to the overall structure, the top and bottom panels can be reinforced with secondary top and bottom panels that fold over and are adhered to their respective primary top and bottom panels. The secondary top and bottom panels include cut out areas to allow the molded plastic locking apparatus and guide apparatus to protrude through. This style of fitting allows for the plastic pieces to be held in place without the use of adhesive if so desired. The benefit of not using adhesive materials to adhere the plastic pieces to the board is it allows for complete separation of the comingled materials which improves the recyclability of the package.

[0004] A push button cut out area may be oriented between the spaced apart stop pieces of the primary top panel provides a lock release mechanism. When a user depresses the push button cut out area on the top panel, the blister package insert will also be depressed such that its cut out area will become unhooked from the angled locking post.

[0005] A finger cut out area at the open end of the paperboard container may also be included to assist the user in grasping the inserted blister package for easier removal.

BRIEF DESCRIPTION OF THE DRAWINGS

[0006] FIG. 1 is an illustration of a paperboard container prior to assembly according to an embodiment of the invention.

[0007] FIG. 2 is an illustration of the paperboard container of FIG. 1 shown partially assembled.

[0008] FIGS. 3-5 are illustrations of the paperboard container of FIGS. 1-2 shown in partially assembled states with molded plastic components attached thereto.

[0009] FIG. 6 is an illustration of a blank blister package adapted to lockably fit within the paperboard container (once assembled).

[0010] FIG. 7 illustrates a view of an assembled paperboard container with a blister package contained therein.

[0011] FIG. 8 illustrates an open two panel paperboard container.

[0012] FIG. 9 shows an the paperboard container of FIG. 8 with the components attached thereto.

DETAILED DESCRIPTION OF THE PREFERRED EMBODIMENTS

[0013] FIG. 1 is an illustration of a paperboard container 1 prior to assembly according to an embodiment of the invention. The paperboard container is generally comprised of an outside top panel 10, an inside top panel 12, an outside bottom panel 14, an inside bottom panel 16 laid out end to end. Also shown are a pair of top side panels 18, a pair of bottom side panels 20, and an end panel 22 that are configured as shown. Also included are a variety of cut out areas including a lock and stop cut out area 26 positioned on the inside top panel 12, a circular finger cut out area 28 that is bisected by an edge separating the inside top panel 12 and the outside top panel 10, a push button cut out feature 30 positioned on the outside top panel 10, and a pair of ramp cut out areas 24 positioned on the inside bottom panel 16.

[0014] The paperboard material is generally comprised of layers of paperboard that may be treated. The paperboard could be strengthened by coatings or by production processes. The paperboard could be improved for printing capabilities by coatings or production process steps. The inner structure me be made of molded plastic, injection molded, blow molded, thermoformed, or other similar means. In the alternative, the inner structure could be made of pressed paperboard, pressed metal, or pulped formed paper depending upon manufacturing preferences.

[0015] FIG. 2 is an illustration of the paperboard container 1 of FIG. 1 shown partially assembled. In this illustration, the inside top panel 12 is shown partially folded pivoting about the edge it shares with the outside top panel 10. This is the same edge that bisects the circular finger cut out area 28. Similarly, the inside bottom panel 16 is shown partially folded pivoting about the edge it shares with the outside bottom panel 14.

[0016] FIGS. 3-5 are illustrations of the paperboard container 1 of FIGS. 1-2 shown in partially assembled states with molded plastic components attached thereto. There is shown a lock and stop apparatus 32 comprised of molded plastic that is vacuum packed and attached to the surface of the outside top panel 10. The lock and stop apparatus 32 is comprised of a pair of thermo-formed blister stops 36 and a thermo formed blister lock post 34. A more complete description of how the lock and stop apparatus functions relative to a blister package is set out below.

[0017] Also shown is a molded plastic guide apparatus 38 that is vacuum packed and adhered to the surface of the outside bottom panel 14. The plastic guide apparatus 38 is comprised of a pair of thermo-formed blister ramps 40. A

more complete description of how the guide apparatus functions relative to a blister package is set out below.

[0018] FIG. 4 illustrates the paperboard container 1 partially assembled wherein the inside top panel 12 has been folded completely over and on top of the outside top panel 10. Similarly, the inside bottom panel 16 has been folded completely over and on top of the outside bottom panel 14. The circular finger cut out area 28 now appears as a semi-circle at one end of the paperboard package 1. The lock and stop cut out area 26 is positioned to allow the lock and stop apparatus 32 and its sub-components (blister lock post 34 and blister stops 36) to show through the opening defined by the lock and stop cut out area 26. Similarly, the ramp cut out areas 24 are positioned to allow the guide apparatus 38 and its sub-components (blister ramps 40) to show through the opening defined by the ramp cut out areas 24. The top panel 12 and the bottom panel 16 may hold the plastic components (lock and stop apparatus etc) in place without the use of an adhesive. It is to be understood that manufacturing preferences will indicate what material is best suited for the additional components.

[0019] FIG. 5 illustrates the paperboard container 1 partially assembled wherein the top panels 10, 12 and the bottom panels 14, 16 are shown being folded toward one another. The top panels 10, 12 and the bottom panels 14, 16 are separated by end panel 22 which defines the height dimension of the assembled paperboard container 1. The left and right top side panels 18 and the left and right bottom side panels 20 will overlap one another respectively when the top panels 10, 12 and the bottom panels 14, 16 are fully folded. The side panels 18, 20 can then be adhered to one another in some fashion (e.g., gluing, adhesive tape, etc . . .) to form the assembled paperboard container 1.

[0020] In its assembled state, the blister ramps 40, the blister stops 36, the blister lock post 34 and the push button cut-out feature 30 become oriented such that a locking mechanism adapted to receive at least one blister package is formed.

[0021] FIG. 6 is an illustration of a blank blister package 50 adapted to lockably fit within the paperboard container (once assembled). The blister package 50 includes a leading edge 52 and a locking cut out area 54. Not shown in this illustration are the plurality of individually sealed unit containers that are typically associated with blister packaging.

[0022] In operation, a user would insert a blister package into the open end of a chamber defined by the assembled paperboard container 1. The leading edge 52 of the blister package 50 travels toward the far end of the paperboard container 1. Near the far end, the leading edge 52 will encounter blister ramps 40 that are angled and oriented such that the leading edge 52 will slide up and over the ramped surface. As the blister package 50 continues toward the far end of the paperboard container 1, it may next encounter the angled blister lock post 34. Angled blister lock post 34 may re-direct the leading edge back downward a bit until the locking cut out area 54 of the blister package 50 clears the blister lock post 34 and hooks over it. The locking cut out area 54 of the blister package 50 is aligned with the position of the blister lock post 34 when the blister package 50 is inserted into the paperboard container 1. Shortly after the locking cut out area 54 of the blister package 50 clears the blister lock post 34 and hooks over it the leading edge 52 will encounter the protruding blister stops 36. The blister package 50 is now fully inserted and locked within the paperboard container 1.

[0023] FIG. 7 illustrates a view of an assembled paperboard container 1 with a blister package 50 contained therein. To release the locking mechanism and remove the blister package from the paperboard container, the user grasps the exposed portion (defined by the finger cut out area 26) of blister package 50 in one hand while holding the other end of the paperboard container 1 in their other hand. The user then depresses (usually with the thumb) the push button cut out feature 30 on the outside top panel 10 of the paperboard container 1. As the push button cut out feature 30 moves downward it contacts the surface of the blister package 50 also moving it downward. Once the blister package 50 has moved sufficiently downward, the cut out area 54 of the blister package 50 will again clear and unhook from the blister lock post 34. Once this occurs the user can pull the blister package 50 out of the paperboard container 1 without it catching on the blister lock post 34.

[0024] FIGS. 8 and 9 illustrate a different way to make this paperboard container. The paperboard container may have two panels, a top panel 10 and a bottom panel 14. The two panels are connected together by at least one side panel 56. It is to be understood the package could be formed with the top panel 10 connected to the bottom panel by end panel 22 and there could be two side panel 18 off of top panel 10 and two side panel 20 off of bottom panel 14. In the current embodiment, at least one end panel 22 extends off one or more of the closed end sides of top panel 10 and bottom panel 14. Top panel 10 has a push button cut out feature 30 that aligns with stop apparatus 32 which has two or more sub-components (blister lock post 34 and blister stops 36). In this two panel design, stop apparatus 32 may be adhered to top panel 10. Guide apparatus 38 is aligned with stop apparatus 32 on bottom panel 14. It may be adhered to bottom panel 14. Stop apparatus 32 and guide apparatus 38 may be adhered to the panels with staples, tape, glue, pressure adhesive, heat seal adhesive, or any other adhesive like material. End flaps 22 may overlap and be sealed to form the closed end of the package. Side panels 18 and 20 may overlap and be sealed together to form a second side panel parallel to first side panel 56. Blister card 50 may be slid into the package the leading edge 52 to match up with the inside of panels 22 or the closed end of the package. The locking cut out area 54 may align with locking post 34 such that the card is held in place until the user presses on cut out 30 lowering the blister card until locking cut out area 54 is able to slide past locking post 34.

[0025] It is to be understood that a wide variety of materials may be used to make the internal components (guide rails, locking elements, retaining elements and/or other such elements), including but not limited to plastic, plastic biopolymers and/or other plastic based compositions. It is to be understood that the one or more retaining elements may be a catch, an opening, a lip, a ledge, a flap, a blister, a bump, a protrusion, an indentation or any elements or combinations thereof that would prevent the blister from being fully removed without undue force from the outer container or shell.

[0026] It is believed that the present invention includes many other embodiments that may not be herein described in detail, but would nonetheless be appreciated by those skilled in the art from the disclosures made. Accordingly, this disclosure should not be read as being limited only to the foregoing examples or only to the designated embodiments.

- 1. A paperboard container comprising:
 - a top panel made from a paperboard material, the top panel further comprising:
 - a pair of side panels made from a paperboard material that extend the length of the top panel on either side; and
 - a locking apparatus made from a material other than paperboard that is affixed thereon, the locking apparatus including a pair of spaced apart stop pieces and an angled locking post that protrude away from the surface of the top panel;
 - a bottom panel made from a paperboard material, the bottom panel further comprising:
 - a pair of side panels made from a paperboard material that extend the length of the bottom panel on either side; and
 - a guide apparatus made from a material other than paperboard that is affixed thereon, the guide apparatus including a pair of spaced apart ramps; and
 - an end panel made from a paperboard material, wherein the top side panels and the bottom side panels overlap one another and are adhered together with an adhesive thereby forming an open ended substantially rectangular box having an interior chamber in which the locking apparatus and the guide apparatus are oriented within the chamber in such a manner as to cooperate to receive and retain at least one substantially flat insert having a cut out area adapted to fit over the angled locking post.
- 2. The paperboard container of claim 1 wherein the top panel further comprises a push button cut out area oriented between the spaced apart stop pieces.
- 3. The paperboard container of claim 1 wherein the top panel further comprises a finger cut out area at the open end of the open ended substantially rectangular box.
- 4. The paperboard container of claim 1 wherein the substantially flat insert is a blister package having a cut out area.
- 5. The paperboard container of claim 1 wherein the locking apparatus is plastic.
- 6. The paperboard container of claim 1 wherein the guide apparatus is plastic.
- 7. A paperboard container comprising:
 - an outside top panel made from a paperboard material, the outside top panel further comprising:
 - a pair of side panels made from a paperboard material that extend the length of the top panel on either side; and
 - a locking apparatus made from a material other than paperboard, the locking apparatus including a pair of spaced apart stop pieces and an angled locking post that protrude away from the surface of the top panel;
 - an inside top panel made from a paperboard material, the inside top panel further comprising a locking apparatus cut out area;
 - an outside bottom panel made from a paperboard material, the outside bottom panel further comprising:

- a pair of side panels made from a paperboard material that extend the length of the bottom panel on either side; and
 - a guide apparatus made from a material other than paperboard, the guide apparatus including a pair of spaced apart ramps;
 - an inside bottom panel made from a paperboard material, the inside bottom panel further comprising a ramp cut out areas; and
 - an end panel made from a paperboard material, wherein,
 - the inside top panel folds over onto the outside top panel such that the locking apparatus protrudes through the locking apparatus cut out area;
 - the inside bottom panel folds over onto to the outside bottom panel such that the spaced apart ramps protrude through the ramp cut out areas; and
 - the top side panels and the bottom side panels overlap one another and are adhered together with an adhesive thereby forming an open ended substantially rectangular box having an interior chamber in which the locking apparatus and the guide apparatus are oriented within the chamber in such a manner as to cooperate to receive and retain at least one substantially flat insert having a cut out area adapted to fit over the angled locking post.
- 8. The paperboard container of claim 7 wherein the inside top panel is adhered to the outside top panel and the inside bottom panel is adhered to the outside bottom panel.
- 9. The paperboard container of claim 7 wherein the locking apparatus and the guide apparatus are adhered to the top panel and bottom panels respectively.
- 10. The paperboard container of claim 7 wherein the top panel further comprises a push button cut out area oriented between the spaced apart stop pieces.
- 11. The paperboard container of claim 7 wherein the outside and inside top panels further comprises a finger cut out area at the open end of the open ended substantially rectangular box.
- 12. The paperboard container of claim 7 wherein the substantially flat insert is a blister package having a cut out area.
- 13. The paperboard container of claim 1 wherein the locking apparatus is plastic.
- 14. The paperboard container of claim 1 wherein the guide apparatus is plastic.
- 15. A paperboard container comprising of a closed end and an open end and further having one or more internal components that are formed of a different material than the paperboard container.
- 16. The paperboard container of claim 15 wherein the one or more internal component is a locking mechanism.
- 17. The paperboard container of claim 15 wherein the one or more internal component is a retaining mechanism.
- 18. The paperboard container of claim 15 wherein the one or more internal component is made of plastic.
- 19. The paperboard container of claim 15 wherein the plastic is a biopolymer.

* * * * *