

(19)



Europäisches Patentamt
European Patent Office
Office européen des brevets



(11)

EP 0 829 368 A2

(12)

EUROPEAN PATENT APPLICATION

(43) Date of publication:
18.03.1998 Bulletin 1998/12

(51) Int Cl.⁶: **B41J 2/21, D06P 5/00**

(21) Application number: **97306940.4**

(22) Date of filing: **08.09.1997**

(84) Designated Contracting States:
**AT BE CH DE DK ES FI FR GB GR IE IT LI LU MC
NL PT SE**

(72) Inventor: **Rayfield, Wilson P.**
Dayton, Ohio 45459 (US)

(30) Priority: **11.09.1996 US 710103**

(74) Representative: **Freed, Arthur Woolf et al**
Reginald W. Barker & Co.,
Chancery House,
53-64, Chancery Lane
London, WC2A 1QU (GB)

(71) Applicant: **Scitex Digital Printing, Inc.**
Dayton, Ohio 45420-4099 (US)

(54) Biased serial ink jet printing system for textiles

(57) A method is provided for using an ink jet printer to print on a textile substrate. One or more printheads are oriented to scan the width of the textile web at a bias angle. A different printhead can be used for each color ink, whereby the ink is projected across an air gap to the

textile web during the scan. Arranging the multiple print-heads for parallel scanning allows each printhead to scan a separate swath simultaneously. Additional scan widths can be left between printheads to allow for sufficient ink absorption or drying time prior to applying the next color.

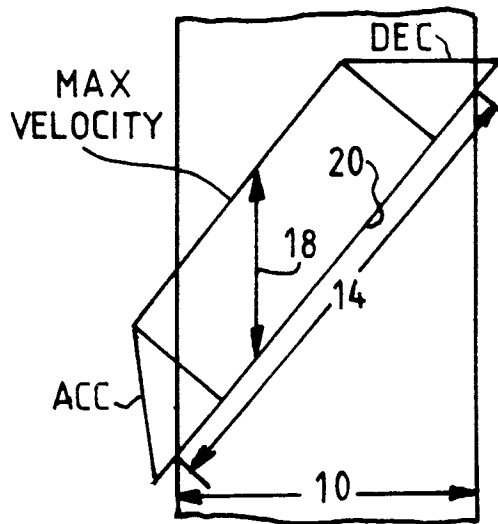

FIG. 3

EP 0 829 368 A2

Description

Technical Field

The present invention relates to continuous ink jet printing technology and, more particularly, to applying ink jet printing technology to textile printing.

Background Art

Continuous binary array ink jet technology was first successfully commercialized by Mead Corporation of Dayton, Ohio, in the mid-nineteen-seventies. In this technology, a print head defines one or more rows of orifices which receive an electrically conductive recording fluid, such as for instance a water base ink, from a pressurized fluid supply manifold and ejects the fluid in rows of parallel streams. Printers using such print heads accomplish graphic reproduction by selectively charging and deflecting the drops in each of the streams and depositing at least some of the drops on a print receiving medium, while others of the drops strike a drop catcher device.

Textiles are traditionally printed by gravure, rotary screens, or flat screen technologies and are printed in continuous web form to enable in-line steaming, washing or other processes. Color patterns are generally limited to multicolor applications using custom mixed ink colors at each of a number of print stations along the web. Changing colors requires changing the inks and cleaning the screens or cylinders of each print station. Changing designs requires changing of the screens or gravure cylinders. Setup time is extensive and costly. This in turn drives the industry to long print runs and costly inventorying of large quantities of printed fabric. Ink jet can generally print with dye or pigment based inks similar to those currently used by textile printers. Unlike electrostatic printing technologies such as electrophotography (laser), ion deposition, or magnetography there is generally no downstream fusing or fixing step required. The two most commonly used ink jet technologies are drop-on-demand (DOD) and continuous ink jet (CIJ). DOD ink jet printing heads form drops only when needed to print. This intermittent drop formation is generally limited to maximum drop frequencies of 10,000 to 20,000 hertz. DOD printheads have been developed primarily for use in serial printers where the printhead scans along the length of a roller supporting the paper. Thus the array size of many DOD printheads is relatively small (less than 2 cm.). These two factors (low frequency of drop formation and small array size) limit the area of substrate (paper or textile) that can be printed within a set time. Since fabric printing involves a much wider width than paper, often two meters or more, DOD technology has been limited to low speed proofing and sample printing rather than applied to production printing of textiles. The achievement of production speeds (greater than 1,000 square meters per hour)

would require an impractically large number of DOD printheads.

Continuous ink jet printing, on the other hand, is geared more toward production speeds in industrial applications. This technology continually produces drops enabling drop rates of 100,000 hertz or more. Drops not needed for printing are charged, deflected, captured and recirculated. CIJ, as practiced, for example, by Sci-tex Digital Printing, Inc., of Dayton, Ohio, utilizes array lengths of 10-25 cm. However, the current state of CIJ technology does not enable a single fixed printhead to cover the entire width of a textile web. While multiple fixed printheads could do so, this number would need to be repeated for each of the three or more process colors. Although this would result in a very high speed system (100-200 meters per minute), it would, like DOD, require an impractically large number of printheads.

It is seen then that there is a need for a configuration that requires movement of both the printheads and the textile to permit full array coverage with a reasonable number of printheads.

Summary of the Invention

This need is met by the biased serial ink jet printing system according to the present invention. Ink jet is particularly well suited to textile printing in that it is a non-contact technology. The ink is projected across a small air gap to the fabric which accommodates a wide variety of fabric textures. Ink jet can generally print with dye or pigment based inks similar to those currently used by textile printers. Unlike electrostatic printing technologies such as electrophotography (laser), ion deposition, or magnetography, there is generally no downstream fusing or fixing step required.

In accordance with one aspect of the present invention, a method is provided for using an ink jet printer to print on a textile substrate. The one or more printheads are oriented to scan the width of the textile web at a bias angle. A different printhead can be used for each color ink, whereby the ink is projected across an air gap to the textile web during the scan. Arranging the multiple printheads for parallel scanning allows each printhead to scan a separate swath simultaneously. Additional scan widths can be left between printheads to allow for sufficient drying time.

Accordingly, it is an object of the present invention to provide a continuous ink jet system for printing on textiles. It is a further object of the present invention to combine movement of printheads and the textile to achieve full array coverage with a reasonable number of printheads. It is an advantage of the present invention that the biased serial ink jet printing system according to the present invention maximizes textile printing efficiency. It is a further advantage of the present invention that reciprocating printhead movement across the web width is utilized.

Other objects and advantages of the invention will

be apparent from the following description, the accompanying drawings and the appended claims.

Brief Description of the Drawings

Fig. 1 illustrates bi-directional scanning of a printhead with intermittent web motion;
 Figs. 2a and 2b illustrate the period of the scan that operates at maximum velocity;
 Fig. 3 illustrates another longer scan distance printing configuration embodiment in accordance with the present invention, achieved by angling the scan direction across the width of the web;
 Fig. 4 is a vacuum bed configured to hold the web flat under biased scanning printheads;
 Fig. 5 illustrates a printhead array parallel to the web edge;
 Fig. 6 illustrates an angled printhead array embodiment of the present invention which enables a wider swath measured parallel to the web edge;
 Fig. 7 illustrates serially mounted process color printheads; and
 Fig. 8 illustrates an embodiment of the present invention wherein the printheads are mounted in a parallel configuration.

Detailed Description of the Preferred Embodiments

The present invention relates to the development of a configuration that combines movement of both the printheads and the textile to achieve full array coverage with a reasonable number of printheads. The present invention maximizes printing efficiency by providing for a longer sweep and, therefore, a greater percentage of maximum velocity print time. Efficiency of a configuration can be defined as the throughput actually achieved versus the throughput calculated assuming all printing is continuous at maximum speed.

Referring now to the drawings, one obvious approach to maximizing textile printing efficiency is to utilize the reciprocating printhead movement across a web width 10, much like a desktop serial printer. As illustrated in Fig. 1, printhead(s) 12 print on both the forward scan and return directions, with the scan direction and distance indicated by arrows 14a, 14b, 14c, 14d. The web advances, in the direction indicated by arrows 16, the width of one printing swath 18, as the printhead 12 pauses at the end of each scan 14. The printhead 12 will need to have completed printing on a given pass prior to advancing the substrate, or fabric 20, and the fabric will need to stop its movement prior to the start of the next pass of the printhead 12. One method for improving efficiency of this approach is to accelerate and decelerate the printhead during printing by utilizing a true position encoder to control timing of the print drops. Due to the high drop frequency of continuous ink jet printing, it is necessary to move the printhead with relatively high speed to take full advantage of the printing capability.

The large mass of a typical continuous ink jet printhead makes the ramp-up acceleration and ramp-down deceleration of the printhead significant factors in determining the configuration efficiency. That is, the longer the scan distance 14, the greater the percent of the scan that can be printed at maximum printhead speed and thus the higher the efficiency of the system. Figs. 2a and 2b illustrate how a longer scan distance results in a higher percent of scan period at maximum velocity. With the scan direction perpendicular to the web edge, as shown in Fig. 2a, the only way to improve efficiency due to the acceleration and deceleration ramps needed is to widen the web, as shown in Fig. 2b.

To further maximize efficiency, the present invention proposes that the printhead scan the width of the textile web at a bias angle to the standard cross web perpendicular, as illustrated in Fig. 3. The angled configuration illustrated in Fig. 3 enables a longer scan at full velocity with the same width web. In Fig. 3, a longer scan distance 14 is achieved, as compared to the scan of Fig. 1, without increasing the web width 10. With the textile configuration shown in Fig. 3, the ramp-up acceleration and the ramp-down deceleration of printhead 12 has less negative impact on overall printing efficiency.

Due to the length of the array and the close proximity required of the print array to the fabric, it is not practical to wrap the web over a roller as is done in the analogous serial printer. Fabric 20 must be held flat over the area being printed. It is also necessary to stabilize the fabric over this area. In applications using flat screen printing of multiple colors, this is accomplished by means of adhesive bonding the textile to a moving belt which, in turn, lies on a flat bed. After the fabric advances beyond the print station, it is stripped off the belt. Fig. 4 illustrates a vacuum bed 22 configured to hold the web and belt flat under biased scanning printheads. In accordance with the present invention, it is possible to utilize the vacuum array on the flat bed to hold the belt and, thus, the fabric 20, flat during the printing scan. This flat bed 22 is preferably shaped in the plan view to match the biased orientation of the print scan. For example, the flat bed 22 is shaped as a parallelogram in Fig. 4, to match the biased orientation of the print scan of Fig. 3. A second encoder (not shown) can be used to control the precise movement of the fabric and belt between scans to assure registration of swath edges, as well as registration of the various color ink scans.

If the printhead 12 were oriented such that the array were parallel to belt 24 and fabric 20 motion, the printhead swath 18 would equal the array length along the web direction, as illustrated in Fig. 5. This increases the printed resolution perpendicularly across the swath by a factor of $1/\cos \theta$, where θ is the bias angle of the swath to the cross web perpendicular. If the jet resolution of the array were sufficient, the printhead 12 could be angled such that the array is perpendicular to the biased scan direction, indicated by arrow 26, and an even wider swath 18 would be created during the scan, as is

illustrated in Fig. 6. Thus, in the preferred orientation of Fig. 6, increasing the bias angle of the scan lengthens the scan, widens the swath as measured along the web direction, and increases the configuration efficiency. However, the disadvantage of increasing the bias angle is that it requires an even larger flat bed 22 to maintain good quality printing. Also, as the bias angle increases, an enlarging portion of printhead travel occurs where a portion of the jet array is not used at the edges of the fabric, subtracting some of the efficiency gained from the biased configuration. Hence, a practical compromise might be a printhead angle in the range of 30 to 60 degrees.

To print process color images it is desirable to use at least three printheads with process color inks, which are cyan (c), magenta (m) and yellow (y). A fourth printhead with black ink (k) can also be included to improve image contrast. Additional printheads with other colors may be added to broaden the color space achievable. Multiple printheads can be aligned on a single carriage to scan across the web serially. Serially mounting of the printheads would minimize the width of the flat bed controlling the belt and fabric, as illustrated in Fig. 7. However, the total scan length 28 would increase by "a", as shown in Fig. 7, to enable each of the three or more printheads 12 to cover the full width of the textile. Also, this configuration would provide insufficient time for each ink to absorb into the textile or dry prior to the next color ink striking the surface. This could cause spatter of inks and reduce image quality. This arrangement would also introduce color shift by laying down the process colors in a different sequence on alternate direction scans.

Parallel scanning, in accordance with the present invention, allows each printhead 12 to scan a separate swath simultaneously, as illustrated in Fig. 8. The next color would be added at the subsequent printhead after the fabric and belt are advanced, providing time for the ink to penetrate or dry. Parallel scanning also enables printing the process colors in the same sequence with each scan.

As can be seen in Fig. 8, the angling of the printheads 12 accommodates the parallel configuration by allowing the printheads to overlap, thereby minimizing the size of the flat bed 22. If necessary, the printheads could be spaced to require one or more unprinted scan widths between adjacent printheads, to allow drying time before the next color overlaps. Of course, this approach requires a wider flat bed.

The biased scan approach creates a rectilinear matrix at the angle θ to the fabric. Although this might pose problems for printing text on paper, it is not a significant factor for printing patterns and designs on fabric. The angled matrix minimizes interference patterns caused by slight misalignment of the printing matrix with the weave of the fabric, which could occur more easily if the printhead scanned perpendicular to the web along the weave pattern.

Although the preferred mode of practicing the in-

vention has been described with reference to an ink jet print head for a continuous ink jet printer printing on textile, the principle of the present invention can also be applied to a - wide variety of ink jet printers and substrates.

Industrial Applicability and Advantages

The biased serial ink jet printing system according to the present invention is useful for printing colors and patterns on textiles, because ink jet technology offers a way to print digitally on textiles. Multiple printheads printing a range of process colors can produce a color gamut enabling thousands of colors and shades within a single image. This digital printing technology can instantly change colors and patterns with no change of ink or screens. Thus, the economics of printing a range of colors and patterns are not affected by the length of the run. The textile printer can print only the yardage needed to fill current orders without concern for carrying large backup inventories. Repeat orders can be printed "on demand" with little concern for the size of the order. This capability can provide textile consumers with a larger variety of colors and patterns in a timely and cost effective manner. This in turn can provide a larger number of "design collections" per year. Sending digital images directly to the printing system without making screens or mixing ink, digital printing of textiles can provide quicker responses to customers' demands.

Having described the invention in detail and by reference to the preferred embodiment thereof, it will be apparent that other modifications and variations are possible without departing from the scope of the invention defined in the appended claims.

Claims

1. A method for printing on textile comprising the steps of:
 - providing at least one printhead for releasing ink;
 - providing a textile web, the textile web having a width;
 - orienting the at least one printhead to scan the width of the textile web at a bias angle, defining a scan width;
 - projecting ink from the at least one printhead across an air gap to the textile web during the scan.
2. A method for printing on textile as claimed in claim 1 wherein the step of providing at least one printhead further comprises the step of providing a plurality of printheads for releasing a plurality of color inks.

3. A method for printing on textile as claimed in claim 2 wherein each one of the plurality of color inks is released from a different one of the plurality of print-heads. 5
4. A method for printing on textile as claimed in claim 2 further comprising the step of providing at least one unprinted scan width between adjacent pairs of the plurality of printheads. 10
5. A method for printing on textile as claimed in claim 3 wherein the plurality of printheads are aligned in a parallel scanning configuration.
6. A method for printing on textile as claimed in claim 5 wherein each of the plurality of printheads scans a separate swath simultaneously. 15
7. A method for printing on textile as claimed in claim 6 wherein each of the plurality of color inks is applied to the substrate in the same sequence independent of scanning direction. 20
8. A method for printing on textile as claimed in claim 1 wherein the bias angle of the at least one print-head comprises an angle in the range of 30 to 60 degrees. 25

30

35

40

45

50

55

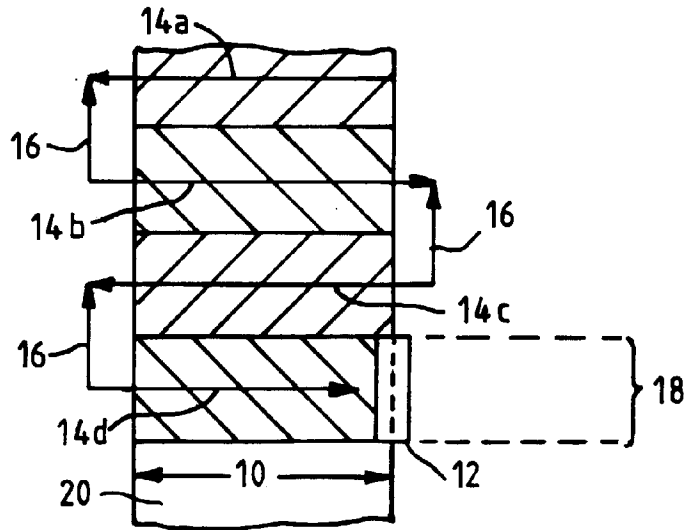

FIG. 1

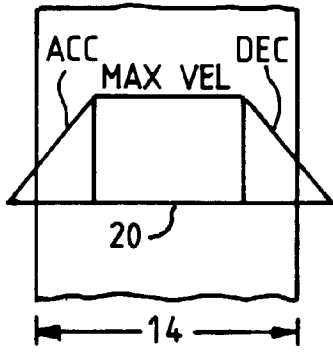

FIG. 2a

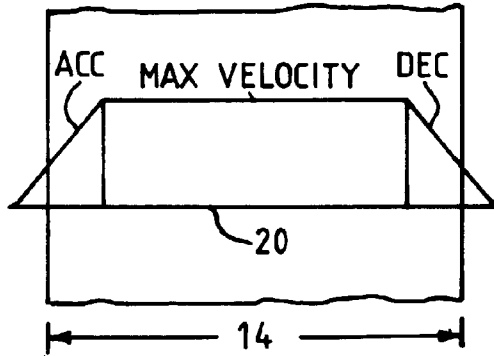

FIG. 2b

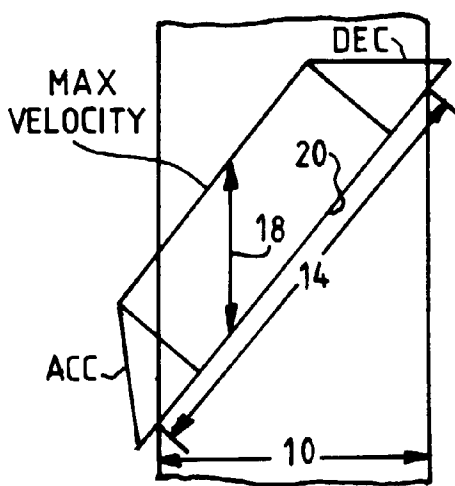

FIG. 3

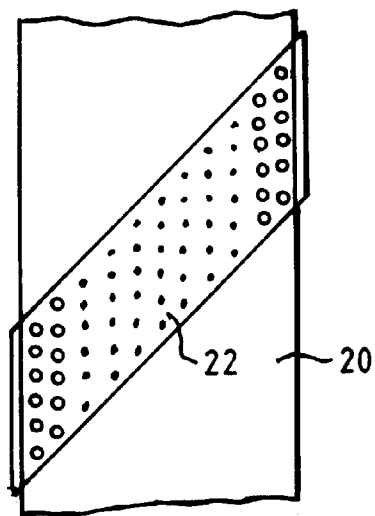

FIG. 4

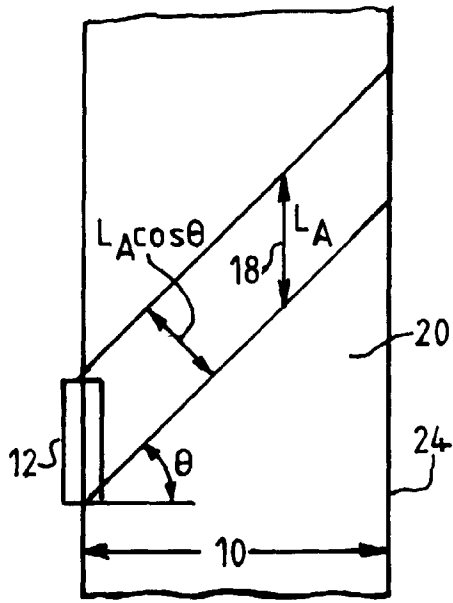

FIG. 5

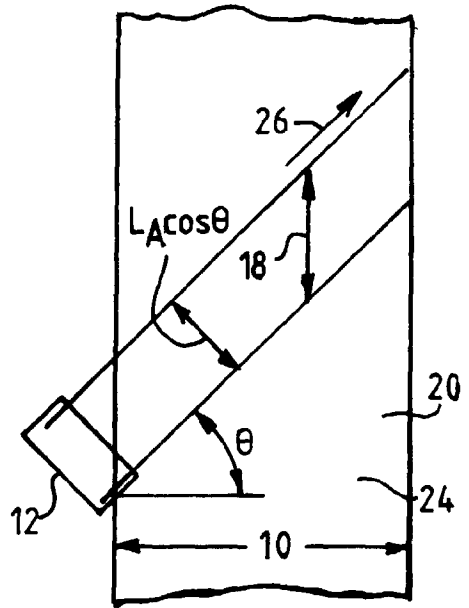

FIG. 6

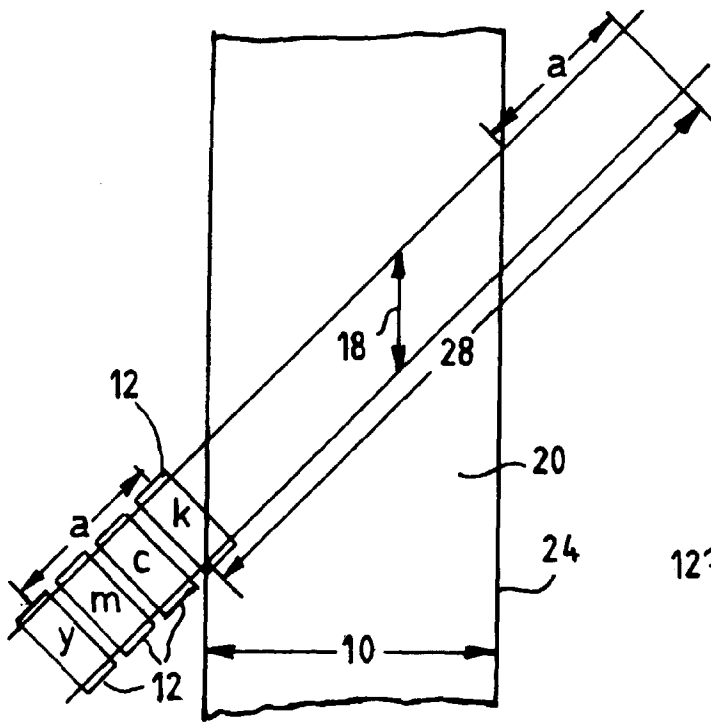

FIG. 7

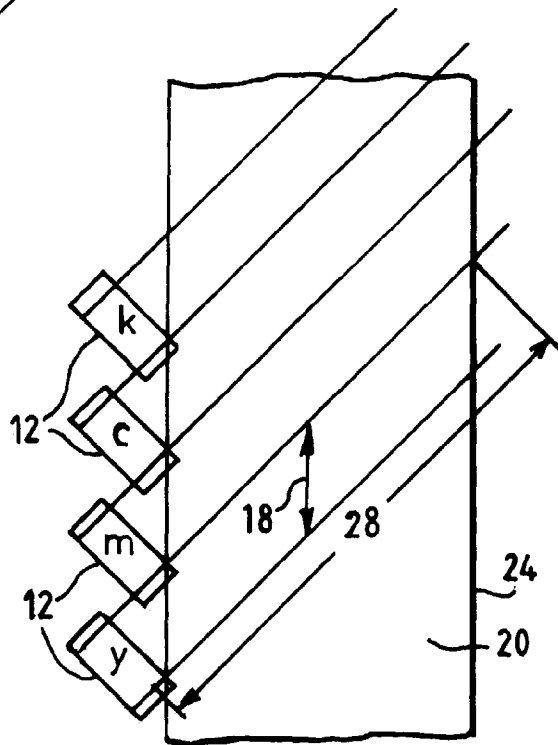

FIG. 8