



## INTERNATIONAL APPLICATION PUBLISHED UNDER THE PATENT COOPERATION TREATY (PCT)

<b>(51) International Patent Classification <sup>6</sup> :</b>  <b>G06K</b>	<b>A2</b>	<b>(11) International Publication Number:</b> <b>WO 99/31617</b>  <b>(43) International Publication Date:</b> 24 June 1999 (24.06.99)
<b>(21) International Application Number:</b> PCT/US98/25587 <b>(22) International Filing Date:</b> 3 December 1998 (03.12.98)  <b>(30) Priority Data:</b> 08/992,763                      17 December 1997 (17.12.97)      US  <b>(71) Applicant:</b> SRC COMPUTERS, INC. [US/US]; 4240 North Nevada Avenue, Colorado Springs, CO 80907 (US). <b>(72) Inventors:</b> HUPPENTHAL, Jon, M.; 10015 Burgess Road, Colorado Springs, CO 80908 (US). LESKAR, Paul, A.; 755 Nebula Court, Colorado Springs, CO 80906 (US). <b>(74) Agents:</b> BURTON, Carol, W. et al.; Holland & Hart L.L.P., Suite 3200, 555 17th Street, P.O. Box 8749, Denver, CO 80201-8749 (US).		<b>(81) Designated States:</b> CA, JP, MX, European patent (AT, BE, CH, CY, DE, DK, ES, FI, FR, GB, GR, IE, IT, LU, MC, NL, PT, SE).  <b>Published</b> <i>Without international search report and to be republished upon receipt of that report.</i>
<b>(54) Title:</b> MULTIPROCESSOR COMPUTER ARCHITECTURE INCORPORATING A PLURALITY OF MEMORY ALGORITHM PROCESSORS IN THE MEMORY SUBSYSTEM		
<b>(57) Abstract</b>  <p>A multiprocessor computer architecture incorporating a plurality of programmable hardware memory algorithm processors ("MAP") in the memory subsystem. The MAP may comprise one or more field programmable gate arrays ("FPGAs") which function to perform identified algorithms in conjunction with, and tightly coupled to, a microprocessor and each MAP is globally accessible by all of the system processors for the purpose of executing user definable algorithms. A circuit within the MAP signals when the last operand has completed its flow thereby allowing a given process to be interrupted and thereafter restarted. Through the use of read only memory ("ROM") located adjacent the FPGA, a user program may use a single command to select one of several possible pre-loaded algorithms thereby decreasing system reconfiguration time. A computer system memory structure MAP disclosed herein may function in normal or direct memory access ("DMA") modes of operation and, in the latter mode, one device may feed results directly to another thereby allowing pipelining or parallelizing execution of a user defined algorithm. The system of the present invention also provides a user programmable performance monitoring capability and utilizes parallelizer software to automatically detect parallel regions of user applications containing algorithms that can be executed in the programmable hardware.</p>		

**FOR THE PURPOSES OF INFORMATION ONLY**

Codes used to identify States party to the PCT on the front pages of pamphlets publishing international applications under the PCT.

AL	Albania	ES	Spain	LS	Lesotho	SI	Slovenia
AM	Armenia	FI	Finland	LT	Lithuania	SK	Slovakia
AT	Austria	FR	France	LU	Luxembourg	SN	Senegal
AU	Australia	GA	Gabon	LV	Latvia	SZ	Swaziland
AZ	Azerbaijan	GB	United Kingdom	MC	Monaco	TD	Chad
BA	Bosnia and Herzegovina	GE	Georgia	MD	Republic of Moldova	TG	Togo
BB	Barbados	GH	Ghana	MG	Madagascar	TJ	Tajikistan
BE	Belgium	GN	Guinea	MK	The former Yugoslav Republic of Macedonia	TM	Turkmenistan
BF	Burkina Faso	GR	Greece	ML	Mali	TR	Turkey
BG	Bulgaria	HU	Hungary	MN	Mongolia	TT	Trinidad and Tobago
BJ	Benin	IE	Ireland	MR	Mauritania	UA	Ukraine
BR	Brazil	IL	Israel	MW	Malawi	UG	Uganda
BY	Belarus	IS	Iceland	MX	Mexico	US	United States of America
CA	Canada	IT	Italy	NE	Niger	UZ	Uzbekistan
CF	Central African Republic	JP	Japan	NL	Netherlands	VN	Viet Nam
CG	Congo	KE	Kenya	NO	Norway	YU	Yugoslavia
CH	Switzerland	KG	Kyrgyzstan	NZ	New Zealand	ZW	Zimbabwe
CI	Côte d'Ivoire	KP	Democratic People's Republic of Korea	PL	Poland		
CN	Cameroon	KR	Republic of Korea	PT	Portugal		
CU	Cuba	KZ	Kazakstan	RO	Romania		
CZ	Czech Republic	LC	Saint Lucia	RU	Russian Federation		
DE	Germany	LI	Liechtenstein	SD	Sudan		
DK	Denmark	LK	Sri Lanka	SE	Sweden		
EE	Estonia	LR	Liberia	SG	Singapore		

**MULTIPROCESSOR COMPUTER ARCHITECTURE  
INCORPORATING A PLURALITY OF MEMORY  
ALGORITHM PROCESSORS IN THE MEMORY SUBSYSTEM**

**BACKGROUND OF THE INVENTION**

5           The present invention relates, in general, to the field of computer architectures incorporating multiple processing elements. More particularly, the present invention relates to a multiprocessor computer architecture incorporating a number of memory algorithm processors in the memory subsystem to significantly enhance overall system  
10   processing speed.

          All general purpose computers are based on circuits that have some form of processing element. These may take the form of microprocessor chips or could be a collection of smaller chips coupled together to form a processor. In any case, these processors are  
15   designed to execute programs that are defined by a set of program steps. The fact that these steps, or commands, can be rearranged to create different end results using the same computer hardware is key to the computer's flexibility. Unfortunately, this flexibility dictates that the hardware then be designed to handle a variety of possible  
20   functions, which results in generally slower operation than would be the case were it able to be designed to handle only one particular function. On the other hand, a single function computer is inherently not a particularly versatile computer.

          Recently, several groups have begun to experiment with creating  
25   a processor out of circuits that are electrically reconfigurable. This would allow the processor to execute a small set of functions more quickly and then be electrically reconfigured to execute a different small set. While this accelerates some program execution speeds, there are many functions that cannot be implemented well in this type  
30   of system due to the circuit densities that can be achieved in reconfigurable integrated circuits, such as 64-bit floating point math.

In addition, all of these systems are presently intended to contain processors that operate alone. In high performance systems, this is not the case. Hundreds or even tens of thousands of processors are often used to solve a single problem in a timely manner. This

5 introduces numerous issues that such reconfigurable computers cannot handle, such as sharing of a single copy of the operating system. In addition, a large system constructed from this type of custom hardware would naturally be very expensive to produce.

10

### **SUMMARY OF THE INVENTION**

In response to these shortcomings, SRC Computers, Inc., Colorado Springs, CO, assignee of the present invention, has developed a Memory Algorithm Processor ("MAP") multiprocessor computer architecture that utilizes very high performance

15 microprocessors in conjunction with user reconfigurable hardware elements. These reconfigurable elements, referred to as MAPs, are globally accessible by all processors in the systems. In addition, the manufacturing cost and design time of a particular multiprocessor computer system is relatively low inasmuch as it can be built using

20 industry standard, commodity integrated circuits and, in a preferred embodiment, each MAP may comprise a Field Programmable Gate Array ("FPGA") operating as a reconfigurable functional unit.

Particularly disclosed herein is the utilization of one or more FPGAs to perform user defined algorithms in conjunction with, and

25 tightly coupled to, a microprocessor. More particularly, in a multiprocessor computer system, the FPGAs are globally accessible by all of the system processors for the purpose of executing user definable algorithms.

In a particular implementation of the present invention disclosed

30 herein, a circuit is provided either within, or in conjunction with, the FPGAs which signals, by means of a control bit, when the last operand

has completed its flow through the MAP, thereby allowing a given process to be interrupted and thereafter restarted. In a still more specific implementation, one or more read only memory ("ROM") integrated circuit chips may be coupled adjacent the FPGA to allow a user program to use a single command to select one of several possible algorithms pre-loaded in the ROM thereby decreasing system reconfiguration time.

Still further provided is a computer system memory structure which includes one or more FPGAs for the purpose of using normal memory access protocol to access it as well as being capable of direct memory access ("DMA") operation. In a multiprocessor computer system, FPGAs configured with DMA capability enable one device to feed results directly to another thereby allowing pipelining or parallelizing execution of a user defined algorithm located in the reconfigurable hardware. The system and method of the present invention also provide a user programmable performance monitoring capability and utilizes parallelizer software to automatically detect parallel regions of user applications containing algorithms that can be executed in programmable hardware.

Broadly, what is disclosed herein is a computer including at least one data processor for operating on user data in accordance with program instructions. The computer includes at least one memory array presenting a data and address bus and comprises a memory algorithm processor associated with the memory array and coupled to the data and address buses. The memory algorithm processor is configurable to perform at least one identified algorithm on an operand received from a write operation to the memory array.

Also disclosed herein is a multiprocessor computer including a first plurality of data processors for operating on user data in accordance with program instructions and a second plurality of memory arrays, each presenting a data and address bus. The computer

comprises a memory algorithm processor associated with at least one of the second plurality of memory arrays and coupled to the data and address bus thereof. The memory algorithm processor is configurable to perform at least one identified algorithm on an operand received  
5 from a write operation to the associated one of the second plurality of memory arrays.

### **BRIEF DESCRIPTION OF THE DRAWINGS**

The aforementioned and other features and objects of the  
10 present invention and the manner of attaining them will become more apparent and the invention itself will be best understood by reference to the following description of a preferred embodiment taken in conjunction with the accompanying drawings, wherein:

Fig. 1 is a simplified, high level, functional block diagram of a  
15 standard multiprocessor computer architecture;

Fig. 2 is a simplified logical block diagram of a possible  
computer application program decomposition sequence for use in  
conjunction with a multiprocessor computer architecture utilizing a  
number of memory algorithm processors ("MAPs") in accordance with  
20 the present invention;

Fig. 3 is a more detailed functional block diagram of an  
individual one of the MAPs of the preceding figure and illustrating the  
bank control logic, memory array and MAP assembly thereof; and

Fig. 4 is a more detailed functional block diagram of the control  
25 block of the MAP assembly of the preceding illustration illustrating its  
interconnection to the user FPGA thereof.

### **DESCRIPTION OF A PREFERRED EMBODIMENT**

With reference now to Fig. 1, a conventional multiprocessor  
30 computer architecture is shown. The multiprocessor computer  
incorporates N processors  $12_0$  through  $12_N$  which are bi-directionally

coupled to a memory interconnect fabric 14. The memory interconnect fabric 14 is then also coupled to M memory banks comprising memory bank subsystems  $16_0$  (Bank 0) through  $16_M$  (Bank M).

With reference now to Fig. 2, a representative application program decomposition for a multiprocessor computer architecture 100 incorporating a plurality of memory algorithm processors in accordance with the present invention is shown. The computer architecture 100 is operative in response to user instructions and data which, in a coarse grained portion of the decomposition, are selectively directed to one of (for purposes of example only) four parallel regions  $102_1$  through  $102_4$  inclusive. The instructions and data output from each of the parallel regions  $102_1$  through  $102_4$  are respectively input to parallel regions segregated into data areas  $104_1$  through  $104_4$  and instruction areas  $106_1$  through  $106_4$ . Data maintained in the data areas  $104_1$  through  $104_4$  and instructions maintained in the instruction areas  $106_1$  through  $106_4$  are then supplied to, for example, corresponding pairs of processors  $108_1, 108_2$  (P1 and P2);  $108_3, 108_4$  (P3 and P4);  $108_5, 108_6$  (P5 and P6); and  $108_7, 108_8$  (P7 and P8) as shown. At this point, the medium grained decomposition of the instructions and data has been accomplished.

A fine grained decomposition, or parallelism, is effectuated by a further algorithmic decomposition wherein the output of each of the processors  $108_1$  through  $108_8$  is broken up, for example, into a number of fundamental algorithms  $110_{1A}, 110_{1B}, 110_{2A}, 110_{2B}$  through  $110_{8B}$  as shown. Each of the algorithms is then supplied to a corresponding one of the MAPs  $112_{1A}, 112_{1B}, 112_{2A}, 112_{2B}$  through  $112_{8B}$  in the memory space of the computer architecture 100 for execution therein as will be more fully described hereinafter.

With reference additionally now to Fig. 3, a preferred implementation of a memory bank 120 in a MAP system computer architecture 100 of the present invention is shown for a representative

one of the MAPs 112 illustrated in the preceding figure. Each memory bank 120 includes a bank control logic block 122 bi-directionally coupled to the computer system trunk lines, for example, a 72 line bus 124. The bank control logic block 122 is coupled to a bi-directional data bus 126 (for example 256 lines) and supplies addresses on an address bus 128 (for example 17 lines) for accessing data at specified locations within a memory array 130.

The data bus 126 and address bus 128 are also coupled to a MAP assembly 112. The MAP assembly 112 comprises a control block 132 coupled to the address bus 128. The control block 132 is also bi-directionally coupled to a user field programmable gate array ("FPGA") 134 by means of a number of signal lines 136. The user FPGA 134 is coupled directly to the data bus 126. In a particular embodiment, the FPGA 134 may be provided as a Lucent Technologies OR3T80 device.

The computer architecture 100 comprises a multiprocessor system employing uniform memory access across common shared memory with one or more MAPs 112 located in the memory subsystem, or memory space. As previously described, each MAP 112 contains at least one relatively large FPGA 134 that is used as a reconfigurable functional unit. In addition, a control block 132 and a preprogrammed or dynamically programmable configuration read-only memory ("ROM" as will be more fully described hereinafter) contains the information needed by the reconfigurable MAP assembly 112 to enable it to perform a specific algorithm. It is also possible for the user to directly download a new configuration into the FPGA 134 under program control, although in some instances this may consume a number of memory accesses and might result in an overall decrease in system performance if the algorithm was short-lived.

FPGAs have particular advantages in the application shown for several reasons. First, commercially available, off-the-shelf FPGAs now contain sufficient internal logic cells to perform meaningful



computational functions. Secondly, they can operate at speeds comparable to microprocessors, which eliminates the need for speed matching buffers. Still further, the internal programmable routing resources of FPGAs are now extensive enough that meaningful algorithms can now be programmed without the need to reassign the locations of the input/output ("I/O") pins.

By placing the MAP 112 in the memory subsystem or memory space, it can be readily accessed through the use of memory read and write commands, which allows the use of a variety of standard operating systems. In contrast, other conventional implementations propose placement of any reconfigurable logic in or near the processor. This is much less effective in a multiprocessor environment because only one processor has rapid access to it. Consequently, reconfigurable logic must be placed by every processor in a multiprocessor system, which increases the overall system cost. In addition, MAP 112 can access the memory array 130 itself, referred to as Direct Memory Access ("DMA"), allowing it to execute tasks independently and asynchronously of the processor. In comparison, were it were placed near the processor, it would have to compete with the processors for system routing resources in order to access memory, which deleteriously impacts processor performance. Because MAP 112 has DMA capability, (allowing it to write to memory), and because it receives its operands via writes to memory, it is possible to allow a MAP 112 to feed results to another MAP 112. This is a very powerful feature that allows for very extensive pipelining and parallelizing of large tasks, which permits them to complete faster.

Many of the algorithms that may be implemented will receive an operand and require many clock cycles to produce a result. One such example may be a multiplication that takes 64 clock cycles. This same multiplication may also need to be performed on thousands of operands. In this situation, the incoming operands would be presented

sequentially so that while the first operand requires 64 clock cycles to produce results at the output, the second operand, arriving one clock cycle later at the input, will show results one clock cycle later at the output. Thus, after an initial delay of 64 clock cycles, new output data will appear on every consecutive clock cycle until the results of the last operand appears. This is called "pipelining".

In a multiprocessor system, it is quite common for the operating system to stop a processor in the middle of a task, reassign it to a higher priority task, and then return it, or another, to complete the initial task. When this is combined with a pipelined algorithm, a problem arises (if the processor stops issuing operands in the middle of a list and stops accepting results) with respect to operands already issued but not yet through the pipeline. To handle this issue, a solution involving the combination of software and hardware is disclosed herein.

To make use of any type of conventional reconfigurable hardware, the programmer could embed the necessary commands in his application program code. The drawback to this approach is that a program would then have to be tailored to be specific to the MAP hardware. The system of the present invention eliminates this problem. Multiprocessor computers often use software called parallelizers. The purpose of this software is to analyze the user's application code and determine how best to split it up among the processors. The present invention provides significant advantages over a conventional parallelizer and enables it to recognize portions of the user code that represent algorithms that exist in MAPs 112 for that system and to then treat the MAP 112 as another computing element. The parallelizer then automatically generates the necessary code to utilize the MAP 112. This allows the user to write the algorithm directly in his code, allowing it to be more portable and reducing the knowledge of the system hardware that he has to have to utilize the MAP 112.

With reference additionally now to Fig. 4, a block diagram of the MAP control block 132 is shown in greater detail. The control block 132 is coupled to receive a number of command bits (for example, 17) from the address bus 128 at a command decoder 150. The command decoder 150 then supplies a number of register control bits to a group of status registers 152 on an eight bit bus 154. The command decoder 150 also supplies a single bit last operand flag on line 156 to a pipeline counter 158. The pipeline counter 158 supplies an eight bit output to an equality comparator 160 on bus 162. The equality comparator 160 also receives an eight bit signal from the FPGA 134 on bus 136 indicative of the pipeline depth. When the equality comparator determines that the pipeline is empty, it provides a single bit pipeline empty flag on line 164 for input to the status registers 152. The status registers are also coupled to receive an eight bit status signal from the FPGA 134 on bus 136 and it produces a sixty four bit status word output on bus 166 in response to the signals on bus 136, 154 and line 164.

The command decoder 150 also supplies a five bit control signal to a configuration multiplexer ("MUX") 170 as shown. The configuration mux 170 receives a single bit output of a 256 bit parallel-serial converter 172 on line 176. The inputs of the 256 bit parallel-to-serial converter 172 are coupled to a 256 bit user configuration pattern bus 174. The configuration mux 170 also receives sixteen single bit inputs from the configuration ROMs (illustrated as ROM 182) on bus 178 and provides a single bit configuration file signal on line 180 to the user FPGA 134 as selected by the control signals from the command decoder 150 on the bus 168.

In operation, when a processor 108 is halted by the operating system, the operating system will issue a last operand command to the MAP 112 through the use of command bits embedded in the address field on bus 128. This command is recognized by the command

decoder 150 of the control block 132 and it initiates a hardware pipeline counter 158. When the algorithm was initially loaded into the FPGA 134, several output bits connected to the control block 132 were configured to display a binary representation of the number of clock cycles required to get through its pipeline (i.e. pipeline "depth") on bus 5 136 input to the equality comparator 160. After receiving the last operand command, the pipeline counter 158 in the control block 132 counts clock cycles until its count equals the pipeline depth for that particular algorithm. At that point, the equality comparator 160 in the 10 control block 132 de-asserts a busy bit on line 164 in an internal group of status registers 152. After issuing the last operand signal, the processor 108 will repeatedly read the status registers 152 and accept any output data on bus 166. When the busy flag is de-asserted, the task can be stopped and the MAP 112 utilized for a different task. It 15 should be noted that it is also possible to leave the MAP 112 configured, transfer the program to a different processor 108 and restart the task where it left off

In order to evaluate the effectiveness of the use of the MAP 112 in a given application, some form of feedback to the use is required. 20 Therefore, the MAP 112 may be equipped with internal registers in the control block 132 that allow it to monitor efficiency related factors such as the number of input operands versus output data, the number of idle cycles over time and the number of system monitor interrupts received over time. One of the advantages that the MAP 112 has is that 25 because of its reconfigurable nature, the actual function and type of function that are monitored can also change as the algorithm changes. This provides the user with an almost infinite number of possible monitored factors without having to monitor all factors all of the time.

While there have been described above the principles of the 30 present invention in conjunction with a specific multiprocessor architecture it is to be clearly understood that the foregoing description

is made only by way of example and not as a limitation to the scope of the invention. Particularly, it is recognized that the teachings of the foregoing disclosure will suggest other modifications to those persons skilled in the relevant art. Such modifications may involve other  
5 features which are already known per se and which may be used instead of or in addition to features already described herein. Although claims have been formulated in this application to particular combinations of features, it should be understood that the scope of the disclosure herein also includes any novel feature or any novel  
10 combination of features disclosed either explicitly or implicitly or any generalization or modification thereof which would be apparent to persons skilled in the relevant art, whether or not such relates to the same invention as presently claimed in any claim and whether or not it mitigates any or all of the same technical problems as confronted by  
15 the present invention. The applicants hereby reserve the right to formulate new claims to such features and/or combinations of such features during the prosecution of the present application or of any further application derived therefrom.

**WHAT IS CLAIMED:**

1. A computer including at least one data processor for operating on user data in accordance with program instructions, said computer further including at least one memory array presenting a data and address bus, said computer comprising:

5 a memory algorithm processor associated with said memory array and coupled to said data and address buses, said memory algorithm processor being configurable to perform at least one identified algorithm on an operand received from a write operation to said memory array.

2. The computer of claim 1 wherein said memory algorithm processor comprises a field programmable gate array.

3. The computer of claim 1 wherein said memory algorithm processor is operative to access said memory array independently of said processor.

4. The computer of claim 1 wherein said at least one identified algorithm is preprogrammed into said memory algorithm processor.

5. The computer of claim 4 wherein said at least one identified algorithm is preprogrammed into a memory device associated with said memory algorithm processor.

6. The computer of claim 5 wherein said memory device comprises at least one read only memory device.

7. The computer of claim 1 further comprising a first plurality of said data processors and a second plurality of said memory arrays, each of said memory arrays comprising an associated memory algorithm processor.

8. The computer of claim 7 wherein a memory algorithm processor associated with a first one of said second plurality of said memory arrays is operative to pass a result of a processed operand to another memory algorithm processor associated with a second one of said second plurality of said memory arrays.

9. The computer of claim 1 wherein said memory algorithm processor further comprises:

a control block including a command decoder coupled to said address bus and a counter coupled to said command decoder, said command decoder for providing a last operand flag to said counter in response to a last operand command from an operating system of said at least one processor.

10. The computer of claim 9 wherein said memory algorithm processor further comprises:

an equality comparator coupled to receive a pipeline depth signal and an output of said counter for providing a pipeline empty flag to at least one status register.

11. The computer of claim 10 wherein said status register is coupled to said command decoder to receive a register control signal and a status signal to provide a status word output signal.

12. A multiprocessor computer including a first plurality of data processors for operating on user data in accordance with program instructions and a second plurality of memory arrays, each presenting a data and address bus, said computer comprising:

a memory algorithm processor associated with at least one of said second plurality of memory arrays and coupled to said data and address bus thereof, said memory algorithm processor being

configurable to perform at least one identified algorithm on an operand received from a write operation to said associated one of said second plurality of memory arrays.

13. The multiprocessor computer of claim 12 wherein said  
5 memory algorithm processor associated with one of said second plurality of memory arrays is accessible by more than one of said first plurality of data processors.

14. The multiprocessor computer of claim 13 wherein said  
10 memory algorithm processor associated with one of said second plurality of memory arrays is accessible by all of said first plurality of data processors.

15. The multiprocessor computer of claim 12 wherein said memory algorithm processor comprises:

15 a control block operative to provide a last operand flag in response to a last operand having been processed in said memory algorithm processor.

16. The multiprocessor computer of claim 12 further comprising:

20 at least one memory device associated with said memory algorithm processor for storing a number of pre-loaded algorithms.

17. The multiprocessor computer of claim 16 wherein said at least one memory device is responsive to a predetermined command to enable a selected one of said number of pre-loaded algorithms to be implemented by said memory algorithm processor.

25 18. The multiprocessor computer of claim 16 wherein said at least one memory device comprises at least one read only memory device.



19. The multiprocessor computer of claim 12 wherein said memory algorithm processor comprises a field programmable gate array.

20. The multiprocessor computer of claim 12 wherein said  
5 memory algorithm processor is accessible through normal memory access protocol.

21. The multiprocessor computer of claim 12 wherein said memory algorithm processor has direct memory access capability to said associated one of said second plurality of memory arrays.

10 22. The multiprocessor computer of claim 12 wherein a memory algorithm processor associated with a first one of said second plurality of said memory arrays is operative to pass a result of a processed operand to another memory algorithm processor associated with a second one of said second plurality of said memory arrays.

15 23. The multiprocessor computer of claim 12 wherein said computer is operative to automatically detect parallel regions of application program code that are capable of being executed in said memory algorithm processor.

20 24. The multiprocessor computer of claim 23 wherein said memory algorithm processor is configurable by said application program code.

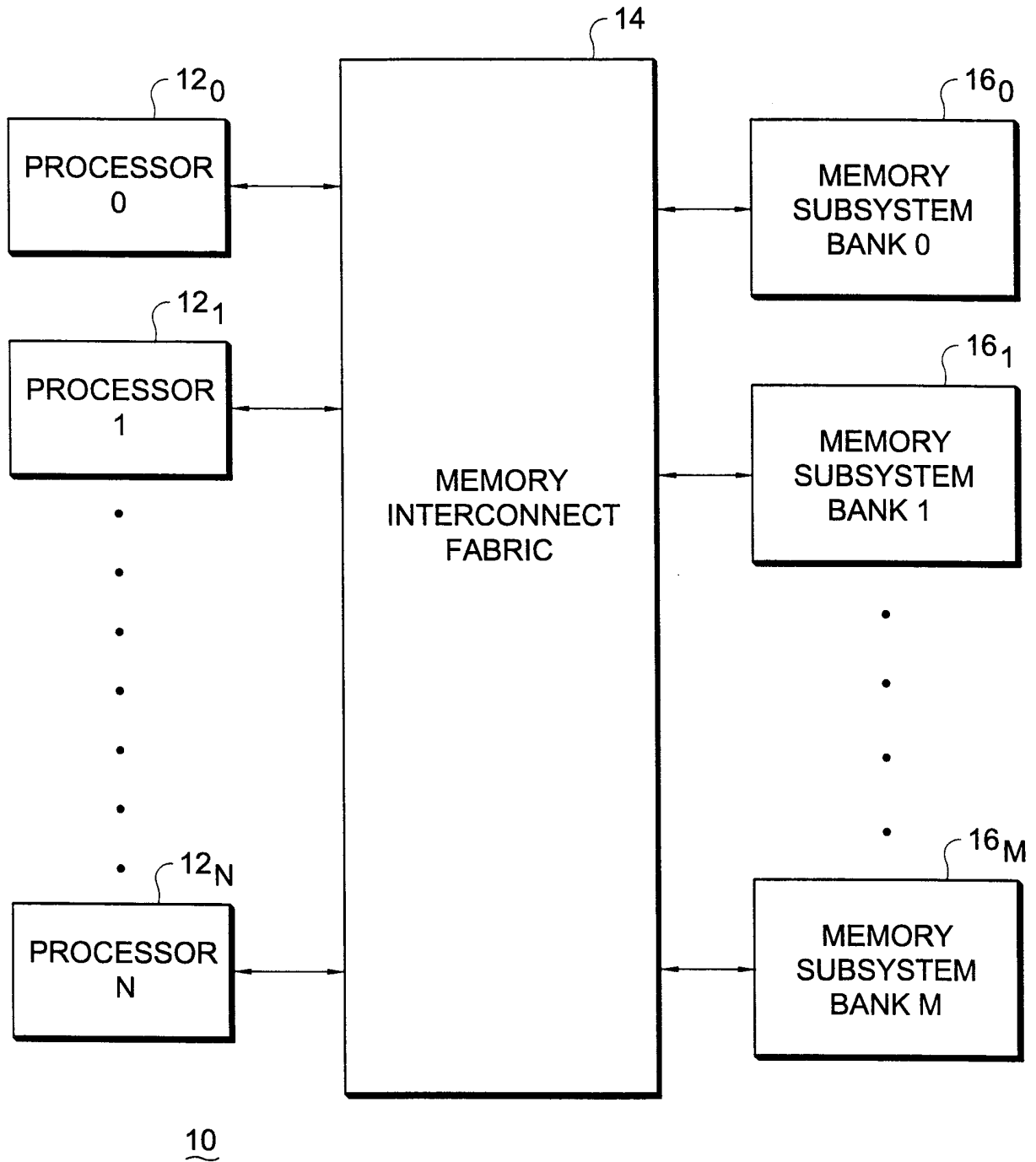

FIG. 1

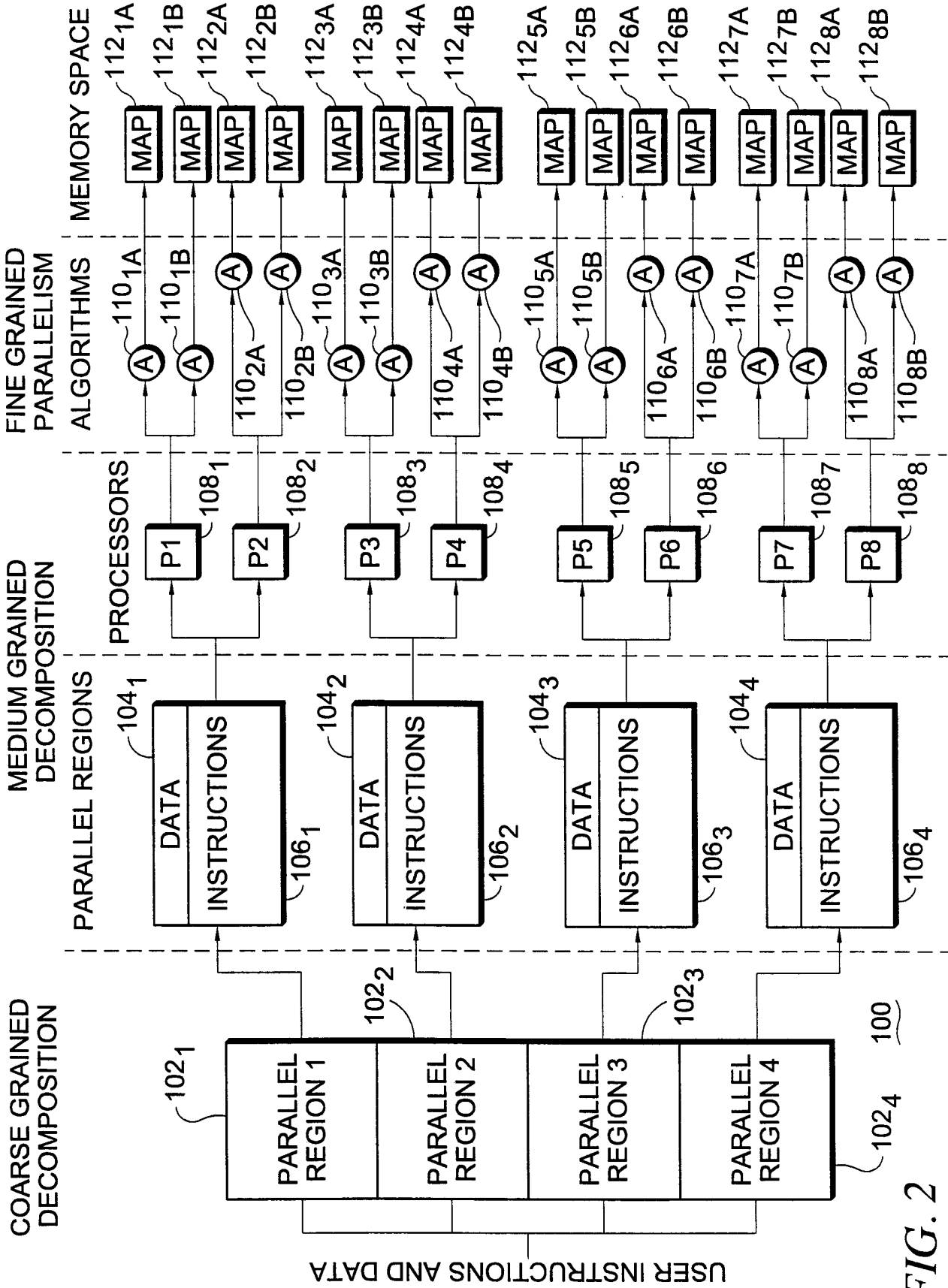
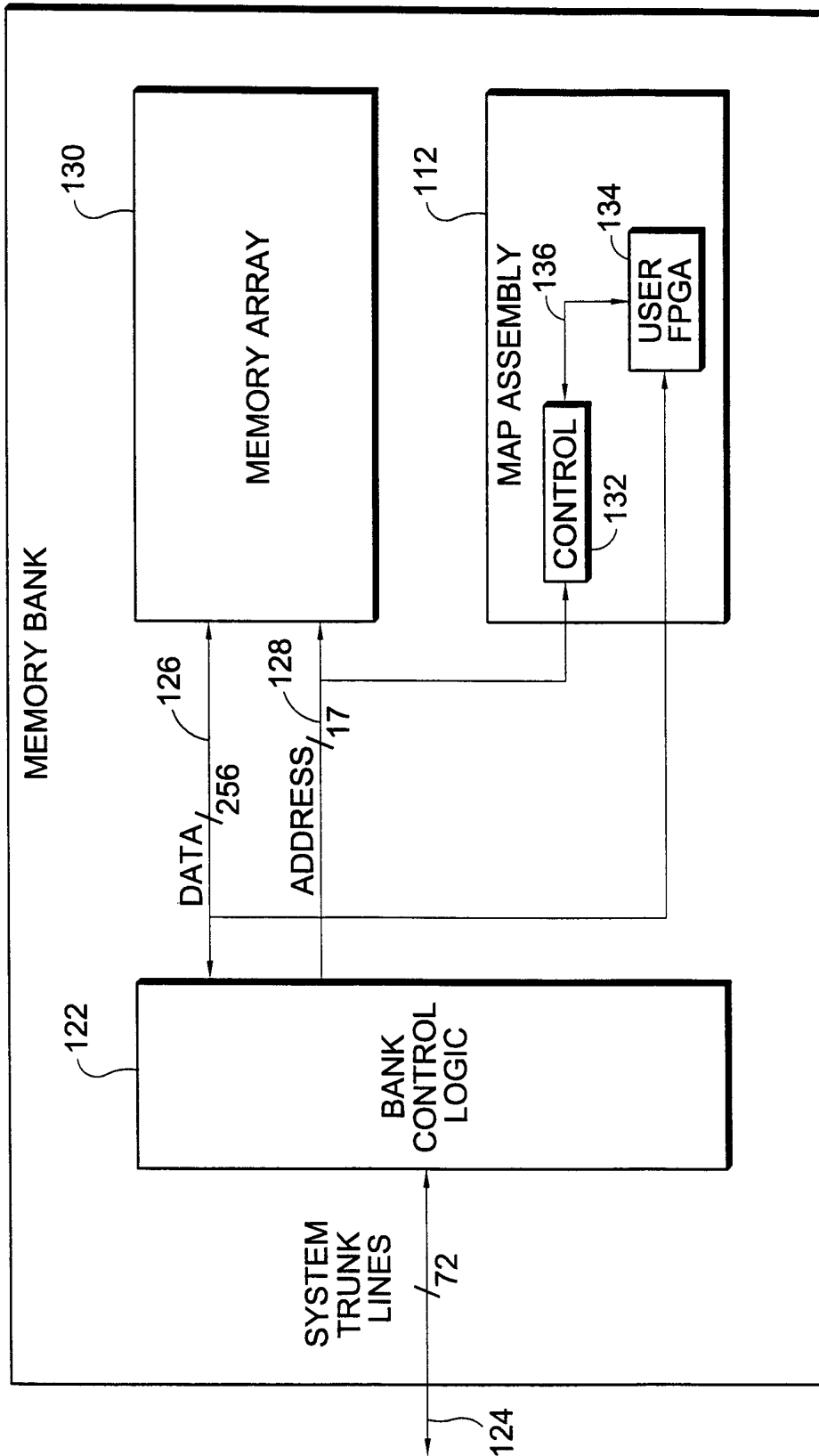

FIG. 2



120

FIG. 3

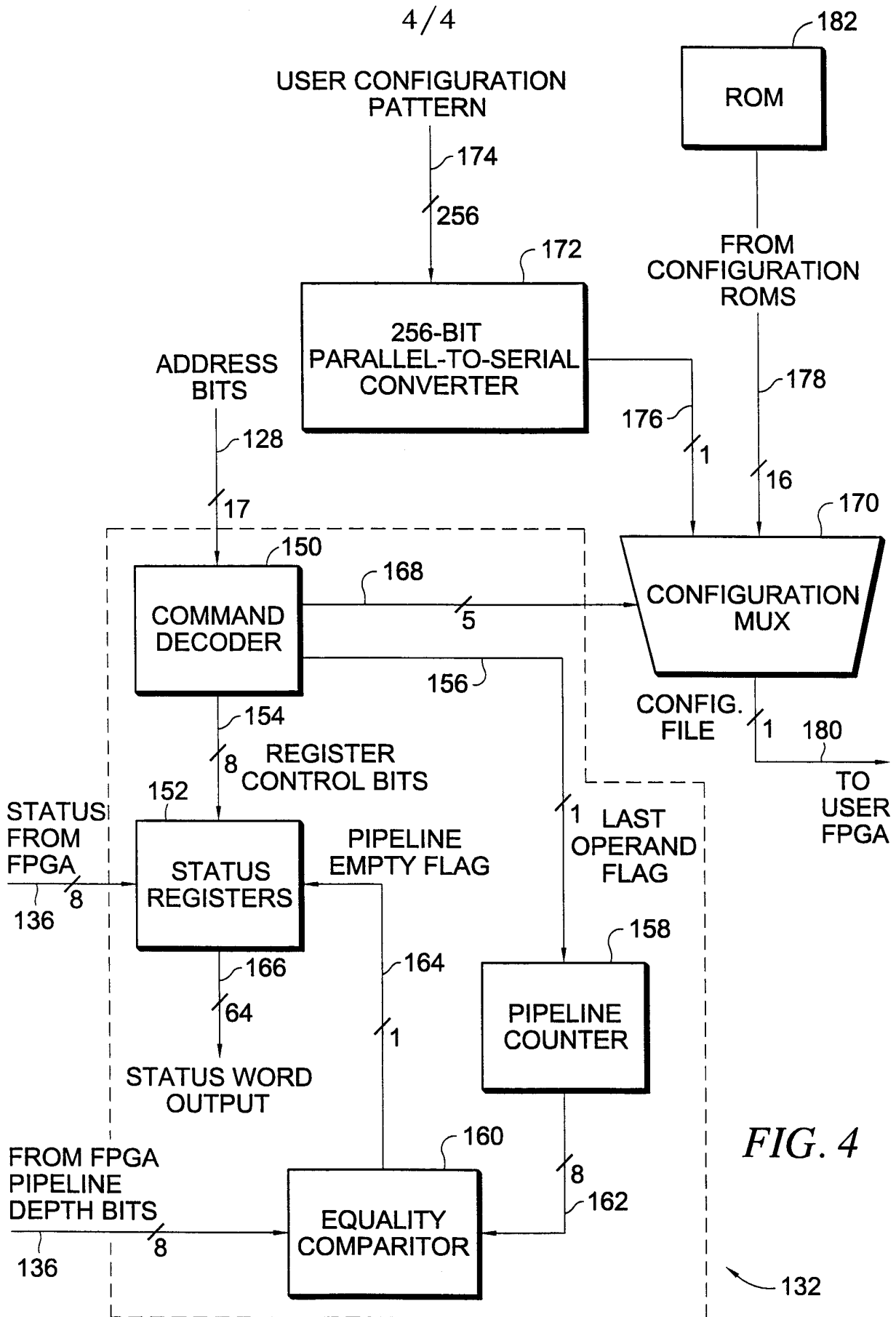

FIG. 4