



(51) International Patent Classification:

H04L 12/10 (2006.01) H04L 12/46 (2006.01)
H04L 12/40 (2006.01) H04W 88/08 (2009.01)
G06F 1/26 (2006.01) H04L 12/26 (2006.01)
H04B 3/44 (2006.01) H04L 12/24 (2006.01)

(21) International Application Number:

PCT/US2018/019365

(22) International Filing Date:

23 February 2018 (23.02.2018)

(25) Filing Language:

English

(26) Publication Language:

English

(30) Priority Data:

62/462,418 23 February 2017 (23.02.2017) US

(71) Applicant: WISER SYSTEMS, INC. [US/US]; 1017 Main Campus Dr., Suite 2300, Raleigh, North Carolina 27606 (US).

(72) Inventors: HOLLAR, Seth Edward-Austin; 2311 Bedford Avenue, Raleigh, North Carolina 27607 (US). TEDRICK, Ryan Michael; 518 Powell Dr., Raleigh, North Carolina 27607 (US). FISHER, Scott; 4727 Mill Village Rd., Raleigh, North Carolina 27612 (US).

(74) Agent: STANEK, Elizabeth A.; Ward and Smith, P.A., Wade II, Suite 400, 5430 Wade Park Boulevard, Raleigh, North Carolina 27607 (US).

(81) Designated States (unless otherwise indicated, for every kind of national protection available): AE, AG, AL, AM,

AO, AT, AU, AZ, BA, BB, BG, BH, BN, BR, BW, BY, BZ, CA, CH, CL, CN, CO, CR, CU, CZ, DE, DJ, DK, DM, DO, DZ, EC, EE, EG, ES, FI, GB, GD, GE, GH, GM, GT, HN, HR, HU, ID, IL, IN, IR, IS, JO, JP, KE, KG, KH, KN, KP, KR, KW, KZ, LA, LC, LK, LR, LS, LU, LY, MA, MD, ME, MG, MK, MN, MW, MX, MY, MZ, NA, NG, NI, NO, NZ, OM, PA, PE, PG, PH, PL, PT, QA, RO, RS, RU, RW, SA, SC, SD, SE, SG, SK, SL, SM, ST, SV, SY, TH, TJ, TM, TN, TR, TT, TZ, UA, UG, US, UZ, VC, VN, ZA, ZM, ZW.

(84) Designated States (unless otherwise indicated, for every kind of regional protection available):

ARIPO (BW, GH, GM, KE, LR, LS, MW, MZ, NA, RW, SD, SL, ST, SZ, TZ, UG, ZM, ZW), Eurasian (AM, AZ, BY, KG, KZ, RU, TJ, TM), European (AL, AT, BE, BG, CH, CY, CZ, DE, DK, EE, ES, FI, FR, GB, GR, HR, HU, IE, IS, IT, LT, LU, LV, MC, MK, MT, NL, NO, PL, PT, RO, RS, SE, SI, SK, SM, TR), OAPI (BF, BJ, CF, CG, CI, CM, GA, GN, GQ, GW, KM, ML, MR, NE, SN, TD, TG).

Published:

— with international search report (Art. 21(3))

(54) Title: SYSTEMS AND RELATED ADAPTERS FOR PROVIDING POWER TO DEVICES IN A SYSTEM

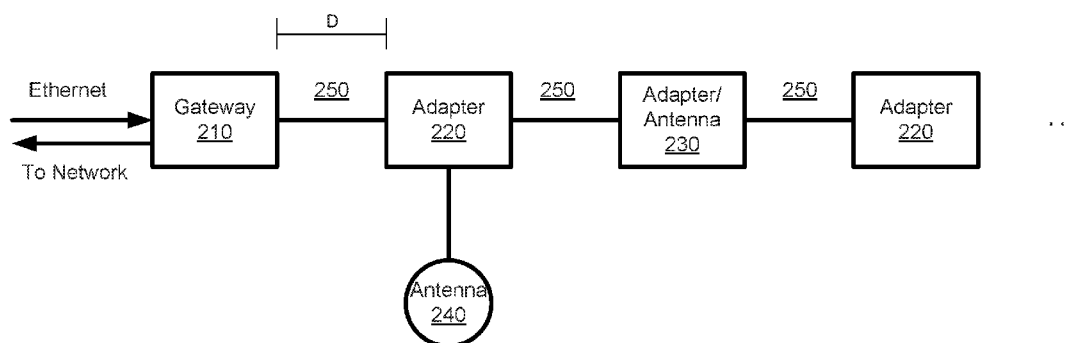

Fig. 2A

(57) Abstract: A system for providing power to a device (240, 230) is provided. The system includes at least one gateway (210) that provides power and/or data to at least one device (240, 230) in the system; and at least one adapter (220, 230) coupled to the gateway (210) and the at least one device (240, 230), wherein the adapter (220, 230) is configured to couple lengths of cable (250) between devices (240, 230) that are daisy chained together. Related adapters (220, 230) are also provided herein.



SYSTEMS AND RELATED ADAPTERS FOR PROVIDING POWER TO DEVICES IN A SYSTEM

CLAIM OF PRIORITY

[0001] The present application claims priority to United States Provisional Patent Application No. 62/462,418, filed on February 23, 2017, entitled *Gateways and Related Adapters Powered Over Ethernet* (Attorney Docket No. 071021-00018PR), the disclosure of which is hereby incorporated herein by reference as if set forth in its entirety.

FIELD

[0002] The present inventive concept relates generally antennas and, more particularly, to supplying power to antennas and related devices, methods and systems.

BACKGROUND

[0003] Devices that are powered conventionally, *i.e.*, by being plugged into a wall receptacle or portable power supply, are limited to use in environments where such conventional power supplies are available. As wireless communications become the wave the future throughout the world, more creative ways of powering infrastructure to support these communications is desired.

SUMMARY

[0004] Some embodiments of the present inventive concept provide a system for providing power to a device. The system includes at least one gateway that provides power and/or data to at least one device in the system over a single cable; and at least one adapter coupled to the gateway and the at least one device using the single cable, wherein the adapter is configured to couple lengths of the single cable between devices that are daisy chained together.

[0005] In further embodiments, the at least on device may be an antenna and the adapter may be coupled to the antenna that is powered by the system.

[0006] In still further embodiments, at least one of the at least one adapters may be a combination adapter and antenna.

[0007] In some embodiments, the at least one device may include a plurality of antennas and/or antenna-adapter combinations and the at least one gateway, the at least one adapter and the plurality of antennas and/or antenna-adapter combinations may be coupled using the single cable configured to provide power and/or data.

[0008] In further embodiments, the at least one gateway, the at least one adapter and the plurality of antennas and/or antenna-adapter combinations may be separated by a distance of no greater than one hundred feet and the plurality of antennas and/or antenna-adapter combinations may include up to at least ten.

[0009] In still further embodiments, the adapter may further include a power switch that is configured to be remotely triggered allowing devices to be switched on and off at different times to avoid large voltage bounces that disrupt the system.

[0010] In some embodiments, the at least one gateway and/or the at least one adapter may be configured to store data related to health of the system and communicate the stored data automatically at a predetermined time or upon request by another device.

[0011] In further embodiments, the at least one gateway may be further configured to receive data from the at least one device in the system.

[0012] In still further embodiments, the at least one gateway may further include a universal serial bus (USB) connection configured to connect to a device to increase a number of devices in the system.

[0013] In some embodiments, the at least one gateway may be further configured to perform an automatic detection algorithm to discover all devices in the system.

[0014] In further embodiments, the gateway may be an Ethernet gateway.

[0015] Still further embodiments of the present inventive concept provide an adapter for providing power to a plurality of devices in a system using a single cable. The adapter is coupled to a gateway that provides power and/or data to the plurality of devices using the single cable and is configured to couple lengths of the single cable between devices that are daisy chained together.

BRIEF DESCRIPTION OF THE DRAWINGS

[0016] Fig. 1 is a block diagram an antenna in accordance with some embodiments of the present inventive concept.

[0017] Fig. 2A is a block diagram of a system including a gateway and adapters in accordance with some embodiments of the present inventive concept.

[0018] Fig. 2B is a more detailed block diagram of a gateway in accordance with some embodiments of the present inventive concept.

[0019] Fig. 2C is a more detailed block diagram of an adapter in accordance with some embodiments of the present inventive concept.

[0020] Fig. 3 is a block diagram of a system in accordance with embodiments of the present inventive concept configured to function in a large warehouse environment.

[0021] Fig. 4 is a diagram of an antenna in accordance with embodiments discussed herein configured to be attached to a cable as shown in Fig. 3.

[0022] Fig. 5 is a diagram illustrating an antenna attached to a cable in accordance with some embodiments.

[0023] Figs. 6A and 6B are perspective and side views of a single side of the connector in accordance with some embodiments of the present inventive concept.

[0024] Fig. 7 is a block diagram of an antenna in accordance with some embodiments of the present inventive concept.

DETAILED DESCRIPTION

[0025] The present inventive concept will be described more fully hereinafter with reference to the accompanying figures, in which embodiments of the inventive concept are shown. This inventive concept may, however, be embodied in many alternate forms and should not be construed as limited to the embodiments set forth herein.

[0026] Accordingly, while the inventive concept is susceptible to various modifications and alternative forms, specific embodiments thereof are shown by way of example in the drawings and will herein be described in detail. It should be understood, however, that there is no intent to limit the inventive concept to the particular forms disclosed, but on the contrary, the inventive concept is to cover all modifications, equivalents, and alternatives falling within the spirit and

scope of the inventive concept as defined by the claims. Like numbers refer to like elements throughout the description of the figures.

[0027] The terminology used herein is for the purpose of describing particular embodiments only and is not intended to be limiting of the inventive concept. As used herein, the singular forms "a", "an" and "the" are intended to include the plural forms as well, unless the context clearly indicates otherwise. It will be further understood that the terms "comprises", "comprising," "includes" and/or "including" when used in this specification, specify the presence of stated features, integers, steps, operations, elements, and/or components, but do not preclude the presence or addition of one or more other features, integers, steps, operations, elements, components, and/or groups thereof. Moreover, when an element is referred to as being "responsive" or "connected" to another element, it can be directly responsive or connected to the other element, or intervening elements may be present. In contrast, when an element is referred to as being "directly responsive" or "directly connected" to another element, there are no intervening elements present. As used herein the term "and/or" includes any and all combinations of one or more of the associated listed items and may be abbreviated as "/".

[0028] Unless otherwise defined, all terms (including technical and scientific terms) used herein have the same meaning as commonly understood by one of ordinary skill in the art to which this inventive concept belongs. It will be further understood that terms used herein should be interpreted as having a meaning that is consistent with their meaning in the context of this specification and the relevant art and will not be interpreted in an idealized or overly formal sense unless expressly so defined herein.

[0029] It will be understood that, although the terms first, second, etc. may be used herein to describe various elements, these elements should not be limited by these terms. These terms are only used to distinguish one element from another. For example, a first element could be termed a second element, and, similarly, a second element could be termed a first element without departing from the teachings of the disclosure. Although some of the diagrams include arrows on communication paths to show a primary direction of communication, it is to be understood that communication may occur in the opposite direction to the depicted arrows.

[0030] As discussed above, conventional methods of powering a device may lead to limited uses for the device as the world moves towards wireless devices and communications. Thus, some embodiments of the present inventive concept provide methods, systems and devices to

provide power over cables to a plurality of devices without having multiple power drops or using batteries that have to be routinely replaced. For example, in some embodiments, power is provided to a plurality of devices over Ethernet. However, it will be understood that embodiments of the present inventive concept are not limited to this configuration. Furthermore, although embodiments of the present inventive concept are directed to providing power to antennas over Ethernet, embodiments of the present inventive concept are not limited to this configuration as will be discussed further below with respect to Figs. 1 through 7.

[0031] Referring first to Fig. 1, an example antenna that can be used in combination with gateways and adapters in accordance with some embodiments of the present inventive concept will be discussed. As illustrated in Fig. 1, the antenna includes a radiating element 201, a conducting tab 202, connection points 203 and wires 204 connected thereto, a printed circuit board (PCB) 205 and a hole 206 in the PCB 205. As further illustrated, the radiating element 201 is orthogonal to the PCB 205. The hole 206 in the PCB 205 provides a pathway for the radiating element 201 to connect to RF circuitry (not shown) on the PCB 205 via the narrow conducting tab 202. It will be understood that electronics can be placed on a top or bottom surface of the PCB 205 without departing from the scope of the present inventive concept. In some embodiments, the hole 206 in the PCB 205 may be metalized, for example, coated with a metal. In these embodiments, the tab 202 can be soldered directly to the hole 206 to make both an electrical and mechanical connection. In some embodiments, the radiating element is mechanically held to the PCB board with glue applied to the tab area for additional strength. Non-conductive glue may be applied near the hole and tab area to hold the radiating element in place.

[0032] The radiating element 201 can include, for example, electrically conductive material, such as copper and silver. Although the antenna in Fig. 1 is illustrated as a round antenna, embodiments of the present inventive concept are not limited to this configuration. For example, the antenna can take any shape to achieve the desired antenna pattern without departing from the scope of the present inventive concept. Anisotropic antenna patterns can also be created by changing the shape and size of the radiating element 201 and/or the PCB 205. In some embodiments, the radiating element 201 maybe round except for a small tab 202 at the bottom as illustrated in Fig. 1. The width of the tab 202 and thickness of the metal can be chosen such that the tab 202 fits through a hole 206 in the PCB 205. Examples of various embodiments of the

antennas that may be used is discussed, for example, in International Application No. PCT/US2016/061075, the disclosure of which is hereby incorporated herein by reference as if set forth in its entirety.

[0033] Electrical power and data are run through the plurality of wires 204 that connect to the PCB 205 at the connection points 203. The plurality of wires 204 can, for example, be soldered directly to the board, attached with a connector and the like. In some embodiments, the plurality of wires 204 protrude from a side portion of the PCB 205. In some embodiments, the plurality of wires 204 may run away from the board such that the plurality of wires 204 and a face of the radiating element 201 lie in the same plane. These embodiments may further reduce any distortion to the isotropic antenna pattern. Furthermore, in addition to power, additional data lines can run out of the PCB 205. In some embodiments, the data and power lines can serve as lines for a universal serial bus (USB) connection. In some embodiments, lines for a universal asynchronous receiver/transmitted (UART) can be used. The connector could be any number of standard power connectors. In some embodiments, the connector is a standard 120V AC wall plug. In further embodiments, the connector is any type of light bulb socket. Although not illustrated in Fig. 1, in some embodiments, a battery may be integrated onto the PCB 205. In these embodiments, the plurality of wires 204 and associated connectors 203 may or may not be necessary since power is provided by the battery.

[0034] However, as discussed above, the standard power options may be not be reasonable for providing wireless communications in an area, building or country where the standard power options are not readily available. Thus, as will be discussed below, some embodiments of the present inventive concept provide a gateway in combination with an adapter that enables multiple devices to be daisy chained together to cover a significant distance and be powered by/through the cable therebetween, for example, an Ethernet cable. As used herein, "daisy chained" refers to connecting two or more devices together in a linear series.

[0035] It will be understood that the antenna illustrated in Fig. 1 is provided for example only and embodiments discussed herein are not limited thereto. For example, an antenna on a PCB in accordance with further embodiments of the present inventive concept will be discussed with respect to Fig. 7. As illustrated in Fig. 7, the elements of the antenna are provided on a PCB 103. The antenna elements include a ground plane 101 for the antenna, a radiating element 102 of the antenna, a ground plane 104 for the radio frequency (RF) electronics, a stripline 105

electrically connecting the radiating element 102 to RF electronics 106 on the PCB 103 and a ground connect 107 between the ground plane for the antenna 101 and the ground plane for the RF electronics 104.

[0036] As further illustrated, the antenna system further includes jacks 701 and 704 on either side of the PCB 103. These jacks 701 and 704 may be, for example, RJ45 Ethernet jacks, however embodiments of the present inventive concept are not limited to this configuration. In particular, Ethernet jacks 701 and 704 may connect to PCB board 103 and cables 702 and 703 may provide power and data communication capabilities. For example, cable 702 may provide the power to the antenna device along with providing two-way communication. Similarly, cable 703 may provide power from the antenna device to the next one along the daisy chain as discussed further herein with respect to Fig. 2A.

[0037] Referring now to Fig. 2A, a system in accordance with some embodiments of the present inventive concept including a gateway, adapters, antenna and combination adapter/antenna will be discussed. As illustrated in Fig. 2A, the system 200 includes a gateway 210, an adapter 220 coupled to an antenna 240, and a combination antenna and adapter 230. It will be understood that system of Fig. 2A is provided as an example only and that more or less of each element may be provided without departing from the scope of the present inventive concept. As indicated by the ellipses in Fig. 2A, more devices may be daisy chained together to provide coverage over a substantial distance. In some embodiments, ten or more devices may be connected together without departing from the scope of the present inventive concept.

[0038] In particular, the gateway 210 may be an Ethernet gateway that is configured to receive Ethernet and provide data and power via cables 250 to the antennas 240, the adapters 220 and combination units 230. The Ethernet may be 10/100 Base-Y Ethernet in some embodiments. For example, the cable 250 may be a Category 5 (Cat5) cable using RS-422, but is not limited to this configuration. For example, the cable may use RS-485 without departing from the scope of the present inventive concept. The distance D between units may be customized as needed and in some embodiments may be up to 100 feet. Thus, in some embodiments when ten devices are daisy chained with 100 feet between them, a large area may be covered without using conventional power receptacles.

[0039] As discussed above, the gateway 210 may provide data and power to the devices connected thereto, but may also receive data from the devices in the system. The data provided

by the devices (antennas) may be used for location purposes. In some embodiments, data can be sent directly to the Ethernet gateway over the cables directly to a server (location server) such that the antenna band (UWB RF band) can be used mostly for location purposes instead of generic data transmission. Furthermore, as illustrated in Fig. 2B, in some embodiments a gateway 210 may include a USB connection 212 such that the gateway 210 may also host an antenna. Including the USB connection 212 in the gateway 210 adds versatility to the system by allowing the addition of one more antenna to the network without the addition of another adapter.

[0040] In some embodiments, the gateways 210 may be configured to perform an auto-detection algorithm to detect both antennas and adapters directly connected to the ports thereof. Having the gateway perform the discovery operation may be faster than detecting the antennas from a remote client device. Furthermore, in systems having the correct amount of processing resources at the Central Processing Unit (CPU), the gateway may be configured to run all algorithms necessary to control the connected antennas. Furthermore, in some embodiments, the gateway 210 can act as a rest application program interface (API) server to provide location data (x,y,z) to remote clients.

[0041] The gateway 210 may be coupled to the cable 250 via any means known to those having skill in the art, for example, via a universal serial bus (USB) connection. The gateway 210 allows selection of ports and packet schemes for communication, for example, UDP and TCP, and also provides various methods of encryption for the data being communicated. In some embodiments, the throughput of the system may be about 4 megabits per second.

[0042] Although embodiments are discussed herein as using Ethernet to power antennas and adapters for a particular system, embodiments of the present inventive concept may not be limited to this configuration. For example, systems, devices and methods discussed herein may be used to provide power to anything that needs power, for example, whole house power without departing from the scope of the present inventive concept.

[0043] As discussed above, the adapter 220 is connected to the gateway 210 over a cable 250, for example, a Cat5 Ethernet cable. The adapter 220 is configured to connect to an antenna 240 that receives location information in accordance with location systems provided by Wiser Systems. The location information may be provided over the air by the antenna 240 or over the cable 250 in some embodiments. Some embodiments provide a combined antenna/adapter 230

so that an external antenna 240 is not necessary. The adapters allow lengths of cable 250 having a distance D to be connected together through the adapter 220 in daisy chain. In some embodiments, up to ten devices can be daisy chained together. As discussed above with respect to the gateway 210, the adapter 220 and the adapter/antenna 230 can be connected to the cable 250 using any known method. However, in some embodiments, the cable 250 connected using a USB connection.

[0044] As illustrated in, Fig. 2C, in some embodiments the adapter 220 may include a power switch 224 that may be used to turn on and off the transceiver 222. The power switch 224 allows the transceivers to be turned on at different time and not all at once. If all the transceivers 222 are turned on at the same time, a big voltage bounce may occur, which can be detrimental to the electronics. Accordingly, to reduce the magnitude of the voltage bounce, in some embodiments a slight delay is induced between powering on each transceiver. The transceivers 222 may be turned on using a command communicated along the cable to the adapter to turn on and off the power. Furthermore, providing the power switch 224 in the adapter may allow the antennas to be remotely reset via the adapter if necessary, for example, if the antennas freeze and need to be rebooted.

[0045] Thus, in some embodiments, adapters 220 may provide a means to communicate with and power an antenna. The antenna may be a standalone antenna or a combination adapter/antenna. Adapters may be powered by and can send/receive data from a single cable, for example, Ethernet cable. However it will be understood that an Ethernet protocol may not be used. In some embodiments, the adapter 220 has an out connector for powering and sending data to additional adapters through the single cable. As discussed, adapters 220 have the ability to be affixed to walls, ceilings, and the like, in open, high areas where the antennas need to operate but typically do not have access to conventional power sources. Furthermore, in some embodiments, the adapters 220 may be included in existing lights, exit signs, other powered devices affixed to walls, ceilings, windows, doors and the like without departing from the scope of the present inventive concept.

[0046] As further illustrated in Figs. 2B and 2C, the gateways 210 and adapters 220 may include memory 213 and 223, respectively. This memory 213 and 223 may be used to store data, such as data rate, error rate, voltage swings, and the like that may give the user an indication of the health of the system. This information may be reported from the gateway 210 and/or adapter

220 upon request via a communication channel. This data can be used to discern potential issues with connections/cable lengths/ baud rates and the like before the issue becomes catastrophic.

Firmware in the gateways/adapters may be remotely updated in accordance with some embodiments.

[0047] It will be understood that gateways and/or adapters in accordance with embodiments discussed herein may take many forms without departing from the scope of the present inventive concept. For example, a gateway may be used as a part of a client server model or the gateway may be used as a REST API server and the gateway can provide location data to remote clients. In some embodiments, gateways may be configured to discover the configuration of adapter/antenna network.

[0048] Some embodiments use a non-stateful addressing schema to allow adapters to communicate with the gateway and be used without any setup, as well as be reordered and swapped out without extra configuration. In some embodiments, gateways communicate with adapters without requiring the adapters to save the state of their address. For example, the gateway sends a command along the port telling it to go to the 'n'th adapter. For each consecutive receiving adapter, it reads the 'n' value and then decrements the 'n' value. If the 'n' value is not zero, it sends it on to the next adapter. If it is zero, then it sends it to the connected antenna. Not only can the adapter relay the message to its connected antenna but the adapter can also make a determination that the message was for itself and then act on the command/request based on the message contents.

[0049] In some embodiments, the combination units and adapters may have a backup power means associated therewith to allow power to be maintained in the event that the Ethernet fails. For example, each device may be provided with a backup battery that will maintain power for a predetermined period of time, for example, two hours.

[0050] As will be understood not all environments lend themselves to have electronic equipment set up in various locations. For example, a large warehouse or manufacturing environment may not have locations where electronic equipment can be readily positioned. A block diagram of an example configuration in a warehouse environment will be discussed with respect to Fig. 3. As illustrated therein, a cable 360, for example, a steel cable, can be strung between two pillars 375 in a warehouse environment. The cable 250 from the Ethernet gateway (Fig. 2A) can be run along the steel cable 260 through the adapters 220 and the combination

units 230. As illustrated in Fig. 3, some of the adapters have antennas 240 attached thereto and others do not. In some embodiments, the voltage in the cables may be greater than 10 Volts, for example, 24V, which may reduce the power loss over the cables. In some embodiments, the adapters include a step down DC/DC converter to convert the voltage received to a typical digital voltage (ex. 5V and/or 3.3V). It will be understood that although embodiments are discussed herein with respect to DC voltage, embodiments of the present inventive concept are not limited thereto. AC voltage may be used without departing from the scope of the present inventive concept.

[0051] It will be understood that there is a relationship between the length of the line (cable) and the speed of transmission. Some embodiments of the present inventive concept are configured to dynamically change the baud rate based on the length of the line. The baud rate is the rate at which information is transferred in a communication channel. In these embodiments, a length of the line may be measured using, for example, two adjacent antennas (UWB) to measure their absolute distance which gives some insight into the total line length. Alternatively, in some embodiments, two adapters may be configured to send a plurality of packets to one another and measure the error rate of the packets. Baud rates can be adjusted until a tolerable error rate is achieved. An algorithm can be used to dynamically switch from a "safe" slow baud rate to a faster baud rate which may or may not work and then back to a "safe" one again. As used herein, a "safe" baud rate refers to a baud rate in which the error rate of the packets is negligible. In other words, a safe baud rate would be one that reduces, or possibly minimizes or totally mitigates, errors in the transmission channel. Generally if a bit gets flipped the entire message is discarded, which will usually result in resending the message or a portion of data being lost. A safe baud rate reduced the likelihood that this will happen.

[0052] It will be understood that any means known to those having skill in the art may be used to attach the adapters 220, the combination units 230 and the antennas 240. For example, in some embodiments a mount may be provided to connect to the antenna around the cable 360. For example, as illustrated in Fig. 4, an antenna 240 is coupled to a cable 360 using a connector 485. The connector 485, provided as an example only, has a clasp design. In particular, the connector 485 has two plates that join together to clasp the antenna 240 and cable 360 together. In some embodiments, the two halves of the connector 485 are configured to meet and be

screwed in place so that the two halves clasp around the cable 360 and hold the antenna in place on the cable.

[0053] An example connector 485 is illustrated in Fig. 5 on a cable 360. As illustrated in Fig. 5, the connector 485 had two pieces 485A and 485B that grip the cable 360 and the antenna therebetween. Referring to Figs. 6A and 6B, a perspective and side view, respectively, of one half the connector are illustrated. The corresponding half would mirror these.

[0054] Example specifications for the gateway and the adapter in accordance with some embodiments will be provided. However, embodiments of the present inventive concept are not limited thereto. The gateway may have an input voltage of from about 37 to about 57 volts; an output voltage of about 24 volts; and a current of up to about 375mA. The standard conformed to may be IEEE802.3af and the enclosure for the gateway may have the following dimensions 3.6 inches x 2.6 inches x 1.1 inches. Similarly, the adapter may have a voltage of about 24 volts; a current of about 4mA without a USB device and 30mA with a USB device and be connected to other devices using RS422. The dimensions of the adapter enclosure may be 2.6 inches x 2.6 inches x 1.1 inches. It will be understood that the details discussed herein are provided for example only and that embodiments of the present inventive concept are not limited thereto. For example, voltages measured in both alternative current (AC) and direct current (DC) may be used without departing from the scope of the present inventive concept.

[0055] As briefly discussed above, some embodiments of the present inventive concept provide an Ethernet gateway that provides both power and data to/from antennas in a system. The antennas may be daisy chained together using adapters associated therewith. Thus, embodiments of the present inventive concept may be adapted to provide wireless communications between devices without having to provide a conventional power source for each device in the system.

[0056] Thus, some embodiments of the present inventive concept allow adapters to be separated by much longer lengths of cable (for example, up to 100 feet), which lends itself to antennas as they are generally placed relatively far apart. Conventional systems including, for example, USB hubs generally cannot support such lengths. Furthermore, embodiments of the present application further allow much higher voltages over the cable compared to conventional USB systems, which allows power to be transferred at less of a loss.

[0057] In the drawings and specification, there have been disclosed exemplary embodiments of the inventive concept. However, many variations and modifications can be made to these embodiments without substantially departing from the principles of the present inventive concept. Accordingly, although specific terms are used, they are used in a generic and descriptive sense only and not for purposes of limitation, the scope of the inventive concept being defined by the following claims.

WHAT IS CLAIMED IS:

1. A system for providing power to a device, the system comprising:
at least one gateway that provides power and/or data to at least one device in the system over a single cable; and
at least one adapter coupled to the gateway and the at least one device using the single cable, wherein the adapter is configured to couple single lengths of cable between devices that are daisy chained together.
2. The system of Claim 1, wherein the at least on device comprises an antenna and wherein the adapter is coupled to the antenna that is powered by the system.
3. The system of Claim 2, wherein at least one of the at least one adapters comprises a combination adapter and antenna.
4. The system of Claim 2:
wherein the at least one device comprises a plurality of antennas and/or antenna-adapter combinations; and
wherein the at least one gateway, the at least one adapter and the plurality of antennas and/or antenna-adapter combinations are coupled using the single cable configured to provide power and/or data.
5. The system of Claim 4, wherein the at least one gateway, the at least one adapter and the plurality of antennas and/or antenna-adapter combinations are separated by a distance of no greater than one hundred feet and wherein the plurality of antennas and/or antenna-adapter combinations comprises up to at least ten.
6. The system of Claim 1, wherein the adapter further comprises a power switch that is configured to be remotely triggered allowing devices to be switched on and off at different times to avoid large voltage bounces that disrupt the system.

7. The system of Claim 1, wherein the at least one gateway and/or the at least one adapter is configured to store data related to health of the system and communicate the stored data automatically at a predetermined time or upon request by another device.

8. The system of Claim 1, wherein the at least one gateway is further configured to receive data from the at least one device in the system.

9. The system of Claim 1, wherein the at least one gateway further comprises a universal serial bus (USB) connection configured to connect to a device to increase a number of devices in the system.

10. The system of Claim 1, wherein the at least one gateway is further configured to perform an automatic detection algorithm to discover all devices in the system.

11. The system of Claim 1, wherein the gateway is an Ethernet gateway.

12. An adapter for providing power to a plurality of devices in a system over a single cable, the adapter being coupled to a gateway that provides power and/or data to the plurality of devices using the single cable and configured to couple lengths of the single cable between devices that are daisy chained together.

13. The adapter of Claim 12, wherein the plurality of devices comprises antennas and wherein each antenna has an associated adapter coupled to the antenna that is powered by the system.

14. The adapter of Claim 12, wherein the adapter comprises a combination adapter and antenna.

15. The adapter of Claim 12, wherein the gateway, the adapter and the plurality of devices are coupled using the single cable configured to provide power and/or data to the plurality of devices.

16. The adapter of Claim 12, wherein the gateway, the adapter and the plurality of devices are separated by a distance of no greater than one hundred feet and wherein the plurality of devices comprises up to at least ten.

17. The adapter of Claim 12, wherein the adapter further comprises a power switch that is configured to be remotely triggered allowing the plurality of devices to be switched on and off at different times to avoid large voltage bounces that disrupt the system.

18. The adapter of Claim 12, wherein the gateway and/or the adapter is configured to store data related to health of the system and communicate the stored data automatically at a predetermined time or upon request by another device.

19. The adapter of Claim 12, wherein the gateway is an Ethernet gateway.

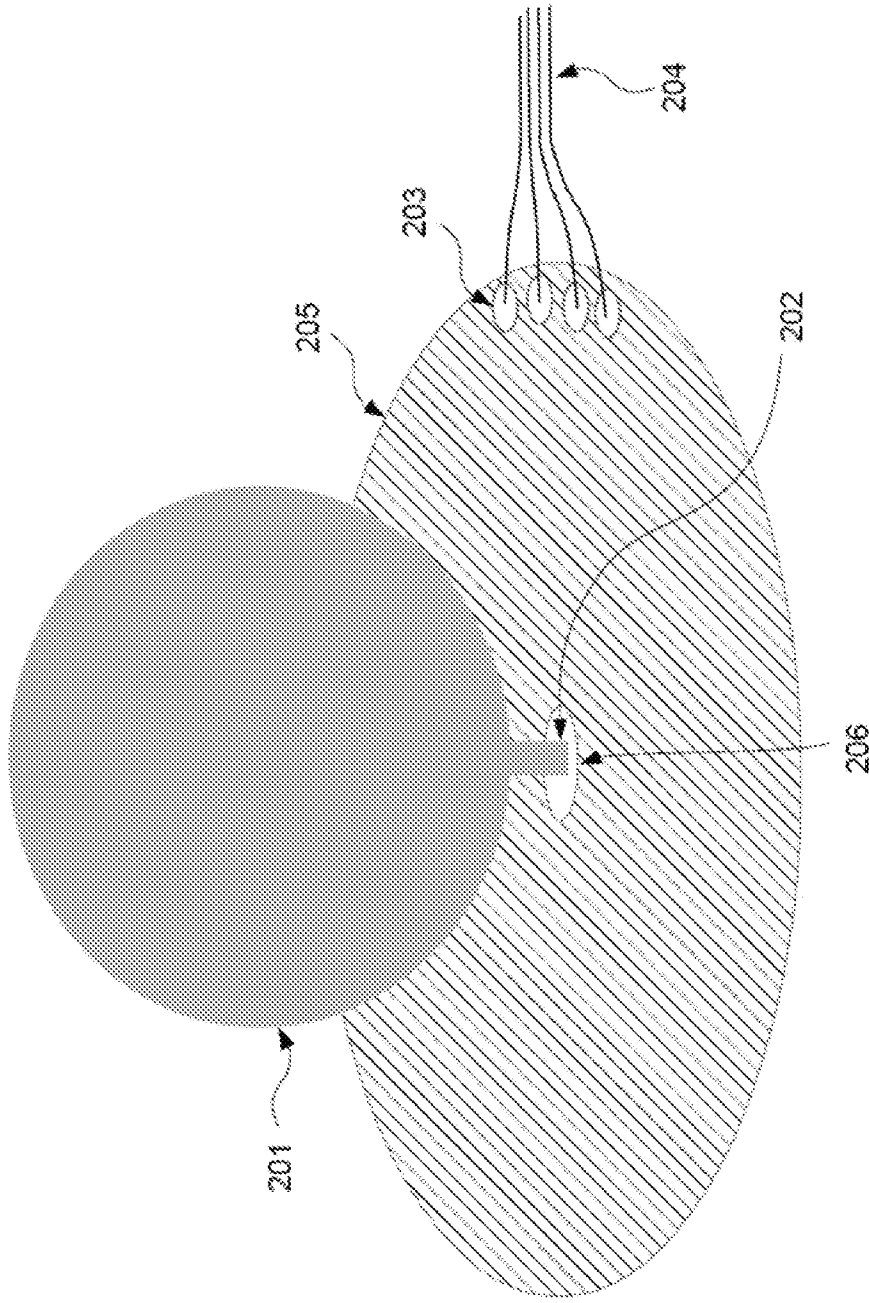

Fig. 1

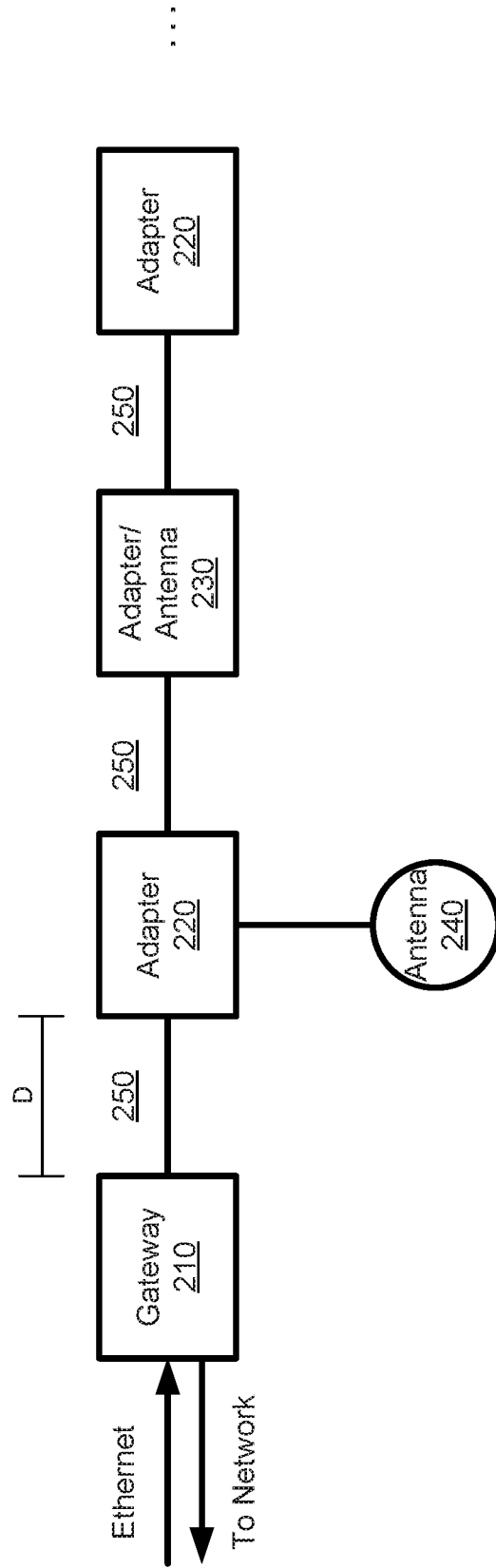

Fig. 2A

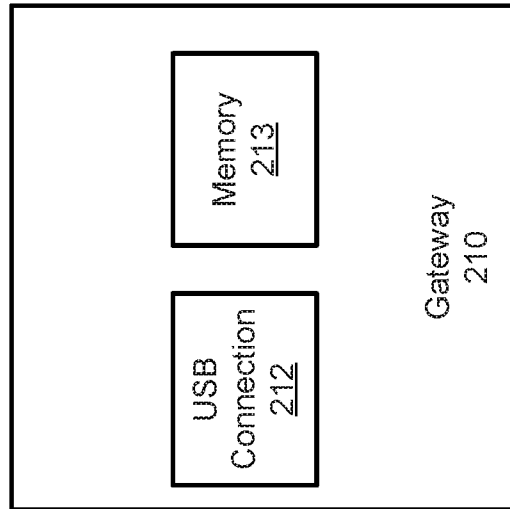

Fig. 2B

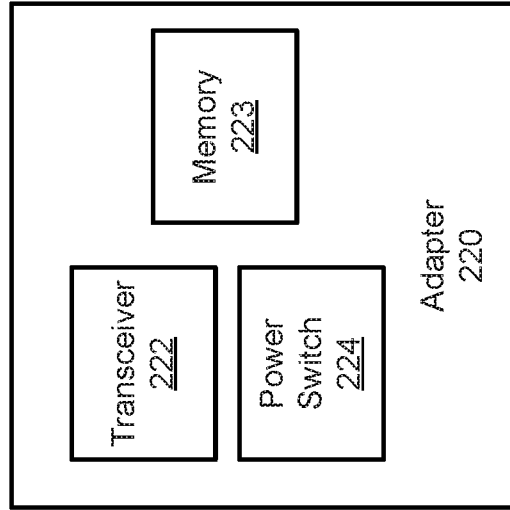

Fig. 2C

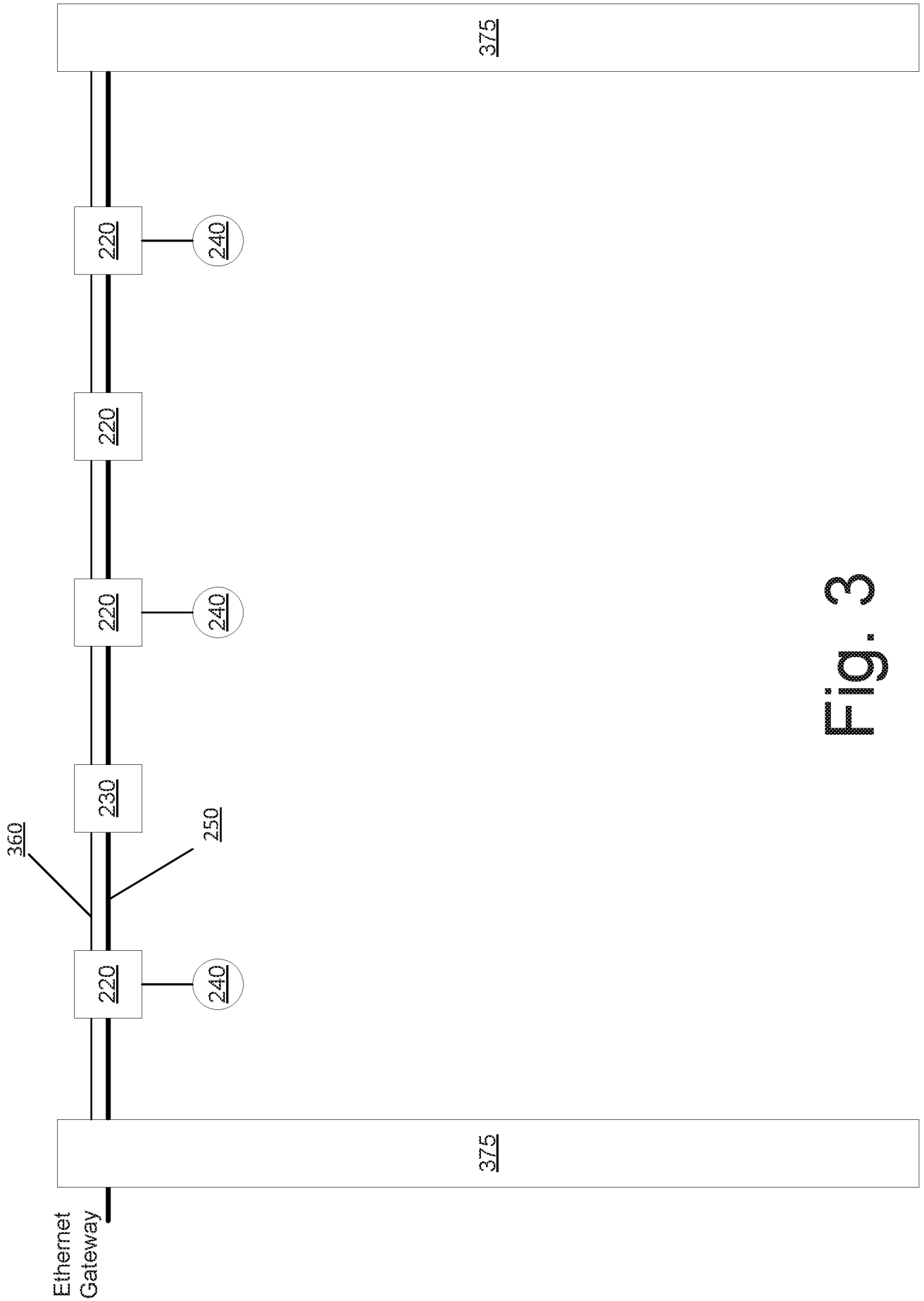

Fig. 3

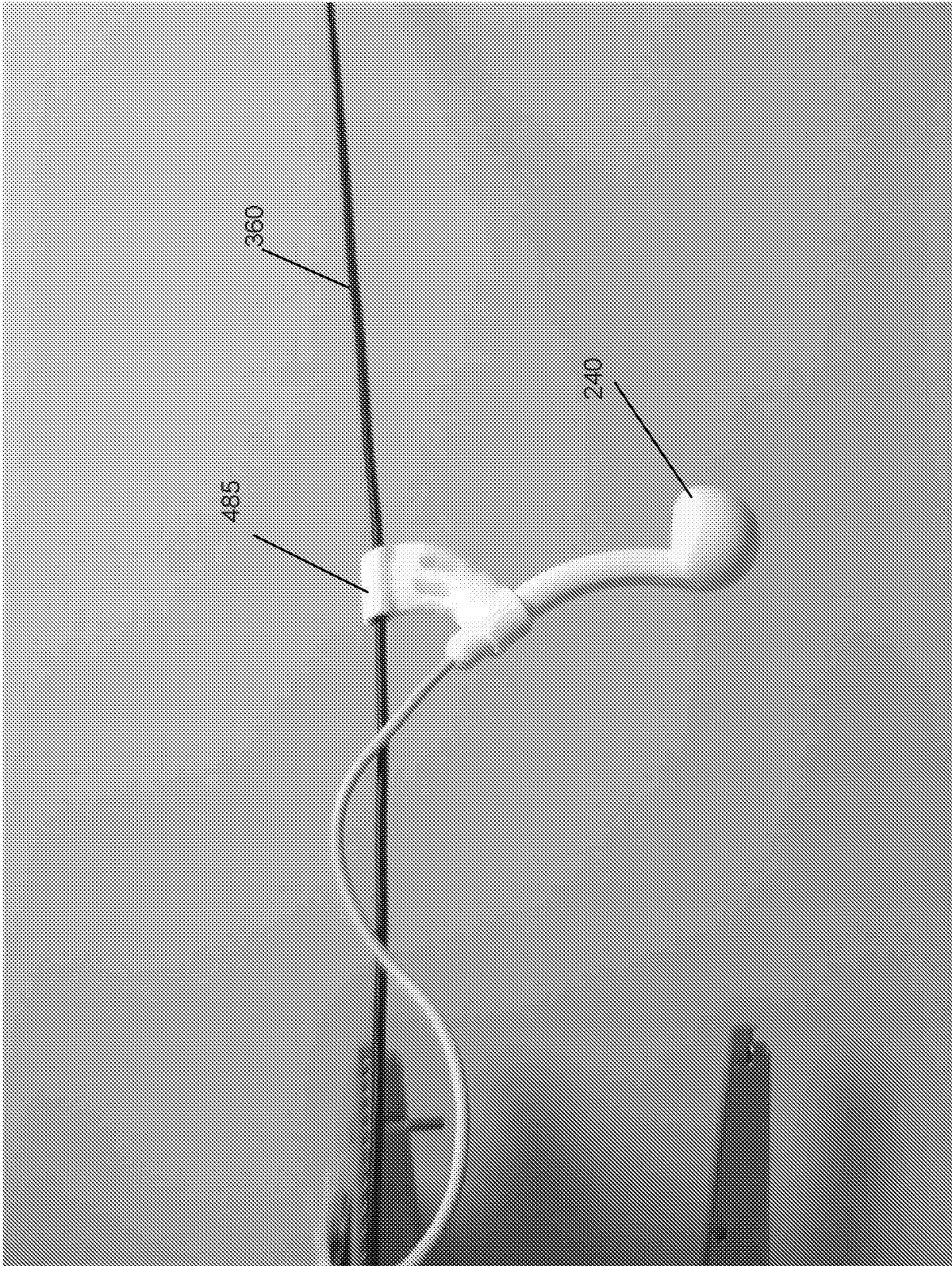

Fig. 4

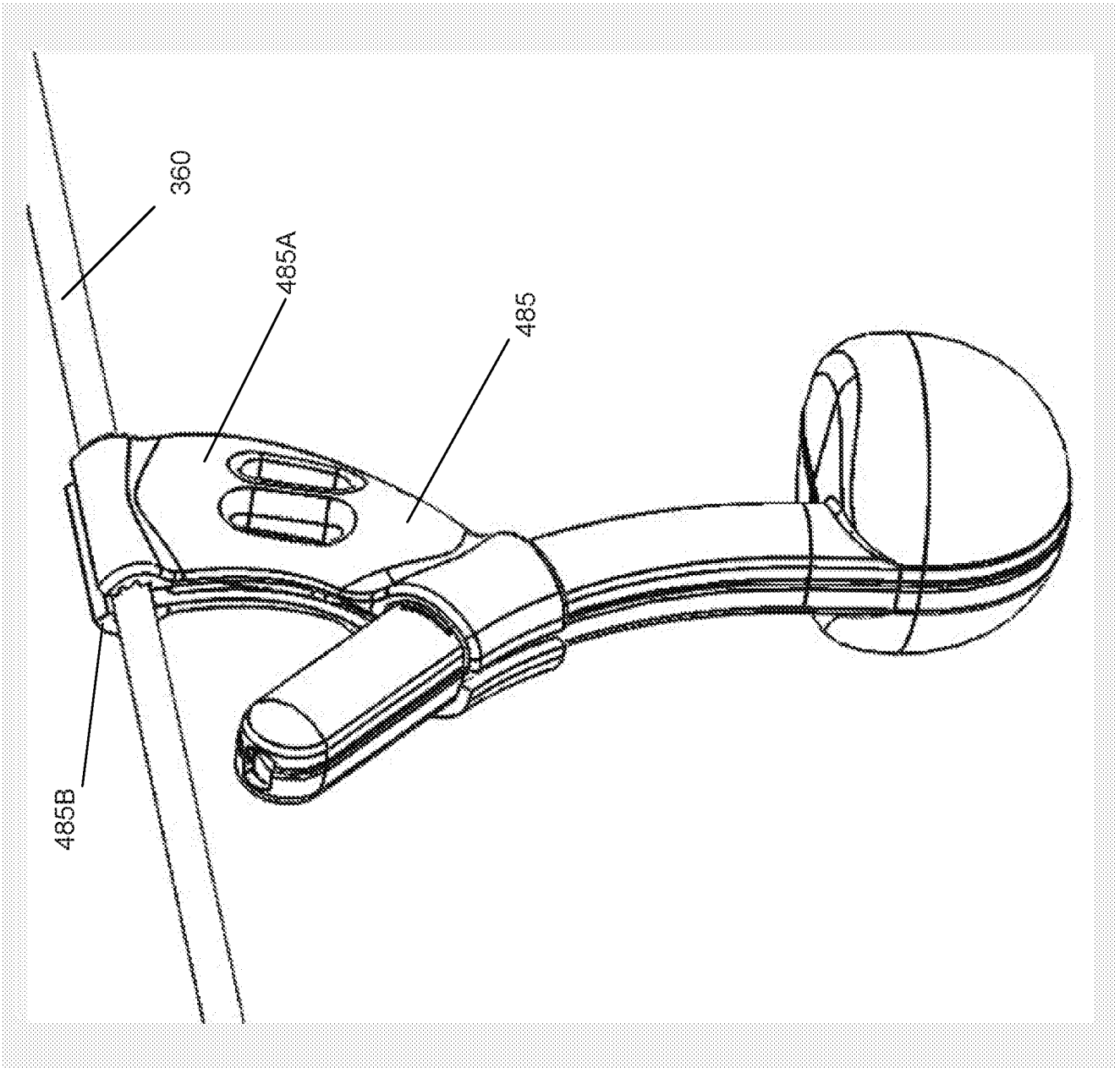

Fig. 5

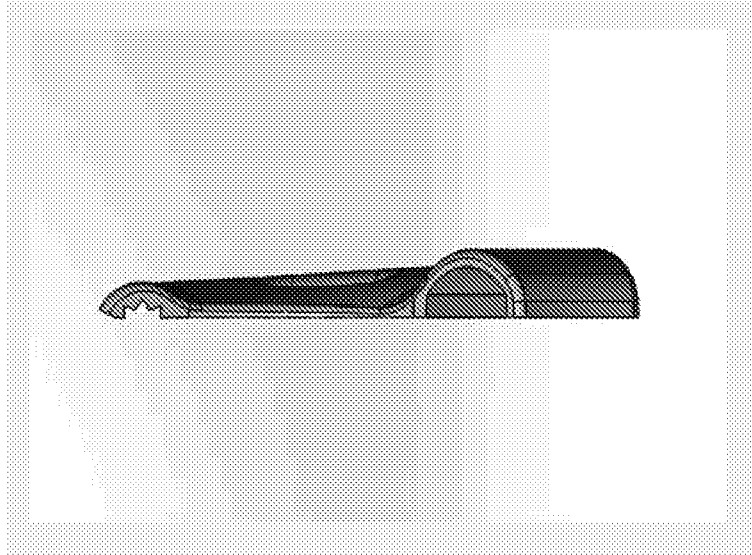

Fig. 6B

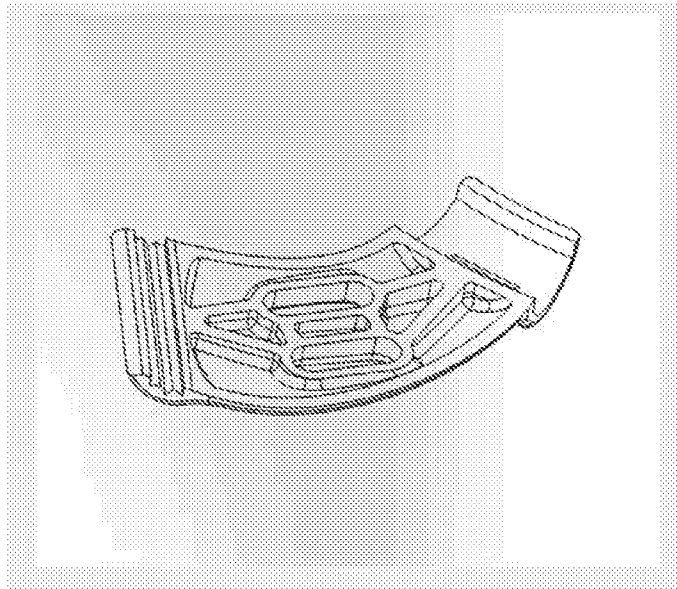

Fig. 6A

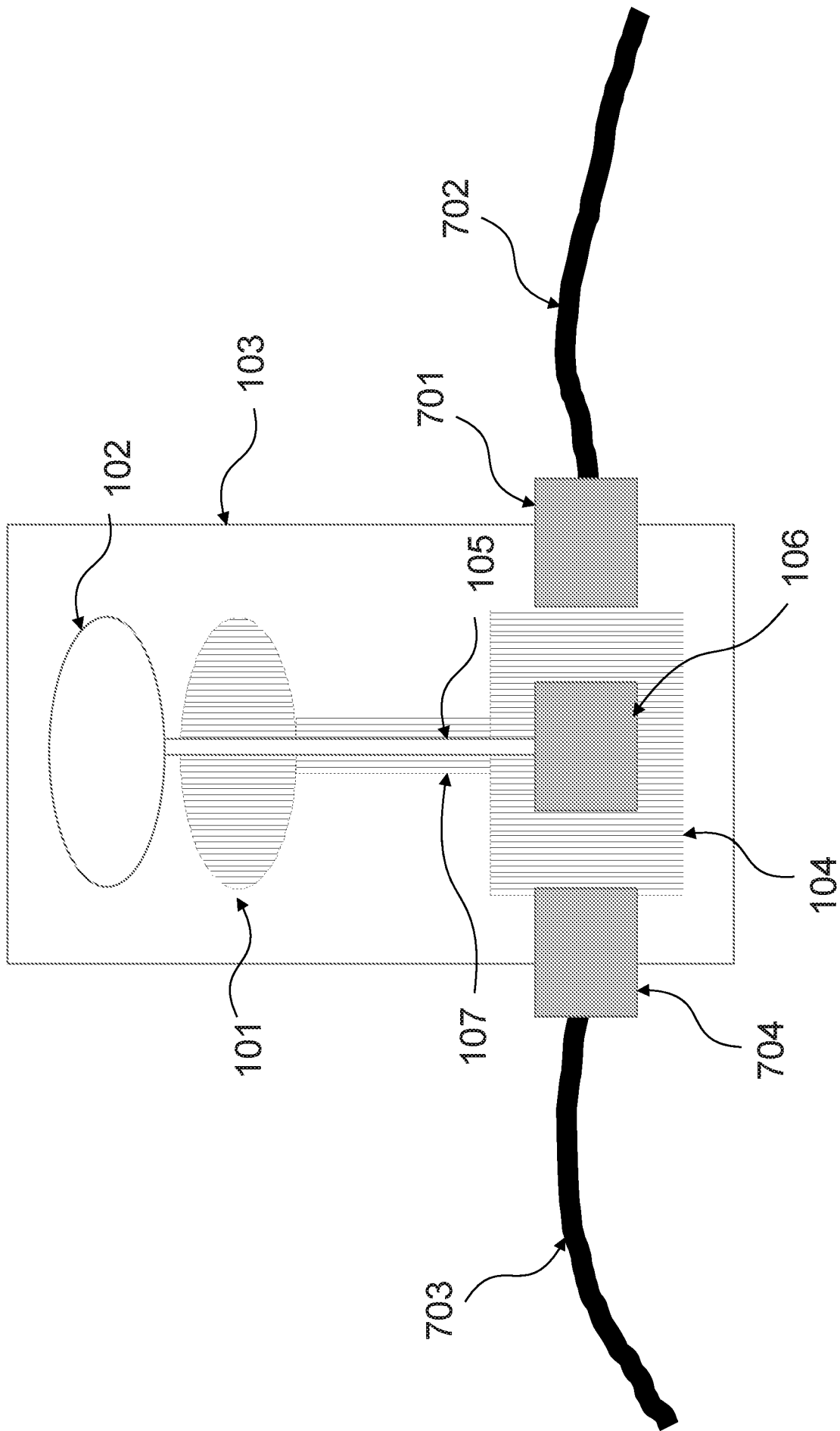

Fig. 7

INTERNATIONAL SEARCH REPORT

International application No
PCT/US2018/019365

A. CLASSIFICATION OF SUBJECT MATTER
 INV. H04L12/10 H04L12/40 G06F1/26 H04B3/44 H04L12/46
 H04W88/08 H04L12/26 H04L12/24
 ADD.
 According to International Patent Classification (IPC) or to both national classification and IPC

B. FIELDS SEARCHED
 Minimum documentation searched (classification system followed by classification symbols)
 H04L G06F H04B H04W
 Documentation searched other than minimum documentation to the extent that such documents are included in the fields searched

Electronic data base consulted during the international search (name of data base and, where practicable, search terms used)
 EPO-Internal, WPI Data

C. DOCUMENTS CONSIDERED TO BE RELEVANT

Category*	Citation of document, with indication, where appropriate, of the relevant passages	Relevant to claim No.
X A	US 2011/241425 A1 (HUNTER JR ROGER ALLAN [US] ET AL) 6 October 2011 (2011-10-06) figures 1,3 paragraphs [0032], [0033] paragraph [0035] -----	1-6, 8-17,19 7,18
X A	WO 2007/106795 A2 (CISCO TECH INC [US]; KARAM ROGER [US]; THOMAS ROBERT [US]) 20 September 2007 (2007-09-20) figures 1,2,3 page 12, line 3 - page 13, line 18 -----	1-6, 8-17,19 7,18
A	US 7 240 224 B1 (BIEDERMAN DANIEL C [US]) 3 July 2007 (2007-07-03) figure 2 column 5, line 4 - line 34 column 6, line 10 - line 48 ----- -/--	1-19

Further documents are listed in the continuation of Box C. See patent family annex.

* Special categories of cited documents :

"A" document defining the general state of the art which is not considered to be of particular relevance	"T" later document published after the international filing date or priority date and not in conflict with the application but cited to understand the principle or theory underlying the invention
"E" earlier application or patent but published on or after the international filing date	"X" document of particular relevance; the claimed invention cannot be considered novel or cannot be considered to involve an inventive step when the document is taken alone
"L" document which may throw doubts on priority claim(s) or which is cited to establish the publication date of another citation or other special reason (as specified)	"Y" document of particular relevance; the claimed invention cannot be considered to involve an inventive step when the document is combined with one or more other such documents, such combination being obvious to a person skilled in the art
"O" document referring to an oral disclosure, use, exhibition or other means	"&" document member of the same patent family
"P" document published prior to the international filing date but later than the priority date claimed	

Date of the actual completion of the international search 25 April 2018	Date of mailing of the international search report 07/05/2018
---	---

Name and mailing address of the ISA/ European Patent Office, P.B. 5818 Patentlaan 2 NL - 2280 HV Rijswijk Tel. (+31-70) 340-2040, Fax: (+31-70) 340-3016	Authorized officer Nold, Michael
--	--

INTERNATIONAL SEARCH REPORT

International application No
PCT/US2018/019365

C(Continuation). DOCUMENTS CONSIDERED TO BE RELEVANT		
Category*	Citation of document, with indication, where appropriate, of the relevant passages	Relevant to claim No.
A	WO 2016/184889 A1 (WEIDMÜLLER INTERFACE GMBH & CO KG [DE]) 24 November 2016 (2016-11-24) figure 1 page 2, line 37 - page 4, line 24 -----	1-19

INTERNATIONAL SEARCH REPORT

Information on patent family members

International application No PCT/US2018/019365

Patent document cited in search report	Publication date	Patent family member(s)	Publication date	
US 2011241425	A1	06-10-2011	CN 102823192 A	12-12-2012
			EP 2553868 A1	06-02-2013
			EP 2950480 A1	02-12-2015
			KR 20130055568 A	28-05-2013
			US 2011241425 A1	06-10-2011
			US 2015126251 A1	07-05-2015
			US 2016080159 A1	17-03-2016
			US 2017180142 A1	22-06-2017
			WO 2011123314 A1	06-10-2011

WO 2007106795	A2	20-09-2007	AT 523981 T	15-09-2011
			CN 101405675 A	08-04-2009
			EP 2005275 A2	24-12-2008
			US 2007220280 A1	20-09-2007
			US 2010049998 A1	25-02-2010
			WO 2007106795 A2	20-09-2007

US 7240224	B1	03-07-2007	NONE	

WO 2016184889	A1	24-11-2016	DE 102015107865 A1	24-11-2016
			EP 3298730 A1	28-03-2018
			WO 2016184889 A1	24-11-2016
