



US 20060166799A1

(19) **United States**

(12) **Patent Application Publication**
Boland et al.

(10) **Pub. No.: US 2006/0166799 A1**

(43) **Pub. Date: Jul. 27, 2006**

(54) **ABDOMINAL EXERCISE APPARATUS**

Publication Classification

(76) Inventors: **Kevin O. Boland**, Bethesda, MD (US);
Cornell S. Marschalko, McLean, VA
(US)

(51) **Int. Cl.**
A63B 21/008 (2006.01)
A63B 26/00 (2006.01)

(52) **U.S. Cl.** **482/140; 482/111**

Correspondence Address:

**BENESCH, FRIEDLANDER, COPLAN &
ARONOFF LLP**
ATTN: IP DEPARTMENT DOCKET CLERK
2300 BP TOWER
200 PUBLIC SQUARE
CLEVELAND, OH 44114 (US)

(57) **ABSTRACT**

A multidirectional abdominal exercise apparatus is disclosed herein. In one embodiment, the exercise apparatus includes a frame having an upright member, a bench or seat, and a pair of arm members connected to at least two pivoting members. The first pivoting member pivots in a first direction about a first axis substantially perpendicular to the floor. The second pivoting member is pivotally connected to the first pivoting member and pivots in a second direction about a second axis substantially perpendicular to the first direction and substantially perpendicular to a forward direction. Thus, a user can pivot the arm members in the first direction, the second direction, and both the first and second direction concurrently.

(21) Appl. No.: **11/259,375**

(22) Filed: **Oct. 26, 2005**

Related U.S. Application Data

(60) Provisional application No. 60/621,648, filed on Oct. 26, 2004.

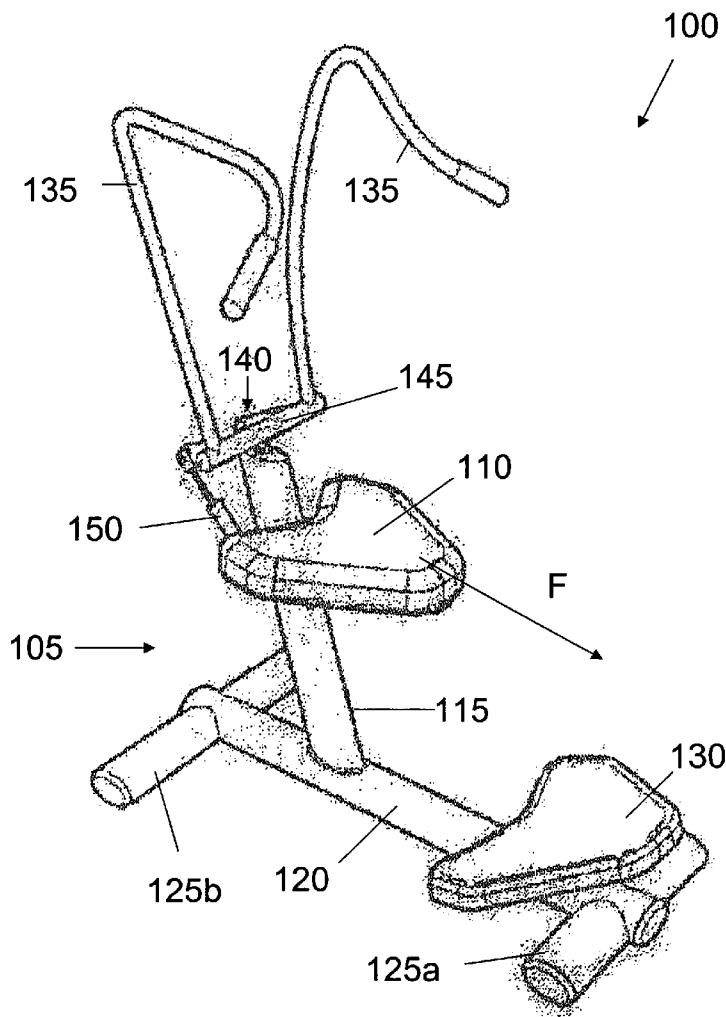

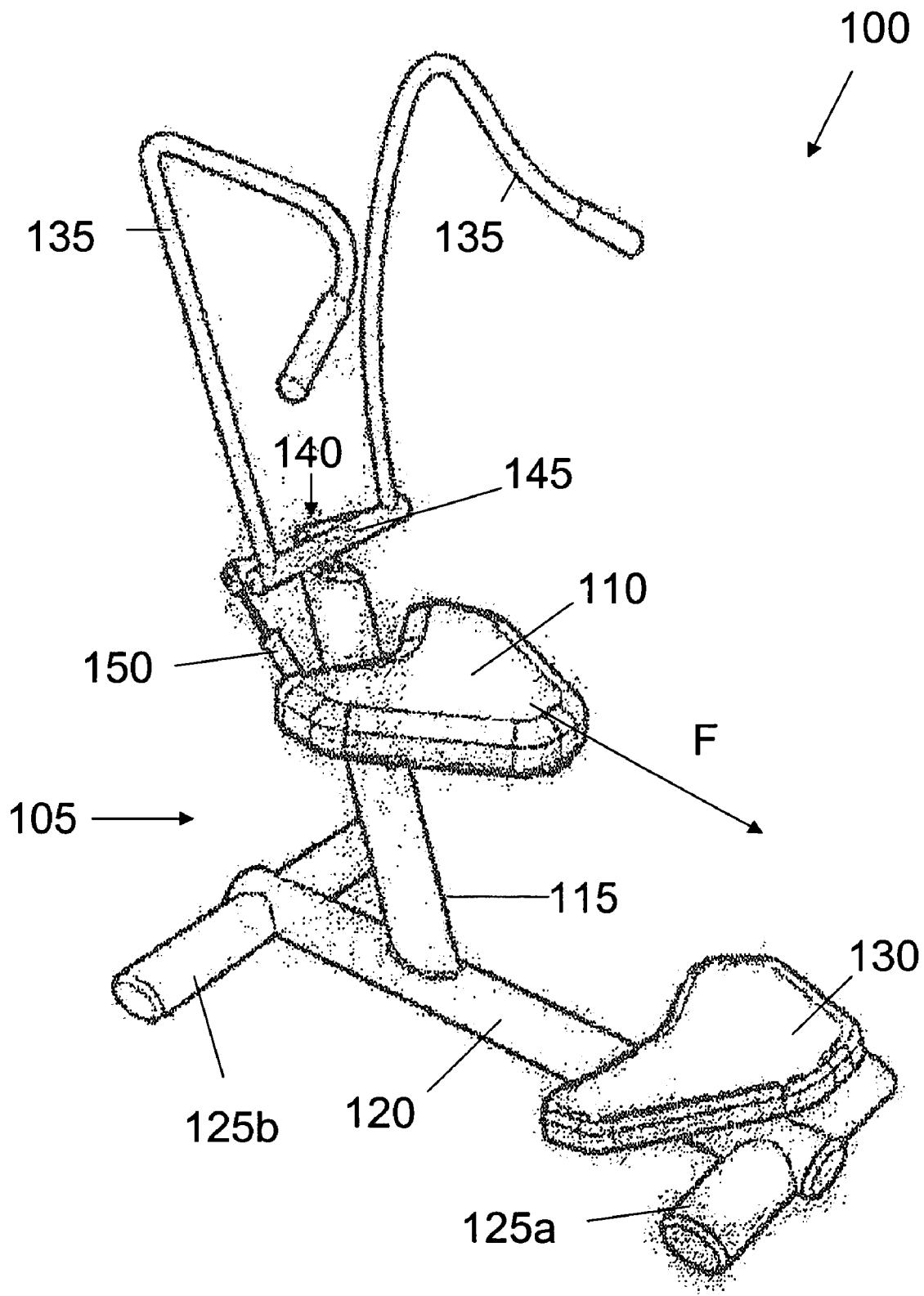

Figure 1

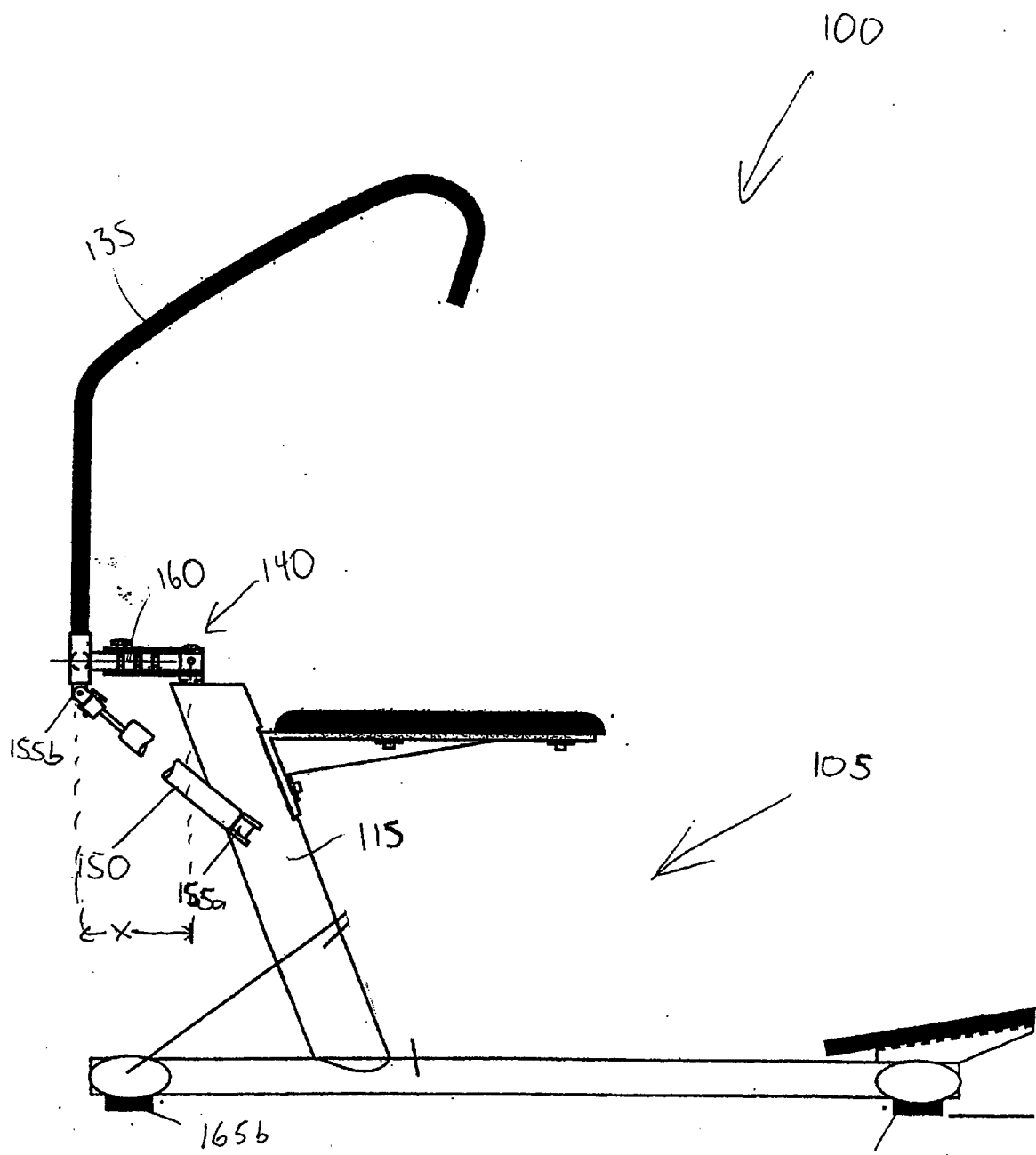

Figure 2

165a

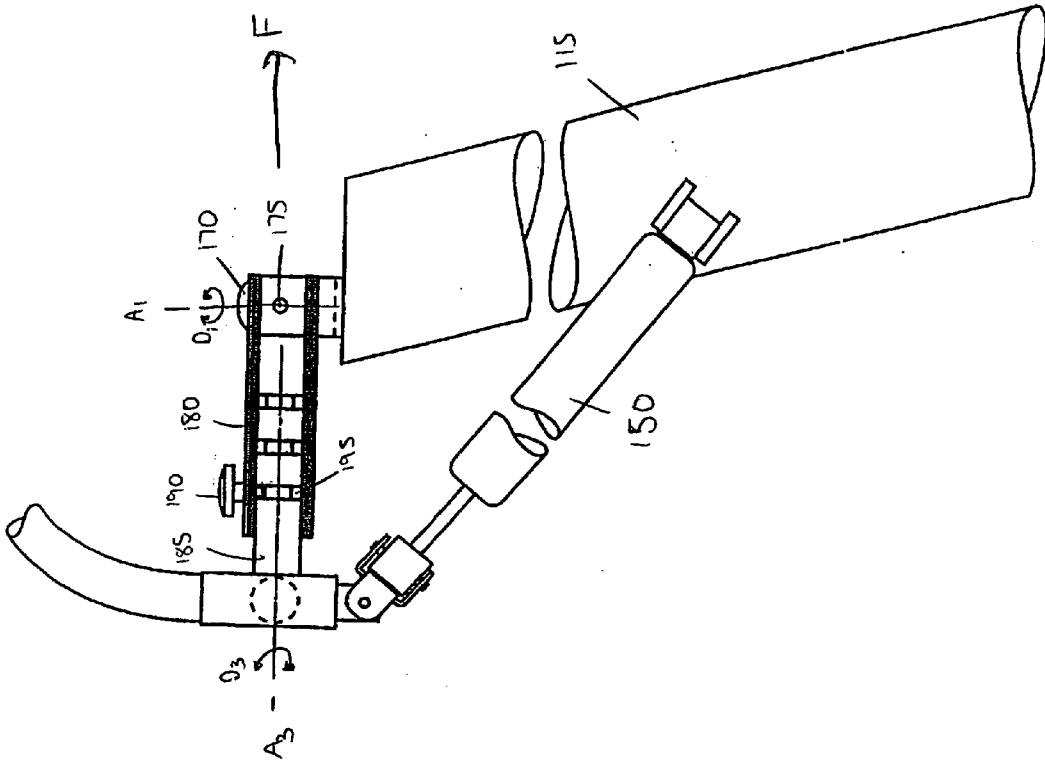

Fig. 3A

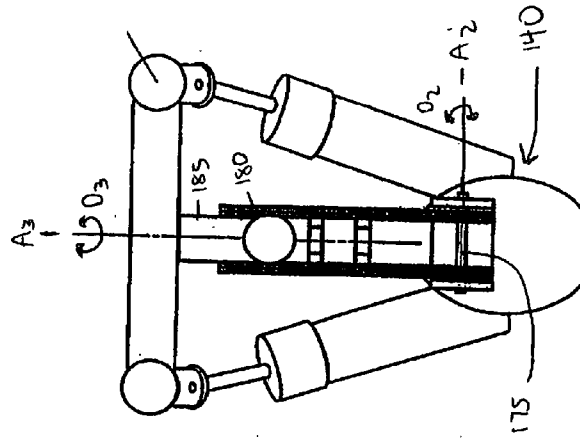

Figure 3b

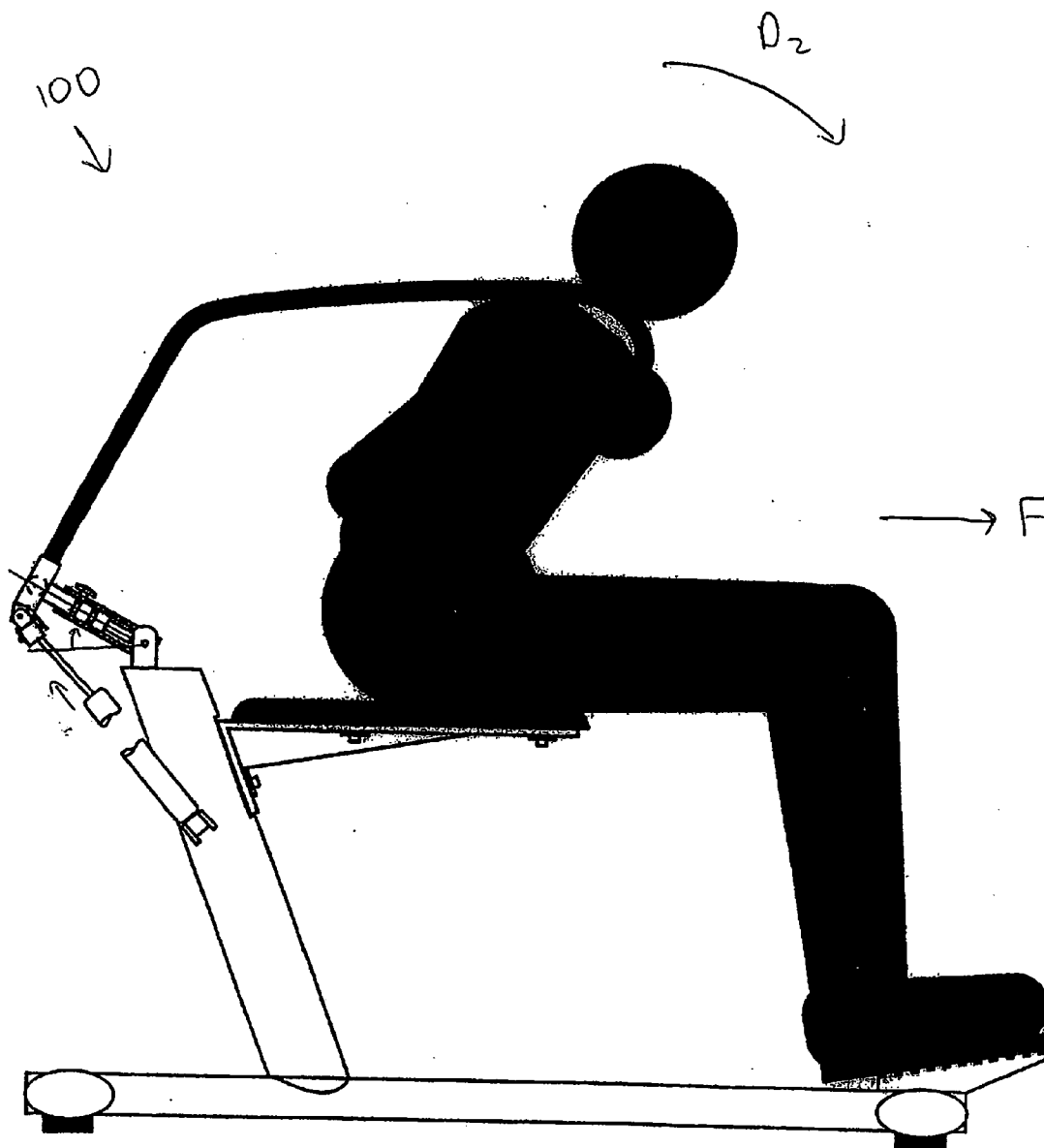

Figure 4A

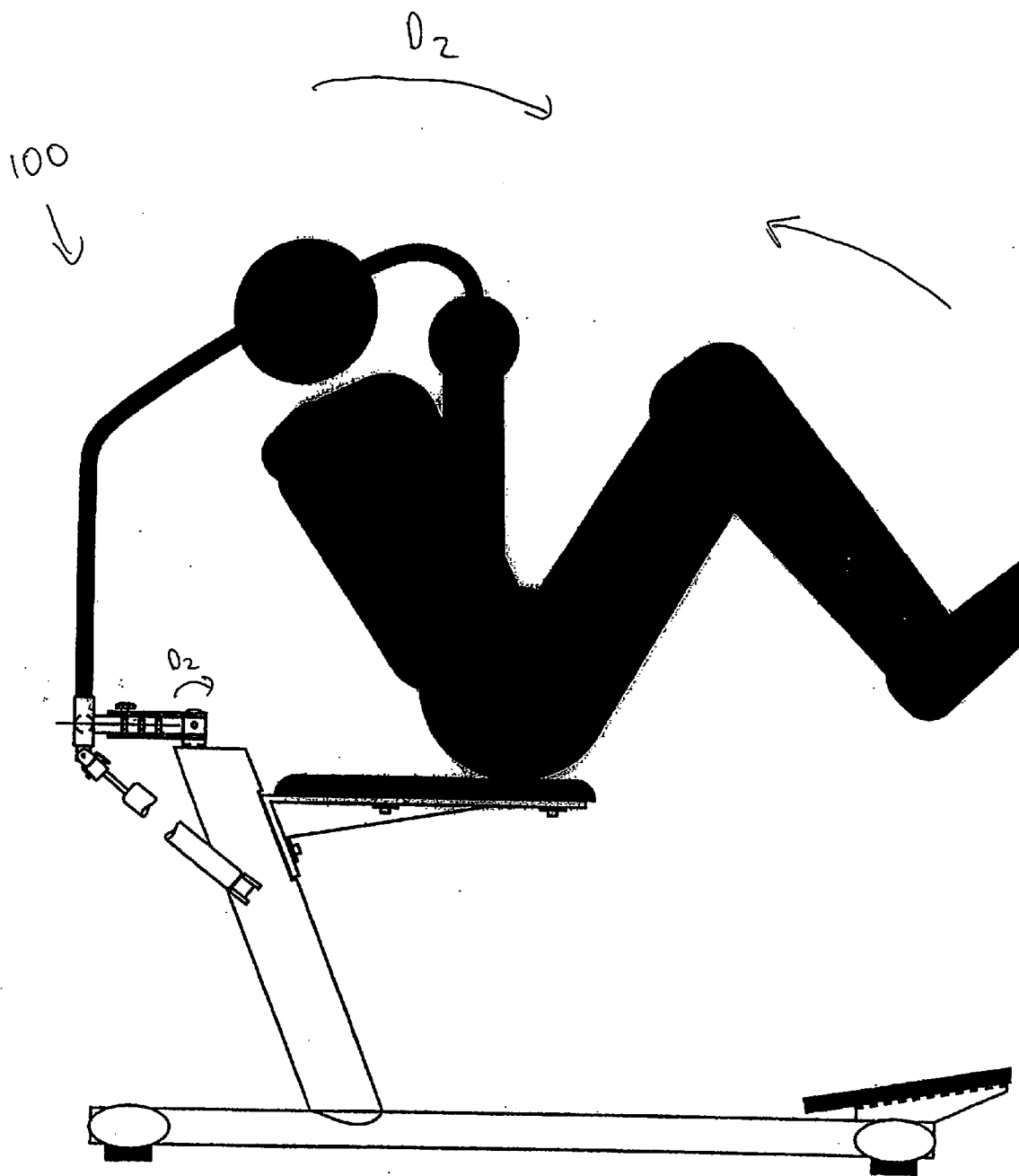

Figure 4B

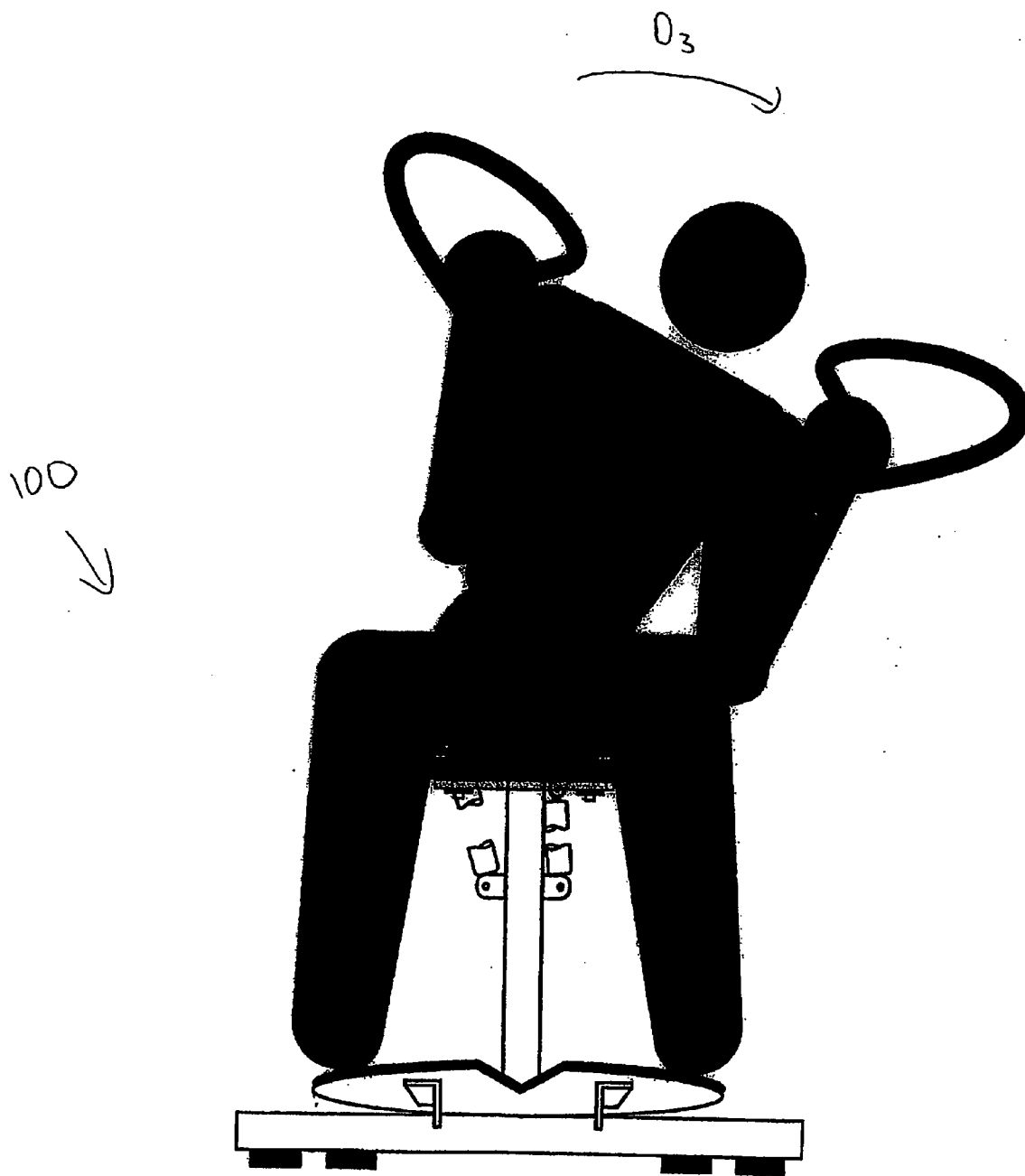

Figure 4C

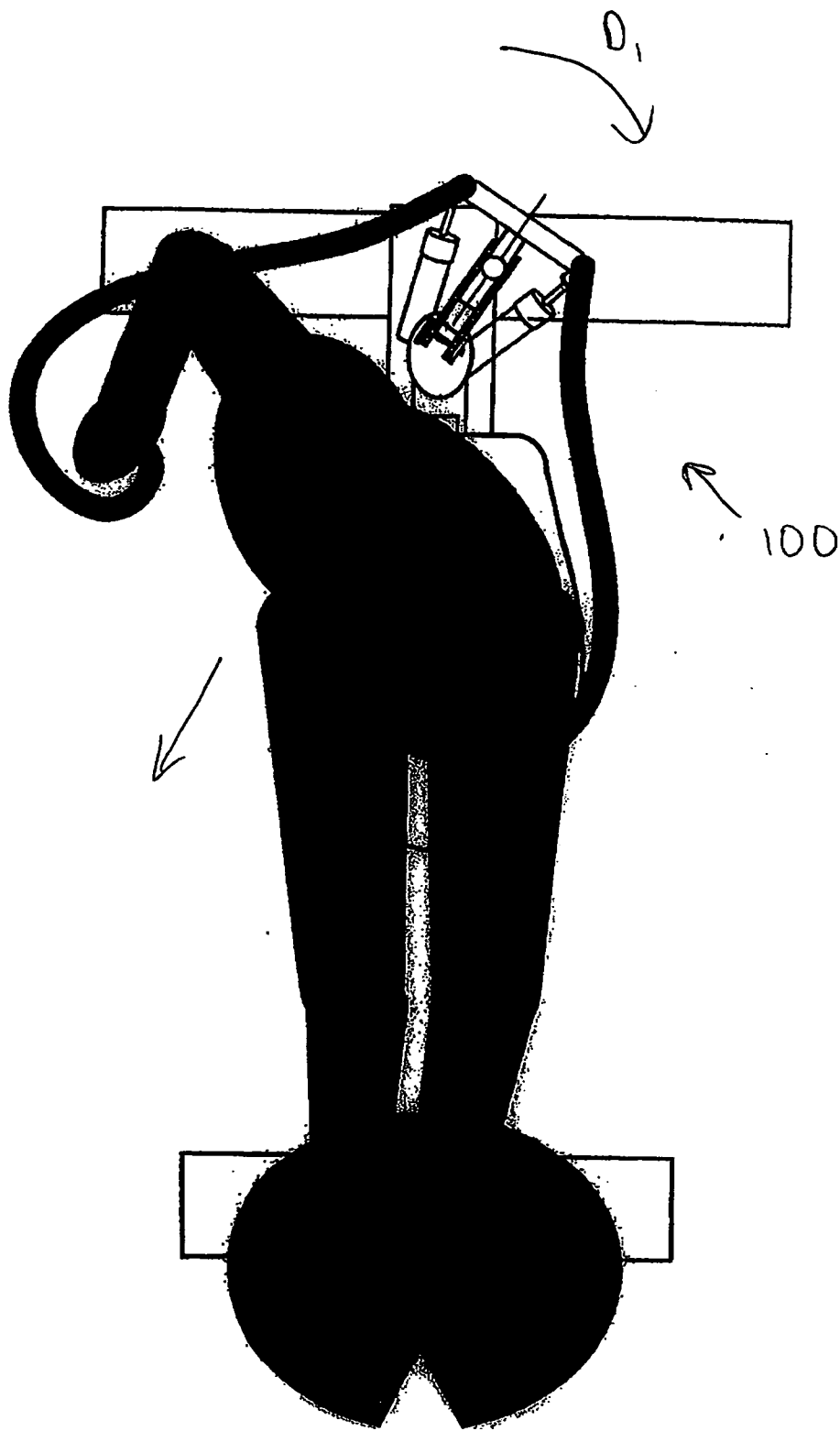

Figure 40

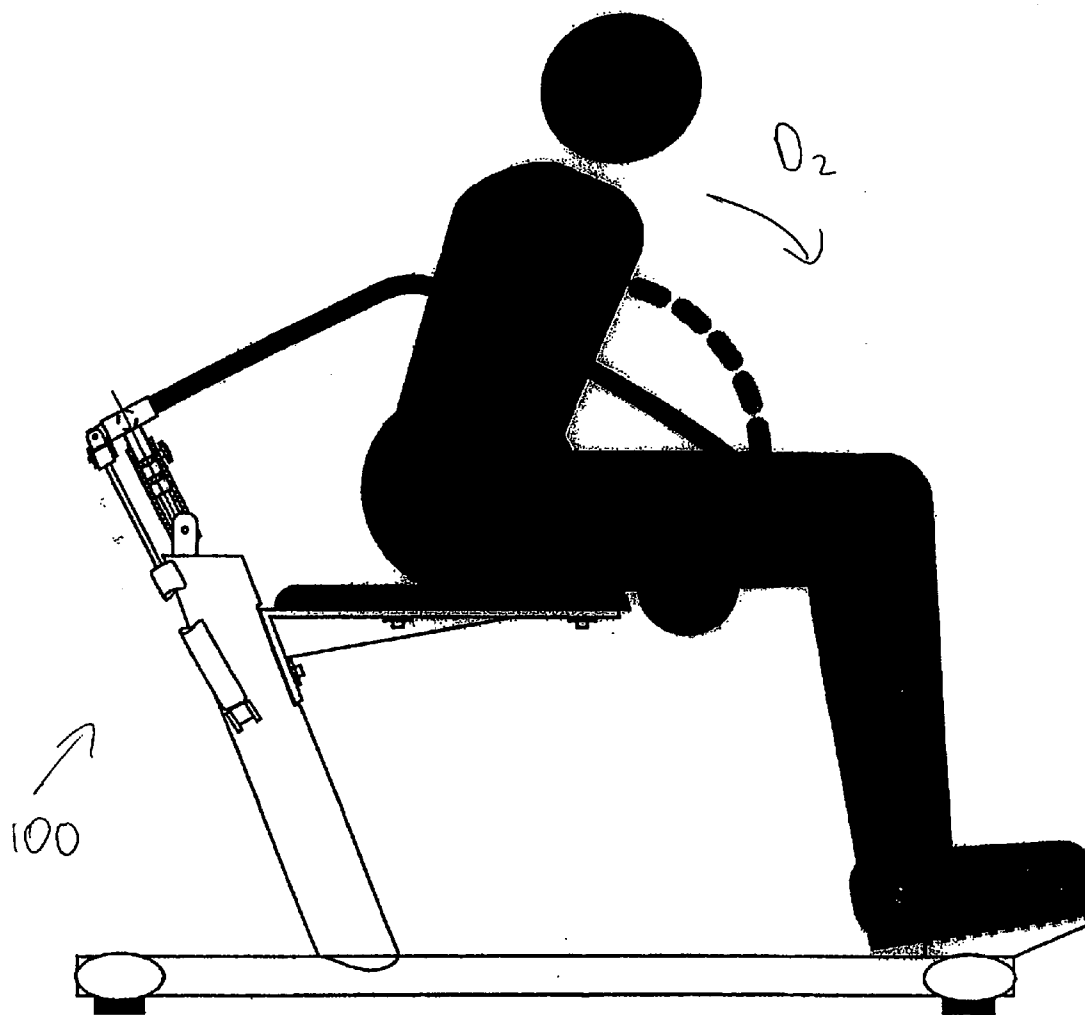

Figure 4E

ABDOMINAL EXERCISE APPARATUS

CROSS-REFERENCE TO RELATED APPLICATION

[0001] This application claims the benefit of priority of U.S. Provisional Application No. 60/621,648 filed on Oct. 26, 2004.

FIELD OF INVENTION

[0002] The present application relates to an exercise machine for exercising various muscle groups by employing a resistive force against a range of bodily movement. More particularly, the present application is a versatile exercise machine for exercising the main and lower abdominals, the internal and external obliques, the quadratus lumborum, and the triceps.

BACKGROUND

[0003] Many types of machines have been designed for exercising stomach, side, and lower back muscles. Some of these employ springs, bows, weights, elastic, and body weight as resistance and utilize stretching, pulling, twisting, bending, and tucking motions applied against this resistance to achieve the desired effect.

[0004] Generally, these machines are either unidirectional, enabling the user to work in only one plane of motion, or multi-directional, but with limited range of movement. Most often, adjustments are necessary to facilitate various modes of exercise, requiring the user to stop exercising in order to disconnect and reconnect the operative parts of the apparatus between modes.

BRIEF DESCRIPTION OF DRAWINGS

[0005] In the drawings and description that follows, like elements are identified with the same reference numerals. The drawings are not to scale and the proportion of certain elements may be exaggerated for the purpose of illustration.

[0006] **FIG. 1** is a simplified perspective view of one embodiment of an exercise machine **100**;

[0007] **FIG. 2** is a simplified side view of the exercise machine **100**;

[0008] **FIG. 3A** is a simplified side view of one embodiment of a multidirectional pivot assembly **140** of the exercise machine **100**;

[0009] **FIG. 3B** is a simplified top view of one embodiment of a multidirectional pivot assembly **140** of the exercise machine **100**; and

[0010] **FIG. 4A-E** are simplified views of a user performing various exercises on the exercise machine **100**.

DETAILED DESCRIPTION

[0011] This application describes an exercise machine for exercising various muscle groups by employing a resistive force against a range of bodily movement. **FIG. 1** illustrates a simplified perspective view of one embodiment of an exercise machine **100**. The exercise machine **100** is a multi-directional abdominal exercise apparatus. However, as described below, it may be employed for exercising abdomi-

nal, back, and arm muscles, including the main and lower abdominals, the internal and external obliques, the quadratus lumborum, and the triceps.

[0012] As shown in **FIG. 1**, the exercise machine **100** includes a frame assembly, or support assembly, **105** configured to support a user in at least a sitting position. The frame assembly **105** includes at least a bench or a seat **110** and an upright member **115**. In the illustrated embodiment, the upright member **115** is an angled post. In alternative embodiments (not shown), the frame assembly may employ a vertical post, an A-frame, a plurality of legs, or any other appropriate member.

[0013] The seat **100** defines a forward direction F. In other words, in the illustrated embodiment, the seat **100** is configured to orient a user towards the forward direction F under normal operation of the exercise machine. As will be described in more detail below, most of the exercises performed on the exercise machine **100** require a user to sit in the seat **100** facing the forward direction F. In the illustrated embodiment, the seat **110** is a contoured seat mounted parallel to a floor surface. In alternative embodiments (not shown), the frame assembly may employ an oblong bench or any other known structure for supporting a user. In other alternative embodiments (not shown), the seat may be mounted to the upright member at an angle, or the angle of the seat may be adjustable to accommodate different preferences of a user or to allow a user to perform additional exercises. In yet another alternative embodiment (not shown), the height of the seat may be adjustable to accommodate users of different sizes.

[0014] With continued reference to **FIG. 1**, the frame assembly **105** further includes an elongated body member **120** and front and rear members **125_{a,b}** configured to rest upon a floor surface. The frame assembly **105** also includes an optional foot support member or members, such as a foot plate **130**. In one embodiment, the frame assembly **105** is constructed of metal tubing, such as 4-inch elliptical tubing. In other embodiments, the frame assembly may be constructed of a polymeric material or other suitable material.

[0015] The exercise machine **100** further includes a pair of arm members **135** connected to a pivot assembly **140**, such that the arm members **135** may be engaged by a user and pivoted in a first direction, a second direction, and the first and second directions concurrently, as will be described in more detail below. In the illustrated embodiment, the arm members **135** include ergonomically designed handlebars to provide a comfortable grip for a user. The arm members **135** are connected to each other via a rigid connection **145**, such that both arm members must be moved together. In an alternative embodiment (not shown) the arm members may be connected to separate pivots so that each arm member may be moved independently of the other. In another alternative embodiment (not shown), the arm members may part of a unitary component.

[0016] The exercise machine **100** further includes at least one resistance mechanism, as will be further described below. In the illustrated embodiment, the exercise machine **100** employs a pair of piston and cylinder assemblies **150**. The piston and cylinder assemblies may be adjustable or non-adjustable. In an alternative embodiment (not shown), the exercise machine employs a single piston and cylinder assembly. In other alternative embodiments (not shown), the

exercise machine may employ elastic bands, springs, weights, or any other known resistance mechanisms.

[0017] FIG. 2 illustrates a simplified side view of the exercise machine 100. As shown in FIG. 2, the piston and cylinder assemblies 150 are disposed between the frame assembly 105 and the arm members 135. In the illustrated embodiment, the piston and cylinder assemblies 150 are pivotally connected to the upright member 115 via pivoting connections 155a,b. The piston and cylinder assemblies 150 would thus provide resistance in any direction the arms 135 are moved. In an alternative embodiment, the piston and cylinder assemblies 150 may be connected via ball and joint connections. In other alternative embodiments (not shown), the exercise machine may employ a resistance mechanism that is connected to a seat or another member of a frame assembly. In another alternative embodiment (not shown), the resistance mechanism may be directly connected to the pivot assembly 140.

[0018] The exercise machine 100 also employs a resistance adjustment mechanism 160, as will be described in more detail below. For example, in the illustrated embodiment, the resistance mechanism 160 is configured to adjust a distance X measured from the pivot assembly 140 to the pivoting connection 155b between the piston and cylinder assembly 150 and the arm members 135. As this distance X is increased, the user will have to move the piston and cylinder assembly 150 through a greater range of motion and thus feel more resistance. In other embodiments (not shown) the resistance may be adjusted by adjusting the internal resistance of a piston and cylinder assembly, or by adding or subtracting elastic bands, springs, weights, or other resistance members.

[0019] With continued reference to FIG. 2, the frame assembly 105 includes front and rear floor guides 165a,b. The floor guides 165a,b are constructed of a material softer than metal and having a low coefficient of friction so that the exercise machine 100 may be easily moved across a floor surface and the exercise machine will not damage a floor surface. Exemplary materials include nylon or other polymeric materials.

[0020] FIG. 3A illustrates a side view of the pivot assembly 140 of the exercise machine 100 and FIG. 3B illustrates a top view of the pivot assembly 140. The pivot assembly 140 may be a multi-directional, or omni-directional pivot assembly that has the ability to move about an x-axis, a y-axis, and a z-axis. A multi-directional pivot assembly has at least two pivoting members.

[0021] In the illustrated embodiment, the pivot assembly 140 includes a first pivoting member, a second pivoting member, and a third pivoting member. For example, and as shown in

[0022] FIG. 3A, the first pivoting member includes an upright shaft 170 having a U-shaped component. The upright shaft 170 is disposed in an aperture (not shown) in the upright member 115 of the frame assembly 105. The upright shaft 170 has an axis A_1 that is substantially perpendicular to the floor surface. The upright shaft 170 is configured to rotate within the aperture about its axis A_1 in a first direction D_1 .

[0023] As shown in FIG. 3B, the second pivoting member of the pivot assembly 140 includes, for example, a pin 175

disposed in the U-shaped portion of the upright shaft 170 and a sleeve 180 configured to pivot about the pin 175. The pin 175 has an axis A_2 that is substantially perpendicular to both the first axis A_1 and the forward direction F. The sleeve 180 is configured to pivot about the axis A_2 of the pin 175 in a second direction D_2 .

[0024] As shown in FIGS. 3A and 3B, the third pivoting member of the pivot assembly 140 includes, for example, an elongated shaft 185 that is telescopically received within the sleeve 180. The elongated shaft 185 has an axis A_3 . When the exercise machine 100 is in a rest position, the axis A_3 of the elongated shaft 185 is substantially parallel to the forward direction F. The elongated shaft 185 is configured to rotate about its axis A_3 within the sleeve 180 in a third direction D_3 .

[0025] Thus, the omni-directional pivot assembly 140 allows a user to engage the arm members 135 and move the arms in a forward direction F, twist the arms in a sideways direction, or move the arms in a forward direction while simultaneously twisting the arms in a sideways and/or up-and-down direction. When the arm members are so moved, the piston and cylinder assemblies 150 provide resistance in all directions.

[0026] In the illustrated embodiment, the sleeve 180 is pivotally connected to the upright shaft 170 and the elongated shaft 185 is rigidly connected to the arm members 135. In an alternative embodiment (not shown), the sleeve 180 is rigidly connected to the arm members 135 and the elongated shaft 185 is pivotally connected to the upright shaft 170. In another alternative embodiment (not shown), the sleeve 180 is rigidly connected to the upright shaft 170 and the elongated shaft 185 is pivotally connected to the arm members 135. In yet another alternative embodiment, the sleeve 180 is pivotally connected to the arm members 135 and the elongated shaft 185 is rigidly connected to the upright shaft 170.

[0027] In an alternative embodiment (not shown), the exercise machine employs a pivot member having only the first and second pivoting members, such as an upright shaft and a pin. In this embodiment, the user could manipulate the arms to move them in a forward direction and a sideways direction.

[0028] In another alternative embodiment (not shown), the exercise machine employs separate, distinct pivots rather than a single pivot having multiple pivoting members.

[0029] FIGS. 3A and 3B further illustrate the resistance adjustment mechanism 160. In the illustrated embodiment, the resistance adjustment mechanism 160 includes the sleeve 180 of the pivot assembly 140 and the elongated shaft 185. As described above, the elongated shaft 185 is telescopically received within the sleeve 180, such that it can be moved within the sleeve 180 in a forward direction F or in a backward direction. Additionally, the rod 185 is rotatable in the third direction D_3 as described above.

[0030] The resistance adjustment mechanism 160 further includes a locking mechanism 190. The locking mechanism may be a pin, a plunger, or other appropriate locking device. The locking mechanism 190 is inserted into an aperture (not shown) in the sleeve 180 and is received in one of a plurality of spaced apart grooves 195 in the elongated shaft 185. Thus, the elongated shaft 185 can be moved to a desired

position within the sleeve **180** and locked into position by the locking member **190**. This changes the distance X between the pivot assembly **140** and the pivoting connection **155b** between the piston and cylinder assembly **150** and the arm members **135**, thereby adjusting the resistance provided by the piston and cylinder assembly **150**.

[0031] In an alternate embodiment (not shown), in which the exercise machine only employs two pivoting members, an elongated member having a plurality of spaced apart apertures is inserted into the sleeve **180** such that it can be slidably moved within the sleeve **180** in a forward or backward direction. A locking mechanism can be inserted in one of the plurality of apertures to lock the elongated portion in a preferred position. In this embodiment, the elongated member does not rotate within the sleeve **180**.

[0032] FIGS. 4A-E illustrate several exemplary modes of operation of the exercise machine **100**. For example, FIG. 4A illustrates a simplified side view of a user performing a forward crunch. A user performs this exercise by sitting on the seat **110** with his feet resting on the foot plate **130** and facing a forward direction F. The user then pulls forward and downward on the arm members **135** while bending his body in the same direction, causing the sleeve **180** to pivot about the pin **175** in the second direction D_2 . This mode of operation exercises the upper abdominal muscles.

[0033] FIG. 4B is a simplified side view of a user performing a reverse crunch on the exercise machine **100**. A user performs this exercise by tilting back in the seat **110** and raising his legs towards his torso while simultaneously pulling the arm members **135** forward and downward, causing the sleeve **180** to pivot about the pin **175** in the second direction D_2 . This mode of operation exercises the lower abdominal muscles and thigh muscles.

[0034] FIG. 4C is a simplified front view of a user performing a side-to-side crunch on the exercise machine **100**. A user performs this exercise by sitting on the seat **110** with his feet resting on the foot plate **130** and facing a forward direction F. The user then pulls the arm members **135** sideways and downwards while simultaneously bending the torso in the same direction, causing the elongated shaft **185** to rotate within the sleeve **180** in the third direction D_3 . This mode of operation exercises the lower back (quadratus lumborum) muscles.

[0035] FIG. 4D is a simplified top view of a user performing an oblique abdominal crunch on the exercise machine **100**. A user performs this exercise by sitting on the seat **110** with his feet resting on the foot plate **130** and facing a forward direction F. The user then pulls the arm members **135** forward and sideways while simultaneously twisting the torso in the same direction, causing the upright shaft **170** to pivot in the first direction D_1 , while the sleeve **180** simultaneously pivots about the pin **175** in the second direction D_2 , and the elongated shaft **185** rotates within the sleeve **180** in the third direction D_3 . This mode of operation exercises the inner and outer oblique muscles.

[0036] FIG. 4E is a side view of a user performing a tricep extension on the exercise machine **100**. A user performs this exercise by sitting on the seat **110** with his feet resting on the foot plate **130** and facing a forward direction F. The user pulls the arm members in a forward and downward direction while keeping his torso stationary, causing the sleeve **180** to

pivot about the pin **175** in the second direction D_2 . This mode of operation exercises the tricep muscles. In an alternative modes of operation, the user may perform this exercise while standing and facing a forward direction F, while standing and facing the direction opposite the forward direction F, or while kneeling on the seat and facing the direction opposite the forward direction F.

[0037] A user can perform all of the exercises illustrated in FIGS. 4A-E without making adjusting the exercise machine **100**. Thus, a user may proceed from one mode to the next without delay, increasing the time effectiveness of the workout.

[0038] To the extent that the term “includes” or “including” is used in the specification or the claims, it is intended to be inclusive in a manner similar to the term “comprising” as that term is interpreted when employed as a transitional word in a claim. Furthermore, to the extent that the term “or” is employed (e.g., A or B) it is intended to mean “A or B or both”. When the applicants intend to indicate “only A or B but not both” then the term “only A or B but not both” will be employed. Thus, use of the term “or” herein is the inclusive, and not the exclusive use. See, Bryan A. Garner, A Dictionary of Modern Legal Usage 624 (2d. Ed. 1995). Also, to the extent that the terms “in” or “into” are used in the specification or the claims, it is intended to additionally mean “on” or “onto.” Furthermore, to the extent the term “connect” is used in the specification or claims, it is intended to mean not only “directly connected to,” but also “indirectly connected to” such as connected through another component or components.

[0039] While the present application has been illustrated by the description of embodiments thereof, and while the embodiments have been described in some detail, it is not the intention of the applicants to restrict or in any way limit the scope of the appended claims to such detail. Additional advantages and modifications will readily appear to those skilled in the art. Therefore, the application, in its broader aspects, is not limited to the specific details, the representative apparatus, on the illustrative embodiments shown and described. Accordingly, departures may be made from such details without departing from the spirit or scope of the applicant’s general inventive concept.

1. A multidirectional abdominal exercise apparatus comprising:

a frame configured to rest upon a floor surface, the frame including an upright member;

a bench connected to the upright member of the frame, the bench defining a forward direction;

at least two pivoting members, including a first pivoting member and a second pivoting member, wherein

the first pivoting member is pivotally connected to one of the bench and the upright member, the first pivoting member being configured to pivot in a first direction about a first axis that is substantially perpendicular to the floor surface and

the second pivoting member is pivotally connected to the first pivoting member, the second pivoting member being configured to pivot in a second direction about a second axis that is substantially parallel to

the floor surface, substantially perpendicular to the first direction, and substantially perpendicular to the forward direction; and

a pair of arm members connected to the second pivoting member and configured to be engaged by a user, wherein the user can pivot the arm members in the first direction, the second direction, and both the first and second direction concurrently.

2. The apparatus of claim 1, further comprising at least one resistance member that is connected to the upright member of the frame and the pair of arm members.

3. The apparatus of claim 2, wherein the at least one resistance member includes at least one piston and cylinder assembly.

4. The apparatus of claim 1, wherein the second pivoting member includes a sleeve and the arm members are attached to a slideable member having spaced apart apertures configured to receive a locking mechanism, wherein the slideable member is configured to be moved to a plurality of different positions within the sleeve and locked into place by the locking mechanism.

5. The apparatus of claim 1, further comprising a third pivoting member that is pivotally connected to the arm members and is configured to pivot in a third direction about a third axis that is parallel to the forward direction.

6. The apparatus of claim 5, wherein the second pivoting member includes a sleeve and the third pivoting member has a plurality of spaced apart grooves configured to receive a locking mechanism, wherein the third pivoting member is inserted into the sleeve and is configured to be rotated within the sleeve and slideably moved to a plurality of different positions within the sleeve and locked into place by the locking mechanism.

7. The apparatus of claim 1, further comprising at least one foot support member connected to the forward member of the frame.

8. The apparatus of claim 1, wherein the bench is configured to be connected to the upright member of the frame at a plurality of different heights, so as to accommodate users of different heights.

9. An abdominal exercise apparatus comprising:

a support assembly configured to support a user in at least a sitting position;

a pair of arm members connected to the support assembly via an omni-directional pivot such that the pair of arm members are pivotal in a direction substantially perpendicular to the ground and in a transverse direction; and

a pair of resistance members having one end connected to the support assembly and one end connected to a respective arm member.

10. The apparatus of claim 9, wherein the omni-directional pivot includes at least two pivoting members, wherein a first pivoting member is configured to pivot in a direction substantially perpendicular to the ground and a second pivot member is configured to pivot in a transverse direction.

11. The apparatus of claim 9, wherein the omni-directional pivot includes at least three pivoting members, wherein a first pivoting member is configured to pivot in a first direction that is substantially perpendicular to the

ground, a second pivot member is configured to pivot in a second direction that is transverse to the first direction, and third pivoting member is configured to pivot in a third direction that is transverse to both the first and second direction.

12. The apparatus of claim 9, wherein the support assembly includes a frame and a seat.

13. The apparatus of claim 9, wherein the pair of resistance members includes a pair of piston and cylinder assemblies.

14. The apparatus of claim 9, wherein the pair of resistance members includes a pair of elastic bands.

15. The apparatus of claim 9, further comprising a resistance adjustment mechanism.

16. The apparatus of claim 15, wherein the resistance adjustment mechanism includes:

a sleeve portion;

an elongated member slideably inserted into the sleeve portion, the elongated member having a plurality of spaced apart grooves; and

a locking member adapted to be received in a selected groove of the elongated member to lock the elongated member into a selected position.

17. The apparatus of claim 16, wherein the sleeve portion is connected to the omni-directional pivot and the elongated portion is connected to the pair of arm members.

18. The apparatus of claim 16, wherein the sleeve portion is connected to the pair of arm members and the elongated portion is connected to the omni-directional pivot.

19. A multidirectional exercise machine comprising:

a frame assembly configured to rest on a floor surface; and

a pair of arms connected to the frame assembly via at least two pivotal connections, the at least two pivotal connections including at least a first pivotal connection configured to allow the arms to pivot in a first direction substantially perpendicular to the floor surface, and a second pivotal connection configured to allow the arms to pivot in a second direction substantially perpendicular to the first direction.

20. The multidirectional exercise machine of claim 19, wherein the pair of arms are connected to the frame assembly via a third pivotal connection configured to allow the arms to pivot in a third direction that is substantially perpendicular to both the first and second direction.

21. The multidirectional exercise machine of claim 19, wherein the frame assembly includes a bench defining a forward direction.

22. The multidirectional exercise machine of claim 20, wherein the second direction is substantially perpendicular to the forward direction.

23. The multidirectional exercise machine of claim 19, further comprising at least one resistance providing member provided between the frame assembly and the pair of arm members.

24. The multidirectional exercise machine of claim 23, further comprising means for adjusting the resistance providing member.