

(12) UK Patent Application (19) GB (11) 2 146 504 A

(43) Application published 17 Apr 1985

(21) Application No 8324228

(22) Date of filing 9 Sep 1983

(71) Applicant
Electronic Automation Limited (United Kingdom),
202 High Street, Hull, North Humberside

(72) Inventor
Clive Loughlin

(74) Agent and/or Address for Service
H. L. Cottrell & Co.,
22 Whitefriargate, Hull, N Humberside

(51) INT CL⁴
H04N 3/15

(52) Domestic classification
H4F CC D27A2 D27T2 D30K D83B

(56) Documents cited
GB A 2090100 GB 1225071
GB 1405699
Electronic design, No 6, March 15 1976, W. F. Kosonocky and D. J. Sauer, "Consider CCDS for a wide range of uses", pages 70-78, especially page 70, lines 5-6.
IEEE Transactions on Electron Devices, Vol ED-23, No 2 February 1976, C. W. Sequin et al, "All Solid State Camera for the 525-Line TV Format", Pages 183-189
IEEE Transactions on Electron Devices, Vol ED-23, No 2 February 1976, D. M. Brown et al, "Transparent Metal Oxide CID Imager", pages 196-200.
Wireless World March 1975, T. Williams "Charge-Coupled Devices 4 Imaging Applications", pages 133-138.

(58) Field of search
H4F

(54) Image recording device

(57) A visual image recording device comprises a solid state dynamic shift register 5 having the solid state elements thereof exposed so that light may be focussed thereon, and an adjustable lens 13 for focussing light on the said exposed elements. The recording device may be contained in a cuboid of some 15 mm side.

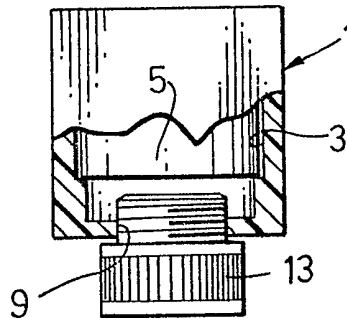

FIG.1

GB 2 146 504 A

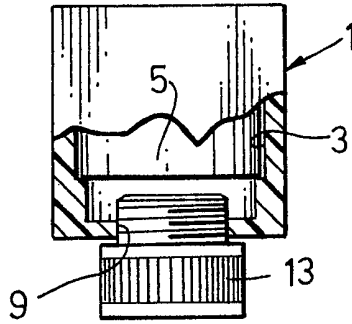

FIG. 1

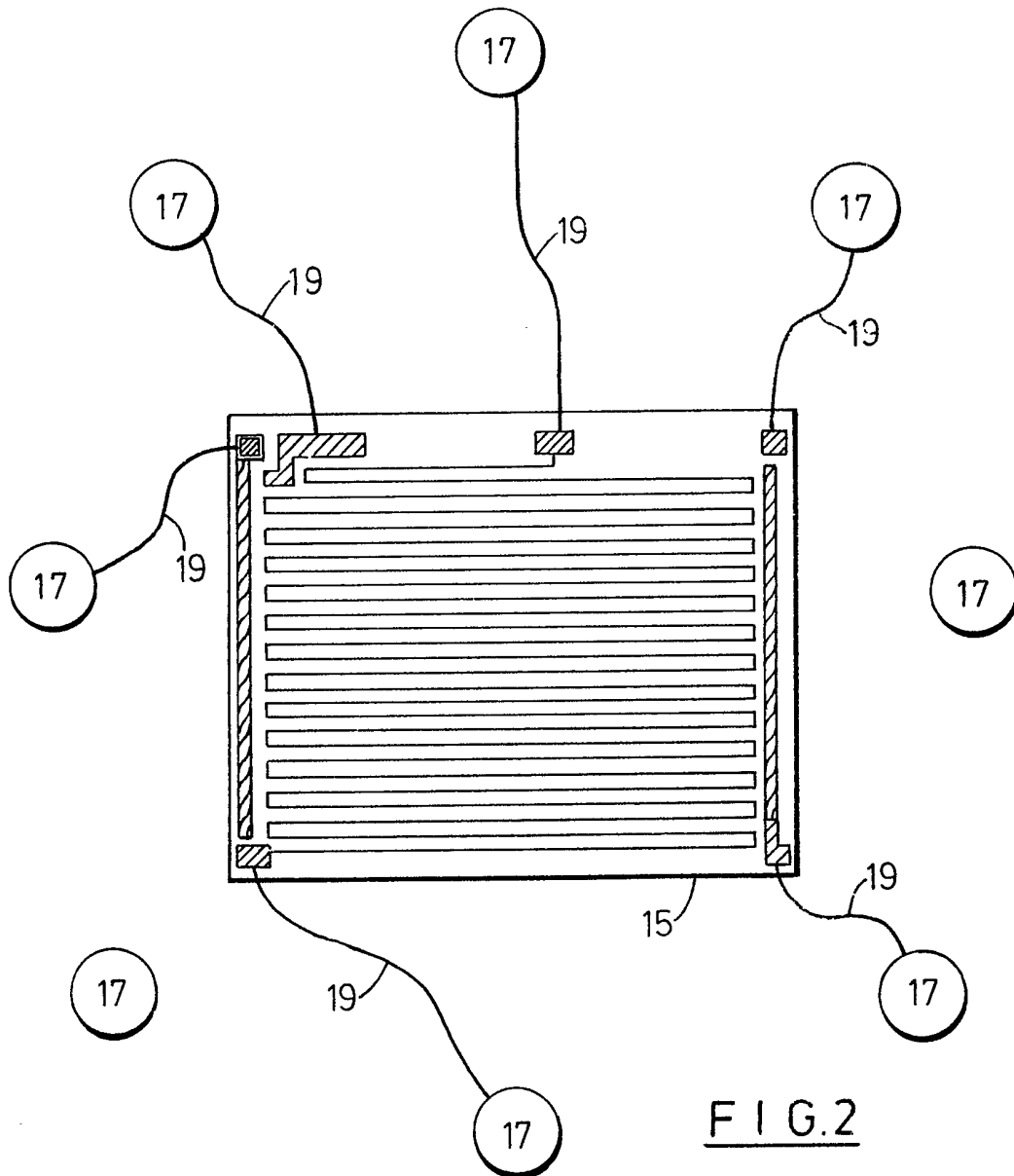

FIG. 2

SPECIFICATION

Image recording device

5 The present invention relates to a visual image recording device.

Photosensitive solid state semi-conductors have been in use for several years for sensing light and it is known that solid state semi-conductors generally
10 are light sensitive.

The present invention is based on the realisation of the feasibility of using a solid state dynamic shift register to record a visual image.

Accordingly, the present invention provides a
15 visual image recording device comprising a solid state dynamic shift register having the solid state elements thereof exposed so that light may be focussed thereon, and means for focussing light on the said exposed elements.

20 Hereinafter for convenience, the device of the present invention will be referred to as a camera.

An advantage of using a dynamic shift register is that it enables the camera to be made up to occupy very small dimensions and this opens up the

25 possibility of using the camera in circumstances, where due to lack of space, it has not previously been feasible or possible to use a camera. For instance, the camera can be housed in a casing of only some 15 mm cube. The shift register also provides simple
30 connections to external circuitry. Typically six leads would be used i.e. for supply, clock, read and output lines. A preferred chip for the register is 1024 bit register e.g. an AM 2808 produced by Advanced Micro Devices. The HC package is presently preferred.
35 The AM 2808 has re-circulate logic.

The focussing means is preferably an optical lens. Provision is preferably made to vary the lens position so that the focal distance of the camera can be varied.

40 The present invention will now be described, by way of example only, with reference to the accompanying drawing, in which:-

Figure 1 is a diagrammatic sectional elevation of a image recording device of the present invention, and

45 *Figure 2* is an enlarged view of a surface of a dynamic shift register package showing the array of solid state light sensitive, elements.

Referring now to the drawings, the device comprises a plastics moulded casing 1 of cuboid form of
50 some 15 mm each side. The casing is formed with a central bore 3 in which is slid an HC package 5 of a solid state dynamic shift register 7 (*Figure 2*).

The casing is formed with a further bore 9 is what appears in *Figure 1* as the bottom wall 11 thereof,
55 and the bore is screw threaded to receive the barrel of an optical lens 13; the barrel being formed with an external screw thread at one end thereof to screw into bore 9. The package 5 exposes the array 15 (see *Figure 2*) of the active semi-conductor elements of
60 the register so that light gathered by the lens can be focussed on the array. Thus, if the lens is viewing an object in focus, the lens projects an image of the object onto the array.

By this means, the image data are "written" into
65 the register. The data may then be read out in the

ordinary way. Although in the process of reading out the register, a bit in one element of the array will be stepped through the following elements thereof to the output, the read-out time is small in relation to
70 the exposure time of the elements so that there is no obliteration of data. Thus, in operation of the camera, a time is allowed for the array to respond to the image information, this being the exposure time, and then a read out is effected; the procedure being
75 repeated for as long as image information is required. Resolution is adequate to permit ready identification of the image, which, for instance, may be displayed on a TV monitor.

As shown in *Figure 2*, the package contains
80 terminals 17 for leads 19 for the array and external connections may be made in any suitable way.

It is considered that the present invention will find useful application in location and movement control work, for instance, in directing "limbs" of a robot
85 especially of industrial robots or the course thereof if mobile and for general recognition work e.g. it may be used to recognise people or for reading a text.

CLAIMS

- 90
1. A visual image recording device comprising a solid state dynamic shift register having the solid state elements thereof exposed so that light may be focussed thereon, and means for focussing light on
95 the said exposed elements.
 2. A recording device according to Claim 1, wherein the register is a 1024 bit register chip.
 3. A recording device according to Claim 1 or 2, wherein the register is packaged as an HC package.
 - 100 4. A recording device according to any of the preceding claims, wherein the register has a re-circulate logic.
 5. A recording device according to any of the preceding claims, wherein the focussing means is an
105 optical lens.
 6. A recording device according to Claim 5, wherein the optical lens is arranged so that the focal distance of the device can be varied.
 7. A recording device substantially as hereinbefore described with reference to the accompanying
110 drawings.