



US00D930862S

(12) **United States Design Patent**  
**Gander et al.**

(10) **Patent No.:** **US D930,862 S**  
(45) **Date of Patent:** **\*\* Sep. 14, 2021**

(54) **VEHICLE HOOD**

- (71) Applicant: **Oshkosh Corporation**, Oshkosh, WI (US)
- (72) Inventors: **Jesse Gander**, Larsen, WI (US);  
**Christopher Yakes**, Oshkosh, WI (US)
- (73) Assignee: **Oshkosh Corporation**, Oshkosh, WI (US)
- (\*\*) Term: **15 Years**
- (21) Appl. No.: **29/765,018**
- (22) Filed: **Jan. 5, 2021**

**Related U.S. Application Data**

(63) Continuation of application No. 29/735,597, filed on May 22, 2020, now Pat. No. Des. 909,934, which is a continuation of application No. 29/706,533, filed on Sep. 20, 2019, now Pat. No. Des. 888,629, which is a continuation of application No. 29/680,745, filed on Feb. 19, 2019, now Pat. No. Des. 871,283, which is a continuation of application No. 29/621,958, filed on Oct. 12, 2017, now Pat. No. Des. 843,281, which is a  
(Continued)

- (51) **LOC (13) Cl.** ..... **26-06**
- (52) **U.S. Cl.**  
USPC ..... **D26/28**; D12/173
- (58) **Field of Classification Search**  
USPC ..... D26/28, 29, 30, 31, 32, 33, 34, 35, 36,  
D26/139; D12/86, 91, 93, 163, 164, 166,  
D12/167, 169, 171, 172, 173, 190, 216  
CPC ..... F21S 48/00; F21S 48/10; F21S 48/115;  
F21S 48/225; F21S 48/1233; F21S  
48/1266; F21S 48/1388; F21S 48/2268;  
F21V 21/04; F21W 2102/17; F21W  
2102/30; F21W 2103/00; F21W 2103/35;  
F21W 2103/55; B60Q 9/135; B60Q  
9/1375

See application file for complete search history.

(56) **References Cited**

**U.S. PATENT DOCUMENTS**

1,001,863 A 8/1911 Kirkwood  
1,278,460 A 9/1918 Hanger  
(Continued)

**FOREIGN PATENT DOCUMENTS**

CA 2478228 A1 2/2006  
DE 11 86 334 1/1965  
(Continued)

**OTHER PUBLICATIONS**

Vehicle Headlights. (Design—© Questel) orbit.com. [online PDF] 38 pgs. Print Dates Range Mar. 19, 2021-May 23, 2019 [Retrieved Apr. 23, 2021].\*

(Continued)

*Primary Examiner* — Manpreet S Matharu  
*Assistant Examiner* — Suzanne E Tisdell  
(74) *Attorney, Agent, or Firm* — Foley & Lardner LLP

(57) **CLAIM**

We claim the ornamental design for a vehicle hood, as shown and described.

**DESCRIPTION**

FIG. 1 is a front perspective view of the claimed design;  
FIG. 2 is a front view of the claimed design;  
FIG. 3 is a rear view of the claimed design;  
FIG. 4 is a left side view of the claimed design;  
FIG. 5 is a right side view of the claimed design;  
FIG. 6 is a top view of the claimed design;  
FIG. 7 is a bottom view of the claimed design; and,  
FIG. 8 is a detailed front perspective view of the claimed design.

The ornamental design that is claimed is shown in solid lines in the figures. Evenly-spaced broken lines depict unclaimed environmental subject matter.

**1 Claim, 8 Drawing Sheets**

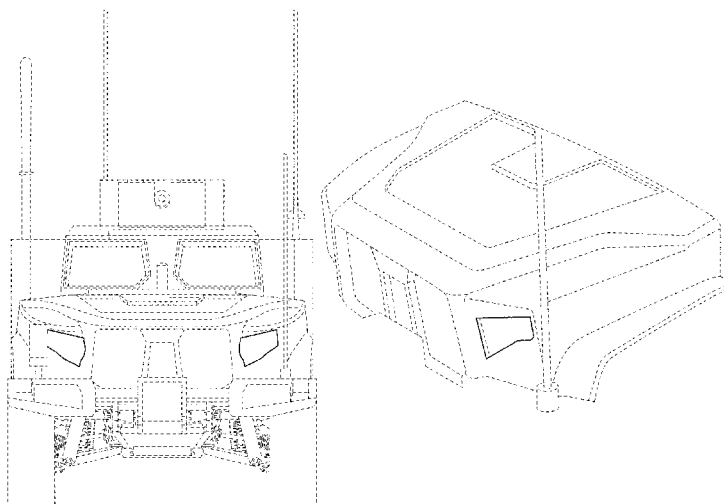

**Related U.S. Application Data**

continuation of application No. 14/612,100, filed on Feb. 2, 2015, now Pat. No. 9,829,282, which is a continuation of application No. 13/629,009, filed on Sep. 27, 2012, now Pat. No. 8,943,946, which is a continuation of application No. 15/599,174, filed on May 18, 2017, now Pat. No. 10,434,995, which is a continuation of application No. 14/724,279, filed on May 28, 2015, now Pat. No. 9,656,640, which is a continuation of application No. 13/841,686, filed on Mar. 15, 2013, now Pat. No. 9,045,014.

(56)

**References Cited**

## U.S. PATENT DOCUMENTS

1,376,467 A	5/1921	Simmon	5,028,088 A	7/1991	Del Monico et al.
1,463,569 A	7/1923	Bathrick	5,040,823 A	8/1991	Lund
1,835,132 A	12/1931	Anania	5,054,806 A	10/1991	Chester
1,941,582 A	1/1934	Schroeder	5,076,597 A	12/1991	Korekane et al.
2,628,127 A	2/1953	Palsgrove	5,080,392 A	1/1992	Bazergui
2,632,577 A	3/1953	Sacco	5,111,901 A	5/1992	Bachhuber et al.
2,907,575 A	10/1959	Locker	5,113,946 A	5/1992	Cooper
2,915,334 A	12/1959	Barenyi	5,137,101 A	8/1992	Schaeff
2,916,997 A	12/1959	Terrie	5,137,292 A	8/1992	Eisen
2,997,242 A	8/1961	Grosholz	5,139,104 A	8/1992	Moscicki
3,010,533 A	11/1961	Ross	5,143,326 A	9/1992	Parks
3,021,166 A	2/1962	Kempel et al.	5,158,614 A	10/1992	Takeuchi
3,039,788 A	6/1962	Farago	5,169,197 A	12/1992	Underbakke et al.
3,046,045 A	7/1962	Campbell	5,209,003 A	5/1993	Maxfield et al.
3,083,790 A	4/1963	McAfee et al.	5,211,245 A	5/1993	Relyea et al.
3,131,963 A	5/1964	Schilberg	5,217,083 A	6/1993	Bachhuber et al.
3,146,839 A	9/1964	Carlson	5,301,756 A	4/1994	Relyea et al.
3,188,966 A	6/1965	Tetlow	5,319,436 A	6/1994	Manns et al.
3,306,390 A	2/1967	Jamme	5,322,321 A	6/1994	Yopp
3,395,672 A	8/1968	Ruf	5,327,989 A	7/1994	Furuhashi et al.
3,500,961 A	3/1970	Eberhardt et al.	5,346,334 A	9/1994	Einaru et al.
3,590,948 A	7/1971	Milner, Jr.	5,368,317 A	11/1994	McCombs et al.
3,726,308 A	4/1973	Eberhardt	5,390,945 A	2/1995	Orr
3,881,767 A	5/1975	Klees	5,438,908 A	8/1995	Madden, Jr.
4,037,664 A	7/1977	Gibson	5,467,827 A	11/1995	McLoughlin
4,059,170 A	11/1977	Young	5,476,202 A	12/1995	Lipp
4,084,522 A	4/1978	Younger	5,487,323 A	1/1996	Madden, Jr.
4,103,757 A	8/1978	McVaugh	5,501,288 A	3/1996	Ducote
4,153,262 A	5/1979	Diamond et al.	5,533,781 A	7/1996	Williams
4,157,733 A	6/1979	Ewers et al.	5,538,185 A	7/1996	Rabitsch et al.
4,160,492 A	7/1979	Johnston	5,538,274 A	7/1996	Schmitz et al.
4,185,924 A	1/1980	Graham	5,549,230 A	8/1996	Palmen
4,241,803 A	12/1980	Lauber	5,553,673 A	9/1996	Hackman
4,270,771 A	6/1981	Fujii	5,617,696 A	4/1997	Young
4,326,445 A	4/1982	Bemiss	5,663,520 A	9/1997	Ladika et al.
4,329,109 A	5/1982	Den Bleyker	5,670,734 A	9/1997	Middione et al.
4,337,830 A	7/1982	Eberhardt	5,679,918 A	10/1997	Korpi et al.
4,369,010 A	1/1983	Ichinose et al.	5,687,669 A	11/1997	Engler
4,373,600 A	2/1983	Buschbom et al.	5,716,066 A	2/1998	Chou et al.
4,395,191 A	7/1983	Kaiser	5,746,396 A	5/1998	Thorton-Trump
4,456,093 A	6/1984	Finley et al.	5,752,862 A	5/1998	Mohler et al.
4,492,282 A	1/1985	Appelblatt et al.	5,785,372 A	7/1998	Glatzmeier et al.
4,558,758 A	12/1985	Littman et al.	5,788,158 A	8/1998	Relyea
4,563,124 A	1/1986	Eskew	5,794,966 A	8/1998	MacLeod
4,586,743 A	5/1986	Edwards et al.	5,807,056 A	9/1998	Osborn et al.
4,587,862 A	5/1986	Hoffman	5,820,150 A	10/1998	Archer et al.
4,655,307 A	4/1987	Lamoureux	D400,835 S	11/1998	Le Quement et al.
4,659,104 A	4/1987	Tanaka et al.	5,836,657 A	11/1998	Tilley et al.
4,669,744 A	6/1987	Sano et al.	5,839,664 A	11/1998	Relyea
4,696,489 A	9/1987	Fujishiro et al.	RE36,196 E	4/1999	Eberhardt
4,709,358 A	11/1987	Appling et al.	5,897,123 A	4/1999	Cherney et al.
4,733,876 A	3/1988	Heider et al.	5,899,276 A	5/1999	Relyea et al.
4,811,804 A	3/1989	Ewers et al.	5,900,199 A	5/1999	Dickson et al.
4,826,141 A	5/1989	Buma et al.	5,905,225 A	5/1999	Joynt
4,834,418 A	5/1989	Buma et al.	5,909,780 A	6/1999	De Andrade
4,926,954 A	5/1990	Ataka et al.	5,915,728 A	6/1999	Blackburn
4,945,780 A	8/1990	Bosma	5,915,775 A	6/1999	Martin et al.
5,004,156 A	4/1991	Montanier	5,919,240 A	7/1999	Ney et al.
5,010,971 A	4/1991	Hamada et al.	5,954,364 A	9/1999	Nechushtan
5,021,917 A	6/1991	Pike et al.	6,009,953 A	1/2000	Laskaris et al.
			6,015,155 A	1/2000	Brookes et al.
			6,036,201 A	3/2000	Pond et al.
			6,105,984 A	8/2000	Schmitz et al.
			6,109,684 A	8/2000	Reitnouer
			6,131,685 A	10/2000	Sakamoto et al.
			6,155,351 A	12/2000	Breedlove et al.
			6,178,746 B1	1/2001	Thoma et al.
			6,220,532 B1	4/2001	Manon et al.
			6,231,466 B1	5/2001	Thoma et al.
			6,270,098 B1	8/2001	Heyring et al.
			6,270,153 B1	8/2001	Toyao et al.
			6,289,995 B1	9/2001	Fuller
			6,311,795 B1	11/2001	Skotnikov et al.
			6,318,742 B2	11/2001	Franzini
			6,357,769 B1	3/2002	Omundson et al.
			6,364,597 B2	4/2002	Klinkenberg
			6,394,007 B2	5/2002	Lewis et al.
			6,394,534 B1	5/2002	Dean
			6,398,236 B1	6/2002	Richardson

(56)

## References Cited

## U.S. PATENT DOCUMENTS

6,398,478	B2	6/2002	Smith et al.	D561,665	S	2/2008	Thomas et al.
6,421,593	B1	7/2002	Kempen et al.	7,329,161	B2	2/2008	Roering
6,435,071	B1	8/2002	Campbell	D563,289	S	3/2008	Pfeiffer
6,435,298	B1	8/2002	Mizuno et al.	7,357,203	B2	4/2008	Morrow et al.
6,443,687	B1	9/2002	Kaiser	D568,217	S	5/2008	Tomatsu et al.
6,460,907	B2	10/2002	Usui	7,377,549	B2	5/2008	Hasegawa et al.
6,503,035	B1	1/2003	Perrott	7,379,797	B2	5/2008	Nasr et al.
6,516,914	B1	2/2003	Andersen et al.	7,380,800	B2	6/2008	Klees
6,520,494	B1	2/2003	Andersen et al.	7,392,122	B2	6/2008	Pillar et al.
6,527,494	B2	3/2003	Hurlburt	7,393,016	B2	7/2008	Mitsui et al.
D473,829	S	4/2003	Hoyle, Jr.	7,406,909	B2	8/2008	Shah et al.
6,553,290	B1	4/2003	Pillar	7,412,307	B2	8/2008	Pillar et al.
D474,430	S *	5/2003	Hill ..... D12/184	7,419,021	B2	9/2008	Morrow et al.
6,561,718	B1	5/2003	Archer et al.	7,425,891	B2	9/2008	Colburn et al.
6,619,673	B2	9/2003	Eckelberry et al.	7,439,711	B2	10/2008	Bolton
6,623,020	B1	9/2003	Satou	7,441,615	B2	10/2008	Borroni-Bird et al.
6,658,984	B2	12/2003	Zonak	7,441,809	B1	10/2008	Coombs et al.
6,692,366	B1	2/2004	Savant	7,448,460	B2	11/2008	Morrow et al.
6,695,328	B2	2/2004	Cope	7,451,028	B2	11/2008	Pillar et al.
6,702,058	B2	3/2004	Ishii et al.	7,472,914	B2	1/2009	Anderson et al.
6,736,232	B1	5/2004	Bergstrom et al.	7,472,919	B2	1/2009	Pratt et al.
6,757,597	B2	6/2004	Yakes et al.	7,510,235	B2	3/2009	Kobayashi et al.
6,764,085	B1	7/2004	Anderson	7,520,354	B2	4/2009	Morrow et al.
6,769,733	B2	8/2004	Seksaria et al.	7,522,979	B2	4/2009	Pillar
6,779,806	B1	8/2004	Breitbach et al.	7,555,369	B2	6/2009	Pillar et al.
D497,849	S	11/2004	Yanase	D597,002	S	7/2009	Jamieson et al.
6,820,908	B1	11/2004	Tousi et al.	7,594,561	B2	9/2009	Hass et al.
6,848,693	B2	2/2005	Schneider	7,611,153	B2	11/2009	Kim et al.
6,860,332	B1	3/2005	Archer et al.	7,611,154	B2	11/2009	Delaney
6,882,917	B2	4/2005	Pillar et al.	7,618,063	B2	11/2009	Takeshima et al.
6,883,815	B2	4/2005	Archer	7,624,835	B2	12/2009	Bowers
6,885,920	B2	4/2005	Yakes et al.	7,624,995	B2	12/2009	Barbison
6,899,191	B1	5/2005	Lykken	7,641,268	B2 *	1/2010	Goffart ..... B60Q 1/0458 296/193.11
6,909,944	B2	6/2005	Pillar et al.	7,681,892	B1	3/2010	Crews et al.
6,922,615	B2	7/2005	Pillar et al.	7,689,332	B2	3/2010	Yakes et al.
6,923,453	B2	8/2005	Pivac	7,695,053	B1	4/2010	Boczek et al.
6,925,735	B2	8/2005	Hamm et al.	7,699,385	B2	4/2010	Kurata
6,959,466	B2	11/2005	Alowonle et al.	7,711,460	B2	5/2010	Yakes et al.
6,976,688	B2	12/2005	Archer et al.	7,715,962	B2	5/2010	Rowe et al.
6,993,421	B2	1/2006	Pillar et al.	7,725,225	B2	5/2010	Pillar et al.
7,006,902	B2	2/2006	Archer et al.	D617,255	S	6/2010	Tezak et al.
7,024,296	B2	4/2006	Squires et al.	7,726,429	B2	6/2010	Suzuki
D523,381	S	6/2006	Taguchi et al.	7,729,831	B2	6/2010	Pillar et al.
7,072,745	B2	7/2006	Pillar et al.	D619,062	S	7/2010	Improta
7,073,620	B2	7/2006	Braun et al.	7,756,621	B2	7/2010	Pillar et al.
D528,482	S	9/2006	Hamburger	7,757,805	B2	7/2010	Wakuta et al.
7,107,129	B2	9/2006	Rowe et al.	7,770,506	B2	8/2010	Johnson et al.
7,114,764	B1	10/2006	Barsoum et al.	D623,100	S	9/2010	Bimbi
7,127,331	B2	10/2006	Pillar et al.	D623,565	S	9/2010	Cogswell
D533,485	S	12/2006	Schiavone et al.	7,789,010	B2	9/2010	Allor et al.
7,144,039	B2	12/2006	Kawasaki et al.	7,792,618	B2	9/2010	Quigley et al.
D535,589	S	1/2007	Lau et al.	7,802,816	B2	9/2010	McGuire
7,162,332	B2	1/2007	Pillar et al.	D627,686	S	11/2010	Thompson et al.
7,164,977	B2	1/2007	Yakes et al.	7,835,838	B2	11/2010	Pillar et al.
7,184,662	B2	2/2007	Arbel et al.	7,848,857	B2	12/2010	Nasr et al.
7,184,862	B2	2/2007	Pillar et al.	7,905,534	B2	3/2011	Boczek et al.
7,184,866	B2	2/2007	Squires et al.	7,905,540	B2	3/2011	Kiley et al.
7,188,893	B2	3/2007	Akasaka	7,908,959	B2	3/2011	Pavon
7,198,130	B2	4/2007	Schimke	D636,305	S	4/2011	Alvarez et al.
7,198,278	B2	4/2007	Donaldson	7,931,103	B2	4/2011	Morrow et al.
7,207,582	B2	4/2007	Siebers et al.	7,934,766	B2	5/2011	Boczek et al.
7,213,872	B2	5/2007	Ronacher et al.	7,938,478	B2	5/2011	Kamimae
7,234,534	B2	6/2007	Froland et al.	D642,099	S	7/2011	Nagao et al.
7,240,906	B2	7/2007	Klees	7,997,182	B1	8/2011	Cox
7,246,835	B1	7/2007	Colburn et al.	8,000,850	B2	8/2011	Nasr et al.
7,254,468	B2	8/2007	Pillar et al.	D646,203	S	10/2011	Thompson et al.
7,258,194	B2	8/2007	Braun et al.	D646,607	S	10/2011	Verhee et al.
7,267,394	B1	9/2007	Mouch et al.	8,029,021	B2	10/2011	Leonard et al.
7,270,346	B2	9/2007	Rowe et al.	8,033,208	B2	10/2011	Joynt et al.
7,274,976	B2	9/2007	Rowe et al.	D649,908	S	12/2011	Mullen
D552,522	S	10/2007	Sandy et al.	D649,909	S	12/2011	Mullen
7,277,782	B2	10/2007	Yakes et al.	8,095,247	B2	1/2012	Pillar et al.
7,281,600	B2	10/2007	Chernoff et al.	8,096,225	B1	1/2012	Johnson et al.
7,302,320	B2	11/2007	Nasr et al.	D655,226	S	3/2012	Hanson et al.
7,306,069	B2	12/2007	Takeshima et al.	8,139,109	B2	3/2012	Schmiedel et al.
				8,146,477	B2	4/2012	Joynt
				8,146,478	B2	4/2012	Joynt et al.
				D661,231	S	6/2012	Galante et al.

(56)

References Cited

U.S. PATENT DOCUMENTS

8,205,703	B2	6/2012	Halliday	D794,853	S	*	8/2017	Lai	.....	D26/28
D662,865	S	7/2012	Van Braeckel	D796,715	S	*	9/2017	Lin	.....	D26/28
8,333,390	B2	12/2012	Linsmeier et al.	D797,332	S	*	9/2017	Lin	.....	D26/28
8,347,775	B2	1/2013	Altenhof et al.	D797,603	S		9/2017	Noone et al.		
8,376,077	B2	2/2013	Venton-Walters	D802,491	S		11/2017	Mainville		
8,402,878	B2	3/2013	Schreiner et al.	D804,065	S	*	11/2017	Lai	.....	D26/28
8,413,567	B2	4/2013	Luther et al.	D804,372	S		12/2017	Kozub		
8,413,568	B2	4/2013	Kosheleff	D805,965	S		12/2017	Davis		
8,424,443	B2	4/2013	Gonzalez	D805,968	S		12/2017	Piscitelli et al.		
8,430,196	B2	4/2013	Halliday	D813,757	S		3/2018	Kozub		
D683,675	S	6/2013	Munson et al.	D813,758	S		3/2018	Gonzales		
8,459,619	B2	6/2013	Trinh et al.	D815,574	S		4/2018	Mainville		
8,465,025	B2	6/2013	Venton-Walters et al.	D818,885	S		5/2018	Seo		
D686,121	S	7/2013	McCabe et al.	D820,179	S		6/2018	Kladde		
8,561,735	B2	10/2013	Morrow et al.	D823,182	S		7/2018	Yates		
8,578,834	B2	11/2013	Tunis et al.	D823,183	S		7/2018	Yates		
8,596,183	B2	12/2013	Coltrane	D824,294	S		7/2018	Ge et al.		
8,596,648	B2	12/2013	Venton-Walters et al.	10,023,243	B2		7/2018	Hines et al.		
8,601,931	B2	12/2013	Naroditsky et al.	D824,811	S		8/2018	Mainville		
8,616,617	B2	12/2013	Sherbeck et al.	D824,814	S		8/2018	Heyde		
D698,281	S	1/2014	Badstuebner et al.	D827,410	S		9/2018	Earley		
8,635,776	B2	1/2014	Newberry et al.	D828,258	S		9/2018	Zipfel		
D702,615	S	4/2014	Conway et al.	D830,242	S		10/2018	Zipfel		
D703,119	S	4/2014	Platto et al.	D837,106	S		1/2019	Yang		
8,746,741	B2	6/2014	Gonzalez	D837,702	S		1/2019	Gander et al.		
8,764,029	B2	7/2014	Venton-Walters et al.	D843,281	S		3/2019	Gander et al.		
8,801,017	B2	8/2014	Ellifson et al.	D849,283	S	*	5/2019	Lin	.....	D26/28
D714,476	S	9/2014	Lai	D850,676	S	*	6/2019	Lin	.....	D26/28
8,863,884	B2	10/2014	Jacob-Lloyd	D853,285	S		7/2019	Yang		
D718,683	S	12/2014	Thole et al.	D856,860	S		8/2019	Gander		
8,905,164	B1	12/2014	Capouellez et al.	D859,226	S		9/2019	Grooms		
8,921,130	B2	12/2014	Kundaliya et al.	D860,887	S		9/2019	Gander et al.		
8,943,946	B1	2/2015	Richmond et al.	D862,752	S	*	10/2019	Lai	.....	D26/28
8,944,497	B2	2/2015	Dryselius et al.	D863,144	S		10/2019	Gander		
8,947,531	B2	2/2015	Fischer et al.	D864,031	S		10/2019	Gander et al.		
8,955,859	B1	2/2015	Richmond et al.	D864,802	S		10/2019	Davis et al.		
D725,555	S	3/2015	Wolff et al.	D865,601	S	*	11/2019	Goodrich	.....	D12/190
8,967,699	B1	3/2015	Richmond et al.	D869,332	S		12/2019	Gander et al.		
8,991,834	B2	3/2015	Venton-Walters et al.	10,609,874	B1		4/2020	Shumaker		
8,991,840	B2	3/2015	Zuleger et al.	D883,876	S		5/2020	Beasley et al.		
9,016,703	B2	4/2015	Rowe et al.	D887,050	S	*	6/2020	Lin	.....	D26/28
D728,435	S	5/2015	Hanson et al.	D893,066	S	*	8/2020	Lin	.....	D26/28
9,045,014	B1	6/2015	Verhoff et al.	D894,442	S	*	8/2020	Lin	.....	D26/28
D735,625	S	8/2015	Mays et al.	D897,010	S	*	9/2020	Momokawa	.....	D26/28
D739,317	S	9/2015	McMahan et al.	D898,244	S	*	10/2020	Badstuebner	.....	D26/28
D740,187	S	10/2015	Jamieson	D904,227	S	*	12/2020	Bracy	.....	D12/85
9,156,507	B1	10/2015	Reed	D904,240	S		12/2020	Heilaneh et al.		
D742,287	S	11/2015	Hanson et al.	D906,902	S		1/2021	Duncan et al.		
D743,308	S	11/2015	Hanson et al.	D908,935	S	*	1/2021	Lin	.....	D26/28
D743,856	S	11/2015	Ma	D909,639	S	*	2/2021	Chen	.....	D26/28
9,174,686	B1	11/2015	Messina et al.	D909,641	S	*	2/2021	Chen	.....	D26/28
D745,986	S	12/2015	Gorsten Schuenemann ..	D909,644	S	*	2/2021	Chen	.....	D26/28
9,221,496	B2	12/2015	Barr et al.	D910,502	S		2/2021	Duncan et al.		
D749,464	S	2/2016	Giolito	2001/0015559	A1		8/2001	Storer		
D754,039	S	4/2016	Behmer et al.	2002/0129696	A1		9/2002	Pek et al.		
9,328,986	B1	5/2016	Pennau et al.	2002/0130771	A1		9/2002	Osborne et al.		
D762,148	S	7/2016	Platto et al.	2002/0153183	A1		10/2002	Puterbaugh et al.		
9,409,471	B2	8/2016	Hoppe et al.	2002/0190516	A1		12/2002	Henksmeier et al.		
D765,566	S	9/2016	Vena et al.	2003/0001346	A1		1/2003	Hamilton et al.		
D768,320	S	10/2016	Lai	2003/0155164	A1		8/2003	Mantini et al.		
D769,160	S	10/2016	Platto et al.	2004/0113377	A1		6/2004	Klees		
D772,768	S	11/2016	Chiang	2004/0130168	A1		7/2004	O'Connell		
D774,994	S	12/2016	Alemanly et al.	2004/0149500	A1		8/2004	Chernoff et al.		
D775,021	S	12/2016	Harriton et al.	2004/0256024	A1		12/2004	Schlachter		
D777,220	S	1/2017	Powell	2005/0034911	A1		2/2005	Darby		
D777,615	S	1/2017	Hanson et al.	2005/0062239	A1		3/2005	Shore		
D778,217	S	2/2017	Ito et al.	2005/0093265	A1		5/2005	Niaura et al.		
D782,711	S	3/2017	Dunshee	2005/0099885	A1		5/2005	Tamminga		
D784,219	S	4/2017	Jung	2005/0110229	A1		5/2005	Kimura et al.		
D787,993	S	5/2017	McCabe et al.	2005/0132873	A1		6/2005	Diaz Supisiche et al.		
9,650,005	B2	5/2017	Patelczyk et al.	2005/0161891	A1		7/2005	Trudeau et al.		
9,656,640	B1	5/2017	Verhoff et al.	2005/0196269	A1		9/2005	Racer et al.		
D789,840	S	6/2017	Curic et al.	2005/0284682	A1		12/2005	Hass et al.		
D790,409	S	6/2017	Baste	2006/0021764	A1		2/2006	Archer et al.		
D791,987	S	7/2017	Lin	2006/0048986	A1		3/2006	Bracciano		
				2006/0082079	A1		4/2006	Eichhorn et al.		
				2006/0192354	A1		8/2006	Van Cayzeele		
				2006/0201727	A1		9/2006	Chan		
				2006/0244225	A1		11/2006	Power et al.		

(56)

## References Cited

## U.S. PATENT DOCUMENTS

2006/0273566 A1 12/2006 Hepner et al.  
 2007/0088469 A1 4/2007 Schmiedel et al.  
 2007/0102963 A1 5/2007 Frederick et al.  
 2007/0120334 A1 5/2007 Holbrook  
 2007/0145816 A1 6/2007 Gile  
 2007/0158920 A1 7/2007 Delaney  
 2007/0186762 A1 8/2007 Dehart et al.  
 2007/0234896 A1 10/2007 Joynt  
 2007/0246902 A1 10/2007 Trudeau et al.  
 2008/0017426 A1 1/2008 Walters et al.  
 2008/0017434 A1 1/2008 Harper et al.  
 2008/0034953 A1 2/2008 Barbe et al.  
 2008/0053739 A1 3/2008 Chernoff et al.  
 2008/0066613 A1 3/2008 Mills et al.  
 2008/0099213 A1 5/2008 Morrow et al.  
 2008/0252025 A1 10/2008 Plath  
 2008/0284118 A1 11/2008 Venton-Walters et al.  
 2009/0001761 A1 1/2009 Yasuhara et al.  
 2009/0061702 A1 3/2009 March  
 2009/0174158 A1 7/2009 Anderson et al.  
 2010/0019538 A1 1/2010 Kiley et al.  
 2010/0026046 A1 2/2010 Mendoza et al.  
 2010/0032932 A1 2/2010 Hastings  
 2010/0123324 A1 5/2010 Shoup et al.  
 2010/0163330 A1 7/2010 Halliday  
 2010/0187864 A1 7/2010 Tsuchida  
 2010/0218667 A1 9/2010 Naroditsky et al.  
 2010/0264636 A1 10/2010 Fausch et al.  
 2010/0307328 A1 12/2010 Hoadley et al.  
 2010/0307329 A1 12/2010 Kaswen et al.  
 2010/0319525 A1 12/2010 Pavon  
 2011/0068606 A1 3/2011 Klimek et al.  
 2011/0079134 A1 4/2011 Jacquemont et al.  
 2011/0079978 A1 4/2011 Schreiner et al.  
 2011/0114409 A1 5/2011 Venton-Walters  
 2011/0120791 A1 5/2011 Greenwood et al.  
 2011/0266838 A1 11/2011 Leopold  
 2011/0291444 A1 12/2011 Ische  
 2011/0314999 A1 12/2011 Luther et al.  
 2012/0049570 A1 3/2012 Aizik  
 2012/0097019 A1 4/2012 Sherbeck et al.  
 2012/0111180 A1 5/2012 Johnson et al.  
 2012/0174767 A1 7/2012 Naroditsky et al.  
 2012/0181100 A1 7/2012 Halliday  
 2012/0193940 A1 8/2012 Tunis et al.  
 2013/0009423 A1 1/2013 Yamamoto et al.  
 2013/0093154 A1 4/2013 Cordier et al.  
 2013/0153314 A1 6/2013 Niedzwiecki  
 2013/0205984 A1 8/2013 Henker et al.  
 2013/0241237 A1 9/2013 Dziuba et al.  
 2013/0263729 A1 10/2013 Johnson et al.  
 2013/0312595 A1 11/2013 Lee  
 2014/0035325 A1 2/2014 Naito et al.  
 2014/0060304 A1 3/2014 Harmon et al.  
 2014/0151142 A1 6/2014 Hoppe et al.  
 2014/0262591 A1 9/2014 Turner et al.  
 2015/0224847 A1 8/2015 Rowe et al.  
 2015/0283889 A1 10/2015 Agnew  
 2016/0047631 A1 2/2016 Berman  
 2016/0257360 A1 9/2016 MacKenzie et al.  
 2017/0328054 A1 11/2017 Bakken  
 2017/0355400 A1 12/2017 Weston

2018/0326843 A1 11/2018 Danielson et al.  
 2019/0185077 A1 6/2019 Smith et al.  
 2019/0351883 A1 11/2019 Verhoff et al.

## FOREIGN PATENT DOCUMENTS

DE 36 20 603 A1 1/1987  
 EP 0 685 382 A1 12/1995  
 EP 1 633 619 B1 6/2004  
 EP 1 371 391 B1 12/2009  
 FR 1471914 A 3/1967  
 FR 2380176 A1 9/1978  
 GB 2 168 015 6/1986  
 GB 2 400 588 A 1/2005  
 GB 2 400 589 A 2/2005  
 GB 2 400 590 A 3/2005  
 HK 1088583 10/2007  
 JP 4230421 B2 8/1992  
 JP 06-037090 5/1994  
 JP 2005-007995 A 1/2005  
 JP 2005-212698 A 8/2005  
 JP 2006-056463 A 3/2006  
 WO WO-01/76912 A1 10/2001  
 WO WO-03/049987 A2 6/2003  
 WO WO-2007/140179 A2 12/2007

## OTHER PUBLICATIONS

Iriarte, Mariana. "Power Distribution from the Ground Up." Nov. 9, 2016. Military Embedded Systems. <https://militaryembedded.com/comms/communications/power-distribution-the-ground-up>.\*

Huddleston, Scott. "Fortified Tactical Vehicle Offered to Replace Military Humvee." Jan. 4, 2014. My San Antonio. <https://www.mysanantonio.com/news/local/military/article/Fortified-tactical-vehicle-offered-to-replace-5109387.php#photo-5673528>.\*

"New Oshkosh JLTV Next to an Old Humvee." May 2, 2017. Reddit. [https://www.reddit.com/r/MilitaryPorn/comments/8jfile/new\\_oshkosh\\_jltv\\_next\\_to\\_an\\_old\\_humvee\\_hmmvw\\_may/](https://www.reddit.com/r/MilitaryPorn/comments/8jfile/new_oshkosh_jltv_next_to_an_old_humvee_hmmvw_may/).\*

U.S. Appl. No. 10/171,075, filed Jun. 13, 2002, Archer et al.

U.S. Appl. No. 14/532,679, filed Nov. 4, 2014, Oshkosh Corporation.

U.S. Appl. No. 29/680,745, filed Feb. 19, 2019, Oshkosh Corporation.

U.S. Appl. No. 29/683,330, filed Mar. 12, 2019, Oshkosh Corporation.

U.S. Appl. No. 29/683,333, filed Mar. 12, 2019, Oshkosh Corporation.

U.S. Appl. No. 29/700,665, filed Aug. 5, 2019, Oshkosh Corporation.

U.S. Appl. No. 29/706,533, filed Sep. 20, 2019, Oshkosh Corporation.

U.S. Appl. No. 29/706,547, filed Sep. 20, 2019, Oshkosh Corporation.

2019 Nissan NV1500 Cargo Consumer Reviews, Kelley Blue Book, Apr. 14, 2021, 12 pages, <https://www.kbb.com/nissan/nv1500-cargo/2019/consumer-reviews/>.

Feeburg, Elisabet. "Mine-Resistant, Ambush-Protected All-Terrain Vehcile", 2009. Britannica, <https://www.britannica.com/technology/armoured-vehicle/Wheeled-armoured-vehicles>.

Grille Designs, Questel, orbit.com, Retrieved Apr. 14, 2021, 26 pages.

Miller, Stephen W., "The MRAP Story: Learning from History", Asian Military Review, Oct. 30, 2018, 9 pages.

\* cited by examiner

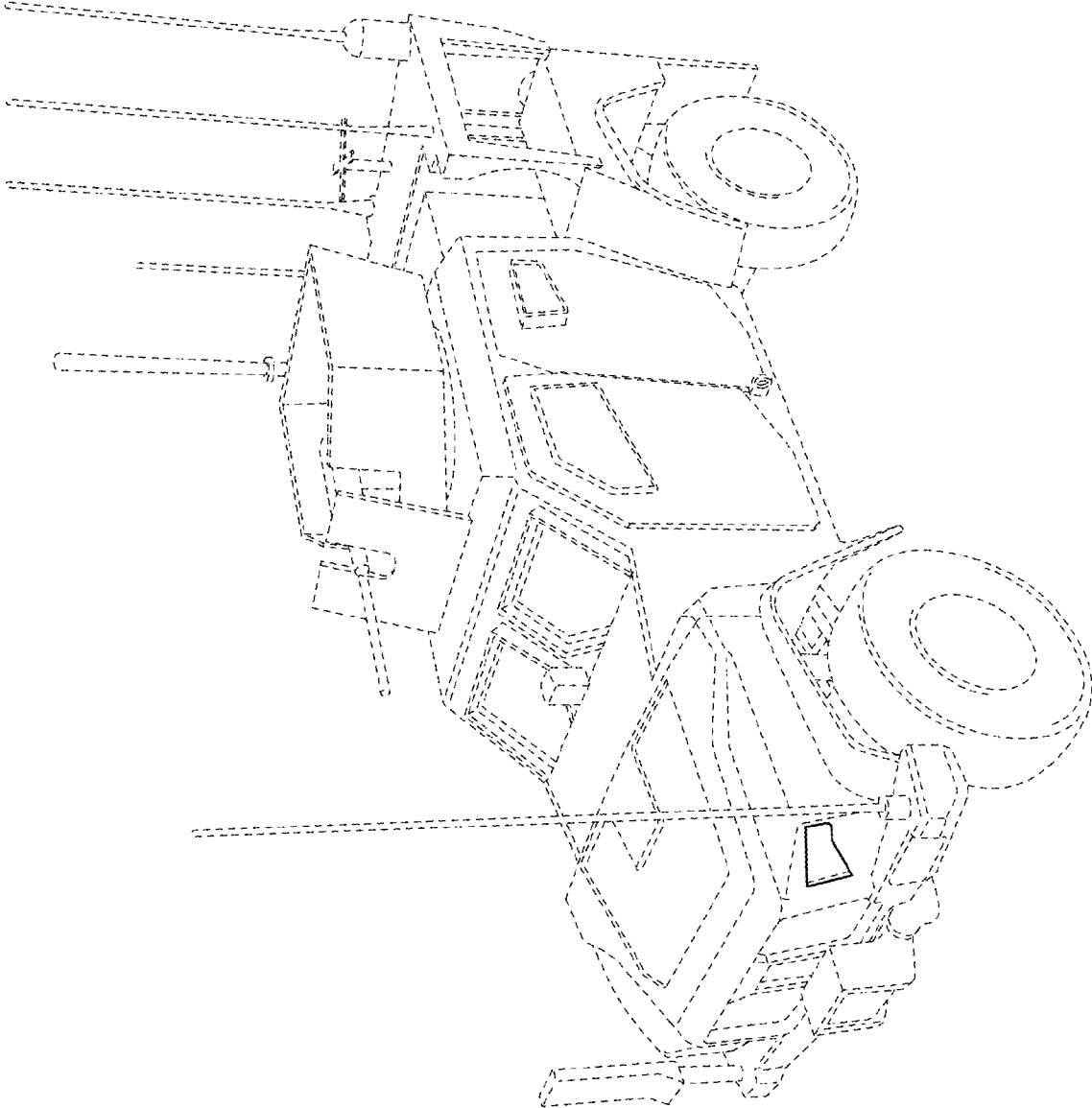

FIG. 1

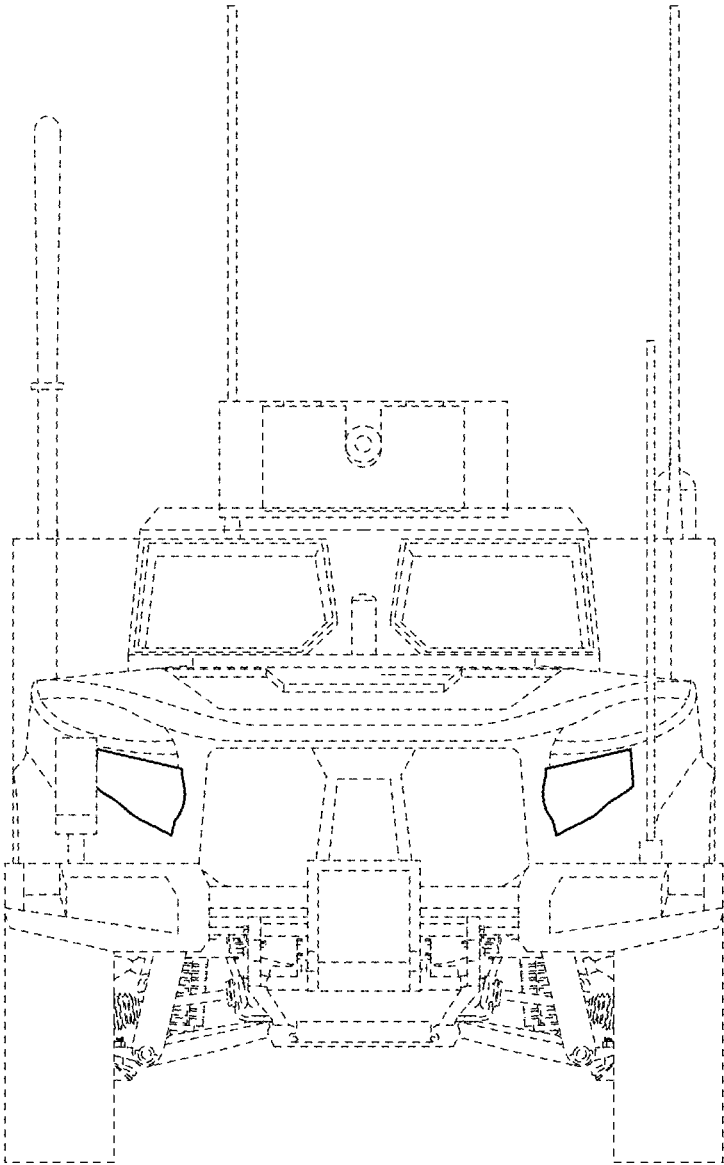

FIG. 2

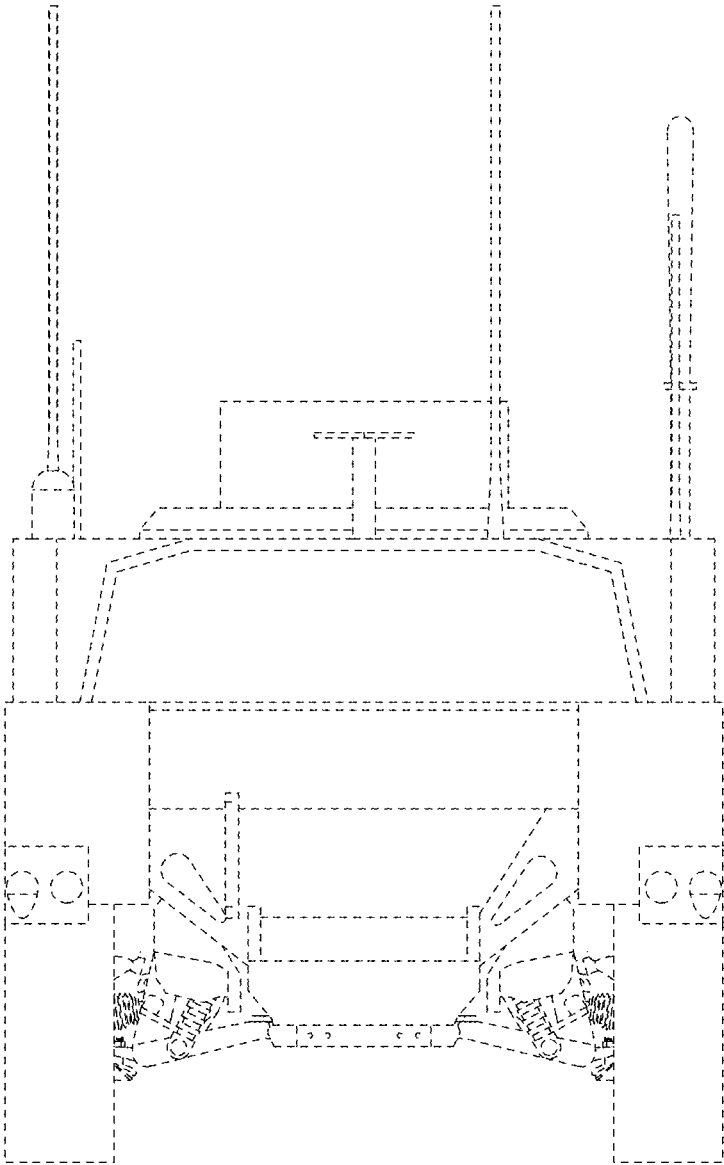

FIG. 3



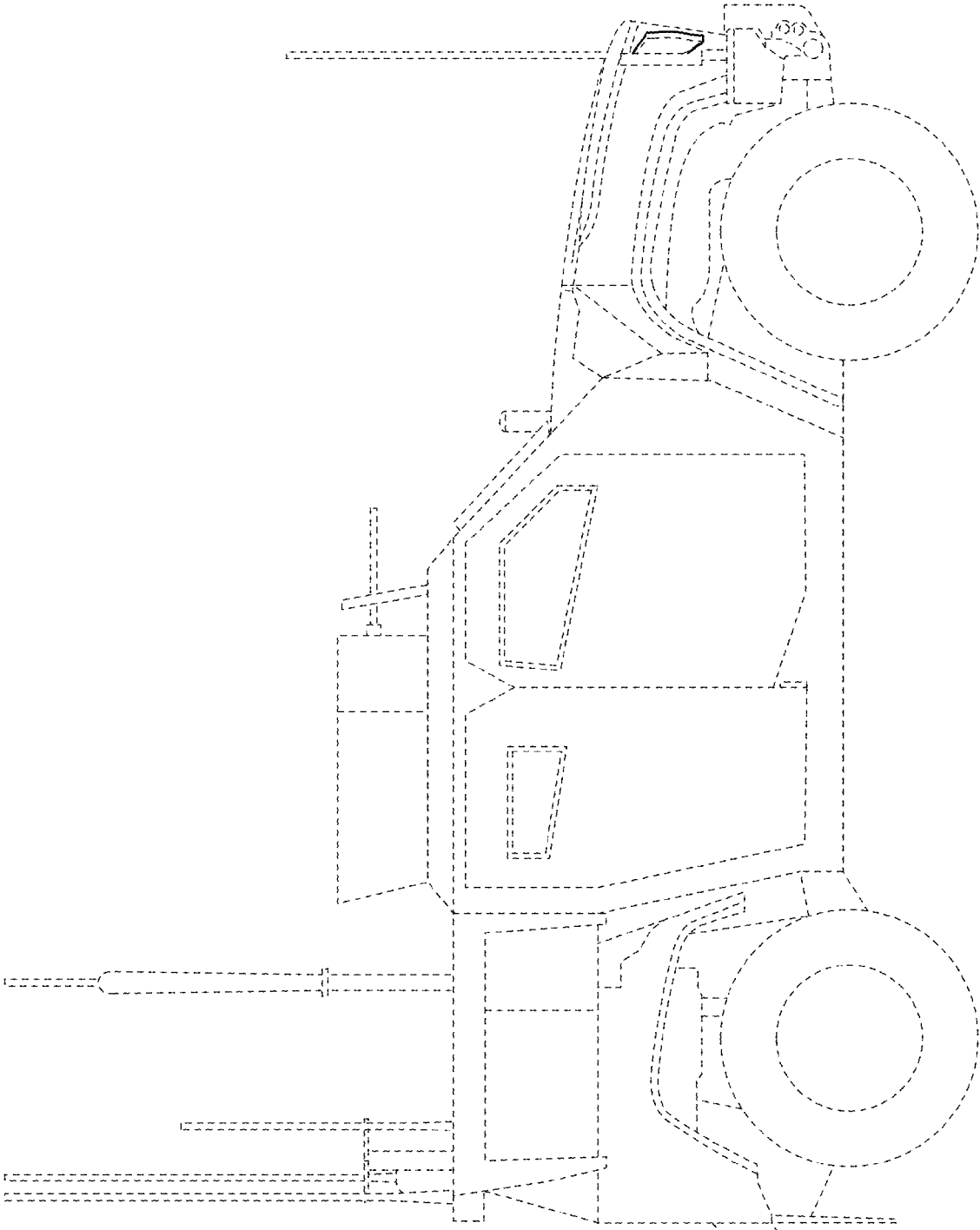

FIG. 4

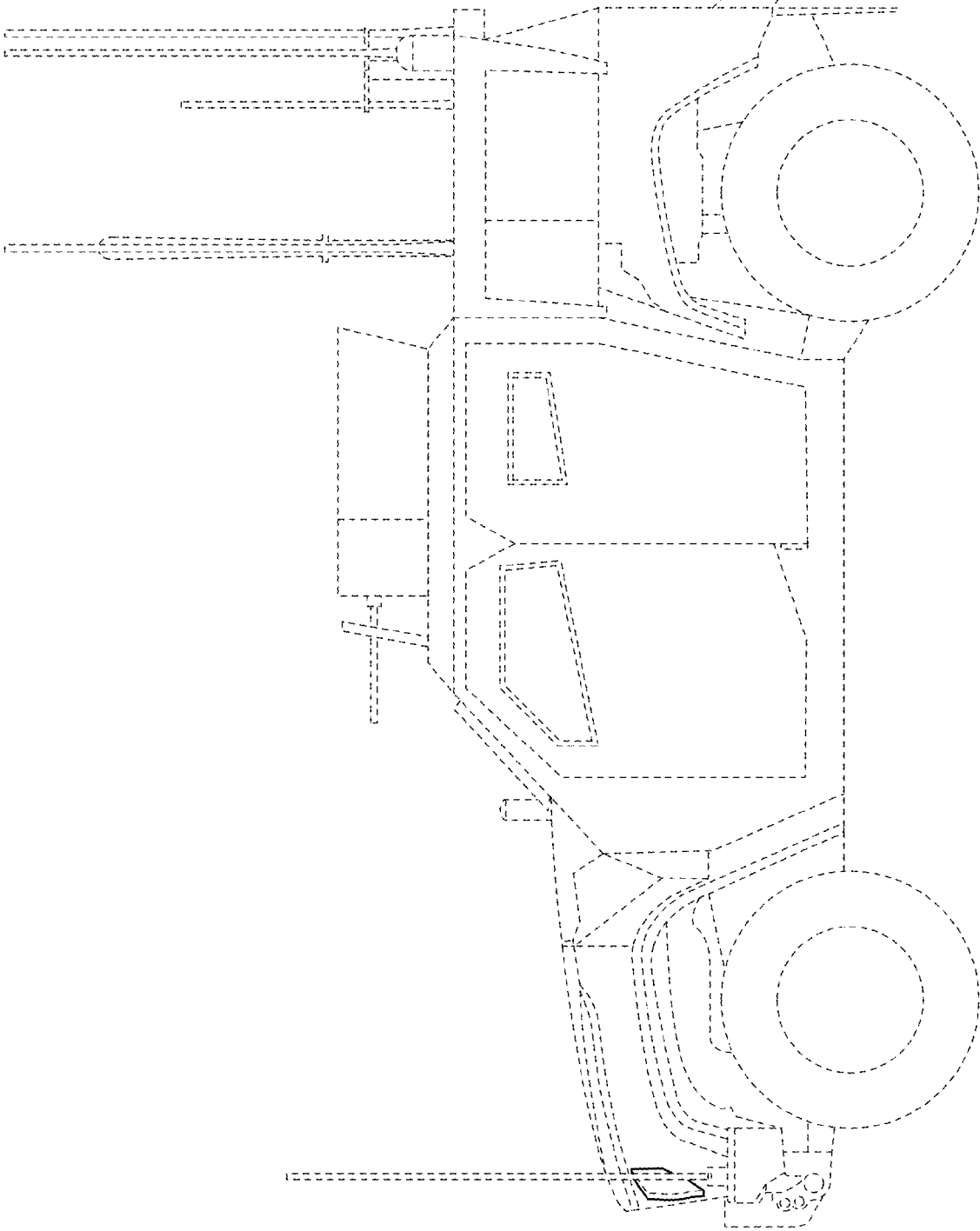

FIG. 5

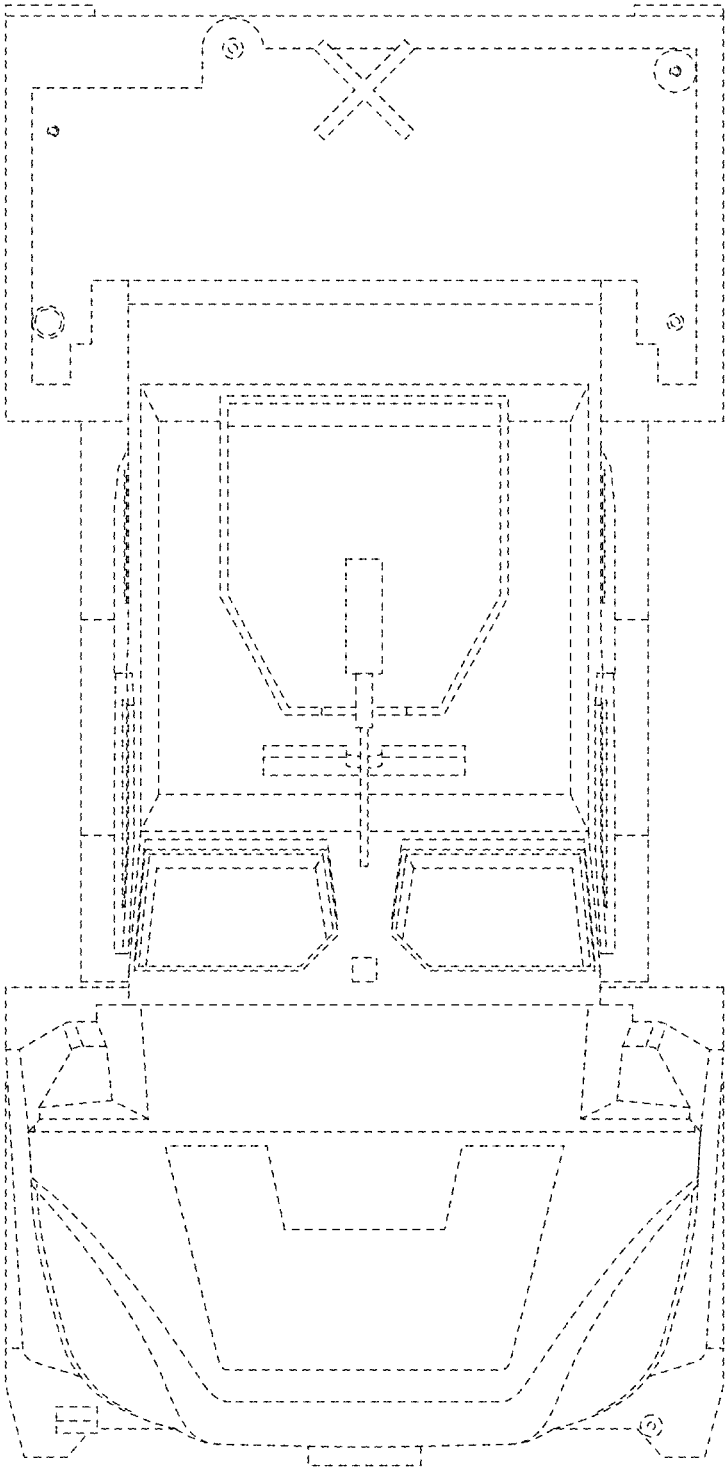

FIG. 6

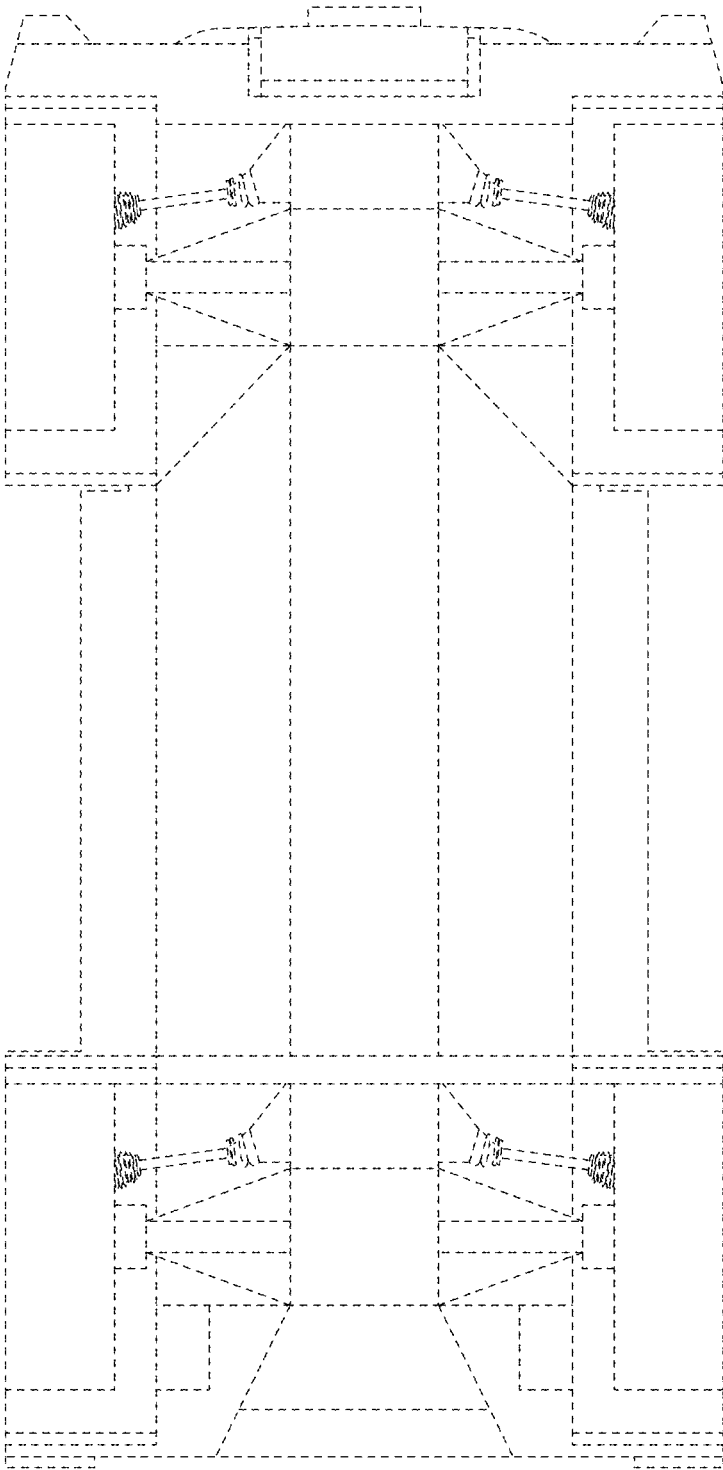

FIG. 7

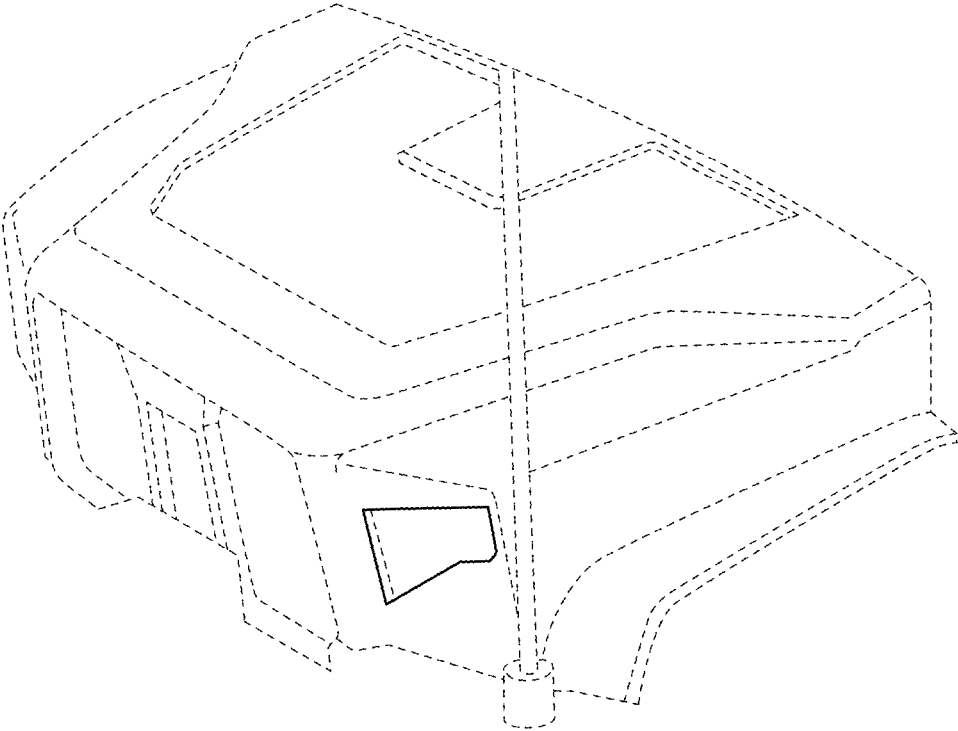

FIG. 8