



(12) **DEMANDE DE BREVET CANADIEN
CANADIAN PATENT APPLICATION**

(13) **A1**

(22) Date de dépôt/Filing Date: 2021/01/15
(41) Mise à la disp. pub./Open to Public Insp.: 2021/07/18
(30) Priorités/Priorities: 2020/01/18 (US16/746839);
2020/01/18 (US16/746838); 2020/01/18 (US16/746836);
2020/01/18 (US16/746833)

(51) Cl.Int./Int.Cl. *F25C 1/04* (2018.01),
F25C 1/12 (2006.01), *F25C 1/25* (2018.01)
(71) Demandeur/Applicant:
TRUE MANUFACTURING CO., INC., US
(72) Inventeurs/Inventors:
KNATT, KEVIN, US;
CAYEMBERG, CURT, US
(74) Agent: SMART & BIGGAR LLP

(54) Titre : MACHINE A FAIRE DE LA GLACE
(54) Title: ICE MAKER

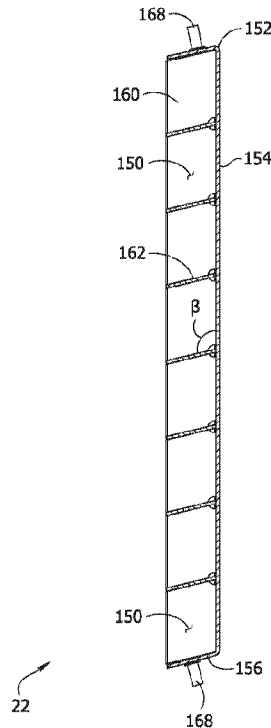

(57) **Abrégé/Abstract:**

An ice maker includes an evaporator configured to freeze water into ice as it flows vertically down a freeze plate. A distributor distributes the water along the top of the freeze plate to form ice across the width of the freeze plate as the water flows downward along the freeze plate. The distributor can be integrated into the evaporator. For example, the distributor and evaporator can have a part in common. The distributor can be formed from two pieces that come together to form the freeze plate. The distributor can have various features that aid in providing a desirable distribution of water along the width of the freeze plate. The freeze plate can be mounted in an ice maker enclosure in thermal communication with the evaporator and to slant forward.

ABSTRACT

An ice maker includes an evaporator configured to freeze water into ice as it flows vertically down a freeze plate. A distributor distributes the water along the top of the freeze plate to form ice across the width of the freeze plate as the water flows downward along the freeze plate. The distributor can be integrated into the evaporator. For example, the distributor and evaporator can have a part in common. The distributor can be formed from two pieces that come together to form the freeze plate. The distributor can have various features that aid in providing a desirable distribution of water along the width of the freeze plate. The freeze plate can be mounted in an ice maker enclosure in thermal communication with the evaporator and to slant forward.

ICE MAKER

FIELD

[0001] The present disclosure pertains to an ice maker of the type that includes a distributor that directs water to flow along a freeze plate, which freezes the water into ice.

BACKGROUND

[0002] Ice makers are well-known and in extensive commercial and residential use. One type of ice maker includes an evaporator assembly that comprises a freeze plate which defines a plurality of ice molds in a two-dimensional vertical grid. Refrigerant tubing extends along the back of the freeze plate and forms an evaporator configured to cool the freeze plate. A water distributor is positioned above the freeze plate to direct water onto the freeze plate that freezes into ice in the molds.

SUMMARY

[0003] In one aspect, an ice maker comprises a freeze plate defining a plurality of molds in which the ice maker is configured to form ice. The freeze plate has a front defining open front ends of the molds, a back defining enclosed rear ends of the molds, a top portion and a bottom portion spaced apart along a height, and a first side portion and a second side portion spaced apart along a width. A distributor adjacent the top portion of the freeze plate is configured to direct water imparted through the distributor to flow downward along the front of the freeze plate along the width of the freeze plate. The distributor comprises a first end portion and a second end portion spaced apart along a width of the distributor. A bottom wall extends widthwise from the first end portion to the second end portion and extends generally forward from an upstream end portion to a downstream end portion. The distributor is configured to direct the water imparted therethrough to flow in a generally forward direction from the upstream end portion to the downstream end portion. A weir extends upward from the bottom wall at a location spaced apart between the upstream end portion and the downstream end portion. The weir is configured so that the water flows across the weir as it flows along

the bottom wall from the upstream end portion to the downstream end portion. The bottom wall comprises a ramp surface, immediately upstream of the weir, sloping upward in the generally forward direction.

[0004] In another aspect, an ice maker comprises a freeze plate defining a plurality of molds in which the ice maker is configured to form ice. The freeze plate has a front defining open front ends of the molds, a back defining enclosed rear ends of the molds, a top portion and a bottom portion spaced apart along a height, and a first side portion and a second side portion spaced apart along a width. A distributor adjacent the top portion of the freeze plate is configured to direct water imparted through the distributor to flow downward along the front of the freeze plate along the width of the freeze plate. The distributor comprises a first end portion and a second end portion spaced apart along a width of the distributor. A bottom wall extends widthwise from the first end portion to the second end portion and extends generally forward from an upstream end portion to a downstream end portion. The distributor is configured to direct the water imparted therethrough to flow in a generally forward direction from the upstream end portion to the downstream end portion. The downstream end portion of the bottom wall defines a downwardly curving surface tension curve. The downwardly curving surface tension curve is configured so that surface tension causes the water imparted through the distributor to adhere to the curve and be directed downward by the curve toward the top end portion of the freeze plate.

[0005] In another aspect, an ice maker comprises a freeze plate defining a plurality of molds in which the ice maker is configured to form ice. The freeze plate has a front defining open front ends of the molds, a back defining enclosed rear ends of the molds, a top portion and a bottom portion spaced apart along a height, and a first side portion and a second side portion spaced apart along a width. A distributor adjacent the top portion of the freeze plate is configured to direct water imparted through the distributor to flow downward along the front of the freeze plate along the width of the freeze plate. The distributor comprises a first end portion and a second end portion spaced apart along a width of the distributor. A bottom wall extends widthwise from the first end portion to the second end portion and extends generally forward from an

upstream end portion to a downstream end portion. The distributor is configured to direct the water imparted therethrough to flow in a generally forward direction from the upstream end portion to the downstream end portion. An overhanging front wall has a bottom edge margin spaced apart above the bottom wall adjacent the downstream end portion thereof such that a flow restriction is defined between the bottom wall and the overhanging front wall. The flow restriction comprises a gap extending widthwise between the first end portion and the second end portion of the distributor and is configured to restrict a rate at which water flows through the flow restriction to the downstream end portion of the bottom wall.

[0006] In yet another aspect, an ice maker comprises a freeze plate defining a plurality of molds in which the ice maker is configured to form ice. The freeze plate has a top portion and a bottom portion spaced apart along a height and a first side portion and a second side portion spaced apart along a width. A distributor extends along the width of the freeze plate adjacent the top portion of the freeze plate. The distributor is configured to direct water imparted through the distributor to flow from the top portion of the freeze plate to the bottom portion along the width of the freeze plate. The distributor comprises a first distributor piece and a second distributor piece. The second distributor piece is configured to be releasably coupled to the first distributor piece without separate fasteners to form the distributor.

[0007] In another aspect, an ice maker comprises a freeze plate defining a plurality of molds in which the ice maker is configured to form ice. The freeze plate has a top portion and a bottom portion spaced apart along a height and a first side portion and a second side portion spaced apart along a width. A distributor adjacent the top portion of the freeze plate has a width extending along the width of the freeze plate. The distributor has an inlet and an outlet and defining a distributor flow path extending from the inlet to the outlet. The distributor is configured to direct water imparted through the distributor along the distributor flow path and discharge the water from the outlet such that the water flows from the top portion of the freeze plate to the bottom portion along the width of the freeze plate. The distributor comprises a first distributor piece and a second distributor piece. The second distributor piece is releasably coupled

to the first distributor piece to form the distributor. The first distributor piece comprises a bottom wall defining a groove extending widthwise and the second distributor piece comprising a generally vertical weir defining a plurality of openings spaced apart along the width of the distributor. The weir has a free bottom edge margin received in the groove such that water flowing along the distributor flow path is inhibited from flowing through an interface between the bottom edge margin of the weir and the bottom wall and is directed to flow across the weir through the plurality of openings.

[0008] In another aspect, an ice maker comprises an evaporator assembly comprising a freeze plate defining a plurality of molds in which the evaporator assembly is configured to form pieces of ice. The freeze plate has a front defining open front ends of the molds and a back extending along closed rear ends of the molds. An evaporator housing has a back and defines an enclosed space between the back of the freeze plate and the back of the evaporator housing. Refrigerant tubing is received in the enclosed space. Insulation substantially fills the enclosed space around the refrigerant tubing. A water system is configured to supply water to the freeze plate such that the water forms into ice in the molds. The evaporator housing includes a distributor piece formed from a single piece of monolithic material. The distributor piece is in direct contact with the insulation and has a bottom wall. The water system is configured direct the water to flow along the bottom wall as the water is supplied to the freeze plate.

[0009] In still another aspect, an ice maker comprises an evaporator assembly comprising a freeze plate defining a plurality of molds in which the evaporator assembly is configured to form pieces of ice. The freeze plate has a front defining open front ends of the molds, a back extending along closed rear ends of the molds, a top wall formed from a single piece of monolithic material and defining a top end of at least one of the molds, and at least one stud joined to the top wall and extending upward therefrom. A distributor is configured to distribute water imparted through the distributor over the freeze plate so that the water forms into ice in the molds. The distributor comprises a distributor piece formed from a single piece of monolithic material. The distributor piece comprises a bottom wall defining a portion of a flow path along which the

distributor directs water to flow through the distributor. A nut is tightened onto each stud against the distributor piece to directly mount the distributor on the freeze plate.

[0010] In another aspect, a distributor for receiving water imparted through the distributor and directing the water to flow along a freeze plate of an ice maker so that the water forms into ice on the freeze plate comprises a rear wall adjacent an upstream end of the distributor, a bottom wall extending forward from the rear wall to a front end portion adjacent a downstream end of the distributor, and a tube protruding rearward from the rear wall. The rear wall has an opening immediately above the bottom wall through which the tube fluidly communicates with the distributor. The bottom wall comprises a rear section that slopes downward to the rear wall and a front section that slopes downward to the front end portion.

[0011] In another aspect, an ice maker comprises an enclosure. A freeze plate is received in the enclosure. The freeze plate comprises a back wall and a front opposite the back wall. The freeze plate further comprises a perimeter wall extending forward from the back wall. The perimeter wall comprises a top wall portion, a bottom wall portion, a first side wall portion, and a second side wall portion. The first side wall portion and the second side wall portion define a width of the freeze plate. The freeze plate further comprises a plurality of heightwise divider plates extending from lower ends connected to the bottom wall portion to upper ends connected to the top wall portion and a plurality of widthwise divider plates extending from first ends connected to the first side wall portion to second ends connected to the second side wall portion. The heightwise divider plates and the widthwise divider plates are interconnected to define a plurality of ice molds inboard of the perimeter wall. Each widthwise divider plate defines a plurality of molds immediately above the divider plate and a plurality of molds immediately below the divider plate. Each widthwise divider plate slopes downward and forward away from the back wall of the freeze plate such that included angle between an upper surface of each widthwise divider plate and the back wall is greater than 90° and less than 180° . A distributor is configured to direct water imparted through the distributor to flow downward along the freeze plate along the width of the

freeze plate. The freeze plate is supported in the enclosure so that the back wall of the freeze plate slants forward.

[0012] Other aspects will be in part apparent and in part pointed out hereinafter.

BRIEF DESCRIPTION OF THE DRAWINGS

[0013] FIG. 1 is a schematic illustration of an ice maker;

[0014] FIG. 2 is a perspective of the ice maker supported on an ice bin;

[0015] FIG. 3 is a perspective of a subassembly of the ice maker including a support, an evaporator assembly, a sump, a mounting plate, and a sensor fitting;

[0016] FIG. 4 is an exploded perspective of the subassembly of FIG. 3;

[0017] FIG. 5 is a side elevation of the subassembly of FIG. 3;

[0018] FIG. 6 is a perspective of a freeze plate of the ice maker;

[0019] FIG. 7 is an exploded perspective of the freeze plate;

[0020] FIG. 8 is a vertical cross section of the freeze plate;

[0021] FIG. 9 is a perspective of the evaporator assembly;

[0022] FIG. 10 is a side elevation of the evaporator assembly;

[0023] FIG. 11 is a top plan view of the evaporator assembly;

[0024] FIG. 12 is an exploded perspective of the evaporator assembly;

[0025] FIG. 13 is a rear elevation of the evaporator assembly with back wall removed to reveal serpentine evaporator tubing;

[0026] FIG. 14 is a cross section of the evaporator assembly taken in the plane of line 14-14 of FIG. 11;

[0027] FIG. 15 is a perspective of the evaporator assembly with a top distributor piece removed and showing a bottom distributor piece/top evaporator housing piece and components associated therewith exploded away from the remainder of the evaporator assembly;

[0028] FIG. 16 is an enlarged vertical cross section of the components of the evaporator assembly shown in FIG. 15 taken in a plane that passes through a stud of the freeze plate;

[0029] FIG. 17 is vertical cross section of the evaporator assembly mounted on the support;

[0030] FIG. 18 is a perspective of a distributor of the evaporator assembly;

[0031] FIG. 19 is an exploded perspective of the distributor;

[0032] FIG. 20 is a vertical cross section of the distributor;

[0033] FIG. 20A is an enlarged view of a portion of FIG. 20;

[0034] FIG. 21 is a top perspective of the bottom distributor piece;

[0035] FIG. 22 is a bottom perspective of the bottom distributor piece;

[0036] FIG. 23 is a vertical cross section similar to FIG. 15 except that the plane of the cross section passes through the center of an inlet tube of the bottom distributor piece;

[0037] FIG. 24 is an enlarged perspective of an end portion of the bottom distributor piece;

[0038] FIG. 25 is a perspective of the top distributor piece;

[0039] FIG. 26 is a bottom plan view of the top distributor piece;

[0040] FIG. 27 is a rear elevation of the top distributor piece;

[0041] FIG. 28 is an enlarged perspective of an end portion of the top distributor piece;

[0042] FIG. 29 is a perspective of the evaporator assembly with the top distributor piece spaced apart in front of the bottom distributor piece;

[0043] FIG. 30 is a vertical cross section of the subassembly of FIG. 3 received in a schematically illustrated ice maker enclosure, wherein the plane of the cross section is immediately inboard of a right side wall portion of a vertical side wall of the support as shown in FIG. 3 and wherein the top distributor piece is shown in a removed position outside of the enclosure;

[0044] FIG. 31 is an enlarged horizontal cross section of an end portion of the distributor looking downward on a plane that passes through an elongate tongue of the bottom distributor piece received in an elongate groove of the bottom distributor piece; and

[0045] FIG. 32 is a vertical cross section of the distributor taken in a plane that passes through a segmented weir.

[0046] Corresponding reference characters indicate corresponding parts throughout the drawings.

DETAILED DESCRIPTION

[0047] Referring to FIG. 1, one embodiment of an ice maker is generally indicated at reference number 10. This disclosure details exemplary features of the ice maker 10 that can be used individually or in combination to enhance ice making uniformity, ice harvesting performance, energy efficiency, assembly precision, and/or accessibility for repair or maintenance. One aspect of the present disclosure pertains to an evaporator assembly that includes an evaporator, a freeze plate, and a water distributor. As will be explained in further detail below, in one or more embodiments, the parts of the evaporator assembly are integrated together into a single unit. In certain embodiments, the water distributor includes a configuration of water distribution features that provides uniform water flow along the width of the freeze plate. In an exemplary embodiment, the water distributor is configured to provide ready access to the interior of the distributor for repair or maintenance. In one or more embodiments, the evaporator assembly is configured to mount the freeze plate within the ice maker in an orientation that reduces the time it takes to passively harvest ice using gravity and heat. Other aspects and features of the ice maker 10 will also be described hereinafter. Though this disclosure describes an ice maker that combines a number of different features, it will be understood that other ice makers can use any one or more of the features disclosed herein without departing from the scope of this disclosure.

[0048] The disclosure begins with an overview of the ice maker 10, before providing a detailed description of an exemplary embodiment of an evaporator assembly.

I. Refrigeration System

[0049] Referring FIG. 1, a refrigeration system of the ice maker 10 includes a compressor 12, a heat rejecting heat exchanger 14, a refrigerant expansion device 18 for lowering the temperature and pressure of the refrigerant, an evaporator assembly 20 (broadly, an ice formation device), and a hot gas valve 24. As shown, the heat rejecting heat exchanger 14 may comprise a condenser for condensing compressed refrigerant vapor discharged from the compressor 12. In other embodiments, for example, in refrigeration systems that utilize carbon dioxide refrigerants where the heat of rejection is trans-critical, the heat rejecting heat exchanger is able to reject heat from the refrigerant without condensing the refrigerant. The illustrated evaporator assembly 20 integrates an evaporator 21 (e.g., serpentine refrigerant tubing), a freeze plate 22, and a water distributor 25 into one unit, as will be described in further detail below. Hot gas valve 24 is used, in one or more embodiments, to direct warm refrigerant from the compressor 15 directly to the evaporator 21 to remove or harvest ice cubes from the freeze plate 22 when the ice has reached the desired thickness.

[0050] The refrigerant expansion device 18 can be of any suitable type, including a capillary tube, a thermostatic expansion valve or an electronic expansion valve. In certain embodiments, where the refrigerant expansion device 18 is a thermostatic expansion valve or an electronic expansion valve, the ice maker 10 may also include a temperature sensor 26 placed at the outlet of the evaporator tubing 21 to control the refrigerant expansion device 18. In other embodiments, where the refrigerant expansion device 18 is an electronic expansion valve, the ice maker 10 may also include a pressure sensor (not shown) placed at the outlet of the evaporator tubing 21 to control the refrigerant expansion device 19 as is known in the art. In certain embodiments that utilize a gaseous cooling medium (e.g., air) to provide condenser cooling, a condenser fan 15 may be positioned to blow the gaseous cooling medium across the condenser 14. A form of refrigerant cycles through these components via refrigerant lines 28a, 28b, 28c, 28d.

II. Water System

[0051] Referring still to FIG. 1, a water system of the illustrated ice maker 10 includes a sump assembly 60 that comprises a water reservoir or sump 70, a water pump 62, a water line 63, and a water level sensor 64. The water system of the ice maker 10 further includes a water supply line (not shown) and a water inlet valve (not shown) for filling sump 70 with water from a water source (not shown). The illustrated water system further includes a discharge line 78 and a discharge valve 79 (e.g., purge valve, drain valve) disposed thereon for draining water from the sump 70. The sump 70 may be positioned below the freeze plate 22 to catch water coming off of the freeze plate such that the water may be recirculated by the water pump 62. The water line 63 fluidly connects the water pump 62 to the water distributor 25. During an ice making cycle, the pump 62 is configured to pump water through the water line 63 and through the distributor 25. As will be discussed in greater detail below, the distributor 25 includes water distribution features that distribute the water imparted through the distributor evenly across the front of the freeze plate 22. In an exemplary embodiment, the water line 63 is arranged in such a way that at least some of the water can drain from the distributor through the water line and into the sump when ice is not being made.

[0052] In an exemplary embodiment, the water level sensor 64 comprises a remote air pressure sensor 66. It will be understood, however that any type of water level sensor may be used in the ice maker 10 including, but not limited to, a float sensor, an acoustic sensor, or an electrical continuity sensor. The illustrated water level sensor 64 includes a fitting 68 that is configured to couple the sensor to the sump 70 (see also FIG. 4). The fitting 68 is fluidly connected to a pneumatic tube 69. The pneumatic tube 69 provides fluid communication between the fitting 68 and the air pressure sensor 66. Water in the sump 70 traps air in the fitting 68 and compresses the air by an amount that varies with the level of the water in the sump. Thus, the water level in the sump 70 can be determined using the pressure detected by the air pressure sensor 66. Additional details of exemplary embodiments of a water level sensor comprising a remote air pressure sensor are described in U.S. Patent Application Publication No. 2016/0054043, which is hereby incorporated by reference in its entirety.

[0053] In the illustrated embodiment, the sump assembly 60 further comprises a mounting plate 72 that is configured to operatively support both the water pump 62 and the water level sensor fitting 68 on the sump 70. An exemplary embodiment of a mounting plate 72 is shown in FIG. 4. As described in co-pending U.S. Patent Application No. ###, entitled ICE MAKER, which is hereby incorporated by reference in its entirety, the mounting plate 72 may define an integral sensor mount 74 for operatively mounting sensor fitting 68 on the sump 70 at a sensing position at which the water level sensor 64 is operative to detect the amount of water in the sump. The mounting plate 72 may also define a pump mount 76 for mounting the water pump 62 on the sump 70 for pumping water from the sump through the water line 63 and the distributor 25. Each of the sensor mount 74 and the pump mount 76 may include locking features that facilitate releasably connecting the respective one of the water level sensor 64 and the water pump 62 to the sump 70.

III. Controller

[0054] Referring again to FIG. 1, the ice maker 10 may also include a controller 80. The controller 80 may be located remote from the ice making device 20 and the sump 70 or may comprise one or more onboard processors, in one or more embodiments. The controller 80 may include a processor 82 for controlling the operation of the ice maker 10 including the various components of the refrigeration system and the water system. The processor 82 of the controller 80 may include a non-transitory processor-readable medium storing code representing instructions to cause the processor to perform a process. The processor 82 may be, for example, a commercially available microprocessor, an application-specific integrated circuit (ASIC) or a combination of ASICs, which are designed to achieve one or more specific functions, or enable one or more specific devices or applications. In certain embodiments, the controller 80 may be an analog or digital circuit, or a combination of multiple circuits. The controller 80 may also include one or more memory components (not shown) for storing data in a form retrievable by the controller. The controller 80 can store data in or retrieve data from the one or more memory components.

[0055] In various embodiments, the controller 80 may also comprise input/output (I/O) components (not shown) to communicate with and/or control the various components of ice maker 10. In certain embodiments, for example, the controller 80 may receive inputs such as, for example, one or more indications, signals, messages, commands, data, and/or any other information, from the water level sensor 64, a harvest sensor for determining when ice has been harvested (not shown), an electrical power source (not shown), an ice level sensor (not shown), and/or a variety of sensors and/or switches including, but not limited to, pressure transducers, temperature sensors, acoustic sensors, etc. In various embodiments, based on those inputs for example, the controller 80 may be able to control the compressor 12, the condenser fan 15, the refrigerant expansion device 18, the hot gas valve 24, the water inlet valve (not shown), the discharge valve 79, and/or the water pump 62, for example, by sending, one or more indications, signals, messages, commands, data, and/or any other information to such components.

IV. Enclosure/Ice Bin

[0056] Referring to FIG. 2, one or more components of the ice maker 10 may be stored inside of an enclosure 29 of the ice maker 10 that defines an interior space. For example, portions or all of the refrigeration system and water system of the ice maker 10 described above can be received in the interior space of the enclosure 29. In the illustrated embodiment, the enclosure 29 is mounted on top of an ice storage bin assembly 30. The ice storage bin assembly 30 includes an ice storage bin 31 having an ice hole (not shown) through which ice produced by the ice maker 10 falls. The ice is then stored in a cavity 36 until retrieved. The ice storage bin 31 further includes an opening 38 which provides access to the cavity 36 and the ice stored therein. The cavity 36, ice hole (not shown), and opening 38 are formed by a left wall 33a, a right wall 33b, a front wall 34, a back wall 35 and a bottom wall (not shown). The walls of the ice storage bin 31 may be thermally insulated with various insulating materials including, but not limited to, fiberglass insulation or open- or closed-cell foam comprised, for example, of polystyrene or polyurethane, etc. in order to retard the melting of the ice

stored in the ice storage bin 31. A door 40 can be opened to provide access to the cavity 36.

[0057] The illustrated enclosure 29 is comprised of a cabinet 50 (broadly, a stationary enclosure portion) and a door 52 (broadly, a movable or removable enclosure portion). In FIG. 2, the door 40 of the ice storage bin assembly 30 is raised so that it partially obscures the ice maker door 52. The door 52 is movable with respect to the cabinet 50 (e.g., on a hinge) to selectively provide access to the interior space of the ice maker 10. Thus, a technician may open the door 52 to access the internal components of the ice maker 10 through a doorway (not shown; broadly, an access opening) as required for repair or maintenance. In one or more other embodiments, the door may be opened in other ways, such as by removing the door assembly from the cabinet.

V. Internal Support

[0058] Referring to FIGS. 3-5, the illustrated ice maker 10 comprises a one-piece support 110 that is configured to support several components of the ice maker inside the enclosure 29. For example, the illustrated support 110 is configured to support the sump 70, the mounting plate 72, and the evaporator assembly 20 at very precise positions to limit the possibility of misplacement of these components. The inventors have recognized that ice maker control schemes that use water level as a control input require accurate placement of the water level sensor in the sump. If the position of the water level sensor deviates from the specified position by even a small amount (e.g., millimeters or less), the control scheme can be disrupted. The inventors have further recognized that the aggregated dimensional tolerances of the parts of conventional assemblies for mounting internal ice maker components can lead to misplacement. Still further, the inventors have recognized that precisely positioning an evaporator assembly in an ice maker can enhance gravity-driven ice making and ice-harvesting performance.

[0059] In the illustrated embodiment, the support 110 includes a base 112 and a vertical support wall 114. The illustrated vertical support wall comprises a first side wall portion 116, a second side wall portion 118, and a back wall portion 120 extending widthwise between the first and second side wall portions. A large opening 122 extends

widthwise between the front end margins of the side wall portions 116, 118. When the ice maker 10 is fully assembled, this opening 122 is located adjacent a front doorway 268 (FIG. 30) of the enclosure 29 such that a technician can access the components supported on the vertical wall through the opening when the door 52 is open.

[0060] Each side wall portion 116, 118 includes an integral evaporator mount 124 (broadly, a freeze plate mount). The evaporator mounts 124 are configured to support the evaporator assembly 20 at an operative position in the ice maker 10. Each side wall portion 116, 118 further comprises an integral mounting plate mount 126 that is spaced apart below the evaporator mount 124. The mounting plate mount 126 is configured to support the mounting plate 72 so that the mounting plate can mount the water level sensor fitting 68 and the pump 62 at operative positions in the ice maker 10. An integral sump mount 128 for attaching the sump 70 to the ice maker is spaced apart below the mounting plate mount 126 of each side wall portion 116, 118. In FIGS. 3-5, only the mounts 124, 126, 128 defined by the right side wall portion 116 are shown, but it will be understood that the left side wall portion 118 has substantially identical, mirror-image mounts in the illustrated embodiment.

[0061] At least one of the side wall portions 116, 118 that defines the mounts 124, 126, 128 is formed from a single piece of monolithic material. For example, in one or more embodiments, the entire vertical support wall 114 is formed from a single monolithic piece of material. In the illustrated embodiment, the entire support 110, including the base 112 and the vertical support wall 114, is formed from a single piece of monolithic material. In one or more embodiments, the support 110 is a single molded piece. In the illustrated embodiment, the monolithic support 110 is formed by compression molding. Forming the support 110 from a single piece eliminates the stacking of tolerances that occurs in a multi-part support assembly and thereby increases the accuracy of the placement of the parts that are mounted on the support.

[0062] The evaporator mounts 124 are configured to mount the evaporator assembly 20 on the vertical support wall 114 in the enclosure 29 such that the freeze plate 22 slants forward. To accomplish this, each evaporator mount 124 in the illustrated embodiment comprises a lower connection point 130 and an upper

connection point 132 forwardly spaced from the lower connection point. As shown in FIG. 5, the connection points 130, 132 are spaced apart along an imaginary line IL1 that is oriented at a forwardly slanted angle α with respect to a plane BP the back wall portion 120 of the vertical support wall 114. In use, the ice maker 10 is positioned so that the plane BP of the back wall portion 120 is substantially parallel to a plumb vertical axis VA. As such, the imaginary line IL1 slants forward with respect to the plumb vertical axis VA at the angle α .

[0063] In the illustrated embodiment, each of the upper and lower connection points 130, 132 comprises a screw hole. In use, the evaporator 20 is positioned between the side wall portions 116, 118, and a screw (not shown) is placed through each screw hole into a corresponding pre-formed screw hole associated with the evaporator assembly 20. As explained below, the pre-formed evaporator screw-holes are arranged so that, when they are aligned with the evaporator mount screw holes 130, 132, the freeze plate 22 slants forward. It will be appreciated that an integral evaporator mount can include other types of connection points besides screw holes in one or more embodiments. For example, it is expressly contemplated that one or both of the screw holes 130, 132 could be replaced by an integrally formed stud or other structure that can be used to register and attach a freeze plate to the support at the proper position.

[0064] Each mounting plate mount 126 comprises a pair of generally horizontally spaced tapered screw holes 134 (broadly, connection points). Similarly, each sump mount 128 comprises a pair of generally horizontally spaced mounting holes 136 (broadly, connection points). Again, the holes 134, 136 of the mounting plate mount 126 and the sump mount 128 could be replaced with other types of integral connection points in one or more embodiments.

[0065] As shown in FIG. 4, in one or more embodiments, the sump 70 is generally sized and arranged for being received in the space between the side wall portions 116, 118 of the vertical support wall 114. Each of a first end portion and a second end portion of the sump 70 that are spaced apart widthwise includes a pair of projections 138 at spaced apart locations. The projections 138 on each end portion of the sump 70 are configured to be received in the pair of mounting holes 136 defined by a respective one

of the sump mounts 128. The projections 138, by being received in the mounting holes 136, position the sump 70 at a precisely specified position along the height of the support 110. In addition, a screw (not shown) is inserted through each mounting hole 136 and threaded into each projection 138 to fasten the sump 70 onto the support 110 at the specified position.

[0066] Like the sump 70, the illustrated mounting plate 72 comprises a first end portion and a second end portion that are spaced apart widthwise. Each end portion of the mounting plate 114 defines a pair pre-formed screw holes that are configured to be aligned with the screw holes 134 of the corresponding mount 126 of the support 110. Screws (broadly, mechanical fasteners; not shown) pass through the screw holes 134 and thread into the holes that are pre-formed in the mounting plate 72 to connect the mounting plate to the support 110 at a precisely specified position along the height of the support. In one or more embodiments, countersunk screws (e.g., screws with tapered heads) are used to connect the mounting plate 72 to the support 110. The countersunk screws self-center in the tapered screw holes 134.

[0067] It can be seen that the one-piece support 110 with integral mounts 124, 126, 128 can be used to ensure that the evaporator assembly 20, the mounting plate 72, and the sump 70 are supported in the ice maker 10 at the specified position. The support 110 can thereby position the freeze plate 22 to optimally balance desired performance characteristics, such as water distribution during ice making and ease/speed of ice-harvesting. Further, the support 110 can position the mounting plate 72 with respect to the sump 70 so that the pressure sensor fitting 68 mounted in the sensor mount 74 is precisely positioned with respect to the sump for accurately detecting the water level using the sensor 64. Likewise, the support 110 positions the mounting plate 72 with respect to the sump 70 so that the pump 62 is precisely positioned for pumping water from the sump 70 through the ice maker 10 when the pump is mounted on the pump mount 76.

VI. Freeze Plate

[0068] Referring to FIGS. 6-8, an exemplary embodiment of the freeze plate 22 will now be described, before turning to other components of the evaporator assembly 20 that attach the freeze plate to the support 110. The freeze plate 22 defines a plurality of molds 150 in which the ice maker 10 is configured to form ice. The freeze plate 22 has a front defining open front ends of the molds 150, a back defining enclosed rear ends of the molds, a top portion and a bottom portion spaced apart along a height HF, and a right side portion (broadly, a first side portion) and a left side portion (broadly, a second side portion) spaced apart along a width WF.

[0069] Throughout this disclosure, when the terms "front," "back," "rear," "forward," "rearward," and the like are used in reference to any part of the evaporator assembly 20, the relative positions of the open front ends and enclosed rear ends of the freeze plate molds 150 provide a spatial frame of reference. For instance, the front of the freeze plate 22 that defines the open front ends of the molds 150 is spaced apart from the rear of the freeze plate in a forward direction FD (FIG. 8), and the back of the freeze plate that extends along the enclosed rear ends of the molds is spaced apart from the front of the freeze plate in a rearward direction RD.

[0070] In the illustrated embodiment, the freeze plate 22 comprises a pan 152 having a back wall 154 that defines the back of the freeze plate. Suitably, the pan 152 is formed from thermally conductive material such as copper, optionally having one or more surfaces coated with a food-safe material. As is known in the art, the evaporator tubing 21 is thermally coupled to the back wall 154 of the freeze plate 22 for cooling the freeze plate during ice making cycles and warming the freeze plate during harvest cycles.

[0071] The pan 152 further comprises a perimeter wall 156 that extends forward from the back wall 154. The perimeter wall 156 includes a top wall portion, a bottom wall portion, a right side wall portion (broadly, a first side wall portion), and a left side wall portion (broadly, a second side wall portion). The side wall portions of the perimeter wall 156 define the opposite sides of the freeze plate 22, and the top and bottom wall portions of the perimeter wall define the top and bottom ends of the freeze plate. The perimeter wall 156 could be formed from one or more discrete pieces that are

joined to the back wall 154 or the pan 152, or the entire pan could be formed from a single monolithic piece of material in one or more embodiments. Suitably, the perimeter wall 156 is sealed to the back wall 154 so that water flowing down the freeze plate 22 does not leak through the back of the freeze plate.

[0072] A plurality of heightwise and widthwise divider plates 160, 162 are secured to the pan to form a lattice of the ice cube molds 150. In an exemplary embodiment, each heightwise divider plate 160 and each widthwise divider plate 162 is formed from a single piece of monolithic material. Each heightwise divider plate 160 has a right lateral side surface (broadly, a first lateral side surface) and a left lateral side surface (broadly a second lateral side surface) oriented parallel to the right lateral side surface. Each widthwise divider plate 162 has a bottom surface and a top surface oriented parallel to the bottom surface. The heightwise divider plates 162 extend from lower ends that are sealingly connected to the bottom wall portion of the perimeter wall 156 to upper ends that are sealingly connected to the top wall portion of the perimeter wall. The plurality of widthwise divider plates 160 similarly extend from first ends sealingly connected to the right side wall portion of the perimeter wall 156 to second ends sealingly connected to the left side wall portion of the perimeter wall.

[0073] Generally, the heightwise divider plates 160 and the widthwise divider plates 162 are interconnected in such a way as to define a plurality of ice molds 150 within the perimeter wall 156. For example, in the illustrated embodiment, each of the heightwise divider plates 160 has a plurality of vertically-spaced, forwardly-opening slots 164; each of the widthwise divider plates has a plurality of horizontally-spaced, rearwardly-opening slots 166; and the heightwise and widthwise divider plates are interlocked at the slots 164, 166 to form the lattice. Suitably, each widthwise divider plate 162 defines a plurality of the molds 150 (e.g., at least three molds) immediately above the divider plate and a plurality of the molds (e.g., at least three molds) immediately below the divider plate. Each heightwise divider plate 160 likewise defines a plurality of the molds 150 (e.g., at least three molds) immediately to one lateral side of the divider plate and a plurality of the molds (e.g., at least three molds) immediately to the opposite lateral side of the divider plate.

[0074] Each of the divider plates 160, 162 has a front edge and a back edge. The back edges may suitably be sealingly joined to the back wall 154 of the freeze plate pan 152. When the freeze plate 22 is assembled, the front edges of some or all of the divider plates 160, 162 (e.g., at least the widthwise divider plates) lie substantially on a front plane FP (FIG. 8) of the freeze plate 22. In one or more embodiments, the front plane FP is parallel to the back wall 154.

[0075] A plurality of the ice molds 150 formed in the freeze plate 22 are interior ice molds having perimeters defined substantially entirely by the heightwise and widthwise divider plates 160, 162. Others of the molds 150 are perimeter molds having portions of their perimeters formed by the perimeter wall 156 of the freeze plate pan 152. Each interior ice mold 150 has an upper end defined substantially entirely by the bottom surface of one of the widthwise divider plates 162 and a lower end defined substantially entirely by the top surface of an adjacent one of the widthwise divider plates. In addition, each interior mold 150 has a left lateral side defined substantially entirely by a right lateral side surface of a heightwise divider plate 162 and a right lateral side defined substantially entirely by a left lateral side surface of the adjacent heightwise divider plate.

[0076] As shown in FIG. 8, each widthwise divider plate 162 slopes downward and forward from the back wall 154 of the freeze plate 22 such that an included angle β between an upper surface of each widthwise divider plate and the back wall is greater than 90° . In one or more embodiments, the included angle β is at least 100° and less than 180° . It can be seen that the included angle between the top surface of each widthwise divider plate 16 and the front plane FP is substantially equal to the included angle β . Further, it can be seen that the included angle between the bottom surface of each horizontal divider plate 162 and the back wall 154 (and also the included angle between the bottom surface of each horizontal divider plate 162 and the front plane FP) is substantially equal to 180° minus β . The top and bottom portions of the perimeter wall 156 of the pan are oriented substantially parallel to the widthwise divider plates 162 in one or more embodiments.

[0077] A series of threaded studs 168 extend outward from the perimeter wall 156 at spaced apart locations around the perimeter of the freeze plate 22. As will be explained in further detail below, the threaded studs 168 are used to secure the freeze plate 22 to an evaporator housing 170 that attaches the evaporator assembly 20 to the support 110. The studs 168 are suitably shaped and arranged to connect the freeze plate 22 to the evaporator housing 170, and further to the support 110, such that the back wall 154 and front plane FP of the freeze plate slants forward when the freeze plate is installed in the ice maker 10.

VII. Evaporator Housing

[0078] Referring to FIGS. 9-14, the evaporator housing 170 will now be described in greater detail. In general, the evaporator housing 170 is configured to support the evaporator tubing 21 and the freeze plate 22. As will be explained in further detail below, the water distributor 25 is integrated directly into (i.e., forms a part of) the evaporator housing 170. The evaporator housing 170 comprises a frame including a bottom piece 172, a top piece 174, and first and second side pieces 176 that together extend around the perimeter of the freeze plate 22. Each of the bottom piece 172, the top piece 174, and the opposite side pieces 176 is formed from a single, monolithic piece of material (e.g., molded plastic), in one or more embodiments. The inner surfaces of the bottom piece 172, the top piece 174, and the opposite side pieces 176 may include a gasket (not shown) to aid in watertight sealing of the evaporator housing. The top piece 174 of the evaporator housing 170 forms a bottom piece (broadly, a first piece) of the two-piece distributor 25 in the illustrated embodiment.

[0079] A back wall 178 is supported on the assembled frame pieces 172, 174, 176, 178 in spaced apart relationship with the back wall 154 of the freeze plate 22. As shown in FIG. 14, the evaporator housing 170 defines an enclosed space 180 between the back wall 154 of the freeze plate 22 and the back wall 178 of the housing. As explained in U.S. Patent Application Publication No. 2018/0142932, which is hereby incorporated by reference in its entirety, in one or more embodiments, two discrete layers 182, 184 of insulation fills enclosed space 176 and thoroughly insulates the evaporator tubing 21.

[0080] The bottom piece 172, the top piece 174, the opposite side pieces 176, and/or the back wall 178 may have features that facilitate assembling them together to form the evaporator housing 170 in a variety of ways, including snap-fit features, bolts and nuts, etc. For example, each of the frame pieces 172, 174, 176 comprises stud openings 186 that are arranged to receive the studs 168 on the corresponding wall portion of the perimeter wall 156 of the freeze plate 22. Some of the stud holes 186 are visible in FIG. 12. In one or more embodiments, the back wall 178 is joined to the assembled frame pieces 172, 174, 176 by ultrasonic welding.

[0081] Referring to FIGS. 15 and 16, one example of how the housing pieces 172, 174, 176 attach to the freeze plate 72 is shown in greater detail. Specifically, the top housing piece 174 is shown, but it will be understood that the other housing pieces may attach to the freeze plate in a like manner. The top piece 174 includes a front section that defines the stud openings 186. In the illustrated embodiment, each stud opening 186 comprises a countersunk screw recess that includes an annular shoulder 192. The top piece 174 is positioned atop the freeze plate 22 such that one stud 168 is received in each of the openings 186. In the illustrated embodiment, a gasket 194 is located between the top of the freeze plate 22 and the bottom of the top piece 174 to seal the interface between the two parts. Nuts 196 are tightened onto each of the studs 168 to attach the top piece 174 to the freeze plate 22. Further, because the housing top piece 174 forms the bottom piece of the distributor 25, tightening the nuts 196 onto the studs also attaches the distributor directly to the freeze plate in the illustrated embodiment. Each nut 196 is tightened against the shoulder 192 of a respective countersunk recesses 186 (broadly, the nuts are tightened directly against the top housing piece 170 or bottom distributor piece). In the illustrated embodiment, caps 198 are placed over the tops of the countersunk recesses 186. Suitably, the tops of the caps 198 are substantially flush with the surface of the piece 174 to present a smooth surface to water flowing through the distributor 25.

VIII. Mounting of Evaporator Assembly so that Freeze Plate Slants Forward

[0082] Referring again to FIGS. 9 and 10, each of the side pieces 176 of the evaporator housing 170 include pre-formed lower and upper screw openings 200, 202 at vertically spaced apart locations. The upper and lower screw openings 200, 202 are configured to be positioned in registration with the screw openings 130, 132 of a respective side wall portion 116, 118 of the support 110. When each side piece 176 is secured to the freeze plate 22 via the studs 168, the screw openings 200, 202 are spaced apart along an imaginary line IL2 oriented substantially parallel to the back wall 154 and the front plane FP of the freeze plate 22. Referring to FIG. 17, when screws (not shown) secure the evaporator assembly 20 to the support 110 via the aligned lower screw openings 130, 200 and the aligned upper screw openings 132, 202, the imaginary line IL2 of the evaporator housing 170 is aligned with the forwardly slanted imaginary line IL1 of the support.

[0083] Thus, the screw openings 130, 132, 200, 202 position the freeze plate 22 on the support 110 so that the back wall 154 and front plane FP are oriented at the forwardly slanted angle α with respect to both the plumb vertical axis VA and the back plane BP of the support 110. In one or more embodiments, the included angle α between the back wall 154/front plane FP and the plumb vertical axis VA/back plane BP is at least about 1.5° . For example, in an exemplary embodiment, the included angle α is about 2.0° . Accordingly, the illustrated ice maker 10 is configured to mount the freeze plate 22 in the enclosure 29 so that the back wall 154 slants forward. It will be appreciated that, though the one-piece support 110 and the side pieces 176 of the evaporator housing 170 are used to mount the freeze plate 22 in the slanted orientation in the illustrated embodiment, other ways of mounting a freeze plate may be used in other embodiments.

[0084] It is believed that conventional wisdom in the field of ice makers held that orienting a freeze plate with grid-type divider plates so that the back wall of the freeze plate slants forward would adversely affect the water distribution performance of the ice maker. However, because of the high-quality flow distribution produced by the water distributor 25—achieved, for example, using one or more of the water distribution

features described below—water is effectively distributed to the molds 150 even though the freeze plate 22 is mounted with the back wall 154 slanted forward. Further, the slanted freeze plate 22 enables the ice maker 10 to harvest ice quickly, using gravitational forces. In one or more embodiments, the ice maker 10 is configured to execute a harvest cycle by which ice is released from the molds 150 of the freeze plate 22, wherein substantially the only forces imparted on the ice during the harvest cycle are gravitational forces. For example, the harvest cycle is executed by actuating the hot gas valve 24 to redirect hot refrigerant gas back to the evaporator tubing 21, thereby warming the freeze plate 22. The ice in the molds 150 begins to melt and slides forward down the sloping widthwise divider plates 162, off the freeze plate, and into the ice bin 30. In a harvest cycle in which substantially the only forces imparted on the ice are gravitational forces, no mechanical actuators, pressurized air jets, or the like are used to forcibly push the ice off of the freeze plate 22. Rather, the slightly melted ice falls by gravity off of the freeze plate 22.

IX. Water Distributor

[0085] Referring now to FIGS. 9 and 18-19, an exemplary embodiment of the distributor 25 will now be described. As explained above, the distributor comprises a bottom piece 174 that forms a top piece of the evaporator housing 170. The distributor 25 further comprises a top piece 210 that releasably attaches to the bottom piece 174 to form the distributor. While the illustrated distributor 25 comprises a two-piece distributor that is integrated directly into the evaporator housing 170, it will be understood that distributors can be formed from other numbers of pieces and attach to the ice maker in other ways in other embodiments. As shown in FIG. 9, the distributor 25 is mounted on the evaporator assembly 20 adjacent the top of the freeze plate 22 and has a width WD that extends generally along the width WF of the freeze plate 22. The distributor 25 extends widthwise from a right end portion (broadly, first end portion) adjacent the right side of the freeze plate 22 to a left end portion (broadly, a second end portion) adjacent the left side of the freeze plate.

[0086] The distributor 25 has a rear, upstream end portion defining an inlet 212 and a front, downstream end portion defining an outlet 214. The downstream end portion extends widthwise adjacent the top-front corner of the freeze plate 22, and the upstream end portion extends widthwise at location spaced apart rearward from the downstream end portion. In the illustrated embodiment, the inlet 212 formed by an opening at the upstream end portion of the distributor, and the outlet 214 is defined by an exposed lower front edge of the distributor 25. In use, this edge is arranged so that water flows off of the edge onto the top portion of the freeze plate 22. It is contemplated that the inlet and/or outlet could have other configurations in other embodiments.

[0087] As shown in FIG. 20, the distributor 25 defines a distributor flow path FP extending generally forward from the inlet 212 to the outlet 214. The distributor 25 is generally configured to direct water imparted through the distributor along the distributor flow path FP to discharge the water from the outlet 214 such that the water flows from the top portion of the freeze plate 22 to the bottom portion generally uniformly along the width WF of the freeze plate. As will be explained in further detail below, the distributor 25 includes a number of water distribution features that direct the water flowing along the flow path FP to be distributed generally uniformly along substantially the entire width of the distributor.

[0088] Each of the bottom and top pieces 174, 210 will now be described in detail before describing how the distributor 25 is assembled and used to distribute water over the freeze plate 22.

IX.A. Distributor Bottom Piece

[0089] Referring to FIGS. 21-22, the bottom distributor piece 174 has a right end wall 216 (broadly, a first end wall) at the right end portion of the distributor 25, a left end wall 218 (broadly, a second end wall) at the left end portion of the distributor, and a bottom wall 220 extending widthwise from the right end wall to the left end wall. Referring to FIG. 23, as explained above, the bottom distributor piece 174 is directly attached to the freeze plate 22. Further, in the illustrated embodiment, the bottom distributor piece 174 is in direct contact with the insulation 184 that fills the enclosed

space 180 between the back wall 154 of the freeze plate and the back wall 178 of the evaporator housing 170. A front section 222 of the bottom wall 220 is located generally above the freeze plate 22 to mount the distributor piece 174 on the freeze plate as described above, and a rear section 224 of the bottom wall is located generally above the enclosed space 180 to directly contact the insulation 184.

[0090] In the illustrated embodiment, the rear section 224 includes a rear leg 226 extending downward at a rear end portion of the bottom wall and a front leg 228 extending downward at a location forwardly spaced from the rear leg. Each of the front and rear legs 226, 228 extends widthwise between the right and left end walls 216, 218 of the bottom distributor piece 174. The rear leg 226 is sealingly engaged with the back wall 178 of the evaporator housing 170 (e.g., the rear leg is ultrasonically welded to the back wall). The bottom wall 220 defines a lower recess 230 located between the front and rear legs 226, 228. The lower recess 230 extends widthwise between the right and left end walls 216, 218 and forms the top of the enclosed space 180. Thus a portion of the insulation 184 is received in the recess 230 and directly contacts the bottom distributor piece along three sides defining the recess. This is thought to thermal losses between the distributor and evaporator.

[0091] Referring to FIG. 24, each end wall 216, 218 in the illustrated embodiment comprises an elongate tongue 232 formed along an inner surface. Only the left end wall 218 is shown in FIG. 24, but it will be understood that the right end wall 216 has a substantially identical, mirror image tongue 232. The elongate tongues 232 extend longitudinally in parallel, generally front-to-back directions. The elongate tongues 232 are generally configured to form male fittings that releasably couple the bottom distributor piece 174 to the top distributor piece 210 without the use of separate fasteners. Each elongate tongue 232 has a front end portion and a rear end portion spaced apart longitudinally from the front end portion. Between the front end portion and the rear end portion, each tongue comprises a slight depression 234.

[0092] Referring to FIGS. 19 and 20, the bottom wall 220 extends generally forward from a rear, upstream end portion to a front, downstream end portion. A rear wall 236 extends upward from the upstream end portion of the bottom wall 220. The

inlet opening 212 is formed in the rear wall 236. In the illustrated embodiment, the inlet opening 236 is generally centered on the rear wall 236 at a spaced apart location between the end walls 216, 218. Thus, broadly speaking, the inlet opening 212 through which water is directed into the interior of the distributor 25 is spaced apart widthwise between the first end portion and the second end portion of the distributor. During use, the distributor 25 is configured to direct the water to flow from the inlet opening 212 along the bottom wall 220 in a generally forward direction FD from the upstream end portion of the bottom wall to the downstream end portion.

[0093]An integral inlet tube 238 protrudes rearward from the rear wall 236 and fluidly communicates through the rear wall via the inlet opening 212. The tube 238 slopes downward and rearward as it extends away from the rear wall 236. The inlet tube 238 is configured to be coupled to the ice maker's water line 63 (FIG. 1). Accordingly, when ice is being made, the pump 62 pumps water from the sump 70 through the water line 63 and into the distributor 25 via the integral inlet tube 238. When ice is not being made, residual water in the distributor 25 can drain through the inlet tube 238, down the water line 63, and into the sump 70.

[0094]In the illustrated embodiment, the rear section 224 of the bottom wall 220 slopes downward and rearward along substantially the entire width of the bottom wall. Conversely, the front section 222 of the bottom wall 220 slopes downward and forward along substantially the entire width. The front section 222 thus forms a runoff section along which water flows forward and downward toward the downstream end portion of the bottom wall 220. Between the sloping rear section 224 and the sloping front section 222 the bottom wall comprises a middle section that includes a widthwise groove 240. The widthwise groove is configured to sealingly receive a portion of the top distributor piece 210 when the top distributor piece is coupled to the bottom distributor piece 174. In one or more embodiments, the groove 240 is convex in the widthwise direction (see FIG. 33). An apex of the bottom wall 220 is located immediately upstream of the widthwise groove 240. The rear section 224 of the bottom wall slopes downward from the apex to the rear wall 236. As shown in FIG. 23, the rear section 224 of the bottom wall 220 includes a ramp surface 242 that defines the apex and a rearmost (or

upstream-most) surface portion 244 (broadly, an upstream segment). The ramp surface 242 and the rearmost surface portion 244 extend widthwise from the right end wall 216 to the left end wall 218. The ramp surface 242 slopes upward in the generally forward direction and downward in the generally rearward direction. The rearmost surface portion 244 slopes upward in the generally forward direction more gradually than the ramp surface 242. The rearmost surface portion 244 is oriented at an angle of less than 180° with respect to the ramp surface 242 such that the rearmost surface portion slopes downward in the generally rearward direction at a more gradual angle than the ramp surface in the illustrated embodiment.

[0095] The bottom wall 220 is configured to passively drain water from the distributor 25 when the ice maker 10 stops making ice. Whenever the ice maker 10 stops making ice, residual water in the front portion of the distributor 25 flows forward along the sloping front section 222 (runoff section) of the bottom wall 220 and drains off of the outlet 214 onto the freeze plate 22. Similarly, residual water in the rear portion of the distributor 25 flows rearward along the sloping rear section 224 and drains through the inlet opening 212 into the inlet tube 238. The water directed forward flows downward along freeze plate 22 and then flows off the freeze plate into the sump 70. The water directed rearward flows downward through the water line 63 into the sump 70. Thus, the distributor 25 is configured to direct substantially all residual water into the sump 70 when the ice maker 10 is not making ice. Further, in one or more embodiments, the sump 70 is configured to drain substantially all of the water received therein through the discharge line 78 when the ice maker 10 is not in use. As can be seen, the shape of the bottom wall 220 of the distributor 25 facilitates total passive draining of the ice maker 10 when ice is not being made.

[0096] Referring to FIG. 21, a lateral diverter wall 246 extends upward from the bottom wall 220 along the rearmost surface portion 244. The lateral diverter wall 246 is spaced apart between the rear wall 236 and the ramp surface 242. The lateral diverter wall 246 extends upward from the bottom wall 220 to a top edge that is spaced apart below the top of the assembled distributor 25 (see FIG. 20). The diverter wall 246 extends widthwise from a right end portion (broadly, a first end portion) spaced apart

from the right end wall 216 to a left end portion (broadly, a second end portion) spaced apart from the left end wall 216. The lateral diverter wall 246 is positioned in front of the inlet opening 214. As water flows into the distributor 25 through the inlet opening, the lateral diverter wall 246 is configured to divert at least some of the water laterally outward, forcing the water to flow around the left and right ends of the lateral diverter wall.

[0097] Referring to FIGS. 20A and 23, the downstream end portion of the bottom wall 220 defines a downwardly curving surface tension curve 247 that extends widthwise from the right end wall 216 to the left end wall 218. The downwardly curving surface tension curve 247 is configured so that surface tension causes the water flowing along the bottom wall 220 to adhere to the curve and be directed downward by the curve toward the top end portion of the freeze plate 22. In one or more embodiments, the surface tension curve 270 is at least partially defined by a radius R of at least 1 mm. In certain embodiments, the surface tension curve 270 is defined by a radius of less than 10 mm. In one or more embodiments, the surface tension curve 270 is defined by a radius in an inclusive range of from 1 mm to 3 mm. In an exemplary embodiment, the surface tension curve 270 is defined by a radius of 1.5 mm.

[0098] The bottom wall 220 further comprises a waterfall surface 249 extending generally downward from the surface tension curve 274 to a bottom edge that defines the outlet 214 of the distributor 212. The waterfall surface 249 extends widthwise from the right end wall 216 to the left end wall 218. The waterfall surface 249 generally is configured so that surface tension causes the water imparted through the distributor 25 to adhere to the waterfall surface and flow downward along the waterfall surface onto the top end portion of the freeze plate 22. In one or more embodiments, the waterfall surface 249 slants forward in the ice maker 10 such that the waterfall surface is oriented generally parallel to the back wall 254 (and front plane FP) of the forwardly slanting freeze plate 22.

IX.B. Top Distributor Piece

[0099] Referring to FIGS. 25-27, the top distributor piece 210 has a right end wall 250 (broadly, a first end wall) at the right end portion of the distributor 25 and a left end wall 252 (broadly, a second end wall) at the left end portion of the distributor. The width of the top distributor piece 210 is slightly less than the width of the bottom distributor piece 174 such that the top distributor piece is configured to nest between the end walls 216, 218 of the bottom distributor piece.

[00100] Referring to FIG. 28, each end wall 250, 252 in the illustrated embodiment comprises an elongate groove 254 along an outer surface. Only the left end wall 252 is shown in FIG. 28, but it will be understood that the right end wall 250 has a substantially identical, mirror image groove 254. Generally, the elongate grooves 254 are configured to form complementary female fittings that mate with the male fittings formed by the elongate tongues 232 to releasably couple the top distributor piece 210 to the bottom distributor piece 174 without the use of separate fasteners. The elongate grooves 254 are generally parallel, extending longitudinally in a generally front-to back direction. The rear end portion of each elongate groove 254 defines a flared opening through which a respective elongate tongue 174 can pass into the groove. Each end wall further defines a protuberance 256 that protrudes into the groove at a location spaced apart between the front and rear ends of the groove 254.

[00101] Referring again to FIGS. 25-27, the top distributor piece 210 comprises a top wall 258 that extends widthwise from the right end wall 250 to the left end wall 252. The top wall 258 extends generally forward from a rear edge margin. A front wall 260 extends generally downward from a front end portion of the top wall to a free bottom edge margin. Two handle portions 262 extend forward from the front wall 260 in the illustrated embodiment.

[00102] As shown in FIGS. 26-27, the top distributor piece 210 further comprises a weir 264 that extends downward from the top wall 258 at a location spaced apart between the rear edge margin and the front wall 260. The weir 264 extends widthwise from the right end wall 250 to the left end wall 252 and has a free bottom edge margin that is configured to be received in the widthwise groove 240 of the bottom

distributor piece 174. As shown in FIG. 27, the bottom edge margin of the weir 264 is convex in the widthwise direction. The weir 264 defines a plurality of openings 266 at spaced apart locations along the width WD of the distributor 25. A bottom portion of the weir 264 below the openings 266 is configured to hold back water until the water level reaches the bottom of the openings. The openings 266 are configured so that water is passable through the openings as it is imparted through the distributor 25. Adjacent openings are separated by portions of the weir 264, such that the weir is configured to form a segmented weir that allows water to cross at spaced apart segments along the width WD of the distributor 25 (through the openings).

IX.C. Assembly of Two-Piece Distributor

[00103] Referring to FIGS. 29-30, to assemble the distributor 25, the top distributor piece 210 is aligned in the widthwise direction with the space between the end walls 216, 218 of the bottom distributor piece 174. Then the top piece 210 is moved in the rearward direction RD into the space between the rear walls 216, 218, such that the elongate tongues 232 of the bottom piece are slidably received in the elongate grooves 254 of the top piece.

[00104] As seen in FIG. 30, the evaporator assembly 20 is suitably arranged in the interior of the ice maker enclosure 29 so that the top piece 210 can be installed/removed through an access opening 268 such as the doorway of the cabinet 50. In the illustrated embodiment, the doorway 268 is spaced apart from the front of the evaporator assembly 20 in the forward direction FD. Further, the front opening 122 in the support 110 is located between the front of the evaporator assembly 20 and the doorway 268. Thus, the top distributor piece 210 can be installed by moving the piece through the doorway 268 and the opening 122 in the rearward direction RD. The top distributor piece 210 is removed by moving the piece through the opening 122 and the doorway 268 in the forward direction FD.

[00105] Each tongue 232 is configured to be slidably received in the respective groove 254 as the top distributor piece 210 moves toward the bottom distributor piece 174 in the rearward direction RD. That is, the parallel longitudinal orientations of the

tongues 232 and grooves 254 facilitate coupling the top distributor piece 210 to the bottom distributor piece 174 simply by moving the top distributor piece in the rearward direction RD. Thus, the complementary fittings formed by the tongues 232 and grooves 254 are configured to be engaged by movement of the top distributor piece 210 inward into the interior of the enclosure 29 from the doorway 268. Further, the complementary fittings 232, 254 are configured to be disengaged simply by urging the top distributor piece 210 away from the bottom distributor piece 174 in the forward direction FD, toward the doorway 268. When maintenance or repair of the distributor 25 is required, a technician merely opens the door 52 (FIG. 2), grips the handles 262, and pulls the top distributor piece 210 outward in the forward direction FD through the doorway 268. To replace the top distributor piece 210, the technician inserts the piece through the doorway 268, aligns the open ends of the grooves 254 with the tongues 232, and pushes the top piece rearward. The tongues 232 are then slidably received in the grooves 254, and the complementary fittings thereby couple the top distributor piece 210 to the bottom distributor piece 174 without using any additional fasters such as screws or rivets.

[00106] Though the illustrated embodiment uses the bottom distributor piece's elongate tongues 232 as male fittings and the top distributor piece's elongate grooves 254 as complementary female fittings, other forms or arrangements of complementary integral fittings can be utilized to releasably couple one distributor piece to another in one or more embodiments. For example, it is expressly contemplated that in certain embodiments one or more male fittings could be formed on the top distributor piece and one or more complementary female fittings could be formed on the bottom distributor piece. It is further contemplated that the fittings could be formed at alternative or additional locations other than the end portions of the distributor.

[00107] Referring to FIG. 31, each pair of complementary fittings comprises a detent configured to keep the respective tongue 232 at a coupling position along the respective groove 254. More specifically, the protuberances 256 formed in the grooves 254 are configured to be received in the depressions 234 of the tongues 232 to provide a detent when the complementary fittings are at the coupling position. The detent resists

inadvertent removal of the top distributor piece 210 from the bottom distributor piece 174 and provides a tactile snap when the tongue 232 slides along the groove 254 to the coupling position. It will be appreciated that the detent can be formed in other ways in one or more embodiments.

[00108] Referring to FIGS. 20 and 32, as the top distributor piece 210 slides in the rearward direction RD to couple the distributor pieces together, the bottom edge margin of the weir 264 slides along the downstream (front) section 222 of the bottom wall 220. When the top distributor piece 210 reaches the coupling position, the bottom edge margin of the weir 264 is received in the groove 240. In one or more embodiments, placing the weir 264 in the groove 240 requires pushing the top piece 210 rearward past a slight interference with the bottom piece 174. When the bottom edge margin of the weir 264 is received in the groove 240, the weir sealingly engages the bottom wall 220 such that water flowing along the distributor flow path FP is inhibited from flowing through an interface between the bottom edge margin of the weir and the bottom wall and is instead directed to flow across the weir through the plurality of openings 266.

[00109] The weir 264 extends widthwise along a middle section of the assembled distributor 25, at a location spaced apart between the front wall 260 and the rear wall 236. The only couplings between the top distributor piece 210 and the bottom distributor piece 174 at this middle section of the distributor 25 are the tongue-and-groove connections at the left and right end portions of the distributor. Thus, in the illustrated embodiment, the middle section of the distributor 25 includes couplings at the first and second end portions of the distributor that restrain upward movement of the top distributor piece 210 with respect to the bottom distributor piece 174, but the distributor is substantially free of restraints against upward movement of the top distributor piece relative the bottom distributor piece along the middle section of the distributor at locations between these couplings. However, because the bottom edge margin of the weir 264 is convex and the groove 240 is correspondingly concave in the widthwise direction (FIG. 32), even as the distributor pieces 174, 210 flex and deform during use, the seal between the weir and the bottom wall 220 is maintained and water

is reliably directed to flow through of openings 266, instead of downward through the interface between the weir and the bottom wall.

IX.D. Water Flow through Distributor

[00110] Referring to FIG. 20, the distributor 25 is configured to direct water to flow from the inlet 212 to the outlet 214 such that the water flows along the flow path FP between the bottom and top walls 220, 258 and then is directed downward along the surface tension curve 247 and the water fall surface 249 onto the top portion of the freeze plate 22. Initially, the water flows generally in the forward direction from the inlet tube 238 through the inlet opening 212 in the rear wall 236. The water then encounters the lateral diverter wall 246. The lateral diverter wall 246 diverts at least some of the water laterally outward, such that the water continues forward through the widthwise gaps between the end portions of the lateral diverter wall and the end portions of the distributor 25.

[00111] After flowing past the lateral diverter wall 246, the water encounters the ramp surface 242 and the segmented weir 264. The ramp surface 242 is immediately upstream of the weir 264 such that the water flowing along the bottom wall 220 of the distributor 25 must flow upward along the ramp surface before flowing across the weir. The weir 264 is configured so that the openings 266 are spaced apart above the bottom wall 220 (e.g., the bottom edges of the openings are spaced apart above the apex of the ramp surface 242). Thus, in the illustrated embodiment, the water must flow upward along the ramp surface 242, and upward along a portion of the height of the weir 264 before it can flow through the openings 266 across the weir. In one or more embodiments, the weir 264 is configured so that the portion of the distributor 25 upstream of the weir backfills with water to a level that generally corresponds with the height of the bottom edges of the openings 266 before the water begins to spill over the weir through the openings. In certain embodiments, the ramp surface 242 can direct at least some of the water flowing in the forward direction FD along the ramp surface to flow through the openings 266 before the upstream portion of the distributor 25 fills with water to a level that corresponds with the height of the bottom edges of the

openings. After flowing across the weir 264, the water drops downward onto the sloped front runoff section 222 of the bottom wall 220 and then flows downward and forward.

[00112] As can be seen, the upper rear edge of the front runoff section 222 is spaced apart below the openings 266 by a substantially greater distance than the apex of the ramp surface 242. Thus, the water falls a relatively great distance from the segmented weir 264 onto the front runoff section 222, which may create turbulence on impact, enhancing the distribution of water in the distributor 25. In one or more embodiments, the vertical distance between the bottom edges of the openings 266 and the upper rear edge of the front runoff section 222 is at least 5 mm; e.g., at least 7 mm, e.g., at least 10 mm; e.g., about 12 to 13 mm.

[00113] Referring to FIG. 20A, in the assembled distributor 25, the front wall 260 of the top distributor piece 210 forms an overhanging front wall that overhangs the bottom wall 220. The bottom edge margin of the front wall 260 is spaced apart above the forwardly/downwardly sloping front runoff section 222 of the bottom wall 220 such that a flow restriction 270 is defined between the runoff section and the overhanging front wall. The flow restriction 270 comprises a gap (e.g., a continuous gap) that extends widthwise between the first end portion and the second end portion of the distributor 25. In general, the flow restriction 270 is configured to restrict a rate at which water flows through the flow restriction toward the outlet 214. In one or more embodiments, the flow restriction 270 has a height extending vertically from the runoff section 222 to the bottom of the front wall 260 of less than 10 mm, e.g., less than 7 mm; e.g., less than 5 mm; e.g., about 2 to 3 mm.

[00114] The water flowing forward along the front section 222 reaches the flow restriction 270, and the flow restriction arrests or slows the flow of water. In one or more embodiments, the overhanging front wall 260 acts as a kind of inverted weir. The flow restriction 270 slows the flow of water to a point at which water begins to slightly backfill the front portion of the distributor 25. This creates a small reservoir of water behind the flow restriction 270. A metered amount of water flows continuously from this back-filled reservoir through the flow restriction 270 along substantially the entire width WD of the distributor 25.

[00115] The surface tension curve 247—and more broadly the downstream end portion of the bottom wall 220—is forwardly proud of the overhanging front wall 260 and the flow restriction 270. After the water flows (e.g., is metered) through the flow restriction 270, the water adheres to the downwardly curving surface tension curve 247 as it flows generally forward. The surface tension curve 247 directs the water downward onto the waterfall surface 249. The water adheres to the waterfall surface 249 and flows downward along it. Finally the water is discharged from the outlet edge 214 of the waterfall surface 249 onto the top end portion of the freeze plate 22.

[00116] Because of water distribution features such as one or more of the lateral diverter wall 246, the ramp surface 242, the segmented weir 264, the flow restriction 270, the surface tension curve 247, and the waterfall surface 249, water is discharged from the outlet 214 at a substantially uniform flow rate along the width WD of the distributor 25. The distributor 25 thus directs water imparted through the distributor to flow downward along the front of the freeze plate 22 generally uniformly along the width WF of the freeze plate during an ice making cycle. Moreover, the distributor 25 controls the dynamics of the flowing water so that the water generally adheres to the surfaces of the front of the freeze plate 22 as it flows downward. Thus, the distributor 25 enables ice to form at a generally uniform rate along the height HF and width WF of the freeze plate 22.

X. Use

[00117] Referring again to FIG. 1, during use the ice maker 10 alternates between ice making cycles and harvest cycles. During each ice making cycle, the refrigeration system is operated to cool the freeze plate 22. At the same time, the pump 62 imparts water from the sump 70 through the water line 63 and further through the distributor 25. The distributor 25 distributes water along the top portion of the freeze plate 22 which freezes into ice in the molds 150 at a generally uniform rate along the height HF and width WF of the freeze plate 22. When the ice reaches a thickness that is suitable for harvesting, the pump 62 is turned off and the hot gas valve 24 redirects hot refrigerant gas to the evaporator tubing 21. The hot gas warms the freeze plate 22, causing the ice to

melt. The melting ice falls by gravity from the forwardly slanted freeze plate 22 into the bin 30. When harvest is complete, the pump 62 can be reactivated to begin a new ice making cycle. But if additional ice is not required, the discharge valve 79 is opened. Residual water in the distributor 25 drains into the sump 70 as described above, and the water from the sump drains through the discharge line 78. The discharge valve 79 can be closed when the water level sensor 64 detects that the sump 70 is empty. If repair or maintenance of the distributor 25 should ever be required, a technician can simply open the door 52 to the enclosure and pull out the top piece 210 as described above. No fasteners are used when removing and replacing the top distributor piece 210.

[00118] When introducing elements of the present invention or the preferred embodiment(s) thereof, the articles "a", "an", "the" and "said" are intended to mean that there are one or more of the elements. The terms "comprising", "including" and "having" are intended to be inclusive and mean that there may be additional elements other than the listed elements.

[00119] In view of the above, it will be seen that the several objects of the invention are achieved and other advantageous results attained.

[00120] As various changes could be made in the above products and methods without departing from the scope of the invention, it is intended that all matter contained in the above description shall be interpreted as illustrative and not in a limiting sense.

WHAT IS CLAIMED IS:

1. An ice maker comprising:
 - a freeze plate defining a plurality of molds in which the ice maker is configured to form ice, the freeze plate having a front defining open front ends of the molds, a back defining enclosed rear ends of the molds, a top portion and a bottom portion spaced apart along a height, and a first side portion and a second side portion spaced apart along a width; and
 - a distributor adjacent the top portion of the freeze plate, the distributor being configured to direct water imparted through the distributor to flow downward along the front of the freeze plate along the width of the freeze plate, the distributor comprising:
 - a first end portion and a second end portion spaced apart along a width of the distributor;
 - a bottom wall extending widthwise from the first end portion to the second end portion and extending generally forward from an upstream end portion to a downstream end portion, wherein the distributor is configured to direct the water imparted therethrough to flow in a generally forward direction from the upstream end portion to the downstream end portion, and
 - a weir extending upward from the bottom wall at a location spaced apart between the upstream end portion and the downstream end portion, the weir configured so that the water flows across the weir as it flows along the bottom wall from the upstream end portion to the downstream end portion;
 - wherein the bottom wall comprises a ramp surface, immediately upstream of the weir, sloping upward in the generally forward direction.
2. An ice maker as set forth in claim 1, wherein the bottom wall comprises an upstream segment upstream of the ramp surface, the ramp surface being oriented at an angle with respect to the upstream segment.
3. An ice maker as set forth in claim 1, wherein the weir comprises a segmented weir.

4. An ice maker as set forth in claim 1, wherein the bottom wall comprises a runoff section sloping downward from the weir to the downstream end portion.

5. An ice maker as set forth in claim 4, wherein the distributor further comprises an overhanging front wall having a bottom edge margin that is spaced apart above the runoff section to define a flow restriction between the runoff section and the overhanging front wall.

6. An ice maker as set forth in claim 5, wherein the flow restriction comprises a gap extending continuously between the first end portion and the second end portion of the distributor.

7. An ice maker as set forth in claim 5, wherein the downstream end portion of the bottom wall is forwardly proud of the overhanging front wall.

8. An ice maker as set forth in claim 1, wherein the downstream end portion of the bottom wall defines a surface tension curve extending downwardly, the surface tension curve being configured so that surface tension causes the water imparted through the distributor to adhere to the surface tension curve and be directed downward by the surface tension curve toward the top end portion of the freeze plate.

9. An ice maker as set forth in claim 1, wherein the distributor comprises an inlet opening adjacent the upstream end portion of the bottom wall, the inlet opening being spaced apart between the first end portion and the second end portion of the distributor.

10. An ice maker as set forth in claim 9, wherein the distributor further comprises a lateral diverter wall extending upward from the bottom wall at a location spaced apart between the inlet opening and the weir, the lateral diverter wall extending widthwise from a first end portion spaced apart from the first end portion of the

distributor to a second end portion spaced apart from the second end portion of the distributor.

11. An ice maker comprising:

a freeze plate defining a plurality of molds in which the ice maker is configured to form ice, the freeze plate having a front defining open front ends of the molds, a back defining enclosed rear ends of the molds, a top portion and a bottom portion spaced apart along a height, and a first side portion and a second side portion spaced apart along a width; and

a distributor adjacent the top portion of the freeze plate, the distributor being configured to direct water imparted through the distributor to flow downward along the front of the freeze plate along the width of the freeze plate, the distributor comprising:

a first end portion and a second end portion spaced apart along a width of the distributor, and

a bottom wall extending widthwise from the first end portion to the second end portion and extending generally forward from an upstream end portion to a downstream end portion, wherein the distributor is configured to direct the water imparted therethrough to flow in a generally forward direction from the upstream end portion to the downstream end portion,

wherein the downstream end portion of the bottom wall defines a downwardly curving surface tension curve, the downwardly curving surface tension curve being configured so that surface tension causes the water imparted through the distributor to adhere to the curve and be directed downward by the curve toward the top end portion of the freeze plate.

12. An ice maker as set forth in claim 11, wherein the distributor further comprises a waterfall surface extending generally downward from the surface tension curve to the top end portion of the freeze plate, the waterfall surface being configured so that surface tension causes the water imparted through the distributor to adhere to the waterfall surface and flow downward along the waterfall surface onto the top end portion of the freeze plate.

13. An ice maker as set forth in claim 11, wherein the surface tension curve is at least partially defined by a radius of at least 1 mm.

14. An ice maker as set forth in claim 11, wherein the distributor further comprises an overhanging front wall having a bottom edge margin that is spaced apart above the bottom wall such that a flow restriction is defined between the bottom wall and the overhanging front wall.

15. An ice maker as set forth in claim 14, wherein the flow restriction gap extends continuously between the first end portion and the second end portion of the distributor.

16. An ice maker as set forth in claim 14, wherein the surface tension curve is forwardly proud of the overhanging front wall.

17. An ice maker as set forth in claim 11, wherein the distributor comprises a weir upstream of the surface tension curve.

18. An ice maker comprising:
a freeze plate defining a plurality of molds in which the ice maker is configured to form ice, the freeze plate having a front defining open front ends of the molds, a back defining enclosed rear ends of the molds, a top portion and a bottom portion spaced apart along a height, and a first side portion and a second side portion spaced apart along a width; and

a distributor adjacent the top portion of the freeze plate, the distributor being configured to direct water imparted through the distributor to flow downward along the front of the freeze plate along the width of the freeze plate, the distributor comprising:

a first end portion and a second end portion spaced apart along a width of the distributor,

a bottom wall extending widthwise from the first end portion to the second end portion and extending generally forward from an upstream end portion to a downstream end portion, wherein the distributor is configured to direct the water imparted therethrough to flow in a generally forward direction from the upstream end portion to the downstream end portion, and

an overhanging front wall having a bottom edge margin spaced apart above the bottom wall adjacent the downstream end portion thereof such that a flow restriction is defined between the bottom wall and the overhanging front wall, the flow restriction comprising a gap extending widthwise between the first end portion and the second end portion of the distributor and being configured to restrict a rate at which water flows through the flow restriction to the downstream end portion of the bottom wall.

19. An ice maker as set forth in claim 18, wherein the gap has a height of less than 10 mm.

20. An ice maker as set forth in claim 18, wherein the gap extends continuously between the first end portion and the second end portion of the distributor.

21. An ice maker as set forth in claim 18, wherein the bottom wall slopes forwardly and downwardly across the flow restriction.

22. An ice maker as set forth in claim 18, wherein the downstream end portion of the bottom wall is forwardly proud of the overhanging front wall.

23. An ice maker as set forth in claim 18, wherein the distributor comprises a weir upstream of the flow restriction.

24. An ice maker comprising:
a freeze plate defining a plurality of molds in which the ice maker is configured to form ice, the freeze plate having a top portion and a bottom portion spaced apart along a height and a first side portion and a second side portion spaced apart along a width; and
a distributor extending along the width of the freeze plate adjacent the top portion of the freeze plate, the distributor being configured to direct water imparted through the distributor to flow from the top portion of the freeze plate to the bottom portion along the width of the freeze plate;
wherein the distributor comprises a first distributor piece and a second distributor piece, the second distributor piece configured to be releasably coupled to the first distributor piece without separate fasteners to form the distributor.
25. An ice maker as set forth in claim 24, wherein the first distributor piece and the second distributor piece have complementary integral fittings configured to engage one another to couple the second distributor piece to the first distributor piece.
26. An ice maker as set forth in claim 25, wherein the ice maker further comprises an enclosure having an access opening, the distributor being received at an interior position in the enclosure, the integral fittings being configured to be disengaged for removal of the second distributor piece when the second distributor piece is urged away from the interior position in a direction toward the access opening.
27. An ice maker as set forth in claim 24, wherein each of the first distributor piece and the second distributor piece has a first end wall adjacent the first side portion and a second end wall adjacent the second side portion.
28. An ice maker as set forth in claim 27, wherein second distributor piece is configured to nest between the first and second end walls of the first distributor piece when the second distributor piece is coupled to the first distributor piece.

29. An ice maker as set forth in claim 27, wherein the first end walls of the first and second distributor pieces define a first pair of complementary fittings configured to couple the second distributor piece to the first distributor piece and the second end walls of the first and second distributor pieces define a second pair of complementary fittings configured to couple the second distributor piece to the first distributor piece.

30. An ice maker as set forth in claim 29, wherein each pair of complementary fittings comprises a female fitting and a male fitting configured to be received in the female fitting.

31. An ice maker as set forth in claim 30, further comprising an enclosure having an access opening, wherein each male fitting is configured to be received in the female fitting as the second distributor piece moves relative to the first distributor piece in a direction extending inward from the access opening toward the first piece.

32. An ice maker as set forth in claim 30, wherein each female fitting comprises an elongate groove having an open end and each male fitting comprises an elongate tongue configured to be slidably received in the respective elongate groove through the respective open end.

33. An ice maker as set forth in claim 32, wherein each pair of complementary fittings includes a detent configured to keep the respective tongue at a coupling position along the respective elongate groove.

34. An ice maker as set forth in claim 24, wherein the first distributor piece comprises a bottom wall defining a widthwise groove configured to receive a portion of the second distributor piece therein when the second distributor piece is coupled to the first distributor piece.

35. An ice maker as set forth in claim 34, wherein the second distributor piece comprises a generally vertical weir having a free edge margin configured to be received in the widthwise groove.

36. An ice maker as set forth in claim 35, wherein the free edge margin of the weir is convex in a widthwise direction and the groove is concave in a widthwise direction.

37. An ice maker comprising:
a freeze plate defining a plurality of molds in which the ice maker is configured to form ice, the freeze plate having a top portion and a bottom portion spaced apart along a height and a first side portion and a second side portion spaced apart along a width; and
a distributor adjacent the top portion of the freeze plate having a width extending along the width of the freeze plate, the distributor having an inlet and an outlet and defining a distributor flow path extending from the inlet to the outlet, the distributor being configured to direct water imparted through the distributor along the distributor flow path and discharge the water from the outlet such that the water flows from the top portion of the freeze plate to the bottom portion along the width of the freeze plate, the distributor comprising a first distributor piece and a second distributor piece, the second distributor piece being releasably coupled to the first distributor piece to form the distributor, the first distributor piece comprising a bottom wall defining a groove extending widthwise and the second distributor piece comprising a generally vertical weir defining a plurality of openings spaced apart along the width of the distributor, the weir having a free bottom edge margin received in the groove such that water flowing along the distributor flow path is inhibited from flowing through an interface between the bottom edge margin of the weir and the bottom wall and is directed to flow across the weir through the plurality of openings.

38. An ice maker as set forth in claim 37, wherein the free edge margin of the weir is convex in a widthwise direction.

39. An ice maker as set forth in claim 37, wherein the groove is concave in a widthwise direction.

40. An ice maker as set forth in claim 37:
wherein the distributor comprises a front and a rear and the weir extends widthwise along a middle section located between the front and the rear of the distributor;

wherein the distributor further comprises a first end portion and a second end portion spaced apart along the width of the distributor, a first coupling at the first end portion providing a restraint against upward movement of the second distributor piece with respect to the first distributor piece at the middle section of the distributor, and second coupling at the second end portion providing a restraint against upward movement of the second distributor piece with respect to the first distributor piece at the middle section of the distributor; and

wherein the distributor is substantially free of restraint against upward movement of the second distributor piece with respect to the first distributor piece along the middle section of the distributor at locations along the width of the distributor between the first and second couplings.

41. An ice maker as set forth in claim 37, wherein the plurality of openings are spaced apart above the bottom wall.

42. An ice maker as set forth in claim 37, wherein the second distributor piece comprises a top wall and the distributor flow path passes between the bottom and top walls.

43. An ice maker as set forth in claim 37, wherein the distributor flow path comprises a first segment upstream of the weir and a second segment downstream of the weir.

44. An ice maker comprising:
an evaporator assembly comprising:

a freeze plate defining a plurality of molds in which the evaporator assembly is configured to form pieces of ice, the freeze plate having a front defining open front ends of the molds and a back extending along closed rear ends of the molds;

an evaporator housing having a back and defining an enclosed space between the back of the freeze plate and the back of the evaporator housing; refrigerant tubing received in the enclosed space; and insulation substantially filling the enclosed space around the refrigerant tubing; and

a water system configured to supply water to the freeze plate such that the water forms into ice in the molds;

wherein the evaporator housing includes a distributor piece formed from a single piece of monolithic material, the distributor piece being in direct contact with the insulation and having a bottom wall, the water system being configured direct the water to flow along the bottom wall as the water is supplied to the freeze plate.

45. An ice maker as set forth in claim 44, wherein the bottom wall of the distributor piece has a rear section located generally above the enclosed space and a front section located generally above the freeze plate.

46. An ice maker as set forth in claim 45, wherein the rear section defines a lower recess and a portion of the insulation is received in the lower recess.

47. An ice maker as set forth in claim 46, wherein the lower recess forms a top of the enclosed space.

48. An ice maker as set forth in claim 46, wherein the bottom wall of the distributor piece includes a downwardly extending rear leg and a downwardly extending front leg forwardly spaced from the rear leg, the lower recess being located between the rear and front legs.

49. An ice maker as set forth in claim 48, wherein the evaporator housing includes a back wall defining at least a portion of the back of the evaporator housing, the rear leg of the distributor piece being sealingly engaged with the back piece.

50. An ice maker as set forth in claim 45, wherein the freeze plate has a top wall defining a top end of at least one of the molds, the front section of the bottom wall of the distributor piece being sealingly engaged with the top wall of the freeze plate.

51. An ice maker as set forth in claim 44, wherein the freeze plate comprises a top wall and at least one stud joined to the top wall and extending upward therefrom.

52. An ice maker as set forth in claim 51, further comprising a nut tightened onto each stud to attach the distributor piece to the freeze plate.

53. An ice maker as set forth in claim 44, wherein the bottom wall comprises a central apex, a rear section sloping downward and generally rearward from adjacent the central apex to an upstream end portion of the bottom wall, and a front section sloping downward and generally forward from adjacent the central apex to a downstream end portion of the bottom wall.

54. An ice maker as set forth in claim 53, wherein the distributor piece includes a rear wall adjacent the upstream end portion of the bottom wall and a tube protruding rearward from the rear wall.

55. An ice maker as set forth in claim 54, wherein the tube communicates through an opening in the rear wall immediately above the upstream end portion of the bottom wall.

56. An ice maker as set forth in claim 55, wherein the tube slopes rearward and downward.

57. An ice maker as set forth in claim 44, wherein the distributor piece includes one or more water distribution features.

58. An ice maker as set forth in claim 57, wherein the water distribution features include a weir and a ramp surface immediately upstream of the weir.

59. An ice maker as set forth in claim 57, wherein the water distribution features includes a surface tension curve configured such that water flowing along the bottom wall adheres to the surface tension curve and is directed downward by the surface tension curve.

60. An ice maker as set forth in claim 44, wherein the ice maker includes a water distributor assembly, and the distributor piece is a bottom piece of the distributor assembly, the distributor assembly further comprising a top piece configured to attach to the bottom piece without separate fasteners.

61. An ice maker comprising:
an evaporator assembly comprising a freeze plate defining a plurality of molds in which the evaporator assembly is configured to form pieces of ice, the freeze plate having a front defining open front ends of the molds, a back extending along closed rear ends of the molds, a top wall formed from a single piece of monolithic material and defining a top end of at least one of the molds, and at least one stud joined to the top wall and extending upward therefrom; and

a distributor configured to distribute water imparted through the distributor over the freeze plate so that the water forms into ice in the molds, the distributor comprising:

a distributor piece formed from a single piece of monolithic material, the distributor piece comprising a bottom wall defining a portion of a flow path along which the distributor directs water to flow through the distributor; and

a nut tightened onto each stud against the distributor piece to directly mount the distributor on the freeze plate.

62. A distributor for receiving water imparted through the distributor and directing the water to flow along a freeze plate of an ice maker so that the water forms into ice on the freeze plate, the distributor comprising:

a rear wall adjacent an upstream end of the distributor;

a bottom wall extending forward from the rear wall to a front end portion adjacent a downstream end of the distributor; and

a tube protruding rearward from the rear wall, the rear wall having an opening immediately above the bottom wall through which the tube fluidly communicates with the distributor;

wherein the bottom wall comprises a rear section that slopes downward to the rear wall and a front section that slopes downward to the front end portion.

63. An ice maker comprising:

an enclosure;

a freeze plate received in the enclosure, the freeze plate comprising a back wall and a front opposite the back wall, the freeze plate further comprising a perimeter wall extending forward from the back wall, the perimeter wall comprising a top wall portion, a bottom wall portion, a first side wall portion, and a second side wall portion, the first side wall portion and the second side wall portion defining a width of the freeze plate, the freeze plate further comprising a plurality of heightwise divider plates extending from lower ends connected to the bottom wall portion to upper ends connected to the top wall portion and a plurality of widthwise divider plates extending from first ends connected to the first side wall portion to second ends connected to the second side wall portion, the heightwise divider plates and the widthwise divider plates being interconnected to define a plurality of ice molds inboard of the perimeter wall, each widthwise divider plate defining a plurality of molds immediately above the divider plate and a plurality of molds immediately below the divider plate, each widthwise divider plate sloping downward and forward away from the back wall of the freeze plate such that included angle between an upper surface of each widthwise divider plate and the back wall is greater than 90° and less than 180° ; and

a distributor configured to direct water imparted through the distributor to flow downward along the freeze plate along the width of the freeze plate;

wherein the freeze plate is supported in the enclosure so that the back wall of the freeze plate slants forward.

64. An ice maker as set forth in claim 63, wherein the back wall of the freeze plate and a plumb vertical axis have an included angle therebetween of at least about 1.5° .

65. An ice maker as set forth in claim 64, wherein the included angle between the back wall of the freeze plate and the plumb vertical axis is about 2.0° .

66. An ice maker as set forth in claim 63, wherein the included angle between a top surface of each widthwise divider plate and the back wall of the freeze plate is at least 100° .

67. An ice maker as set forth in claim 63, wherein each widthwise divider plate is formed from single piece of monolithic material.

68. An ice maker as set forth in claim 67, wherein each widthwise divider plate has a bottom surface and a top surface oriented parallel to the bottom surface.

69. An ice maker as set forth in claim 68, wherein the plurality of ice molds includes a plurality of interior ice molds having perimeters defined substantially entirely by the heightwise and widthwise divider plates.

70. An ice maker as set forth in claim 69, wherein each interior ice mold has an upper end defined substantially entirely by the bottom surface of one of the widthwise divider plates and a lower end defined substantially entirely by the top surface of one of the widthwise divider plates.

71. An ice maker as set forth in claim 63, wherein each widthwise divider plate has a front edge, the front edge of each widthwise divider plate lying substantially on a

front plane of the freeze plate, the front plane of the freeze plate being substantially parallel to the back wall.

72. An ice maker as set forth in claim 63, wherein the ice maker is configured to execute a harvest cycle by which ice is released from the molds, wherein substantially the only forces imparted on the ice during the harvest cycle are gravitational forces.

73. An ice maker as set forth in claim 63, wherein the distributor comprises a first end portion adjacent the first side wall portion of the perimeter wall of the freeze plate, a second end portion adjacent the second side wall portion of the perimeter wall of the freeze plate, and a bottom wall extending widthwise between the first end portion and the second end portion above the top wall portion of the perimeter wall of the freeze plate, the bottom wall having a downstream end portion adjacent the front of the freeze plate and an upstream end portion rearwardly spaced from the front end portion.

74. An ice maker as set forth in claim 73, wherein the downstream end portion of the freeze plate defines a surface tension curve configured so that the water imparted through the distributor adheres to the curve and is directed downward by the curve toward a front edge of the top wall portion of the freeze plate.

75. An ice maker as set forth in claim 74, wherein the distributor further comprises a waterfall surface extending generally downward from the surface tension curve.

76. An ice maker as set forth in claim 75, wherein the waterfall surface is substantially parallel to the back wall of the freeze plate.

77. An ice maker as set forth in claim 73, wherein the distributor further comprises an overhanging front wall having a bottom edge margin spaced apart above the bottom wall to define a flow restriction therebetween.

78. An ice maker as set forth in claim 73, wherein the distributor further comprises a weir spaced apart between the upstream end portion and the downstream end portion of the bottom wall.

79. An ice maker as set forth in claim 78, wherein the bottom wall of the distributor comprises a ramp surface immediately upstream of the weir.

80. An ice maker as set forth in claim 63, further comprising a support comprising at least one vertically extending support wall formed from a single monolithic piece of material, the support wall comprising an integrally formed freeze plate mount that is configured to mount the freeze plate on the support wall in the enclosure such that the back wall of the freeze plate slants forward.

81. An ice maker as set forth in claim 80, wherein the freeze plate mount comprises a lower connection point and an upper connection point forwardly spaced from the lower connection point.

82. An ice maker as set forth in claim 80, further comprising a sump, at least one of a water level sensor and a pump, and a mounting plate for supporting said at least one of the water level sensor and the pump in the enclosure at an operative position with respect to the sump, the at least one vertically extending support wall comprising an integral plate mount configured to mount the mounting plate on the support and an integral sump mount configured to mount the sump on the support.

FIG. 1

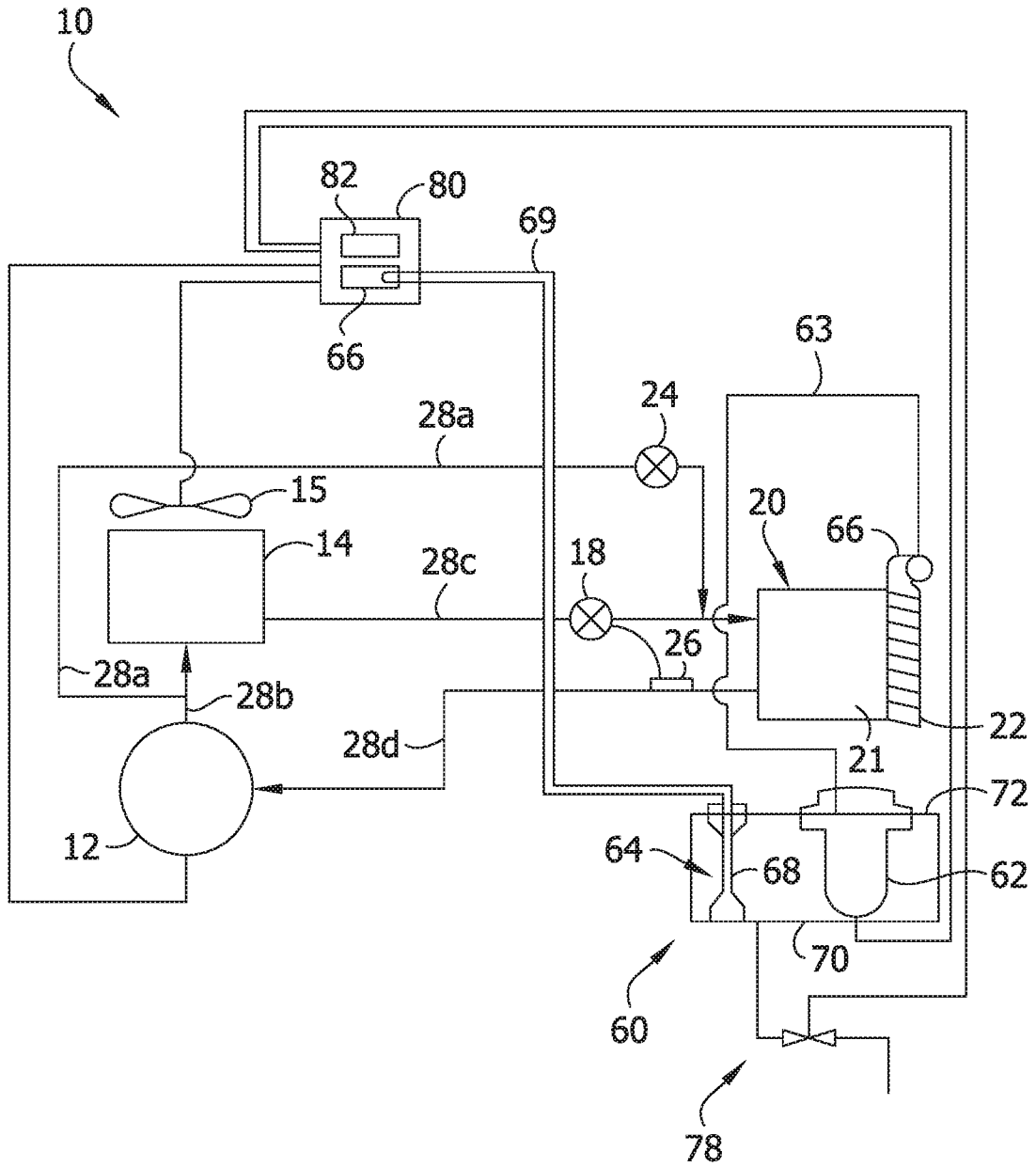
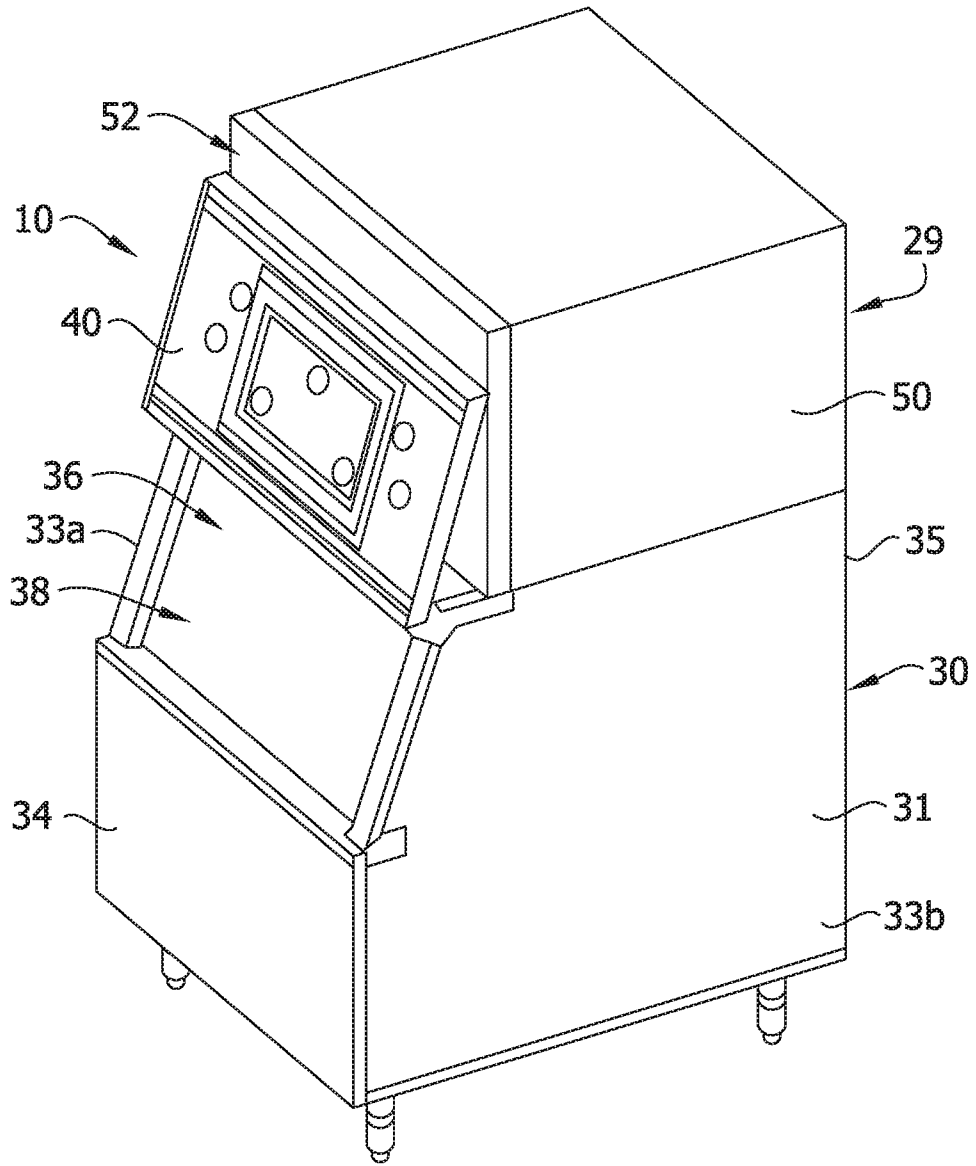

FIG. 2



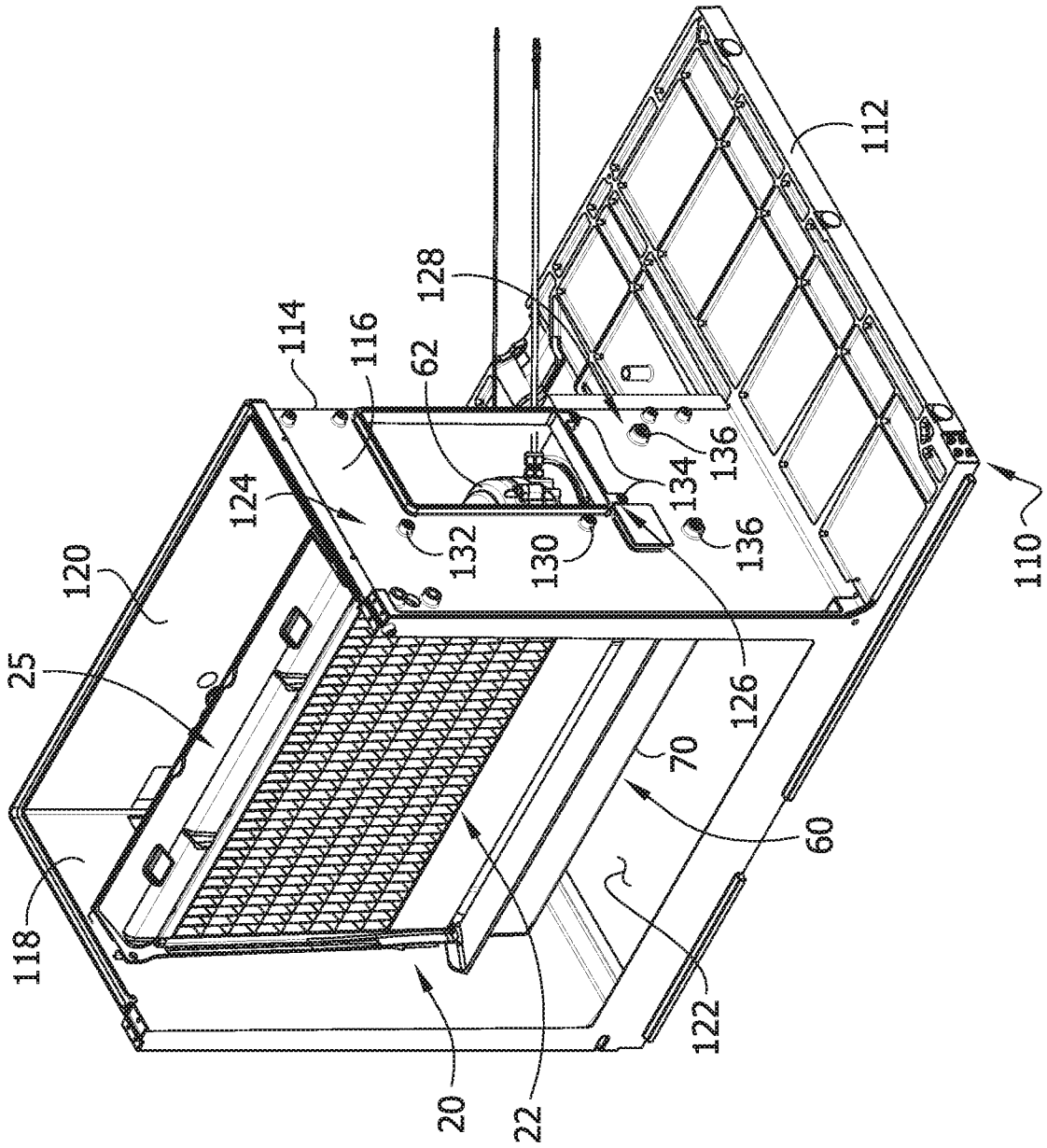

FIG. 3

FIG. 4

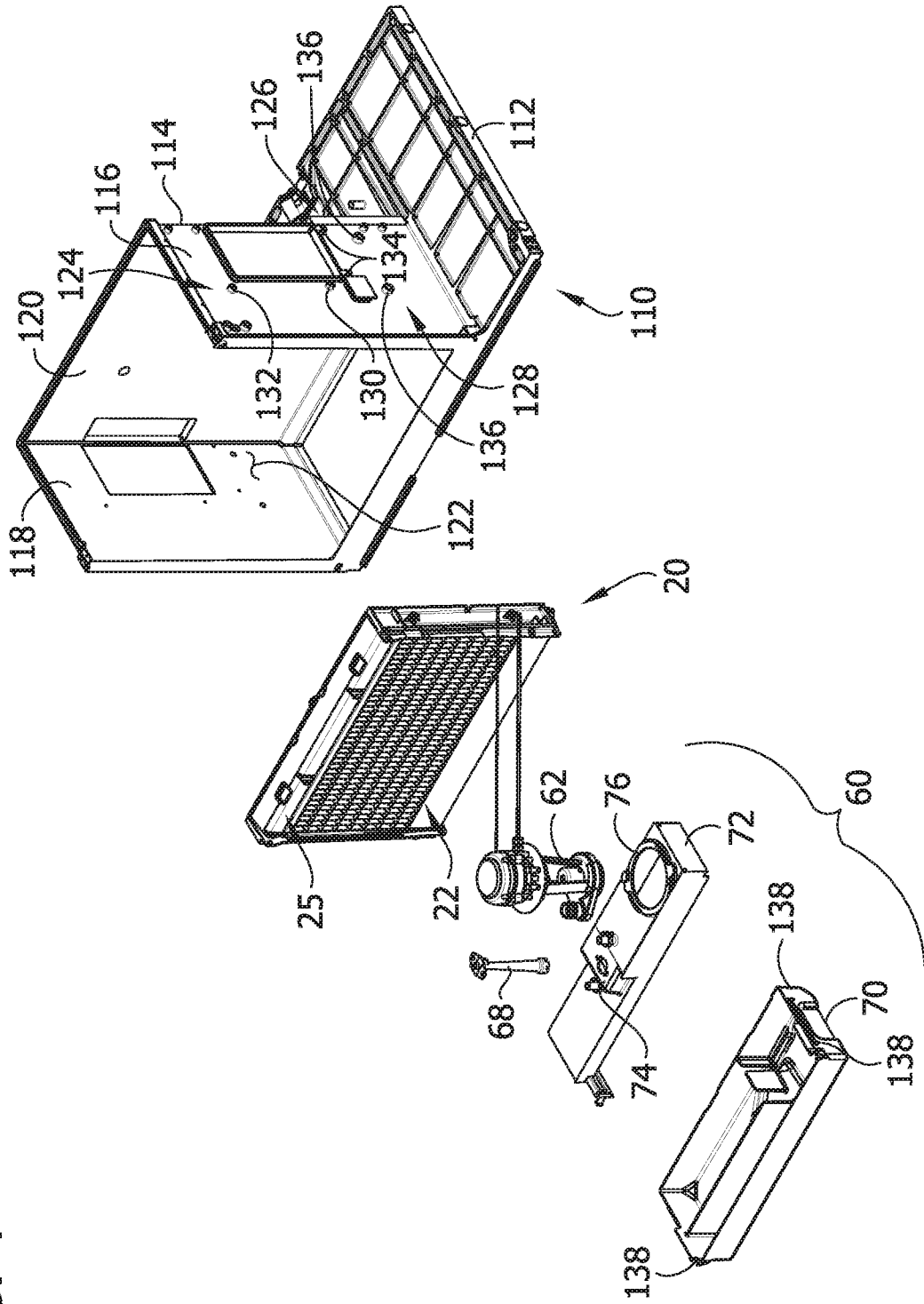
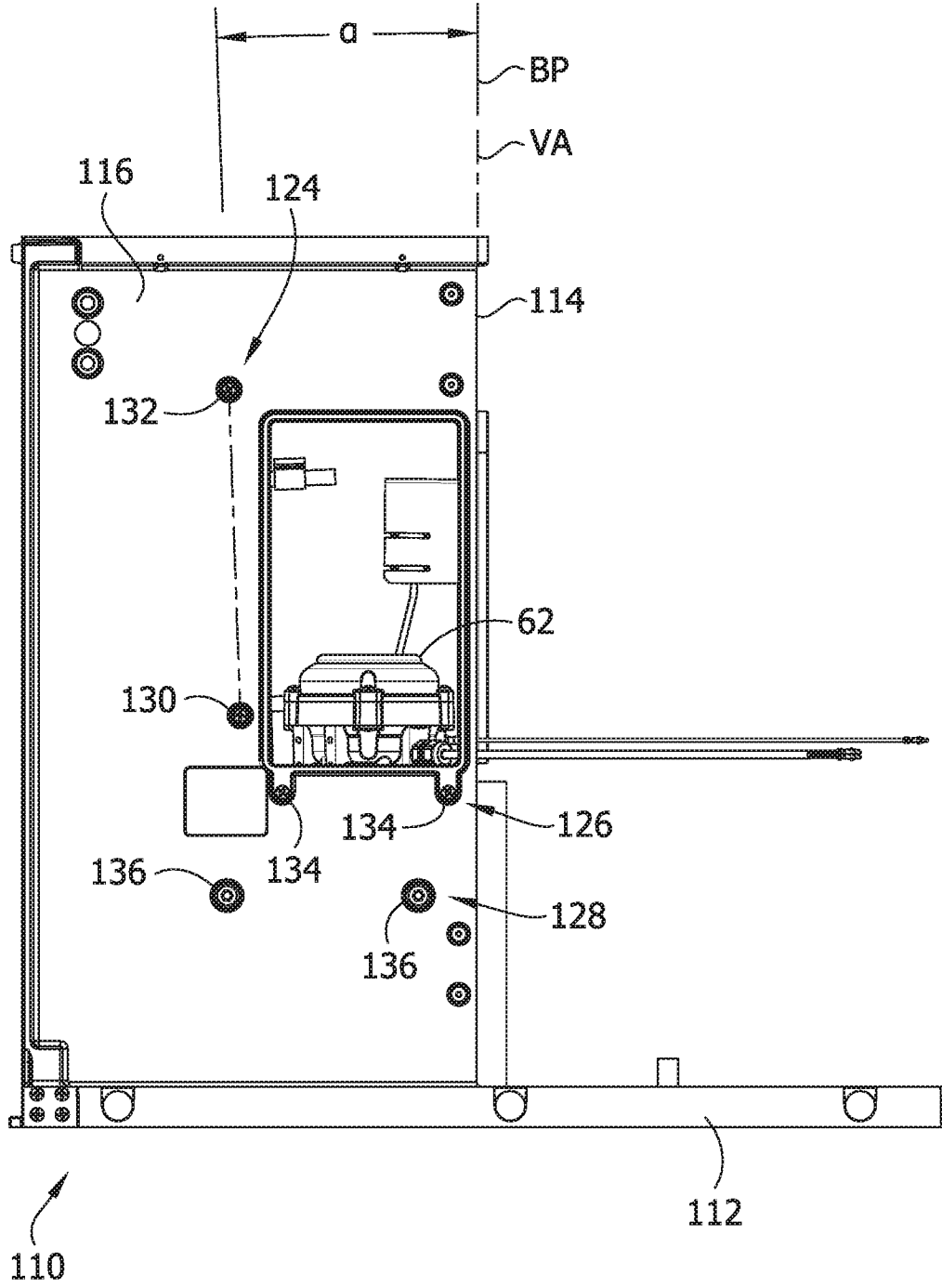

FIG. 5



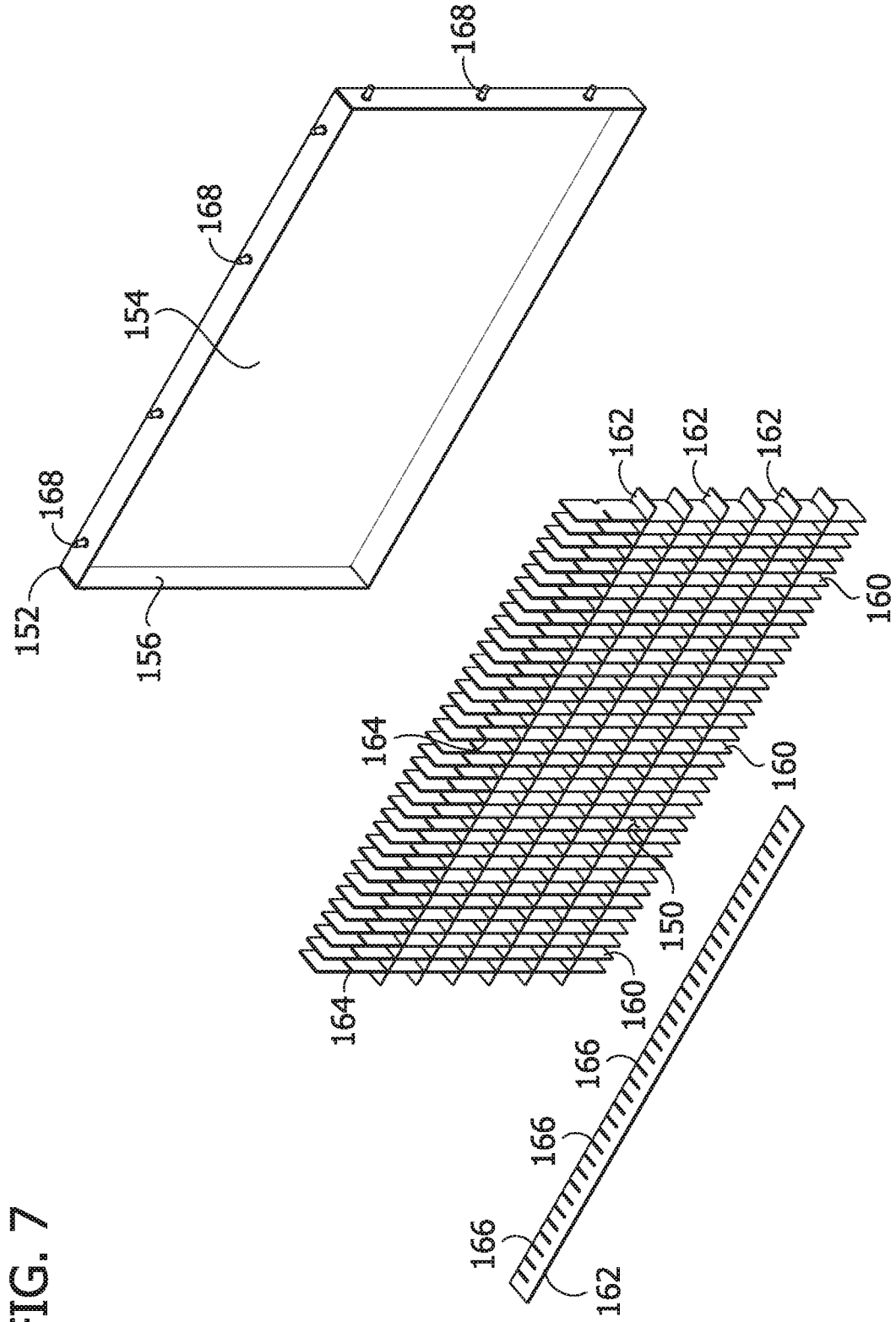

FIG. 7

FIG. 8

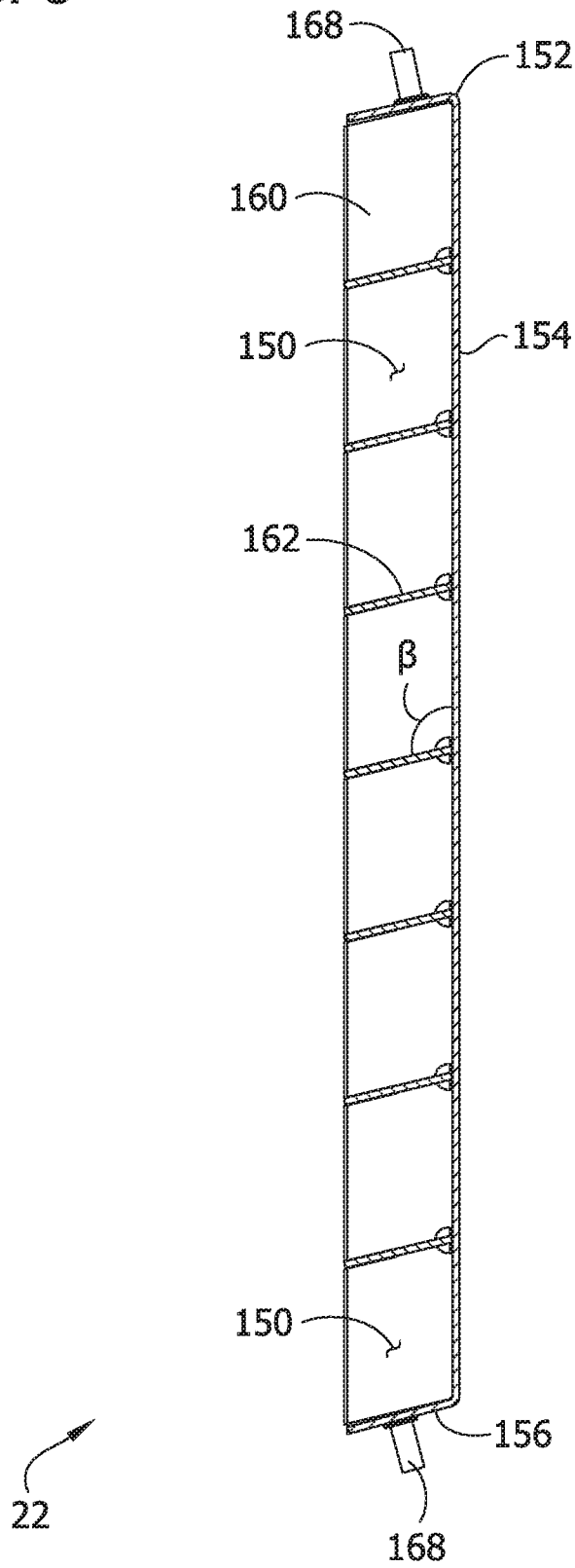

FIG. 9

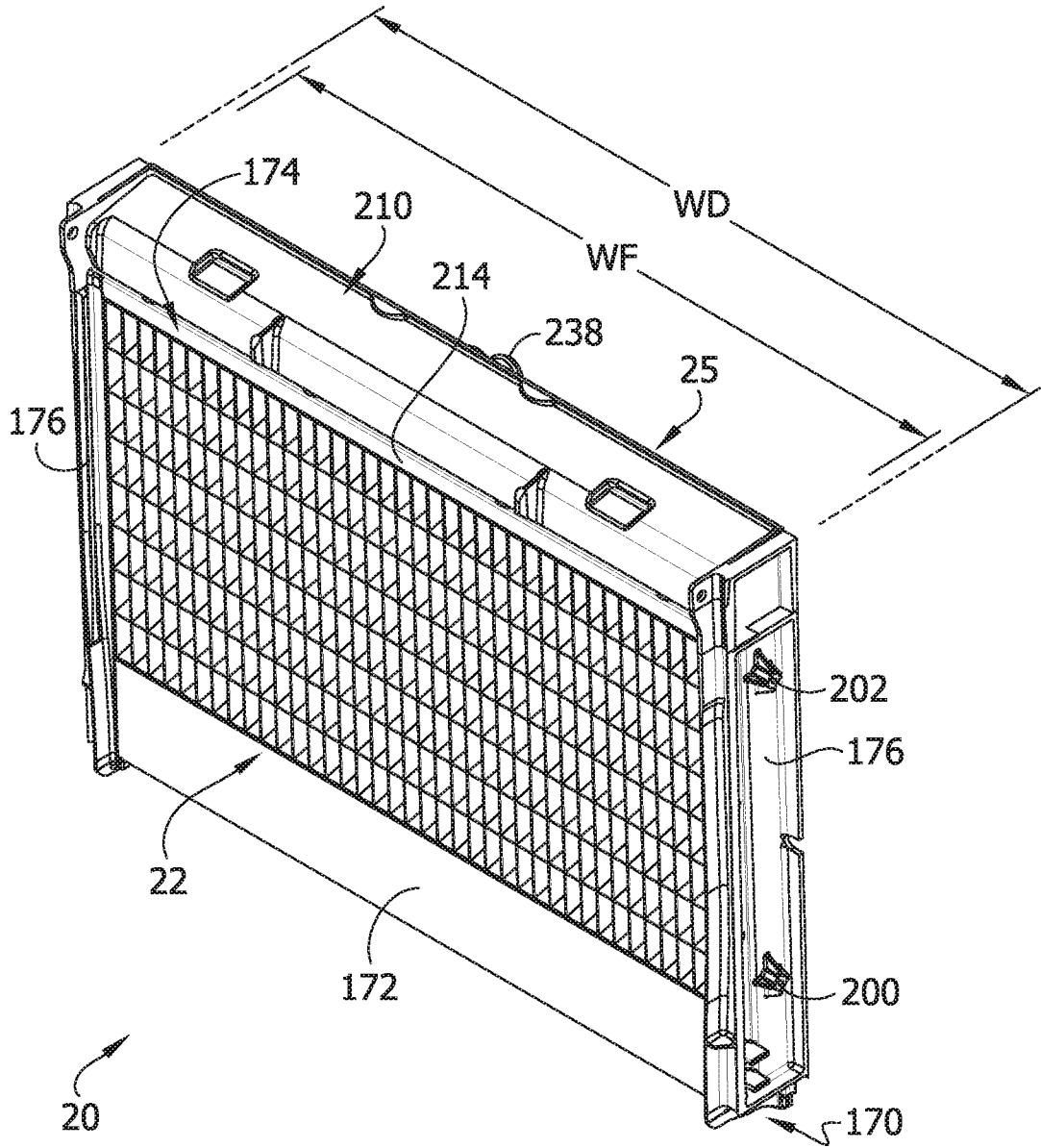

FIG. 10

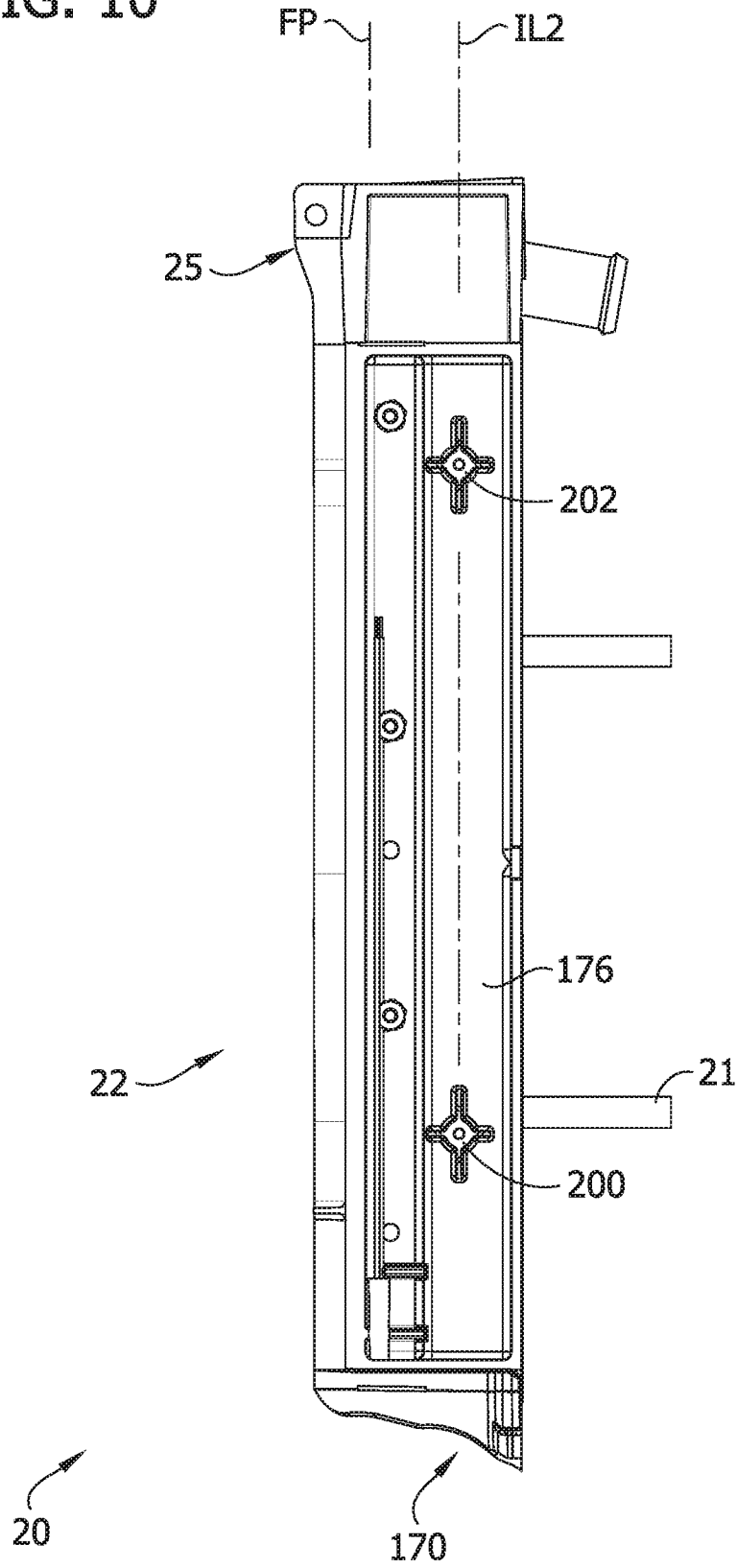
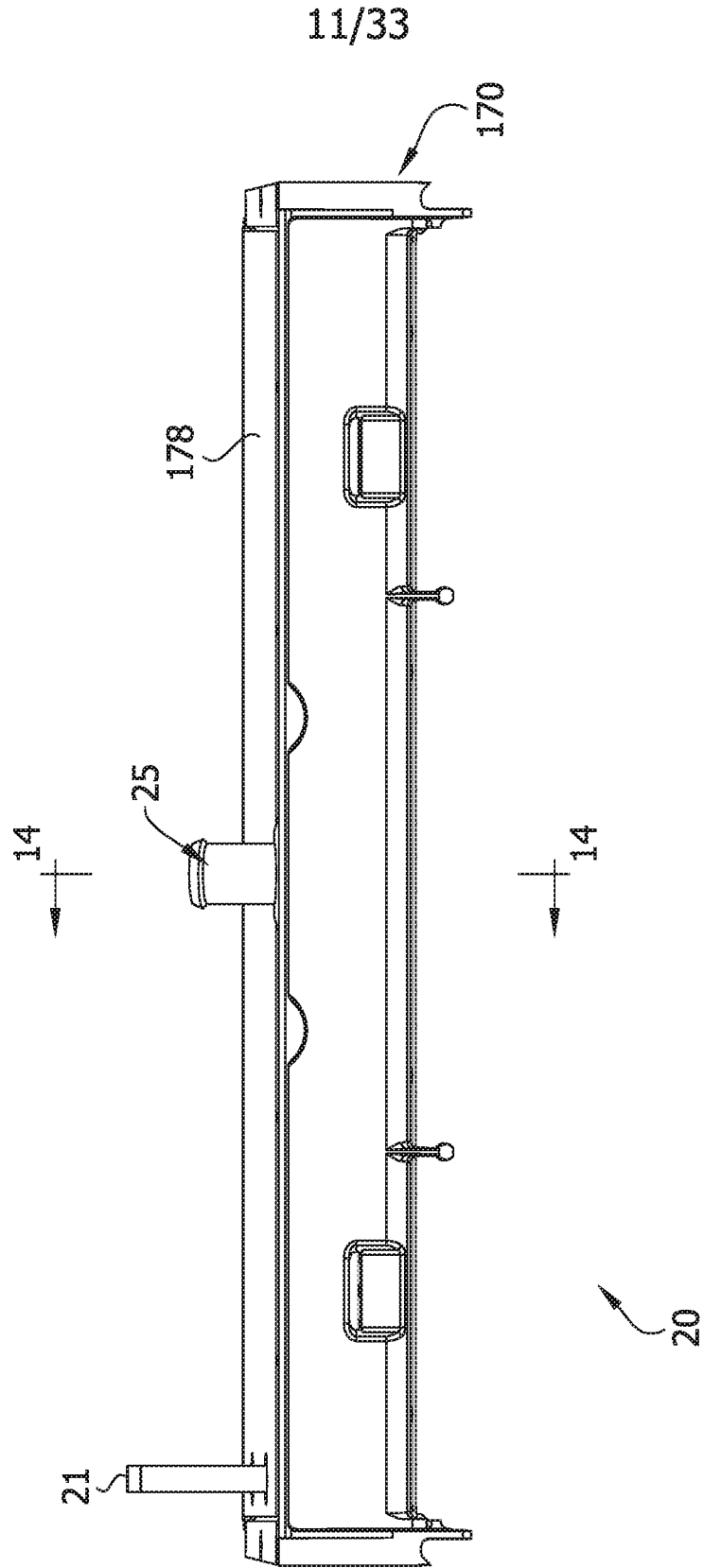

FIG. 11



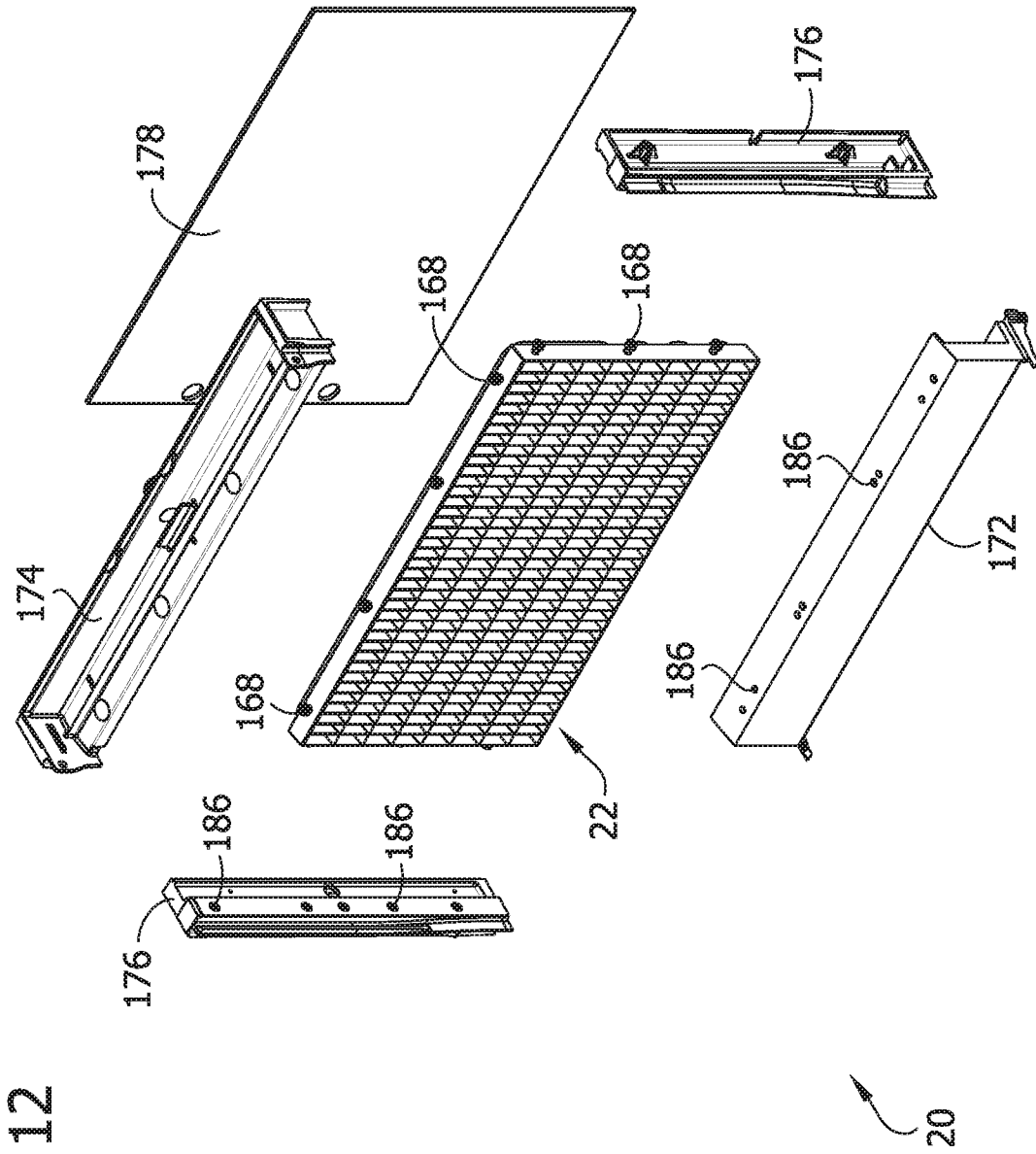

FIG. 12

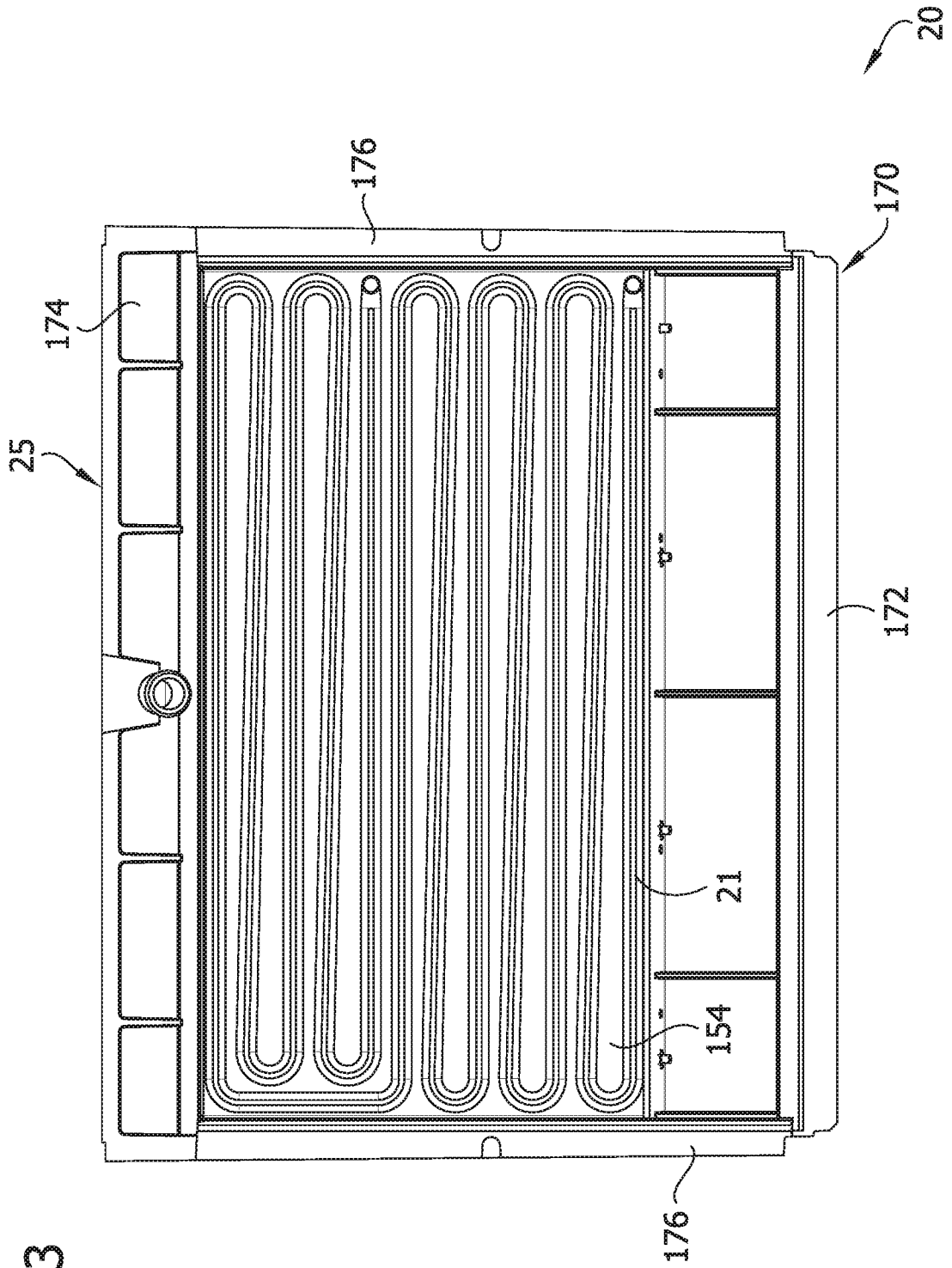

FIG. 13

FIG. 14

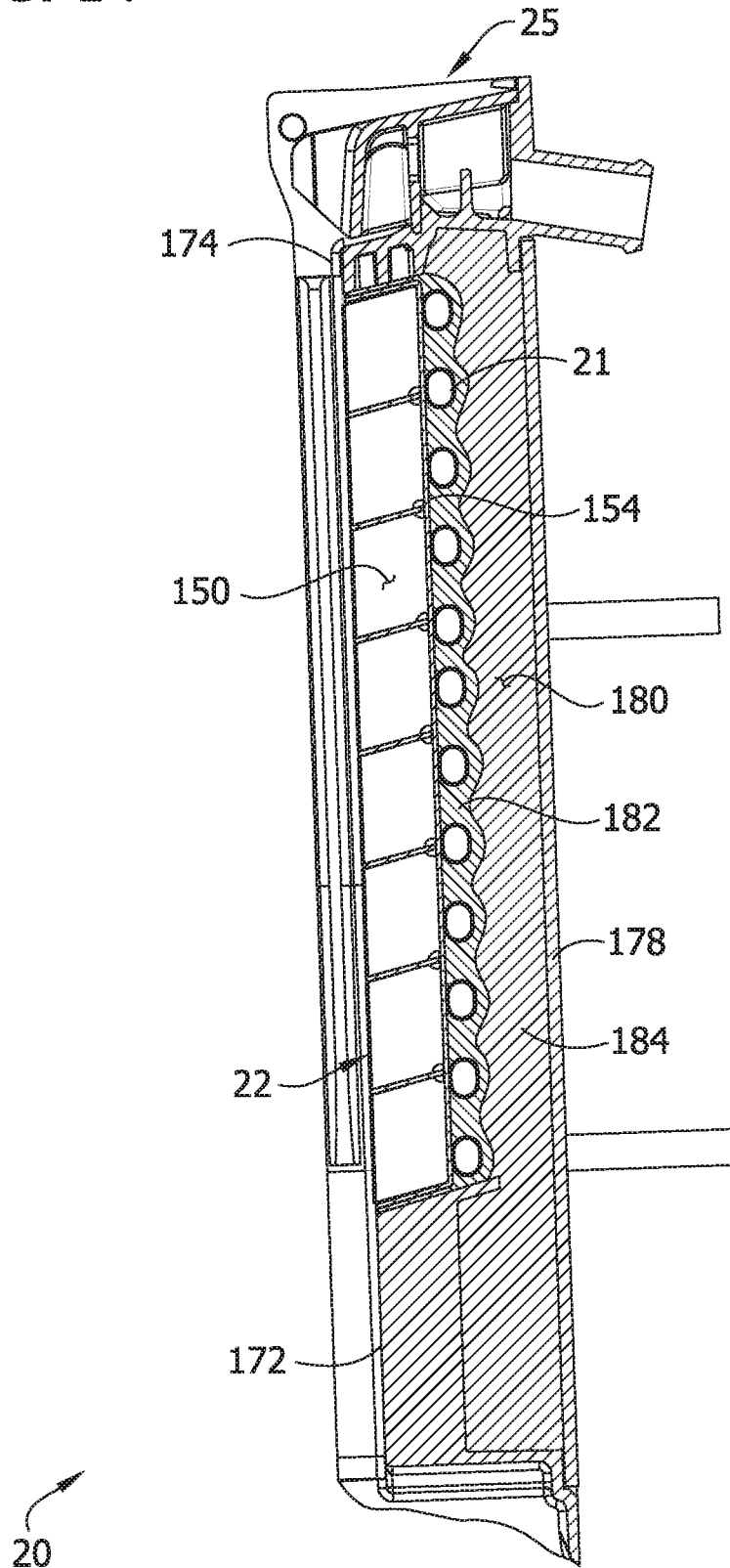

FIG. 15

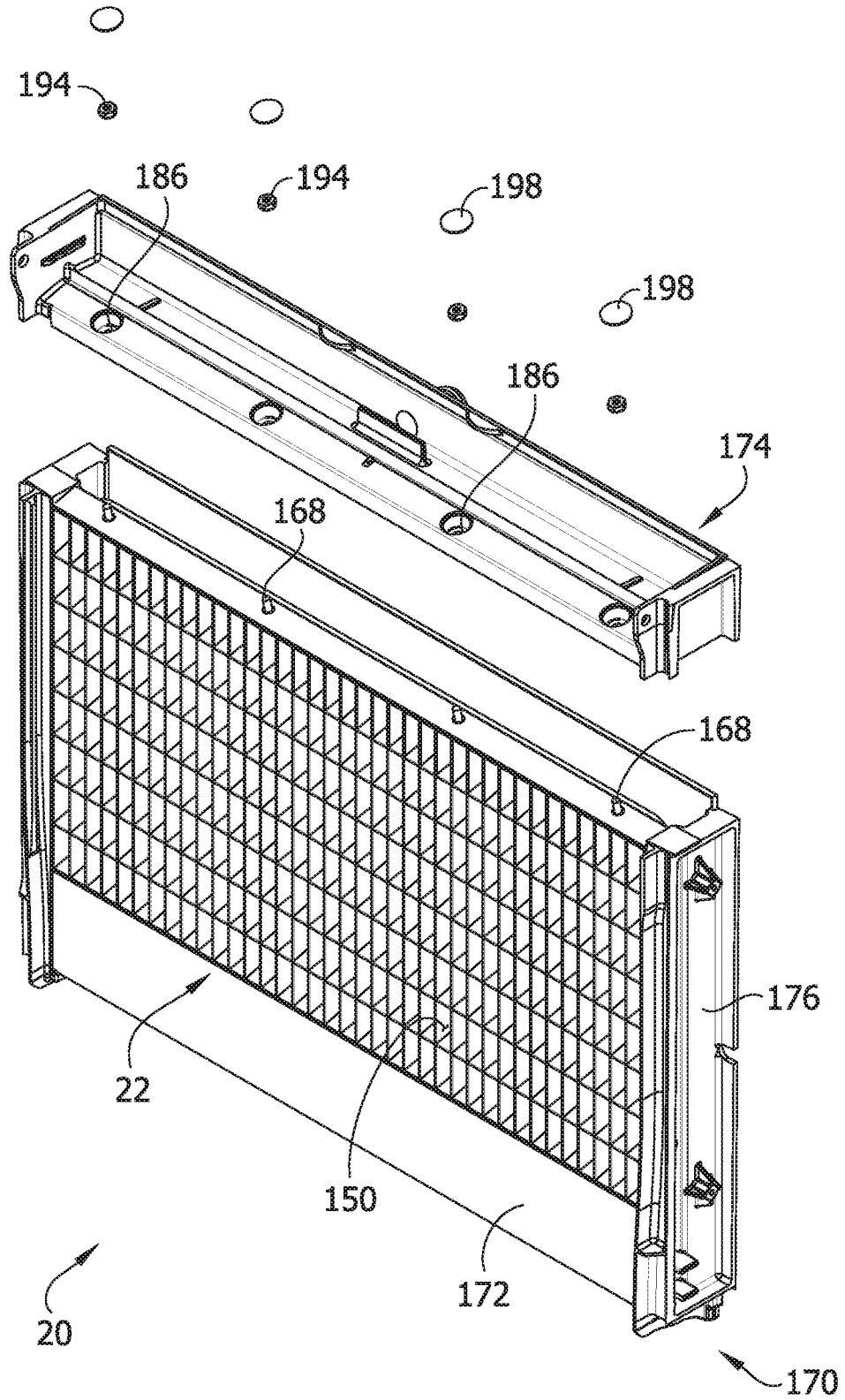

FIG. 17

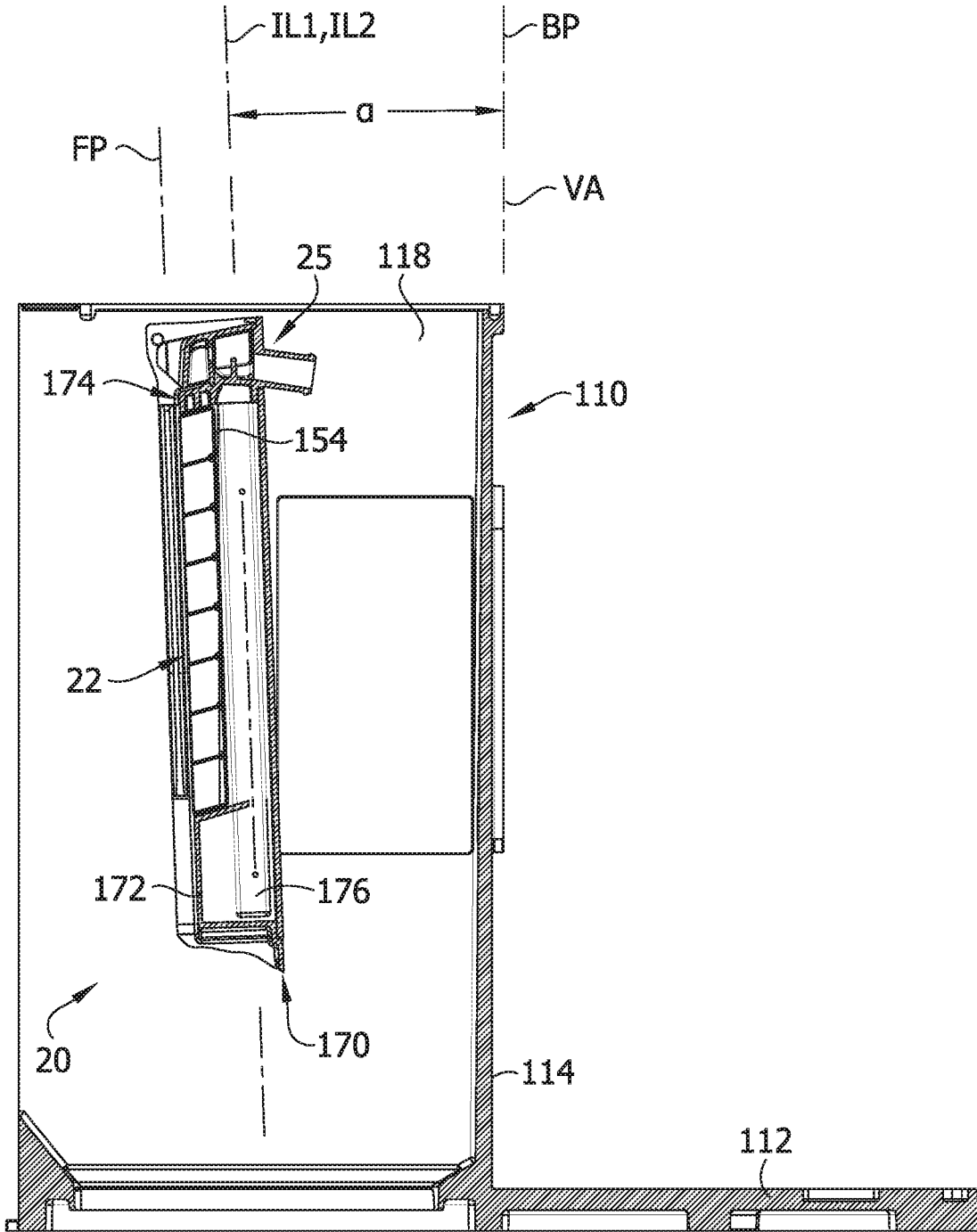
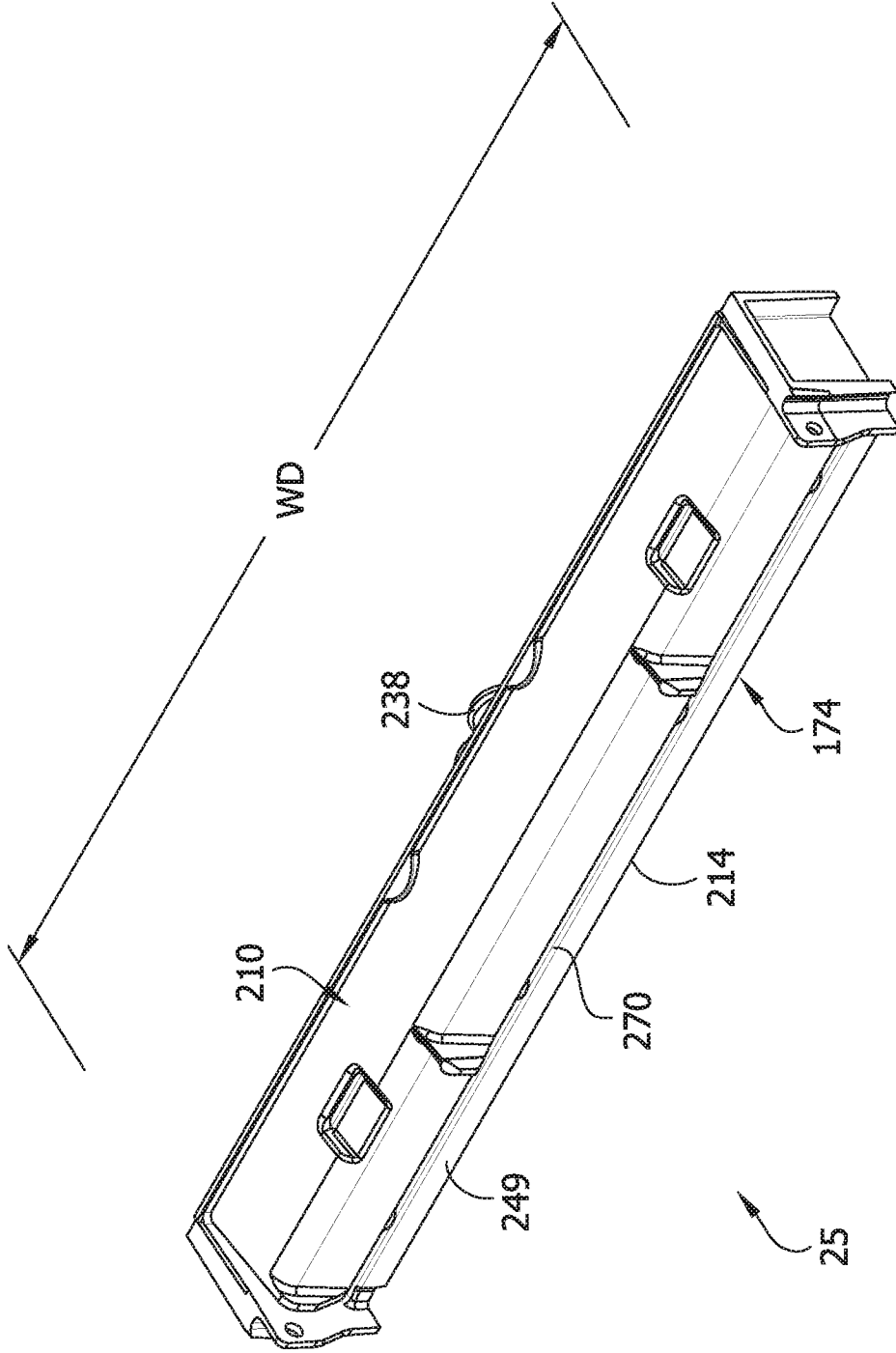

FIG. 18



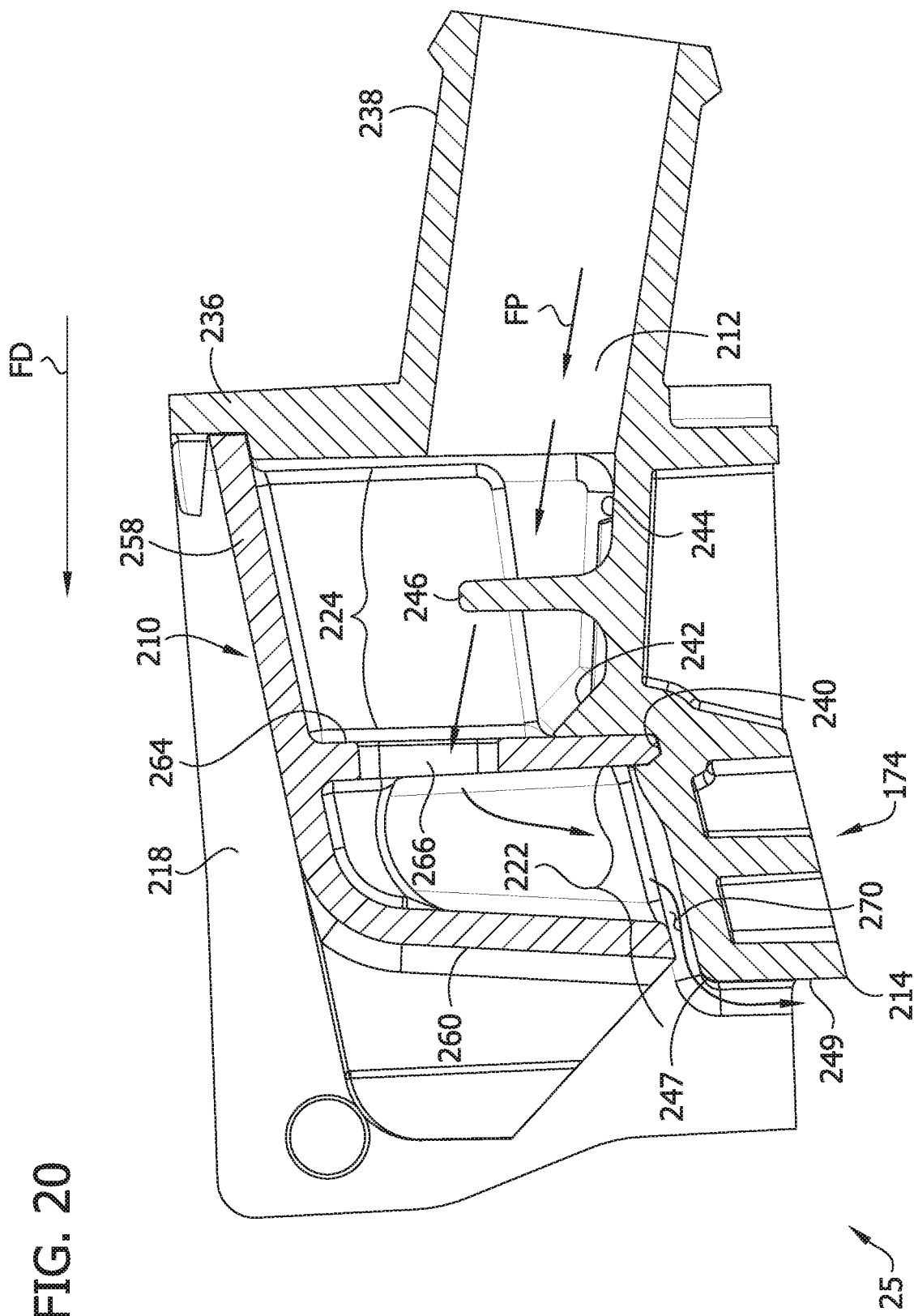
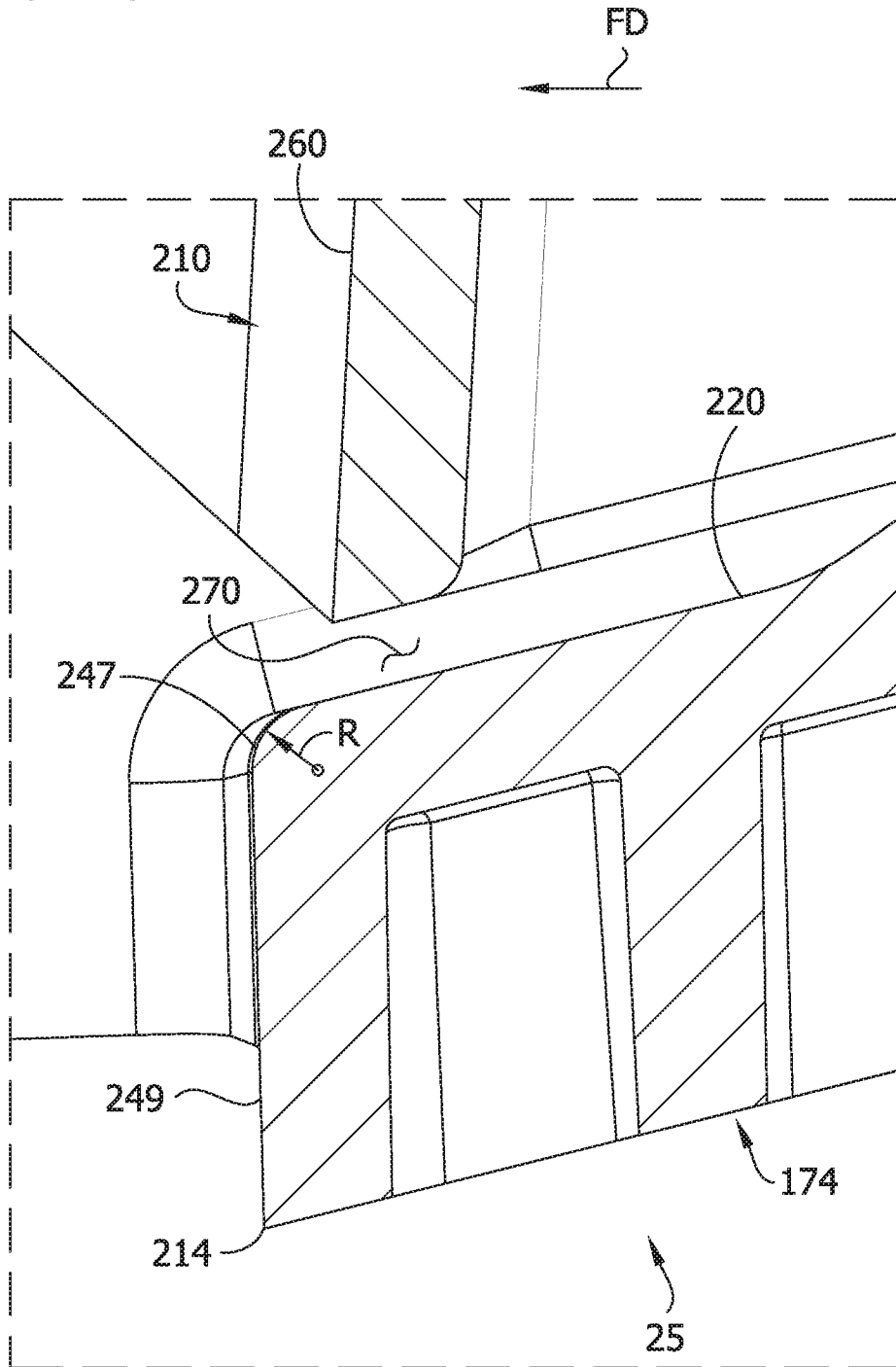

FIG. 20A



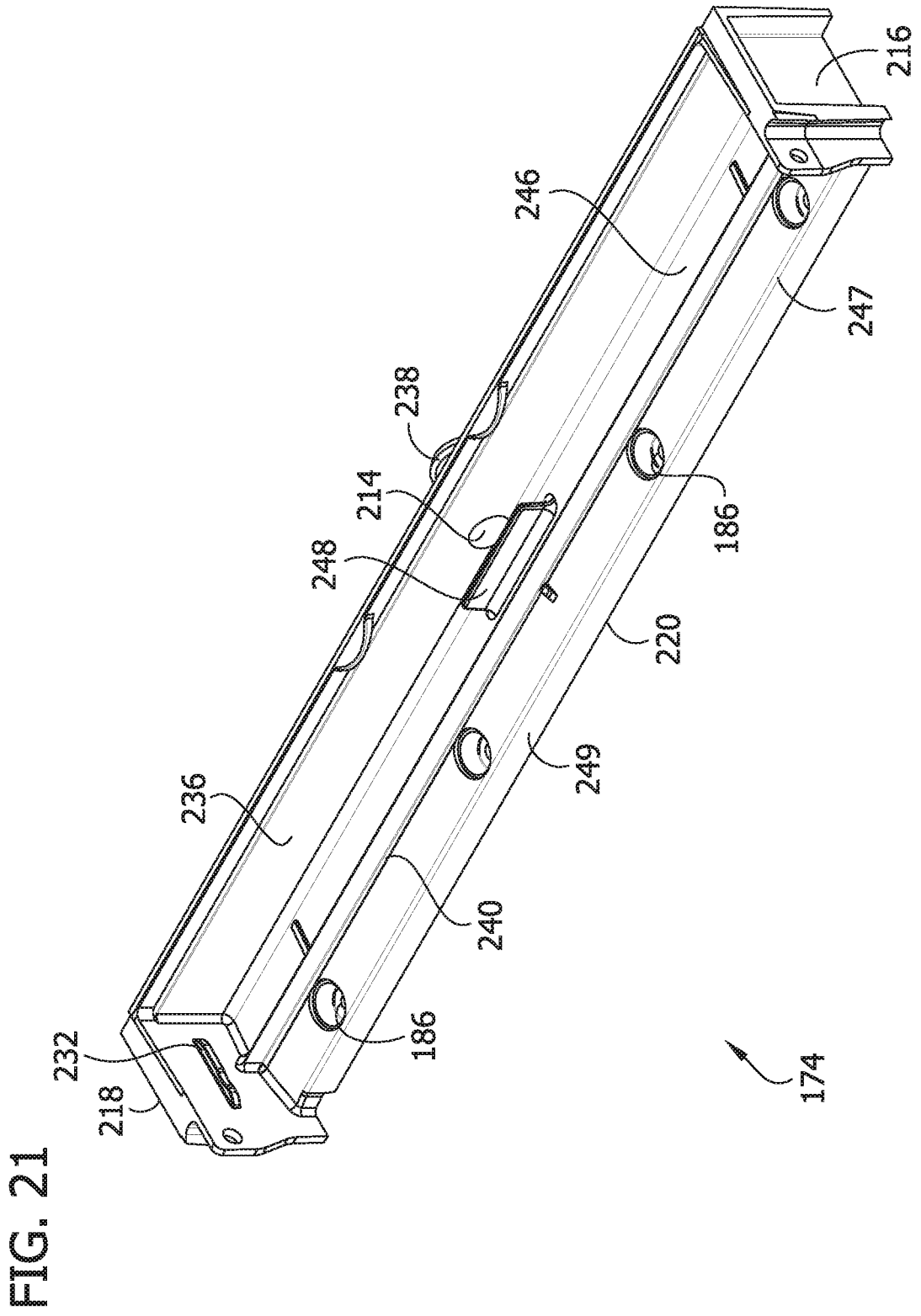

FIG. 22

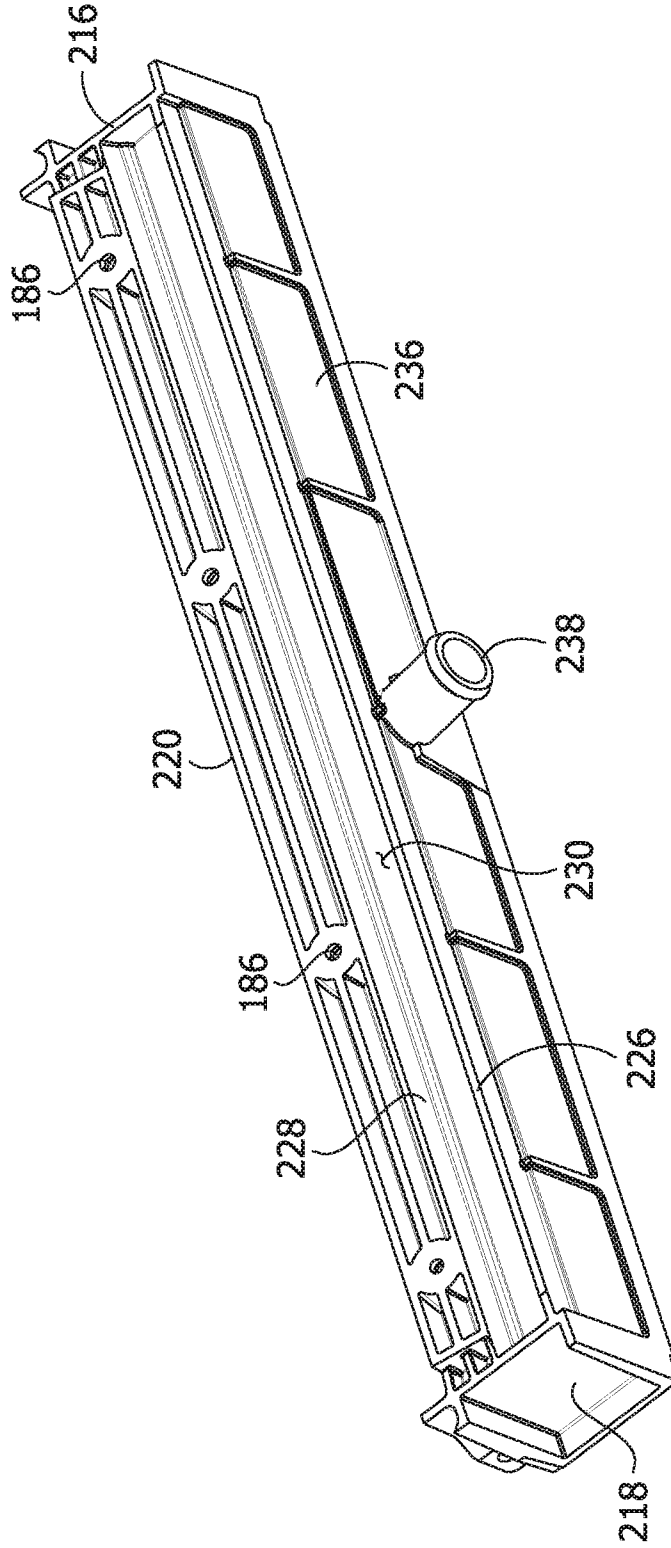

FIG. 23

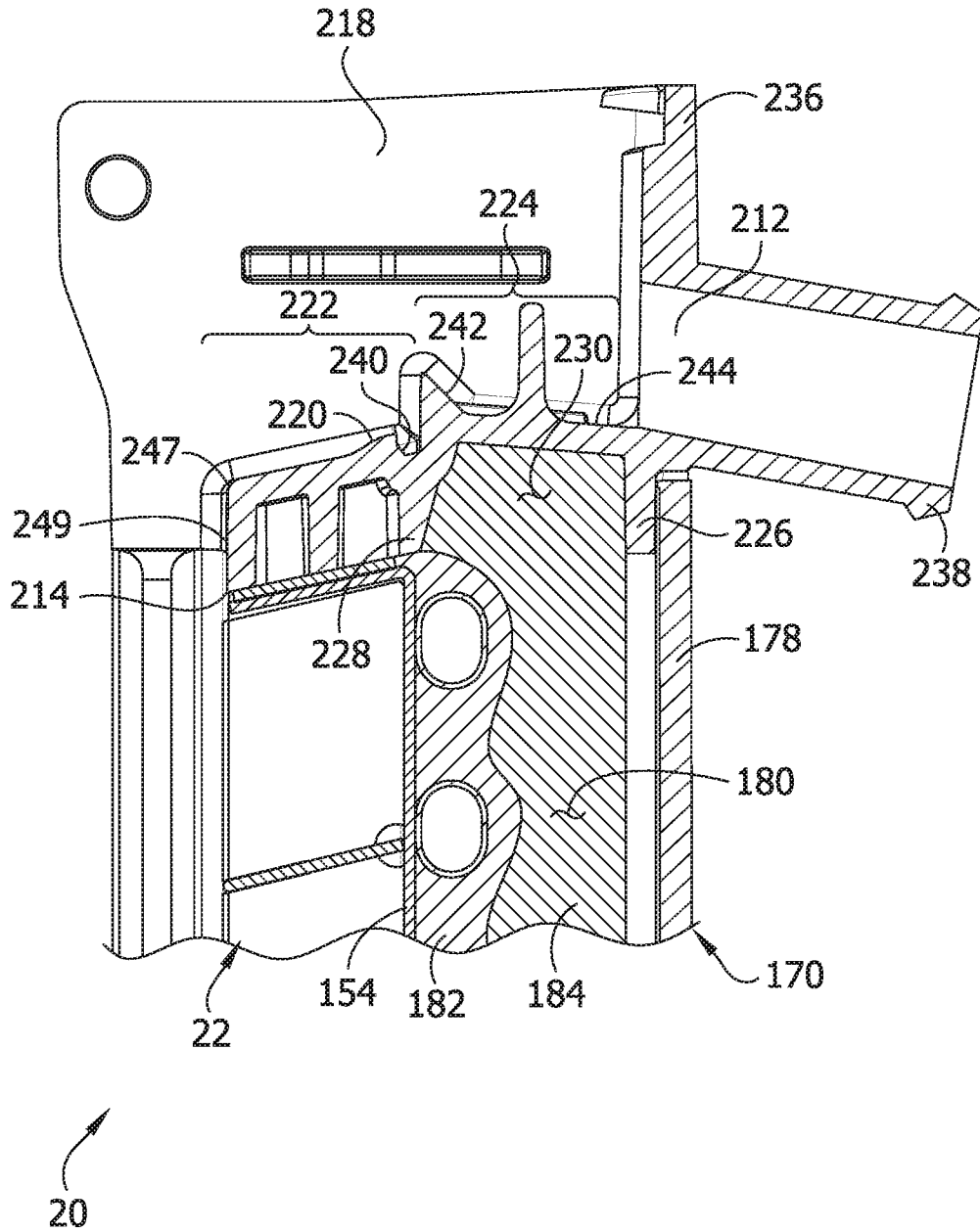

FIG. 24

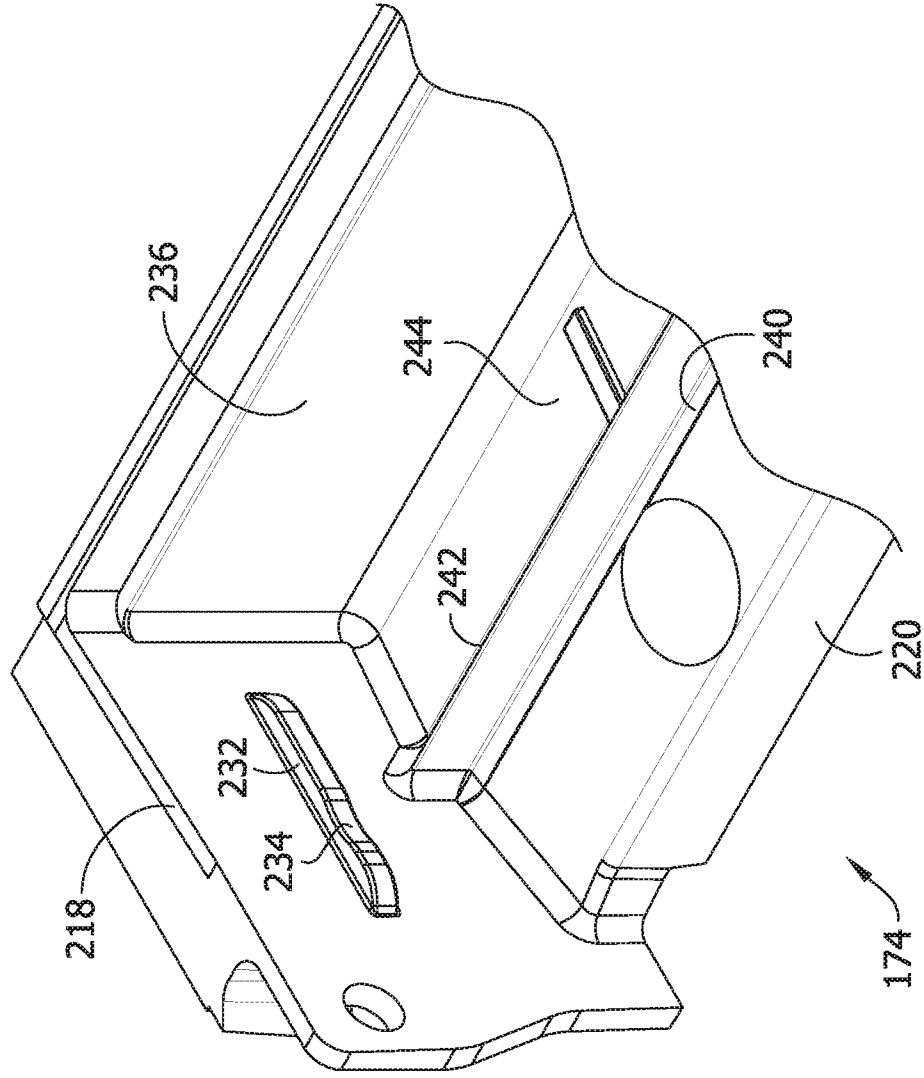

FIG. 25

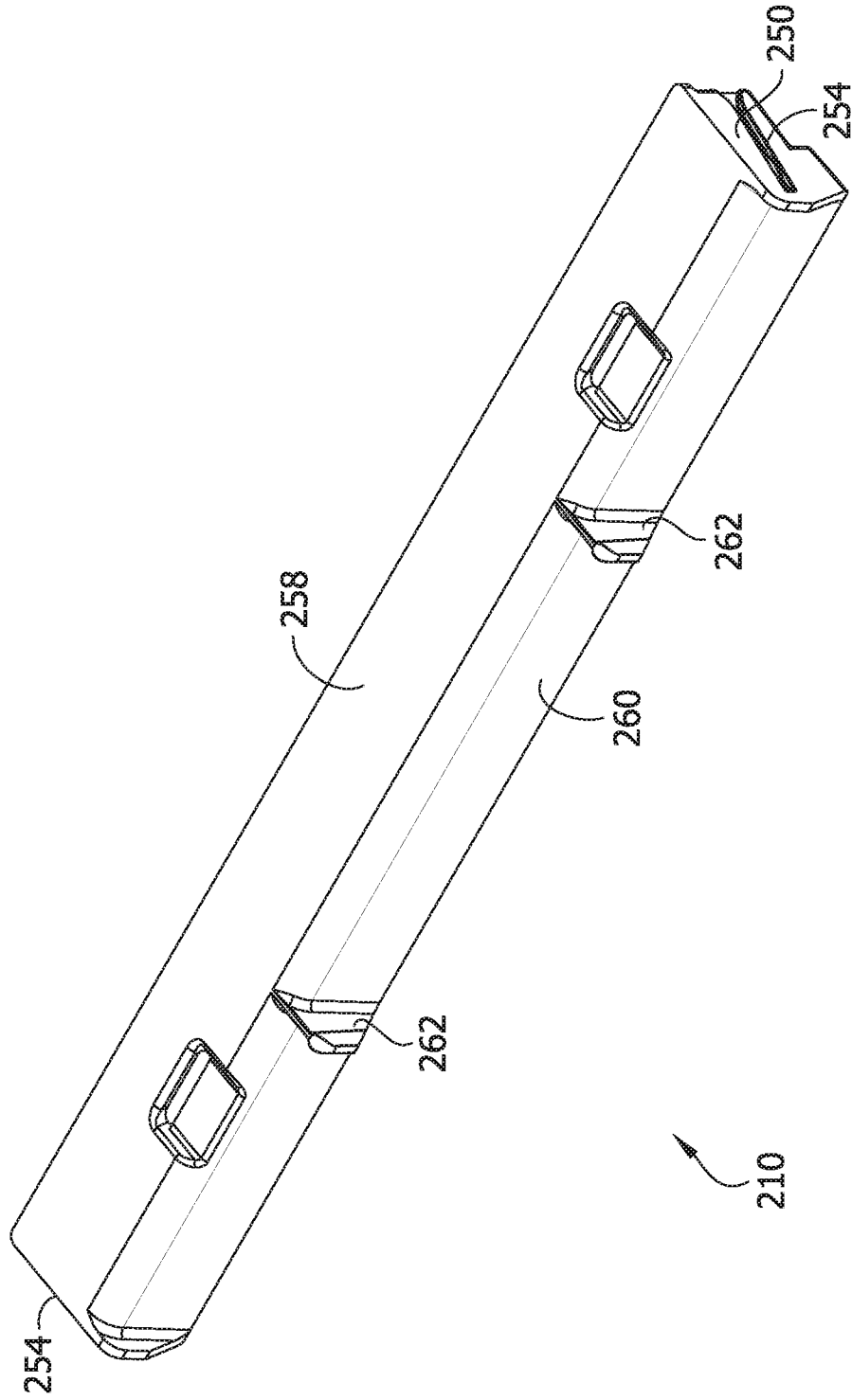

FIG. 26

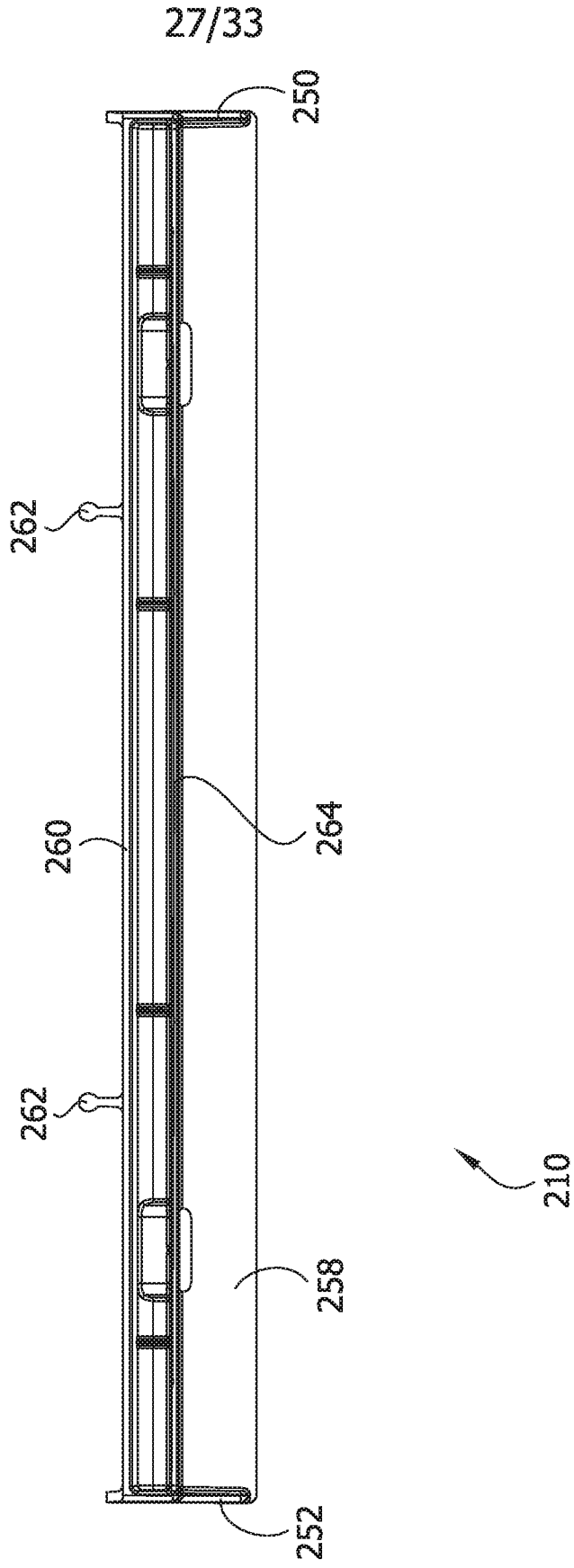

FIG. 27

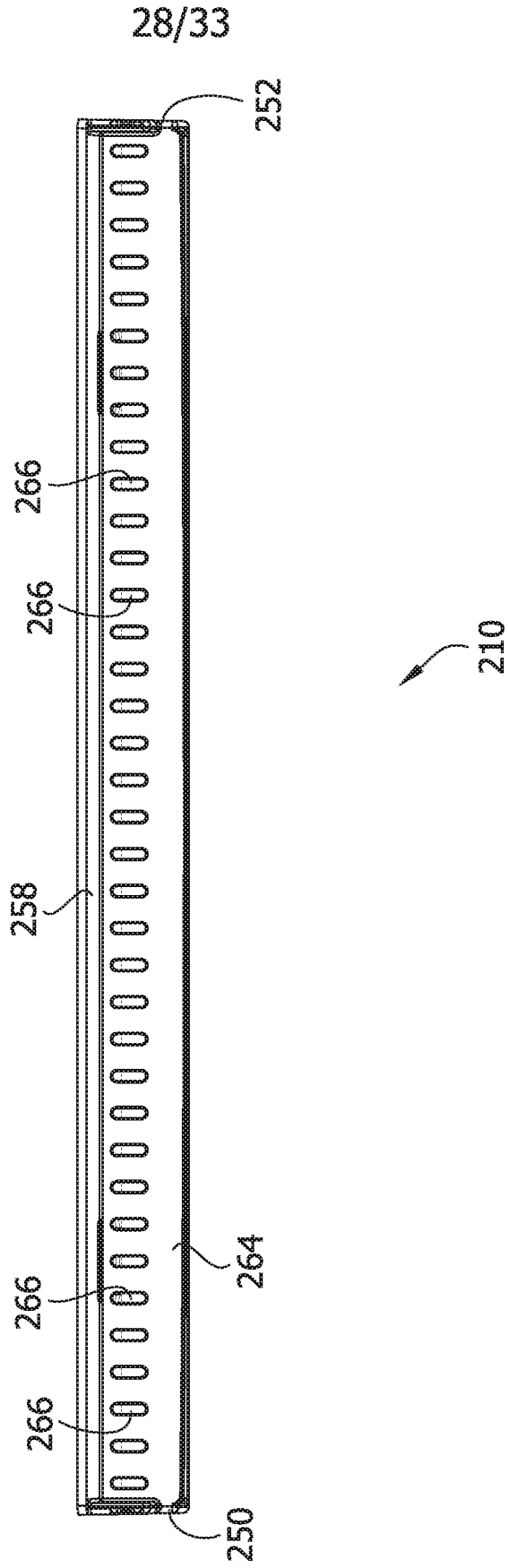
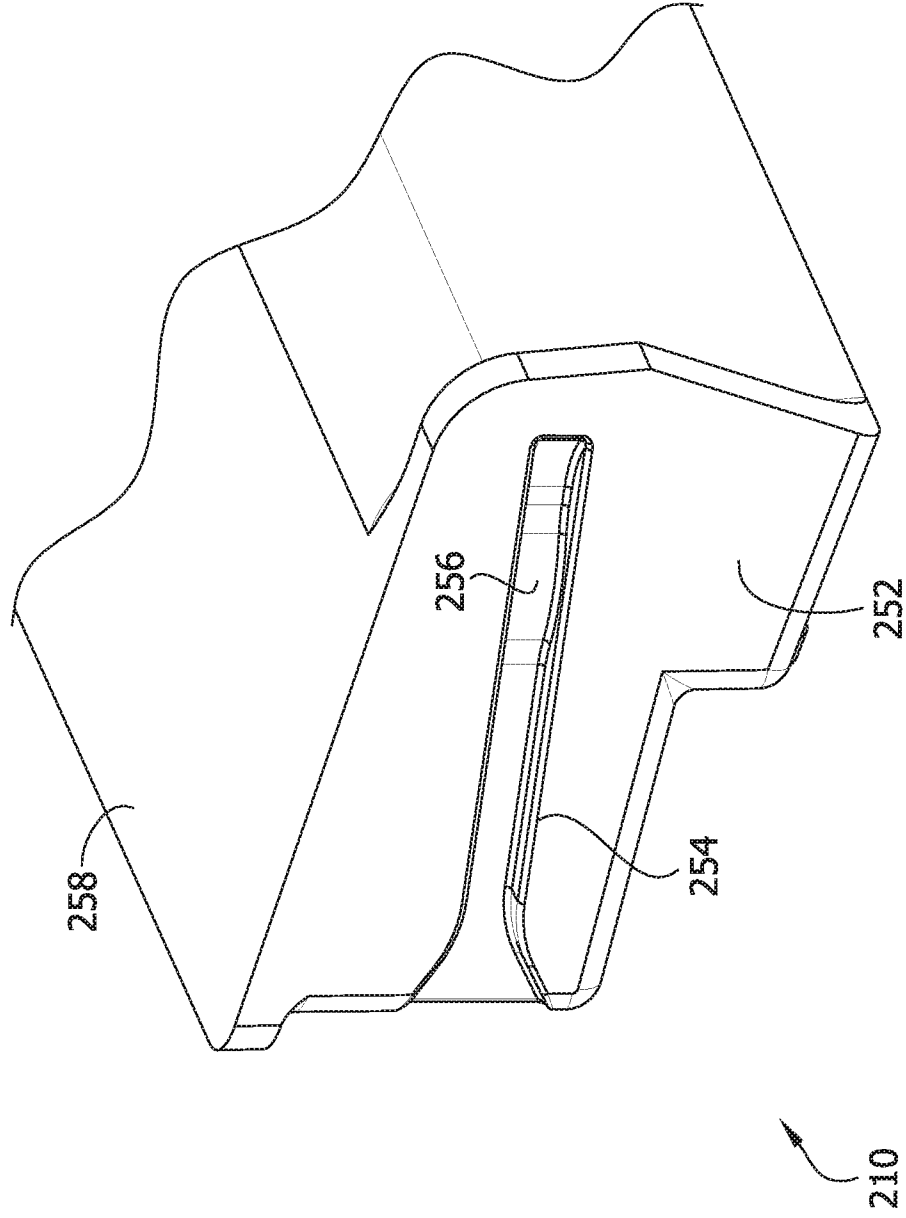

FIG. 28



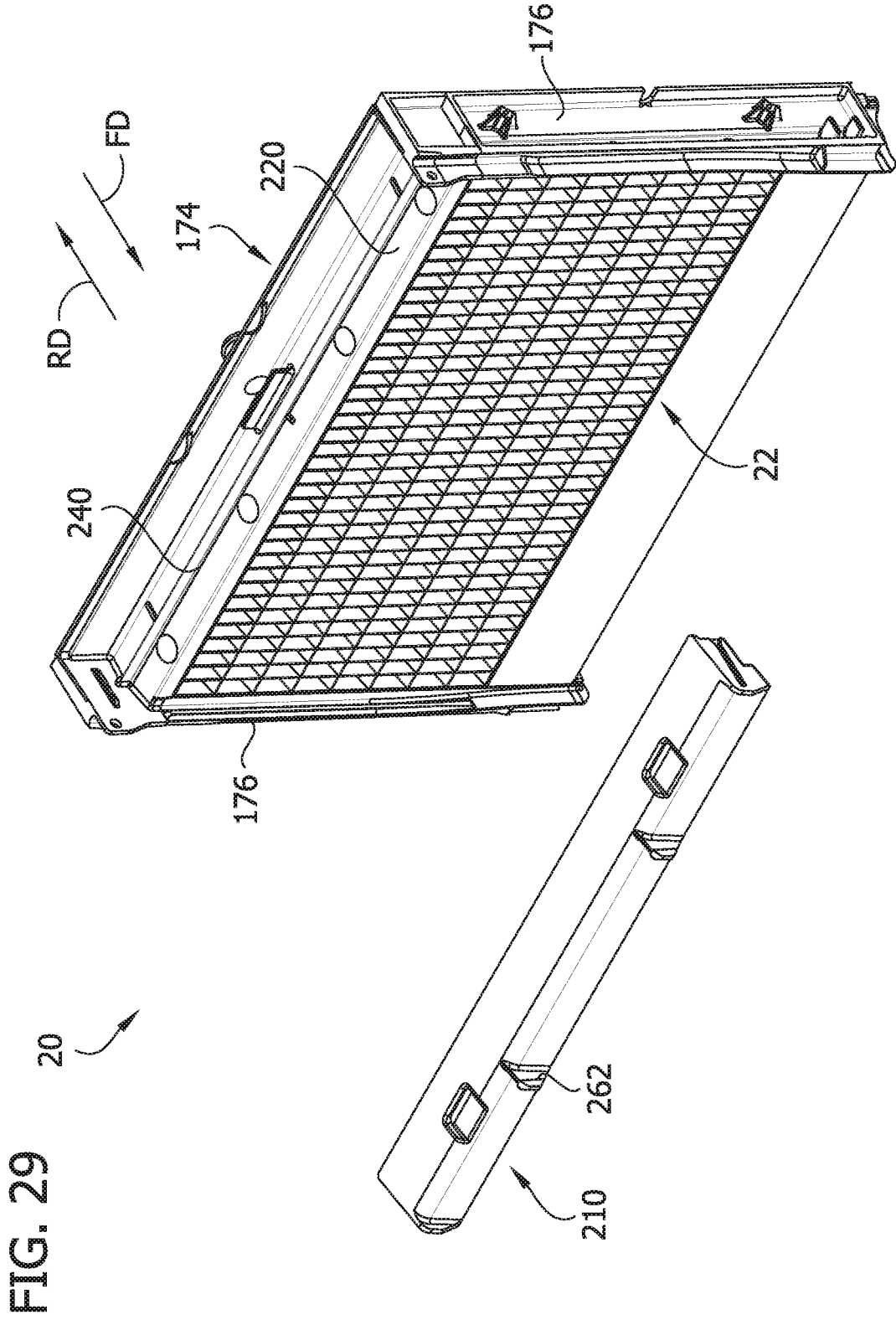

FIG. 31

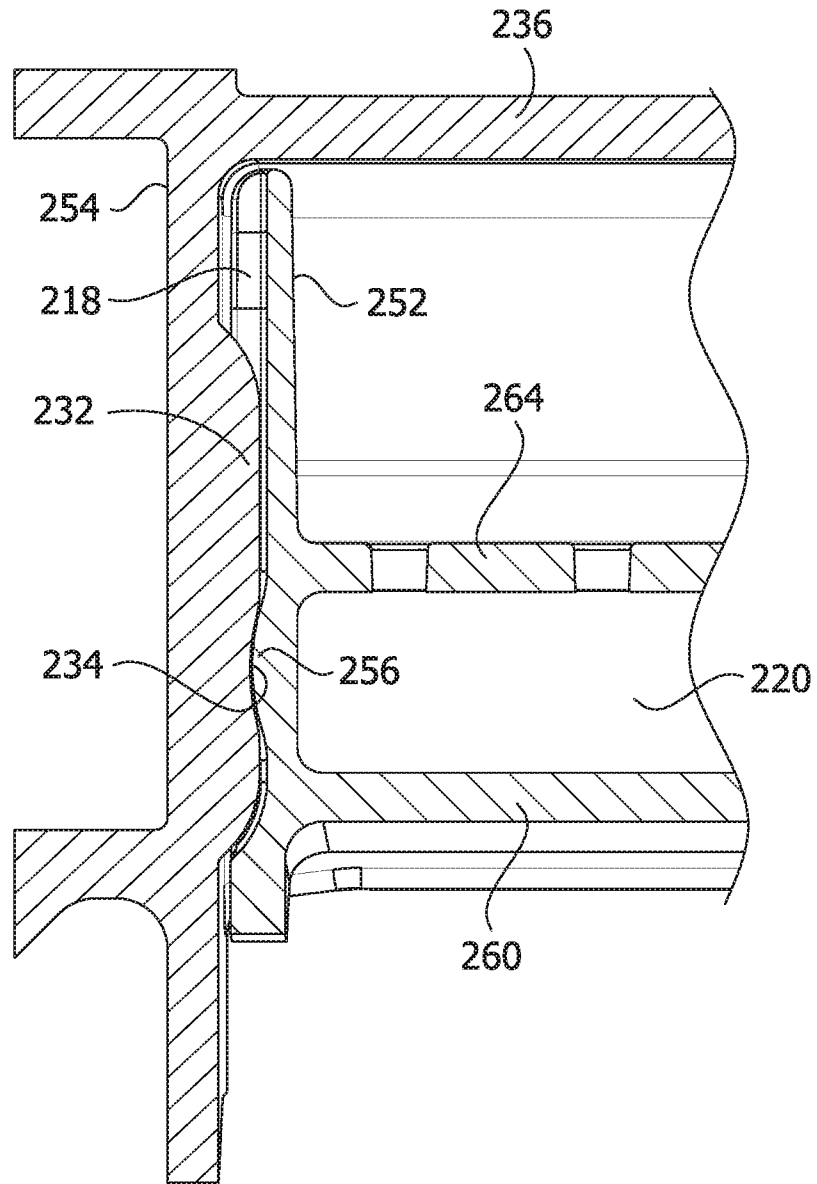

FIG. 32

