



INTERNATIONAL APPLICATION PUBLISHED UNDER THE PATENT COOPERATION TREATY (PCT)

<p>(51) International Patent Classification ⁶ : H01Q 9/30, 1/38, 5/00</p>	<p>A1</p>	<p>(11) International Publication Number: WO 96/38881 (43) International Publication Date: 5 December 1996 (05.12.96)</p>
<p>(21) International Application Number: PCT/US96/08057 (22) International Filing Date: 30 May 1996 (30.05.96) (30) Priority Data: 08/459,235 2 June 1995 (02.06.95) US (71) Applicant: ERICSSON INC. [US/US]; One Triangle Drive, Research Triangle Park, NC 27709 (US). (72) Inventors: HAYES, Gerard, J.; 207 Avercrombie Road, Wake Forest, NC 27587 (US). LAMPE, Ross, W.; 2408 White Oak Road, Raleigh, NC 27609 (US). (74) Agent: LASTOVA, John, R.; Nixon & Vanderhye P.C., 8th floor, 1100 North Glebe Road, Arlington, VA 22201-4714 (US).</p>		<p>(81) Designated States: AL, AM, AT, AU, AZ, BB, BG, BR, BY, CA, CH, CN, CZ, DE, DK, EE, ES, FI, GB, GE, HU, IS, JP, KE, KG, KP, KR, KZ, LK, LR, LS, LT, LU, LV, MD, MG, MK, MN, MW, MX, NO, NZ, PL, PT, RO, RU, SD, SE, SG, SI, SK, TJ, TM, TR, TT, UA, UG, UZ, VN, ARIPO patent (KE, LS, MW, SD, SZ, UG), Eurasian patent (AM, AZ, BY, KG, KZ, MD, RU, TJ, TM), European patent (AT, BE, CH, DE, DK, ES, FI, FR, GB, GR, IE, IT, LU, MC, NL, PT, SE), OAPI patent (BF, BJ, CF, CG, CI, CM, GA, GN, ML, MR, NE, SN, TD, TG).</p> <p>Published <i>With international search report.</i></p>

(54) Title: MULTIPLE BAND PRINTED MONOPOLE ANTENNA

(57) Abstract

A printed monopole antenna (10) is disclosed including a first printed circuit board (12) having a first side (14) and a second side (16), a first monopole radiating element in the form of a conductive trace (18) formed on a side of the first printed circuit board (12), and a second monopole radiating element (20) in the form of a conductive trace positioned adjacent the first monopole radiating element, wherein the first monopole radiating element is resonant within a first frequency band and the second monopole radiating element is resonant within a second frequency band. In order for the first and second radiating elements to be resonant within different frequency bands, the conductive traces for each have different electrical lengths. No direct electrical connection exists between the monopole radiating elements, but the second radiating element dominates at a frequency in which the second radiating element is approximately a half-wavelength so that coupling with the first radiating element occurs. The first and second monopole radiating elements are formed on the same side of the first printed circuit board, separate sides of the first printed circuit board, or on separate printed circuit boards.

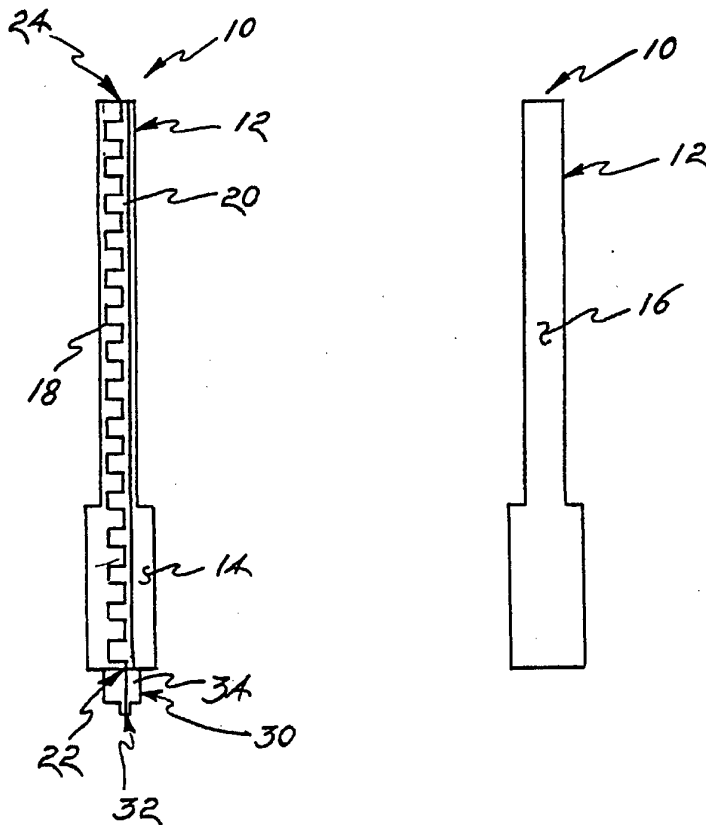

FOR THE PURPOSES OF INFORMATION ONLY

Codes used to identify States party to the PCT on the front pages of pamphlets publishing international applications under the PCT.

AM	Armenia	GB	United Kingdom	MW	Malawi
AT	Austria	GE	Georgia	MX	Mexico
AU	Australia	GN	Guinea	NE	Niger
BB	Barbados	GR	Greece	NL	Netherlands
BE	Belgium	HU	Hungary	NO	Norway
BF	Burkina Faso	IE	Ireland	NZ	New Zealand
BG	Bulgaria	IT	Italy	PL	Poland
BJ	Benin	JP	Japan	PT	Portugal
BR	Brazil	KE	Kenya	RO	Romania
BY	Belarus	KG	Kyrgystan	RU	Russian Federation
CA	Canada	KP	Democratic People's Republic of Korea	SD	Sudan
CF	Central African Republic	KR	Republic of Korea	SE	Sweden
CG	Congo	KZ	Kazakhstan	SG	Singapore
CH	Switzerland	LI	Liechtenstein	SI	Slovenia
CI	Côte d'Ivoire	LK	Sri Lanka	SK	Slovakia
CM	Cameroon	LR	Liberia	SN	Senegal
CN	China	LT	Lithuania	SZ	Swaziland
CS	Czechoslovakia	LU	Luxembourg	TD	Chad
CZ	Czech Republic	LV	Latvia	TG	Togo
DE	Germany	MC	Monaco	TJ	Tajikistan
DK	Denmark	MD	Republic of Moldova	TT	Trinidad and Tobago
EE	Estonia	MG	Madagascar	UA	Ukraine
ES	Spain	ML	Mali	UG	Uganda
FI	Finland	MN	Mongolia	US	United States of America
FR	France	MR	Mauritania	UZ	Uzbekistan
GA	Gabon			VN	Viet Nam

-1-

MULTIPLE BAND PRINTED MONOPOLE ANTENNABACKGROUND OF THE INVENTION5 1. Field of the Invention

The present invention relates to monopole antennas for radiating electromagnetic signals and, more particularly, to a printed monopole antenna including a plurality of radiating elements of
10 different electrical lengths formed adjacent to each other so the monopole antenna is resonant within a plurality of frequency bands.

2. Description of Related Art

15 It has been found that a monopole antenna mounted perpendicularly to a conducting surface provides an antenna having good radiation characteristics, desirable drive point impedance, and relatively simple construction. As a consequence,
20 monopole antennas have been utilized with portable radios, cellular telephones, and other personal communication systems. To date, however, such monopole antennas have generally been limited to wire designs (e.g., the helical configuration in U.S.
25 Patent 5,231,412 to Eberhardt et al.), which operate at a single frequency within an associated bandwidth.

In order to minimize size requirements and permit multi-band operation, microstrip and lamina antennas have been developed for use with certain
30 communication applications. More specifically, U.S. Patent 4,356,492 to Kaloi discloses a microstrip antenna system including separate microstrip radiating elements which operate at different and widely separated frequencies while being fed from a single
35 common input point. However, these radiating elements

-2-

are directly connected with each other and require a ground plane which fully covers the opposite side of a dielectric substrate from such radiating elements. Clearly, this design is impractical for monopole antenna applications, and indeed functions in a completely different manner. Likewise, the lamina antennas disclosed by U.S. Patents 5,075,691 and 4,800,392 to Garay et al. require both a direct connection between radiating elements and a ground plane in order to provide multi-band operation.

Further, U.S. Patent 5,363,114 to Shoemaker discloses a planar serpentine antenna which includes a generally flat, non-conductive carrier layer and a generally flat radiator of a preselected length arranged in a generally serpentine pattern secured to the surface of the carrier layer. One form of this antenna has a sinuous pattern with radiator sections in parallel spaced relation in order to provide dual frequency band operation. However, it is seen that the two frequencies at which resonance takes place involves the length of each radiator section and the total length between first and second ends. While this arrangement is suitable for its intended purpose, it likewise is incapable of operating in the fashion of a monopole antenna.

Accordingly, it would be desirable for a monopole antenna to be developed which not only is operable within more than one frequency band, but also avoids the associated limitations of microstrip and lamina antennas. Further, it would be desirable for a printed monopole antenna to be developed which operates within more than one frequency band and is configured to permit spacing of radiating elements within a single plane.

In light of the foregoing, a primary object

-3-

of the present invention is to provide a monopole antenna which is operable within more than one frequency band.

Another object of the present invention is
5 to provide a monopole antenna which can be constructed within very tight tolerances.

Still another object of the present invention is to provide a printed monopole antenna operable within more than one frequency band.

10 Yet another object of the present invention is to provide a printed monopole antenna which operates as a half-wavelength antenna within a first frequency band and as a quarter-wavelength or half-wavelength antenna within a second frequency band.

15 Another object of the present invention is to provide a monopole antenna which eliminates ground plane requirements found in microstrip and lamina antennas.

Still another object of the present
20 invention is to eliminate direct electric connection between radiating elements of a multi-band antenna.

A further object of the present invention is to provide a printed monopole antenna which can be easily configured for operation at a variety of
25 frequency bands.

These objects and other features of the present invention will become more readily apparent upon reference to the following description when taken in conjunction with the following drawing.

30

SUMMARY OF THE INVENTION

In accordance with one aspect of the present invention, a printed monopole antenna is disclosed including a first printed circuit board having a first
35 side and a second side, a first monopole radiating

-4-

element in the form of a conductive trace formed on a side of the first printed circuit board, and a second monopole radiating element in the form of a conductive trace positioned adjacent the first monopole radiating element. The first monopole radiating element has an electrical length which is resonant within a first frequency band and the second monopole radiating element has an electrical length which is resonant within a second frequency band. In order for the first and second monopole radiating elements to be resonant within different frequency bands, the conductive traces for each have different electrical lengths. No direct electrical connection exists between the monopole radiating elements, but the second radiating element dominates at a frequency in which the second radiating element is approximately a half-wavelength so that coupling with the first radiating element occurs. This particular configuration involves the first and second monopole radiating elements being formed on the same side of the first printed circuit board, but may alternatively involve the second monopole radiating element being formed on the side of the printed circuit board opposite that on which the first monopole radiating element is formed.

In accordance with a second aspect of the present invention, first and second printed circuit boards are provided with each having a first side and a second side, wherein the second printed circuit board second side is positioned adjacent the first printed circuit board first side. A first monopole radiating element in the form of a conductive trace is formed on the first printed circuit board first side, where the first conductive trace has an electrical length which is resonant within a first specified

-5-

frequency band. A second monopole radiating element in the form of a second conductive trace is formed on the second printed circuit board first side, where the second conductive trace has an electrical length which is resonant within a second specified frequency band.

BRIEF DESCRIPTION OF THE DRAWING

While the specification concludes with claims particularly pointing out and distinctly claiming the present invention, it is believed that the same will be better understood from the following description taken in conjunction with the accompanying drawing in which:

Fig. 1. is a schematic left side view of a multiple band printed monopole antenna in accordance with the present invention;

Fig. 2 is a schematic right side view of the multiple band printed monopole antenna depicted in Fig. 1;

Fig. 3 is a schematic view of the multiple band printed monopole antenna depicted in Figs. 1 and 2 mounted on a transceiver after it has been overmolded;

Fig. 4 is a schematic left side view of an alternative embodiment for a multiple band printed monopole antenna in accordance with the present invention; and

Fig. 5 is an exploded, schematic left side view of a second alternative embodiment for a multiple band printed monopole antenna involving more than one printed circuit board.

DETAILED DESCRIPTION OF THE INVENTION

Referring now to the drawings in detail, wherein identical numerals indicate the same elements

-6-

throughout the figures, Figs. 1-3 depict a printed monopole antenna 10 of the type which can be utilized with radio transceivers, cellular phones, and other personal communication equipment having multiple
5 frequency bands of operation. As seen in Figs. 1 and 2, printed monopole antenna 10 includes a printed circuit board 12, which preferably is planar in configuration and has a first side 14 (see Fig. 1) and a second side 16 (see Fig. 2). It will be noted that
10 printed monopole antenna 10 includes a first monopole radiating element in the form of a first conductive trace 18 formed on first side 14 of printed circuit board 12. In addition, a second monopole radiating element in the form of a second conductive trace 20 is
15 formed on first side 14 of printed circuit board 12. Alternatively, second conductive trace 20 may be formed on second side 16 of printed circuit board 12.

More specifically, it will be seen that first conductive trace 18 has a physical length l_1 from
20 a feed end 22 to an opposite open end 24. Likewise, second conductive trace 20 has a physical length l_2 from a first end 26 (adjacent to feed end 22 of first conductive trace 18) and a second end 28 (adjacent to open end 24 of first conductive trace 18). As seen in
25 Fig. 1, it is preferred that first and second conductive traces 18 and 20, respectively, be oriented substantially parallel to each other and the respective physical lengths l_1 and l_2 be substantially equivalent.

30 Due to the non-linear configuration of first conductive trace 18, it will have an electrical length greater than physical length l_1 . This type of conductive trace is explained in greater detail in a patent application entitled "Antenna Having Electrical
35 Length Greater Than Its Physical Length," filed

-7-

concurrently herewith, which is also owned by the assignee of the present invention and hereby incorporated by reference. It will be noted that second conductive trace 20 has a linear configuration so that it has an electrical length substantially equivalent to physical length l_2 . Accordingly, it will be understood that first conductive trace 18 has an electrical length greater than that for second conductive trace 20, whereby first conductive trace 18 will be resonant within a lower frequency band than second conductive trace 20. As seen in Fig. 4, second conductive trace 20 may have a non-linear configuration similar to that of first conductive trace 18, wherein second conductive trace 20 would have an electrical length greater than physical length l_2 thereof. In either event, it will be recognized that first conductive trace 18 will preferably have an electrical length greater than that of second conductive trace 20.

By differentiating the electrical lengths of first and second conductive traces 18 and 20, respectively, printed monopole antenna 10 will be able to operate within first and second frequency bands. Preferably, the first frequency band will be approximately 800 MegaHertz to approximately 1000 MegaHertz while the second frequency band will be approximately 1800 MegaHertz to approximately 2000 MegaHertz. Alternatively, other frequency bands may be utilized for the second frequency band so that printed monopole antenna 10 can communicate with satellites, such as between approximately 1500 MegaHertz and approximately 1600 MegaHertz or between approximately 2400 MegaHertz and 2500 MegaHertz. In order to better accomplish this multi-band operation, it will be understood that first conductive trace 18

-8-

will preferably have an electrical length substantially equivalent to a quarter-wavelength or a half-wavelength of a center frequency within the first frequency band. Correspondingly, second conductive
5 trace 20 will preferably have an electrical length substantially equivalent to a half-wavelength for a center frequency within the second frequency band.

Contrary to prior art antennas, printed monopole antenna 10 requires no direct electrical
10 connection between the first and second monopole radiating elements (first and second conductive traces 18 and 20). Accordingly, second conductive trace 20 will have very little effect on antenna response when first conductive trace 18 is resonant. Moreover, at a
15 higher frequency in which second conductive trace 20 is approximately a half-wavelength thereof, the response of second conductive trace 20 dominates and significant coupling occurs with first conductive trace 18. Since the two responses of first and second
20 conductive traces 18 and 20 are very independent, dual frequency band performance can be obtained by merely adjusting the electrical lengths thereof.

Printed monopole antenna 10 also preferably includes a feed port 30, such as in the form of a
25 coaxial connector, which includes a signal feed portion 32 and a ground portion 34. As best seen in Fig. 1, signal feed portion 32 of feed port 30 is coupled only to first conductive trace 18. By this, it is seen that second conductive trace 20 has no
30 means of receiving a signal other than through the aforementioned coupling with first conductive trace 18. Alternatively, first conductive trace 18 may be coupled to the center conductor of a coaxial connector.

35 With respect to the construction of printed

-9-

monopole antenna 10, it is preferred that first printed circuit board 12 be made of a flexible dielectric material, such as polyamide, polyester, or the like. It is also preferred that first conductive trace 18, second conductive trace 20, and first printed circuit board 12 be overmolded with a low-loss dielectric material, as further described in a patent application entitled "Method of Manufacturing a Printed Antenna," filed concurrently herewith, which is also owned by the assignee of the present invention and hereby incorporated by reference. Printed monopole antenna 10 is schematically depicted in Fig. 3 as being attached in its final form to radio transceiver 40.

15 An alternative configuration for printed monopole antenna 10 is to include a second printed circuit board 36 positioned adjacent to first printed circuit board 12. Second printed circuit board 36 has a first side 38 and a second side (not seen), wherein second conductive trace 20 is formed on second printed circuit board first side 38 instead of on first printed circuit board first side 14 as shown in Fig. 1. It will be understood that second printed circuit board 36 will be positioned adjacent to but a distance from first printed circuit board 12 so that they lie in planes oriented substantially parallel to each other. The distance between first printed circuit board 12 and second printed circuit board 36 is adjusted to maintain a minimum voltage standing wave ratio at a feed point for printed monopole antenna 10. Consistent with the aforementioned embodiment, second printed circuit board 36 also is preferably made of a flexible dielectric material, with first conductive trace 18, second conductive trace 20, first printed circuit board 12, and second printed circuit board 36

-10-

being overmolded.

Having shown and described the preferred embodiment of the present invention, further adaptations of the multiple band printed monopole antenna can be accomplished by appropriate modifications by one of ordinary skill in the art without departing from the scope of the invention. In particular, it will be understood that more than two monopole radiating elements may be utilized with the printed monopole antenna of the present invention, whereby all of such radiating elements may be formed on one side of a single printed circuit board, split between both sides of a single printed circuit board, or allocated between a plurality of printed circuit boards positioned in substantially parallel relationship.

What is claimed is:

-11-

1. A printed monopole antenna, comprising:
- (a) a first printed circuit board having a first side and a second side;
 - (b) a first monopole radiating element
5 comprising a first conductive trace formed on said first printed circuit board first side, said first conductive trace having a physical length from a feed end to an opposite end; and
 - (c) a second monopole radiating element
10 positioned adjacent said first monopole radiating element, said second monopole radiating element comprising a second conductive trace having a physical
15 length from a first end to a second end;

wherein said first monopole radiating element is resonant within a first frequency band and said second monopole radiating element is resonant within a second
20 frequency band.

2. The printed monopole antenna of claim 1, wherein said second conductive trace is formed on said first printed circuit board first side.

3. The printed monopole antenna of claim 1, wherein said second conductive trace is formed on said first printed circuit board second side.

4. The printed monopole antenna of claim 1, wherein said first and second conductive traces are oriented substantially parallel to each other.

5. The printed monopole antenna of claim 1, wherein the physical lengths of said first and second conductive traces are substantially equivalent.

6. The printed monopole antenna of claim 1, wherein said first frequency band is approximately 800 MegaHertz to approximately 1000 MegaHertz.

-12-

7. The printed monopole antenna of claim 1, wherein said second frequency band is approximately 1800 MegaHertz to approximately 2000 MegaHertz.

8. The printed monopole antenna of claim 1, wherein said first conductive trace has an electrical length greater than said physical length of said first conductive trace.

9. The printed monopole antenna of claim 1, wherein said first conductive trace has an electrical length greater than an electrical length of said second conductive trace.

10. The printed monopole antenna of claim 1, wherein said second conductive trace has an electrical length substantially equivalent to said physical length of said second conductive trace.

11. The printed monopole antenna of claim 1, wherein said second conductive trace has an electrical length greater than said physical length of said second conductive trace.

12. The printed monopole antenna of claim 1, wherein said second conductive trace has an electrical length substantially equivalent to a half wavelength for a frequency within said second frequency band.

13. The printed monopole antenna of claim 1, wherein said first conductive trace has an electrical length substantially equivalent to a quarter wavelength for a frequency within said first frequency
5 band.

14. The printed monopole antenna of claim 1, wherein said first conductive trace has an electrical length substantially equivalent to a half wavelength for a frequency within said first frequency band.

15. The printed monopole antenna of claim 1, wherein no direct electrical connection exists between said first and second monopole radiating elements.

-13-

16. The printed monopole antenna of claim 1, further comprising a feed port including a signal feed portion and a ground portion, said signal feed portion being coupled only to said first conductive trace.
17. The printed monopole antenna of claim 16, wherein said feed port comprises a coaxial connector.
18. The printed monopole antenna of claim 1, wherein said first printed circuit board is made of a flexible dielectric material.
19. The printed monopole antenna of claim 2, wherein said first conductive trace, said second conductive trace, and said first printed circuit board are overmolded with a dielectric material.
20. The printed monopole antenna of claim 1, further comprising a second printed circuit board positioned adjacent to said first printed circuit board, said second printed circuit board having a
5 first side and a second side, wherein said second conductive trace is formed on said second printed circuit board first side.
21. The printed monopole antenna of claim 20, wherein said second printed circuit board second side is positioned adjacent said first printed circuit board first side.
22. The printed monopole antenna of claim 20, wherein said first and second printed circuit boards lie in planes oriented substantially parallel to each other.
23. The printed monopole antenna of claim 20, wherein said second printed circuit board is spaced a specified distance from said first printed circuit board to maintain a minimum voltage standing wave
5 ratio at an antenna feed point.
24. The printed monopole antenna of claim 20, wherein said first and second printed circuit boards

-14-

are made of a flexible dielectric material.

25. The printed monopole antenna of claim 20, wherein said first conductive trace, said second conductive trace, said first printed circuit board, and said second printed circuit board are overmolded.

26. A printed monopole antenna, comprising:

(a) a substantially planar printed circuit board having a first side and a second side;

5 (b) a first monopole radiating element comprising a first conductive trace formed on said printed circuit board first side, said first conductive trace having an electrical length so as to be resonant within a first specified
10 frequency band; and

(c) a second monopole radiating element comprising a second conductive trace formed on said printed circuit board
15 first side adjacent said first conductive trace, said second conductive trace having an electrical length so as to be resonant within a second specified frequency band.

27. A printed monopole antenna, comprising:

(a) a substantially planar printed circuit board having a first side and a second side;

5 (b) a first monopole radiating element comprising a first conductive trace formed on said printed circuit board first side, said first conductive trace having an electrical length so as to be
10 resonant within a first specified frequency band; and

-15-

- 15 (c) a second monopole radiating element
comprising a second conductive trace
formed on said printed circuit board
second side adjacent said first
conductive trace, said second
conductive trace having
an electrical length so as to be
resonant within a second specified
20 frequency band.
28. A printed monopole antenna, comprising:
- 5 (a) a first substantially planar printed
circuit board having a first side and a
second side;
- (b) a first monopole radiating element
comprising a first conductive trace
formed on said first printed circuit
board first side, said first conductive
trace having an electrical length so as
10 to be resonant within a first specified
frequency band;
- (c) a second substantially planar printed
circuit board having a first side and a
second side, wherein said second
15 printed circuit board second side is
positioned adjacent said first printed
circuit board first side; and
- (d) a second monopole radiating element
comprising a second conductive trace
20 formed on said second printed circuit
board first side, said second
conductive trace having an electrical
length so as to be resonant within a
second specified frequency band.
29. A printed monopole antenna, comprising:
- (a) a substantially planar printed circuit

-16-

board having a first side and a second side;

- 5 (b) a plurality of monopole radiating elements, each said monopole radiating element comprising a conductive trace formed on one of said printed circuit board sides adjacent each other,
10 wherein each conductive trace has a specified electrical length so as to be resonant within a specified frequency band.

30. The printed monopole antenna of claim 29, wherein said conductive traces are oriented substantially parallel to each other.

31. The printed monopole antenna of claim 29, wherein said conductive traces have substantially equivalent physical lengths.

32. The printed monopole antenna of claim 29, wherein at least one of said conductive traces has a physical length different than said remaining conductive traces.

33. The printed monopole antenna of claim 29, wherein no direct electrical connection exists between said plurality of monopole radiating elements.

34. The printed monopole antenna of claim 29, further comprising a feed port including a signal feed portion and a ground portion, said signal feed portion being coupled to only one of said conductive traces.

35. A printed monopole antenna, comprising:

- (a) a substantially planar first printed circuit board having a first side and a second side;
- 5 (b) a substantially planar second printed circuit board having a first side and a second side, said second side of said

-17-

- 10 second printed circuit board being
positioned adjacent said first side of
said first printed circuit board;
- 15 (c) at least one monopole radiating element
associated with said first printed
circuit board, each of said monopole
radiating elements comprising a
conductive trace formed on said first
printed circuit board first side,
wherein each conductive trace has an
electrical length so as to be resonant
within a specified frequency band; and
- 20 (d) at least one monopole radiating element
associated with said second printed
circuit board, each of said monopole
radiating elements comprising a
conductive trace formed on said second
25 circuit board first side, wherein each
conductive trace has an electrical
length so as to be resonant within a
specified frequency band.

36. The printed monopole antenna of claim 35,
wherein said conductive traces are oriented
substantially parallel to each other.

37. The printed monopole antenna of claim 35,
wherein said conductive traces have substantially
equivalent physical lengths.

38. The printed monopole antenna of claim 35,
wherein at least one of said conductive traces has a
physical length different than said remaining
conductive traces.

39. The printed monopole antenna of claim 35,
wherein no direct electrical connection exists between
said plurality of monopole radiating elements.

40. The printed monopole antenna of claim 35,

-18-

further comprising a feed port including a signal feed portion and a ground portion, said signal feed portion being coupled to only one of said conductive traces.

41. The printed monopole antenna of claim 35, wherein said first and second printed circuit boards lie in planes oriented substantially parallel to each other.

42. The printed monopole antenna of claim 35, wherein said second printed circuit board is spaced a specified distance from said first printed circuit board to maintain a minimum voltage standing wave
5 ratio.

FIG-3

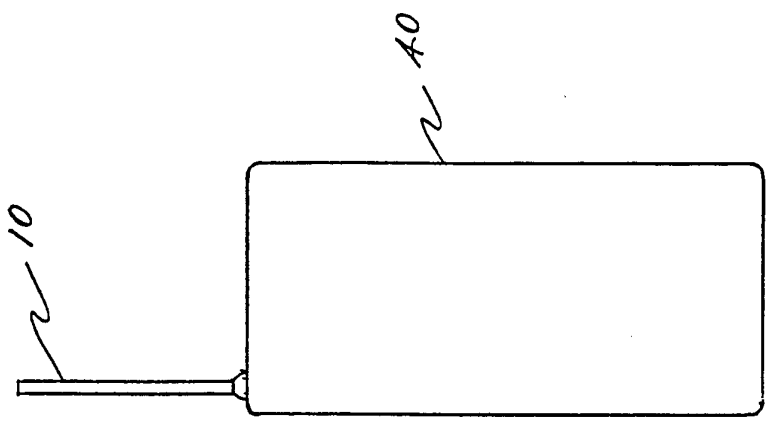

FIG-2

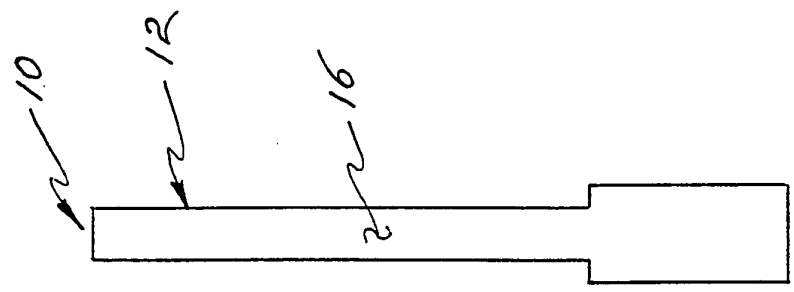
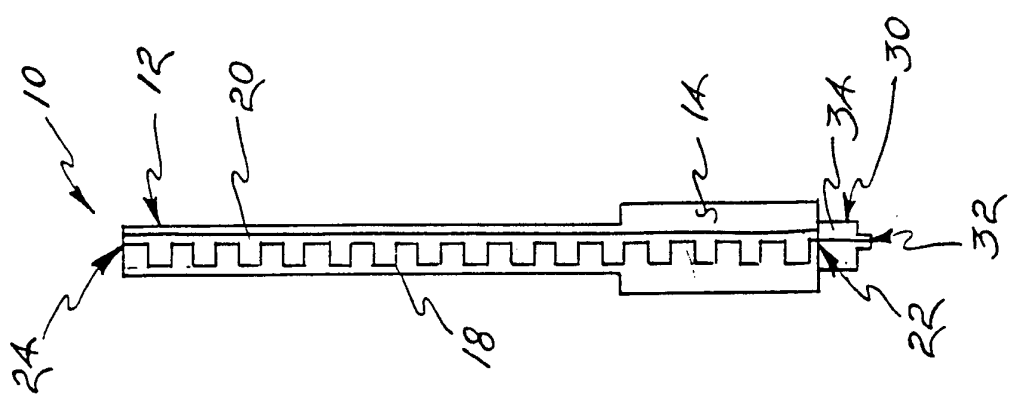
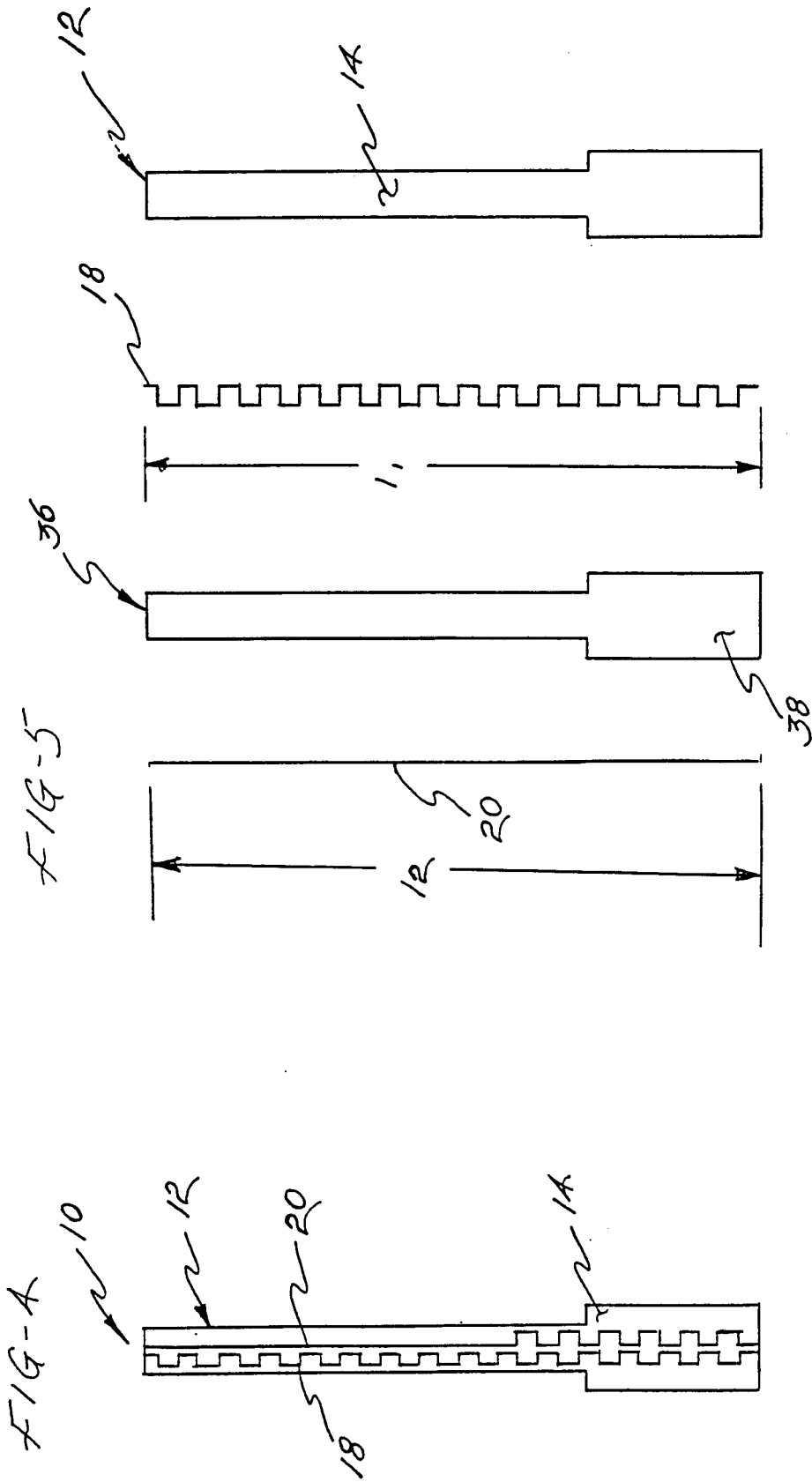

FIG-1





INTERNATIONAL SEARCH REPORT

International Application No
PCT/US 96/08057

A. CLASSIFICATION OF SUBJECT MATTER
IPC 6 H01Q9/30 H01Q1/38 H01Q5/00

According to International Patent Classification (IPC) or to both national classification and IPC

B. FIELDS SEARCHED

Minimum documentation searched (classification system followed by classification symbols)
IPC 6 H01Q

Documentation searched other than minimum documentation to the extent that such documents are included in the fields searched

Electronic data base consulted during the international search (name of data base and, where practical, search terms used)

C. DOCUMENTS CONSIDERED TO BE RELEVANT

Category °	Citation of document, with indication, where appropriate, of the relevant passages	Relevant to claim No.
Y	US,A,4 860 020 (WONG ET AL.) 22 August 1989 see column 2, line 7 - line 17 see column 2, line 55 - column 4, line 67; figures 2-9 ---	1,26-29, 35
Y	US,A,4 849 765 (MARKO) 18 July 1989 see column 2, line 52 - column 3, line 62; figures 1-4 --- -/--	1,26-29, 35

Further documents are listed in the continuation of box C.

Patent family members are listed in annex.

* Special categories of cited documents :

- *"A" document defining the general state of the art which is not considered to be of particular relevance
- *"E" earlier document but published on or after the international filing date
- *"L" document which may throw doubts on priority claim(s) or which is cited to establish the publication date of another citation or other special reason (as specified)
- *"O" document referring to an oral disclosure, use, exhibition or other means
- *"P" document published prior to the international filing date but later than the priority date claimed

- *"T" later document published after the international filing date or priority date and not in conflict with the application but cited to understand the principle or theory underlying the invention
- *"X" document of particular relevance; the claimed invention cannot be considered novel or cannot be considered to involve an inventive step when the document is taken alone
- *"Y" document of particular relevance; the claimed invention cannot be considered to involve an inventive step when the document is combined with one or more other such documents, such combination being obvious to a person skilled in the art.
- *"&" document member of the same patent family

Date of the actual completion of the international search

23 August 1996

Date of mailing of the international search report

13.09.96

Name and mailing address of the ISA
European Patent Office, P.B. 5818 Patentlaan 2
NL - 2280 HV Rijswijk
Tel. (+31-70) 340-2040, Tx. 31 651 epo nl,
Fax (+31-70) 340-3016

Authorized officer

Angrabeit, F

INTERNATIONAL SEARCH REPORT

International Application No
PCT/US 96/08057

C.(Continuation) DOCUMENTS CONSIDERED TO BE RELEVANT		
Category *	Citation of document, with indication, where appropriate, of the relevant passages	Relevant to claim No.
A	<p>CONFERENCE PROCEEDINGS RF EXPO WEST 1995 EMC/ESD, 29 January 1995 - 1 February 1995, SAN DIEGO/CALIFORNIA, pages 117-124, XP000492813 Breed: "Multi-Frequency Antennas For Wireless Applications" see the whole document ---</p>	1-42
A	<p>EP,A,0 590 534 (NTT MOBILE COMMUNICATIONS NETWORK) 6 April 1994 see column 3, line 25 - column 4, line 49; figures 2-7 ---</p>	1,26-29, 35
A	<p>WO,A,94 28595 (GRIFFITH UNIVERSITY) 8 December 1994 see claims 1-5; figures 2-8 -----</p>	1,26-29, 35

INTERNATIONAL SEARCH REPORT

Information on patent family members

International Application No PCT/US 96/08057
--

Patent document cited in search report	Publication date	Patent family member(s)	Publication date
US-A-4860020	22-08-89	NONE	

US-A-4849765	18-07-89	NONE	

EP-A-590534	06-04-94	JP-A- 6112722	22-04-94
		US-A- 5412392	02-05-95

WO-A-9428595	08-12-94	AU-B- 6789194	20-12-94
		EP-A- 0700585	13-03-96
