

(19) World Intellectual Property
Organization
International Bureau



(43) International Publication Date
17 February 2005 (17.02.2005)

PCT

(10) International Publication Number
WO 2005/015693 A1

- (51) International Patent Classification⁷: **H01R 13/60** (74) Agent: FRIEDMAN, Mark; 7 Jabotinsky St., 52520 Ramat Gan (IL).
- (21) International Application Number: PCT/IL2004/000721 (81) Designated States (unless otherwise indicated, for every kind of national protection available): AE, AG, AL, AM, AT, AU, AZ, BA, BB, BG, BR, BW, BY, BZ, CA, CH, CN, CO, CR, CU, CZ, DE, DK, DM, DZ, EC, EE, EG, ES, FI, GB, GD, GE, GH, GM, HR, HU, ID, IL, IN, IS, JP, KE, KG, KP, KR, KZ, LC, LK, LR, LS, LT, LU, LV, MA, MD, MG, MK, MN, MW, MX, MZ, NA, NI, NO, NZ, OM, PG, PH, PL, PT, RO, RU, SC, SD, SE, SG, SK, SL, SY, TJ, TM, TN, TR, TT, TZ, UA, UG, US, UZ, VC, VN, YU, ZA, ZM, ZW.
- (22) International Filing Date: 4 August 2004 (04.08.2004)
- (25) Filing Language: English
- (26) Publication Language: English
- (30) Priority Data: 10/634,871 6 August 2003 (06.08.2003) US
- (71) Applicant (for all designated States except US): M-SYSTEMS FLASH DISK PIONEERS LTD. [IL/IL]; 7 Atir Yeda St., 44425 Kfar Saba (IL).
- (72) Inventor; and
- (75) Inventor/Applicant (for US only): KEDEM, Noam [IL/US]; 826 Wharfside Road, 94404 San Mateo, CA (IL).
- (84) Designated States (unless otherwise indicated, for every kind of regional protection available): ARIPO (BW, GH, GM, KE, LS, MW, MZ, NA, SD, SL, SZ, TZ, UG, ZM, ZW), Eurasian (AM, AZ, BY, KG, KZ, MD, RU, TJ, TM), European (AT, BE, BG, CH, CY, CZ, DE, DK, EE, ES, FI, FR, GB, GR, HU, IE, IT, LU, MC, NL, PL, PT, RO, SE, SI,

[Continued on next page]

(54) Title: CONNECTOR WITH OPPOSITE-FACING PORTS

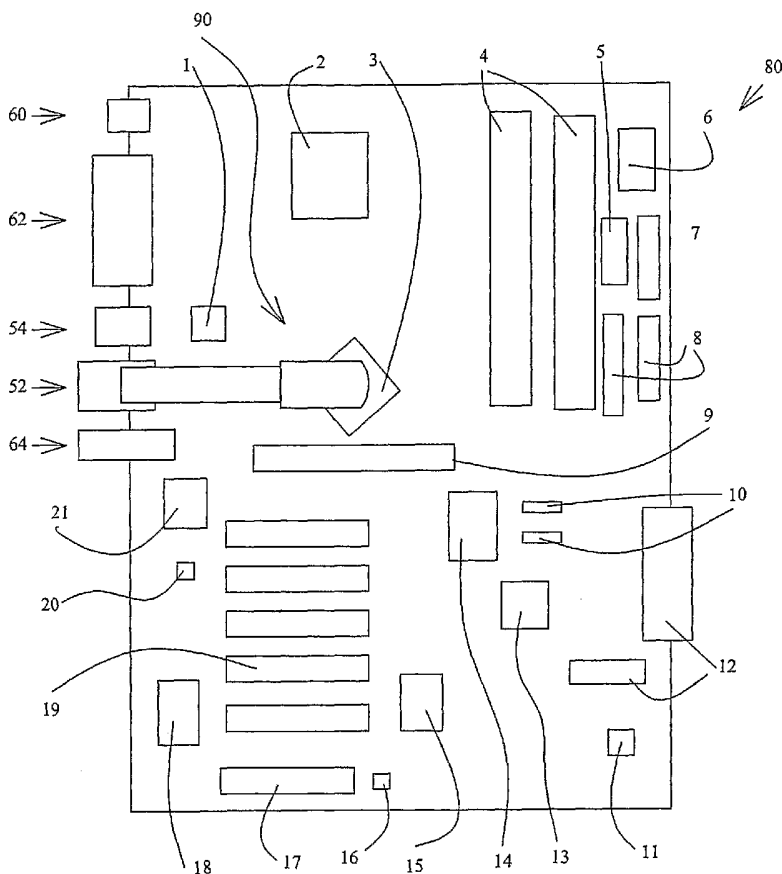

(57) Abstract: A system board (80), including a connector (52) for connecting a host device to one or more peripheral devices including two ports facing in two different directions.

WO 2005/015693 A1



SK, TR), OAPI (BF, BJ, CF, CG, CI, CM, GA, GN, GQ, GW, ML, MR, NE, SN, TD, TG).

For two-letter codes and other abbreviations, refer to the "Guidance Notes on Codes and Abbreviations" appearing at the beginning of each regular issue of the PCT Gazette.

Published:

- *with international search report*
- *before the expiration of the time limit for amending the claims and to be republished in the event of receipt of amendments*

CONNECTOR WITH OPPOSITE-FACING PORTS

FIELD AND BACKGROUND OF THE INVENTION

5 The present invention relates to connectors for connecting peripheral devices to host devices such as computers and, more particularly, to a dual USB connector with opposite-facing ports.

 Figures 1A and 1B are, respectively, top and partial back views of an ASUS P4P800 Deluxe™ motherboard **50**, made by ASUSTeK Computer Inc. of Taipei,
10 Taiwan. Specifically, Figure 1B shows the back plane of motherboard **50**. As described in ASUS P4P800 Deluxe – User Guide, E1323, Revised Edition V3 (ASUSTeK Computer Inc., May 2003), motherboard **50** includes the following components:

- ATX 12V connector **1**
- 15 CPU socket **2**
- North Bridge controller **3**
- Double Data Rate (DDR) Dual In-line Memory Module (DIMM) sockets **4**
- ATX power connector **5**
- Super I/O controller **6**
- 20 Floppy disk connector **7**
- Integrated Drive Electronics (IDE) connectors **8**
- Accelerated Graphics Port (AGP) slot **9**
- Serial Advanced Technology Attachment (ATA) connectors **10**
- Speech controller **11**
- 25 Redundant Arrays of Independent Disks (RAID) Ultra ATA/133 connector **12**
- Flash ROM **13**

- South Bridge controller **14**
- ATA133 RAID controller **15**
- Standby Power LED **16**
- WiFi slot **17**
- 5 1394 controller **18**
- Peripheral Component Interconnect (PCI) slots **19**
- Audio coder/decoder (CODEC) **20**
- Gigabit LAN controller **21**
- PS/2 mouse port **22**
- 10 Parallel port **23**
- Institute of Electrical and Electronic Engineers (IEEE) 1394 port **24**
- Registered Jack (RJ)-45 Ethernet port **25**
- Line-In jack **26**
- Line-Out jack **27**
- 15 Microphone jack **28**
- Four Universal Serial Bus (USB) 2.0 ports **29** and **30**
- Serial port **31**
- Sony/Philips Digital Interface (S/PDIF) output port **32**
- Keyboard port **33**
- 20 USB ports **29** and RJ-45 port **25** are housed in a common connector **52**.
Similarly, USB ports **30** and IEEE 1394 port **24** are housed in a common connector **54**. All four USB ports **29** and **30** face outward, and are suitable for connecting, to a host device such as a computer that is based on motherboard **50**, an external USB

peripheral device with a suitable form factor, such as the DiskOnKey™ flash memory device made by M-Systems Flash Disk Pioneers, Ltd. of Kfar Saba, Israel.

Other connectors in motherboard 50 include a connector 60 that houses PS/2 mouse port 22 and keyboard port 33, a connector 62 that houses parallel port 23, and a
5 connector 64 that houses Line-In jack 26, Line-Out jack 27 and microphone jack 28.

Figure 2 is a line drawing of connector 52 detached from motherboard 50, showing USB ports 29 and RJ-45 port 25 in a common housing 58. Pins 56 at the base of housing 58 are for connecting connector 52 electrically and mechanically to motherboard 50.

10 Because USB ports 29 of connector 52 and USB ports 30 of connector 54 face outward when connectors 52 and 54 are mounted on motherboard 50, only external USB peripheral devices can be connected to motherboard 50, or to a host device such as a computer that is based on motherboard 50, at ports 29 and 30. In particular, a system designer is prevented from incorporating a USB flash memory, such as a
15 DiskOnKey™, as an internal component of motherboard 50.

SUMMARY OF THE INVENTION

The present invention is a connector whose ports face in different directions. In particular, if two ports of the connector face in opposite directions, a system
20 designer is free to use one of the ports, when the connector is mounted on a motherboard, to connect to the motherboard, as an internal peripheral device of a host system based on the motherboard, a device that has the same form factor as a similar device that would connect to the other port as an external peripheral device. Note that in the present context a “port” is understood to be an arrangement, typically but not

necessarily a recess, in the connector, that facilitates a mechanical and electrical connection of the connector to a peripheral device. So, for example, pins 56 at the base of housing 58 of connector 52 are specifically *not* a port as herein understood because pins 56 connect to motherboard 50 and not to a peripheral device.

5 Therefore, according to the present invention there is provided a connector for connecting a host device to at least one peripheral device, including: (a) a first port, facing in a first direction; and (b) a second port, facing in a second direction substantially different from the first direction.

 Preferably, the two ports face in opposite directions.

10 Preferably, the two ports are substantially functionally identical, meaning that both ports provide substantially the same kind of mechanical and electrical connection to the connector. An important special case of this is that in which both ports are USB ports.

 The scope of the present invention also includes a system board that
15 incorporates the connector of the present invention and a host device that incorporates the system board of the present invention. Most commonly, the host device is a computer; but the host device could alternatively be a network router, a TV set top box or a mobile device. Note that the system board of a computer generally is called a “motherboard”, so that in the context of the host device being a computer, the terms
20 “system board” and “motherboard” are synonymous. Preferably, in the system board and in the host device, one of the ports faces inward and the other port faces outward. Most preferably, the system board or the host device also includes an internal peripheral device operationally connected to the inward-facing port.

BRIEF DESCRIPTION OF THE DRAWINGS

The invention is herein described, by way of example only, with reference to the accompanying drawings, wherein:

FIGS. 1A and 1B are top and partial rear views of a prior art motherboard;

5 FIG. 2 is a line drawing of a prior art connector of the motherboard of FIG. 1B;

FIGs. 3A and 3B are line drawings of a connector of the present invention;

FIG. 4 shows a back plane of a motherboard that includes the connector of FIGs. 3A and 3B;

10 FIG. 5 is a top view of the motherboard of FIG. 1A, modified according to the present invention, and with a DiskOnKey™ flash memory connected to the inward-facing USB port.

DESCRIPTION OF THE PREFERRED EMBODIMENTS

15 The present invention is of a connector with ports that face in different directions. Specifically, the present invention can be used to connect one peripheral device to a host device on the inside of the host device while leaving open the option of connecting a second, similar peripheral device to the host device on the outside of the host device.

20 The principles and operation of a connector according to the present invention may be better understood with reference to the drawings and the accompanying description.

Referring again to the drawings, Figures 3A and 3B are line drawings, from opposite sides, of a connector **70** of the present invention. Connector **70** is similar to

connector **52**, sharing with connector **52** RJ-45 port **25** and pins **56** in housing **58**. Instead of two USB ports **29** that face in the same direction as RJ-45 port **25**, connector **70** has one USB port **72** that faces in the same direction as RJ-45 port **25** and another USB port **74** that faces in the opposite direction to RJ-45 port **25**.

5 Figure 4 shows the back plane of a motherboard **80** that is identical to motherboard **50** except for having connector **70** substituted for connector **52**. When connector **70** is mounted on motherboard **80** as shown, USB port **72** faces outward along with RJ-45 port **25** and USB port **74** faces inward.

A system designer of a host device based on motherboard **80** is free to include
10 in his or her design an internal USB peripheral device connected to USB port **74** while leaving USB port **72** free for a user of the host device to connect therewith an external USB peripheral device to the host device. For example, a DiskOnKey™ flash memory could be connected to USB port **74** to serve as one of the non-volatile memories of the host device. Figure 5 shows motherboard **80** with a DiskOnKey™
15 flash memory **90** connected to USB port **74**.

Although it is preferred that USB ports **72** and **74** face in opposite directions as shown, this relative orientation of USB ports **72** and **74** is not an obligatory feature of the present invention. For example, in another embodiment of the connector of the present invention, USB ports **72** and **74** are on two adjacent sides of connector **70** and
20 so are oriented at a 90 degree angle relative to each other. This embodiment could, for example, be mounted on a motherboard in the corner position occupied by connector **60** in motherboards **50** and **80**, to allow two external USB peripheral devices to be mounted on two different sides of a host device that is based on that motherboard.

While the invention has been described with respect to a limited number of embodiments, it will be appreciated that many variations, modifications and other applications of the invention may be made.

WHAT IS CLAIMED IS:

1. A system board comprising a connector that includes:
 - (a) a first port facing outward at an exterior edge of the system board; and
 - (b) a second port, facing inward to an interior of the system board.
2. The system board of claim 2, further comprising a peripheral device operationally connected to said inward-facing port.
3. A host device comprising the system board of claim 2.
4. The host device of claim 3, wherein the host device is a computer.

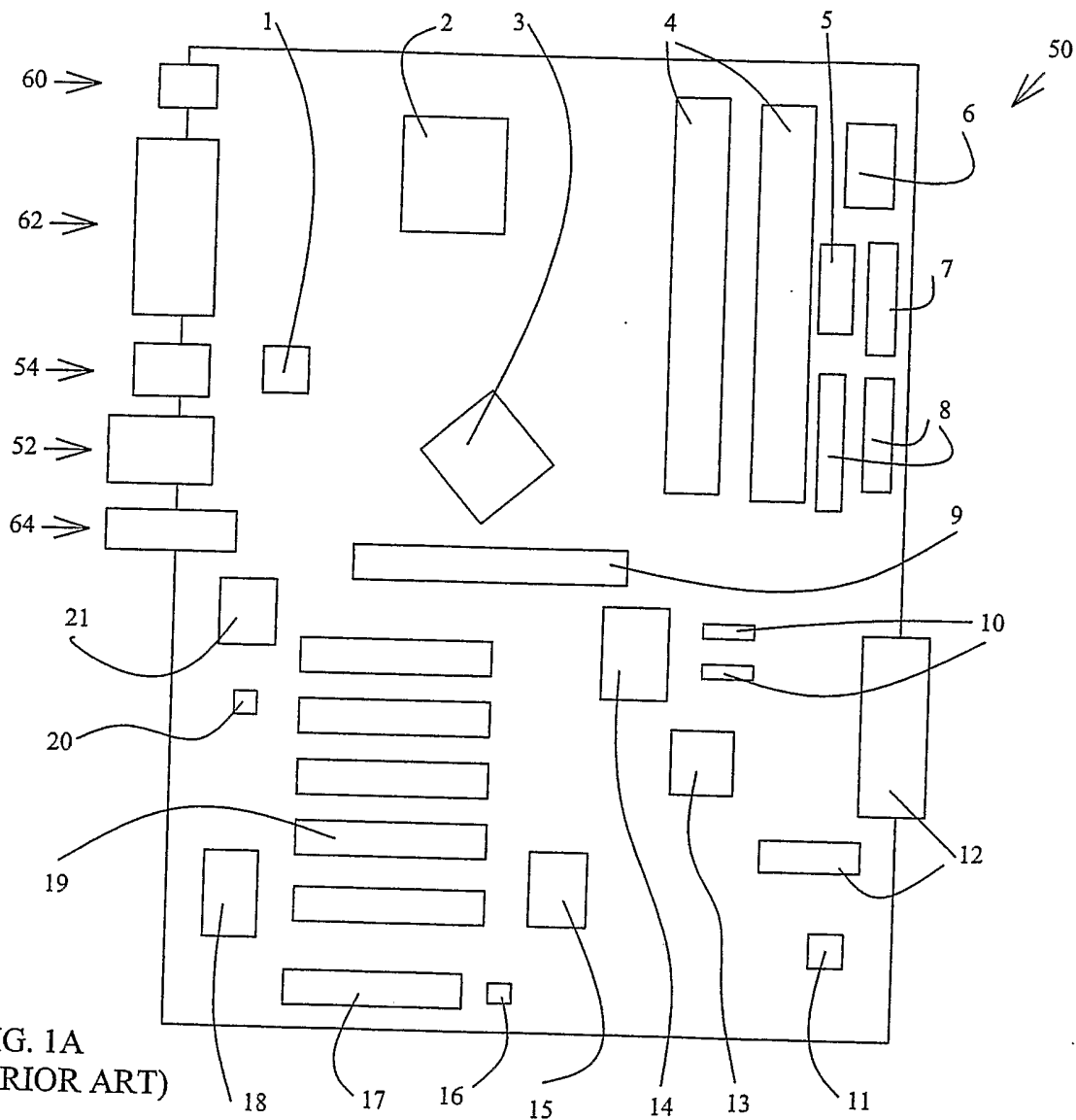

FIG. 1A
(PRIOR ART)

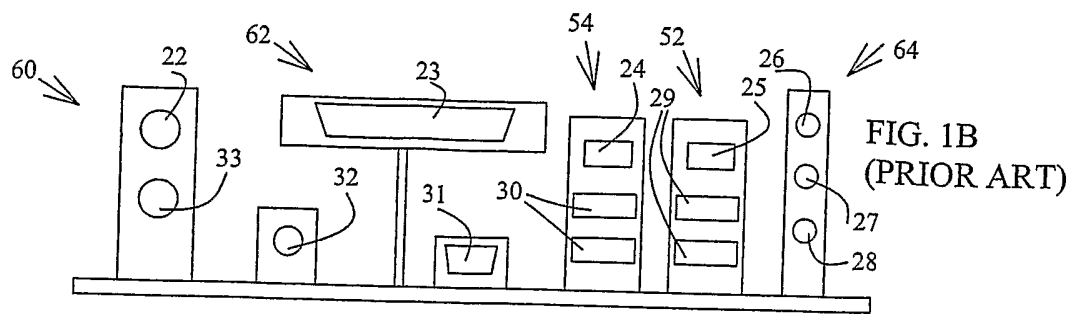

FIG. 1B
(PRIOR ART)

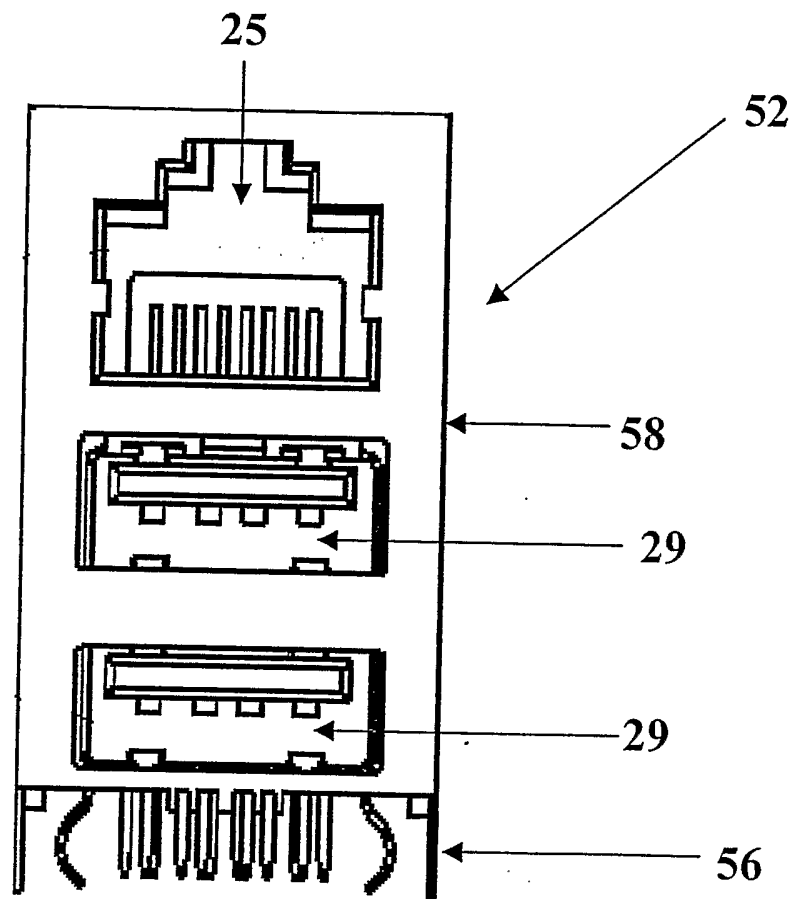

FIGURE 2
(PRIOR ART)

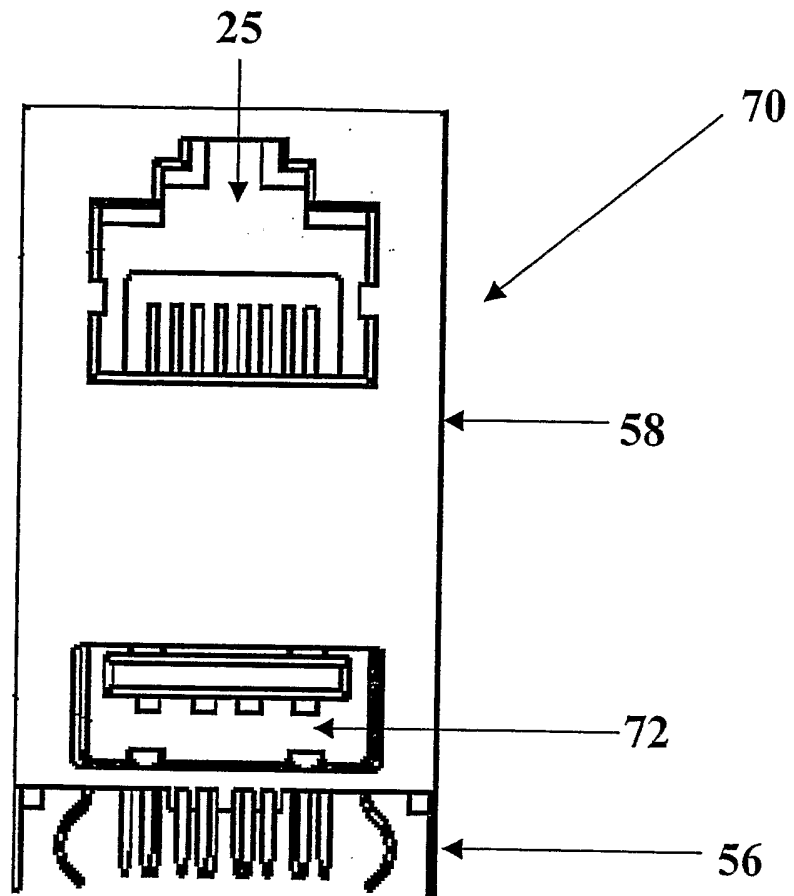

FIGURE 3A

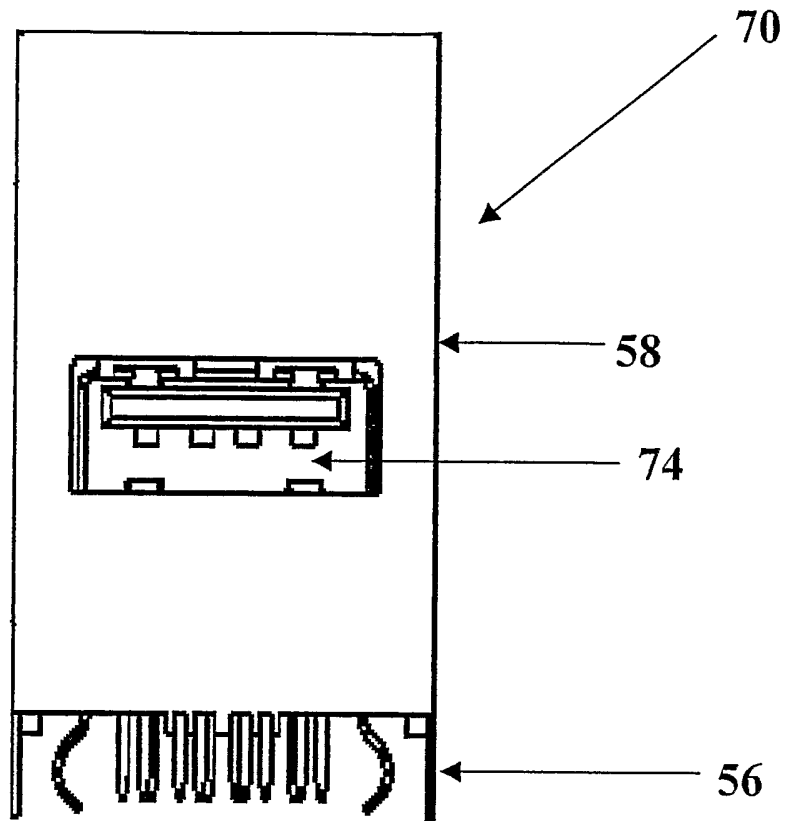

FIGURE 3B

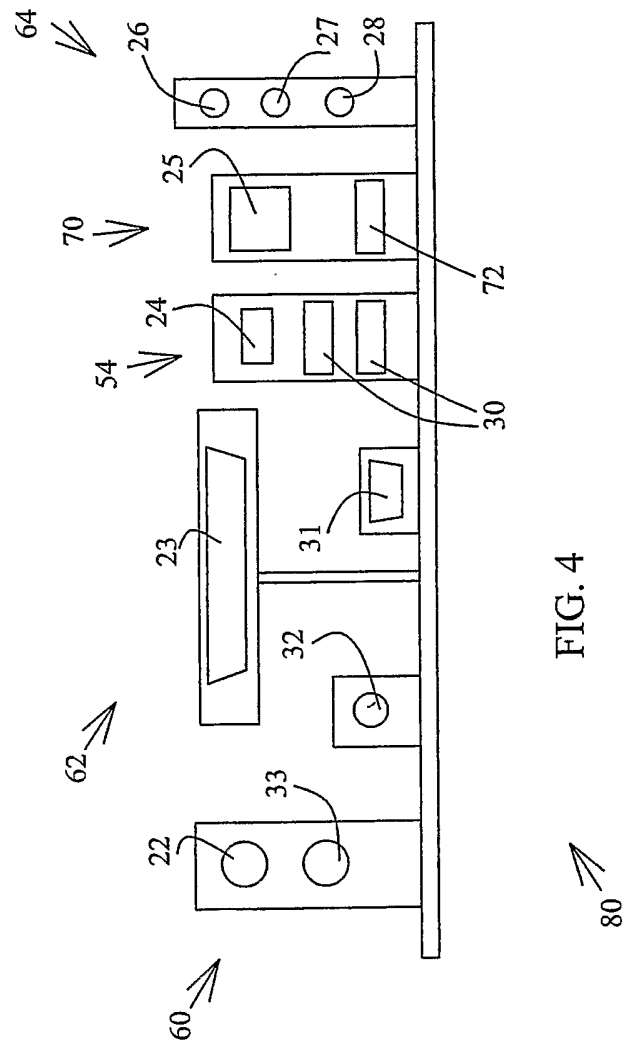

FIG. 4

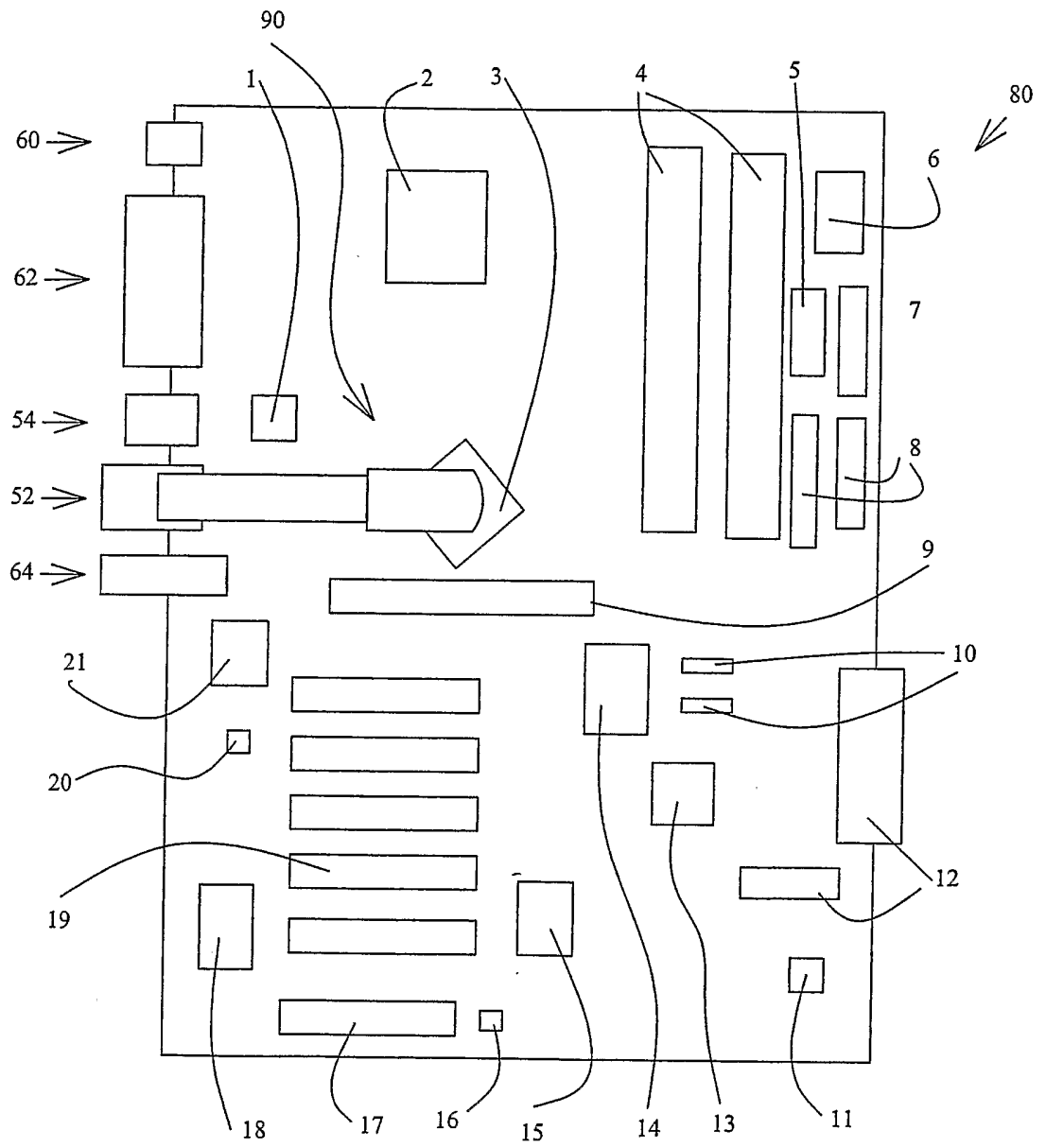

FIG. 5

INTERNATIONAL SEARCH REPORT

International application No.

PCT/IL04/00721

A. CLASSIFICATION OF SUBJECT MATTER IPC(7) : H 01 R 13/60 US CL : 439/541.5 According to International Patent Classification (IPC) or to both national classification and IPC		
B. FIELDS SEARCHED Minimum documentation searched (classification system followed by classification symbols) U.S. : 439/541.5, 79,638,62,217-218,224,954,631,78,676 Documentation searched other than minimum documentation to the extent that such documents are included in the fields searched NONE Electronic data base consulted during the international search (name of data base and, where practicable, search terms used) NONE		
C. DOCUMENTS CONSIDERED TO BE RELEVANT		
Category *	Citation of document, with indication, where appropriate, of the relevant passages	Relevant to claim No.
X	US 2001/0041030 A1 (Chen et al.) 15 Nov. 2001 (15.11.2001), all	1-4
X	US 6,261,107 B1 (Takase et al.) 17 July 2001 (17.07.2001), all	1-4
<input type="checkbox"/> Further documents are listed in the continuation of Box C. <input type="checkbox"/> See patent family annex.		
* Special categories of cited documents:		
"A" document defining the general state of the art which is not considered to be of particular relevance	"T"	later document published after the international filing date or priority date and not in conflict with the application but cited to understand the principle or theory underlying the invention
"E" earlier application or patent published on or after the international filing date	"X"	document of particular relevance; the claimed invention cannot be considered novel or cannot be considered to involve an inventive step when the document is taken alone
"L" document which may throw doubts on priority claim(s) or which is cited to establish the publication date of another citation or other special reason (as specified)	"Y"	document of particular relevance; the claimed invention cannot be considered to involve an inventive step when the document is combined with one or more other such documents, such combination being obvious to a person skilled in the art
"O" document referring to an oral disclosure, use, exhibition or other means	"&"	document member of the same patent family
"P" document published prior to the international filing date but later than the priority date claimed		
Date of the actual completion of the international search		Date of mailing of the international search report
21 October 2004 (21.10.2004)		07 JAN 2005
Name and mailing address of the ISA/US Mail Stop PCT, Attn: ISA/US Commissioner for Patents P.O. Box 1450 Alexandria, Virginia 22313-1450 Facsimile No. (703) 305-3230		Authorized officer Paula A. Bradley <i>Sharon S. Hogg</i> Telephone No. (703) 308-1782