



US 20060084581A1

(19) **United States**

(12) **Patent Application Publication**

**Bragg et al.**

(10) **Pub. No.: US 2006/0084581 A1**

(43) **Pub. Date: Apr. 20, 2006**

(54) **SOLIDS-STABILIZED OIL-IN-WATER EMULSION AND A METHOD FOR PREPARING SAME**

(60) Provisional application No. 60/341,492, filed on Dec. 17, 2001.

(76) Inventors: **James R. Bragg**, Houston, TX (US);  
**Ramesh Varadaraj**, Flemington, NY (US)

Correspondence Address:

**Douglas J. Collins**  
**ExxonMobil Upstream Research Company**  
**P.O. Box 2189**  
**Houston, TX 77252-2189 (US)**

(21) Appl. No.: **11/269,445**

(22) Filed: **Nov. 8, 2005**

**Related U.S. Application Data**

(62) Division of application No. 10/319,752, filed on Dec. 13, 2002, now Pat. No. 6,988,550.

**Publication Classification**

(51) **Int. Cl.**  
**E21B 43/00** (2006.01)  
**C09K 8/74** (2006.01)  
**B01F 3/08** (2006.01)  
**B01F 3/12** (2006.01)  
(52) **U.S. Cl.** ..... **507/269**; 516/53; 516/77

(57) **ABSTRACT**

A solids-stabilized oil-in-water emulsion and a method for preparing the solids-stabilized oil-in-water emulsion. The oil-in-water emulsion is formed by combining oil, water, solid particles and a pH enhancing agent and mixing until the solid-stabilized oil-in-water emulsion is formed. The low viscosity oil-in-water emulsion can be used to enhance production of oil from subterranean reservoirs. The low viscosity oil-in-water emulsion can also be used to enhance the transportation of oil through a pipeline.

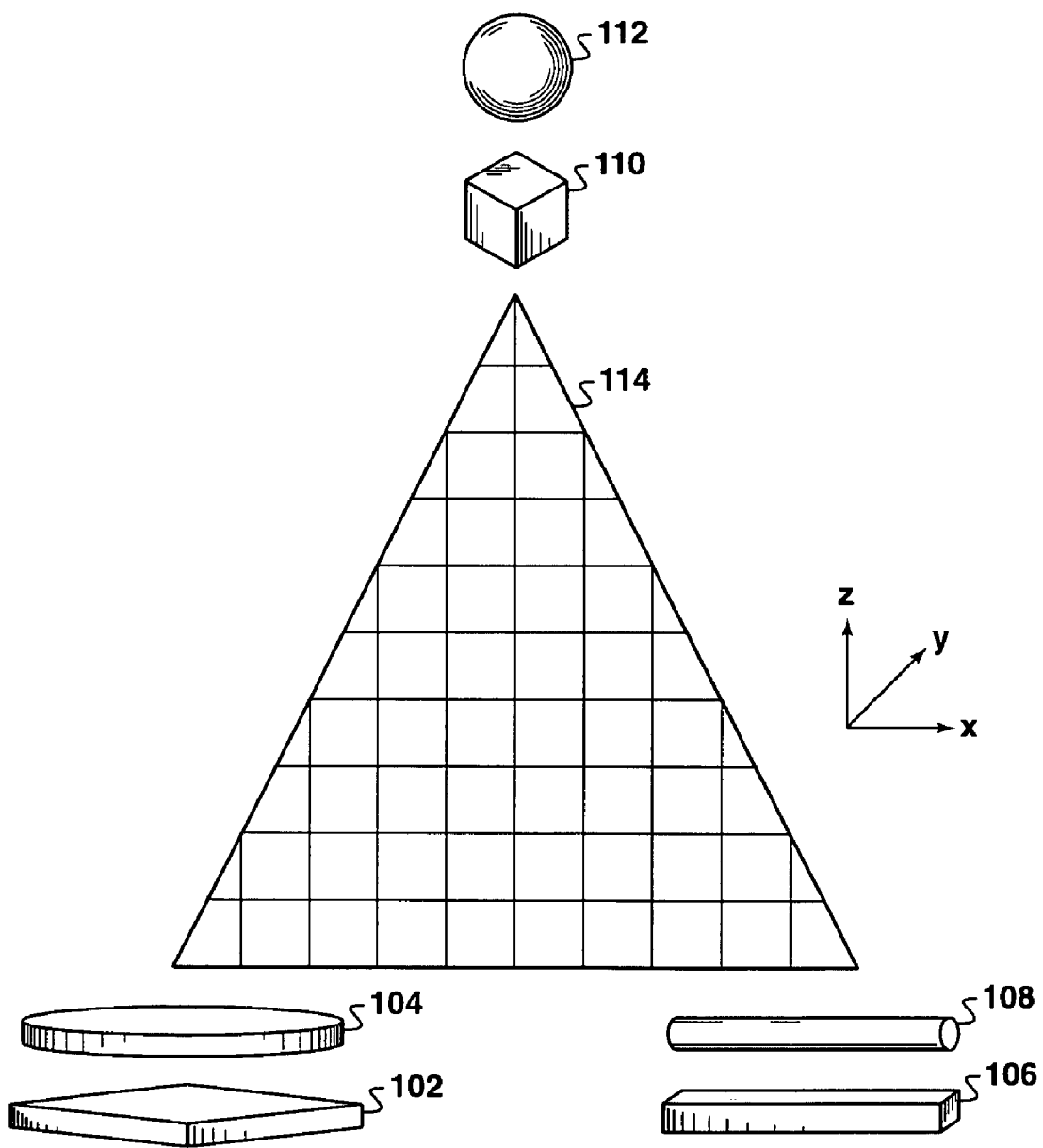

## SOLIDS-STABILIZED OIL-IN-WATER EMULSION AND A METHOD FOR PREPARING SAME

### CROSS-REFERENCE TO RELATED APPLICATIONS

[0001] This application is a divisional of co-pending U.S. application Ser. No. 10/319,752, filed Dec. 13, 2002, which claims the benefit of U.S. Provisional Application No. 60/341,492 filed Dec. 17, 2001.

### FIELD OF INVENTION

[0002] This invention relates to a solids-stabilized oil-in-water emulsion and a method for preparing same. In particular, the invention relates to a method for reducing the effective viscosity of oil by incorporating the oil into a solids-stabilized oil-in-water emulsion.

### BACKGROUND OF INVENTION

[0003] Recovery of oil from a reservoir usually results in simultaneous production of water with the oil. In many cases the oil and water are subject to mixing and shearing in subsurface pumps, and this results in the formation of water-in-oil or oil-external emulsions having a viscosity that is substantially higher than that of the original, "dry oil". Because of wellbore hydraulics, the production of this oil-external emulsion, with its higher viscosity, increases lifting costs (larger pumps and more electrical power requirements) and often limits the production rate from the well, which reduces economic profitability. Often, demulsifier chemicals are added to the subterranean formation to either prevent emulsion formation or to break the oil-external, high viscosity emulsion. The added demulsifier chemicals are expensive specialty products and need to be customized to the oil, emulsion and reservoir characteristics in order for the desired performance to be achieved. What is needed is a simple, economic method for reducing the viscosity of the oil-water mixture.

[0004] Moreover, in some cases the original oil is so viscous, such as with some heavy oils, that even if no water is produced from the reservoir and no oil-external emulsion is formed, the production rate of the oil is nonetheless limited because of its high viscosity. Accordingly, a simple, economic method for reducing the effective viscosity of highly viscous oil is also needed.

[0005] A related problem in the production of oil is a need to obtain an increased flowrate of the oil through a pipeline, for example, a pipeline used to transport oil from the point of production to points of collection, transportation, or sale. The viscosity of the oil is a limiting factor in the efficient transportation of oil. As the viscosity of the oil increases, so do the related costs of transportation, such as pumping costs. Existing methods for increasing pipeline capacity are to heat the oil, dilute the oil with less-viscous hydrocarbon diluents, treat the oil with drag reducers, transport the oil in a core annular flow, or convert the oil into an oil-in-water (or water-external) emulsion having a viscosity lower than that of the dry oil. Methods for making water-external emulsions include adding expensive surfactants or adding surfactants simultaneously with raising the pH of the water-oil mixture by adding base such as sodium hydroxide or ammonium hydroxide. However, for many oils, these treatments do not result in emulsions that remain sufficiently stable for the

long times needed to transport the oil to market. A need exists for an inexpensive method for making a water-external emulsion that remains stable for long periods of time, and can be easily and economically demulsified and separated into the constituent oil and water.

### SUMMARY OF INVENTION

[0006] This invention is a solids-stabilized oil-in-water emulsion, and a method for preparing a solids-stabilized oil-in-water emulsion.

[0007] In an embodiment of the invention, the solids-stabilized oil-in-water emulsion is used to enhance the production of oil from a subterranean reservoir.

[0008] In another embodiment of the invention, the solids-stabilized oil-in-water emulsion is used to enhance the transportation of oil through pipelines.

### BRIEF DESCRIPTION OF THE DRAWINGS

[0009] **FIG. 1** is a ternary diagram that illustrates some, but not all, of the particle shapes that could be characteristic of the solid particles used to make the solids-stabilized oil-in-water emulsion of this invention.

### DETAILED DESCRIPTION OF THE INVENTION

[0010] This invention provides a solids-stabilized oil-in-water emulsion and a method of making a solids-stabilized oil-in-water emulsion. To make a solids-stabilized oil-in-water emulsion pursuant to this invention, solid particles and a pH enhancing agent are added to water and mixed with oil until the solids-stabilized oil-in-water emulsion is formed.

[0011] The solid particles useful for this invention should have certain physical properties. If the solid particles are to be used in a porous subterranean formation, as will be explained in more detail, the average particle size should be smaller than the average diameter of the pore throats in the porous subterranean formation. At least one size measurement dimension of the actual individual particle size should be sufficiently small to provide adequate surface area coverage of the droplets of oil that are formed within the external water phase. Particle size can be measured by a wide array of particle size analytical techniques, including laser light scattering, mesh screen classification, Coulter counting method, and settling velocity (which uses Stokes law to convert a solid sample's settling velocity in a fluid to an average particle size). However, each of these techniques produces an "effective" particle diameter, which is the result that would have been produced by corresponding test sample comprised of particles with a spherical shape. Consequently, a particle's effective diameter becomes a less accurate approximation of its true size as the particle's shape deviates further from a spherical shape. In most instances, however, particles are often irregular and nonuniform in shape.

[0012] Without intending to limit the scope of the invention, **FIG. 1** illustrates this point with a ternary diagram, **114**, having three fundamental shape groups. The first group is a plate or pie shape, **102** and **104**; the second is a bar or cylinder shape, **106** and **108**, and the third is a cube or sphere shape, **110** and **112**. Typically, particles composing the solids used for making a solids-stabilized emulsion disclosed

herein will have some composite irregular shape that is somewhere between the two or three basic shape groups illustrated in ternary diagram, **114**. Accordingly, the size of particles composing such solids are preferably determined using a scanning probe microscopy (SPM) technique. One example of such a technique is atomic force microscopy. Digital Instruments of Santa Barbara, Calif. manufactures an atomic force microscope (AFM) known as the Nanoscope Multimode™, which has been used to characterize the average size and shape of some of the solid particles used in the working examples disclosed below.

**[0013]** Using AFM or some other SPM technique the maximum dimensions of a particle along its x, y, and z axes can be determined. Therefore, unless reference to an alternative particle size analysis method is otherwise indicated, reference to a particle size will mean the smallest of the three dimensions measured along a particle's x, y, and z axis, as measured by a SPM technique. In the case of a perfect sphere, **112**, or cube, **110**, each dimension is equal while in the case of a particle having the shape of a pie, **104**, or plate, **102**, the thickness of the particle, as measured along the z axis, is small relative to its length, x, and width y. The "average" particle size for a particular sample can be determined by obtaining a sufficient number of measurements, preferably 50 or more, of the smallest dimension for the array of particles being analyzed. The average size can be calculated using either the number of particles among the total measured having a particular x, y, or z value, whichever is smallest, or the weight contribution of the particles having a particular x, y, or z value, whichever is smallest, among the total weight for all particles measured.

**[0014]** If spherical in shape, the solid particles should preferably have an average size of about ten microns or less in diameter, more preferably about two microns or less, even more preferably about one micron or less and most preferably, 100 nanometers or less. If the solid particles are non-spherical in shape, they should preferably have an average surface area of about 200 square microns or less, more preferably about 20 square microns or less, even more preferably about ten square microns or less and most preferably, one square micron or less. The solid particles must also remain undissolved in both the oil and water phase of the emulsion under the conditions for which the emulsion is used.

**[0015]** The preferred solid particles are hydrophilic in nature, which include but are not limited to hydrophilic exfoliated clay, silica, carbonaceous solids and mixtures thereof. Hydrophilic silica, for example Aerosil-130™ sold by Degussa Corp. can also be used. Carbonaceous solids like refinery generated coke can also be used to prepare solids-stabilized oil-in-water emulsions. Refinery coke is generally a hydrophilic carbonaceous solid that can be ground to a powder of sufficient size for this invention. Montmorillonite clays, for example Bentonite and Kaolinite clays are also suitable for preparing the solids-stabilized oil-in-water emulsion. Bentonite clay is suitable because it can be easily exfoliated or divided by methods known in the art for exfoliation or division of clays. As mined, bentonite clays naturally consist of aggregates of particles that can be dispersed in water and broken up by shearing into units having average particle sizes of 2 microns or less. However, each of these particles is a laminated unit containing approximately 100 layers of fundamental silicate layers of 1

nm thickness bonded together by inclusions of atoms such as calcium in the layers. By exchanging the atoms such as calcium by sodium or lithium (which are larger and have strong attractions for water molecules in fresh water), and then exposing the bentonite to fresh water, the bentonite can be broken into individual 1 nm thick layers, called fundamental particles. The chemistry of this delamination process is well known to those skilled in the art of clay chemistry. The result of this delamination process is a gel consisting of divided bentonite clay.

**[0016]** Also, the source of the solids used for making a solids-stabilized oil-in-water emulsion may be indigenous to the formation where such emulsion is used, hereinafter known as formation solids or formation solid particles, or may be obtained external to the formation, whether taken from another formation, mined, or synthesized, hereinafter known as nonformation solids. In certain instances, in fact, both formation and nonformation solids may be compositionally similar, but simply derived from different sources.

**[0017]** The pH enhancing agent can be any agent that will raise the pH of the final emulsion, preferably to a range of about 7.5 to about 10. It is believed that if the final emulsion is not of a sufficient basicity, the solid particles which are initially hydrophilic (and provide stability to the water-external emulsion) gradually become hydrophobic because of slow absorption of polar hydrocarbons from the oil. A solids-stabilized oil-in-water emulsion formed without sufficient basicity will eventually invert to a water-in-oil (or oil-external) emulsion, which is undesirable for this invention. The preferred pH enhancing agent for this invention is a base, or mixture of bases. Preferred basic solutions include sodium hydroxide, potassium hydroxide, ammonium hydroxide, tertiary butyl ammonium hydroxide or mixtures thereof. A typical treat rate of a basic solution is between about 0.005 wt % to about 5.0 wt % based on the weight of the water.

**[0018]** The water used to form the emulsion preferably contain salts of Group I and Group II elements. Chlorides, sulfates, carbonates are some of the commonly occurring salts in water. Presence of these and other salts have a beneficial effect on emulsion formation and stability.

**[0019]** To make the solids-stabilized oil-in-water emulsion in accordance with this invention, oil can be added to water that contains the solid particles and the basic solution. This method is preferred where the solids-stabilized emulsion is prepared above ground, for example, in a surface facility. Alternatively, water containing the solid particles and the basic solution can be added to the oil, which is preferred for subterranean preparation of a solids-stabilized oil-in-water emulsion. The severity and duration of mixing required to form the solids-stabilized oil-in-water emulsion can be determined by one of ordinary skill in the art based upon such factors as the oil viscosity and oil composition. Mixing in a surface facility can be accomplished using static mixers (e.g., paddle mixers), blade mixers, inline mixers (e.g., plurality of fins in a pipe), or propagation of the oil-water mixture through an orifice. In a subsurface formation of emulsions, the mixing occurs in the subsurface pumps. The percentage of oil in water for the solids-stabilized oil-in-water emulsion can vary between 10% to 90%. The preferred treat rate of solid particles in the emulsion is between about 0.01 wt % to about 5.0 wt % based upon the weight of the oil.

[0020] It is preferred to have oil droplets in the size range of 1 micron to 200 microns in diameter suspended in the external water phase. In general, the dispersed oil droplets size distribution can be controlled by increasing the rate and/or duration of mixing and by increasing the concentration of solid particles and/or the pH enhancing agent. Conventional optical microscopy can be used to observe the oil droplets dispersed in water. Alternate methods to determine the oil droplet size distribution are known in the art, and can be used, such as the Coulter Counter method.

[0021] The following laboratory experiment and prophetic examples are intended to illustrate examples of making and using the solids-stabilized oil-in-water emulsions of this invention. However, to the extent that the following descriptions are specific to a particular embodiment or a particular use of the invention, this is intended to be illustrative only and is not to be construed as limiting the scope of the invention. On the contrary, it is intended to cover all alternatives, modifications, and equivalents that are included within the spirit and scope of the invention, as defined by the appended claims.

#### Laboratory Experiment—Reduction of Effective Viscosity of Oil

[0022] The viscosity of a sample of dry crude oil was measured to be 320 cp at 140° F. using a Brookfield viscometer. An oil-external emulsion containing 30 volume % (vol. %) water was made with this oil sample, which increased the effective viscosity of the oil (i.e. the viscosity of the water-in-oil emulsion) to 940 cp (140° F. at 380 sec<sup>-1</sup> shear rate). A water-external emulsion was made with this crude oil sample, also containing 30 vol. % water, by mixing bentonite solid particles (at a treat rate of between 0.01 wt % to about 5 wt % based on the weight of the oil), and 100 ppm of ammonium hydroxide (to bring the pH of the final emulsion to a range of about 7.5 to 10) to the water and oil, and shearing until the water-external emulsion was formed. The resulting water-external emulsion exhibited a viscosity of 91 cp (140° F. at 380 sec<sup>-1</sup> shear rate), which is a viscosity reduction of 229 cp from the 320 cp viscosity of the dry oil.

#### Production of Oils Using a Solids-Stabilized Oil-In-Water Emulsion.

[0023] An aqueous solution comprising a volume of water containing a pH enhancing agent (for instance a basic solution like ammonium hydroxide), and hydrophilic solid particles (such as bentonite that has been exfoliated into individual, fundamental layers), is pumped into a subterranean oil formation from the surface. The aqueous solution is provided within the subterranean formation at a location so that it contacts the produced oil and connate water (if any) at a depth below where the fluids enter the submersible pump. The aqueous solution, connate water and oil are mixed within the subterranean formation by propagation of the mixture through pores in the formation and/or mixing in the submersible pump thereby forming the solids-stabilized oil-in-water emulsion. The solids-stabilized oil-in-water emulsion has a lower viscosity than the original dry oil and a lower viscosity than the water-in-oil emulsions that can be formed in the formation by mixing of the dry oil and connate water. The low viscosity solids-stabilized oil-in-water emulsion can be produced from the subterranean formation using production methods commonly known in the industry.

[0024] The amount of solid particles and basic solution added to the injected water to form the aqueous solution can

be determined by one skilled in the art pursuant to the particular characteristics of the subterranean reservoir and oil being produced. The produced oil-in-water emulsion preferably has a final concentration of solid particles in the range of about 0.01 wt % to about 5 wt % based on the weight of the oil. The amount of basic solution added to the injected water should be sufficient to raise the pH of the resulting oil-in-water emulsion to above 7.0, and preferably to a range of 7.5-10. The amount of base needed depends on the acid content (Total Acid Number, TAN) of the oil. For example, for oils whose TAN ranges from 4-7, the amount of ammonia that needs to be added is about 100-200 ppm in the final emulsion. Generally, it is preferred to add an amount of base sufficient to neutralize at least 25% of the acids. The oil-in-water emulsion produced by addition of solid particles and the basic solution will usually remain stable for longer periods of time and have a lower viscosity than an emulsion made by addition of a basic solution alone. Moreover, the resulting water-external emulsion has a substantially lower viscosity than the dry oil alone, and can be lifted at lower cost and at higher rate than either the dry oil alone or the oil-external emulsions usually formed in the wellbore.

[0025] Once produced, the solids-stabilized water-external emulsion can be allowed to gravity settle in surface facilities to concentrate the oil content to approximately 70-80 vol. % oil. The excess water can be removed after separation. This water-external emulsion containing 70-80 vol. % oil is well suited for transport in pipelines as described below. To break the water-external emulsion, a sufficient pH reducing agent (such as an acidic solution) can be added to reduce the pH of the emulsion to a value below about 7.0. Water can then be removed by conventional dehydration methods such as using electrostatic coalescence devices or hydrocyclones.

#### Transportation of Oil Using a Solids-Stabilized Oil-In-Water Emulsion.

[0026] Water-external emulsions can be transported in pipelines to achieve higher net flowrates of oil than in the transport of dry oil alone. The percentage of oil in water for this embodiment can vary between 10% to 90%, and is preferably in the range of 70 to 80%. In a particular example, oil is combined with an aqueous solution comprising water, a pH enhancing agent (such as a basic solution), and solid particles and mixed until the solids-stabilized oil-in-water emulsion is formed. The amount of basic solution is preferably in a range between about 0.005 wt % to about 5 wt % based upon the weight of the water. The pH of the resulting oil-in-water emulsion should be above 7.0 and preferably be in the 7.5-10 range. The solid particles can be added at a treat range of about 0.01 wt % to about 5 wt % based upon the weight of the oil.

[0027] The oil useful for this embodiment of invention can be any oil including but not limited to crude oil, crude oil distillates, crude oil residue, synthetic oil, and mixtures thereof.

[0028] In propagating the emulsion through a pipe it is preferred to first contact the inner walls of the pipe with a wettability altering agent to make the inner walls of the pipe water-wet to aid the propagation of the oil-in-water emulsion. The wettability altering agent can be water or another known drag reducer that can be selected by one of ordinary

skill in the art. After contacting the inner walls of the pipe with the wettability altering agent, the oil-in-water emulsion can be pumped through the pipe.

[0029] High-oil content, solids-stabilized oil-in-water emulsions are therefore good candidates for transportation in pipelines using flow regimes of either self-lubricating core annular flow or as uniform, lower-viscosity water-external emulsions. In core annular flow, forming a low-viscosity annulus near the pipe wall further reduces pressure drop. Because the viscosity of a solids-stabilized oil-in-water emulsions is not greatly affected by temperature (because the viscosity of water, the continuous phase, is not greatly affected by temperature), such oil-in-water emulsions do not have to be heated to high temperature to maintain an acceptably low viscosity for economical transport. Another benefit of the oil-in-water emulsion formed in the above manner is that the oil phase does not tend to wet steel. Thus, these emulsions will have fewer tendencies to wet or "foul" the pipeline walls than oil-external emulsions or dry oil.

[0030] The present invention has been described in connection with its preferred embodiments. However, to the extent that the foregoing description was specific to a particular embodiment or a particular use of the invention, this was intended to be illustrative only and is not to be construed as limiting the scope of the invention. On the contrary, it was intended to cover all alternatives, modifications, and equivalents that are included within the spirit and scope of the invention, as defined by the appended claims.

We claim:

1. A method for preparing a solids-stabilized oil-in-water emulsion comprising:

combining water, oil, micron to sub-micron sized hydrophilic solid particles and a pH enhancing agent; and

mixing until said solid-stabilized oil-in-water emulsion is formed.

2. The method of claim 1, wherein said step of combining comprises forming an aqueous solution comprising said water, said solid particles and said pH enhancing agent and injecting said aqueous solution into a subterranean formation to combine with said oil.

3. The method of claim 2, wherein said step of mixing occurs in said subterranean formation.

4. The method of claim 1, wherein said oil, said water, said hydrophilic solid particles and said pH enhancing agent are combined in a surface facility.

5. The method of claim 1, wherein said hydrophilic solid particles are combined at a treat rate of about 0.01 wt % to about 5 wt % based upon the weight of said oil.

6. The method of claim 1, wherein said hydrophilic solid particles comprise spherically shaped solid particles with an average particle size of less than about 10 microns in diameter.

7. The method of claim 1, wherein said hydrophilic solid particles comprise non-spherically shaped solid particles with an average surface area of less than about 200 square microns.

8. The method of claim 1, wherein said pH enhancing agent is combined at a treat rate to provide said oil-in-water emulsion with a pH in a range of about 7.5 to about 10.

9. The method of claim 8, wherein said pH enhancing agent comprises a basic solution.

10. The method of claim 9, wherein said basic solution is selected from the group consisting of sodium hydroxide, potassium hydroxide, ammonium hydroxide, tertiary butyl ammonium hydroxide and mixtures thereof.

11. The method of claim 9, wherein said basic solution is provided at a treat rate of about 0.005 wt % to about 5 wt % based on the weight of said water.

12. The method of claim 1, wherein said oil is combined with said water, said solid particles and said pH enhancing agent to form an oil-in-water emulsion comprising about 10% to about 80% oil.

13. The method of claim 1, wherein said step of mixing continues until said oil comprises oil droplets dispersed in said water in size range of about 1 micron to about 200 microns in diameter.

14. A solids-stabilized oil-in-water emulsion comprising:

oil droplets dispersed in water,

micron to sub-micron sized hydrophilic solid particles suspended at the interface between said oil droplets and said water, and

a pH enhancing agent.

15. The emulsion of claim 14, wherein said oil-in-water emulsion comprises about 10 wt % to about 80 wt % oil based on the weight of the emulsion.

16. The emulsion of claim 14, wherein said hydrophilic solid particles are at a concentration of about 0.01 wt % to 5 wt % based on the weight of said oil.

17. The emulsion of claim 14, wherein said hydrophilic solid particles comprise spherically shaped solid particles with an average particle size of less than about 10 microns in diameter.

18. The emulsion of claim 14, wherein said hydrophilic solid particles comprise non-spherically shaped solid particles with an average surface area of less than about 200 square microns.

19. The emulsion of claim 14, wherein said pH enhancing agent comprises a basic solution.

20. The emulsion of claim 19, wherein said basic solution is selected from the group consisting of sodium hydroxide, potassium hydroxide, ammonium hydroxide, tertiary butyl ammonium hydroxide and mixtures thereof.

21. The emulsion of claim 19, wherein said basic solution is present at a concentration of about 0.005 wt % to about 5 wt % based on the weight of the water.

22. The emulsion of claim 14, wherein said oil droplets are in the size range of about 1 micron to about 200 microns in diameter.

23. The method of claim 1, wherein said step of combining, said step of mixing, or both occur in the subsurface.

24. The method of claim 1, wherein said step of combining, said step of mixing, or both occur in the subsurface.

25. The method of claim 1, wherein said step of mixing comprises mixing by a submersible pump in the subsurface.

26. A solid-stabilized oil-in-water emulsion formed by the method of claim 1.

27. A solid-stabilized oil-in-water emulsion formed by the method of claim 2.

28. A solid-stabilized oil-in-water emulsion formed by the method of claim 3.

29. A solid-stabilized oil-in-water emulsion formed by the method of claim 4.

30. A solid-stabilized oil-in-water emulsion formed by the method of claim 5.

**31.** A solid-stabilized oil-in-water emulsion formed by the method of claim 6.

**32.** A solid-stabilized oil-in-water emulsion formed by the method of claim 7.

**33.** A solid-stabilized oil-in-water emulsion formed by the method of claim 8.

**34.** A solid-stabilized oil-in-water emulsion formed by the method of claim 9.

**35.** A solid-stabilized oil-in-water emulsion formed by the method of claim 10.

**36.** A solid-stabilized oil-in-water emulsion formed by the method of claim 11.

**37.** A solid-stabilized oil-in-water emulsion formed by the method of claim 12.

**38.** A solid-stabilized oil-in-water emulsion formed by the method of claim 13.

**39.** A solid-stabilized oil-in-water emulsion formed by the method of claim 24.

**40.** A solid-stabilized oil-in-water emulsion formed by the method of claim 25.

**41.** A method for preparing a solids-stabilized oil-in-water emulsion comprising:

combining water, oil, micron to sub-micron sized hydrophilic formation solid particles and a pH enhancing agent; and

mixing until said solid-stabilized oil-in-water emulsion is formed.

**42.** A solid-stabilized oil-in-water emulsion formed by the method of claim 41.

\* \* \* \* \*