



(12) **United States Design Patent** (10) **Patent No.:** **US D926,982 S**  
**Blain et al.** (45) **Date of Patent:** **\*\* Aug. 3, 2021**

(54) **INTERBODY BONE IMPLANT**

(56) **References Cited**

- (71) Applicant: **Spinal Elements, Inc.**, Carlsbad, CA (US)
- (72) Inventors: **Jason Blain**, Encinitas, CA (US); **Greg Martin**, Encinitas, CA (US)
- (73) Assignee: **Spinal Elements, Inc.**, Carlsbad, CA (US)
- (\*\*) Term: **15 Years**
- (21) Appl. No.: **29/732,354**
- (22) Filed: **Apr. 23, 2020**

U.S. PATENT DOCUMENTS

86,016	A	1/1869	Howell
1,630,239	A	5/1927	Binkley et al.
1,822,280	A	9/1931	Ervay
1,822,330	A	9/1931	Anslie
2,486,303	A	10/1949	Longfellow
2,706,023	A	4/1955	Merritt
2,967,282	A	1/1961	Schwartz et al.
3,111,945	A	11/1963	Von Solbrig
3,149,808	A	9/1964	Weckesser
3,570,497	A	3/1971	Lemole
3,867,728	A	2/1975	Stubstad et al.
3,875,595	A	4/1975	Froning
3,879,767	A	4/1975	Stubstad
4,001,896	A	1/1977	Arkangel
4,037,603	A	7/1977	Wendorff
4,085,466	A	4/1978	Goodfellow et al.
4,119,091	A	10/1978	Partridge
4,156,296	A	5/1979	Johnson et al.
4,164,793	A	8/1979	Swanson
4,166,292	A	9/1979	Bokros
4,231,121	A	11/1980	Lewis
D261,935	S	11/1981	Halloran
4,312,337	A	1/1982	Donohue
4,323,217	A	4/1982	Dochterman
4,349,921	A	9/1982	Kuntz
4,502,161	A	3/1985	Wall
D279,502	S	7/1985	Halloran
D279,503	S	7/1985	Halloran
4,535,764	A	8/1985	Ebert
4,573,458	A	3/1986	Lower
4,573,459	A	3/1986	Litton
4,634,445	A	1/1987	Helal
4,662,371	A	5/1987	Whipple et al.
4,706,659	A	11/1987	Matthews et al.
4,714,469	A	12/1987	Kenna
4,722,331	A	2/1988	Fox
4,730,615	A	3/1988	Sutherland et al.
4,759,766	A	7/1988	Buettner-Janz et al.
4,759,769	A	7/1988	Hedman et al.
4,772,287	A	9/1988	Ray et al.
4,773,402	A	9/1988	Asher et al.
4,834,757	A	5/1989	Brantigan
4,863,477	A	9/1989	Monson
4,880,429	A	11/1989	Stone
4,904,260	A	2/1990	Ray et al.
4,907,577	A	3/1990	Wu
4,911,718	A	3/1990	Lee et al.
4,919,667	A	4/1990	Richmond
4,923,471	A	5/1990	Morgan

**Related U.S. Application Data**

- (60) Continuation of application No. 29/696,411, filed on Jun. 27, 2019, now Pat. No. Des. 884,896, which is a continuation of application No. 29/665,662, filed on Oct. 5, 2018, now Pat. No. Des. 857,900, which is a continuation of application No. 29/632,794, filed on Jan. 10, 2018, now Pat. No. Des. 834,194, which is a continuation of application No. 29/602,768, filed on May 3, 2017, now Pat. No. Des. 810,942, which is a continuation of application No. 29/562,284, filed on Apr. 25, 2016, now Pat. No. Des. 790,062, which is a continuation of application No. 29/537,496, filed on Aug. 26, 2015, now Pat. No. Des. 765,854, which is a division of application No. 29/404,921, filed on Oct. 26, 2011, now Pat. No. Des. 739,935.
- (51) **LOC (13) Cl.** ..... **24-03**
- (52) **U.S. Cl.**  
USPC ..... **D24/155**
- (58) **Field of Classification Search**  
USPC ..... D24/155, 133, 135; D12/204, 207  
CPC ..... A61F 2/4611; A61F 2/442; A61F 2/447;  
A61F 2220/0025; A61F 2310/00023;  
A61F 2310/00017; A61F 2002/4475;  
A61F 2002/30841; A61F 2002/2835;  
A61F 2002/30904; A61F 2002/30785;  
A61F 2002/443; A61F 2002/30578  
See application file for complete search history.

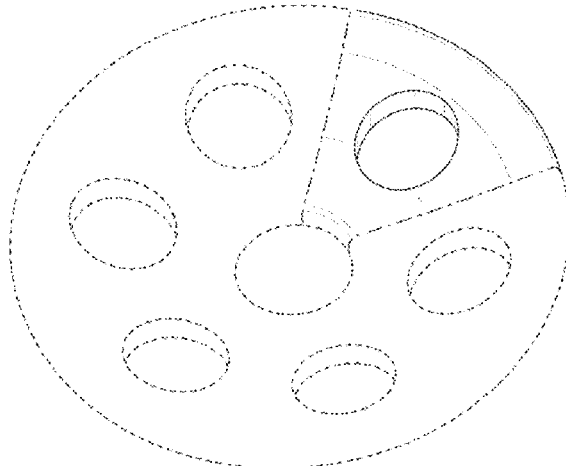

# US D926,982 S

4,936,848	A	6/1990	Bagby	5,702,450	A	12/1997	Bisserie	
4,941,466	A	7/1990	Romano	5,707,373	A	1/1998	Sevrain et al.	
4,959,065	A	9/1990	Arnett et al.	5,713,542	A	2/1998	Benoit	
4,969,909	A	11/1990	Barouk	5,716,415	A	2/1998	Steffee	
5,000,165	A	3/1991	Watanabe	5,725,582	A	3/1998	Bevan et al.	
5,002,546	A	3/1991	Romano	5,741,260	A	4/1998	Songer et al.	
5,011,484	A	4/1991	Bréard	5,741,261	A	4/1998	Moskovitz et al.	
5,015,255	A	5/1991	Kuslich	D395,138	S	6/1998	Ohata	
5,047,055	A	9/1991	Bao et al.	5,766,251	A	6/1998	Koshino	
5,062,845	A	11/1991	Kuslich	5,766,253	A	6/1998	Brosnahan	
5,071,437	A	12/1991	Steffee	5,772,663	A	6/1998	Whiteside et al.	
5,092,866	A	3/1992	Breard et al.	5,797,916	A	8/1998	McDowell	
5,112,013	A	5/1992	Tolbert et al.	5,824,093	A	10/1998	Ray et al.	
5,112,346	A	5/1992	Hiltebrandt et al.	5,824,094	A	10/1998	Serhan et al.	
5,127,912	A	7/1992	Ray et al.	5,836,948	A	11/1998	Zucherman et al.	
5,135,188	A	8/1992	Anderson et al.	5,851,208	A	12/1998	Trott	
5,147,404	A	9/1992	Downey	5,860,977	A	1/1999	Zucherman et al.	
5,171,280	A	12/1992	Baumgartner	5,865,846	A	2/1999	Bryan et al.	
5,192,326	A	3/1993	Bao et al.	5,868,745	A	2/1999	Alleyne	
5,192,327	A	3/1993	Brantigan	5,876,404	A	3/1999	Zucherman et al.	
5,209,755	A	5/1993	Abrahan et al.	5,879,396	A	3/1999	Walston et al.	
5,258,031	A	11/1993	Salib et al.	5,888,203	A	3/1999	Goldberg	
5,282,861	A	2/1994	Kaplan	5,893,889	A	4/1999	Harrington	
5,286,249	A	2/1994	Thibodaux	5,895,428	A	4/1999	Berry	
5,300,073	A	4/1994	Ray et al.	RE36,221	E	6/1999	Breard et al.	
5,306,275	A	4/1994	Bryan	5,918,604	A	7/1999	Whelan	
5,306,308	A	4/1994	Gross et al.	5,951,555	A	9/1999	Rehak et al.	
5,306,309	A	4/1994	Wagner et al.	5,964,765	A	10/1999	Fenton et al.	
5,326,364	A	7/1994	Clift, Jr. et al.	5,993,452	A	11/1999	Vandewalle	
5,330,479	A	7/1994	Whitmore	5,997,542	A	12/1999	Burke	
5,360,431	A	11/1994	Puno et al.	6,001,130	A	12/1999	Bryan et al.	
5,368,596	A	11/1994	Burkhart	6,014,588	A	1/2000	Fitz	
5,370,697	A	12/1994	Baumgartner	6,019,763	A *	2/2000	Nakamura .....	A61B 17/866
5,372,598	A	12/1994	Luhr et al.					523/105
5,400,784	A	3/1995	Durand et al.	6,019,792	A	2/2000	Cauthen	
5,401,269	A	3/1995	Buttner-Janz et al.	6,039,763	A	3/2000	Shelokov	
5,413,576	A	5/1995	Rivard	6,048,342	A	4/2000	Zucherman et al.	
5,415,661	A	5/1995	Holmes	6,050,998	A	4/2000	Fletcher	
5,425,773	A	6/1995	Boyd et al.	6,063,121	A	5/2000	Xavier et al.	
5,437,672	A	8/1995	Alleyne	6,066,325	A	5/2000	Wallace et al.	
5,445,639	A	8/1995	Kuslich et al.	6,068,630	A	5/2000	Zucherman et al.	
5,458,642	A	10/1995	Beer et al.	RE36,758	E	6/2000	Fitz	
5,458,643	A	10/1995	Oka et al.	6,080,157	A	6/2000	Cathro et al.	
5,462,542	A	10/1995	Alesi, Jr.	6,099,531	A	8/2000	Bonutti	
5,487,756	A	1/1996	Kallesoe et al.	6,102,347	A	8/2000	Benoit	
5,491,882	A	2/1996	Walston et al.	6,106,558	A	8/2000	Picha	
5,496,142	A	3/1996	Fodor et al.	6,113,637	A	9/2000	Gill et al.	
5,496,318	A	3/1996	Howland et al.	6,132,464	A	10/2000	Martin	
5,507,823	A	4/1996	Walston et al.	6,132,465	A	10/2000	Ray et al.	
5,509,918	A	4/1996	Romano	6,146,422	A	11/2000	Lawson	
5,514,180	A	5/1996	Heggeness et al.	6,156,067	A	12/2000	Bryan et al.	
5,527,312	A	6/1996	Ray	6,179,839	B1 *	1/2001	Weiss .....	A61B 17/1659
5,527,314	A	6/1996	Brumfield et al.					606/280
5,534,028	A	7/1996	Bao et al.	D439,340	S *	3/2001	Michelson .....	D24/155
5,534,030	A	7/1996	Navarro et al.	6,200,322	B1	3/2001	Branch et al.	
5,540,706	A	7/1996	Aust et al.	6,293,949	B1	9/2001	Justis et al.	
5,545,229	A	8/1996	Parsons et al.	D450,122	S *	11/2001	Michelson .....	D24/155
5,549,619	A	8/1996	Peters et al.	6,325,803	B1	12/2001	Schumacher et al.	
5,556,431	A	9/1996	Buttner-Janz	D454,953	S	3/2002	Michelson	
5,562,738	A	10/1996	Boyd et al.	6,368,325	B1	4/2002	McKinley et al.	
5,571,105	A	11/1996	Gundolf	6,368,350	B1	4/2002	Erickson et al.	
5,571,131	A	11/1996	Ek et al.	6,371,958	B1	4/2002	Overaker	
5,571,189	A	11/1996	Kuslich	6,375,573	B2	4/2002	Romano	
5,571,191	A	11/1996	Fitz	6,379,386	B1	4/2002	Resch et al.	
5,577,995	A	11/1996	Walker et al.	6,409,765	B1	6/2002	Bianchi et al.	
5,586,989	A	12/1996	Bray, Jr.	D460,188	S	7/2002	Michelson	
5,591,165	A	1/1997	Jackson	D460,189	S	7/2002	Michelson	
5,603,713	A	2/1997	Aust et al.	6,419,678	B1	7/2002	Asfora	
5,638,700	A	6/1997	Shechter	6,419,703	B1	7/2002	Fallin et al.	
5,645,597	A	7/1997	Krapiva	6,436,099	B1	8/2002	Drewry et al.	
5,645,599	A	7/1997	Samani	6,436,101	B1	8/2002	Hamada et al.	
5,649,947	A	7/1997	Auerbach et al.	6,436,146	B1	8/2002	Hassler et al.	
5,653,762	A	8/1997	Pisharodi	D463,560	S *	9/2002	Michelson .....	D24/155
5,674,295	A	10/1997	Ray et al.	6,447,544	B1	9/2002	Michelson	
5,674,296	A	10/1997	Bryan et al.	6,470,207	B1	10/2002	Simon et al.	
5,676,701	A	10/1997	Yuan et al.	6,565,605	B2	5/2003	Goble et al.	
5,683,464	A	11/1997	Wagner et al.	6,572,617	B1	6/2003	Senegas	
5,683,466	A	11/1997	Vitale	6,579,318	B2	6/2003	Varga et al.	
5,700,265	A	12/1997	Romano	6,579,319	B2	6/2003	Goble et al.	

# US D926,982 S

6,589,244	B1	7/2003	Sevrain et al.	8,961,613	B2	2/2015	Assell et al.
6,600,956	B2	7/2003	Maschino et al.	D724,733	S	3/2015	Blain et al.
6,607,530	B1	8/2003	Carl et al.	8,974,456	B2	3/2015	Allen et al.
6,610,091	B1	8/2003	Reiley	8,979,529	B2	3/2015	Marcus
D479,331	S	9/2003	Pike et al.	8,992,533	B2	3/2015	Blain et al.
6,626,944	B1	9/2003	Taylor	8,998,953	B2	4/2015	Blain
6,641,614	B1	11/2003	Wagner et al.	9,017,389	B2	4/2015	Assell et al.
6,656,178	B1	12/2003	Veldhuizen et al.	9,060,787	B2	6/2015	Blain et al.
6,656,195	B2	12/2003	Peters et al.	9,101,410	B1	8/2015	Urrea
6,669,697	B1	12/2003	Pisharodi	D739,935	S	9/2015	Blain et al.
6,669,729	B2	12/2003	Chin	9,149,283	B2	10/2015	Assell et al.
6,679,914	B1	1/2004	Gabbay	9,161,763	B2	10/2015	Assell et al.
6,706,068	B2	3/2004	Ferree	9,179,943	B2	11/2015	Blain
6,743,232	B2*	6/2004	Overaker .....	9,220,547	B2	12/2015	Blain et al.
			A61F 2/30756	D748,262	S	1/2016	Blain
			606/327	9,233,006	B2	1/2016	Assell et al.
6,761,720	B1	7/2004	Senegas	D748,793	S	2/2016	Blain
6,764,491	B2	7/2004	Frey et al.	9,265,546	B2	2/2016	Blain
6,770,095	B2	8/2004	Grinberg et al.	9,271,765	B2	3/2016	Blain
6,783,527	B2	8/2004	Drewry et al.	9,301,786	B2	4/2016	Blain
6,790,210	B1	9/2004	Cragg et al.	9,314,277	B2	4/2016	Assell et al.
6,802,863	B2	10/2004	Lawson et al.	9,345,488	B2	5/2016	Assell et al.
6,811,567	B2	11/2004	Reiley	9,421,044	B2	8/2016	Blain et al.
6,902,566	B2	6/2005	Zucherman et al.	D765,853	S	9/2016	Blain et al.
6,908,484	B2	6/2005	Zubok et al.	D765,854	S	9/2016	Blain et al.
6,966,930	B2	11/2005	Arnin et al.	9,456,855	B2	10/2016	Blain et al.
6,974,478	B2	12/2005	Reiley et al.	9,517,077	B2	12/2016	Blain et al.
6,974,479	B2	12/2005	Trieu	D777,921	S	1/2017	Blain et al.
7,004,971	B2	2/2006	Serhan et al.	D780,315	S	2/2017	Blain et al.
D517,404	S*	3/2006	Schluter .....	9,572,602	B2	2/2017	Blain et al.
7,008,429	B2	3/2006	Golobek	D810,942	S	2/2018	Blain et al.
7,013,675	B2	3/2006	Marquez-Pickering	D812,754	S	3/2018	Blain et al.
7,051,451	B2	5/2006	Augustino et al.	9,615,861	B2	4/2017	Perez-Cruet et al.
7,074,238	B2	7/2006	Stinson et al.	D790,062	S	6/2017	Blain et al.
7,101,375	B2	9/2006	Zucherman et al.	9,675,387	B2	6/2017	Blain
7,223,269	B2	5/2007	Chappuis	9,743,937	B2	8/2017	Blain et al.
D565,180	S*	3/2008	Liao .....	9,808,294	B2	11/2017	Blain
7,371,238	B2	5/2008	Sololeski et al.	9,820,784	B2	11/2017	Blain et al.
7,458,981	B2	12/2008	Fielding et al.	9,839,450	B2	12/2017	Blain et al.
7,517,358	B2	4/2009	Petersen	D810,942	S	2/2018	Blain et al.
7,537,611	B2	5/2009	Lee	D812,754	S	3/2018	Blain et al.
7,559,940	B2	7/2009	McGuire et al.	9,936,984	B2	4/2018	Blain
7,563,286	B2	7/2009	Gerber et al.	10,022,161	B2	7/2018	Blain
7,585,300	B2	9/2009	Cha	10,085,776	B2	10/2018	Blain
7,608,104	B2	10/2009	Yuan et al.	D834,194	S	11/2018	Blain et al.
7,695,472	B2	4/2010	Young	10,194,955	B2	2/2019	Blain et al.
7,799,077	B2	9/2010	Lang et al.	10,251,679	B2	4/2019	Blain et al.
7,806,895	B2	10/2010	Weier et al.	D857,900	S	8/2019	Blain et al.
7,846,183	B2	12/2010	Blain	10,368,921	B2	8/2019	Blain
7,862,590	B2	1/2011	Lim et al.	10,426,524	B2	10/2019	Blain
7,935,136	B2	5/2011	Alamin et al.	10,624,680	B2	4/2020	Blain
D643,121	S	8/2011	Milford et al.	D884,896	S	5/2020	Blain et al.
7,993,370	B2	8/2011	Jahng	2001/0018614	A1	8/2001	Bianchi
7,998,172	B2	8/2011	Blain	2002/0018799	A1	2/2002	Spector et al.
8,052,728	B2	11/2011	Hestad	2002/0019637	A1	2/2002	Frey et al.
8,109,971	B2	2/2012	Hale	2002/0029039	A1	3/2002	Zucherman et al.
8,133,225	B2	3/2012	Pieske	2002/0040227	A1	4/2002	Harari
8,163,016	B2	4/2012	Linares	2002/0065557	A1	5/2002	Goble et al.
8,172,877	B2	5/2012	Winslow et al.	2002/0072800	A1	6/2002	Goble et al.
8,177,810	B2	5/2012	Ferree	2002/0077700	A1	6/2002	Varga et al.
8,192,468	B2	6/2012	Biedermann et al.	2002/0086047	A1	7/2002	Mueller et al.
8,216,275	B2	7/2012	Fielding et al.	2002/0120335	A1	8/2002	Angelucci et al.
8,231,661	B2	7/2012	Carls	2002/0123806	A1	9/2002	Reiley
8,246,655	B2	8/2012	Jackson et al.	2002/0138077	A1	9/2002	Ferree
8,267,966	B2	9/2012	McCormack et al.	2002/0151895	A1	10/2002	Soboleski et al.
8,292,954	B2	10/2012	Robinson et al.	2002/0173800	A1	11/2002	Dreyfuss et al.
8,306,307	B2	11/2012	Koike et al.	2002/0173813	A1	11/2002	Peterson et al.
8,382,801	B2	2/2013	Lamborne et al.	2002/0198527	A1	12/2002	Muckter
8,394,125	B2	3/2013	Assell	2003/0004572	A1	1/2003	Goble et al.
8,460,346	B2	6/2013	Ralph et al.	2003/0028250	A1	2/2003	Reiley et al.
8,486,078	B2	7/2013	Carl et al.	2003/0040797	A1	2/2003	Fallin et al.
8,496,691	B2	7/2013	Blain	2003/0093152	A1	5/2003	Pedersen et al.
8,579,903	B2	11/2013	Carl	2003/0093154	A1	5/2003	Estes et al.
8,652,137	B2	2/2014	Blain et al.	2003/0120343	A1	6/2003	Whelan
8,740,942	B2	6/2014	Blain	2003/0176919	A1	9/2003	Schmieding
8,740,949	B2	6/2014	Blain	2003/0176922	A1	9/2003	Lawson et al.
8,753,345	B2	6/2014	McCormack et al.	2003/0187454	A1	10/2003	Gill et al.
8,784,423	B2	7/2014	Kowarsch et al.	2003/0191532	A1	10/2003	Goble et al.
8,858,597	B2	10/2014	Blain	2003/0204259	A1	10/2003	Goble et al.
8,882,804	B2	11/2014	Blain	2003/0216669	A1	11/2003	Lang et al.
				2003/0233146	A1	12/2003	Grinberg et al.

## US D926,982 S

Page 4

2004/0006391	A1	1/2004	Reiley	2008/0183211	A1	7/2008	Lamborne et al.
2004/0010318	A1	1/2004	Ferree	2008/0228225	A1	9/2008	Trautwein et al.
2004/0024462	A1	2/2004	Ferree et al.	2008/0255664	A1	10/2008	Hogendijk et al.
2004/0049271	A1	3/2004	Biedermann et al.	2008/0262549	A1	10/2008	Bennett et al.
2004/0049272	A1	3/2004	Reiley	2008/0287996	A1	11/2008	Soholeski et al.
2004/0049273	A1	3/2004	Reiley	2009/0005818	A1	1/2009	Chin et al.
2004/0049274	A1	3/2004	Reiley	2009/0005873	A1	1/2009	Slivka et al.
2004/0049275	A1	3/2004	Reiley	2009/0018662	A1	1/2009	Pasquet et al.
2004/0049276	A1	3/2004	Reiley	2009/0024166	A1	1/2009	Carl et al.
2004/0049277	A1	3/2004	Reiley	2009/0072006	A1	3/2009	Clauson et al.
2004/0049278	A1	3/2004	Reiley	2009/0076617	A1	3/2009	Ralph et al.
2004/0049281	A1	3/2004	Reiley	2009/0105766	A1	4/2009	Thompson et al.
2004/0059429	A1	3/2004	Amin et al.	2009/0125066	A1	5/2009	Kraus et al.
2004/0087954	A1	5/2004	Allen et al.	2009/0138048	A1	5/2009	Baccelli et al.
2004/0116927	A1	6/2004	Graf	2009/0171360	A1	7/2009	Whelan
2004/0127989	A1	7/2004	Dooris et al.	2009/0198282	A1	8/2009	Fielding et al.
2004/0143264	A1	7/2004	McAfee	2009/0248077	A1	10/2009	Johns
2004/0176844	A1	9/2004	Zubok et al.	2009/0264928	A1	10/2009	Blain
2004/0195727	A1	10/2004	Stoy	2009/0264929	A1	10/2009	Alamin et al.
2004/0199166	A1	10/2004	Schmieding et al.	2009/0270918	A1	10/2009	Attia et al.
2004/0215341	A1	10/2004	Sybert et al.	2009/0270929	A1	10/2009	Suddaby
2004/0230201	A1	11/2004	Yuan et al.	2009/0306716	A1	12/2009	Beger et al.
2004/0230304	A1	11/2004	Yuan et al.	2009/0326589	A1	12/2009	Lemoine et al.
2005/0010291	A1	1/2005	Stinson et al.	2010/0010548	A1	1/2010	Hermida Ochoa
2005/0015146	A1	1/2005	Louis et al.	2010/0063550	A1	3/2010	Felix et al.
2005/0043797	A1	2/2005	Lee	2010/0076503	A1	3/2010	Beyar et al.
2005/0043799	A1	2/2005	Reiley	2010/0131008	A1	5/2010	Overes et al.
2005/0049705	A1	3/2005	Hale et al.	2010/0168864	A1	7/2010	White et al.
2005/0055096	A1	3/2005	Serhan et al.	2010/0179553	A1	7/2010	Ralph et al.
2005/0059972	A1	3/2005	Biscup	2010/0185241	A1	7/2010	Malandain et al.
2005/0107879	A1	5/2005	Christensen et al.	2010/0191286	A1	7/2010	Butler
2005/0131409	A1	6/2005	Chervitz et al.	2010/0204700	A1	8/2010	Falahee
2005/0131538	A1	6/2005	Chervitz et al.	2010/0204732	A1	8/2010	Aschmann et al.
2005/0143818	A1	6/2005	Yuan et al.	2010/0234894	A1	9/2010	Alamin et al.
2005/0154463	A1	7/2005	Trieu	2010/0274289	A1	10/2010	Carls et al.
2005/0159746	A1	7/2005	Grab et al.	2010/0292698	A1	11/2010	Hulliger et al.
2005/0197700	A1	9/2005	Boehem et al.	2010/0298829	A1	11/2010	Schaller et al.
2005/0204515	A1	9/2005	Hewes	2010/0318133	A1	12/2010	Tornier
2005/0216017	A1	9/2005	Fielding et al.	2011/0015744	A1	1/2011	Squires et al.
2005/0240201	A1	10/2005	Yeung	2011/0022050	A1	1/2011	McClellan et al.
2005/0251256	A1	11/2005	Reiley	2011/0022089	A1	1/2011	Assell et al.
2005/0256494	A1	11/2005	Datta	2011/0034956	A1	2/2011	Mazda et al.
2006/0004367	A1	1/2006	Alamin et al.	2011/0060366	A1	3/2011	Heim et al.
2006/0036323	A1	2/2006	Carl et al.	2011/0098816	A1	4/2011	Jacob et al.
2006/0041311	A1	2/2006	McLeer	2011/0160772	A1	6/2011	Arcenio et al.
2006/0084985	A1	4/2006	Kim	2011/0172712	A1	7/2011	Chee et al.
2006/0085006	A1	4/2006	Ek et al.	2011/0245875	A1	10/2011	Karim
2006/0085072	A1	4/2006	Funk et al.	2011/0295318	A1	12/2011	Alamin et al.
2006/0111782	A1	5/2006	Petersen	2011/0301644	A1	12/2011	Belliard
2006/0116684	A1	6/2006	Whelan	2012/0022591	A1	1/2012	Baccelli et al.
2006/0149289	A1	7/2006	Winslow et al.	2012/0022649	A1	1/2012	Robinson et al.
2006/0149375	A1	7/2006	Yuan et al.	2012/0035658	A1	2/2012	Goble et al.
2006/0200137	A1	9/2006	Soboleski et al.	2012/0041441	A1	2/2012	Bernstein et al.
2006/0241597	A1	10/2006	Mitchell et al.	2012/0046749	A1	2/2012	Tatsumi
2006/0241601	A1	10/2006	Trautwein et al.	2012/0101502	A1	4/2012	Kartalian et al.
2006/0241758	A1	10/2006	Peterman et al.	2012/0150231	A1	6/2012	Alamin et al.
2006/0241778	A1	10/2006	Ogilvie	2012/0221060	A1	8/2012	Blain
2006/0247650	A1	11/2006	Yerby et al.	2012/0245586	A1	9/2012	Lehenkari et al.
2006/0293691	A1	12/2006	Mitra et al.	2012/0271354	A1	10/2012	Baccelli et al.
2007/0055236	A1	3/2007	Hudgins et al.	2012/0277801	A1	11/2012	Marik et al.
2007/0055252	A1	3/2007	Blain et al.	2013/0023878	A1	1/2013	Belliard et al.
2007/0055373	A1	3/2007	Hudgins et al.	2013/0041410	A1	2/2013	Hestad et al.
2007/0078464	A1	4/2007	Jones et al.	2013/0079778	A1	3/2013	Azuero et al.
2007/0100452	A1	5/2007	Prosser	2013/0123923	A1	5/2013	Pavlov et al.
2007/0118218	A1	5/2007	Hooper	2013/0197643	A1	8/2013	Greenberg et al.
2007/0123863	A1	5/2007	Winslow et al.	2013/0204250	A1	8/2013	McDevitt et al.
2007/0135814	A1	6/2007	Farris	2013/0253649	A1	9/2013	Davis
2007/0149976	A1	6/2007	Hale et al.	2013/0261625	A1	10/2013	Koch et al.
2007/0179619	A1	8/2007	Grab	2013/0325065	A1	12/2013	Malandain et al.
2007/0250166	A1	10/2007	McKay	2014/0012318	A1	1/2014	Goel
2007/0270812	A1	11/2007	Peckham	2014/0018816	A1	1/2014	Fenn et al.
2008/0009866	A1	1/2008	Alamin et al.	2014/0066758	A1	3/2014	Marik et al.
2008/0046083	A1	2/2008	Hewko	2014/0214084	A1	7/2014	Jackson et al.
2008/0058929	A1	3/2008	Whelan	2014/0257397	A1	9/2014	Akbarnia et al.
2008/0082103	A1	4/2008	Hutton et al.	2014/0277149	A1	9/2014	Rooney et al.
2008/0161853	A1	7/2008	Arnold et al.	2014/0309699	A1	10/2014	Houff
2008/0177264	A1	7/2008	Alamin et al.	2014/0336653	A1	11/2014	Bromer
2008/0177326	A1	7/2008	Thompson	2014/0378976	A1	12/2014	Garcia
2008/0183209	A1	7/2008	Robinson et al.	2015/0045794	A1	2/2015	Garcia et al.

2015/0094767	A1	4/2015	Blain et al.	WO	WO 2004/071358	8/2004
2015/0119988	A1	4/2015	Assell et al.	WO	WO 2005/020850	3/2005
2015/0164652	A1	6/2015	Assell et al.	WO	WO 2005/072661	8/2005
2015/0190149	A1	7/2015	Assell et al.	WO	WO 2006/023980	3/2006
2015/0209096	A1	7/2015	Gephart	WO	WO 2006/096803	9/2006
2015/0257770	A1	9/2015	Assell et al.	WO	WO 2008/008522	1/2008
2015/0327872	A1	11/2015	Assell et al.	WO	WO 2009/013397	1/2009
2015/0342648	A1	12/2015	McCormack et al.	WO	WO 2009/015100	1/2009
2016/0113692	A1	4/2016	Knoepfle	WO	WO 2009/021876	2/2009
2016/0128838	A1	5/2016	Assell et al.	WO	WO 2010/060072	5/2010
2016/0213481	A1	7/2016	Blain	WO	WO 2010/122472	10/2010
2017/0000527	A1	1/2017	Blain et al.	WO	WO 2011/011621	1/2011
2017/0239060	A1	8/2017	Blain	WO	WO 2012/007941	1/2012
2017/0281232	A1	10/2017	Smith	WO	WO 2012/116266	8/2012
2017/0296234	A1	10/2017	Jackson et al.	WO	WO 2012/116267	8/2012
2018/0085148	A1	3/2018	Blain	WO	WO 2012/154265	11/2012
2018/0085149	A1	3/2018	Blain	WO	WO 2013/022880	2/2013
2019/0142478	A1	5/2019	Blain	WO	WO 2013/138655	9/2013
2019/0192194	A1	6/2019	Blain	WO	WO 2014/078541	5/2014
2019/0328428	A1	10/2019	Blain	WO	WO 2016/044432	3/2016
2019/0365433	A1	12/2019	Blain et al.			

## FOREIGN PATENT DOCUMENTS

CA	2 437 575	4/2009
DE	93 04 368	5/1993
DE	201 12 123	9/2001
DE	101 35 771	2/2003
EP	0 238 219	9/1987
EP	0 322 334	6/1989
EP	0 392 124	10/1990
EP	0 610 837	8/1994
EP	0 928 603	7/1999
EP	1 201 202	5/2002
EP	1 201 256	5/2002
EP	2 138 122	12/2009
EP	2 919 717	9/2015
FR	2 704 745	11/1994
FR	2 722 980	2/1996
GB	2 366 736	3/2002
JP	53-005889	1/1978
JP	62-270147	11/1987
JP	03-100154	4/1991
JP	03-240660	10/1991
JP	08-509918	10/1996
JP	10-179622	7/1998
JP	2000-201941	7/2000
JP	2000-210297	8/2000
JP	2003-079649	3/2003
JP	2004-508888	3/2004
JP	2004-181236	7/2004
JP	2006-230722	9/2006
JP	2006-528540	12/2006
JP	2007-503884	3/2007
JP	2007-517627	7/2007
JP	2007-190389	8/2007
JP	2008-510526	4/2008
JP	2008-522787	7/2008
JP	2008-537498	9/2008
JP	2009-533167	9/2009
JP	2010-510852	4/2010
JP	2010-173739	8/2010
JP	2012-509740	4/2012
JP	2012-521221	9/2012
JP	2013-534451	9/2013
JP	2014-513583	6/2014
MX	6012309	1/2007
WO	WO 93/014721	8/1993
WO	WO 94/004088	3/1994
WO	WO 97/047246	12/1997
WO	WO 98/048717	11/1998
WO	WO 99/023963	5/1999
WO	WO 00/038582	7/2000
WO	WO 00/053126	9/2000
WO	WO 01/030248	5/2001
WO	WO 02/045765	6/2002
WO	WO 02/065954	8/2002
WO	WO 02/096300	12/2002
WO	WO 03/101350	12/2003

## OTHER PUBLICATIONS

3rd Party Lab Notebook, "Facet Cartilage Repair," dated May 20, 2003 in 2 pages.

ArthroTek, "CurvTek® Bone Tunneling System," Surgical Technique, 2000, pp. 6.

ArthroTek, "CurvTek® Bone Tunneling System," User's Manual, 2000, pp. 20.

Ash, H.E., "Proximal Interphalangeal Joint Dimensions for the Design of a Surface Replacement Prosthesis", School of Engineering, University of Durham, Proceedings of the Institution of Mechanical Engineers Part H Journal of Engineering in Medicine Feb. 1996, vol. 210, No. 2, pp. 95-108.

Beaman, MD et al., "Substance P Innervation of Lumbar Spine Facet Joints", Spine, 1993, vol. 18, No. 8, pp. 1044-1049.

Butterman, et al., "An Experimental Method for Measuring Force on the Spinal Facet Joint: Description and Application of the Method", Journal of Biomechanical Engineering, Nov. 1991, vol. 113, pp. 375-386.

Cruess et al., "The Response of Articular Cartilage to Weight-Bearing Against Metal", The Journal of Bone and Joint Surgery, Aug. 1984, vol. 66-B, No. 4, pp. 592-597.

Dalldorf et al., "Rate of Degeneration of Human Acetabular Cartilage after Hemiarthroplasty", The Journal of Bone and Joint Surgery, Jun. 1995, vol. 77, No. 6, pp. 877-882.

E-mail from 3rd Party citing U.S. Appl. Nos. 60/721,909; 60/750,005 and 60/749,000, initial e-mail dated May 11, 2009, reply e-mail dated May 18, 2009.

Frost, Harold M., "From Wolff's Law to the Utah Paradigm: Insights About Bone Physiology and Its Clinical Applications", The Anatomical Record, 2001, vol. 262, pp. 398-419.

King et al., "Mechanism of Spinal Injury Due to Caudocephalad Acceleration," Symposium on the Lumbar Spine, Orthopedic Clinic of North America, Jan. 1975, vol. 6, pp. 19-31.

Kurtz PhD et al., "Isoelastic Polyaryletheretherketone Implants for Total Joint Replacement", PEEK Biomaterials Handbook, Ch. 14, 2012, pp. 221-226.

Meisel et al., "Minimally Invasive Facet Restoration Implant for Chronic Lumbar Zygapophysial Pain: 1-Year Outcomes", Annals of Surgical Innovation and Research (ASIR), 2014, vol. 8, No. 7, pp. 6.

Panjabi, PhD et al., "Articular Facets of the Human Spine: Quantitative Three-Dimensional Anatomy", Spine, 1993, vol. 18, No. 10, pp. 1298-1310.

PARTEQ Innovations, "Facet Joint Implants & Resurfacing Devices," Technology Opportunity Bulletin, Tech ID Dec. 1999, Queen's University, Ontario Canada, pp. 2.

Ravikumar et al., "Internal Fixation Versus Hemiarthroplasty Versus Total Hip Arthroplasty for Displaced Subcapital Fractures of Femur—13 Year Results of a Prospective Randomised Study", International Journal of the Care of the Injured (INJURY), 2000, vol. 31, pp. 793-797.

- Schendel et al., "Experimental Measurement of Ligament Force, Facet Force, and Segment Motion in the Human Lumbar Spine", *Journal of Biomechanics*, 1993, vol. 26, No. 4/5, pp. 427-438.
- Sharpe Products, "Metal Round Disks", <https://web.archive.org/web/20170705214756/https://sharpeproducts.com/store/metal-round-disks>, as archived Jul. 5, 2017 in 3 pages.
- Tanno et al., "Which Portion in a Facet is Specifically Affected by Articular Cartilage Degeneration with Aging in the Human Lumbar Zygapophysial Joint?", *Okajimas Folia Anatomica Japonica*, May 2003, vol. 80, No. 1, pp. 29-34.
- Official Communication in Australian Application No. 2005213459, dated Dec. 11, 2009.
- Official Communication in Australian Application No. 2005213459, dated Dec. 15, 2010.
- Official Communication in Australian Application No. 2011226832, dated Sep. 4, 2012.
- Official Communication in Australian Application No. 2011226832, dated Oct. 31, 2012.
- Official Communication in Australian Application No. 2013237744, dated Sep. 2, 2014.
- Notice of Acceptance in Australian Application No. 2013237744, dated Apr. 23, 2015.
- Official Communication in Australian Application No. 2015205875, dated Apr. 2, 2016.
- Official Communication in Australian Application No. 2015205875, dated Jun. 15, 2016.
- Official Communication in Australian Application No. 2016231622, dated Dec. 5, 2017.
- Official Communication in Australian Application No. 2016231622, dated Nov. 22, 2018.
- Notice of Acceptance in Australian Application No. 2016231622, dated Dec. 4, 2018.
- Official Communication in Australian Application No. 2019201539, dated Jun. 25, 2019.
- Official Communication in Canadian Application No. 2,555,355, dated Sep. 2, 2011.
- Official Communication in Canadian Application No. 2,803,783, dated Sep. 29, 2014.
- Official Communication in Canadian Application No. 2,803,783, dated Aug. 5, 2015.
- Official Communication in Canadian Application No. 2,803,783, dated Jul. 7, 2016.
- Official Communication in Canadian Application No. 2,803,783, dated Apr. 5, 2017.
- Official Communication in European Application No. 05712981.9, dated Jul. 24, 2007.
- Official Communication in European Application No. 05712981.9, dated Mar. 10, 2008.
- Official Communication in European Application No. 05712981.9, dated Apr. 6, 2009.
- Official Communication in European Application No. 05712981.9, dated Jun. 15, 2010.
- Official Communication in European Application No. 10178979.0, dated Mar. 14, 2011.
- Official Communication in European Application No. 10178979.0, dated Nov. 13, 2012.
- Official Communication in European Application No. 10178979.0, dated Aug. 5, 2013.
- Official Communication in European Application No. 14175088.5, dated Sep. 8, 2014.
- Official Communication in European Application No. 14175088.5, dated Nov. 18, 2015.
- Official Communication in European Application No. 16180368.9, dated Mar. 31, 2017.
- Official Communication in European Application No. 16180368.9, dated Jan. 11, 2018.
- Official Communication in European Application No. 19158915.9, dated Jul. 1, 2019.
- Official Communication in Japanese Application No. 2006-552309, dated May 25, 2010.
- Official Communication in Japanese Application No. 2006-552309, dated Feb. 15, 2011.
- Official Communication in Japanese Application No. 2010-221380, dated Feb. 15, 2011.
- Official Communication in Japanese Application No. 2012-272106, dated Dec. 3, 2013.
- Official Communication in Japanese Application No. 2012-272106, dated May 26, 2014.
- Official Communication in Japanese Application No. 2012-272106, dated Feb. 23, 2015.
- Official Communication in Japanese Application No. 2012-272106, dated Nov. 2, 2015.
- International Search Report and Written Opinion in International Application No. PCT/US2005/003753, dated Dec. 5, 2006.
- International Preliminary Report on Patentability and Written Opinion in International Application No. PCT/US2005/003753, dated Jan. 9, 2007.
- Official Communication in European Application No. 08730413.5, dated Feb. 16, 2012.
- Official Communication in European Application No. 14177951.2, dated Nov. 13, 2014.
- International Search Report and Written Opinion in International Application No. PCT/US2008/054607, dated Jul. 10, 2008.
- International Preliminary Report on Patentability and Written Opinion in International Application No. PCT/US2008/054607, dated Sep. 3, 2009.
- Official Communication in Australian Application No. 2011292297, dated Jul. 10, 2013.
- Official Communication in Australian Application No. 2014277721, dated Sep. 8, 2016.
- Official Communication in Australian Application No. 2014277721, dated Jan. 9, 2017.
- Official Communication in Canadian Application No. 2,804,223, dated Jun. 5, 2017.
- Official Communication in Canadian Application No. 2,804,223, dated Mar. 14, 2018.
- Official Communication in European Application No. 11818586.7, dated Nov. 6, 2014.
- Official Communication in European Application No. 11818586.7, dated Feb. 3, 2017.
- Official Communication in Japanese Application No. 2013-524882, dated Mar. 2, 2015.
- Official Communication in Japanese Application No. 2013-524882, dated Nov. 16, 2015.
- Official Communication in Japanese Application No. 2015-242990, dated Dec. 12, 2016.
- Official Communication in Japanese Application No. 2015-242990, dated May 8, 2017.
- Official Communication in Japanese Application No. 2015-242990, dated Aug. 21, 2017.
- International Search Report and Written Opinion in International Application No. PCT/US2011/047432, dated Dec. 12, 2011.
- International Preliminary Report on Patentability and Written Opinion in International Application No. PCT/US2011/047432, dated Feb. 28, 2013.
- Official Communication in Australian Application No. 2012222229, dated Aug. 21, 2015.
- Official Communication in Australian Application No. 2012222229, dated May 11, 2016.
- Official Communication in Australian Application No. 2012222230, dated Aug. 21, 2015.
- Official Communication in European Application No. EP12749447.4, dated Jan. 4, 2017.
- Official Communication in European Application No. EP12749447.4, dated Apr. 4, 2017.
- Official Communication in European Application No. EP12749447.4, dated Nov. 14, 2018.
- Official Communication in European Application No. 12749251.0, dated Jan. 4, 2017.
- Official Communication in European Application No. 12749251.0, dated May 9, 2017.
- Official Communication in Japanese Application No. 2013-555591, dated Jan. 4, 2016.
- Official Communication in Japanese Application No. 2016-246368, dated Oct. 30, 2017.

Official Communication in Japanese Application No. 2016-246368, dated Jul. 2, 2018.

Official Communication in Japanese Application No. 2013-555592, dated Dec. 7, 2015.

Official Communication in Japanese Application No. 2013-555592, dated Aug. 8, 2016.

Official Communication in Japanese Application No. 2013-555592, dated Jan. 5, 2018.

Official Communication in Japanese Application No. 2016-237460, dated Oct. 23, 2017.

Official Communication in Japanese Application No. 2016-237460, dated Apr. 16, 2018.

International Search Report in International Application No. PCT/US2012/026470, dated May 30, 2012.

International Preliminary Report on Patentability and Written Opinion in International Application No. PCT/US2012/026470, dated Sep. 6, 2013.

International Search Report and Written Opinion in International Application No. PCT/US2012/026472, dated Jun. 20, 2012.

International Preliminary Report on Patentability and Written Opinion in International Application No. PCT/US2012/026472, dated Mar. 12, 2014.

Official Communication in Australian Application No. 2014241989, dated Aug. 31, 2017.

Official Communication in Australian Application No. 2014241989, dated Jun. 20, 2018.

Official Communication in Australian Application No. 2014241989, dated Aug. 17, 2018.

Official Communication in European Application No. 14774714.1, dated Oct. 21, 2016.

Official Communication in European Application No. 14774714.1, dated May 23, 2019.

Official Communication in Japanese Application No. 2016-500490, dated Nov. 27, 2017.

Official Communication in Japanese Application No. 2016-500490, dated May 7, 2018.

International Search Report and Written Opinion in International Application No. PCT/US2014/019302, dated May 18, 2015.

Official Communication in Australian Application No. 2014241994, dated Oct. 30, 2017.

Official Communication in European Application No. 14776445.0, dated Nov. 7, 2016.

Official Communication in Japanese Application No. 2016-500498, dated Jan. 5, 2018.

Official Communication in Japanese Application No. 2016-500498, dated Jul. 2, 2018.

Official Communication in Japanese Application No. 2016-500498, dated Mar. 4, 2019.

International Search Report and Written Opinion in International Application No. PCT/US2014/019325, dated Jun. 17, 2014.

International Preliminary Report on Patentability and Written Opinion in International Application No. PCT/US2014/019325, dated Sep. 24, 2015.

Official Communication in Australian Application No. 2014327083, dated May 31, 2018.

Notice of Acceptance in Australian Application No. 2014327083, dated Apr. 3, 2019.

Official Communication in European Application No. 14850082.0, dated Aug. 31, 2016.

Official Communication in Japanese Application No. 2016-517392, dated Jun. 4, 2018.

Official Communication in Japanese Application No. 2016-517392, dated Apr. 22, 2019.

International Search Report and Written Opinion in International Application No. PCT/US2014/056598, dated Dec. 29, 2014.

International Preliminary Report on Patentability and Written Opinion in International Application No. PCT/US2014/056598, dated Apr. 7, 2016.

International Search Report and Written Opinion in International Application No. PCT/US2015/050441, dated Dec. 28, 2015.

International Preliminary Report on Patentability and Written Opinion in International Application No. PCT/US2015/050441, dated Mar. 30, 2017.

Official Communication in European Application No. 16743832.4, dated Jul. 24, 2018.

International Search Report and Written Opinion in International Application No. PCT/US2016/013062, dated Mar. 16, 2016.

International Preliminary Report on Patentability and Written Opinion in International Application No. PCT/US2016/013062, dated Aug. 10, 2017.

International Search Report in International Application No. PCT/CA2002/000193 filed Feb. 15, 2002, dated Jun. 18, 2002.

International Search Report and Written Opinion in International Application No. PCT/US2004/028094, dated May 16, 2005.

International Preliminary Report on Patentability and Written Opinion in International Application No. PCT/US2004/028094, dated Feb. 25, 2013.

International Search Report in International Application No. PCT/US2005/000987 filed Jan. 13, 2005, dated May 24, 2005.

International Preliminary Report on Patentability and Written Opinion in International Application No. PCT/US2005/000987 filed Jan. 13, 2005, dated Jan. 17, 2006.

Official Communication in Australian Application No. 2019201539, dated Apr. 3, 2020.

Official Communication in European Application No. 12749251.0, dated Aug. 16, 2019.

Official Communication in Australian Application No. 2018279003, dated Jan. 9, 2020.

Official Communication in Canadian Application No. 2,903,999, dated Dec. 9, 2019.

Official Communication in Australian Application No. 2014241994, dated Jan. 31, 2020.

Official Communication in Canadian Application No. 2,904,280, dated Dec. 9, 2019.

Official Communication in Japanese Application No. 2016-500498, dated Aug. 9, 2019.

Official Communication in Japanese Application No. 2016-517392, dated Dec. 2, 2019.

Official Communication in Australian Application No. 2016212009, dated Sep. 6, 2019.

Official Communication in Japanese Application No. 2017-557269, dated Oct. 21, 2019. X.

International Search Report and Written Opinion in International Application No. PCT/US2020/014985, dated Apr. 24, 2020.

\* cited by examiner

*Primary Examiner* — Charles D Hanson  
(74) *Attorney, Agent, or Firm* — Knobbe, Martens, Olson & Bear, LLP

(57) **CLAIM**

The ornamental design for an interbody bone implant, as shown and described.

**DESCRIPTION**

FIG. 1 is a front perspective view of an interbody bone implant according to an embodiment;  
FIG. 2 is a top view of the interbody bone implant illustrated in FIG. 1;  
FIG. 3 is a bottom view of the interbody bone implant illustrated in FIG. 1;  
FIG. 4 is a first side view of the interbody bone implant illustrated in FIG. 1; and,  
FIG. 5 is a second side view of the interbody bone implant illustrated in FIG. 1.  
The broken-jagged lines which define the boundary of the claimed design do not form part of the claimed design. The

broken lines are for environmental purposes only and form  
no part of the claimed design.

**1 Claim, 3 Drawing Sheets**



FIG. 1

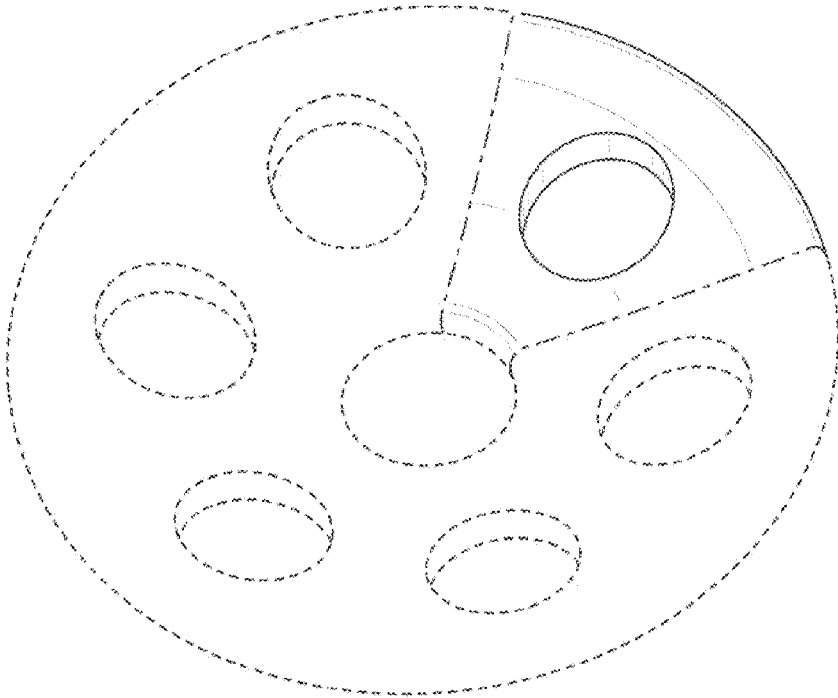

FIG. 2

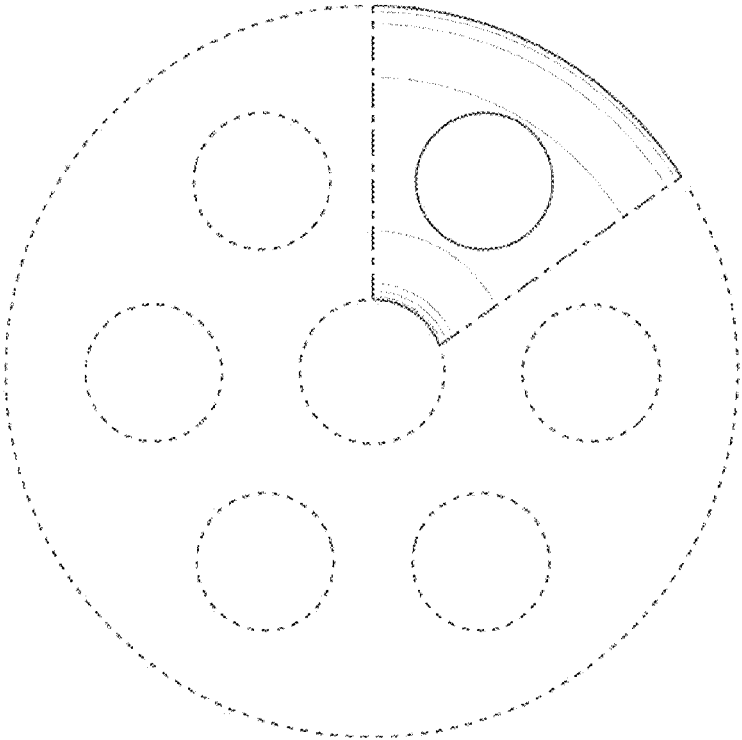

FIG. 3

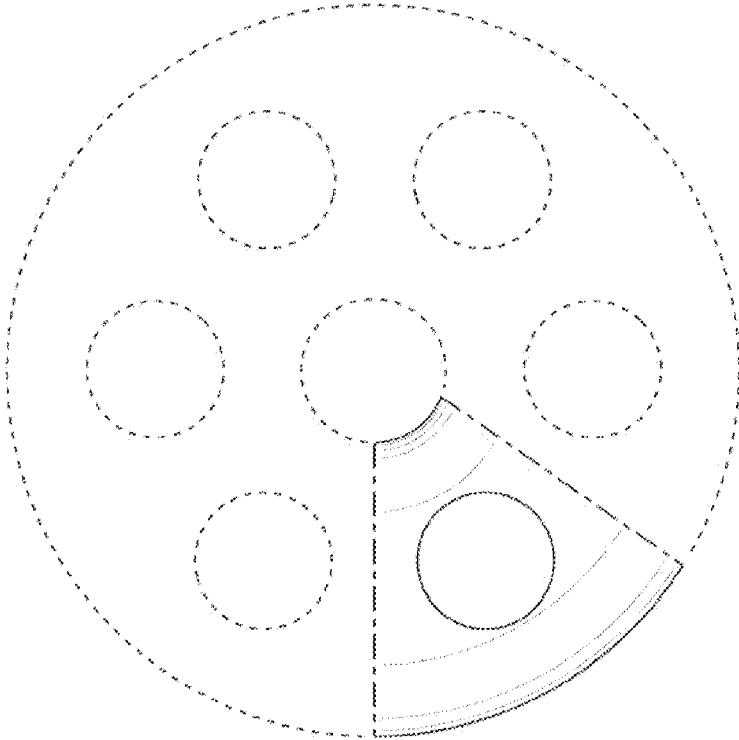

FIG. 4

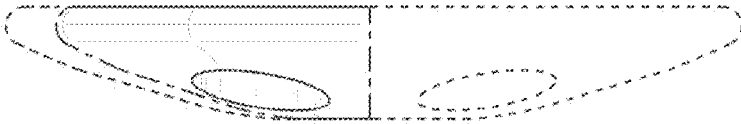

FIG. 5

