

(19) World Intellectual Property Organization  
International Bureau



(43) International Publication Date  
19 May 2011 (19.05.2011)

PCT

(10) International Publication Number  
**WO 2011/060200 A1**

(51) International Patent Classification:  
A61B 18/14 (2006.01)

(21) International Application Number:  
PCT/US2010/056424

(22) International Filing Date:  
11 November 2010 (11.11.2010)

(25) Filing Language: English

(26) Publication Language: English

(30) Priority Data:  
61/260,349 11 November 2009 (11.11.2009) US

(71) Applicants (for all designated States except US): **INNOVATIVE PULMONARY SOLUTIONS, INC.** [US/US]; 12810 Northeast 32nd Place, Bellevue, Washington 98005 (US). **MAYSE, Martin, L.** [US/US]; 7360 Teasdale Avenue, University City, Missouri 63130 (US). **DEEM, Mark** [US/US]; 685 Sierra Avenue, Mountain View, California 94041 (US). **GIFFORD, Hanson, S., III** [US/US]; 3180 Woodside Road, Woodside, California 94062 (US).

(72) Inventor; and

(75) Inventor/Applicant (for US only): **DIMMER, Steven, C.** [US/US]; 12810 Northeast 32nd Place, Bellevue, Washington 98005 (US).

(74) Agents: **KLASSEN, Karl, L.** et al.; Seed Intellectual Property Law Group PLLC, Suite 5400, 701 Fifth Avenue, Seattle, Washington 98104-7064 (US).

(81) Designated States (unless otherwise indicated, for every kind of national protection available): AE, AG, AL, AM, AO, AT, AU, AZ, BA, BB, BG, BH, BR, BW, BY, BZ, CA, CH, CL, CN, CO, CR, CU, CZ, DE, DK, DM, DO, DZ, EC, EE, EG, ES, FI, GB, GD, GE, GH, GM, GT, HN, HR, HU, ID, IL, IN, IS, JP, KE, KG, KM, KN, KP, KR, KZ, LA, LC, LK, LR, LS, LT, LU, LY, MA, MD, ME, MG, MK, MN, MW, MX, MY, MZ, NA, NG, NI, NO, NZ, OM, PE, PG, PH, PL, PT, RO, RS, RU, SC, SD, SE, SG, SK, SL, SM, ST, SV, SY, TH, TJ, TM, TN, TR, TT, TZ, UA, UG, US, UZ, VC, VN, ZA, ZM, ZW.

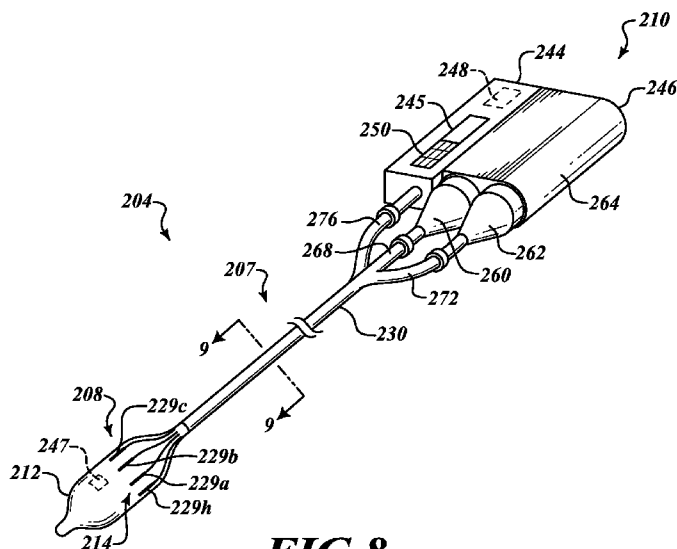
(84) Designated States (unless otherwise indicated, for every kind of regional protection available): ARIPO (BW, GH, GM, KE, LR, LS, MW, MZ, NA, SD, SL, SZ, TZ, UG, ZM, ZW), Eurasian (AM, AZ, BY, KG, KZ, MD, RU, TJ, TM), European (AL, AT, BE, BG, CH, CY, CZ, DE, DK, EE, ES, FI, FR, GB, GR, HR, HU, IE, IS, IT, LT, LU, LV, MC, MK, MT, NL, NO, PL, PT, RO, RS, SE, SI, SK, SM, TR), OAPI (BF, BJ, CF, CG, CI, CM, GA, GN, GQ, GW, ML, MR, NE, SN, TD, TG).

Published:

— with international search report (Art. 21(3))

[Continued on next page]

(54) Title: SYSTEMS, APPARATUSES, AND METHODS FOR TREATING TISSUE AND CONTROLLING STENOSIS



(57) Abstract: Systems, delivery devices, and methods to treat to ablate, damage, or otherwise affect tissue. The treatment systems are capable of delivering a coolable ablation assembly that ablates targeted tissue without damaging non-targeted tissue. The coolable ablation assembly damages nerve tissue to temporarily or permanently decrease nervous system input. The system, delivery devices, and methods can damage tissue and manage scarring and stenosis.

WO 2011/060200 A1

- *before the expiration of the time limit for amending the claims and to be republished in the event of receipt of amendments (Rule 48.2(h))*

## SYSTEMS, APPARATUSES, AND METHODS FOR TREATING TISSUE AND CONTROLLING STENOSIS

### CROSS-REFERENCE TO RELATED APPLICATION

This application claims the benefit under 35 U.S.C. § 119(e) of U.S.

- 5 Provisional Patent Application No. 61/260,349 filed November 11, 2009. This provisional application is incorporated herein by reference in its entirety.

### BACKGROUND

#### Technical Field

- The present invention generally relates to systems, apparatuses, and  
10 methods for treating tissue, and more particularly, the invention relates to systems, apparatuses, and methods for eliciting a desired response while controlling stenosis.

#### Description of the Related Art

- Pulmonary diseases may cause a wide range of problems that adversely affect performance of the lungs. Pulmonary diseases, such as asthma and chronic  
15 obstructive pulmonary disease (“COPD”), may lead to increased airflow resistance in the lungs. Mortality, health-related costs, and the size of the population having adverse effects due to pulmonary diseases are all substantial. These diseases often adversely affect quality of life. Symptoms are varied but often include cough; breathlessness; and wheeze. In COPD, for example, breathlessness may be noticed when performing  
20 somewhat strenuous activities, such as running, jogging, brisk walking, etc. As the disease progresses, breathlessness may be noticed when performing non-strenuous activities, such as walking. Over time, symptoms of COPD may occur with less and less effort until they are present all of the time, thereby severely limiting a person’s ability to accomplish normal tasks.

- 25 Pulmonary diseases are often characterized by airway obstruction associated with blockage of an airway lumen, thickening of an airway wall, alteration of structures within or around the airway wall, or combinations thereof. Airway obstruction

can significantly decrease the amount of gas exchanged in the lungs resulting in breathlessness. Blockage of an airway lumen can be caused by excessive intraluminal mucus or edema fluid, or both. Thickening of the airway wall may be attributable to excessive contraction of the airway smooth muscle, airway smooth muscle hypertrophy, 5 mucous glands hypertrophy, inflammation, edema, or combinations thereof. Alteration of structures around the airway, such as destruction of the lung tissue itself, can lead to a loss of radial traction on the airway wall and subsequent narrowing of the airway.

Asthma can be characterized by contraction of airway smooth muscle, smooth muscle hypertrophy, excessive mucus production, mucous gland hypertrophy, 10 and/or inflammation and swelling of airways. These abnormalities are the result of a complex interplay of local inflammatory cytokines (chemicals released locally by immune cells located in or near the airway wall), inhaled irritants (*e.g.*, cold air, smoke, allergens, or other chemicals), systemic hormones (chemicals in the blood such as the anti-inflammatory cortisol and the stimulant epinephrine), local nervous system input 15 (nerve cells contained completely within the airway wall that can produce local reflex stimulation of smooth muscle cells and mucous glands), and the central nervous system input (nervous system signals from the brain to smooth muscle cells and mucous glands carried through the vagus nerve). These conditions often cause widespread temporary tissue alterations and initially reversible airflow obstruction that may ultimately lead to 20 permanent tissue alteration and permanent airflow obstruction that make it difficult for the asthma sufferer to breathe. Asthma can further include acute episodes or attacks of additional airway narrowing via contraction of hyper-responsive airway smooth muscle that significantly increases airflow resistance. Asthma symptoms include recurrent episodes of breathlessness (*e.g.*, shortness of breath or dyspnea), wheezing, chest 25 tightness, and cough.

Emphysema is a type of COPD often characterized by the alteration of lung tissue surrounding or adjacent to the airways in the lungs. Emphysema can involve destruction of lung tissue (*e.g.*, alveoli tissue such as the alveolar sacs) that leads to reduced gas exchange and reduced radial traction applied to the airway wall by the 30 surrounding lung tissue. The destruction of alveoli tissue leaves areas of emphysematous lung with overly large airspaces that are devoid of alveolar walls and alveolar capillaries

and are thereby ineffective at gas exchange. Air becomes “trapped” in these larger airspaces. This “trapped” air may cause over-inflation of the lung, and in the confines of the chest restricts the in-flow of oxygen rich air and the proper function of healthier tissue. This results in significant breathlessness and may lead to low oxygen levels and high carbon dioxide levels in the blood. This type of lung tissue destruction occurs as part of the normal aging process, even in healthy individuals. Unfortunately, exposure to chemicals or other substances (*e.g.*, tobacco smoke) may significantly accelerate the rate of tissue damage or destruction. Breathlessness may be further increased by airway obstruction. The reduction of radial traction may cause the airway walls to become “floppy” such that the airway walls partially or fully collapse during exhalation. An individual with emphysema may be unable to deliver air out of their lungs due to this airway collapse and airway obstructions during exhalation.

Chronic bronchitis is a type of COPD that can be characterized by contraction of the airway smooth muscle, smooth muscle hypertrophy, excessive mucus production, mucous gland hypertrophy, and inflammation of airway walls. Like asthma, these abnormalities are the result of a complex interplay of local inflammatory cytokines, inhaled irritants, systemic hormones, local nervous system, and the central nervous system. Unlike asthma where respiratory obstruction may be largely reversible, the airway obstruction in chronic bronchitis is primarily chronic and permanent. It is often difficult for a chronic bronchitis sufferer to breathe because of chronic symptoms of shortness of breath, wheezing, and chest tightness, as well as a mucus producing cough.

Different techniques can be used to assess the severity and progression of pulmonary diseases. For example, pulmonary function tests, exercise capacity, and quality of life questionnaires are often used to evaluate subjects. Pulmonary function tests involve objective and reproducible measures of basic physiologic lung parameters, such as total airflow, lung volume, and gas exchange. Indices of pulmonary function tests used for the assessment of obstructive pulmonary diseases include the forced expiratory volume in 1 second (FEV1), the forced vital capacity (FVC), the ratio of the FEV1 to FVC, the total lung capacity (TLC), airway resistance and the testing of arterial blood gases. The FEV1 is the volume of air a patient can exhale during the first second of a forceful exhalation which starts with the lungs completely filled with air. The FEV1

is also the average flow that occurs during the first second of a forceful exhalation. This parameter may be used to evaluate and determine the presence and impact of any airway obstruction. The FVC is the total volume of air a patient can exhale during a forceful exhalation that starts with the lungs completely filled with air. The FEV1/FVC is the  
5 fraction of all the air that can be exhaled during a forceful exhalation during the first second. A FEV1/FVC ratio less than 0.7 after the administration of at least one bronchodilator defines the presence of COPD. The TLC is the total amount of air within the lungs when the lungs are completely filled and may increase when air becomes trapped within the lungs of patients with obstructive lung disease. Airway resistance is  
10 defined as the pressure gradient between the alveoli and the mouth to the rate of air flow between the alveoli and the mouth. Similarly, resistance of a given airway would be defined as the ratio of the pressure gradient across the given airway to the flow through the airway. Arterial blood gases tests measure the amount of oxygen and the amount of carbon dioxide in the blood and are the most direct method for assessing the ability of  
15 the lungs and respiratory system to bring oxygen from the air into the blood and to get carbon dioxide from the blood out of the body.

Exercise capacity tests are objective and reproducible measures of a patient's ability to perform activities. A six minute walk test (6 MWT) is an exercise capacity test in which a patient walks as far as possible over a flat surface in 6 minutes.  
20 Another exercise capacity test involves measuring the maximum exercise capacity of a patient. For example, a physician can measure the amount of power the patient can produce while on a cycle ergometer. The patient can breathe 30 percent oxygen and the work load can increase by 5-10 watts every 3 minutes.

Quality of life questionnaires assess a patient's overall health and well  
25 being. The St. George's Respiratory Questionnaire is a quality of life questionnaire that includes 75 questions designed to measure the impact of obstructive lung disease on overall health, daily life, and perceived well-being. The efficacy of a treatment for pulmonary diseases can be evaluated using pulmonary function tests, exercise capacity tests, and/or questionnaires. A treatment program can be modified based on the results  
30 from these tests and/or questionnaires.

Treatments, such as bronchial thermoplasty, involve destroying smooth muscle tone by ablating the airway wall in a multitude of bronchial branches within the lung thereby eliminating both smooth muscles and nerves in the airway walls of the lung. The treated airways are unable to respond favorably to inhaled irritants, systemic hormones, and both local and central nervous system input. Unfortunately, this destruction of smooth muscle tone and nerves in the airway wall may therefore adversely affect lung performance. For example, inhaled irritants, such as smoke or other noxious substances, normally stimulate lung irritant receptors to produce coughing and contracting of airway smooth muscle. Elimination of nerves in the airway walls removes both local nerve function and central nervous input, thereby eliminating the lung's ability to expel noxious substances with a forceful cough. Elimination of airway smooth muscle tone may eliminate the airways' ability to constrict, thereby allowing deeper penetration of unwanted substances, such as noxious substances, into the lung.

Both asthma and COPD are serious diseases with growing numbers of sufferers. Current management techniques, which include prescription drugs, are neither completely successful nor free from side effects. Additionally, many patients do not comply with their drug prescription dosage regiment. Accordingly, it would be desirable to provide a treatment which improves resistance to airflow without the need for patient compliance.

## BRIEF SUMMARY

At least some embodiments are directed to an intraluminal apparatus that denervates hollow organs while preventing, minimizing, or limiting the potential for stenosis. Targeted regions of an organ can be treated without unwanted stenosis that significantly affects organ function. In certain embodiments, the intraluminal apparatus ablates discrete targeted regions spaced apart from one another. Even if stenosis occurs, a continuous stenosis ring extending 360 degrees can be avoided. If the organ is an airway, lesions can be formed without any appreciable increase in airflow resistance.

In some embodiments, a system for treating a subject includes an elongate assembly dimensioned to move along a lumen of an airway. The assembly can attenuate signals transmitted by nerve tissue, such as nerve tissue of nerve trunks, while not

irreversibly damaging to any significant extent an inner surface of the airway. In certain embodiments, one or more electrodes output radiofrequency energy to treat a posterior 90 degrees to 180 degrees of an airway circumference to denervate a lung. A cooling systems (*e.g.*, cooling channels) can control the temperature of the electrodes and/or  
5 airway tissue while damaging the targeted tissue.

The tissue damage, in some procedures, may be sufficient to cause scarring, but the electrodes can be positioned to reduce, limit, or substantially eliminate appreciable narrowing of the airway lumen due to scar tissue, stenosis, etc. Lesions can be sufficiently spaced apart to prevent thickening of tissue between adjacent lesions. At  
10 least some embodiments disclosed herein can ablate substantially the entire circumference of an airway wall without forming a continuous ring of ablated tissue lying in a plane, which is perpendicular to a long axis of the airway.

In some embodiments, a method comprises damaging nerve tissue of a first main bronchus to substantially prevent nervous system signals from traveling to  
15 substantially all distal bronchial branches connected to the first main bronchus. Most or all of the bronchial branches distal to the first main bronchus do not receive nervous system signals. The nerve tissue, in certain embodiments, is positioned between a trachea and a lung through which the bronchial branches extend. The method further includes damaging nerve tissue of a second main bronchus to substantially prevent  
20 nervous system signals from traveling to substantially all distal bronchial branches connected to the second main bronchus. In certain embodiments, energy is delivered along less than 180° of the posterior airway or a desired portion of the airway circumference. This limits the amount of tissue that is exposed to the emitted energy.

Denervation, in some embodiments, involves the creation of lesions that  
25 affect the outside adventitial tissue layers where nerve trunks are anatomically located. In lung denervation, ablating nerve trunks which traverse along the outside of both the right and left main bronchi effectively disconnects airway smooth muscle which lines the inside of the lung airways and mucus producing glands located with the airways from the vagus nerve. When this occurs, airway smooth muscle relaxes and mucus production is  
30 decreased. These changes reduce airway obstruction under states of disease, such as



COPD and asthma. Reduced airway obstruction makes breathing easier which improves a subject's quality of life and health status.

The nerve tissue can be thermally damaged by increasing a temperature of the nerve tissue to a first temperature (*e.g.*, an ablation temperature) while the wall of the airway is at a second temperature that is less than the first temperature. In some 5 embodiments, a portion of the airway wall positioned radially inward from the nerve tissue can be at the first temperature so as to prevent permanent damage to the portion of the airway wall. The first temperature can be sufficiently high to cause permanent destruction of the nerve tissue. In some embodiments, the nerve tissue is part of a nerve 10 trunk located in connective tissue outside of the airway wall. The smooth muscle and nerve tissue in the airway wall can remain functional to maintain a desired level of smooth muscle tone. The airway can constrict/dilate in response to stimulation (*e.g.*, stimulation caused by inhaled irritants, the local nervous system, or systemic hormones). In other embodiments, the nerve tissue is part of a nerve branch or nerve fibers in the 15 airway wall. In yet other embodiments, both nerve tissue of the nerve trunk and nerve tissue of nerve branches/fibers are simultaneously or sequentially damaged. Various types of activatable elements, such as ablation elements, can be utilized to output the energy.

Some embodiments take advantage of large airway anatomy. Airway 20 nerve trunks of the vagus nerve often reside along the posterior half of the main bronchial airways. The posterior area of the main airways (*i.e.* tracheal, right and left main bronchus) does not have cartilage. The cartilage rings of these airways are not fully circumferential and only soft tissue is present along their posterior. Further, damaging nerve tissue from airway nerve trunks which reside on the posterior half of the airways 25 can be accomplished by creating lesions that are less (*e.g.*, significantly less) than the 360 degrees of the airway circumference. For example, treating 180 degrees, 150 degrees, or 130 degrees of airway circumference may be all that is required to effectively denervate the airway. Since the lesion has an arc length significantly less than 360 degrees, airway stenosis can be greatly reduced or prevented.

30 Electrodes can have complex shapes, including arcuate shapes, polygonal shapes, or have any other shapes or configurations. The electrodes can be V-shaped, U-

shaped, L-shaped, T-shaped, W-shaped, straight, curved, or combinations thereof. In some embodiments, an electrode assembly has a zigzag configuration, a serpentine configuration, a wound or coiled configuration, a corkscrew configuration, a helical configuration, z-shaped configuration, combinations thereof, or the like. A corkscrew-shaped electrode assembly can have independently operatable electrodes that form a discontinuous or continuous generally corkscrew-shaped lesion.

Another embodiment includes a continuous electrode assembly capable of creating a generally corkscrew-shaped lesion along a part or all of the airway circumference. Scars that have less surface area for the same circumferential region are less likely to generate tissue webs that can form stenosis. At least some embodiments can treat narrow target regions to form corresponding narrow lesions. A knife edge electrode assembly can perform such treatments to further reduce scar tissue.

Yet another embodiment relies on nerves, arteries, and veins tending to travel in groups throughout the human anatomy. Ultrasound or other type of energy can be used to determine the location of the bronchial arteries or veins which travel in close proximity to airway nerve trunks prior to performing airway denervation. After determining the locations of the blood vessels, the airway area in proximity to the blood vessels is treated with energy to ablate the airway nerve trunks. This technique minimizes or limits the volume of treated tissue to reduce or eliminate the risk for stenosis.

In some procedures, a catheter shapes at least one lesion at a desired depth. For example, one or more corkscrew-shaped or helical-shaped lesions can be formed in one bronchial airway wall and an arcuate lesion can be formed in another airway wall to denervate different portions of a bronchial tree. The lesions can be located along an inner surface of an airway or deep within the airway wall, or along an outer surface of the airway.

An energy delivery device, in some embodiments, comprises a catheter shaft and an ablation assembly coupled to the catheter shaft. The ablation assembly includes a cooling element movable from a collapsed state to an expanded state and an intercartilaginous energy emitter including a plurality of electrodes circumferentially offset from one another about a longitudinal axis of the ablation assembly. The

electrodes are configured to delivery energy to a plurality of target regions of an airway that are spaced apart from one another with respect to the longitudinal axis of the airway. The energy emitter and the cooling element are configured to cooperate to form intercartilaginous lesions which are spaced apart from surface tissue of the airway and  
5 positioned between cartilaginous rings of the airway.

In certain embodiments, an intraluminal delivery device comprises an ablation assembly including an expandable device and a plurality of ablation elements and/or electrodes. The electrodes are spaced apart about a circumference of the expandable member and capable of outputting energy to discrete target regions to form  
10 lesions at the target regions. At least a portion of a first lesion is axially spaced apart from and circumferentially adjacent to or overlapping a second lesion.

In some embodiment, a method of treating a subject comprises positioning an ablation assembly with respect to an airway and outputting energy from the ablation assembly to axially spaced apart target regions of the airway. The profiles of  
15 the target regions overlap when viewed in a direction along a long axis of the airway.

In yet other embodiments, a method of treating a subject comprises moving an energy emitter of a delivery device along an airway. At least one electrode of the energy emitter is positioned between cartilaginous rings of the airway. Energy is delivered from the electrode to target regions at axially separated locations along a long  
20 axis of the airway to form inter-cartilaginous lesions.

Some methods of treating tissue comprise positioning an ablation assembly in a lumen of an airway and delivering energy to tissue of the airway using at least one electrode of the ablation assembly positioned near an inner surface of the airway. Energy is delivered to damage target regions axially separated along the airway  
25 such that portions of the target regions defining maximum cross-sectional widths of the target regions are separated from the inner surface of the airway.

A delivery device, in some embodiments, comprises a catheter shaft and an ablation assembly coupled to the catheter shaft. The ablation assembly includes a deployable element movable from a collapsed state to an expanded state. An energy  
30 emitter is capable of emitting energy to produce lesions that have ends axially displaced

from one another along an axial length of a body structure when the expandable member is in the deployed state.

A delivery device can produce one or more lesions that are continuous or discontinuous. The lesions can have different shapes, including arcuate shapes, spiral  
5 shapes, helical shapes, wavy shapes, serpentine shapes, or combinations thereof. For producing continuous lesions, an ablation assembly can have electrodes spaced close together to form generally continuous lesions. Alternatively, the ablation assembly can have a long electrode or energy emitter that has corresponding spiral shapes, helical  
10 shapes, serpentine shapes, or the like. In other embodiments, electrodes can be spaced apart a sufficient distance to form discontinuous lesions. The pattern, spacing, and size of the lesions can be selected to treat target regions.

In certain embodiments, lesions can be simultaneously formed at different locations along the airway wall. In some procedures, oblique lesions can be formed at opposite sides of the airway. An entire lesion can be positioned between cartilaginous  
15 rings to avoid damaging the rings. In other embodiments, lesions can traverse tracheal or cartilaginous rings.

#### BRIEF DESCRIPTION OF THE DRAWINGS

In the Figures, identical reference numbers identify similar elements or acts.

20 Figure 1 is an illustration of lungs, blood vessels, and nerves near to and in the lungs.

Figure 2 is an illustration of an intraluminal treatment system positioned within a left main bronchus according to one embodiment.

25 Figure 3 is an illustration of a delivery device extending from an access apparatus positioned in the left main bronchus.

Figure 4A is a cross-sectional view of an airway of a bronchial tree and a collapsed ablation assembly.

Figure 4B is a cross-sectional view of an airway of a bronchial tree and an expanded ablation assembly.

Figure 5A is a cross-sectional view of an airway surrounding the collapsed ablation assembly when smooth muscle of the airway is constricted and mucus is in an airway lumen.

Figure 5B is a cross-sectional view of the airway surrounding the  
5 expanded ablation assembly.

Figure 6 is a graph of the depth of tissue versus the temperature of the tissue.

Figure 7 is a side elevational view of an ablation assembly in an airway.

Figure 8 is an isometric view of a delivery device with an ablation  
10 assembly.

Figure 9 is a cross-sectional view of an elongate shaft taken along a line 9-9 of Figure 8.

Figure 10 is a side elevational view of an ablation assembly.

Figure 11 is a longitudinal cross-sectional view of the ablation assembly  
15 of Figure 10.

Figure 12 is a partial cross-sectional view of a treatment system with a delivery device extending out of an access apparatus.

Figure 13 is a side elevational view of an ablation assembly.

Figure 14 is a cross-sectional view of an airway surrounding a deployed  
20 ablation assembly, taken along a line 14-14 of Figure 13.

Figure 15 is a side elevational view of an ablation assembly.

Figure 16 is a side elevational view of an ablation assembly for producing oblique lesions.

Figure 17 is a side elevational view of an ablation assembly with internal  
25 passageways.

Figure 18 is a cross-sectional view of the ablation assembly of Figure 17 taken along a line 18-18.

Figure 19 is a side elevational view of an ablation assembly with vents.

Figure 20 is a cross-sectional view of the ablation assembly of Figure 19  
30 taken along a line 20-20.

Figure 21 is a side elevational view of an ablation assembly with an array of V-shaped electrodes.

Figure 22 is a side elevational view of an ablation assembly with T-shaped electrodes.

5 Figure 23 is a side elevational view of a multi-tine ablation assembly.

Figure 24 is a side elevational view of an ablation assembly with a pair of electrode assemblies.

Figure 25 is a side elevational view of an ablation assembly with a coolable electrode assembly.

10 Figure 26 is a cross-sectional view of the electrode assembly taken along a line 26-26 of Figure 25.

Figures 27A-31B show isotherms and corresponding lesions.

Figure 32 is a side elevational view of a helical ablation assembly.

Figure 33 is a side elevational view of another helical ablation assembly.

15 Figure 34 is an isometric view of an ablation assembly with spaced apart electrodes.

Figure 35 is an isometric view of the ablation assembly of Figure 34 positioned in airway body lumen.

20 Figure 36 is an isometric view of lesions formed by the ablation assembly of Figure 34.

Figure 37 is an isometric view of an ablation assembly with coolant cooled electrodes.

Figure 38 is a cross-sectional view of an ablation assembly taken along a line 38-38 of Figure 37.

25 Figure 39A is an isometric view of an ablation assembly with a curved energy emitter.

Figure 39B is an isometric view of a vessel treated by the ablation assembly of Figure 39A.

30 Figure 40A is another isometric view of the ablation assembly of Figure 39A.

Figure 40B is an isometric view of the vessel treated by the ablation assembly of Figure 40A.

Figure 41 is an isometric view of an ablation assembly, in accordance with another embodiment.

5 Figure 42 is an isometric view of an ablation assembly in a delivery configuration.

Figure 43 is an isometric view of the ablation assembly of Figure 42 in deployed configuration.

10 43A is a side elevational view of the ablation assembly of Figure 43.

Figure 44 is a cross-sectional view of a distal section of the ablation assembly of Figure 43.

#### DETAILED DESCRIPTION

Figure 1 illustrates human lungs 10 having a left lung 11 and a right lung 15 12. A trachea 20 extends downwardly from the nose and mouth and divides into a left main bronchus 21 and a right main bronchus 22. The left main bronchus 21 and right main bronchus 22 each branch to form lobar, segmental bronchi, and sub-segmental bronchi, which have successively smaller diameters and shorter lengths in the outward direction (*i.e.*, the distal direction). A main pulmonary artery 30 originates at a right 20 ventricle of the heart and passes in front of a lung root 24. At the lung root 24, the artery 30 branches into a left and right pulmonary artery, which in turn branch to form a network of branching blood vessels. These blood vessels can extend alongside airways of a bronchial tree 27. The bronchial tree 27 includes the left main bronchus 21, the right main bronchus 22, bronchioles, and alveoli. Vagus nerves 41, 42 extend alongside the 25 trachea 20 and branch to form nerve trunks 45.

The left and right vagus nerves 41, 42 originate in the brainstem, pass through the neck, and descend through the chest on either side of the trachea 20. The vagus nerves 41, 42 spread out into nerve trunks 45 that include the anterior and posterior pulmonary plexuses that wrap around the trachea 20, the left main bronchus 21, 30 and the right main bronchus 22. The nerve trunks 45 also extend along and outside of

the branching airways of the bronchial tree 27. Nerve trunks 45 are the main stem of a nerve, comprising a bundle of nerve fibers bound together by a tough sheath of connective tissue.

The primary function of the lungs 10 is to exchange oxygen from air into the blood and to exchange carbon dioxide from the blood to the air. The process of gas exchange begins when oxygen rich air is pulled into the lungs 10. Contraction of the diaphragm and intercostal chest wall muscles cooperate to decrease the pressure within the chest to cause the oxygen rich air to flow through the airways of the lungs 10. For example, air passes through the mouth and nose, the trachea 20, then through the bronchial tree 27. The air is ultimately delivered to the alveolar air sacs for the gas exchange process.

Oxygen poor blood is pumped from the right side of the heart through the pulmonary artery 30 and is ultimately delivered to alveolar capillaries. This oxygen poor blood is rich in carbon dioxide waste. Thin semi-permeable membranes separate the oxygen poor blood in capillaries from the oxygen rich air in the alveoli. These capillaries wrap around and extend between the alveoli. Oxygen from the air diffuses through the membranes into the blood, and carbon dioxide from the blood diffuses through the membranes to the air in the alveoli. The newly oxygen enriched blood then flows from the alveolar capillaries through the branching blood vessels of the pulmonary venous system to the heart. The heart pumps the oxygen rich blood throughout the body. The oxygen spent air in the lung is exhaled when the diaphragm and intercostal muscles relax and the lungs and chest wall elastically return to the normal relaxed states. In this manner, air can flow through the branching bronchioles, the bronchi 21, 22, and the trachea 20 and is ultimately expelled through the mouth and nose.

Figure 2 shows a treatment system 200 capable of performing treatments to adjust air flow during expiration or inhalation, or both. To decrease airflow resistance to increase gas exchange, the treatment system 200 can be used to enlarge (*e.g.*, dilate) airways. In some procedures, nerve tissue (*e.g.*, nerve tissue) of a nerve trunk (inside or outside of the lungs), can be affected to dilate airways. The nervous system provides communication between the brain and the lungs 10 using electrical and chemical signals. A network of nerve tissue of the autonomic nervous system senses and regulates activity



of the respiratory system and the vasculature system. Nerve tissue includes fibers that use chemical and electrical signals to transmit sensory and motor information from one body part to another. For example, the nerve tissue can transmit motor information in the form of nervous system input, such as a signal that causes contraction of muscles or  
5 other responses. The fibers can be made up of neurons. The nerve tissue can be surrounded by connective tissue, *i.e.*, epineurium. The autonomic nervous system includes a sympathetic system and a parasympathetic system. The sympathetic nervous system is largely involved in “excitatory” functions during periods of stress. The parasympathetic nervous system is largely involved in “vegetative” functions during  
10 periods of energy conservation. The sympathetic and parasympathetic nervous systems are simultaneously active and generally have reciprocal effects on organ systems. While innervation of the blood vessels originates from both systems, innervation of the airways is largely parasympathetic in nature and travels between the lung and the brain in the right vagus nerve 42 and the left vagus nerve 41.

15 Any number of procedures can be performed on one or more of these nerve trunks 45 to affect the portion of the lung associated with those nerve trunks. Because some of the nerve tissue in the network of nerve trunks 45 coalesce into other nerves (*e.g.*, nerves connected to the esophagus, nerves though the chest and into the abdomen, and the like), specific sites can be targeted to minimize, limit, or substantially  
20 eliminate unwanted damage of non-targeted nerves or structures. Some fibers of anterior and posterior pulmonary plexuses coalesce into small nerve trunks which extend along the outer surfaces of the trachea 20 and the branching bronchi and bronchioles as they travel outward into the lungs 10. Along the branching bronchi, these small nerve trunks continually ramify with each other and send fibers into the walls of the airways.

25 The treatment system 200 can affect specific nerve tissue, such as vagus nerve tissue, associated with particular sites of interest. Vagus nerve tissue includes efferent fibers and afferent fibers oriented parallel to one another within a nerve branch. The efferent nerve tissue transmits signals from the brain to airway effector cells, mostly airway smooth muscle cells and mucus producing cells. The afferent nerve tissue  
30 transmits signals from airway sensory receptors, which respond to irritants, and stretch to the brain. While efferent nerve tissue innervates smooth muscle cells all the way from

the trachea 20 to the terminal bronchioles, the afferent fiber innervation is largely limited to the trachea 20 and larger bronchi. There is a constant, baseline tonic activity of the efferent vagus nerve tissues to the airways which causes a baseline level of smooth muscle contraction and mucous secretion. The treatment system 200 can affect the efferent and/or the afferent tissues to control airway smooth muscle (*e.g.*, innervate smooth muscle), mucous secretion, nervous mediated inflammation, and tissue fluid content (*e.g.*, edema). The contraction of airway smooth muscle, excess mucous secretion, inflammation, and airway wall edema associated with pulmonary diseases often results in relatively high airflow resistance causing reduced gas exchange and decreased lung performance.

In certain procedures, nerve tissue is ablated to attenuate the transmission of signals traveling along the vagus nerves 41, 42 that cause or mediate muscle contractions, mucus production, inflammation, edema, and the like. Attenuation can include, without limitation, hindering, limiting, blocking, and/or interrupting the transmission of signals. For example, the attenuation can include decreasing signal amplitude of nerve signals or weakening the transmission of nerve signals. Decreasing or stopping nervous system input to distal airways can alter airway smooth muscle tone, airway mucus production, airway inflammation, and the like, thereby controlling airflow into and out of the lungs 10. Decreasing or stopping sensory input from the airways and lungs to local effector cells or to the central nervous system can also decrease reflex bronchoconstriction, reflex mucous production, release of inflammatory mediators, and nervous system input to other cells in the lungs or organs in the body that may cause airway wall edema. In some embodiments, the nervous system input can be decreased to correspondingly decrease airway smooth muscle tone. In some embodiments, the airway mucus production can be decreased a sufficient amount to cause a substantial decrease in coughing and/or in airflow resistance. In some embodiments, the airway inflammation can be decreased a sufficient amount to cause a substantial decrease in airflow resistance and ongoing inflammatory injury to the airway wall. Signal attenuation may allow the smooth muscles to relax, prevent, limit, or substantially eliminate mucus production by mucous producing cells, and decrease inflammation. In this manner, healthy and/or diseased airways can be altered to adjust lung function. After treatment, various types of

questionnaires or tests can be used to assess the subject's response to the treatment. If needed or desired, additional procedures can be performed to reduce the frequency of coughing, decrease breathlessness, decrease wheezing, and the like.

Main bronchi 21, 22 (*i.e.*, airway generation 1) of Figures 1 and 2 can be  
5 treated to affect distal portions of the bronchial tree 27. In some embodiments, the left and right main bronchi 21, 22 are treated at locations along the left and right lung roots 24 and outside of the left and right lungs 11, 12. Treatment sites can be distal to where vagus nerve branches connect to the trachea and the main bronchi 21, 22 and proximal to the lungs 11, 12. A single treatment session involving two therapy applications can be  
10 used to treat most of or the entire bronchial tree 27. Substantially all of the bronchial branches extending into the lungs 11, 12 may be affected to provide a high level of therapeutic effectiveness. Because the bronchial arteries in the main bronchi 21, 22 have relatively large diameters and high heat sinking capacities, the bronchial arteries may be protected from unintended damage due to the treatment.

15 Figure 3 shows a delivery device in the form of a catheter system 204 extending through an access apparatus 206. The catheter system 204 can treat airways of the main bronchi 21, 22, as well as airways that are distal to the main bronchi 21, 22. An ablation assembly 208 can be positioned outside the lung within the right or left main bronchi, the lobar bronchii, or the intermediate bronchus. The intermediate bronchus is  
20 formed by a portion of the right main bronchus and the origin of the middle and lower lobar bronchii. The ablation assembly 208 can also be positioned in high generation airways (*e.g.*, airway generations >2) to affect remote distal portions of the bronchial tree 27.

The catheter system 204 can be navigated through tortuous airways to  
25 perform a wide range of different procedures, such as, for example, denervation of a portion of a lobe, an entire lobe, multiple lobes, or one lung or both lungs. In some embodiments, the lobar bronchi are treated to denervate lung lobes. For example, one or more treatment sites along a lobar bronchus may be targeted to denervate an entire lobe connected to that lobar bronchus. Left lobar bronchi can be treated to affect the left  
30 superior lobe and/or the left inferior lobe. Right lobar bronchi can be treated to affect the right superior lobe, the right middle lobe, and/or the right inferior lobe. Lobes can be

treated concurrently or sequentially. In some embodiments, a physician can treat one lobe. Based on the effectiveness of the treatment, the physician can concurrently or sequentially treat additional lobe(s). In this manner, different isolated regions of the bronchial tree can be treated.

5                    Each segmental bronchus may be treated by delivering energy to a single treatment site along each segmental bronchus. For example, energy can be delivered to each segmental bronchus of the right lung. In some procedures, ten applications of energy can treat most of or substantially all of the right lung. In some procedures, most or substantially all of both lungs are treated using less than thirty-six different  
10 applications of energy. Depending on the anatomical structure of the bronchial tree, segmental bronchi can often be denervated using one or two applications of energy.

                    Function of other tissue or anatomical features, such as the mucous glands, cilia, smooth muscle, body vessels (*e.g.*, blood vessels), and the like can be maintained when nerve tissue is ablated. Nerve tissue includes nerve cells, nerve fibers,  
15 dendrites, and supporting tissue, such as neuroglia. Nerve cells transmit electrical impulses, and nerve fibers are prolonged axons that conduct the impulses. The electrical impulses are converted to chemical signals to communicate with effector cells or other nerve cells. By way of example, a portion of an airway of the bronchial tree 27 can be denervated to attenuate one or more nervous system signals transmitted by nerve tissue.  
20 Denervating can include damaging all of the nerve tissue of a section of a nerve trunk along an airway to stop substantially all the signals from traveling through the damaged section of the nerve trunk to more distal locations along the bronchial tree or from the bronchial tree more proximally to the central nervous system. Additionally, signals that travel along nerve fibers that go directly from sensory receptors (*e.g.*, cough and irritant  
25 receptors) in the airway to nearby effector cells (*e.g.*, postganglionic nerve cells, smooth muscle cells, mucous cells, inflammatory cells, and vascular cells) will also be stopped. If a plurality of nerve trunks extends along the airway, each nerve trunk can be damaged. As such, the nerve supply along a section of the bronchial tree can be cut off. When the signals are cut off, the distal airway smooth muscle can relax leading to airway dilation,  
30 mucous cells decrease mucous production, or inflammatory cells stop producing airway wall swelling and edema. These changes reduce airflow resistance so as to increase gas

exchange in the lungs 10, thereby reducing, limiting, or substantially eliminating one or more symptoms, such as breathlessness, wheezing, chest tightness, and the like. Tissue surrounding or adjacent to the targeted nerve tissue may be affected but not permanently damaged. In some embodiments, for example, the bronchial blood vessels along the  
5 treated airway can deliver a similar amount of blood to bronchial wall tissues and the pulmonary blood vessels along the treated airway can deliver a similar amount of blood to the alveolar sacs at the distal regions of the bronchial tree 27 before and after treatment. These blood vessels can continue to transport blood to maintain sufficient gas exchange. In some embodiments, airway smooth muscle is not damaged to a significant  
10 extent. For example, a relatively small section of smooth muscle in an airway wall which does not appreciably impact respiratory function may be reversibly altered. If energy is used to destroy the nerve tissue outside of the airways, a therapeutically effective amount of energy does not reach a significant portion of the non-targeted smooth muscle tissue.

15 One of the left and right main bronchi 21, 22 is treated to treat one side of the bronchial tree 27. The other main bronchus 21, 22 can be treated based on the effectiveness of the first treatment. For example, the left main bronchus 21 can be treated to treat the left lung 11. The right main bronchus 22 can be treated to treat the right lung 12. In some embodiments, a single treatment system can damage the nerve  
20 tissue of one of the bronchi 21, 22 and can damage the nerve tissue of the other main bronchus 21, 22 without removing the treatment system from the trachea 20. Nerve tissue positioned along the main bronchi 21, 22 can thus be damaged without removing the treatment system from the trachea 20. In some embodiments, a single procedure can be performed to conveniently treat substantially all, or at least a significant portion (*e.g.*,  
25 at least 50%, 70%, 80%, 90% of the bronchial airways), of the patient's bronchial tree. In other procedures, the treatment system can be removed from the patient after treating one of the lungs 11, 12. If needed, the other lung 11, 12 can be treated in a subsequent procedure.

30 Figure 4A is a transverse cross-sectional view of a healthy airway 100, illustrated as a bronchial tube. The inner surface 102 is defined by a folded layer of epithelium 110 surrounded by stroma 112a. A layer of smooth muscle tissue 114

surrounds the stroma 112a. A layer of stroma 112b is between the muscle tissue 114 and connective tissue 124. Mucous glands 116, cartilage plates 118, blood vessels 120, and nerve fibers 122 are within the stroma layer 112b. Bronchial artery branches 130 and nerve trunks 45 are exterior to a wall 103 of the airway 100. The illustrated arteries 130  
5 and nerve trunks 45 are within the connective tissue 124 surrounding the airway wall 103 and can be oriented generally parallel to the airway 100. In Figure 1, for example, the nerve trunks 45 originate from the vagus nerves 41, 42 and extend along the airway 100 towards the air sacs. The nerve fibers 122 are in the airway wall 103 and extend from the nerve trunks 45 to the muscle tissue 114. Nervous system signals are transmitted  
10 from the nerve trunks 45 to the muscle 114 and mucous glands 116 via the nerve fibers 122. Additionally, signals are transmitted from sensory receptors (*e.g.*, cough, irritant, and stretch) through the nerve trunks 45 to the central nervous system.

Cilia can be damaged, excited, or otherwise altered to elicit a desired response along the epithelium 110 in order to control (*e.g.*, increase or decrease)  
15 mucociliary transport. Many particles are inhaled as a person breathes, and the airways function as a filter to remove the particles from the air. The mucociliary transport system functions as a self-cleaning mechanism for all the airways throughout the lungs  
10. The mucociliary transport is a primary method for mucus clearance from distal portions of the lungs 10, thereby serving as a primary immune barrier for the lungs 10.  
20 For example, the inner surface 102 of Figure 4A can be covered with cilia and coated with mucus. As part of the mucociliary transport system, the mucus entraps many inhaled particles (*e.g.*, unwanted contaminants such as tobacco smoke) and moves these particles towards the larynx. The ciliary beat of cilia moves a continuous carpet of mucus and entrapped particles from the distal portions of the lungs 10 past the larynx and  
25 to the pharynx for expulsion from the respiratory system. The ablation assembly 208 can damage the cilia to decrease mucociliary transport or excite the cilia to increase mucociliary transport.

The ablation assembly 208 is moved to the expanded state of Figure 4B to selectively treat target regions inside of the airway wall 103 (*e.g.*, anatomical features in  
30 the stromas 112a, 112b, the nerve trunk 45, etc.). For example, the mucous glands 116 can be damaged to reduce mucus production a sufficient amount to prevent the

accumulation of mucus that causes increased airflow resistance while preserving enough mucus production to maintain effective mucociliary transport, if needed or desired.

Nerve branches/fibers passing through the airway wall 103 or other anatomical features in the airway wall 103 can also be destroyed. The lesions are formed at specific

5 locations to prevent stenosis or scar tissue that would significantly reduce the airflow through the airway 100.

Natural body functions can help prevent, reduce, or limit damage to tissue. Blood within the blood vessels 130 can absorb thermal energy and can then carry the thermal energy away from the heated section of the branches 130. In this manner,

10 blood can mitigate or avoid damage to the blood vessels 130. After the treatment is performed, the bronchial artery branches 130 can continue to maintain the health of lung tissue. In some RF ablation embodiments, the ablation assembly 208 outputs a sufficient amount of RF energy to destroy an entire longitudinal section of the nerve trunk 45 without destroying the blood vessels 130.

15 Treatment efficacy can be evaluated based at least in part on one or more airway attributes, pulmonary function tests, exercise capacity tests, and/or questionnaires. Subjects can be evaluated to track and monitor their progress. If needed or desired, additional procedures can be performed until desired responses are achieved. Different types of instruments for evaluating airway attributes may be used. During  
20 ablation, feedback from an instrument can indicate whether the targeted tissue has been ablated. Once targeted tissue is ablated, therapy can be discontinued to minimize or limit collateral damage, if any, to healthy untargeted tissue.

Different attributes of airways can be evaluated to determine procedures to be performed. Such airway attributes include, without limitation, physical properties  
25 of airways (*e.g.*, airway compliance, contractile properties, etc.), airway resistance, dimensions of airway lumens (*e.g.*, shapes of airways, diameters of airways, etc.), responsiveness of airways (*e.g.*, responsiveness to stimulation), muscle characteristics (*e.g.*, muscle tone, muscle tension, etc.), inflammatory cells, inflammatory cytokines, or the like. In some embodiments, changes of airway muscle characteristics can be  
30 monitored by measuring pressure changes in the ablation assembly 208, which is inflated to a known pressure. Based on pressure changes, a physician determines the effects, if

any, of the treatment, including, without limitation, whether targeted tissue has been stimulated, ablated, or the like.

Figures 5A and 5B are transverse cross-sectional views of a portion of the airway 100 that has smooth muscle tissue 114 in a contracted state, mucus 150 from hypertrophied mucous glands 116, and inflammatory swelling and edema fluid thickening the airway wall 103. The contracted muscle tissue 114, the mucus 150, and thickened airway wall 103 cooperate to partially obstruct the lumen 101 resulting in a relatively high air flow resistance. The nerve tissue 45 is damaged to relax the muscle tissue 114 to dilate the airway 100 to reduce air flow resistance, thereby allowing more air to reach the alveolar sacs for the gas exchange process. Decreases in airway resistance may indicate that passageways of airways are opening, for example in response to attenuation of nervous system input to those airways. Stenosis can be limited or minimized to ensure that airway resistance does not significantly increase after treatment. Thus, the treatment ensures that there is a permanent decrease in airway flow resistance even after a significant length of time after treatment.

The decrease of airway resistance associated with treating low generation airways (*e.g.*, main bronchi, lobar bronchi, segmental bronchi) may be greater than the amount of decrease of airway resistance associated with treating high generation airways (*e.g.*, subsegmental bronchioles). A physician can select appropriate airways for treatment to achieve a desired decrease in airway resistance and can be measured at a patient's mouth, a bronchial branch that is proximate to the treatment site, a trachea, or any other suitable location. The airway resistance can be measured before performing the therapy, during the therapy, and/or after the therapy. In some embodiments, airway resistance is measured at a location within the bronchial tree by, for example, using a vented treatment system that allows for respiration from areas that are more distal to the treatment site.

The ablation assembly 208 can use energy to ablate the nerves 45 to permanently dilate the airway 100. As used herein, the term "energy" is broadly construed to include, without limitation, thermal energy, cryogenic energy (*e.g.*, cooling energy), electrical energy, acoustic energy (*e.g.*, ultrasonic energy), radio frequency energy, pulsed high voltage energy, mechanical energy, ionizing radiation, optical energy



(*e.g.*, light energy), and combinations thereof, as well as other types of energy suitable for treating tissue. In some embodiments, the catheter system 204 delivers energy and also one or more substances (*e.g.*, radioactive seeds, radioactive materials, etc.), treatment agents, and the like. Exemplary non-limiting treatment agents include, without  
5 limitation, one or more antibiotics, anti-inflammatory agents, pharmaceutically active substances, bronchoconstrictors, bronchodilators (*e.g.*, beta-adrenergic agonists, anticholinergics, etc.), nerve blocking drugs, photoreactive agents, or combinations thereof. For example, long acting or short acting nerve blocking drugs (*e.g.*, anticholinergics) can be delivered to the nerve tissue to temporarily or permanently  
10 attenuate signal transmission. Substances can also be delivered directly to the nerves 122 or the nerve trunks 45, or both, to chemically damage the nerve tissue.

Figures 6 and 7 show the effect produced by superficial and deep heating by RF energy and superficial cooling by circulating coolant in the ablation assembly 208. The coolant absorbs thermal energy such that the tissue touching a cooling section 209 of  
15 the ablation assembly 208 is cooled. The cooling section 209 can absorb a sufficient amount of thermal energy from the airway wall 100 to limit or prevent damage to tissue between the ablation assembly 208 and the nerve or other targeted tissue.

Figure 6 shows a graph with a horizontal axis corresponding to the depth into the tissue of the airway wall from the point of contact with or proximate to an  
20 electrode assembly 214 in millimeters with a vertical axis corresponding to the temperature of the tissue in degrees Centigrade. Temperatures in the figures are in degrees Centigrade, unless indicated otherwise. The point "0" on the graph corresponds to the point or area of contact between the electrode assembly 214 and the tissue of the airway wall. Three curves A, B, and C are shown in the graph and correspond to three  
25 different power levels of radio frequency energy being delivered into the tissue. The temperature on the graph is up to about 100°C. The temperature of about 100°C, or slightly less, has been shown because it is considered to be an upper limit for tissue temperature during RF ablation. At approximately 90°C, tissue fluids begin to boil and tissue coagulates and chars, thereby greatly increasing its impedance and compromising  
30 its ability to transfer RF energy into the tissue of the airway wall. Thus, it may be desirable to have tissue temperatures remain below about 90°C. At about 50°C, a line

216 represents the temperature above which tissue cell death occurs and below which tissues suffer no substantial long term effects (or any long term effects).

Curve A shown in Figure 6 represents what occurs with and without cooling of the electrode assembly 214 at a relatively low power level, for example, about 10 watts of RF energy. Curve A is divided into three segments A1, A2, and A3. The broken line segment A2 represents a continuation of the exponential curve A3 when no cooling is applied. As can be seen by curve A, the temperature of the electrode-tissue interface without cooling reaches 80°C and decreases exponentially as the distance into the tissue of the airway 100 increases. As shown, the curve A3 crosses the 50°C tissue cell death boundary represented by the line 216 at a depth of about 5 millimeters. Thus, without electrode cooling, the depth of cell death that would occur would be approximately 5 millimeters as represented by the distance d1. Further cell death would stop at this power level.

If active cooling is employed, the temperature drops to a much lower level, for example, about 35°C as represented by the curve A1 at the electrode-tissue interface at 0 millimeters in distance. Since this temperature is below 50°C, cell death will not begin to occur until a distance of d2 at the point where the curve A2 crosses the cell death line at 50°C, for example, a depth of 3 millimeters from the surface. Cell death will occur at depths from 3 millimeters to 5 millimeters as represented by the distance d3. Such a cooled ablation procedure is advantageous because it permits cell death and tissue destruction to occur at a distance (or a range of distances) from the electrode-tissue interface without destroying the epithelium and the tissue immediately underlying the same. In some embodiments, the nerve tissues running along the outside of the airway can be ablated without damaging the epithelium or underlying structures, such as the stroma and smooth muscle cells.

The curve B represents what occurs with and without cooling of the electrode at a higher power level, for example, 20 watts of RF energy. Segment B2 of curve B represents a continuation of the exponential curve of the segment B3 without cooling. As can be seen, the temperature at the electrode-tissue interface approaches 100°C which may be undesirable because that is a temperature at which boiling of tissue fluid and coagulation and charring of tissue at the tissue-electrode interface will occur,

thus making significantly increasing the tissue impedance and compromising the ability to deliver additional RF energy into the airway wall. By providing active cooling, the curve B1 shows that the temperature at the electrode-tissue interface drops to approximately 40°C and that cell death occurs at depths of two millimeters as represented by d4 to a depth of approximately 8 millimeters where the curve B3 crosses the 50°C tissue cell death boundary. Thus, it can be seen that it is possible to provide a much deeper and larger region of cell death using the higher power level without reaching an undesirable high temperature (*e.g.*, a temperature that would result in coagulation and charring of tissue at the electrode-tissue interface). The systems can be used to achieve cell death below the epithelial surface of the airway so that the surface need not be destroyed, thus facilitating early recovery by the patient from a treatment.

The curve C represents a still higher power level, for example, 40 watts of RF energy. The curve C includes segments C1, C2, and C3. The broken line segment C2 is a continuation of the exponential curve C3. Segment C2 shows that the temperature at the electrode-tissue interface far exceeds 100°C and would be unsuitable without active cooling. With active cooling, the temperature at the electrode-tissue interface approaches 80°C and gradually increases and approaches 95°C and then drops off exponentially to cross the 50°C cell death line 216 at a distance of about 15 millimeters from the electrode-tissue interface at the epithelial surface of the airway represented by the distance d6. Because the starting temperature is above the 50°C cell death line 216, tissue cell death will occur from the epithelial surface to a depth of about 15 millimeters to provide large and deep regions of tissue destruction.

Figure 7 shows a cross-sectional temperature profile in a section of the airway wall through which the RF energy is delivered to ablate tissue. The terms "ablate" or "ablation," including derivatives thereof, include, without limitation, substantial altering of electrical properties, mechanical properties, chemical properties, or other properties of tissue. Ablation can involve destroying or permanently damaging, injuring, or traumatizing tissue. For example, ablation may include localized tissue destruction, cell lysis, cell size reduction, necrosis, or combinations thereof. In the context of pulmonary ablation applications, the term "ablation" includes sufficiently

altering nerve tissue properties to substantially block transmission of electrical signals through the ablated nerve tissue.

5 Isothermal curves show the temperatures that are reached at the electrode assembly 214 and at different depths into the airway wall 100 from the electrode-tissue interface 215 when power is applied to the electrode assembly 214 and coolant (*e.g.*, a room temperature saline solution or iced saline) is delivered to the balloon 212. The term "element" in the context of "expandable element" or "deployable element" includes a discrete element or a plurality of discrete elements. By way of example, an expandable element can be a single balloon or a plurality of balloons in fluid communication with  
10 one another.

By adjusting the rate of power delivery to the electrode assembly 214, the rate at which coolant is passed into the balloon 212, and the temperature of the coolant, and the size of the balloon 212, the isotherms can be modified. By selecting the proper temperature and flow rate of coolant and the rate of power delivery to the electrode  
15 assembly 214, it is possible to achieve temperatures in which isotherm A = 60°C, B = 55°C, C = 50°C, D = 45°C, E = 40°C, and F = 37°C. Further adjustments make it possible to achieve temperatures where isotherm A = 50°C, B = 47.5°C, C = 45°C, D = 42.5°C, E = 40°C, and F = 37°C. Only those areas contained within the 50°C isotherm will be heated enough to induce cell death. In some procedures, tissue at a depth of  
20 about 2 mm to about 8 mm in the airway wall can be ablated while other non-targeted tissues at a depth less than 2 mm in the airway wall are kept at a temperature below at temperature that would cause cell death.

With reference to Figure 8, the catheter system 204 includes a control module 210 coupled to a catheter 207 having an elongate shaft 230. The balloon 212 can  
25 be inflated from a collapsed state to the illustrated expanded state. As the balloon 212 inflates, the electrode assembly 214 can be moved towards an airway wall. The inflated balloon 212 can help hold the electrode assembly 214 near (*e.g.*, proximate to or in contact with) tissue through which energy is delivered. Coolant can absorb thermal energy to cool the balloon 212 or the electrode assembly 214, or both.

30 The control module 210 generally includes a controller 244 and a fluid delivery system 246. The controller 244 includes, without limitation, one or more

processors, microprocessors, digital signal processors (DSPs), field programmable gate arrays (FPGA), and/or application-specific integrated circuits (ASICs), memory devices, buses, power sources, and the like. For example, the controller 244 can include a processor in communication with one or more memory devices. Buses can link an  
5 internal or external power supply to the processor. The memories may take a variety of forms, including, for example, one or more buffers, registers, random access memories (RAMs), and/or read only memories (ROMs). The controller 244 may also include a display 245, such as a screen, and an input device 250. The input device 250 can include a keyboard, touchpad, or the like and can be operated by a user to control the catheter  
10 207.

The controller 244 can store different programs. A user can select a program that accounts for the characteristics of the tissue and desired target region. For example, an air-filled lung can have relatively high impedance, lymph nodes can have medium impedance, and blood vessels can have relatively low impedance. The  
15 controller 244 can determine an appropriate program based on the impedance. Performance can be optimized based on feedback from sensors that detect temperatures, tissue impedance, or the like. For example, the controller 244 can control operation of the ablation assembly 208 based on tissue temperatures. If the tissue surface temperature becomes excessively hot, cooling can be increased and/or electrode power decreased in  
20 order to produce deep lesions while protecting surface tissues.

An internal power supply 248 (illustrated in dashed line in Figure 8) can be an energy generator, such as a radiofrequency (RF) electrical generator. RF energy can be outputted at a desired frequency. Example frequencies include, without  
25 limitation, frequencies in a range of about 50 KHZ to about 1,000 MHZ. When the RF energy is directed into tissue, the energy is converted within the tissue into heat causing the temperature of the tissue to be in the range of about 40°C to about 99°C. The RF energy can be applied for about 1 second to about 120 seconds. In some embodiments, the RF generator 248 has a single channel and delivers approximately 1 to 25 watts of RF energy and possesses continuous flow capability. Other ranges of frequencies, time  
30 intervals, and power outputs can also be used. Alternatively, the internal power supply 248 can be an energy storage device, such as one or more batteries. Electrical energy can

be delivered to the electrode assembly 214, which converts the electrical energy to RF energy or another suitable form of energy. Other forms of energy that may be delivered include microwave, ultrasound, direct current, or electromagnetic energy. Alternatively, cryogenic ablation may be utilized. Fluid at cryogenic temperatures can be delivered  
5 through the shaft 230 to cool a cryogenic heat exchanger on the ablation assembly 208.

The fluid delivery system 246 includes a fluid source 260 coupled to a supply line 268 and a fluid receptacle 262 coupled to a return line 272. The fluid source 260 can include a container (*e.g.*, a bottle, a canister, a tank, or other type of vessel for holding fluid) held in a housing unit 264. In pressurizable embodiments, the fluid source  
10 260 includes one or more pressurization devices (*e.g.*, one or more pumps, compressors, or the like) that pressurize coolant. Temperature control devices (*e.g.*, Peltier devices, heat exchangers, or the like) can cool or recondition the fluid. The fluid can be a coolant comprising saline, de-ionized water, refrigerant, cryogenic fluid, gas, or the like. In  
other embodiments, the fluid source 260 can be an insulated container that holds and  
15 delivers a chilled coolant to the supply line 268. The coolant flows distally through the elongate shaft 230 along a delivery lumen 326 and fills the ablation assembly 208. Coolant from the ablation assembly 208 flows proximally through the elongate shaft 230 via the return lumen 324 and ultimately flows into the receptacle 262.

A sensor 247 (illustrated in dashed line) is communicatively coupled to  
20 the controller 244. The controller 244 can command the catheter 207 based on signals from the sensor 247 (*e.g.*, a pressure sensor, a temperature sensor, a thermocouple, a pressure sensor, a contact sensor, or the like). Sensors can also be positioned on the electrode assembly 214, along the elongate shaft 230, or at any other location. In a closed loop mode of operation, the electrical energy can be delivered to the electrode  
25 assembly 214 based upon feedback signals from the sensor 247, which can be configured to transmit (or send) one or more signals indicative of one or more tissue characteristics, energy distribution, tissue temperatures, or any other measurable parameters of interest. Based on those readings, the controller 244 adjusts operation of the electrode assembly 214. In an open loop mode of operation, operation of the electrode assembly 214 can be  
30 set by user input. For example, the user can observe tissue temperature or impedance readings and manually adjust the power level. Alternatively, the power can be set to a

fixed power mode. In yet other embodiments, the catheter system 204 can switch between a closed loop mode of operation and an open loop mode of operation.

Referring to Figures 8 and 9, the elongate shaft 230 includes a power line lumens 320a-h, the delivery lumen 326, and the return lumen 324. Power lines 280a-280h (collectively "280") extend through the power line lumens 320a-320h (collectively "320"), respectively, and couple the controller 244 to the electrode assembly 214. The elongate shaft 230 can be made, in whole or in part, of one or more metals, alloys (*e.g.*, steel alloys such as stainless steel), plastics, polymers, and combinations thereof, as well as other biocompatible materials, and can be flexible to pass conveniently along highly branched airways.

Referring to Figures 10 and 11, power lines 280 deliver energy from the power supply 248 to the electrode assembly 214. In some embodiments, the power lines 280 pass through the chamber 234 and the outer wall of the balloon 212. In other embodiments, connectors for the electrode assembly 214 are positioned within the chamber 234. The power lines 280 can extend between the connectors and the elongated shaft 230 to avoid exposure to bodily fluid.

The electrode assembly 214 can include, without limitation, monopolar electrodes, bipolar electrodes, metal electrodes, wire electrodes, needle electrodes, or the like and can form an array of circumferential lesions, each extending along only a portion of a circumference of a vessel or body structure. If the body structure is an airway, each of the lesions can at least partially surround a lumen of the airway. The lesions can have an arc length of less than 360 degrees (*e.g.*, about 25 degrees to about 45 degrees). In some embodiments, the lesions are spaced apart with respect to a longitudinal axis of the body structure. Together, the lesions cover the desired circumference. For example, the lesion can overlap circumferentially (*e.g.*, when viewed along an axial length of the body structure) with the beginning of the next lesion while being longitudinally spaced apart from one another, thereby ensuring the entire circumference of the airway (or portion thereof) has been treated.

The electrode assembly 214 includes electrodes 229 circumferentially spaced apart about the balloon 212. Each electrode 229 has a pair of exposed electrode elements. An electrode element 231d of electrode 229d and an element 231e of an

adjacent electrode 229e can cooperate to form an RF arc that ablates radially adjacent tissue. The electrodes 229 can be coupled to an exterior surface of the balloon 212. In other embodiments, the electrodes 229 can be embedded in the sidewall of the balloon 212 or otherwise fixed to the balloon 212.

5 Adjacent electrodes 229 may be operated in a bipolar manner, wherein one electrode is positive and the other electrode is negative, such that RF power is transmitted through the tissue. If the electrodes 229 are monopolar electrodes, the electrodes can be coupled to separate power lines 280 to allow for independent control of each electrode. Alternatively, the electrodes 229 may be coupled to the same power line  
10 so as to be operated together.

The balloon 212 can be made, in whole or in part, of polymers, plastics, silicon, rubber, polyethylene, polyvinyl chloride, chemically inert materials, non-toxic materials, electrically insulating materials, combinations thereof, or the like. To enhance heat transfer, the balloon sidewall can comprise one or more conductive materials with a  
15 high thermal conductivity. For example, conductive strips (*e.g.*, metal strips) can help conduct thermal energy away from hot spots, if any. The balloon 212 can conform to irregularities on the airway surface (*e.g.*, cartilaginous rings, side branches, etc.) and can be made, in whole or in part, of a distensible material, such as polyurethane (*e.g.*, low durometer polyurethane) or other type of highly conformable material that may be  
20 transparent, semi-transparent, or opaque. The balloon 212 can have different inflated shapes, including a hot dog shape, an ovoid shape, a cylindrical shape, or the like. To treat a bronchial tree of a human, the diameter D of the inflated balloon 212 can be in a range of about 12 mm to about 18 mm. For enhanced treatment flexibility, the inflated balloon diameter may be in a range of about 5 mm to about 25 mm. The balloon 212 can  
25 be sized to treat other organs or tissue of other animals. To inflate the balloon 212, fluid is delivered along the delivery lumen 326 and through an inlet port 225, as shown in Figure 11. The coolant circulates within the chamber 234 and then flows proximally along the return lumen 324.

Figures 12 and 13 show one exemplary method of using the treatment  
30 system 200. The airway 100 can be viewed to locate and evaluate the treatment site(s) and non-targeted tissues before, during, and/or after performing a therapy. The access



apparatus 206 can be a guide tube, a delivery sheath, a bronchoscope, or an endoscope and can include one or more viewing devices, such as optical viewing devices (*e.g.*, cameras), optical trains (*e.g.*, a set of lens), and the like. Different regions about the circumference the airway can be stimulated (*e.g.*, electrically stimulated) to locate the  
5 position of the airway nerve trunk(s) or conditions. Detection of bronchoconstriction may be accomplished by measuring airway smooth muscle contraction distal to the point along the airway length that stimulation is performed. Muscle contraction can be measured by monitoring changes in the pressure of an inflated balloon or other type of sensor that is proximate to or in contact with the airway. This technique can minimize or  
10 limit the circumferential area of the airway that is treated to reduce or eliminate the risk of airway stenosis. The nerve locations can be determined by measuring nerve electrical signals at points along the airway circumference to locate the position of the airway nerves. An airway nerve signal stimulant, such as cold air, histamine or phenyl diguanide may be used to increase the nerve signal amplitude to facilitate airway nerve  
15 signal localization around the airway circumference.

When the access apparatus 206 of Figure 12 is moved along a body lumen, the collapsed ablation assembly 208 is held within a working channel 386. The ablation assembly 208 is moved distally out of the working lumen 386 and is inflated to move the electrode assembly 214 near (*e.g.*, proximate to or in contact with) the airway  
20 wall. RF energy can travel through tissue to heat tissue (*e.g.*, superficial and deep tissue) to form lesions at targeted regions. The targeted regions and associated lesion generally correspond to the dashed lines in Figures 13 and 14.

The term “lesion” as used herein refers to tissue which is permanently damaged, *i.e.* to the point of cell death. In some cases, the delivery of energy will cause  
25 temporary or non-lethal damage to cells outside the region referred to as the “lesion.” For example, epithelial or smooth muscle cells may be temporarily damaged or altered by the energy delivery described herein. However, advantageously, through the use of differential cooling, these cells can recover and remain functional and, thus, are not considered part of the “lesion.” By contrast, the ablation assembly 208 can permanently  
30 damage to nerve tissues or other targeted tissue lying deep in the airway wall or on the

outside of the airway wall, thus attenuating nerve signals that are the cause of certain pulmonary conditions.

The cooling section 209 of Figure 13 contacts the airway wall 100 so as to cool tissue while energy is outputted by the electrode assembly 214. The net effect of this superficial and deep heating by RF energy and superficial cooling by the circulating coolant is the concentration of heat in the outer layers of the airway wall 100. The temperature of the connective tissue can be higher than the temperatures of the epithelium, stroma, and/or smooth muscle. By example, the temperature of the connective tissue can be sufficiently high to cause damage to the nerve trunk tissue or other deep tissue while other non-targeted tissues of the airway are kept at a lower temperature to prevent or limit damage to the non-targeted tissues.

Figures 13 and 14 show eight separate lesions 237a-h (collectively "237"). Adjacent lesions 237 are axially offset from one another along a longitudinal axis 233 of the ablation assembly 208. Each lesion 237 can have an arc length of about 45 degrees such that the array of lesions extends about substantially the entire circumference of the airway wall 100, as shown in Figure 14. The length of the exposed electrode elements corresponds to the widths of the lesions 237. The lengths of exposed electrode elements (e.g., the length of electrode elements 231d, 231e) can be selected based on the desired width of the lesions 237. Advantageously, the lesions 237 can be formed simultaneously. For example, all or a substantial portion of the lesions 237 can be formed at the same time to avoid having to move the ablation assembly between ablation treatments. In other embodiments, different electrodes 229 can be activated to sequentially form lesions. The electrode assembly 214 can be moved to different locations to ablate different tissue. As such, one or more lesions can be performed simultaneously or sequentially based on the desired treatment.

With conventional ablation catheters, the ablating process may be sufficient to cause scarring which may cause local airway narrowing or stenosis. Because lesions 237 are at different locations along the length of the airway, the effects of stenosis can be mitigated. The illustrated embodiment is well suited to denervate the airway while avoiding the formation of a continuous ring of scar tissue. A continuous ring of scar tissue extending 360 degrees about the inner circumference of the airway 100

may significantly decrease the cross-sectional area of the airway lumen, thereby significantly increasing airflow resistance. The staggered lesions 237 help mitigate the reduction of the cross-sectional area of the airway lumen.

Figure 14 shows the location of the lesions 237. A projection of the outer profiles of the lesions 237 along a long axis of the airway 100 and onto an imaginary plane perpendicular to the long axis can define a substantially continuous closed ring, as shown in Figure 14. Because nerve trunks 45 extend longitudinally along the airway 100, the lesions 237 can be at a depth sufficient to ensure that all of the nerve trunks are ablated. In other embodiments, the electrode assembly 214 can be used to treat only a portion of the airway circumference, e.g. 180 degrees, 150 degrees, or 130 degrees of the airway circumference. That may be all that is required to effectively denervate the airway 100. Accordingly, nervous signals can be effectively cut off without forming a lesion that extends about the entire airway wall and can further reduce the formation of stenosis.

During RF ablation, heat can be concentrated in one or more of the internal layers (*e.g.*, the stroma) of the airway wall or in the inner lining (*e.g.*, the epithelium) of the airway wall. Furthermore, one or more of the vessels of the bronchial artery branches may be within the lesion. The heat generated using the electrode 214 can be controlled such that blood flowing through the bronchial artery branches protects those branches from thermal injury while nerve trunk tissue is damaged, even if the nerve tissue is next to the artery branches. The catheter 207 can produce relatively small regions of cell death. For example, a 2 mm to 3 mm section of tissue in the middle of the airway wall 100 or along the outer surface of the airway wall 100 can be destroyed. By the appropriate application of power and the appropriate cooling, lesions can be created at any desired depth.

Airway cartilage rings or cartilage layers typically have a significantly larger electrical resistance than airway soft tissue (*e.g.*, smooth muscle or connective tissue). Airway cartilage impedes energy flow (*e.g.*, electrical radiofrequency current flow) and makes the formation of therapeutic lesions with radiofrequency electrical energy to affect airway nerve trunk(s) challenging when the electrode is next to cartilage.

The illustrated energy emitter 214 can function as an intercartilaginous energy emitter. The electrode elements 227 may be dimensioned to generally coincide with the spacing of the cartilaginous rings 235a, 235b (collectively "235"). As shown in Figure 13, each electrode element 227 is disposed between two adjacent rings 235a, 235b such that the lesions 237 are positioned entirely within the space 333 between the cartilage rings 235.

The electrodes 229 can serve as intercartilaginous positioners that help preferentially seat the electrode elements 227 in the space 333, thus making it easy to perform the treatment or to verify correct positioning. For example, the electrode elements 227 can protrude outwardly and tend to move into and fit into the regions of softer, more compliant tissue in the space 333. The electrodes 229 can thus be used to index the ablation assembly 208.

Figure 15 shows electrodes that are monopolar electrodes connected by a single power line. Power can be simultaneously delivered to the electrodes. Any number of electrodes can be positioned along the balloon 212. For example, one or more of the electrodes can be evenly or unevenly spaced about the circumference of the balloon.

Figure 16 shows electrodes 310a-310c (collectively "310") oriented at an oblique angle relatively to a longitudinal axis 312 of an ablation assembly 300. Power lines 316a-316c (collectively "316") provide energy to the respective electrodes 310. (Although not illustrated, other electrodes are located on the non-visible backside of the ablation assembly 300.) The electrodes 310 can be bipolar electrodes. By way of example, the electrode 310a can include electrode elements 318a, 319a, which can be alternatively positive and negative to transmit RF energy between the elements 318a, 319a.

The angle  $\alpha$  between the electrodes 310 and the direction of the longitudinal axis 312 can be selected based on the length of the lesions to be formed, desired circumferential gap between adjacent lesions, and the like. The illustrated angle  $\alpha$  is about 45 degrees. Other angles are also possible, if needed or desired. Between adjacent electrodes 310, there can be regions of non-treated, undamaged tissue.

As shown in Figure 16, one lesion created by an electrode or electrode pair 310a overlaps in a circumferential direction with the beginning of the next lesion created by the circumferentially adjacent electrode or electrode pair 310b to ensure that an entire circumference (or portion thereof) of a tubular body structure is treated. If an  
5 imaginary line is drawn in the longitudinal direction through one end of the lesion made by electrode 310a, the imaginary line intersects or is proximate to the near end of the adjacent lesion made by the electrode 310b. Thus, ends of adjacent lesions are axially offset along the axis 312 and overlapping in the circumferential direction.

Figure 17 shows an ablation assembly 400 that includes an expandable  
10 basket 414 and electrodes 413, 415. The basket 414 includes hollow members through which coolant flows to cool the electrodes 413, 415. A longitudinal length of the basket 414 can be selected such that the basket 414 extends across multiple cartilaginous rings. The electrodes 413, 415 can be positioned between the rings. For example, the elongate  
15 basket 414 can extend across at least three cartilaginous rings (represented by vertical dashed lines 431, 432, 433 in Figure 17). The electrodes 413 are positioned between cartilaginous rings 431, 432. The electrodes 415 are positioned between cartilaginous rings 432, 433. When the basket 414 is deployed, the distance D between adjacent rows of electrodes 413, 415 can generally correspond to the distance between the cartilaginous  
20 rings, thereby ensuring that the electrodes 413, 415 can be seated between the cartilaginous rings. The electrode 413a can have a first polarity and the electrode 413b can have an opposite polarity such that energy flows between the electrodes. The electrode pair 413a, 413b is angularly offset from the adjacent pair of electrodes 415a, 415b to form circumferentially overlapping and axially spaced apart lesions. The distance of overlap D can be sufficient to ensure that the entire circumference of the  
25 airway is treated.

Figure 18 shows fluid flowing along lumens 427, 429 and through pressure reducing elements 423, 425, respectively. As used herein, the term “pressure reducing element” refers, without limitation, to a device configured to reduce the pressure of a working fluid. The pressure reducing element can reduce the pressure of  
30 the working fluid to a pressure equal to or less than a vaporization pressure of the working fluid. The working fluid can comprise a refrigerant (*e.g.*, a cryogenic

refrigerant or a non-cryogenic refrigerant). In some embodiments, the pressure reducing elements are in the form of pressure reduction or expansion valves that cause vaporization of at least a portion of the working fluid passing therethrough. The pressure reducing element vaporizes an effective amount of the working fluid (*e.g.*, a refrigerant, cryogenic fluid, etc.) to reduce the temperature of the working fluid. In some modes, substantially all or most of the working fluid by weight passing through the elements 423, 425 is converted to a low temperature, low pressure gas. In some embodiments, the pressure reducing elements 423, 425 can be a nozzle valve, a needle valve, a Joule-Thomson throttle, a throttle element, or any other suitable valve for providing a desired pressure drop. For example, a Joule-Thomson throttle can recover work energy from the expansion of the fluid resulting in a lower downstream temperature. In some embodiments, the pressure reducing elements can be substituted with flow regulating elements (*e.g.*, a valve system), especially if the working fluid is a non-refrigerant, such as water.

With reference to Figure 18, high pressure gas  $P_1$  of Figure 18 passes through the delivery lumens 427, 429. The high pressure gas  $P_1$  passes through the elements 423, 425 and enters the channels 436, 438 where the pressure drops to  $P_2$ . The drop in pressure from  $P_1$  to  $P_2$  leads to a drop in temperature of the gas from  $T_1$  to  $T_2$ . The magnitude of the temperature change is given by:

$$T_1 - T_2 = \mu(P_1 - P_2)$$

where

$T$  is the temperature of the gas;

$P$  is the pressure of the gas;

$\mu$  is the Joule-Thomson coefficient of the gas;

Subscript 1 denotes a high pressure condition; and

Subscript 2 denotes a low pressure condition.

A second pressure drop can occur when the gas in the channels 436, 438 exits through the vents and drops to a surround pressure, as discussed in connection with Figures 19 and 20. If the ablation assembly 400 is used in the respiratory system, the surrounding pressure is atmospheric pressure. This temperature drop is:

$$T_2 - T_3 = \mu(P_2 - P_{ATM})$$

The Joule-Thomson coefficient ( $\mu$ ) is specific for each gas or gas mixtures. Standard temperature values for  $\mu$  are:

Carbon dioxide

$$5 \quad \mu_{CO_2} = 1.16 \times 10^{-5} \frac{K}{Pa}$$

Air

$$\mu_{air} = 0.23 \times 10^{-5} \frac{K}{Pa} .$$

These coefficients indicate that for a given pressure drop, CO<sub>2</sub> will cause a 5 times greater drop in temperature than a similar drop in pressure experienced by air.

10           The use of air in the lungs can be desirable. Carbon dioxide can be used if the flow rates of coolant gas are sufficiently low so as to not overwhelm the subject's ability to ventilate this additional carbon dioxide out of the lungs. The cooling effect can be enhanced if the coolant in the coolant conduit is a high pressure liquid, such as liquid  
15 elements (*e.g.*, a throttle) and undergoes an endothermal phase change from a high pressure liquid to a high pressure gas, which causes the temperature of the gas to be lower than that of the high pressure liquid. It then goes through a Joule-Thomson expansion from P<sub>1</sub> to P<sub>2</sub> which causes a further drop in temperature, before being vented out via vents 441, as discussed in connection with Figures 19 and 20.

20           Figures 19 and 20 show an ablation assembly 437 that is generally similar to the ablation assembly 400 of Figures 17 and 18, except as detailed below. The ablation assembly 437 includes an array of openings or vents 439 positioned along the elongate members. Coolant flowing through the elongate members can escape out of the openings 439 to cool adjacent tissue. Additionally, openings or vents 441 positioned at  
25 the distal end 443 can discharge coolant. As shown in Figure 20, coolant, represented by arrows, can escape out of the vents 439, 441. In this manner, coolant can cool the ablation assembly 437 and can provide direct tissue cooling. Vents 441 may optionally be configured to provide a suitable pressure drop to vaporize the coolant from Joule-Thomson expansion, as described above, thus lowering the coolant temperature.

Figure 21 shows an ablation assembly 450 that has V-shaped electrodes circumferentially spaced apart along an expandable member 453. An electrode 455 has ends 456, 457 that overlap with a tip 459 of the adjacent electrode 455. The electrodes can output energy to V-shaped target regions, which are likewise spaced apart along the airway circumference to form V-shaped lesions. Untreated tissue between the V-shaped lesions can help ensure that the lumen airway does not significantly narrow due to scar tissue or stenosis.

Figure 22 illustrates an ablation assembly 460 including an expandable element 462 carrying T-shaped electrodes. The electrode 463 has a free end 464 that overlaps with an end 465 of an adjacent electrode 467. The circumferentially aligned electrodes 461 can form a plurality of generally T-shaped lesions. In other embodiments, the electrodes can be U-shaped, S-shaped, W-shaped, L-shaped, or any other suitable shape. In addition, in any of these embodiments, the electrodes may be longitudinally displaced in a diagonal or helical pattern similar to that shown in Figure 16.

Figure 23 shows an ablation assembly 500, including a first set of elongate members 511a-511d (collectively "511") that can position electrodes 512 between cartilaginous rings 513, 515 (illustrated in dashed lines). Elongate members 521a-521d (collectively "521") carry electrodes 523a, 523b, 523c, 523d (collectively "523") positioned between the cartilaginous rings 515, 518. The electrodes 512 form lesions between the rings 513, 515. The electrodes 523 form lesions between the rings 515, 518. The elongate members 511, 521 may be flexible and resilient rods or wires biased radially outwardly to position the electrodes against the airway wall and configured to position electrodes 523 in circumferentially offset positions relative to the electrodes 512 so that different circumferential regions of an airway wall are treated with each electrode pair. One end of a lesion in one inter-collagenous space can overlap circumferentially with an adjacent lesion in an adjacent inter-collagenous space. The lesions can thus be axially spaced apart from one another but circumferentially overlapping with respect to the body lumen. The elongate members 511, 521 may be retracted into a tubular sheath 510 to collapse them into a radially contracted configuration suitable for introduction into the airway.



Figure 24 shows an ablation assembly 600 with an expandable energy emitter assembly 610. An expandable electrode assembly 623 can encircle all or a major part of an expandable member 620, illustrated as a balloon. An insulator 625 extends between the ends over a portion of the electrode assembly 623. The electrode 623 can have a zigzag configuration (illustrated), serpentine configuration, or wavy configuration to allow expansion and can extend about 90 degrees to about 360 degrees around the balloon 620. During use, the exposed electrode 623 can face a region of an airway to be treated, *e.g.*, the posterior side where the nerve trunks are often located. Alternatively, the emitter assembly 610 can include a plurality of exposed electrodes separated by insulated portions to create discrete lesions.

Optionally, a second energy emitter 618 is positioned distally of the energy emitter 610. The energy emitter 618 has an exposed electrode 621 and an insulator 623. The electrode 621 can cooperate with the electrode 623 to form circumferentially offset and axially spaced-apart complementary (*e.g.*, overlapping) lesions. For example, the electrode 623 can form a lesion having an arc length of about 180 degrees along an upper portion of an airway wall. The electrode 621 can form a lesion having an arc length of about 180 degrees along a lower portion of an airway wall. Together, the two lesions extend about the entire circumference of the airway wall. The lesions can be created simultaneously or sequentially.

Figure 25 shows an ablation assembly 700 that includes an energy emitter in the form of an electrode assembly 710 wrapped about an expandable element 712. The electrode assembly 710 includes a conduit 731 and a plurality of electrodes 715a-h (collectively "715"). The electrodes 715 can simultaneously or sequentially form lesions.

Referring to Figure 26, the electrode 715a can be a hollow tubular metallic member which, when the balloon 712 is inflated, is oriented in the general circumferential direction. The conduit 731 delivers coolant (saline or other coolant) serially through the electrodes 716.

Different coolants can be delivered through the balloon 712 and the conduit 731. Coolant can flow through a delivery lumen 761 through the conduit 731 to cool the electrodes 715. Another coolant can flow through a delivery lumen 751 and into

the balloon 712. Coolant in the balloon 712 and the conduit 731 can flow proximally via a return lumen 739. In other embodiments, coolant flows serially through the electrode assembly 710 and the balloon 712.

Separate wire pairs can be electrically coupled to each electrode 715.

5 Each electrode 715 can be operated independently. In other embodiments, the electrodes 715 are bipolar and arranged in pairs of opposite polarity. As discussed with respect to previous embodiments, the electrodes 715 can be oriented and positioned with respect to one another to form lesions within inter-collagenous spaces. U.S. Patent Application No. 12/463,304, filed May 8, 2009, and U.S. Patent Application No. 12/913,702 filed,  
10 October 27, 2010, are incorporated by reference in their entireties and disclose techniques, materials, catheters, and components that can be used with the ablation assembly 700.

Electrodes 715a-h are arranged along the helical conduit 731 such that they create lesions which are circumferentially offset from one another, albeit with some  
15 overlap, and which are axially offset from one another. An imaginary line drawn in the axial direction (parallel to axis 719) through each of electrodes 715a-h will intersect another of electrodes 715a-h to ensure that the entire circumference of the airway is treated. Advantageously, the electrodes are spaced apart along the helical conduit 731 such that the lesions they create are longitudinally separated along the airway, thus  
20 reducing the chance that stenosis will result.

Lesion shapes can be controlled by adjusting the temperature of the coolant, coolant flow rates, heat carrying capacity of coolants, thermal characteristics of the balloon (*e.g.*, the heat transfer properties of the balloon), or the amount of delivered power. Figures 27A-31B show temperature profiles and corresponding lesions formed  
25 by progressively increased cooling by a balloon. The cooling capacity of the balloon can be increased by decreasing the coolant temperature or by increasing the coolant flow rate, or both. Lesion shaping can also be achieved by holding the cooling capacity of the balloon generally constant while varying the coolant capacity of the electrode or by increasing or decreasing the power delivered to the tissue. By way of example, the  
30 ablation assembly 700 in Figure 25 can be used to form the lesions of Figures 27B, 27C, 28B, 29B, 30B, and 31B. Because the balloon 712 has a larger diameter than an

electrode channel 753, there is a relatively low flow velocity along the balloon surface as compared to the high velocity flow through the electrode 715a. This results in differential cooling. If the electrode 715a and the balloon 712 have independent flows, the coolants can be at different temperatures and/or flow velocities for differential  
5 cooling.

Figure 27A shows isotherms 80°C, 60°C, and 40°C and temperature distributions in tissue. Figure 27B shows a lesion 804 corresponding to the isotherms of Figure 27A. The coolant in a cooling channel 753 is the only coolant that absorbs a significant amount of heat. The balloon 712 does not absorb a significant amount of  
10 thermal energy and can be filled with fluid at a temperature that is generally equal to room temperature or within a range of about 20°C-30°C. In some embodiments, the balloon 712 is inflated with ambient air and can hold the electrode 715a against the tissue 825. In other embodiments, the balloon 712 is inflated with warm saline. The lesion 804 has a generally semicircular shape. The radius  $r$  and depth  $D$  can be increased or  
15 decreased by decreasing or increasing, respectively, the temperature of the coolant in the cooling channel 753. Additionally or alternatively, the radius  $r$  and depth  $D$  can be increased or decreased by decreasing or increasing, respectively, the flow rate of the coolant.

Chilled coolant can be delivered through the balloon 712 to reduce the  
20 cross-sectional width of the lesion at the tissue surface 825. Figures 28A and 28B show isotherms and a corresponding generally elliptical shaped lesion 804 when a coolant cools the electrode 715a and when a low temperature coolant flows at a low velocity through the balloon 712. The coolant in the balloon 712 absorbs a sufficient amount of thermal energy to protect tissue that contacts or is proximate to the balloon-tissue  
25 interface. In some embodiments, including the illustrated embodiment of Figure 28B, the cross-sectional width of the lesion 804 at the surface 825 is less than a cross-sectional width of the lesion 804 of Figure 27B at the surface 825. The cross-sectional width of the lesion 804 of Figure 28B increases with depth to a maximum width  $W_{Max}$  and then decreases to the deepest region 830. The maximum width  $W_{Max}$  is less than the depth  $D$   
30 of the lesion 804. Figure 28B shows the lesion 804 at the surface 825 having a width that is no more than about 150% of the electrode width.

Figures 29A and 29B show isotherms and the lesion 804 when a low temperature coolant flows at a high velocity through the balloon 712 or a very low temperature coolant flows at a low velocity through the balloon 712. The somewhat teardrop shaped lesion 804 extends from the tissue surface 825. The width of a shallow or narrowed region 834 of the lesion 804 is about equal to the cross-sectional width  $W_E$  of the electrode 715a. Thus, the lesion 804 at the surface 825 has a maximum cross-sectional width that is no more than about 150% of an electrode-tissue interface. This ensures that a minimal amount of surface tissue is damaged. The lesion 804 tapers outwardly from the shallow portion 834 to an enlarged region 835. The lesion cross-sectional width gradually increases with depth to a maximum width  $W_{Max}$ . The maximum width  $W_{Max}$  can be more than about 1 to about 5 times the cross-sectional width at the surface 825. The deepest region 830 of the lesion 804 has a partially circular shape.

Figures 30A and 30B show isotherms and a teardrop shaped lesion 804 that can be formed when a very low temperature coolant flows at a high velocity through the balloon 712. The lesion 804 extends from the tissue surface 825 and has a narrow shallow region 834 that rapidly expands outwardly to a wide deep region 852. The width of the shallow region 834 is less than a width  $W_E$  of the electrode 715a. The cross-sectional width rapidly increases with depth to a maximum width  $W_{Max}$ . Thus, most of the volume of the lesion 804 is deep in the tissue.

Figures 31A and 31B show isotherms and a corresponding circular shaped lesion 804 that can be formed when a very low temperature coolant flows at a very high velocity through the balloon 712. The lesion 804 is disposed at a depth  $D$  from the tissue surface 825. The maximum cross-section a width  $W_{Max}$  of the lesion 804 is at a depth  $D$   $W_{Max}$ . The lesion 804 is spaced apart from the electrode-tissue interface and can have different shapes depending on the flow rates and the temperatures of the coolants. Differential cooling can be used to achieve other buried lesion shapes, such as generally elliptical shapes, elongated shapes, or the like.

The  $D_{W_{Max}}$  can be selected based on the location of the target region. To damage nerve tissue, the  $D_{W_{Max}}$  can be at least about 2 mm to ensure that the lesion includes the nerve tissue and to mitigate or avoid a significant amount of damage

to smooth muscle tissue. Such embodiments are well suited for treating an airway wall because the smooth muscle tissue is typically not below a depth of 2 mm. In this manner, the cross-sectional width of the target region can be maximized at a depth deeper than the smooth muscle tissue. The majority, and in some embodiments  
5 substantially all, of the lesion will be in tissue which is not smooth muscle tissue, typically lying deeper in the airway wall than the region of smooth muscle tissue. Further, any damage to smooth muscle cells in the airway wall can be less than the amount of damage that, in the absence of damaging nerve tissue, would be required to substantially alter the responsiveness or constriction of the airway, e.g. as a result of  
10 asthma, COPD, or other pulmonary disease.

The lesion can be separated from the tissue surface by a protected region in which a significant amount of the tissue is not permanently damaged. Figures 31B and 32B show a protected region 861 having a depth  $D_p$ . Advantageously, because a significant amount of tissue in the protected region 861 is not permanently damaged,  
15 tissue functioning can be preserved. The depth  $D_p$  can be at least about 1 mm to about 2 mm to ablate nerve tissue.

Figure 32 shows a helical ablation assembly 900 that includes a curved (illustrated as helical-shaped) main body 910 (shown tapered to match an airway taper) and electrodes 912a, 912b, 912c (collectively "912"). Optionally, one or more pressure  
20 reducing elements can be positioned within the body 910 to act as Joule-Thomson throttle to reduce the temperature of the coolant.

The electrodes 912 can be generally similar to each other and, accordingly, the description of one electrode applies equally to the others, unless indicated otherwise. The electrode 912a includes a plurality of vents 916, 918. Coolant,  
25 represented by arrows, can flow out of the vents 916, 918. The electrode 912a can be coupled to an exterior surface of the main body 910. This allows the electrodes 912 to protrude outwardly a sufficient distance to physically contact with tissue. Electrodes 912 are arranged to create lesions which are circumferentially offset from one another, but which have some circumferential overlaps at their edges, i.e., an imaginary line drawn  
30 longitudinally down the airway through the end of one lesion will intersect the end of the next lesion. Because electrodes 912 are spaced apart along the helical body 910, the

lesions they create are also spaced apart axially in the airway, thus reducing the possibility of stenosis.

The main body 910 may comprise a flexible and electrically conductible material, such as Nitinol, that can be shaped into a helical or corkscrew shape when  
5 activated. A warm fluid can be delivered through the main body 910, causing the body 910 to move from a delivery configuration (*e.g.*, a straight configuration) to a deployed configuration (*e.g.*, a corkscrew configuration or a helical configuration). In other embodiments, the main body 910 can be biased towards the deployed configuration and can be delivered out of a sleeve or working lumen to assume the deployed configuration.  
10 The ablation assembly 900 can be pulled proximally into the sleeve or working lumen to return the ablation assembly 900 to a delivery configuration. In other embodiments, tensioners, pull wires, pull rods, or the like can be used to cause the main body 910 to assume different configurations.

Optionally, a balloon can be positioned through an interior region 920. A  
15 generally conically-shaped balloon, cylindrical balloon, hot dog shaped balloon, or other suitably shaped balloon may be insertable into the interior region 920.

Figure 33 shows a helical ablation assembly 952 made of a tubular conductive inner member having with series of spaced-apart exposed sections forming electrodes 960a, 960b, 960c (collectively "960") with an insulative cover over the  
20 intervening sections to create insulated regions 962a, 962b, 962c. A coolant can be circulated through the ablation assembly 520 to cool electrodes 960. To provide additional tissue cooling, the coolant can optionally be delivered out of vents (not shown) in the inner tubular member and/or the insulative cover.

Figure 34 shows an ablation assembly 1000 that includes an array of  
25 spaced apart bipolar electrodes 1010a-f (collectively "1010"). The electrodes are arranged in pairs of opposite polarity, such that lesions are created diagonally between each bipolar pair. The electrodes 1010 can form oblique lesions that traverse cartilaginous rings. As shown in Figure 35, the ablation assembly 1000 is positioned within an airway 1012. The electrodes 1010 are positioned between the rings.  
30 Electrodes 1010a-c can create a lesion 1030 of Figure 36. An end 1032 of the lesion 1030 is proximate to a ring 1034. An opposing end 1036 is adjacent to a ring 1038. The

ends 1032, 1036 are displaced from one another axially along the airway 1012. As shown in Figure 36, the axial displacement of the ends 1032, 1036 is significantly greater than the circumferential distance between the ends 1032, 1036. In certain procedures, the distance between the ends 1032, 1036 is at least one millimeter, 5 millimeters, 10 millimeters. In some embodiments, the axial distance between the ends 1032, 1036 is greater than the distance between adjacent cartilaginous rings. This ensures that the lesions traverse the rings.

A central section of the lesion 1030 of Figure 36 traverses a ring 1040 between the rings 1034, 1038. Electrodes 1010d, 1010e, 1010f on the back side of the ablation assembly 1000 form a lesion 1041. The illustrated lesions 1041, 1030 are on opposite sides and at different axial locations along the airway.

The electrodes 1010 can protrude outwardly a sufficient distance to interact with the airway tissue to keep the electrodes 1010 located between cartilaginous rings. When operating in bipolar mode, lesions are formed and traverse the rings. After forming the lesions, the catheter can be pulled proximally or pushed distally and used to form axially offset lesions. Additionally or alternatively, the catheter can be rotated to form oblique lesions at different angular positions along the airway 1012. The lesions of Figure 36 are illustrated as continuous lesions. In other embodiments, lesions can comprise a plurality of discrete spaced-apart lesions. For example, the lesion 1030 can comprise an array of spaced-apart lesions.

Figures 37 and 38 show circumferentially offset and axially spaced-apart electrodes 1050a, 1050b cooled by an internal jet. A coolant flows through a delivery lumen 1052 and exits a port 1054. The jet of coolant flows along an open cooling channel 1056 to cool the electrode 1050a. The coolant exits a chamber 1060 via outlet ports 1062a, 1062b. The coolant flows along a return lumen 1072. The electrodes 1050a, 1050b can be operated either in a monopolar mode or in bipolar mode while being cooled.

Figures 39A-40B show an ablation assembly 1080 that includes an energy emitter in the form of an electrode assembly 1082. The electrode assembly 1082 includes an array of electrodes 1084a-f (collectively "1084") that can form a lesion 1083 (Figures 39B and 40B). A wide range of different types of serpentine, curved, zigzag, z-

shaped, or other various configurations. The illustrated lesion 1083 has a generally helical shape and traverses multiple cartilaginous rings. The ablation assembly 1080 can have any number of these types of electrode assemblies 1082. For example, a pair of helical ablation assemblies 1082 can be positioned on the outside of the ablation  
5 assembly 1080.

The illustrated lesion 1083 is continuous and has ends 1085, 1087 that are spaced axially apart along a long axis 1089 of the airway. The ends 1085, 1087 are also angularly offset from one another. As shown in Figures 39B and 40B, the distance between the ends 1085, 1087 along the axis 1089 is greater than the distance between  
10 adjacent rings. As such, the lesion 1083 traverses multiple rings.

The electrodes 1084 can be close together to form the generally contiguous lesion 1083. In other embodiments, the distance between the electrodes 1084 can be increased to provide a plurality of spaced-apart lesions. The spaced-apart lesions can be arranged to have a shape similar to the lesion 1083 but other shapes and lesion  
15 patterns are possible.

Figure 41 shows an ablation assembly 1100 with an electrode assembly 1110 that wraps around a balloon 1111. The electrode assembly 1110 comprises a tube 1113 suitable for containing a coolant and has a distal end 1115 in communication with the interior of the balloon 1111. Electrodes are mounted, adhered, painted, or otherwise  
20 coupled to the exterior of the tube 1113. In this way, coolant may be delivered through the catheter to the interior of the balloon 1111 to inflate the balloon 1111, from which the coolant flows through the tube 1113 to cool the electrodes. Alternatively, the coolant can cool the electrodes and subsequently the balloon 1111. The electrode assembly 1110 and balloon 1111 can provide differential cooling to form shaped lesions.

Figures 42-44 show an ablation assembly 1200 movable from a delivery configuration (Figure 42) to a deployed configuration (Figures 43 and 44). In the delivery configuration, a distal portion 1211 of ablation assembly 1200 is linearized with the proximal portion of the catheter shaft 1213 so as to be generally aligned with a longitudinal axis of the airway or other body lumen into which it is being inserted. In the  
25 30 deployed configuration, the distal portion 1211 of the ablation assembly 1200 is deflected or deformed such that it forms a loop 1215 which lies in a plane which is



transverse to the longitudinal axis of the proximal extremity of the catheter shaft 1213. In this way, the loop 1215 may extend around the inner wall of the airway to position electrodes 1220 at a series of circumferentially spaced-apart locations thereon.

In the deployed configuration, the loop may be helical or may lie in a plane disposed at an oblique angle relative to the longitudinal axis of the catheter shaft 1213 such that electrodes 1220 are positioned at axially separated locations along the airway wall. Loop 1215 may be deployed using a variety of well known mechanisms. For example, a pull wire may extend slidably through a lumen in the catheter shaft and be fixed at a point near the distal end such that tension on the pull wire deploys the loop 1215 in the desired configuration. Alternatively, the distal portion of the catheter may be preformed in the deployed configuration and may be resilient such that the distal portion may be constrained within a sheath during delivery, then released by retracting the sheath such that the distal portion resumes the deployed configuration.

Vents 1210a-1210c (collectively "1210") provide direct coolant cooling of tissue. Electrodes 1220a-c (collectively "1220") are operated independently to form discrete lesions or operated together to form one aggregate electrode for forming a continuous lesion. The electrodes 1220 can be positioned between two cartilage rings in the proximal main stem bronchii to treat about one-third of the circumference of the airway (*e.g.*, anterior medial or anterior lateral region of the airway). The electrodes 1220 are then repositioned distally between two distal cartilaginous rings to treat the other third anterior lateral or anterior medial portion of the airway wall. The electrodes 1220 are moved again to treat the posterior third of the airway, such as membrane portion. Coolant can be delivered through the vents 1210 to cool the tissue. The ablation assembly 1200 can be used to sequentially ablate different sections of vessels and can be moved distally and proximally to provide sufficient spacing between lesions to mitigate scar tissue or stenosis, if any.

The delivery devices disclosed herein can treat the digestive system, nervous system, vascular system, or other systems. For example, the elongate assemblies, intra-luminal catheters, and delivery devices disclosed herein can be delivered through blood vessels to treat the vascular system. The treatment systems and its components disclosed herein can be used as an adjunct during another medical

procedure, such as minimally invasive procedures, open procedures, semi-open procedures, or other surgical procedures (*e.g.*, lung volume reduction surgery) that provide access to a desired target site. Various surgical procedures on the chest may provide access to lung tissue. Access techniques and procedures used to provide access to a target region can be performed by a surgeon and/or a robotic system. Those skilled in the art recognize that there are many different ways that a target region can be accessed.

Guidewires, delivery sheaths, optical instruments, introducers, trocars, biopsy needles, or other suitable medical equipment can be used to steer the delivery apparatuses. If the target treatment site is at a distant location in the patient (*e.g.*, a treatment site near the lung root 24 of Figure 1), a wide range of instruments and techniques can be used to access the site. The flexible elongated assemblies can be easily positioned within the subject using, for example, steerable delivery devices, such as endoscopes and bronchoscopes, as discussed above.

Semi-rigid or rigid elongated assemblies can be delivered using trocars, access ports, rigid delivery sheaths using semi-open procedures, open procedures, or other delivery tools/procedures that provide a somewhat straight delivery path. Advantageously, the semi-rigid or rigid elongated assemblies can be sufficiently rigid to access and treat remote tissue, such as the vagus nerve, nerve branches, nerve fibers, and/or nerve trunks along the airways, without delivering the elongated assemblies through the airways. The embodiments and techniques disclosed herein can be used with other procedures, such as bronchial thermoplasty.

Unless the context requires otherwise, throughout the specification and claims which follow, the word “comprise” and variations thereof, such as “comprises” and “comprising” are to be construed in an open, inclusive sense, that is, as “including but not limited to.”

The various embodiments described above can be combined to provide further embodiments. These and other changes can be made to the embodiments in light of the above-detailed description. The embodiments, features, systems, devices, materials, methods and techniques described herein may, in some embodiments, be similar to any one or more of the embodiments, features, systems, devices, materials,

methods and techniques described in of Application No. 12/463,304 filed on May 8, 2009; U.S. Application No. 12/913,702 filed on October 27, 2010; U.S. Provisional Patent Application No. 61/255,367 filed October 27, 2009; and U.S. Provisional Patent Application No. 61/260,348 filed November 11, 2009. Each of these applications is  
5 incorporated herein by reference in its entirety. In addition, the embodiments, features, systems, devices, materials, methods and techniques described herein may, in certain embodiments, be applied to or used in connection with any one or more of the embodiments, features, systems, devices, materials, methods and techniques disclosed in the above-mentioned U.S. Patent Application Serial No. 12/463,304 and U.S.  
10 Application No. 12/913,702 filed on October 27, 2010. For example, the apparatuses of disclosed in U.S. Patent Application Serial No. 12/463,304 and U.S. Application No. 12/913,702 filed on October 27, 2010 may incorporate the electrodes or other features disclosed herein.

In addition, the embodiments, features, systems, delivery devices,  
15 materials, methods and techniques described herein may, in certain embodiments, be applied to or used in connection with any one or more of the embodiments, features, systems, devices, materials, methods and techniques disclosed in the above-mentioned of Application No. 12/463,304 filed on May 8, 2009; U.S. Application No. 12/913,702 filed on October 27, 2010; U.S. Provisional Patent Application No. 61/255,367 filed October  
20 27, 2009; and U.S. Provisional Patent Application No. 61/260,348 filed November 11, 2009.

In general, in the following claims, the terms used should not be construed to limit the claims to the specific embodiments disclosed in the specification and the claims, but should be construed to include all possible embodiments along with  
25 the full scope of equivalents to which such claims are entitled. Accordingly, the claims are not limited by the disclosure.

The various embodiments described above can be combined to provide further embodiments. All of the U.S. patents, U.S. patent application publications, U.S. patent applications, foreign patents, foreign patent applications and non-patent  
30 publications referred to in this specification and/or listed in the Application Data Sheet are incorporated herein by reference, in their entirety. Aspects of the embodiments can

be modified, if necessary to employ concepts of the various patents, applications and publications to provide yet further embodiments.

These and other changes can be made to the embodiments in light of the above-detailed description. In general, in the following claims, the terms used should  
5 not be construed to limit the claims to the specific embodiments disclosed in the specification and the claims, but should be construed to include all possible embodiments along with the full scope of equivalents to which such claims are entitled. Accordingly, the claims are not limited by the disclosure.

## CLAIMS

What is claimed is:

1. An energy delivery device, comprising:  
a catheter shaft; and  
an ablation assembly coupled to the catheter shaft and including  
a cooling element movable from a collapsed state to an expanded state, and  
an intercartilaginous energy emitter including a plurality of electrodes circumferentially offset from one another about a longitudinal axis of the ablation assembly, the electrodes being configured to delivery energy to a plurality of target regions of an airway that are spaced apart from one another with respect to a longitudinal axis of the ablation assembly, and wherein the energy emitter and the cooling element are configured to cooperate to form intercartilaginous lesions which are spaced apart from surface tissue of the airway and positioned between cartilaginous rings of the airway.
2. The energy delivery device of claim 1, wherein the energy emitter is configured to produce lesions spaced apart from one another along a long axis of the airway.
3. The energy delivery device of claim 1, wherein a projection of the target regions in a direction along a long axis of the airway onto an imaginary plane orthogonal to the long axis of the airway defines a substantially closed ring.
4. The energy delivery device of claim 1, wherein at least a portion of the ablation assembly has a spiral shape or a helical shape.
5. The energy delivery device of claim 1, wherein at least a portion of two target regions overlap when viewed down a lumen of the airway.

6. The energy delivery device of claim 1, wherein the catheter shaft has a delivery lumen for delivering coolant to the cooling element and to the energy emitter.

7. The energy delivery device of claim 1, wherein a cooling channel of the energy emitter is separate from a chamber of the cooling element to enable independent delivery of a first coolant from the catheter shaft to the channel of the energy emitter and a second coolant to the chamber of the cooling element.

8. The energy delivery device of claim 1, wherein the energy emitter includes an electrode with a coolant channel for a flow of coolant therethrough.

9. The energy delivery device of claim 1, wherein the cooling element includes an expandable basket having hollow elongate members with coolant channels.

10. The energy delivery device of claim 1, wherein at least one of the electrodes is configured to output a sufficient amount of radiofrequency energy to ablate a portion of a nerve trunk extending along a bronchial tree to attenuate nervous system signals transmitted to a portion of the bronchial tree while the cooling element is in the expanded state, and wherein the cooling element absorbs a sufficient amount of thermal energy from a wall of the airway to limit or prevent damage to the tissue between the energy emitter and the nerve tissue.

11. An intraluminal delivery device, comprising:  
an ablation assembly including an expandable device and a plurality of electrodes, the electrodes being spaced apart about a circumference of the expandable member and capable of outputting energy to discrete target regions to form lesions at the target regions, and wherein at least a portion of a first lesion is axially spaced apart from and circumferentially adjacent to or overlapping a second lesion.

12. The intraluminal delivery device of claim 11, wherein the electrodes are configured to form one set of the lesions that is axially separated from a second set of the lesions along a longitudinal axis of the ablation assembly.
13. The intraluminal delivery device of claim 11, wherein the electrodes are V-shaped or T-shaped.
14. The intraluminal delivery device of claim 11, wherein the expandable device includes a plurality of tines with free ends carrying the electrodes.
15. The intraluminal delivery device of claim 11, wherein at least one electrode has a cooling channel through which fluid is capable of flowing to cool the electrode, and wherein the expandable device comprises a balloon or an expandable basket.
16. The intraluminal delivery device of claim 11, wherein the expandable device is movable from a delivery configuration to a helical deployed configuration, and the electrodes are positioned to deliver energy to the target regions when the expandable device is in the deployed configuration.
17. The intraluminal delivery device of claim 11, wherein the electrodes are positionable such that a projection of the target regions in a direction along a longitudinal axis of the ablation assembly onto an imaginary plane orthogonal to the longitudinal axis defines a substantially closed ring.
18. The intraluminal delivery device of claim 11, wherein the electrodes are positionable such that a projection of the target regions in a direction along a longitudinal axis of the ablation assembly onto an imaginary plane orthogonal to the longitudinal axis defines an arcuate treatment region.

19. The intraluminal delivery device of claim 11, wherein the electrodes are configured to output energy to two adjacent target regions such that a distance of circumferential overlap between the two adjacent target regions is at least 0.5 mm.

20. A method of treating a subject, comprising:  
positioning an ablation assembly with respect to an airway; and  
outputting energy from the ablation assembly to axially spaced apart target regions of the airway, and wherein profiles of the target regions overlap when viewed in a direction along a long axis of the airway.

21. The method of claim 20, further comprising forming a first lesion at a first one of the target regions and a second lesion at a second one of the target regions, and wherein a portion of the first lesion overlaps a portion of the second lesion when viewed in the direction along the long axis of the airway.

22. The method of claim 20, wherein the ablation assembly is configured to form lesions at the target regions, each lesion at least partially surrounds a lumen of the airway.

23. The method of claim 20, further comprising heating tissue at a depth greater than about 2 mm to cause cell death while maintaining tissues at a depth less than 2 mm in the airway wall at a temperature below that at which cell death occurs.

24. The method of claim 20, further comprising delivering coolant through the ablation assembly to cool tissues of the airway at a depth less than 2 mm.

25. A method of treating a subject, comprising:  
moving an energy emitter of a delivery device along an airway;  
positioning at least one electrode of the energy emitter between cartilaginous rings of the airway; and



delivering energy from the electrode to target regions at axially separated locations along a long axis of the airway to form inter-cartilaginous lesions.

26. The method of claim 25, further comprising cooling the wall of the airway to protect interior tissue of the airway.

27. The method of claim 25, further comprising forming at least two lesions that circumferentially overlap one another.

28. The method of claim 25, wherein one of the lesions lies in a first imaginary plane orthogonal to a long axis of the airway and the another lesion lies in a second imaginary plane orthogonal to the long axis of the airway, wherein the first imaginary plane and the second imaginary plane are axially spaced apart along the long axis of the airway.

29. The method of claim 25, further comprising cooling a wall of the airway while delivering the energy to limit or prevent cell death in tissue located between a nerve trunk and the energy emitter.

30. The method of claim 25, further comprising heating tissue at a depth of at least about 2 mm to cause cell death while maintaining tissues at a depth less than 2 mm in the airway wall at a temperature below that at which cell death occurs.

31. The method of claim 25, further comprising delivering coolant through the electrode while the electrode outputs the energy.

32. A method of treating tissue, comprising:  
positioning an ablation assembly in a lumen of an airway; and  
delivering energy to tissue of the airway using at least one electrode of the ablation assembly positioned near an inner surface of the airway, wherein the energy damages target regions axially separated along the airway such that portions of the target

regions defining maximum cross-sectional widths of the target regions are separated from the inner surface of the airway.

33. The method of claim 32, further comprising positioning a plurality of the electrodes between cartilaginous rings while delivering the energy.

34. The method of claim 32, further comprising delivering the energy to form at least one helical-shaped lesion or spiral-shaped lesion.

35. The method of claim 32, wherein the maximum cross-sectional width of at least one target region is at a depth at least 2 mm from the inner surface of the airway contacting the ablation assembly.

36. The method of claim 32, further comprising damaging tissue at one of the target regions such that the cross-sectional width of the damaged tissue is maximized at a depth deeper than a region of smooth muscle tissue in the tissue.

37. The method of claim 32, wherein delivering the energy comprises damaging at least one target region such that a majority of that target region is outside a region of smooth muscle tissue of the tissue.

38. The method of claim 37, wherein most of a volume of the damaged tissue is outside of a region of smooth muscle tissue.

39. A delivery device, comprising:  
a catheter shaft; and  
an ablation assembly coupled to the catheter shaft, the ablation assembly including a deployable element movable from a delivery state to a deployed state, and an energy emitter capable of emitting energy to produce lesions that have ends axially displaced from one another along an axial length of a body structure when the deployment element is in the deployed state.

40. The delivery device of claim 39, wherein the energy emitter comprises a plurality of electrodes configured to form a spiral-shaped lesion, a helical-shaped lesion, or a z-shaped lesion.

41. The delivery device of claim 39, wherein the electrode emitter wraps around the deployable element.

42. The delivery device of claim 39, wherein one end of the energy emitter extends circumferentially about the deployable element, an opposing end of the energy emitter extends circumferentially about the deployable element, and a central region of the energy emitter extends obliquely about the deployable element with respect to a longitudinal axis of the ablation assembly.

43. The delivery device of claim 39, wherein a plurality of electrodes of the energy emitter extend obliquely along the ablation assembly with respect to a longitudinal axis of the ablation assembly.

44. The delivery device of claim 39, wherein the energy emitter includes a plurality of electrodes spaced apart so as to form a lesion having a spiral shape, a helical shape, or a Z-shape.

45. The delivery device of claim 44, wherein the lesion is a continuous lesion.

46. The delivery device of claim 45, wherein the lesion is a discontinuous lesion.

47. A method for treating a subject, comprising:  
positioning an ablation assembly within an airway; and  
delivering energy from the ablation assembly to form at least one lesion

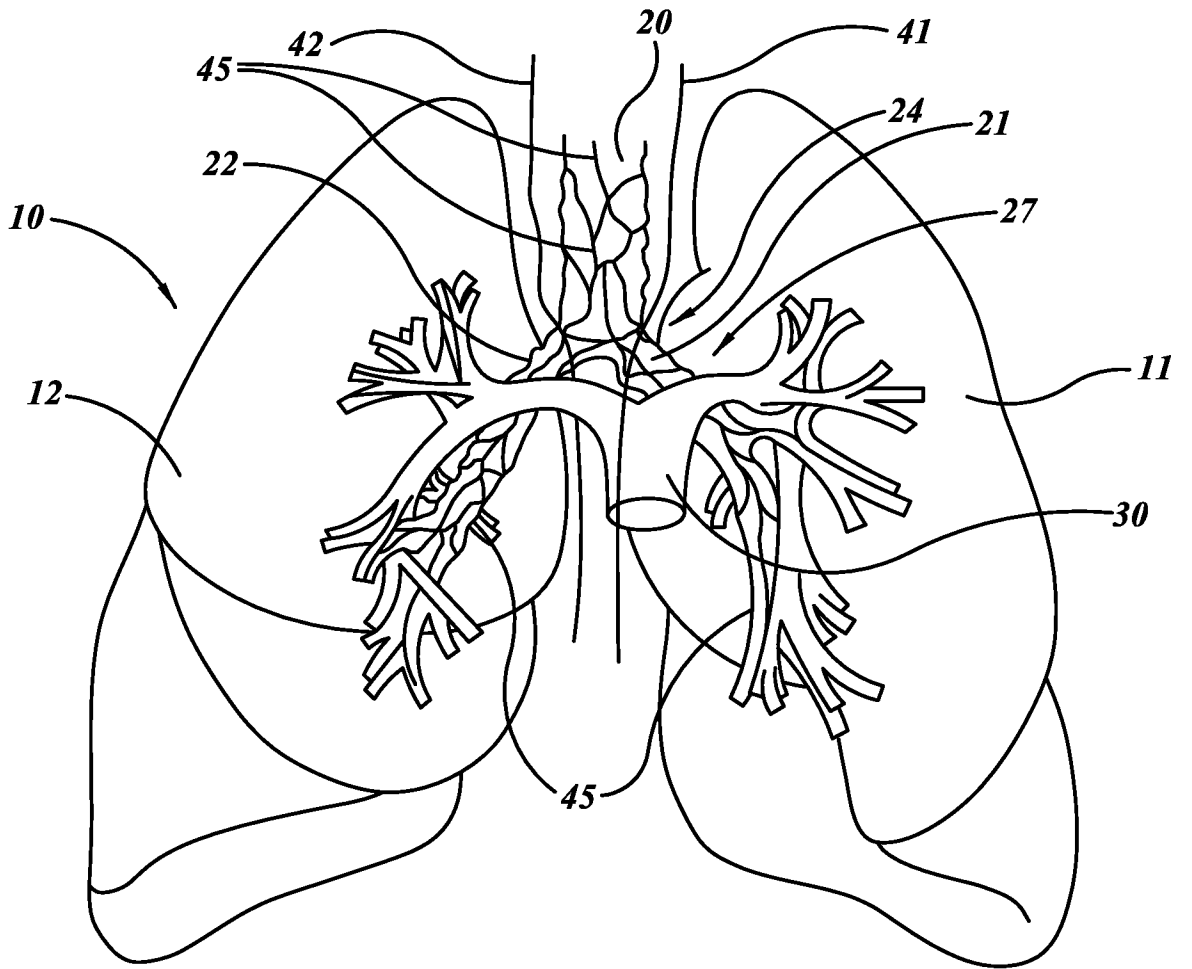
that has opposing ends axially offset with respect to one another in a direction of a long axis of the airway.

48. The method of claim 47, wherein the opposing ends are separated by a distance of at least 5 mm as measured along a long axis of the ablation assembly.

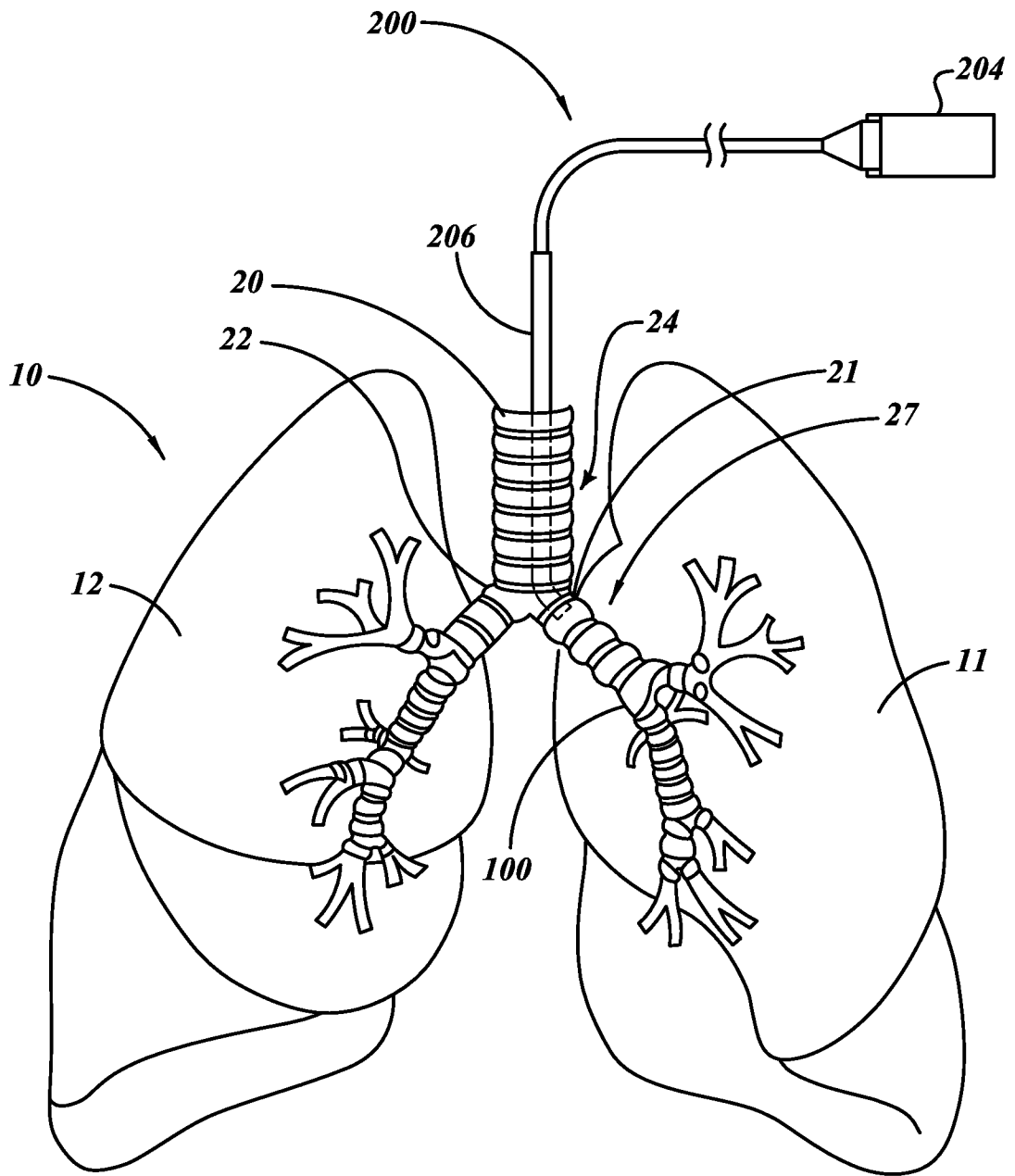
49. The method of claim 47, further comprising delivering energy to form a continuous lesion that has a spiral shape or a helical shape.

50. The method of claim 47, further comprising forming a discontinuous lesion having a spiral shape or a helical shape.

51. The method of claim 47, wherein the at least one lesion comprises a plurality of spaced apart lesions positioned about the airway.

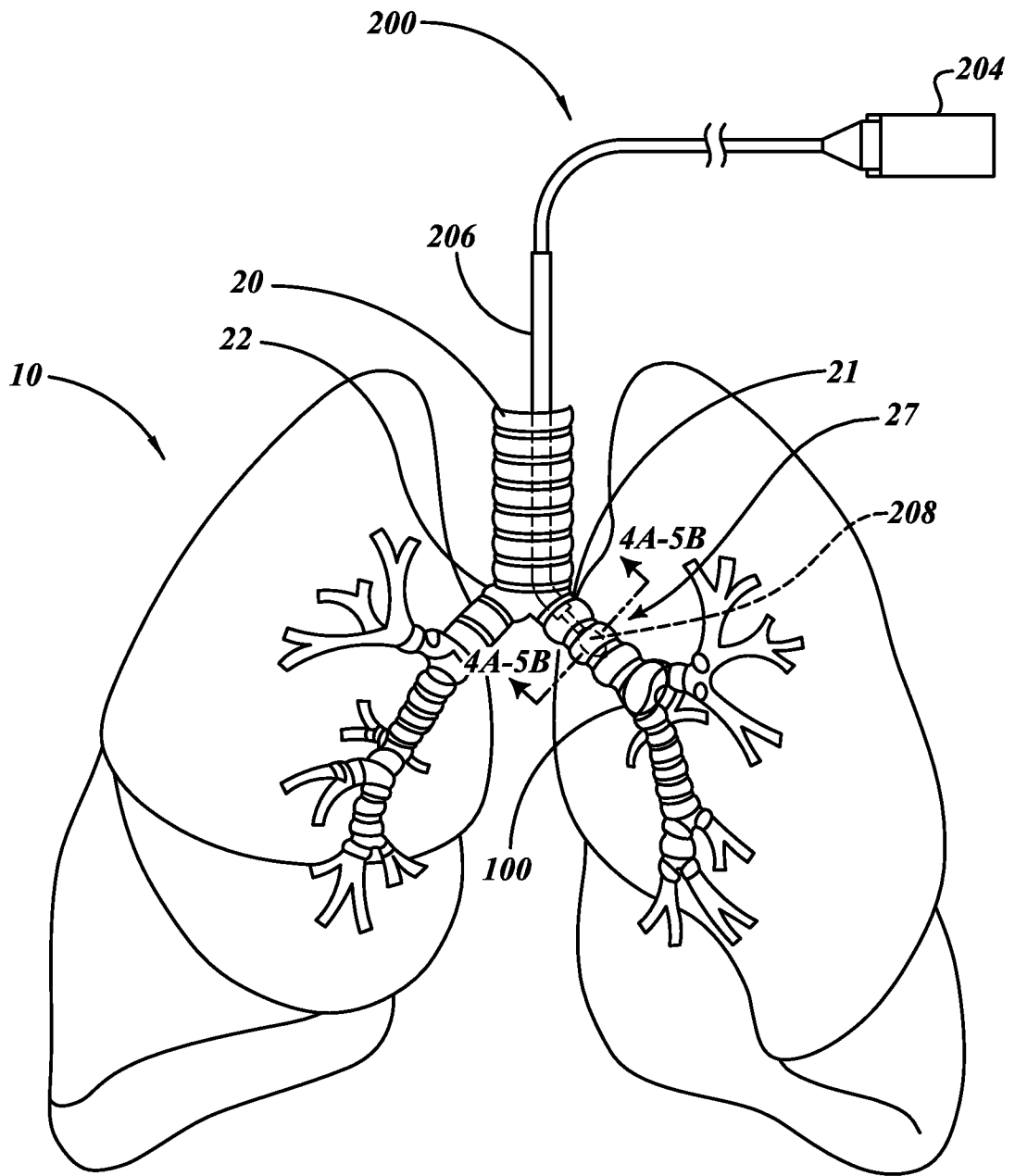


**FIG. 1**

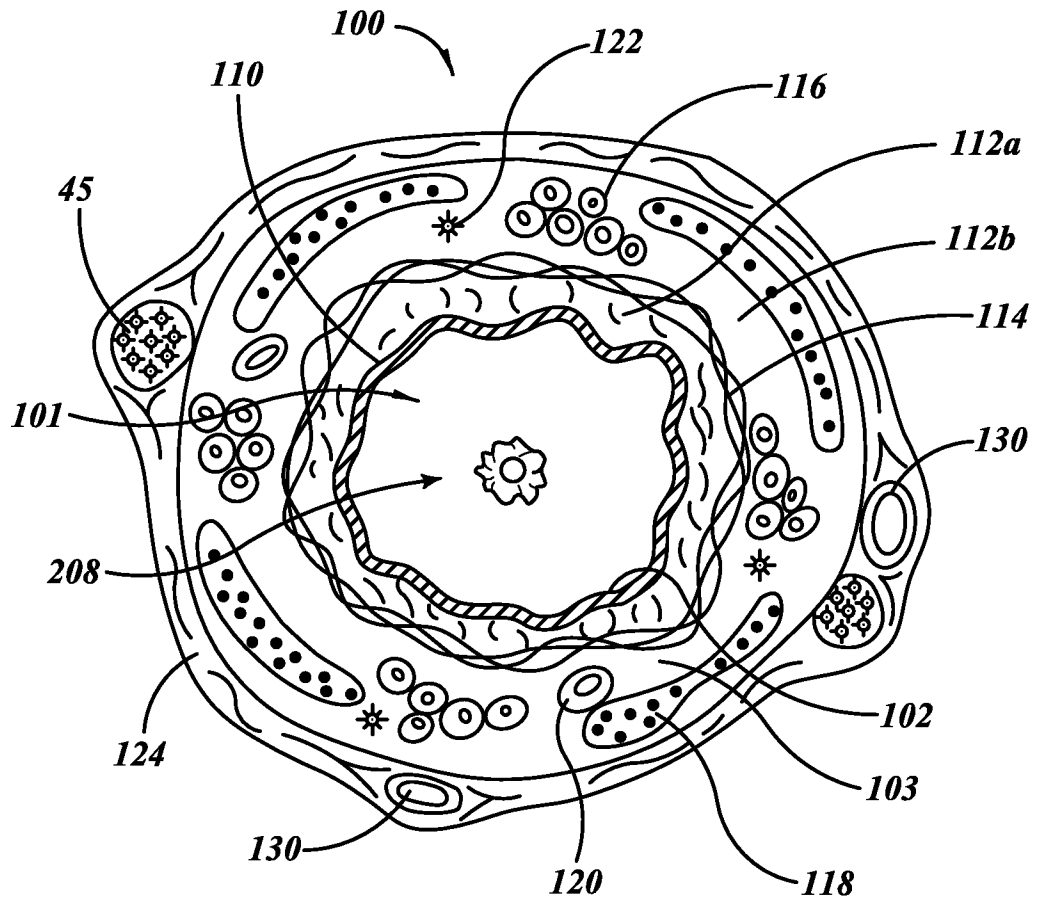


**FIG. 2**

3/29

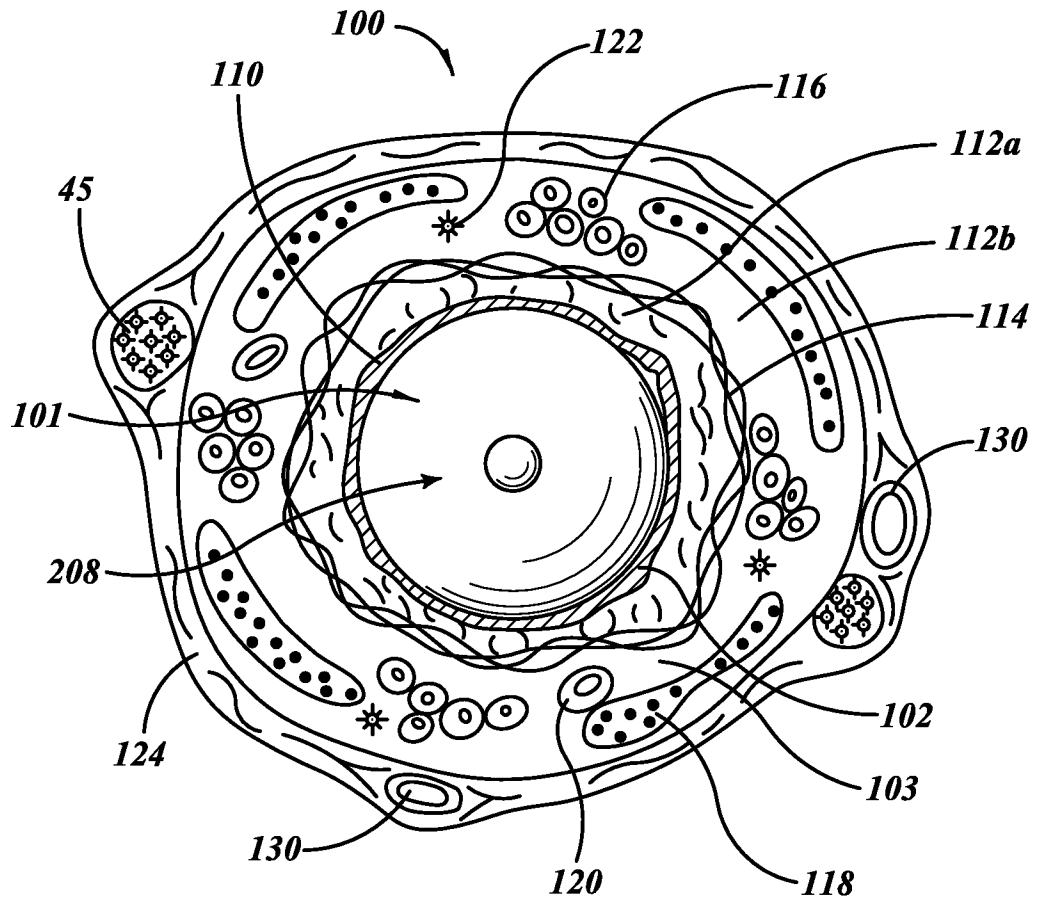


**FIG. 3**

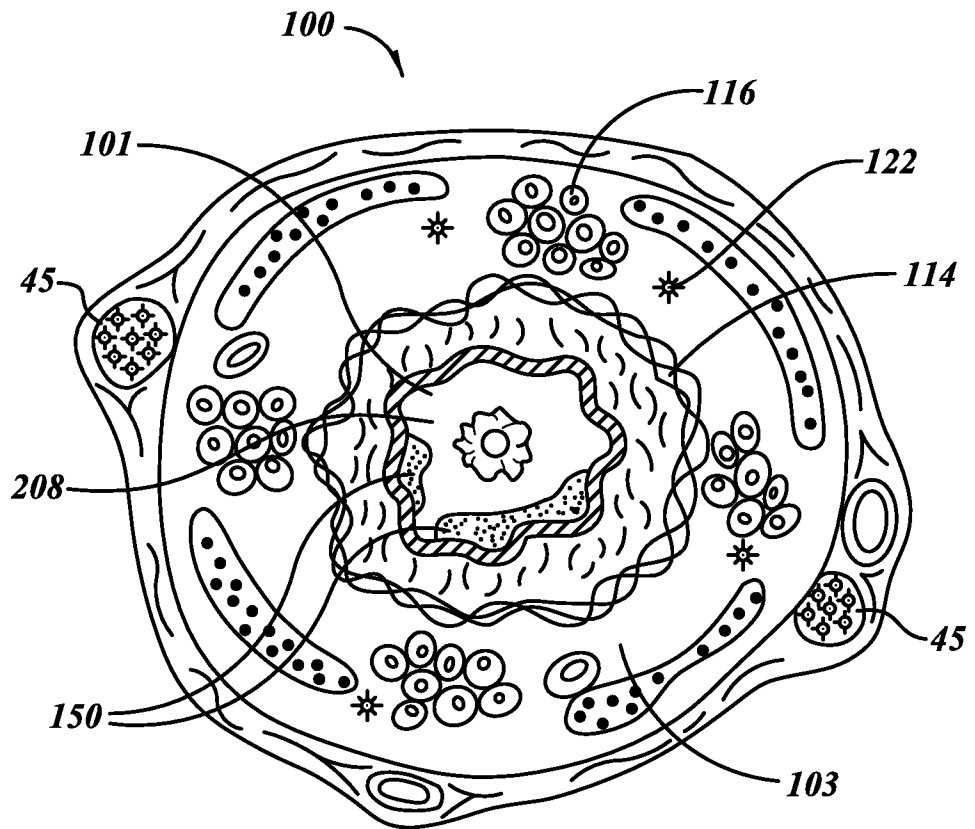


**FIG. 4A**



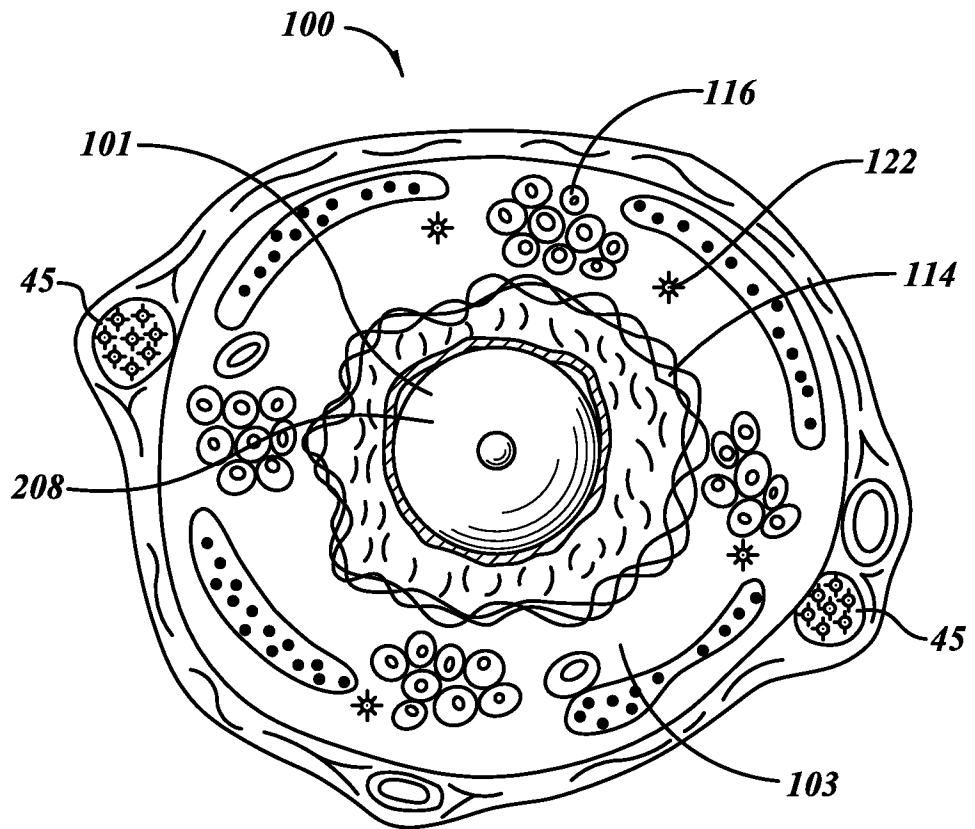


**FIG. 4B**



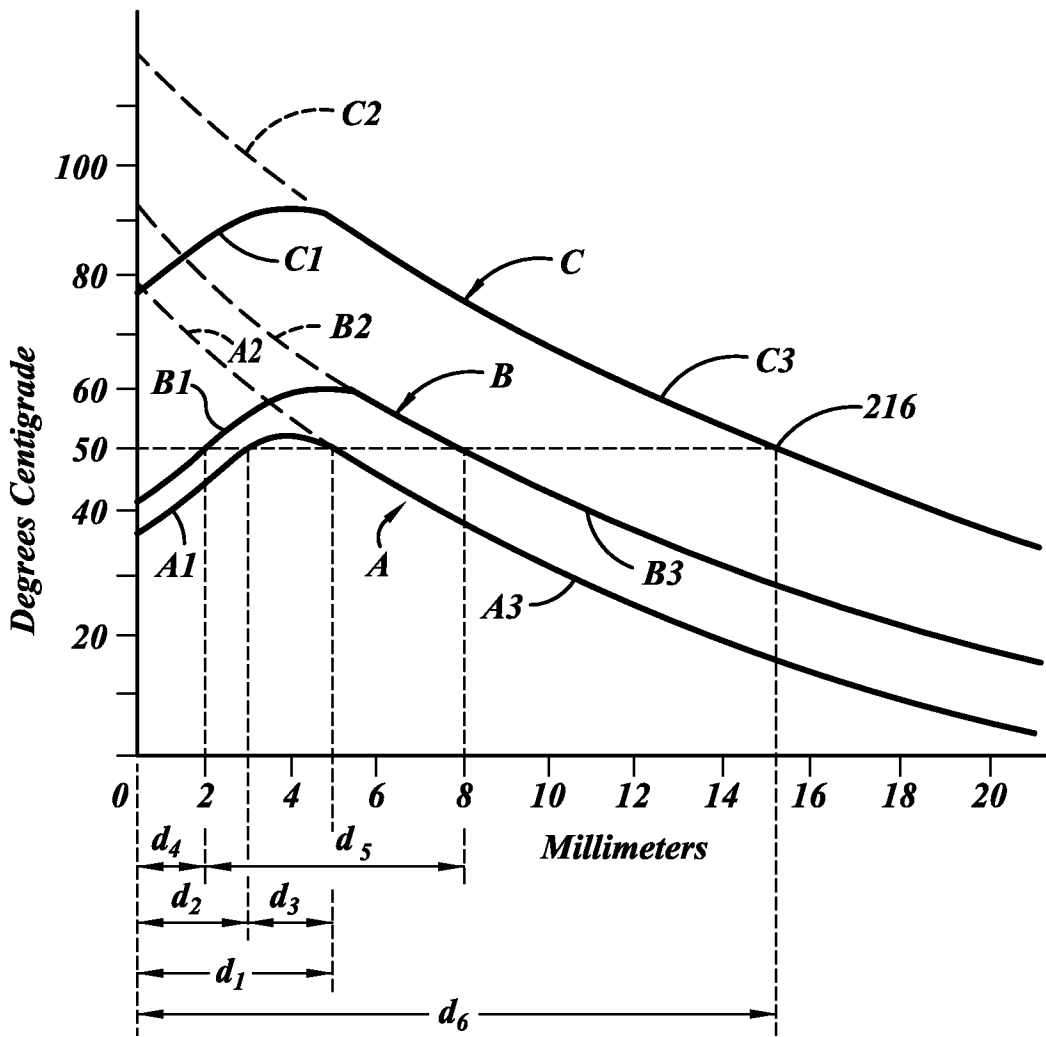
**FIG. 5A**

7/29

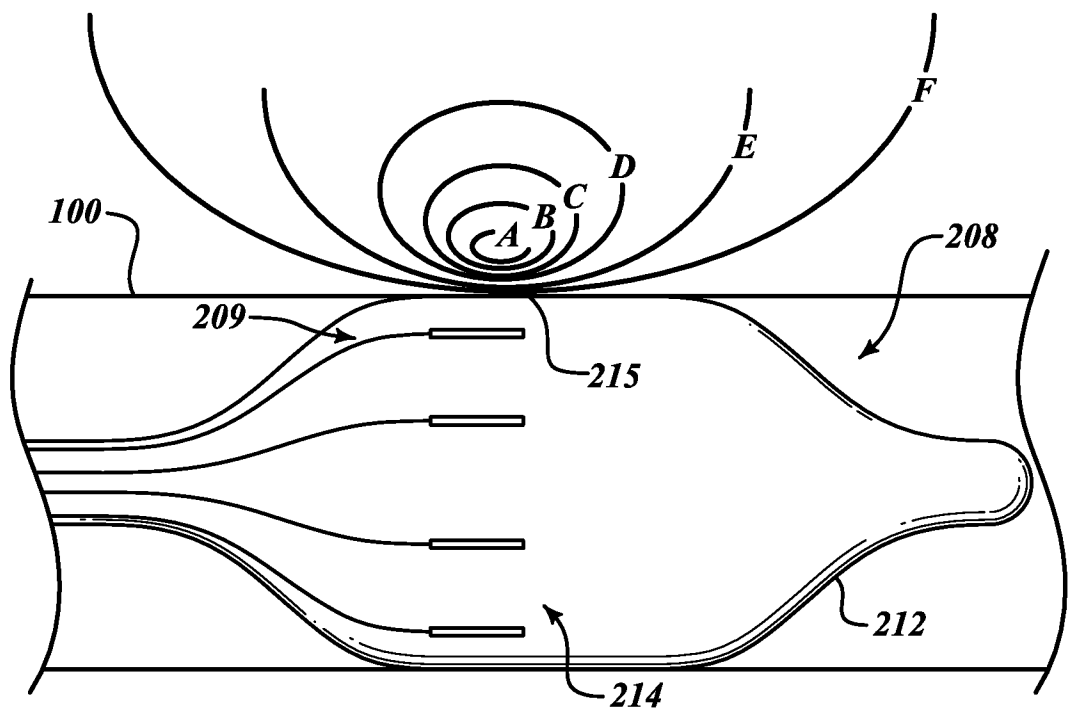


**FIG. 5B**

8/29

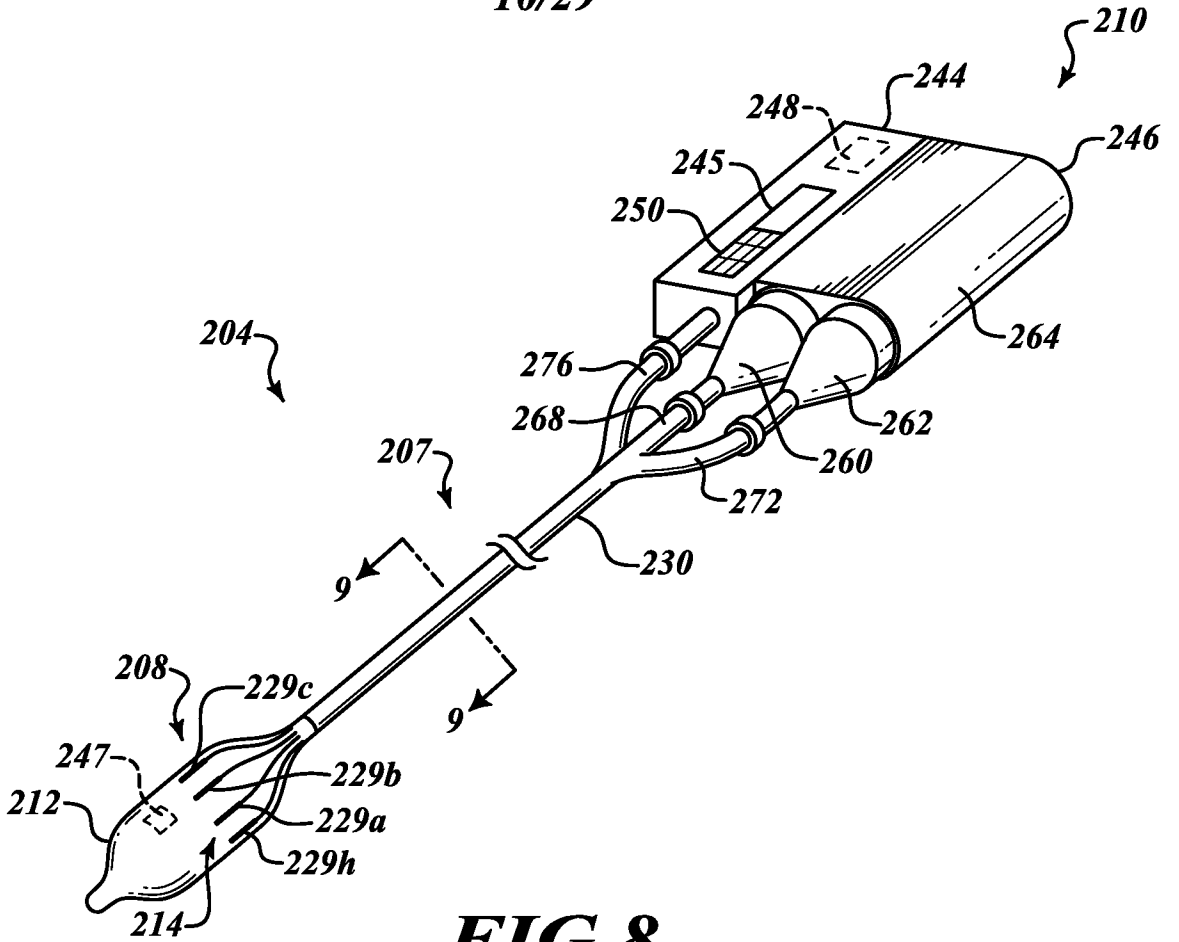


**FIG. 6**

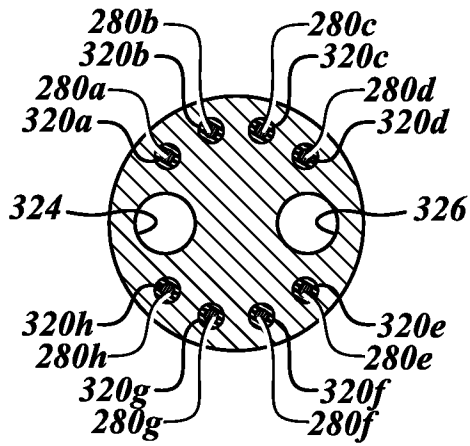


**FIG. 7**

10/29

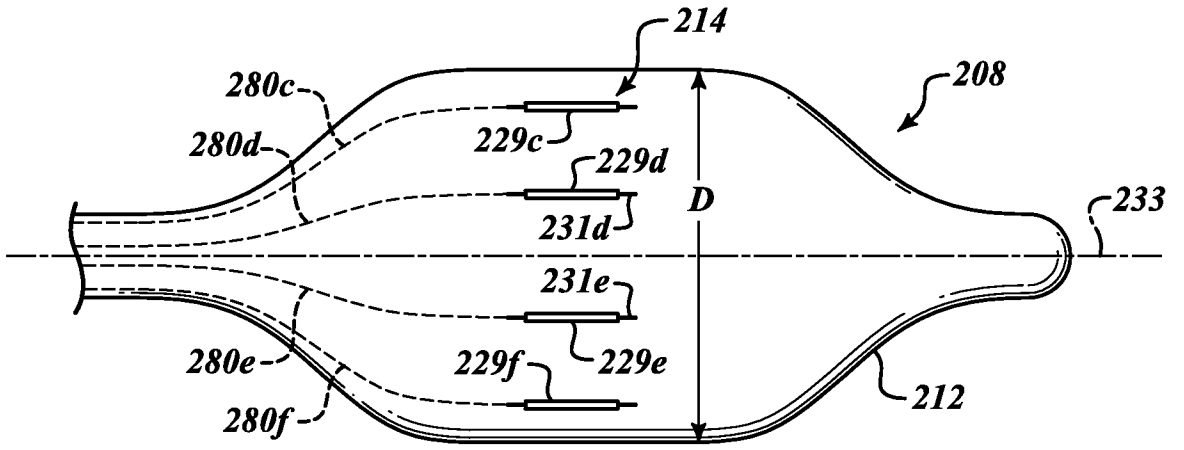


**FIG. 8**

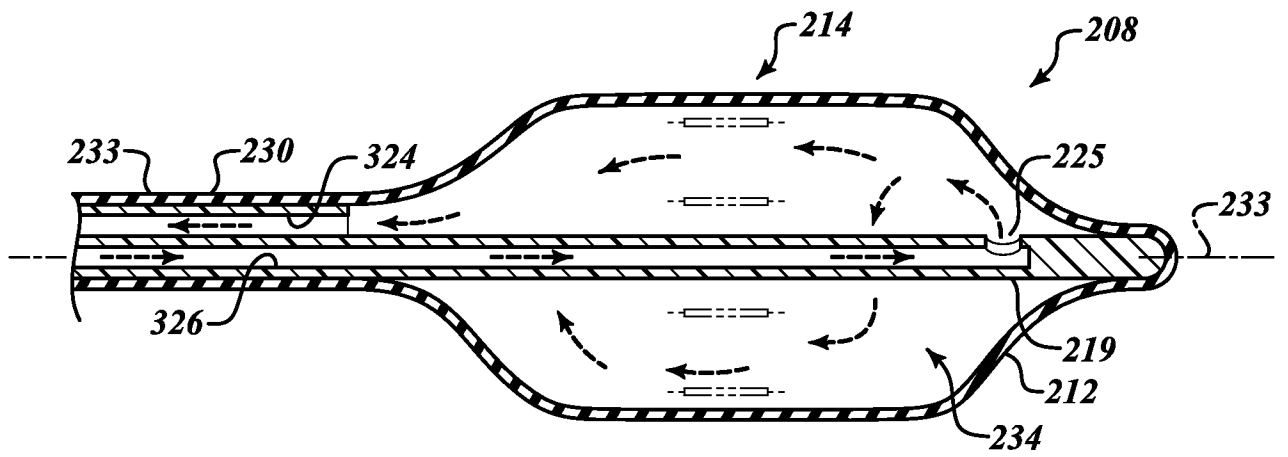


**FIG. 9**

11/29

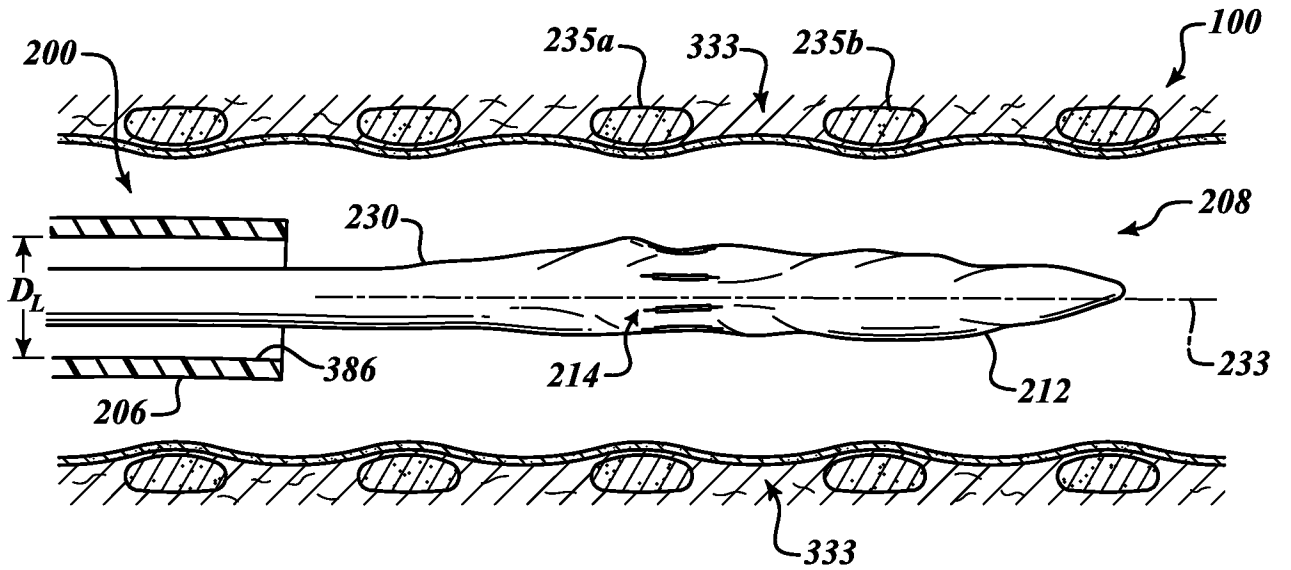


**FIG. 10**

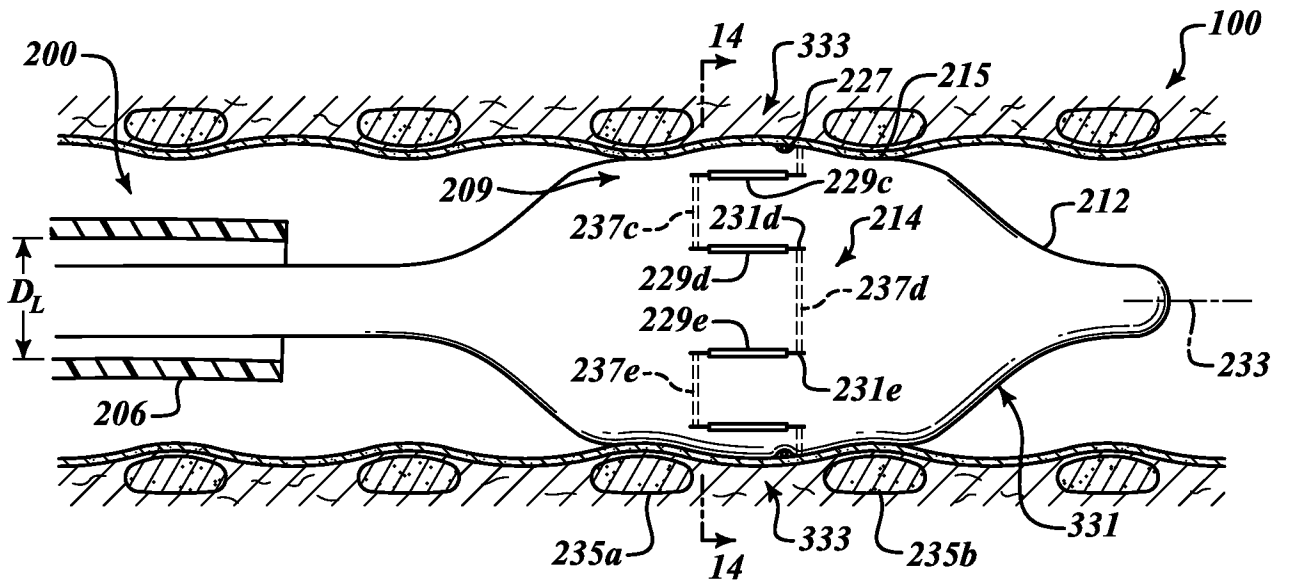


**FIG. 11**

12/29

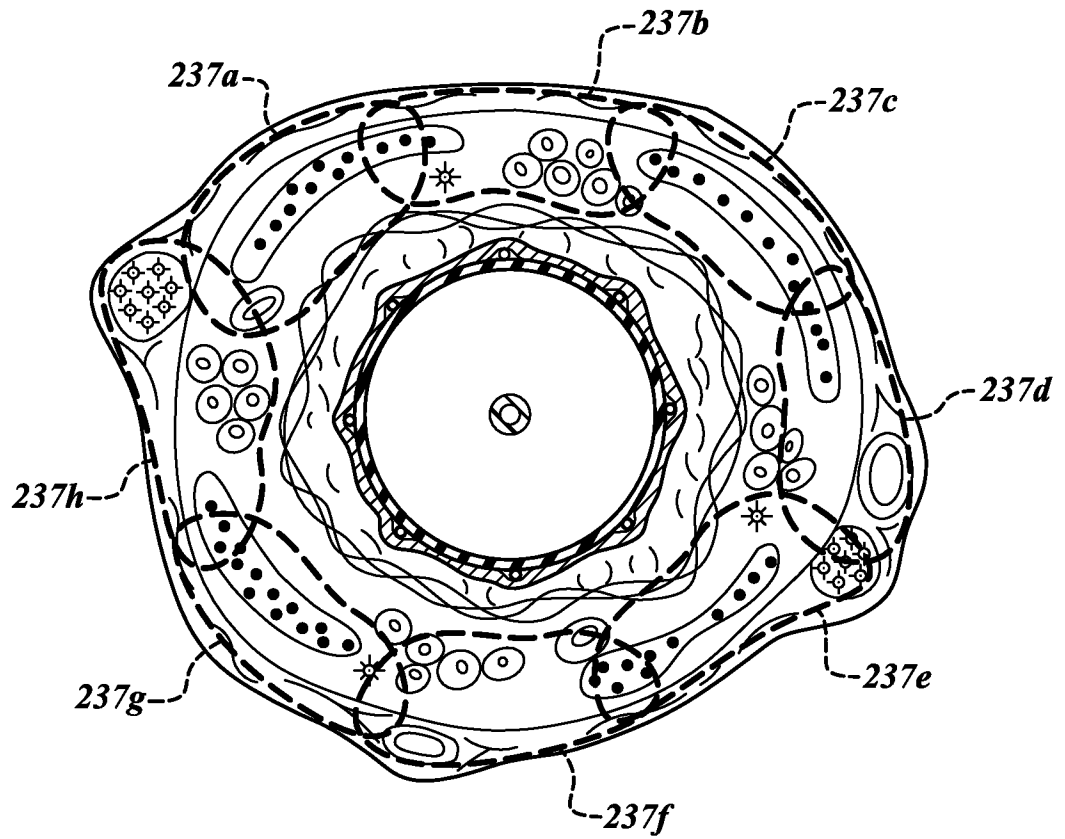


**FIG. 12**



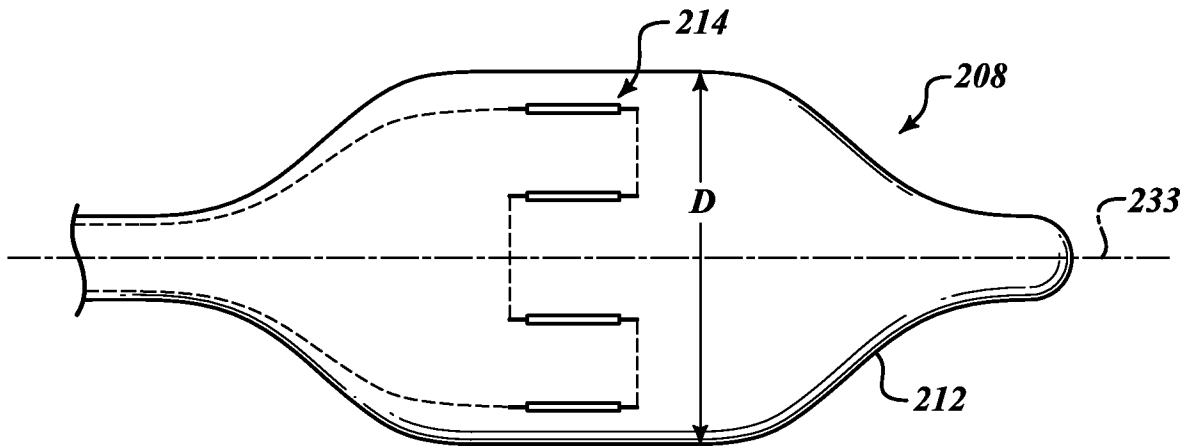
**FIG. 13**



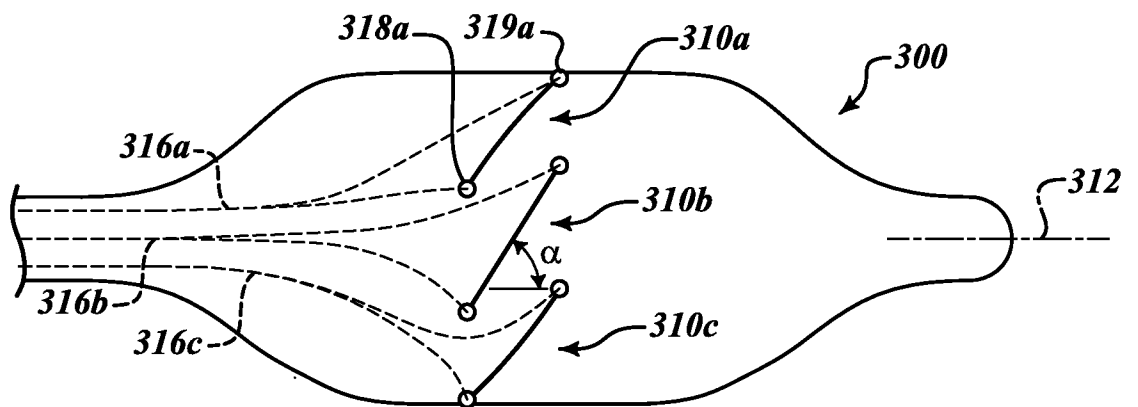


**FIG.14**

14/29

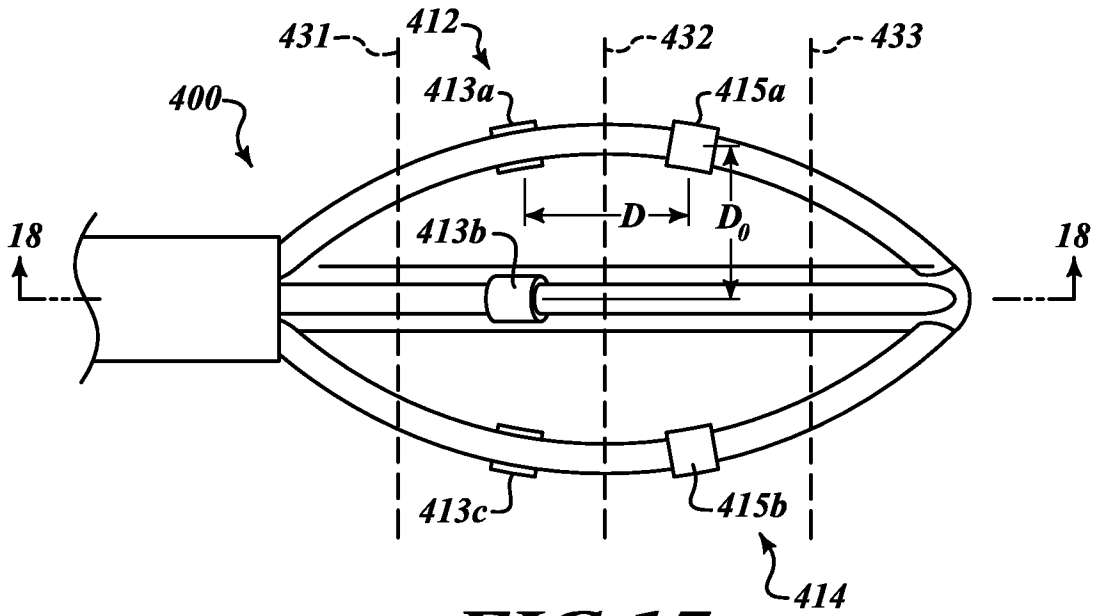


**FIG. 15**

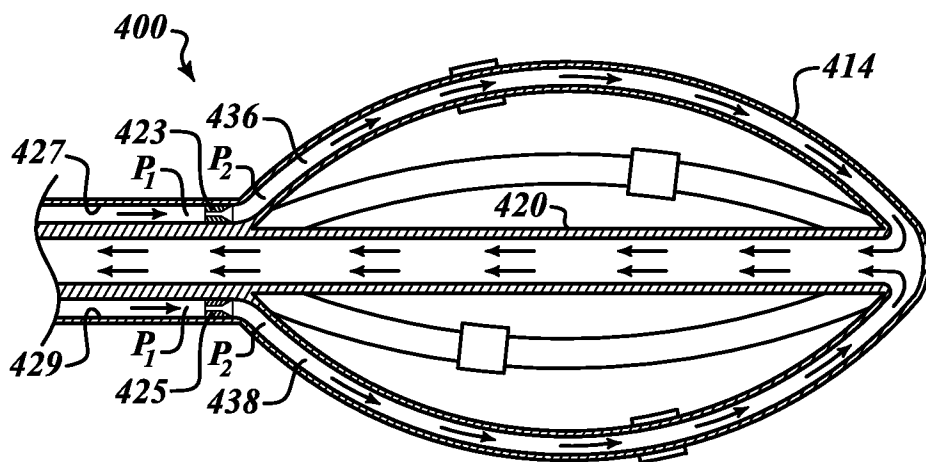


**FIG. 16**

15/29

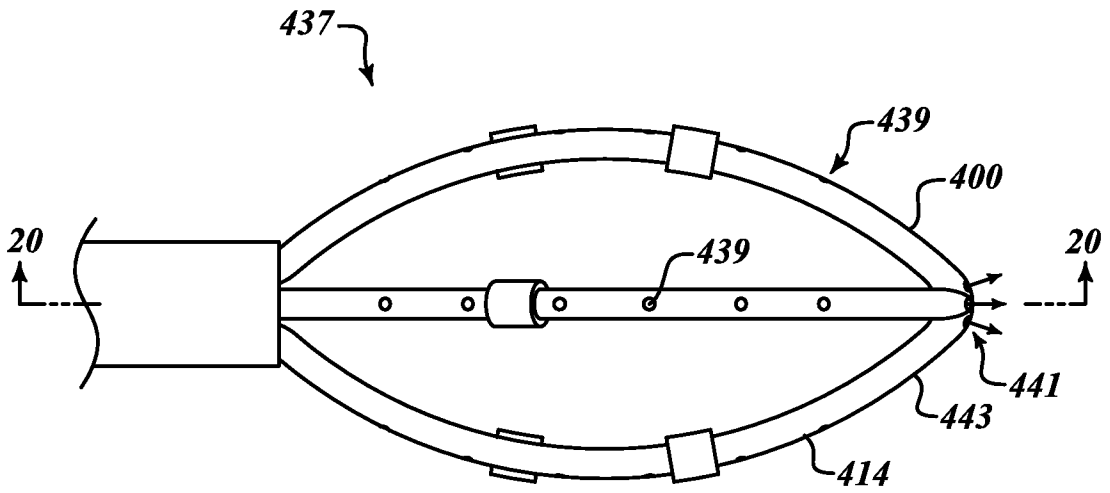


**FIG. 17**

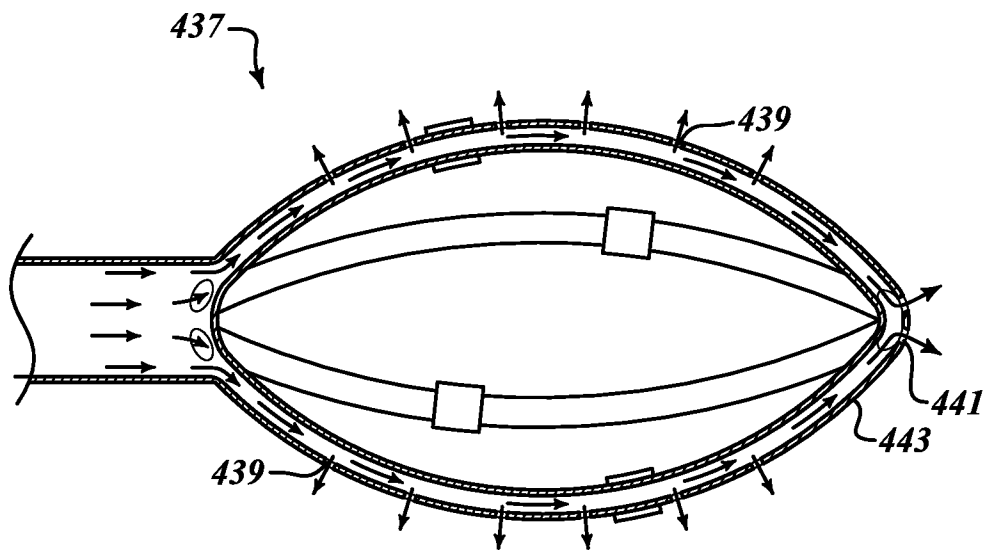


**FIG. 18**

16/29

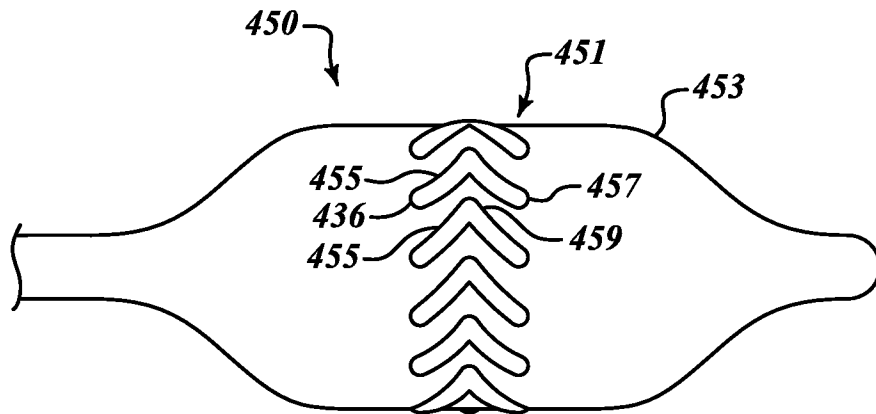


**FIG. 19**

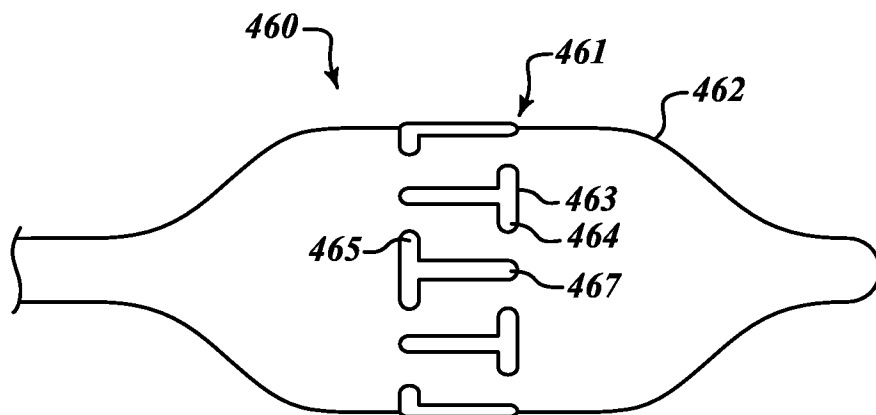


**FIG. 20**

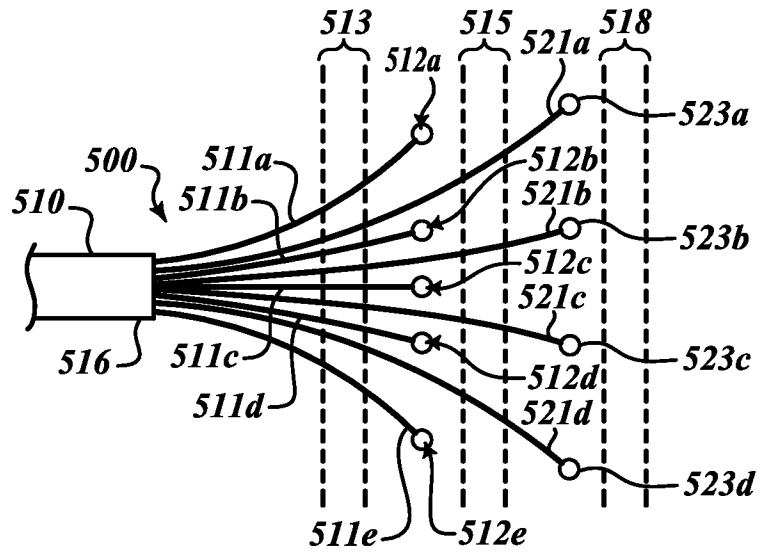
17/29



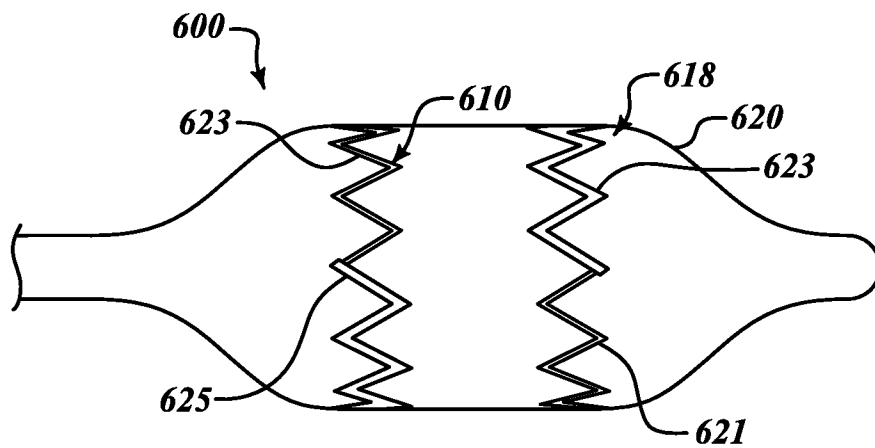
**FIG. 21**



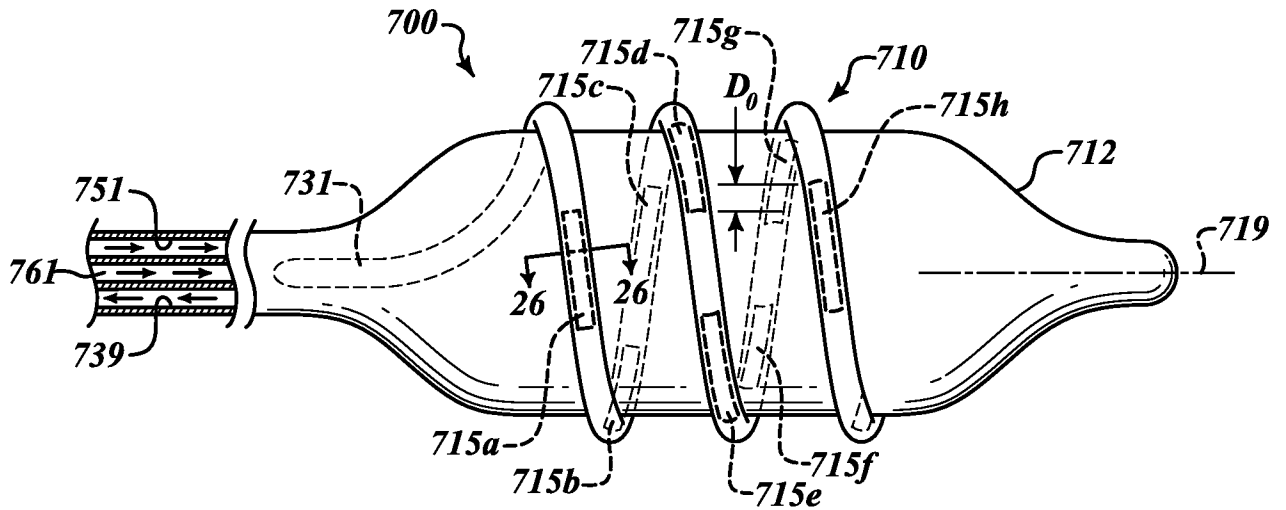
**FIG. 22**



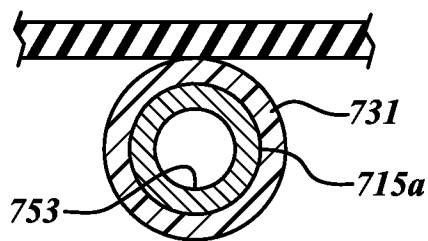
**FIG. 23**



**FIG. 24**

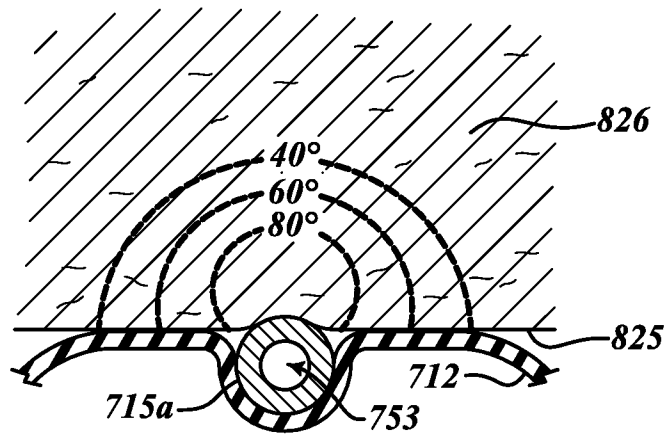


**FIG. 25**

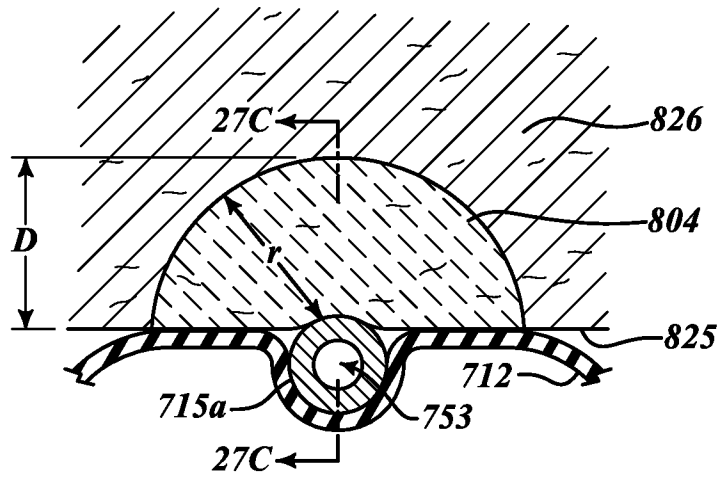


**FIG. 26**

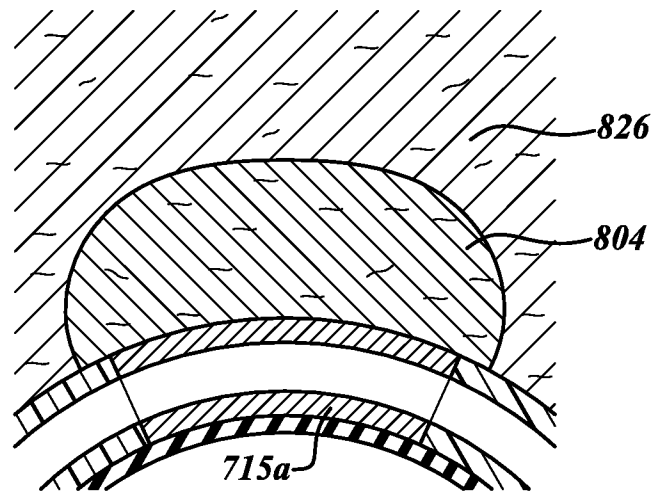
20/29



**FIG. 27A**

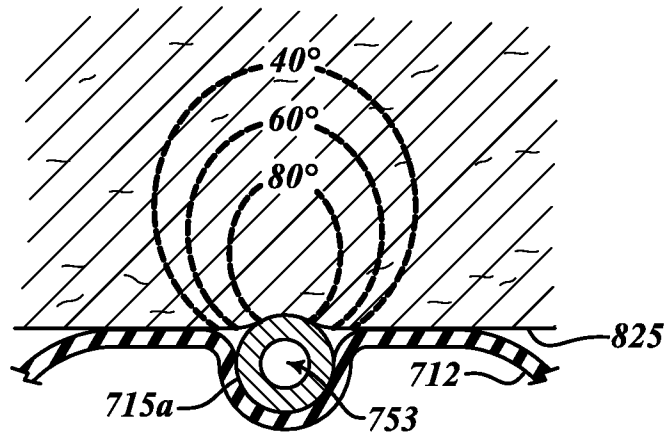


**FIG. 27B**

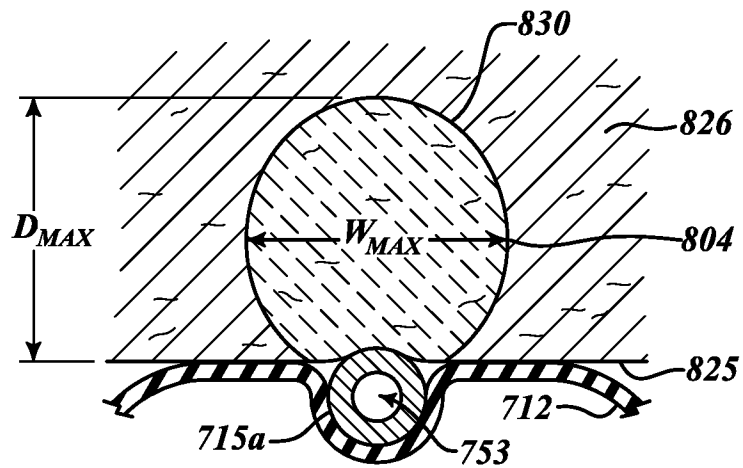


**FIG. 27C**

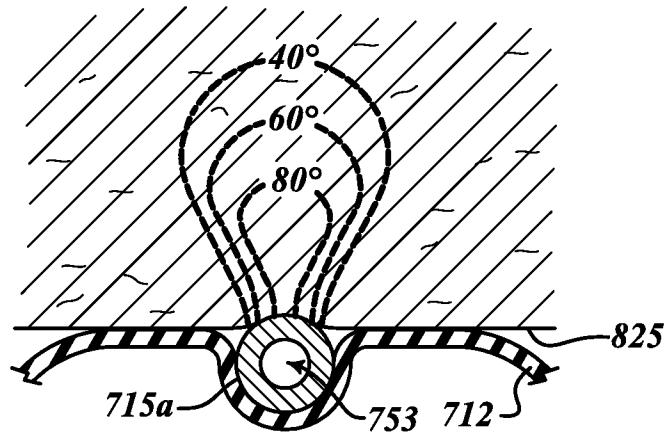




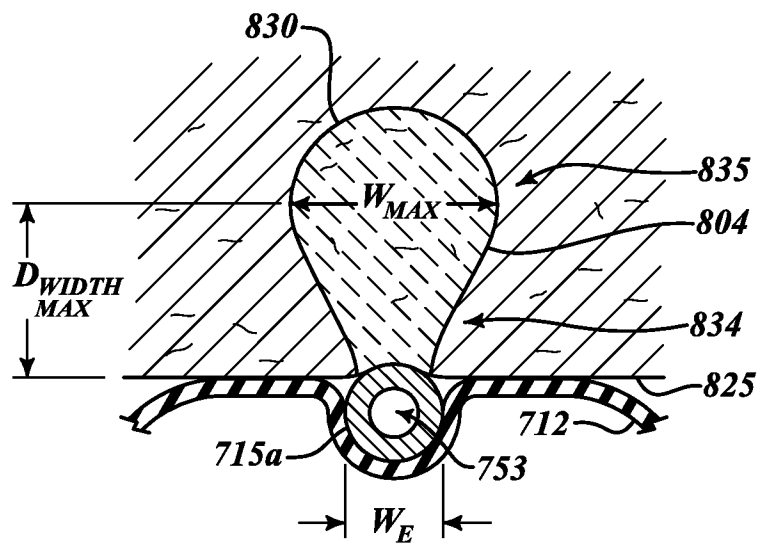
**FIG. 28A**



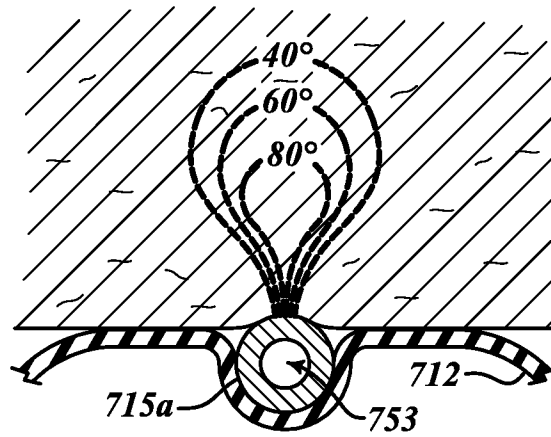
**FIG. 28B**



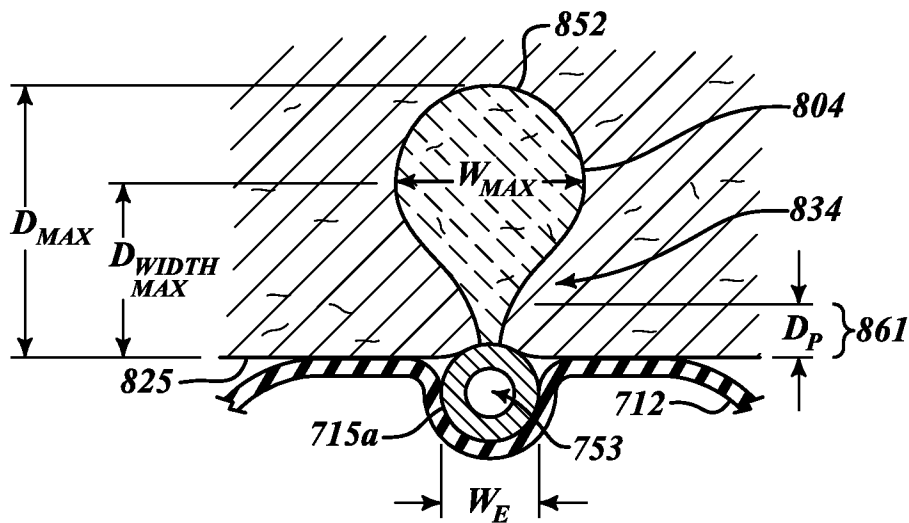
**FIG. 29A**



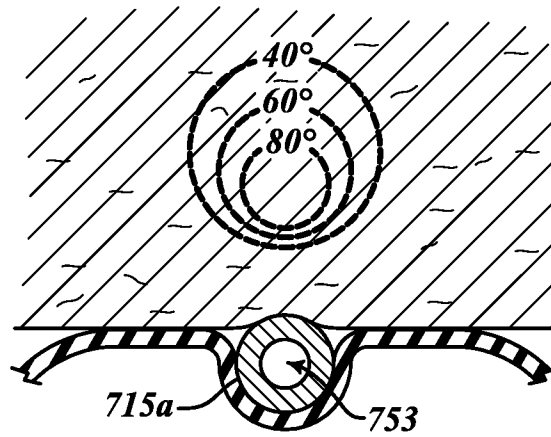
**FIG. 29B**



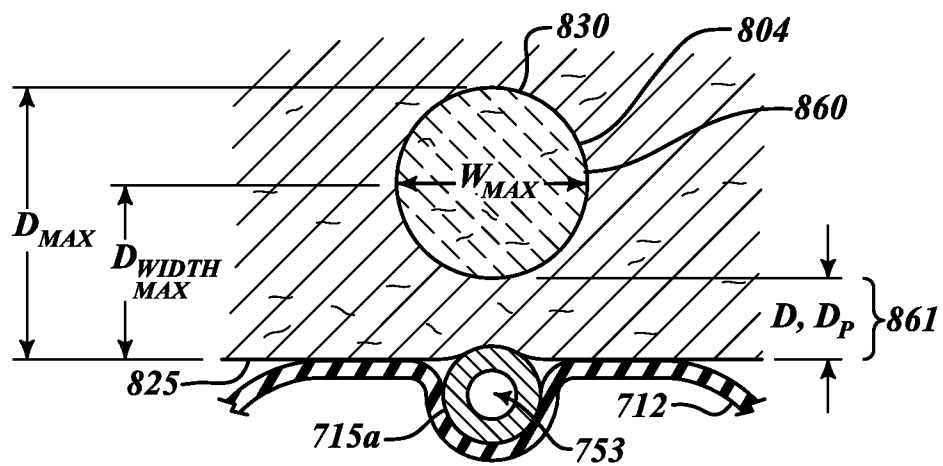
**FIG. 30A**



**FIG. 30B**

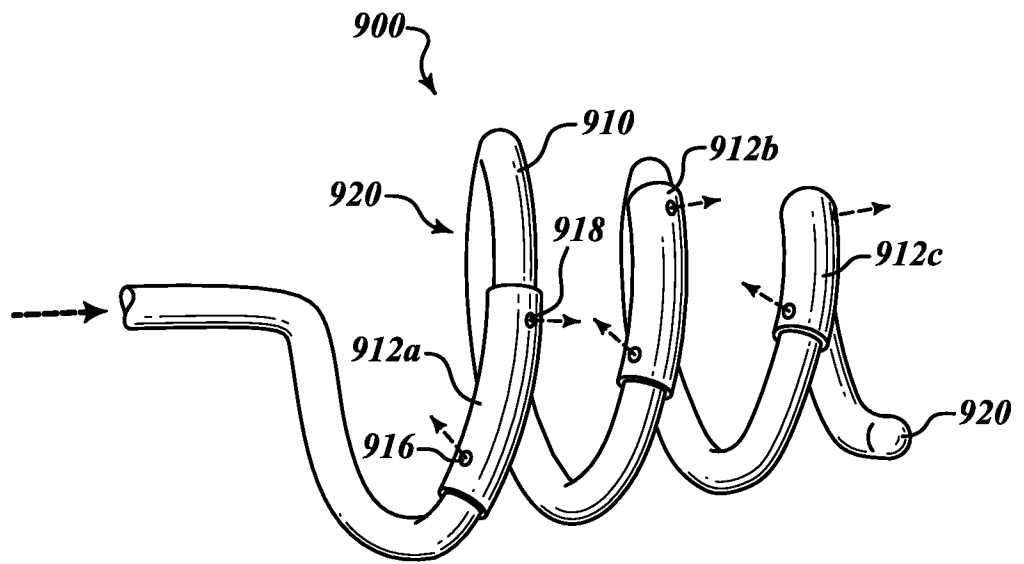


**FIG.31A**

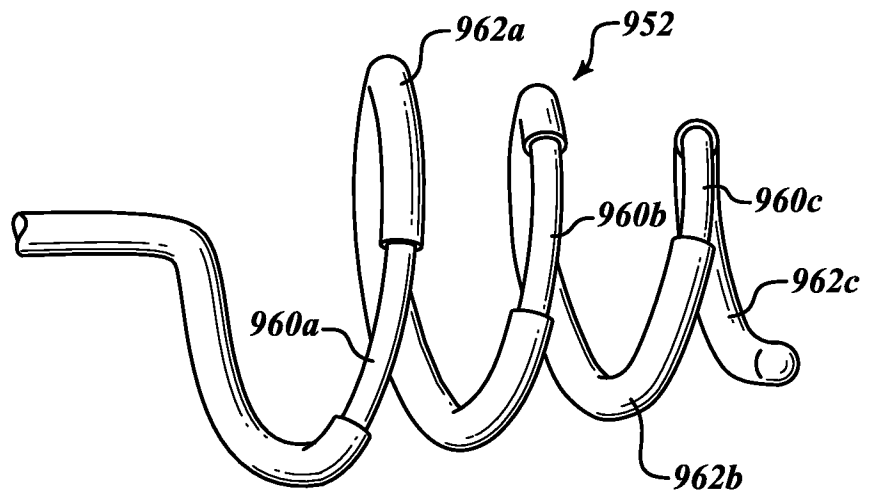


**FIG.31B**

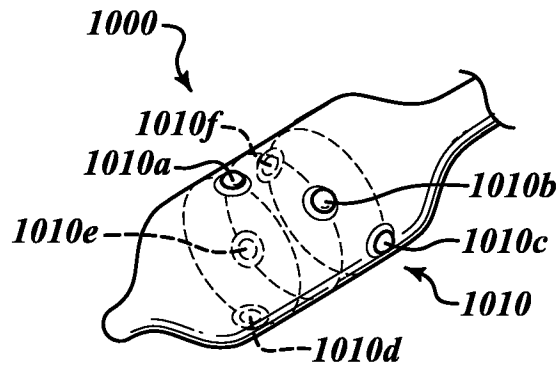
25/29



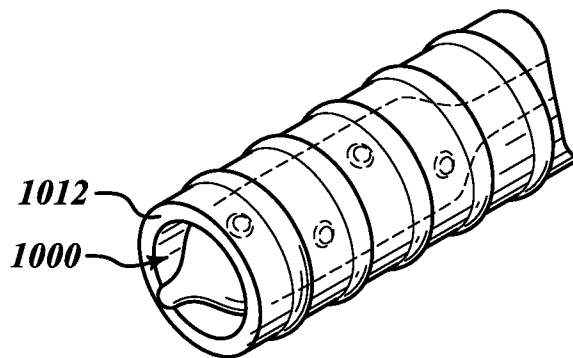
**FIG. 32**



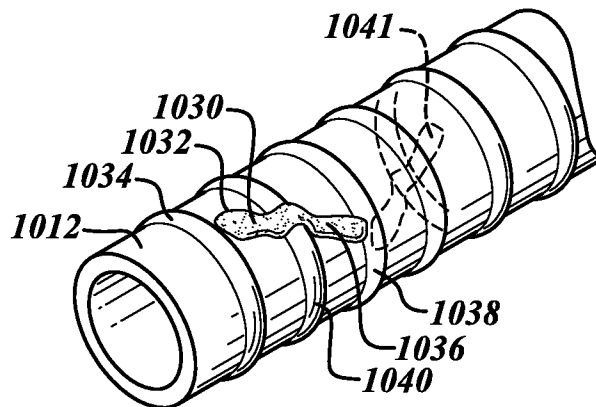
**FIG. 33**



**FIG. 34**

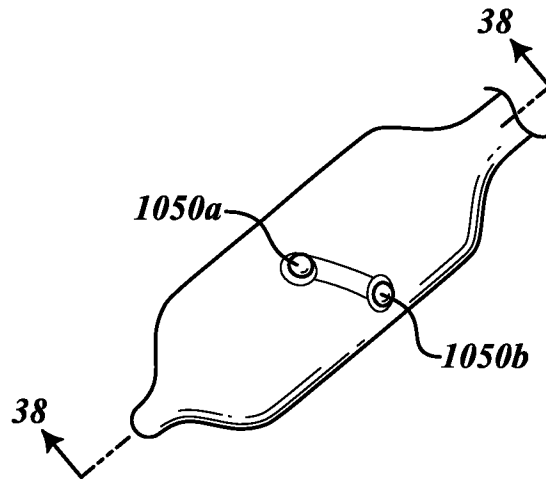


**FIG. 35**

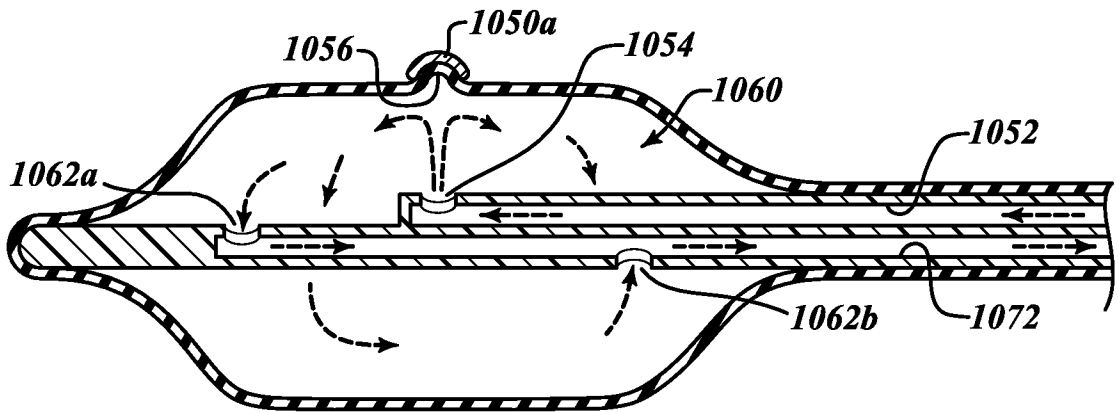


**FIG. 36**

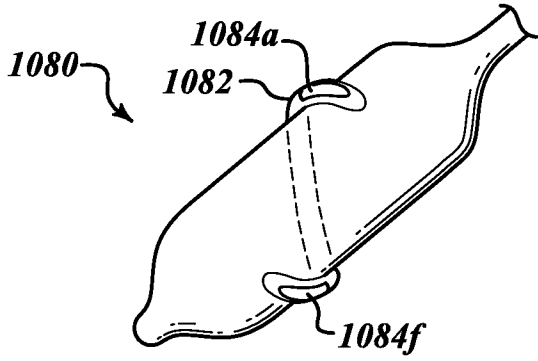
27/29



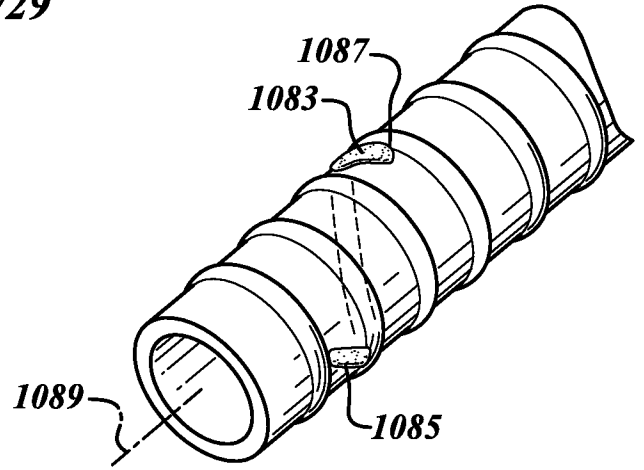
**FIG. 37**



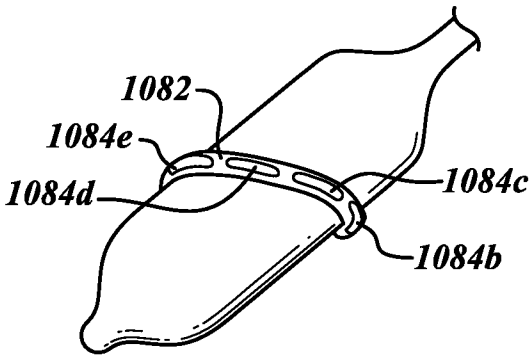
**FIG. 38**



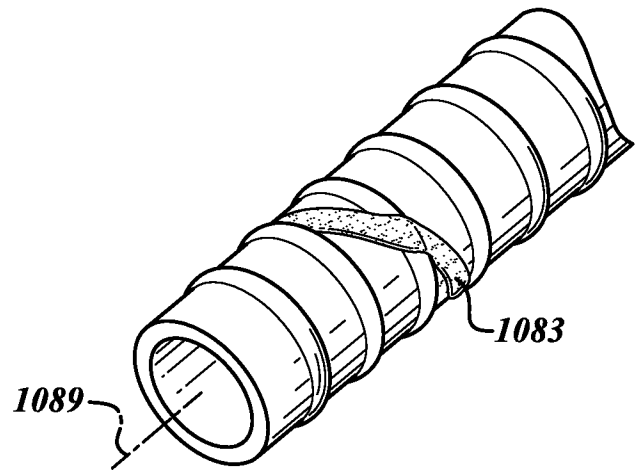
**FIG. 39A**



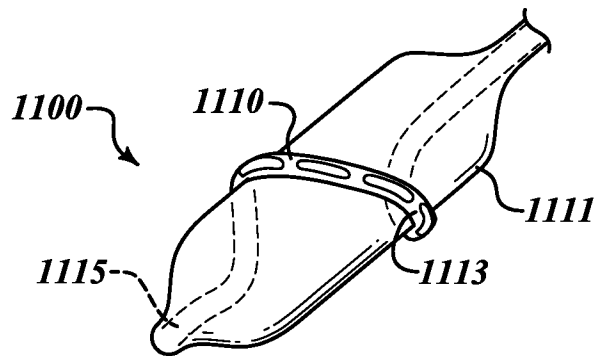
**FIG. 39B**



**FIG. 40A**



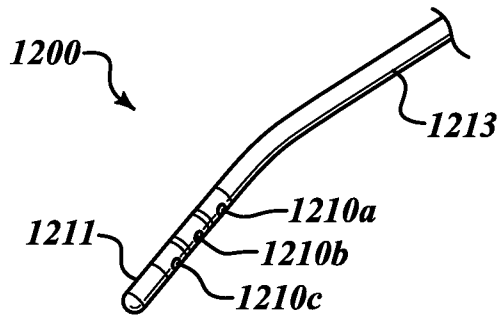
**FIG. 40B**



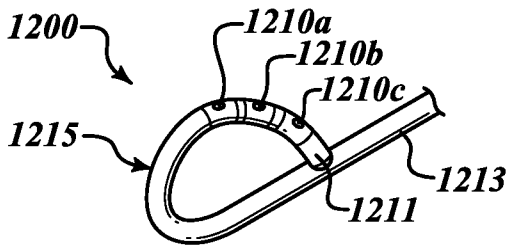
**FIG. 41**



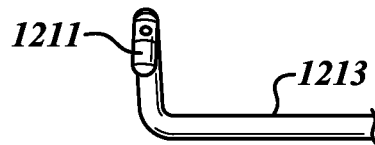
29/29



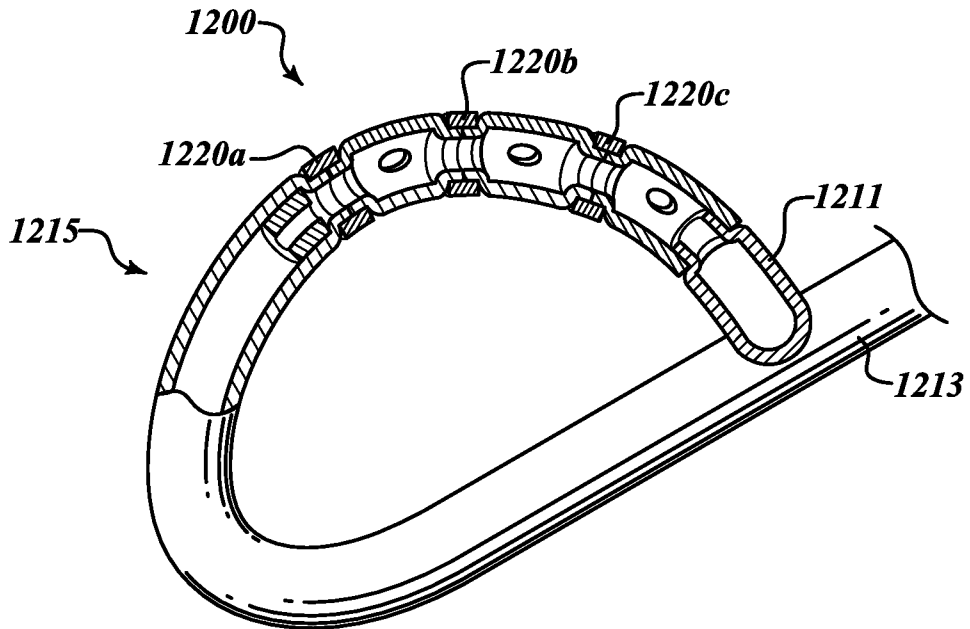
**FIG. 42**



**FIG. 43**



**FIG. 43A**



**FIG. 44**

INTERNATIONAL SEARCH REPORT

International application No  
PCT/US2010/056424

A. CLASSIFICATION OF SUBJECT MATTER  
INV. A61B18/14  
ADD.  
According to International Patent Classification (IPC) or to both national classification and IPC

B. FIELDS SEARCHED  
Minimum documentation searched (classification system followed by classification symbols)  
A61B

Documentation searched other than minimum documentation to the extent that such documents are included in the fields searched

Electronic data base consulted during the international search (name of data base and, where practical, search terms used)  
EPO-Internal

C. DOCUMENTS CONSIDERED TO BE RELEVANT

Category*	Citation of document, with indication, where appropriate, of the relevant passages	Relevant to claim No.
A	WO 97/25917 A1 (EP TECHNOLOGIES [US]) 24 July 1997 (1997-07-24) page 9, lines 23-25; figures 1,9 page 23, line 12 - line 17 page 19, line 17 - line 18	1-10
X	US 2009/131928 A1 (EDWARDS STUART D [US] ET AL) 21 May 2009 (2009-05-21)	1-6,8-10
Y	paragraph [0068] paragraph [0017]; figures 9c,27 paragraph [0058] paragraph [0085] paragraph [0065] paragraph [0057]	7
	----- -/--	

Further documents are listed in the continuation of Box C.

See patent family annex.

\* Special categories of cited documents :

- "A" document defining the general state of the art which is not considered to be of particular relevance
- "E" earlier document but published on or after the international filing date
- "L" document which may throw doubts on priority claim(s) or which is cited to establish the publication date of another citation or other special reason (as specified)
- "O" document referring to an oral disclosure, use, exhibition or other means
- "P" document published prior to the international filing date but later than the priority date claimed

- "T" later document published after the international filing date or priority date and not in conflict with the application but cited to understand the principle or theory underlying the invention
- "X" document of particular relevance; the claimed invention cannot be considered novel or cannot be considered to involve an inventive step when the document is taken alone
- "Y" document of particular relevance; the claimed invention cannot be considered to involve an inventive step when the document is combined with one or more other such documents, such combination being obvious to a person skilled in the art.
- "&" document member of the same patent family

Date of the actual completion of the international search  31 January 2011	Date of mailing of the international search report  14/04/2011
Name and mailing address of the ISA/ European Patent Office, P.B. 5818 Patentlaan 2 NL - 2280 HV Rijswijk Tel. (+31-70) 340-2040, Fax: (+31-70) 340-3016	Authorized officer  Ekstrand, Vilhelm

## INTERNATIONAL SEARCH REPORT

International application No  
PCT/US2010/056424

C(Continuation). DOCUMENTS CONSIDERED TO BE RELEVANT		
Category*	Citation of document, with indication, where appropriate, of the relevant passages	Relevant to claim No.
X	US 2008/262489 A1 (STEINKE TOM A [US]) 23 October 2008 (2008-10-23) paragraph [0088]; figure 4 paragraph [0091] paragraph [0153] paragraph [0087]	1-3,5,6, 8-10
X	----- WO 99/42047 A1 (CONWAY STUART MEDICAL INC [US]; EDWARDS STUART D [US]) 26 August 1999 (1999-08-26) page 15, line 14 - line 22; figures 18c,28 page 19, line 1 - line 3	1-6,8-10
Y	----- WO 00/66017 A1 (CURON MEDICAL INC [US]) 9 November 2000 (2000-11-09) figures 55-56 -----	7

# INTERNATIONAL SEARCH REPORT

International application No.  
PCT/US2010/056424

## Box No. II Observations where certain claims were found unsearchable (Continuation of item 2 of first sheet)

This international search report has not been established in respect of certain claims under Article 17(2)(a) for the following reasons:

1.  Claims Nos.: 20-38, 47-51  
because they relate to subject matter not required to be searched by this Authority, namely:  
see FURTHER INFORMATION sheet PCT/ISA/210
2.  Claims Nos.:  
because they relate to parts of the international application that do not comply with the prescribed requirements to such an extent that no meaningful international search can be carried out, specifically:
3.  Claims Nos.:  
because they are dependent claims and are not drafted in accordance with the second and third sentences of Rule 6.4(a).

## Box No. III Observations where unity of invention is lacking (Continuation of item 3 of first sheet)

This International Searching Authority found multiple inventions in this international application, as follows:

see additional sheet

1.  As all required additional search fees were timely paid by the applicant, this international search report covers all searchable claims.
2.  As all searchable claims could be searched without effort justifying an additional fees, this Authority did not invite payment of additional fees.
3.  As only some of the required additional search fees were timely paid by the applicant, this international search report covers only those claims for which fees were paid, specifically claims Nos.:
4.  No required additional search fees were timely paid by the applicant. Consequently, this international search report is restricted to the invention first mentioned in the claims; it is covered by claims Nos.:

1-10

### Remark on Protest

- The additional search fees were accompanied by the applicant's protest and, where applicable, the payment of a protest fee.
- The additional search fees were accompanied by the applicant's protest but the applicable protest fee was not paid within the time limit specified in the invitation.
- No protest accompanied the payment of additional search fees.

**FURTHER INFORMATION CONTINUED FROM PCT/ISA/ 210**

Continuation of Box II.1

Claims Nos.: 20-38, 47-51

Independent Claims 20,25,32,47 refer to methods for treating a subject involving the steps of introducing catheter into the airway and subsequently deliver energy to it. Thus, according to Rule 39.1 (iv) PCT, no search is required to be carried out on claims 20-38 and 47-51 because they disclose a method for treatment of the human body by surgery. Further, according to Art 43bis.1 PCT and Rule 67.1 PCT, no international preliminary examination is required to be carried out on these claims.

**FURTHER INFORMATION CONTINUED FROM PCT/ISA/ 210**

This International Searching Authority found multiple (groups of) inventions in this international application, as follows:

1. claims: 1-10

A energy delivery device with incorporated cooling

---

2. claims: 11-19

A intraluminal delivery device with complete circumferential lesions

---

3. claims: 39-46

A energy delivery device with oblique angled lesions

---

# INTERNATIONAL SEARCH REPORT

Information on patent family members

International application No

PCT/US2010/056424

Patent document cited in search report	Publication date	Patent family member(s)	Publication date
WO 9725917	A1	24-07-1997	CA 2243595 A1 24-07-1997
			EP 0879015 A1 25-11-1998
			JP 2000504242 T 11-04-2000
-----			
US 2009131928	A1	21-05-2009	AU 2224499 A 02-08-1999
			CA 2318315 A1 22-07-1999
			EP 1047348 A1 02-11-2000
			JP 2002508989 T 26-03-2002
			WO 9935986 A1 22-07-1999
			US 2002115991 A1 22-08-2002
			US 2006009758 A1 12-01-2006
-----			
US 2008262489	A1	23-10-2008	NONE
-----			
WO 9942047	A1	26-08-1999	AU 2972699 A 06-09-1999
			AU 5641200 A 13-02-2001
			CA 2391301 A1 01-02-2001
			EP 1196105 A1 17-04-2002
			JP 2003505140 T 12-02-2003
			WO 0106942 A1 01-02-2001
			US 6009877 A 04-01-2000
			US 2002139379 A1 03-10-2002
-----			
WO 0066017	A1	09-11-2000	AU 4696100 A 17-11-2000
			US 2002107515 A1 08-08-2002
-----			