



US 20100082098A1

(19) **United States**
(12) **Patent Application Publication**
Starksen et al.

(10) **Pub. No.: US 2010/0082098 A1**
(43) **Pub. Date: Apr. 1, 2010**

(54) **DELIVERY DEVICES AND METHODS FOR HEART VALVE REPAIR**

(76) Inventors: **Niel F. Starksen**, Los Altos, CA (US); **John To**, Newark, CA (US); **Mariel Fabro**, San Jose, CA (US); **Michael F. Wei**, Redwood City, CA (US); **Rodolfo A. Morales**, Los Gatos, CA (US)

Correspondence Address:
MORRISON & FOERSTER LLP
755 PAGE MILL RD
PALO ALTO, CA 94304-1018 (US)

(21) Appl. No.: **12/581,040**
(22) Filed: **Oct. 16, 2009**

Related U.S. Application Data

(60) Division of application No. 10/901,555, filed on Jul. 27, 2004, which is a continuation-in-part of application No. 10/792,681, filed on Mar. 2, 2004, which is a continuation-in-part of application No. 10/741,130, filed on Dec. 19, 2003, which is a continuation-in-part of application No. 10/656,797, filed on Sep. 4, 2003, which is a continuation-in-part of application No. 10/461,043, filed on Jun. 13, 2003, now Pat. No. 6,986,775.

(60) Provisional application No. 60/459,735, filed on Apr. 1, 2003, provisional application No. 60/388,935, filed on Jun. 13, 2002, provisional application No. 60/429,288, filed on Nov. 25, 2002, provisional application No. 60/445,890, filed on Feb. 6, 2003, provisional application No. 60/462,502, filed on Apr. 10, 2003.

Publication Classification

(51) **Int. Cl.**
A61F 2/24 (2006.01)
(52) **U.S. Cl.** **623/2.11**

(57) **ABSTRACT**

Devices, systems and methods facilitate positioning of a cardiac valve annulus treatment device, thus enhancing treatment of the annulus. Methods generally involve advancing an anchor delivery device through vasculature of the patient to a location in the heart for treating the valve annulus, contacting the anchor delivery device with a length of the valve annulus, delivering a plurality of coupled anchors from the anchor delivery device to secure the anchors to the annulus, and drawing the anchors together to circumferentially tighten the valve annulus. Devices generally include an elongate catheter having at least one tensioning member and at least one tensioning actuator for deforming a distal portion of the catheter to help it conform to a valve annulus. The catheter device may be used to navigate a subannular space below a mitral valve to facilitate positioning of an anchor delivery device.

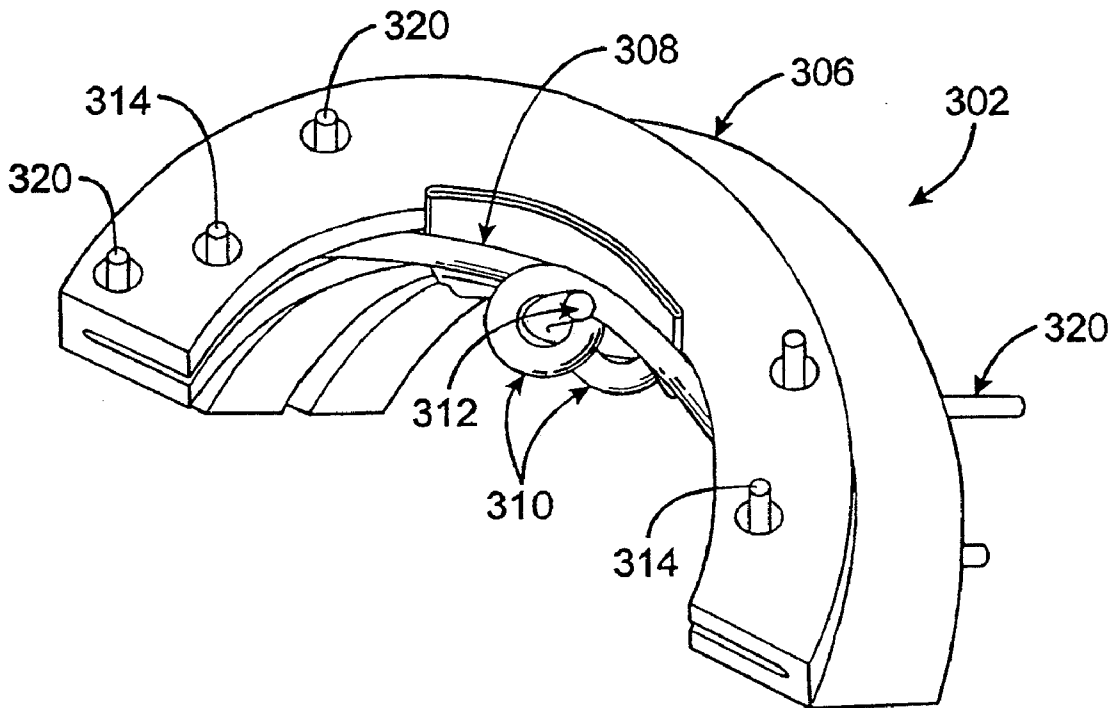

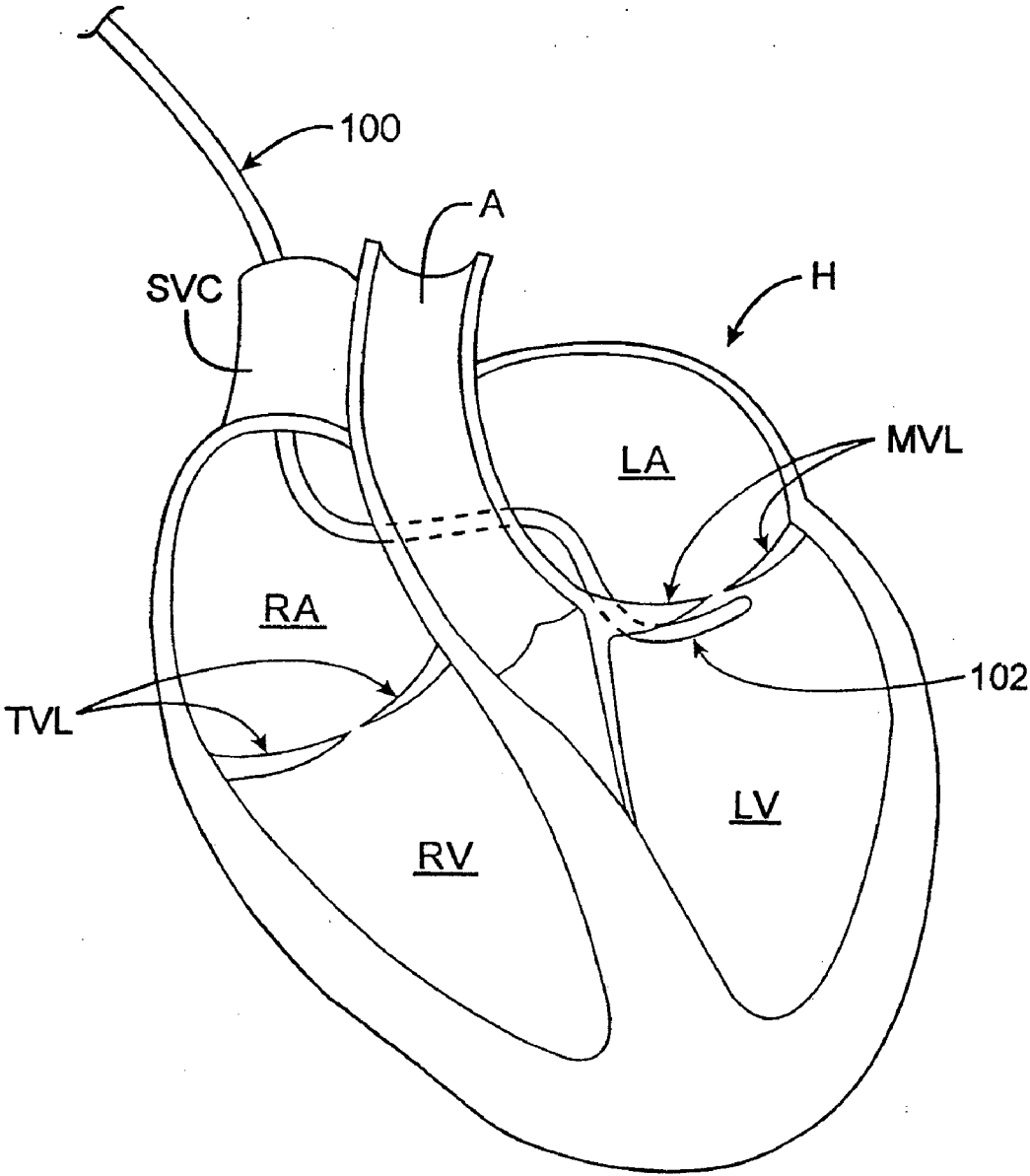

FIG. 1

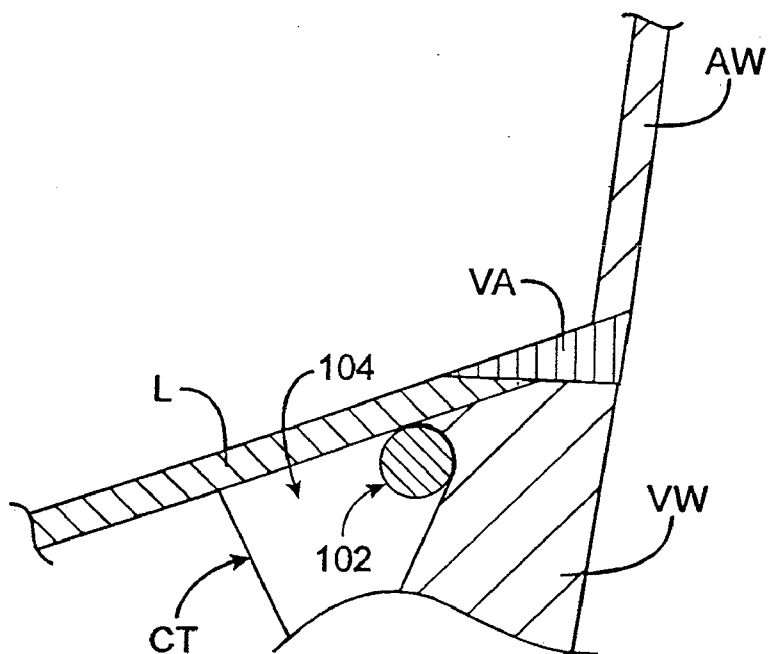

FIG. 2A

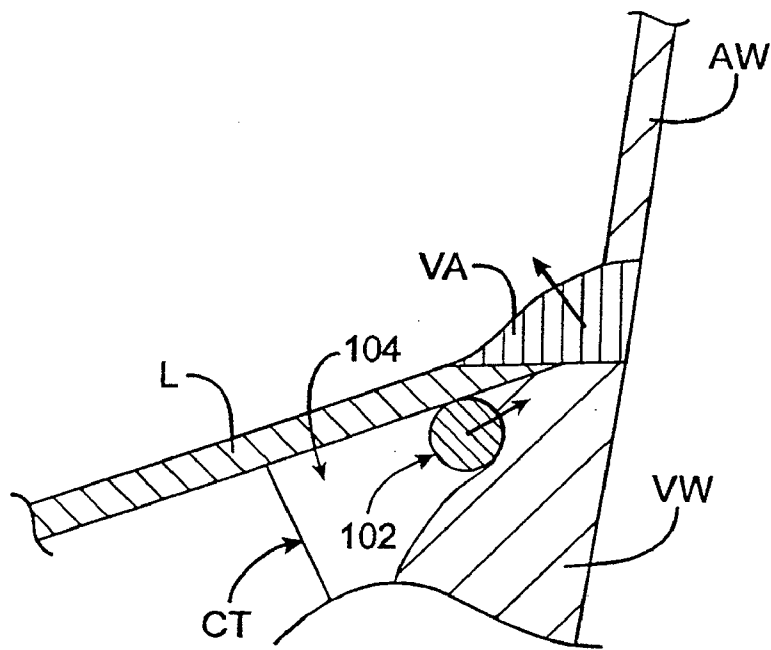

FIG. 2B

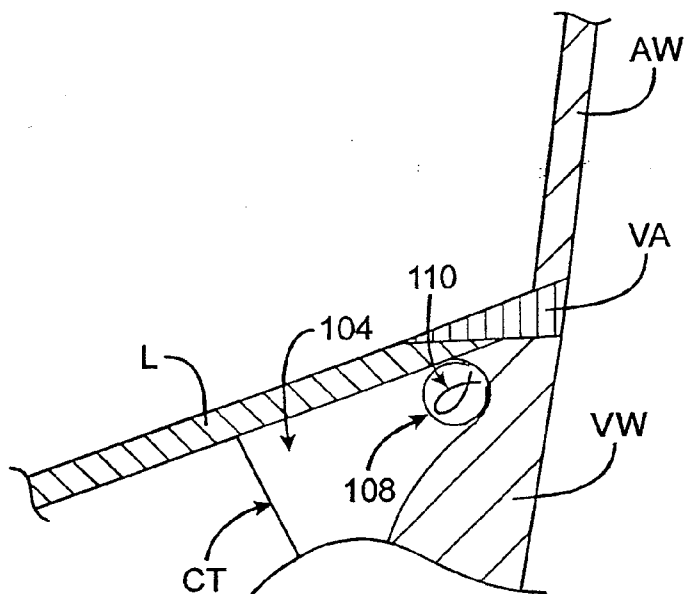

FIG. 2C

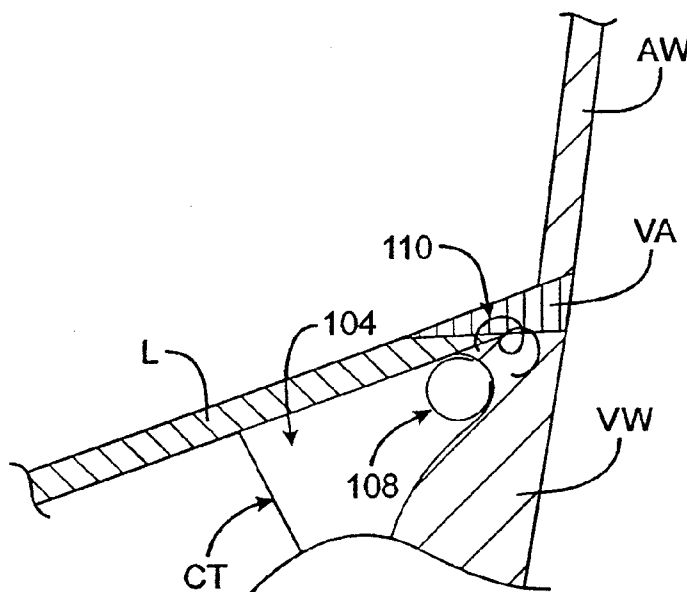

FIG. 2D

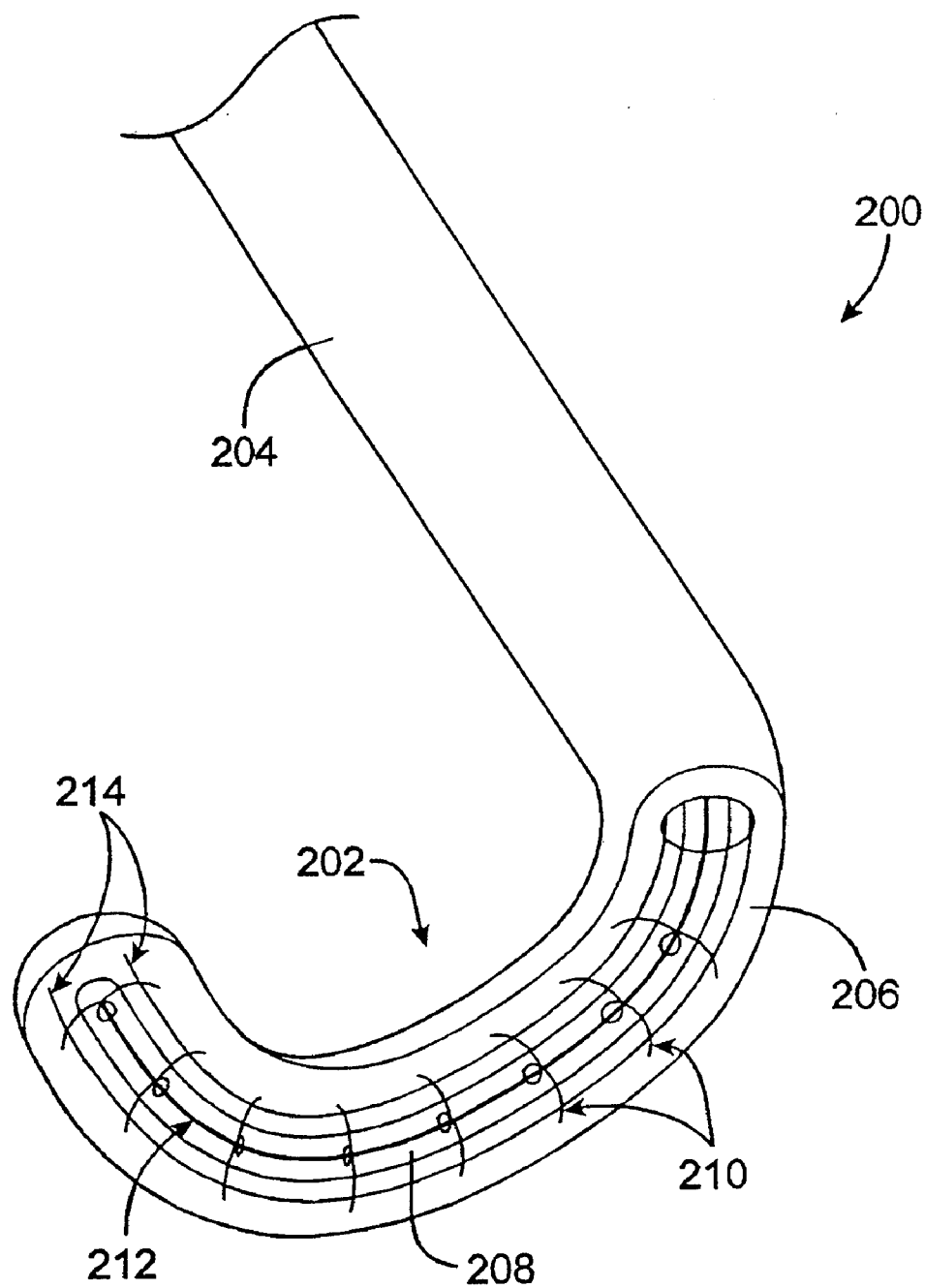

FIG. 3

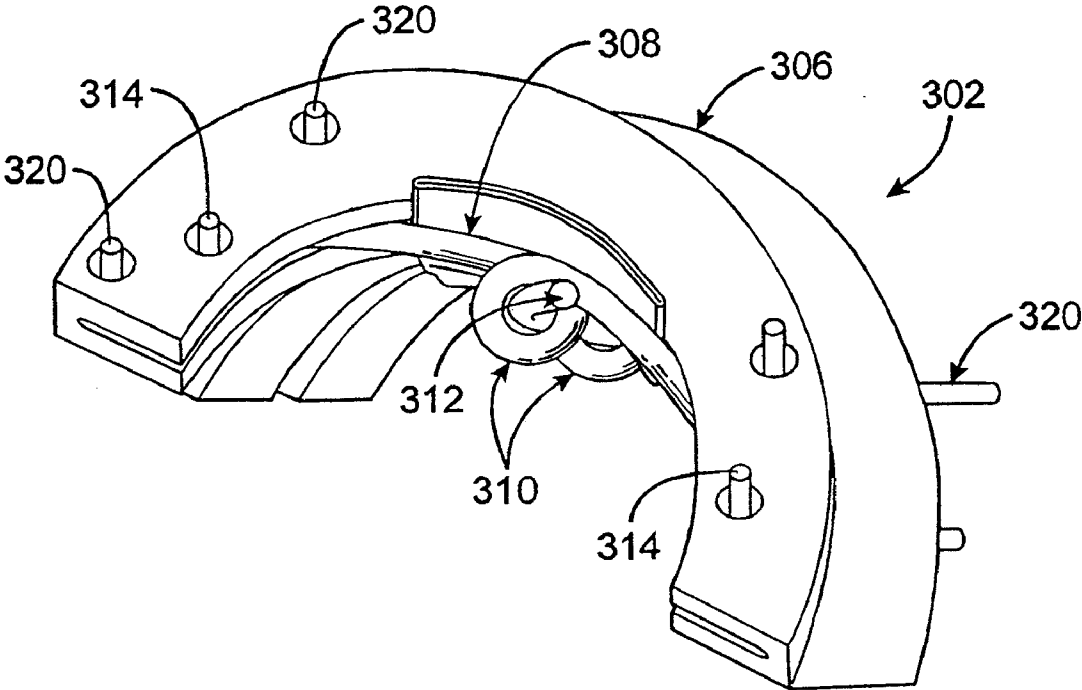

FIG. 4

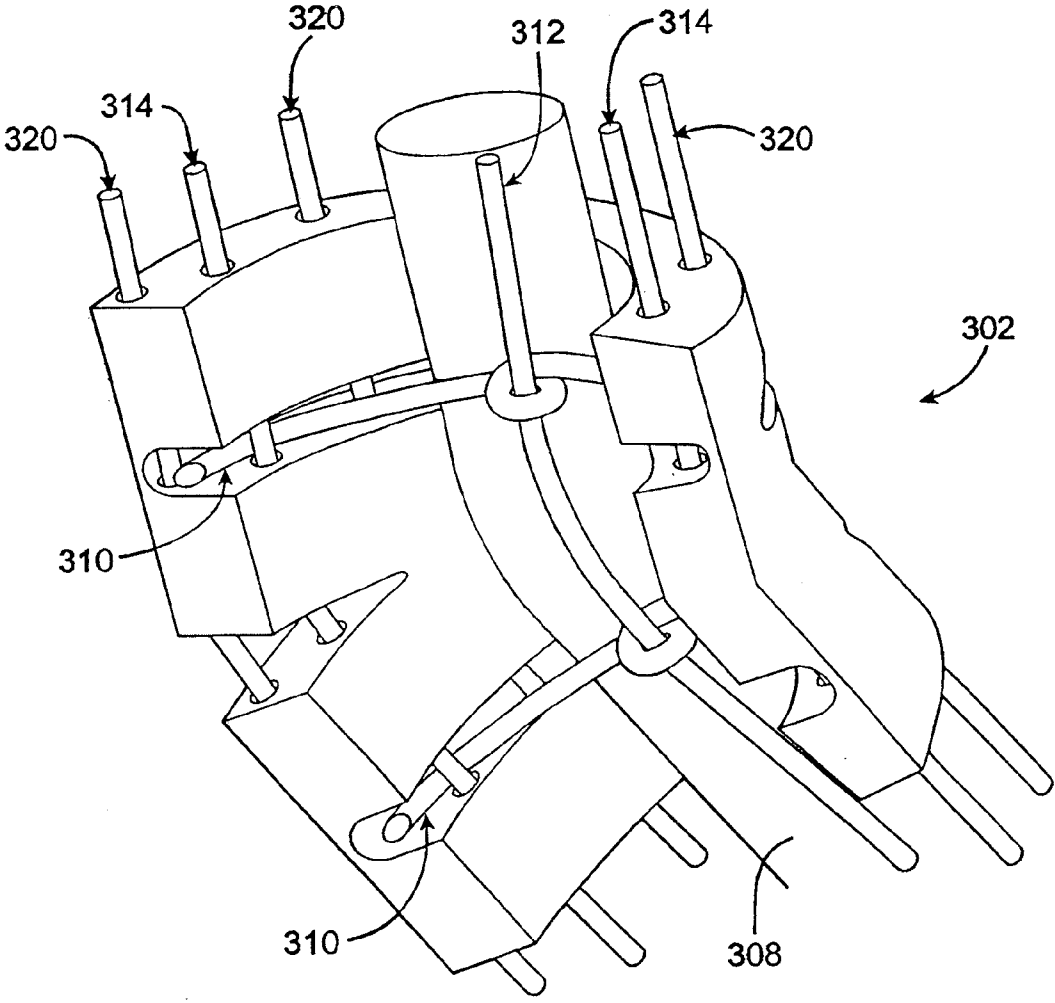

FIG. 5

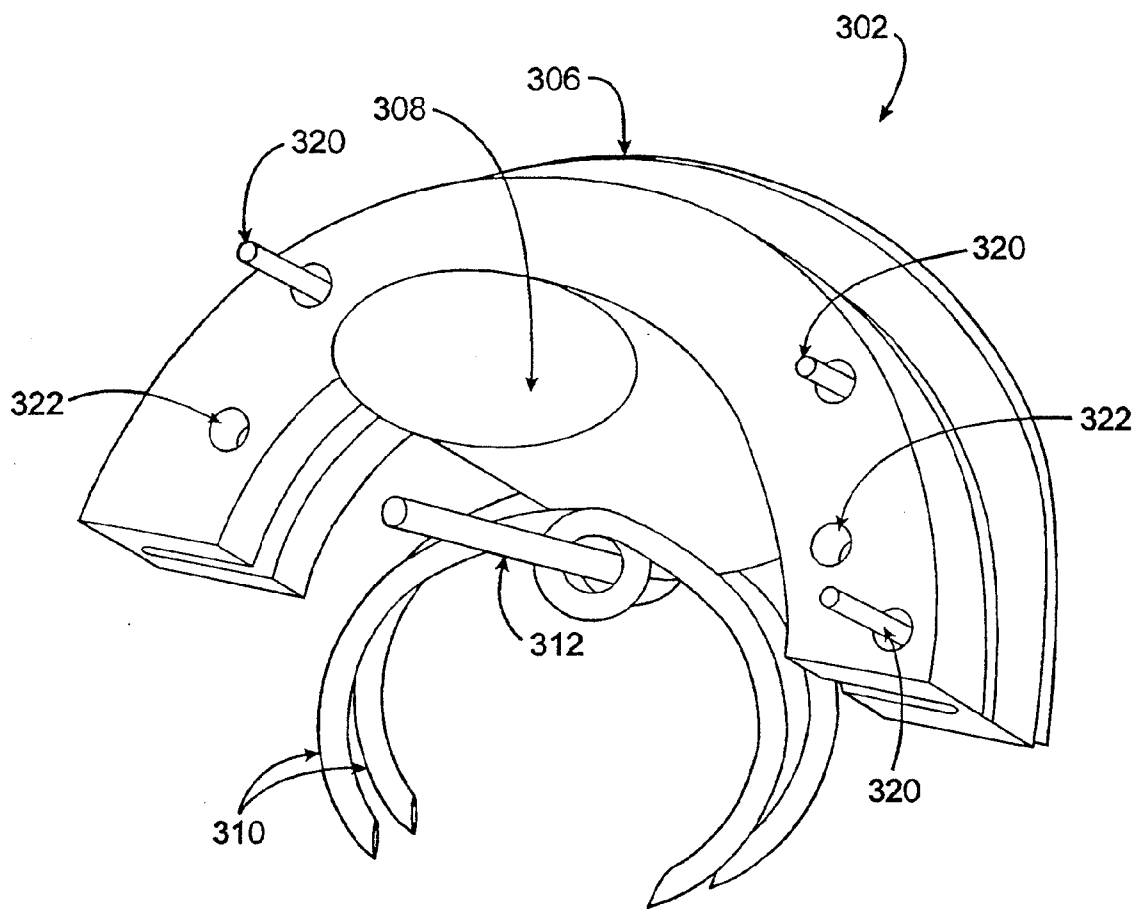
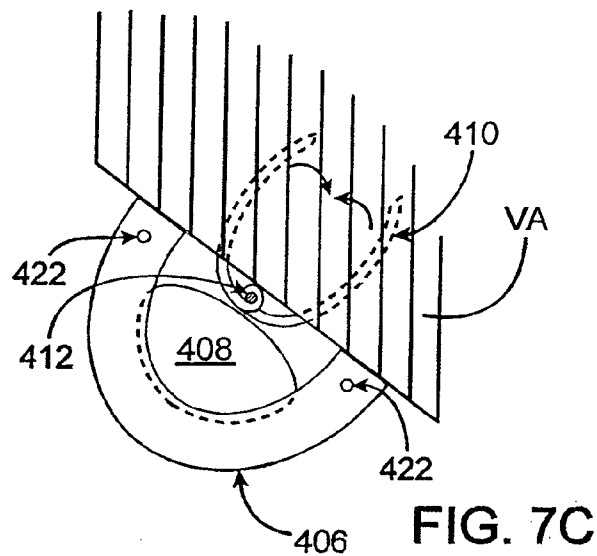
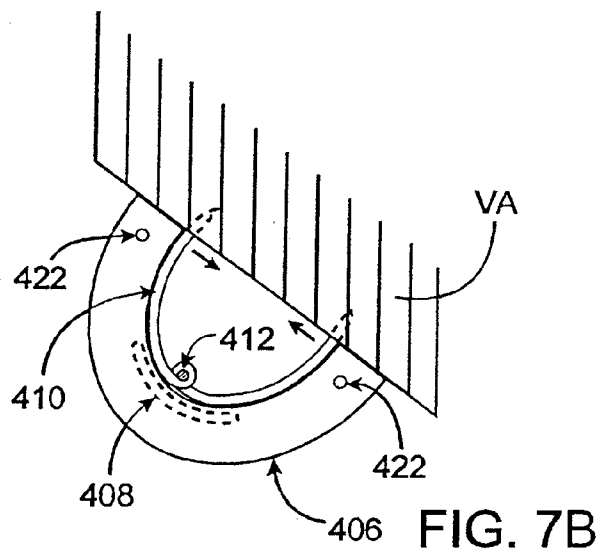
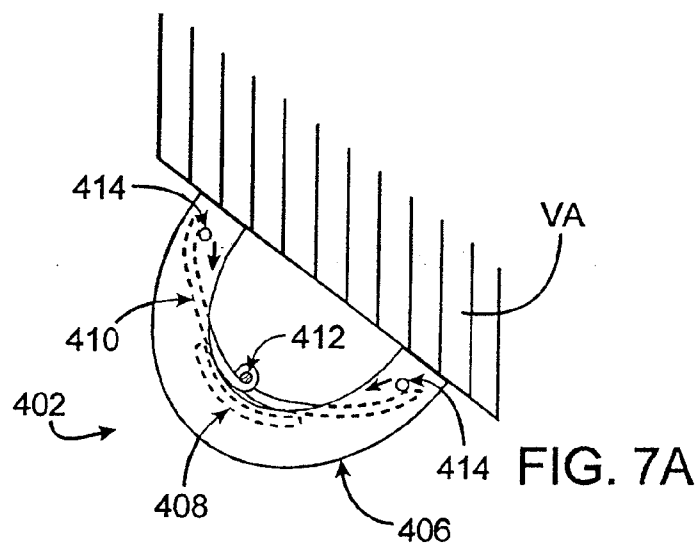

FIG. 6



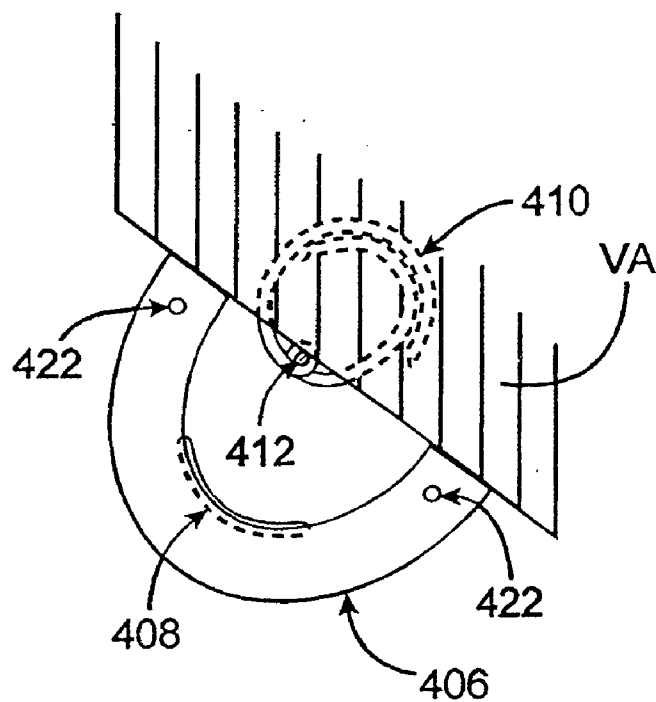

FIG. 7D

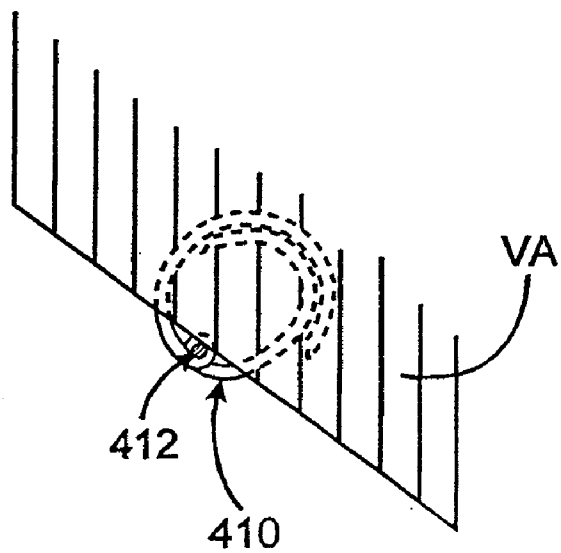

FIG. 7E

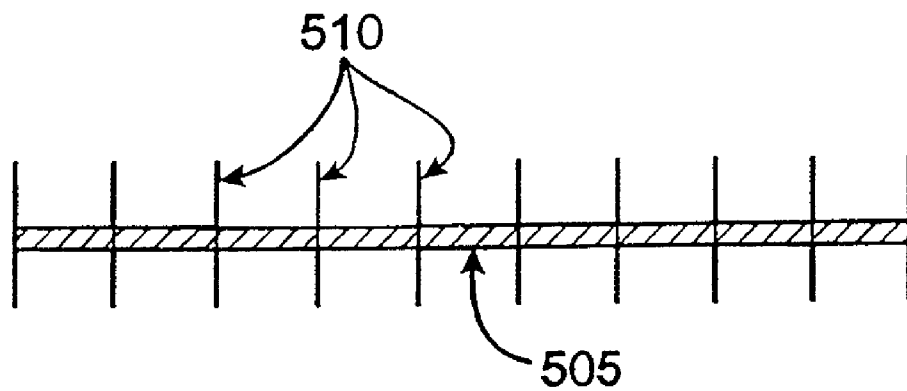

FIG. 8A

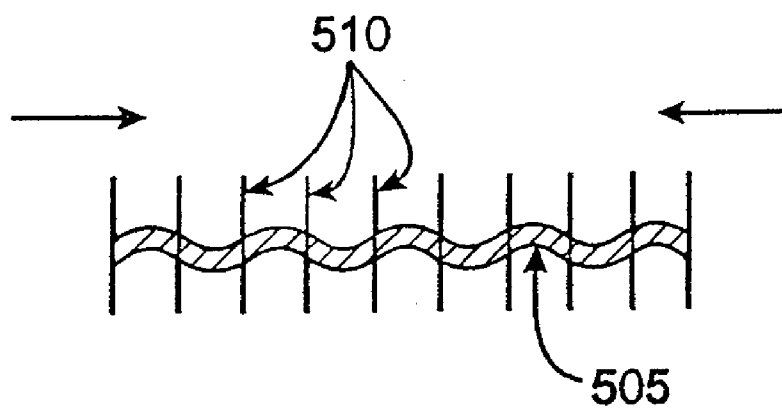

FIG. 8B

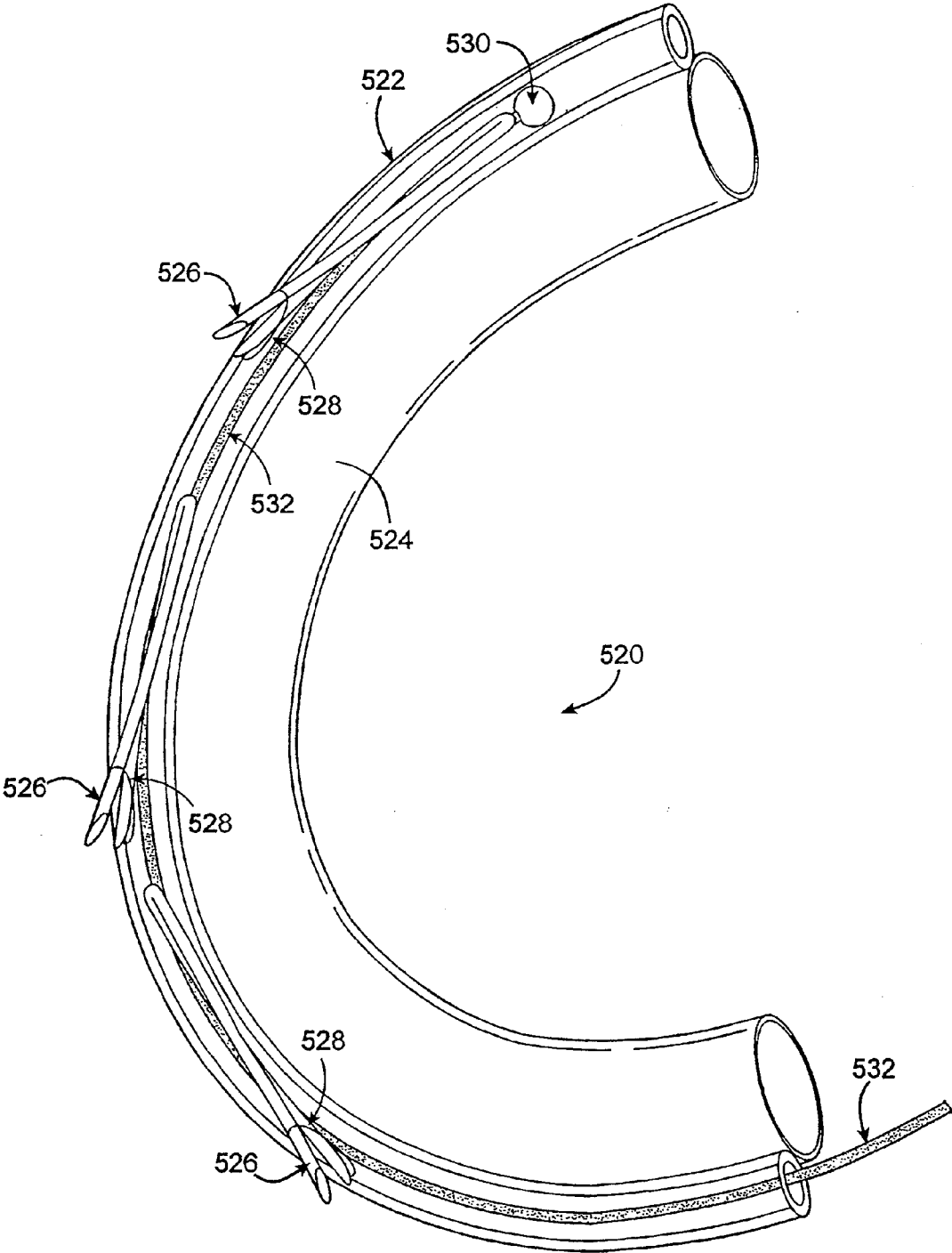

FIG. 9A

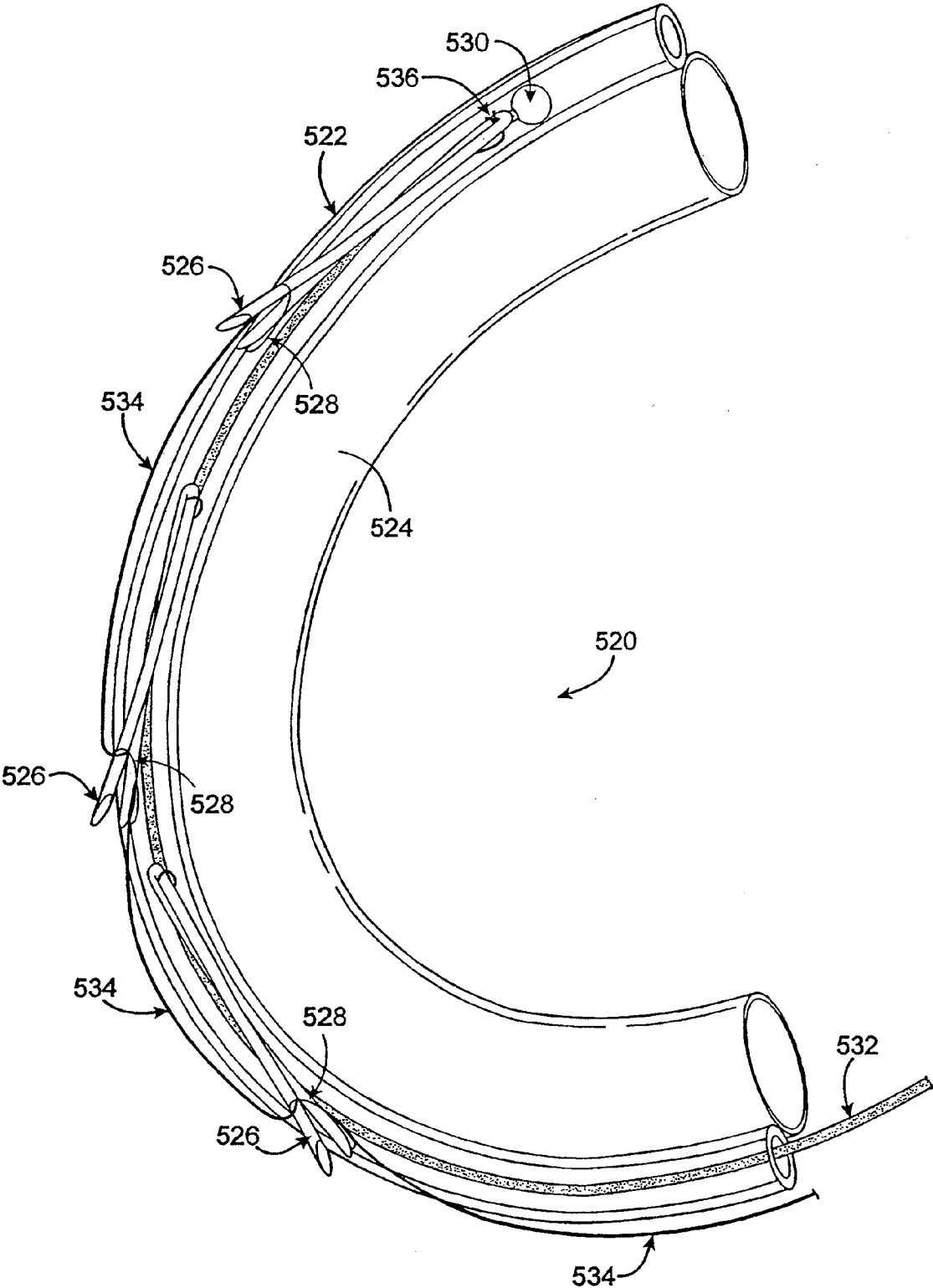

FIG. 9B

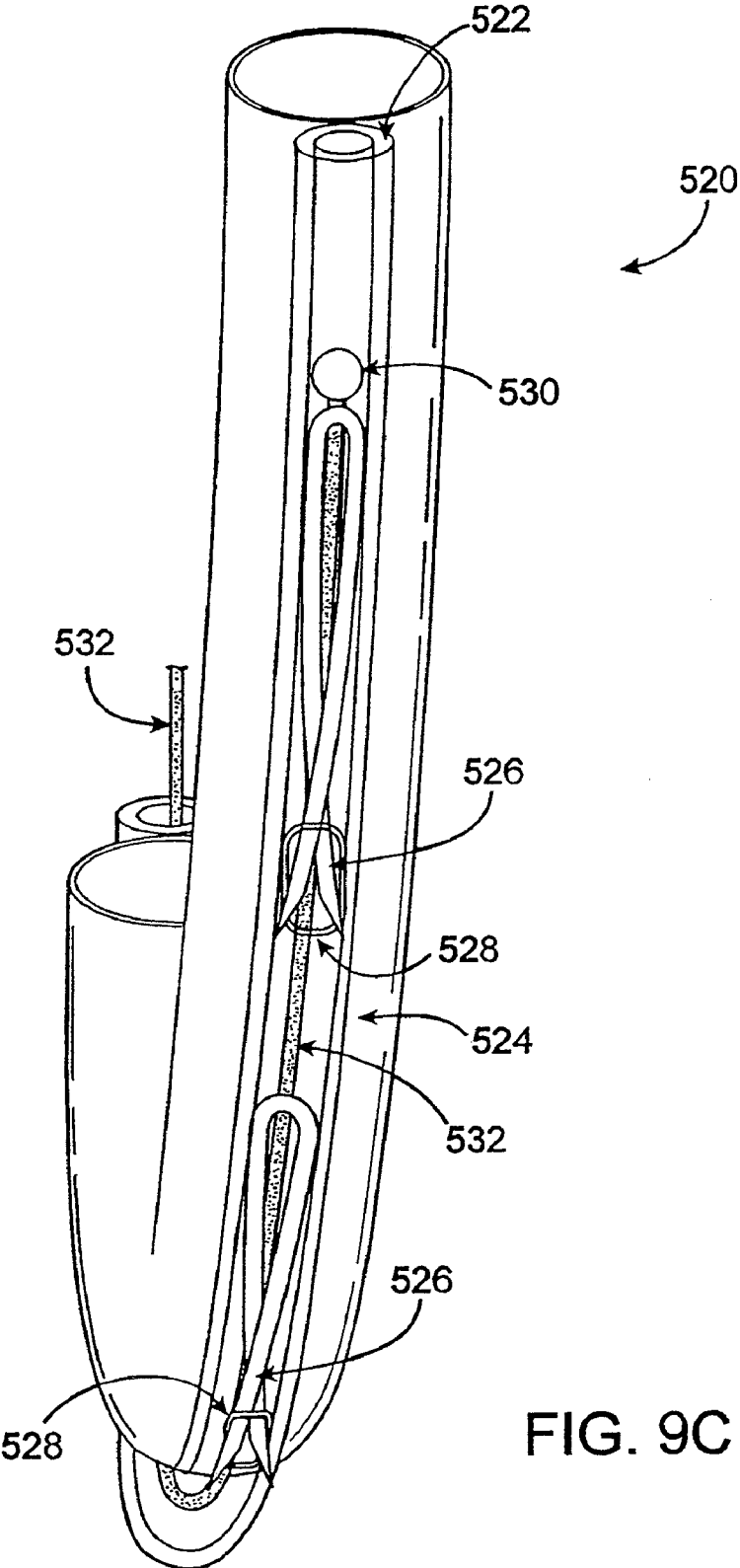

FIG. 9C

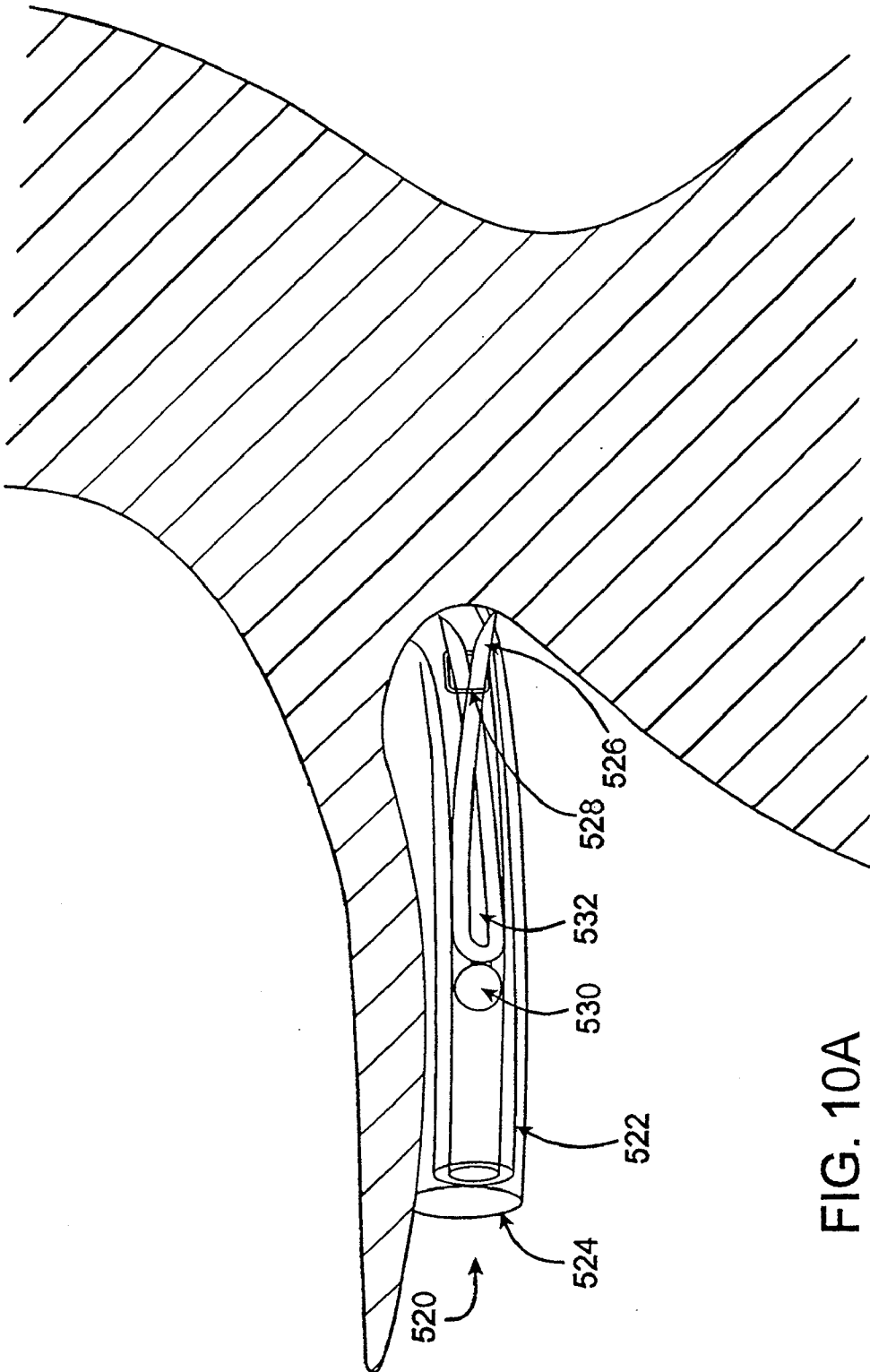

FIG. 10A

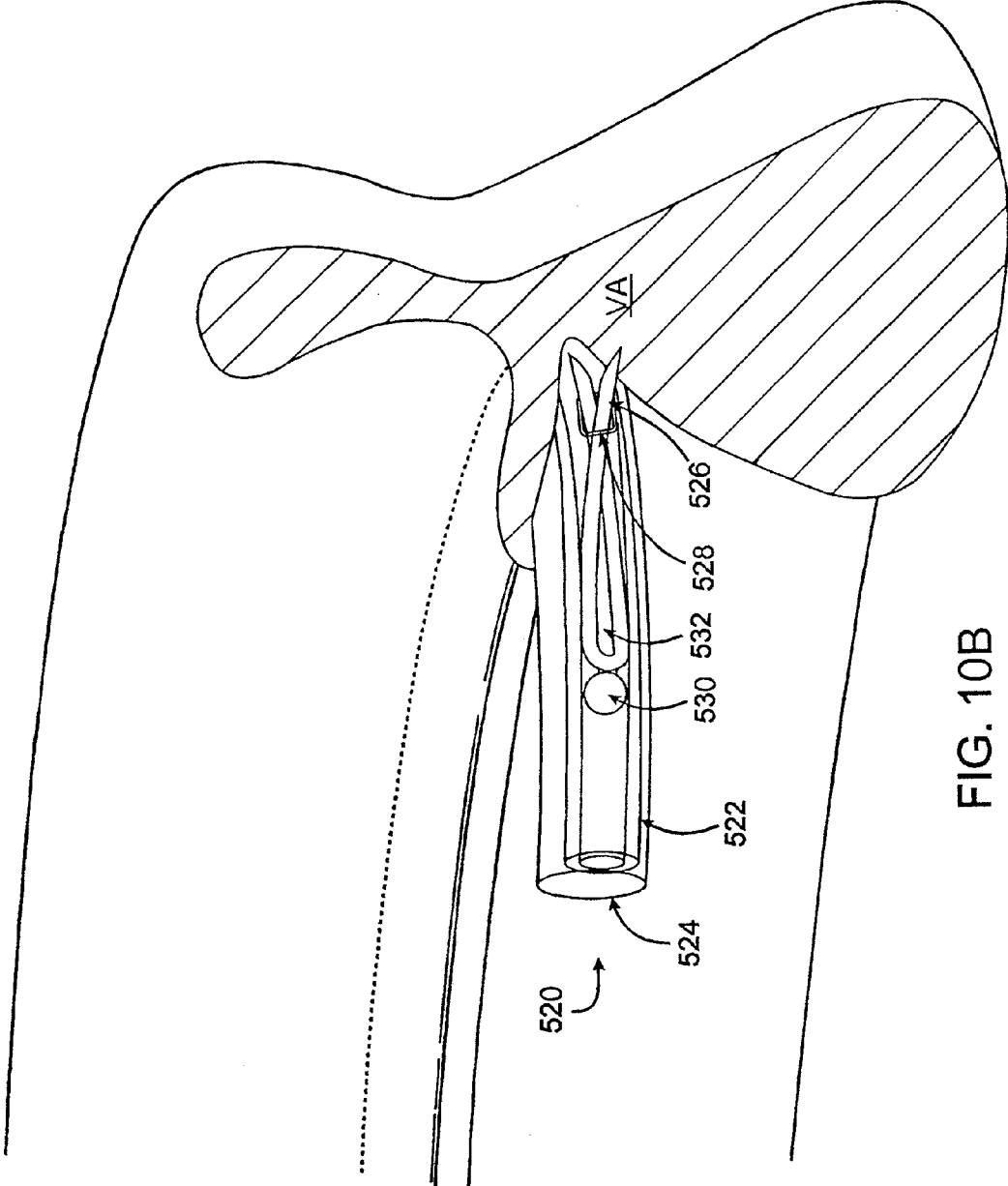

FIG. 10B

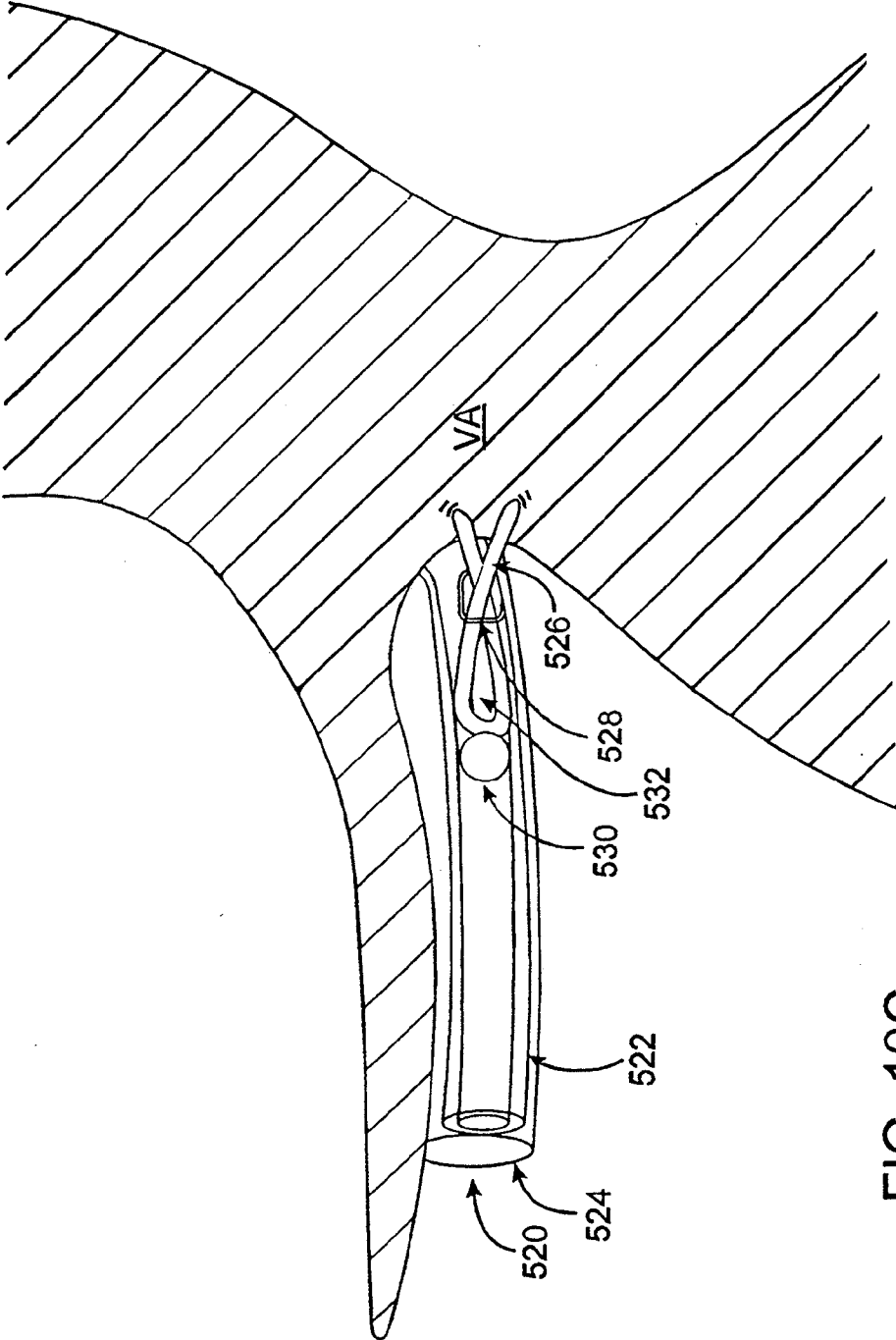

FIG. 10C

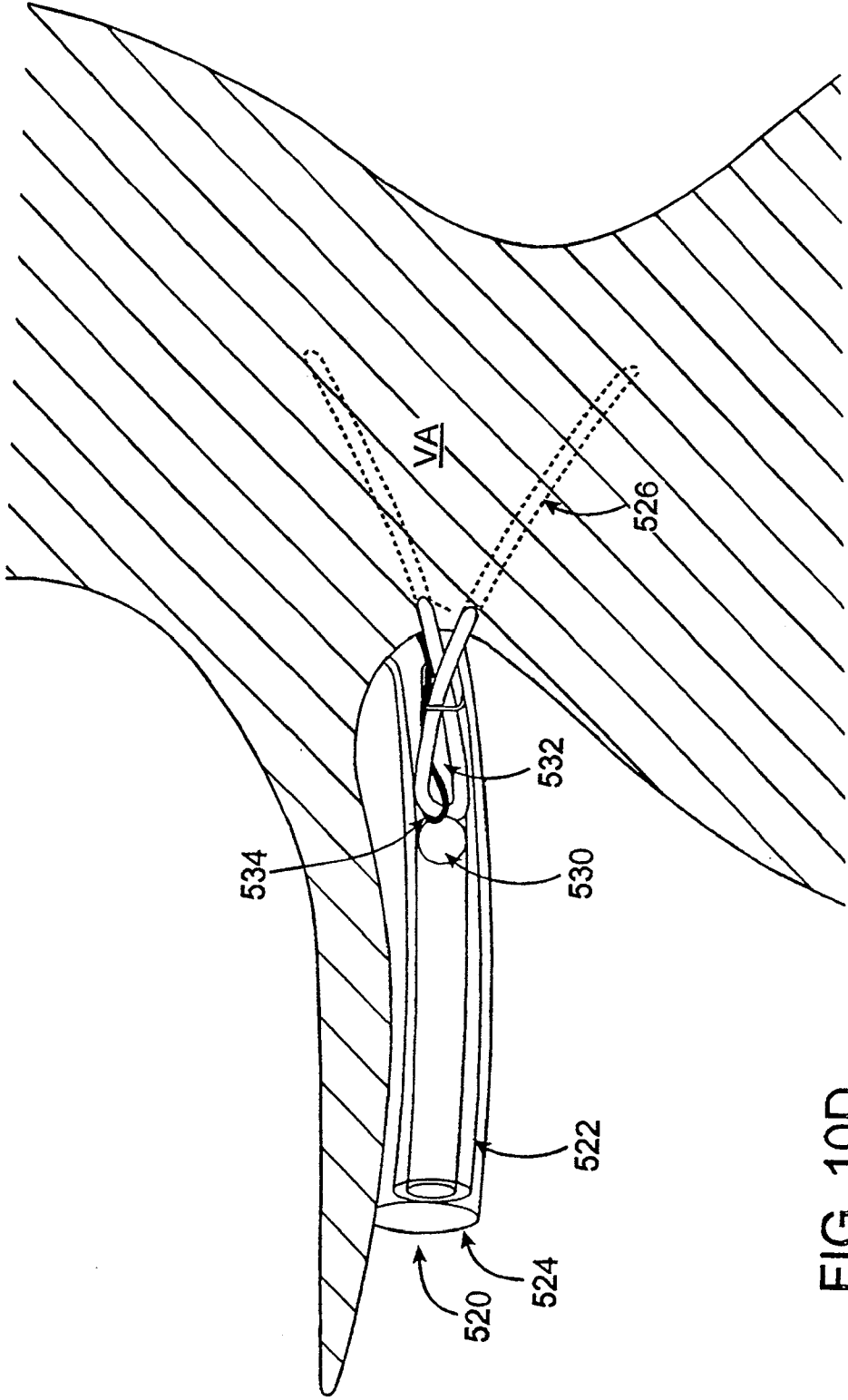

FIG. 10D

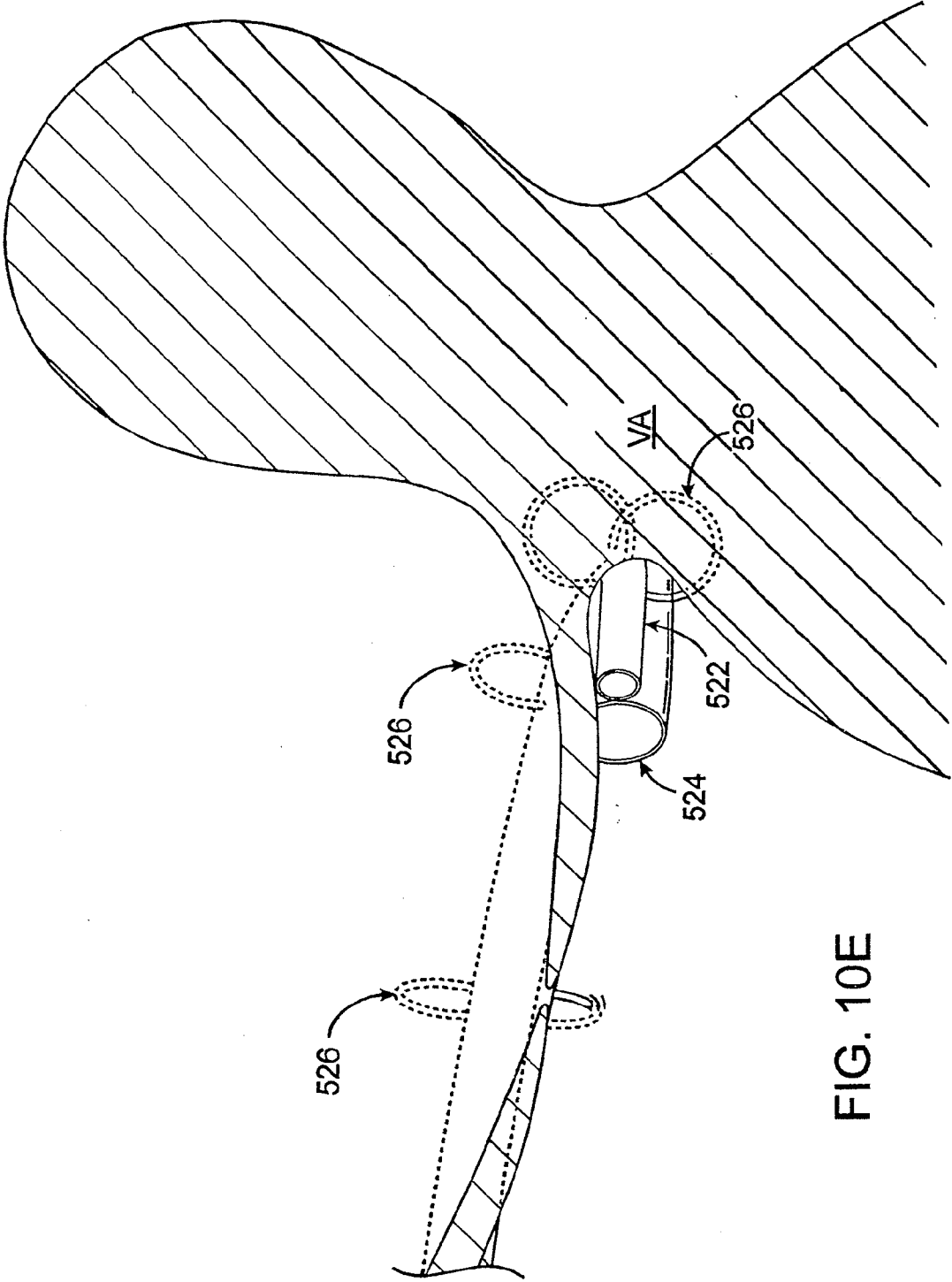

FIG. 10E

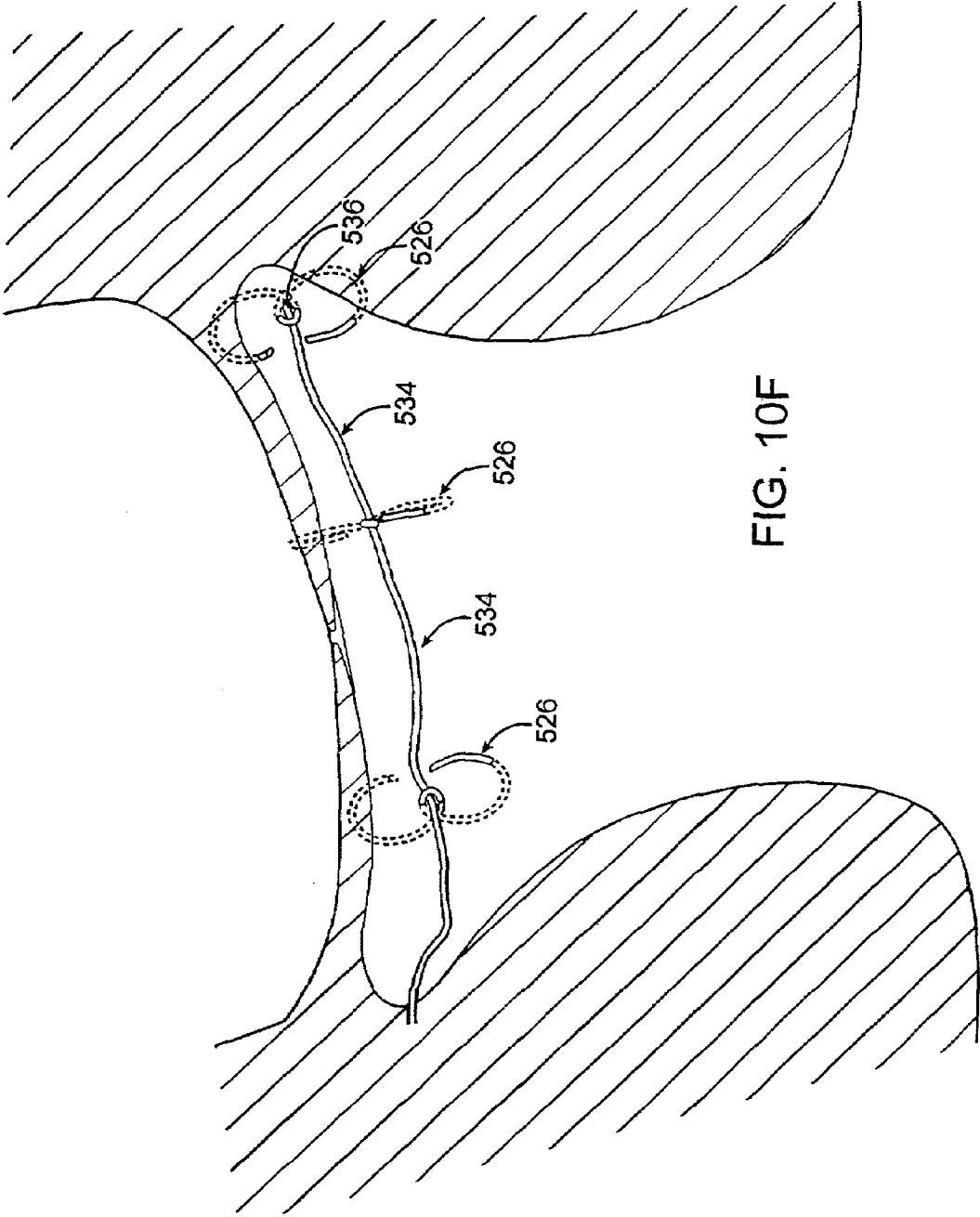

FIG. 10F

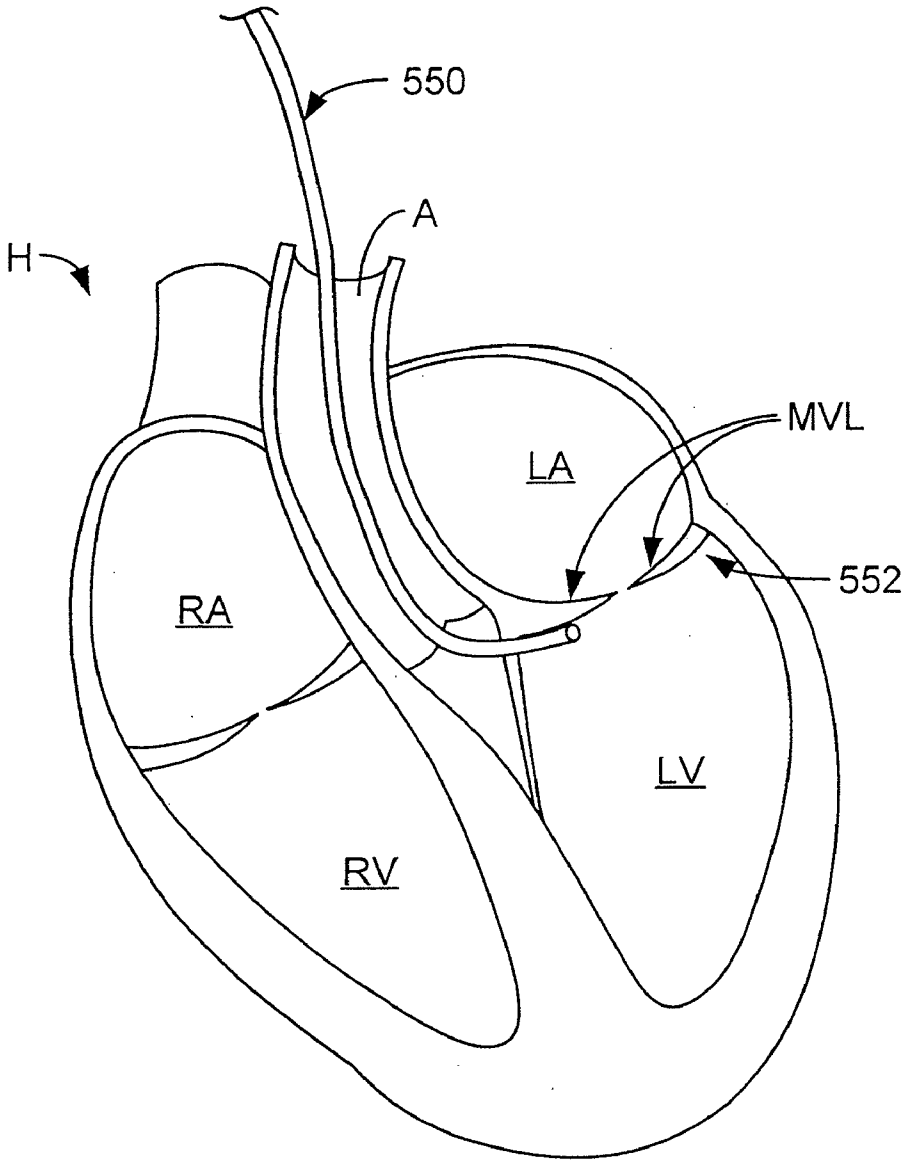

FIG. 11

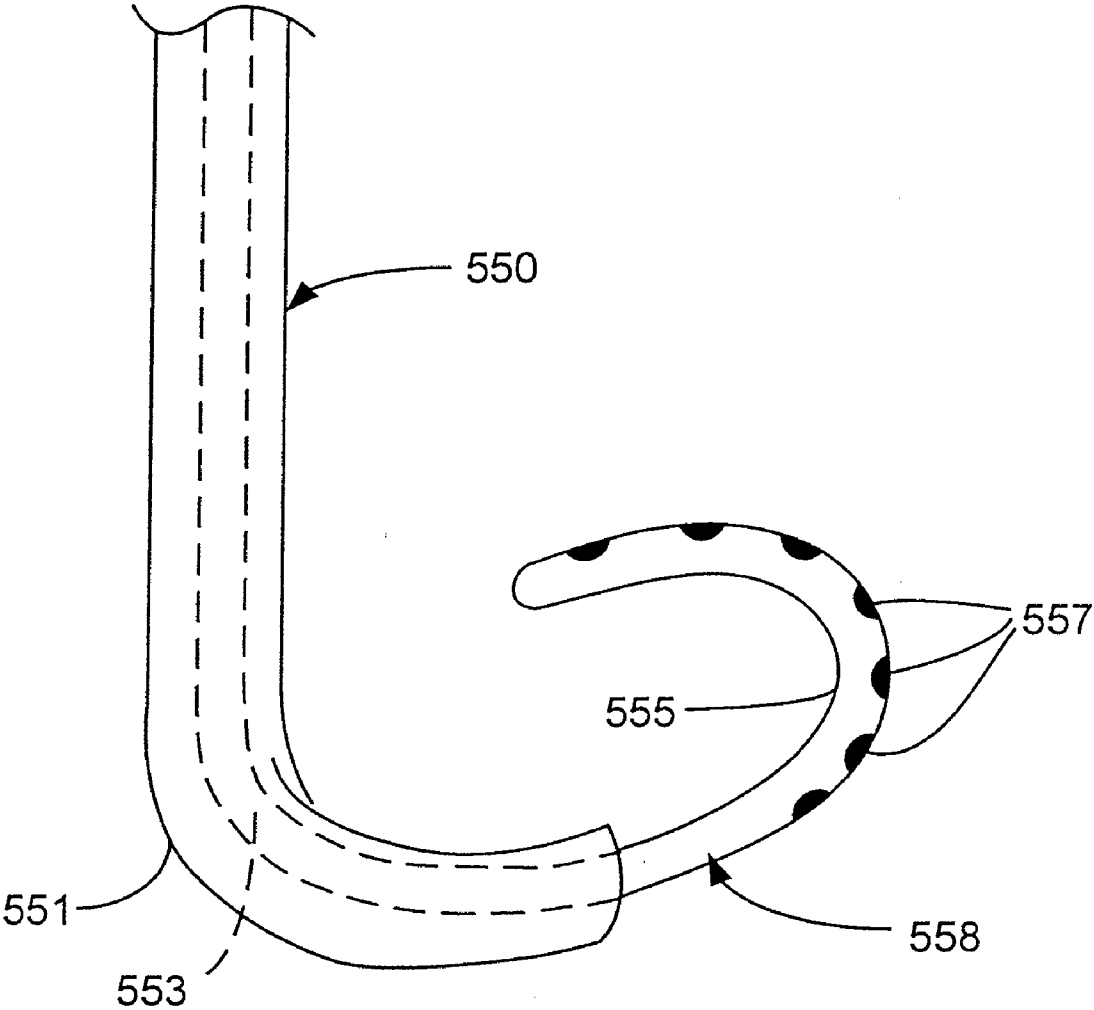

FIG. 11A

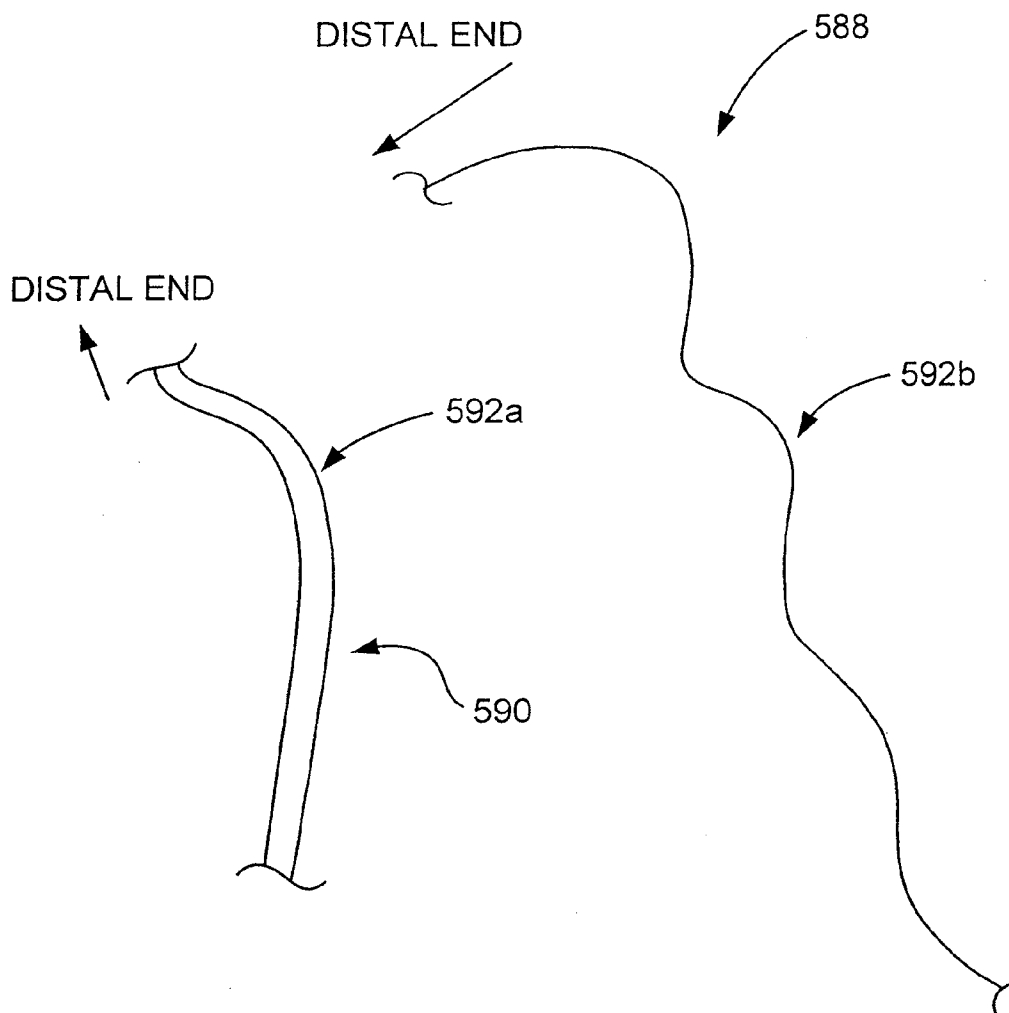

FIG. 11B

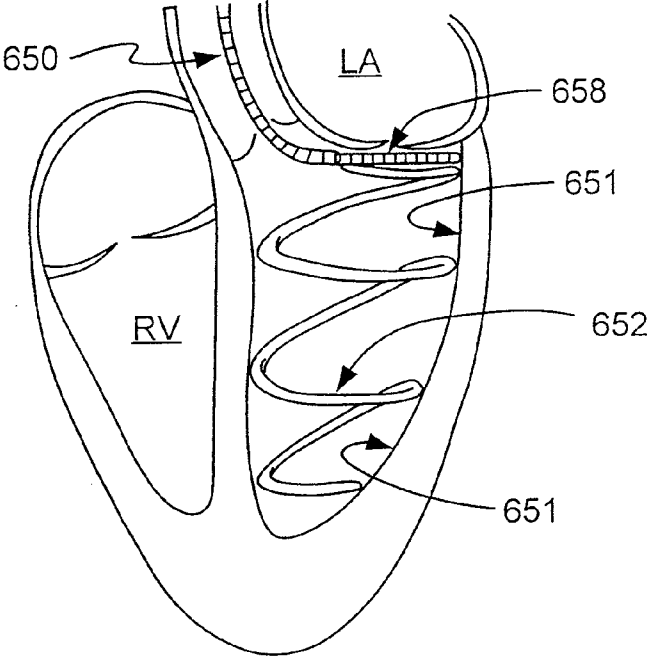

FIG. 12A

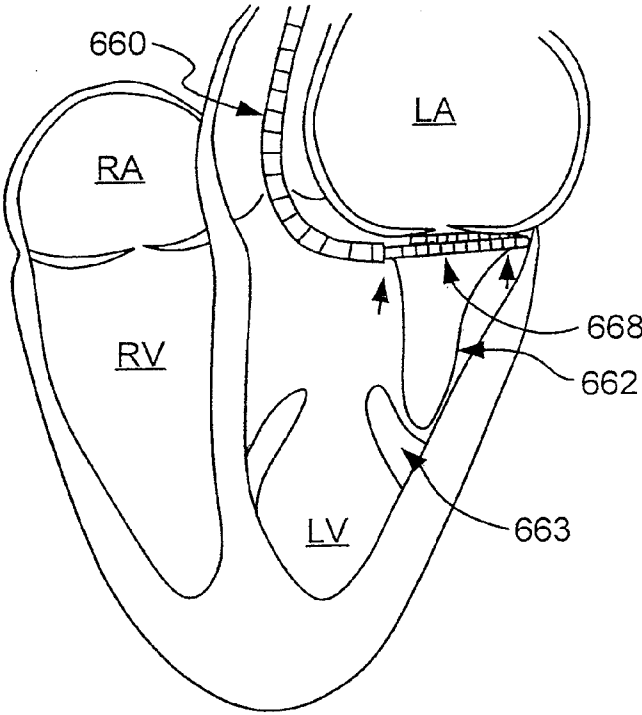

FIG. 12B

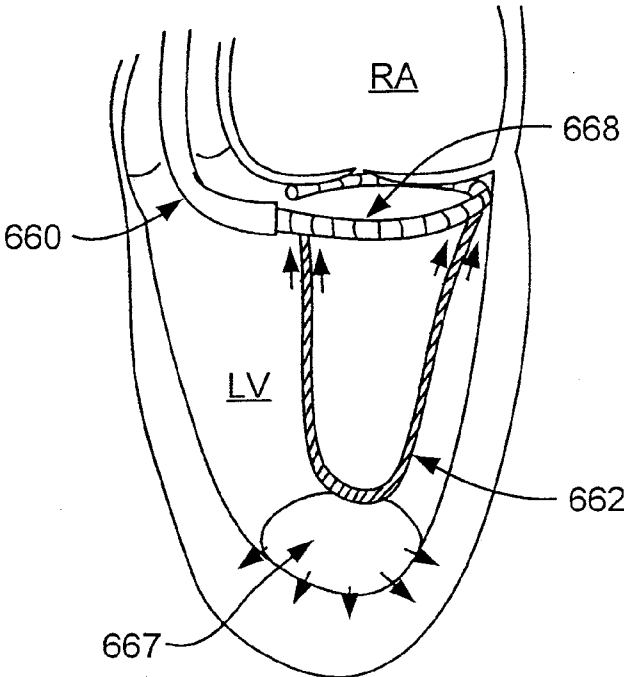

FIG. 12C

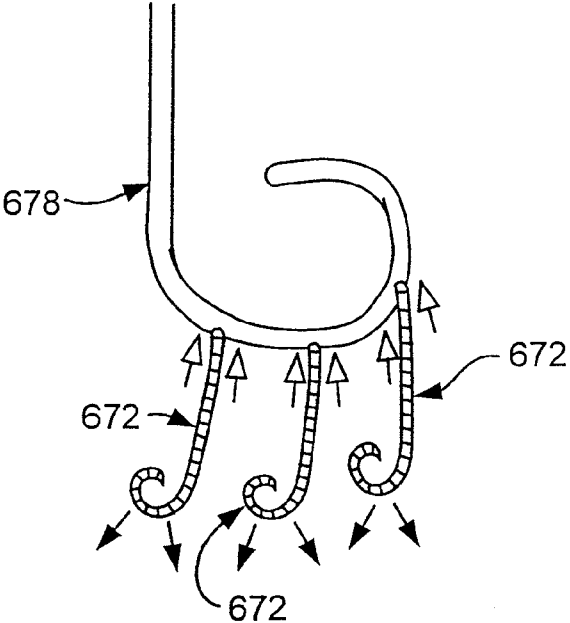

FIG. 12D

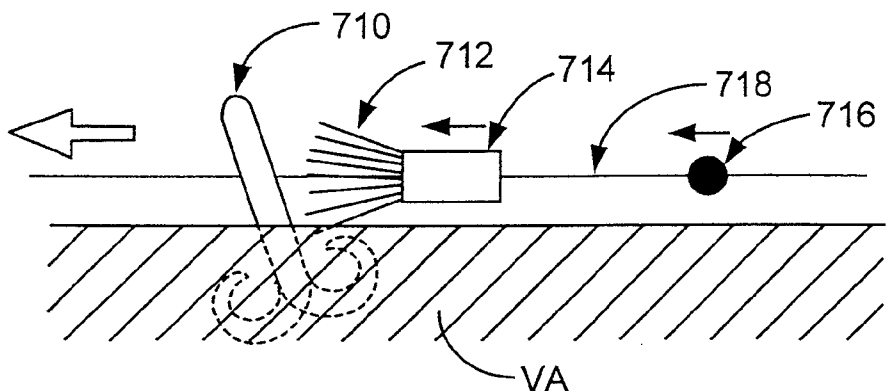

FIG. 13A

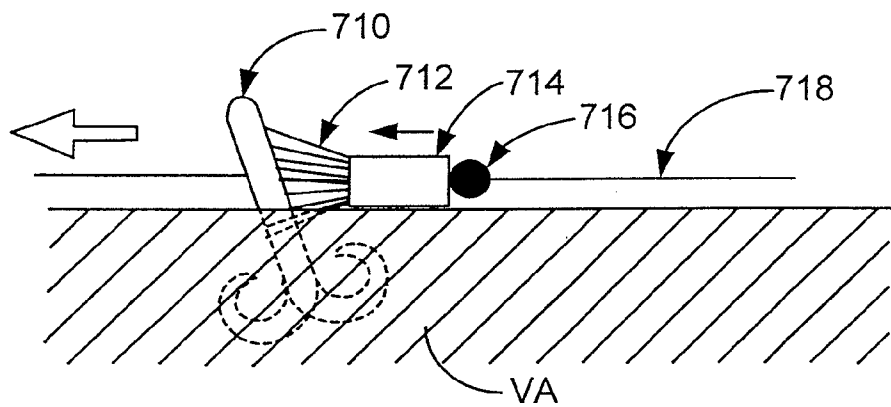

FIG. 13B

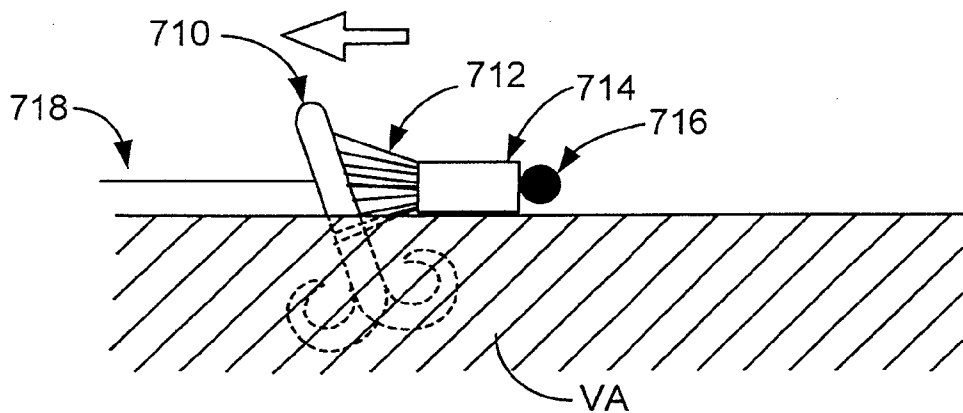

FIG. 13C

FIG. 14A

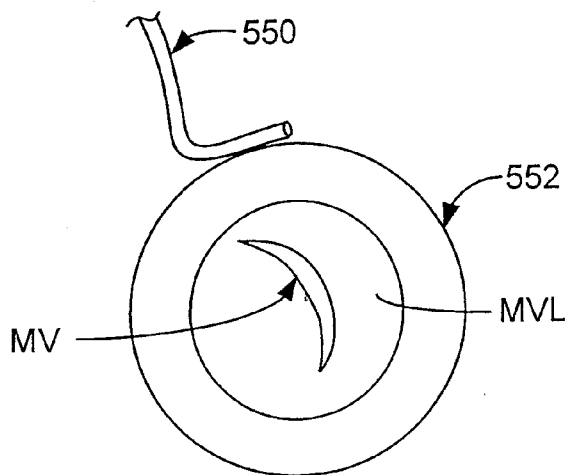

FIG. 14B

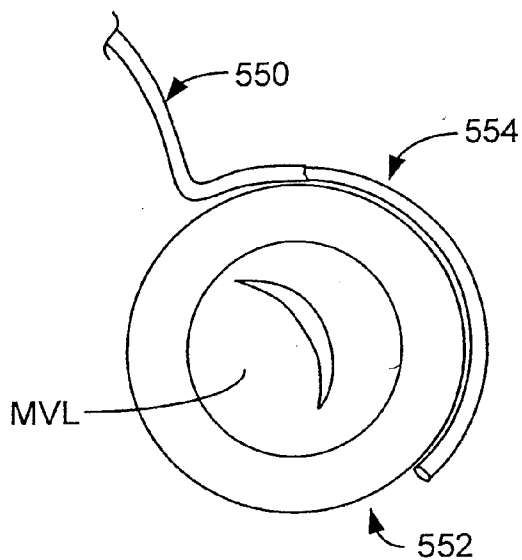

FIG. 14C

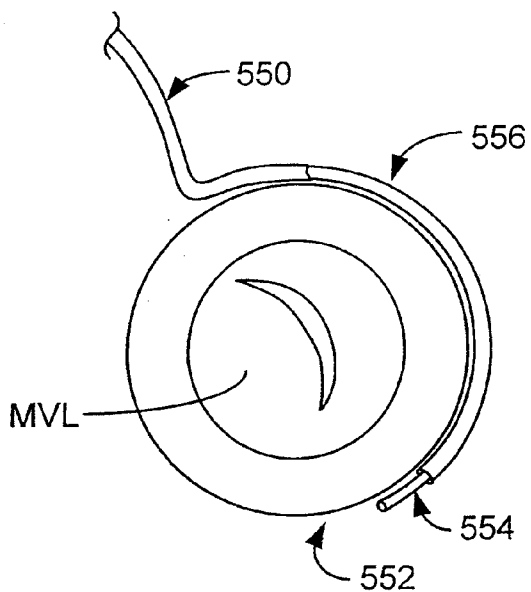

FIG. 14D

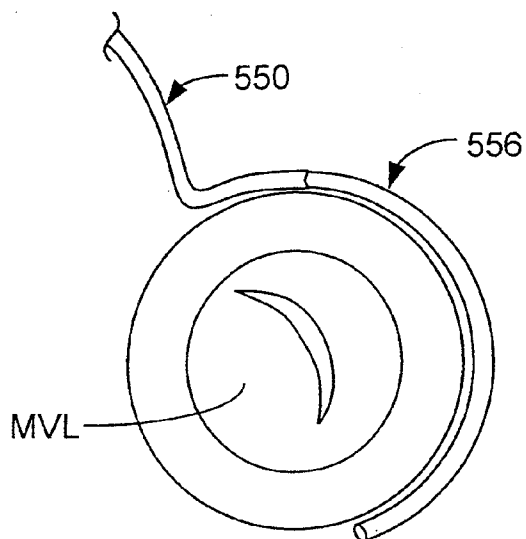

FIG. 14E

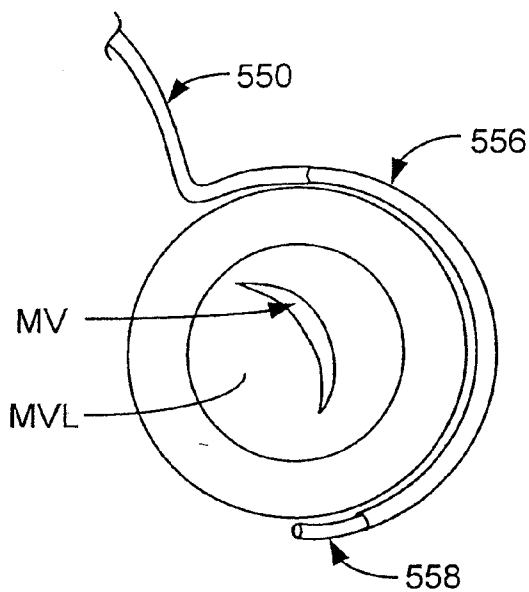
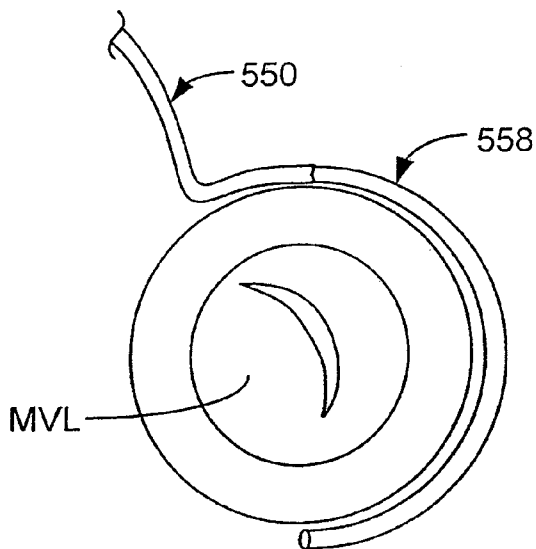

FIG. 14F



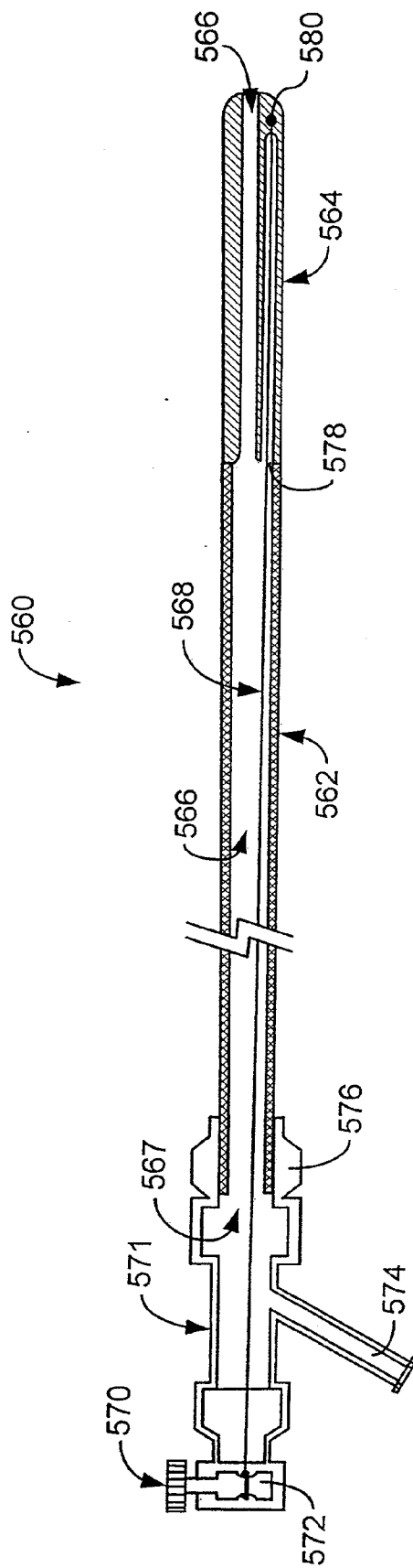

FIG. 15A

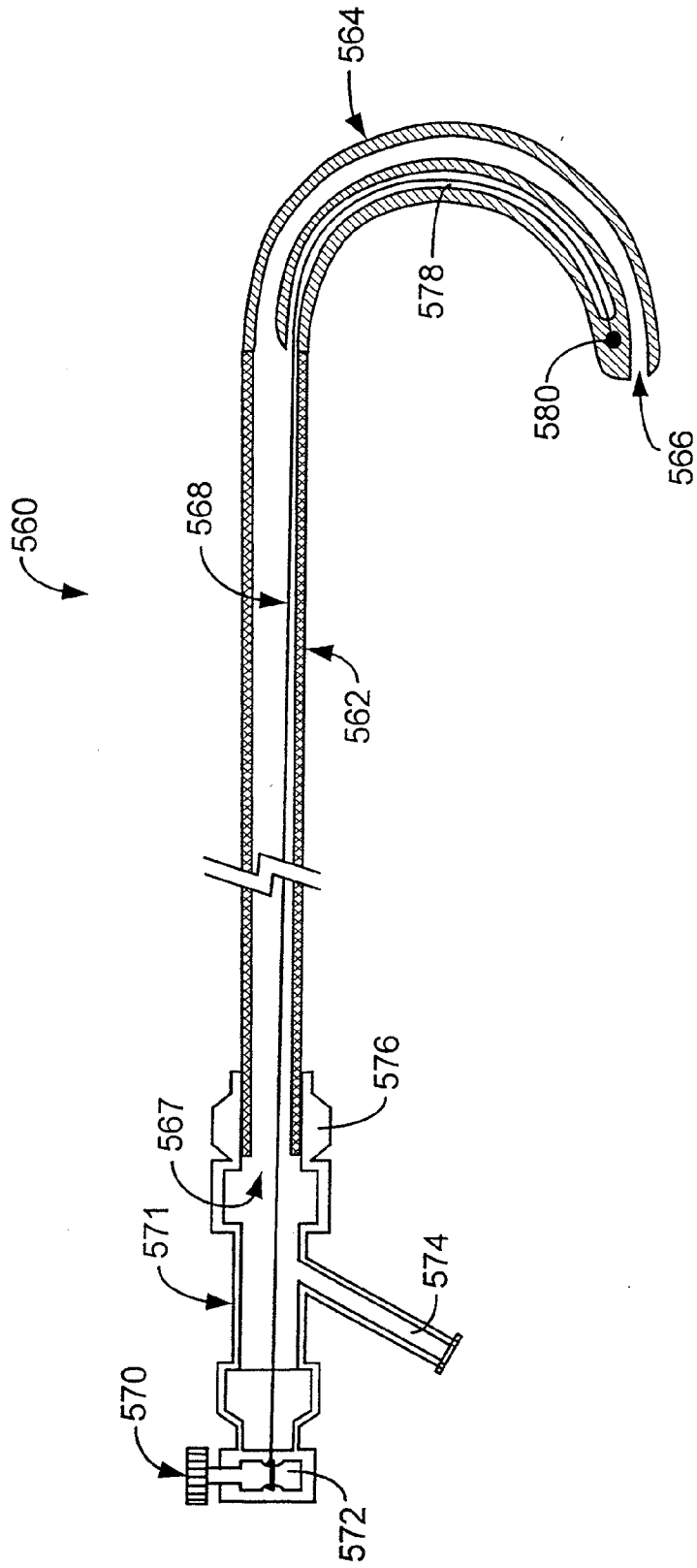

FIG. 15B

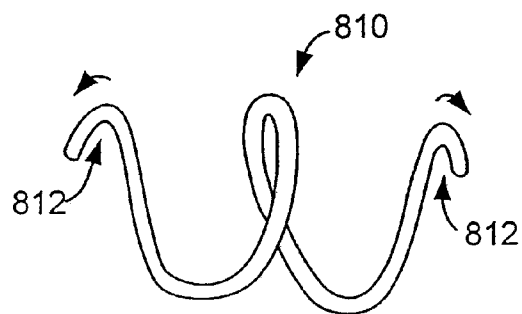

FIG. 16A

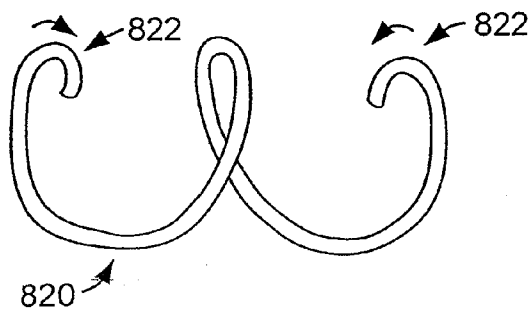

FIG. 16B

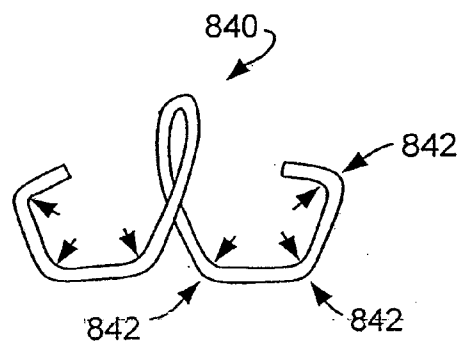

FIG. 16D

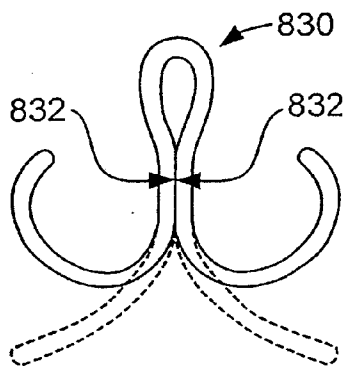

FIG. 16C

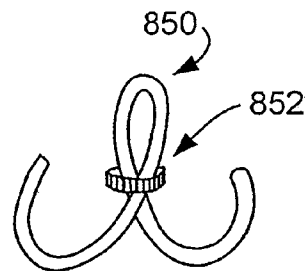

FIG. 16E

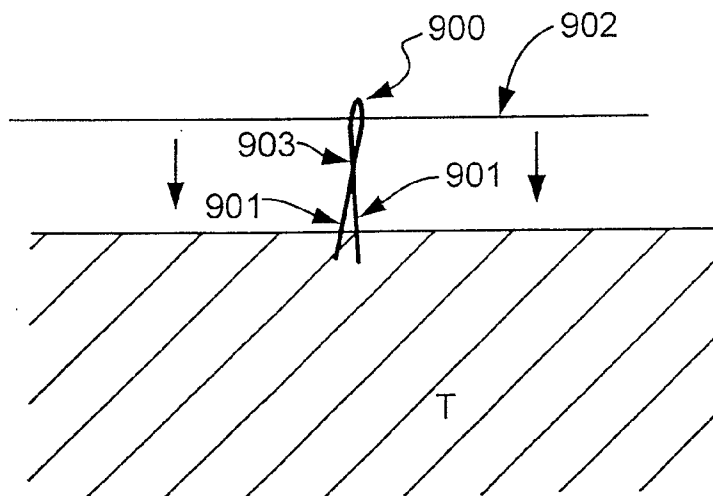

FIG. 17A

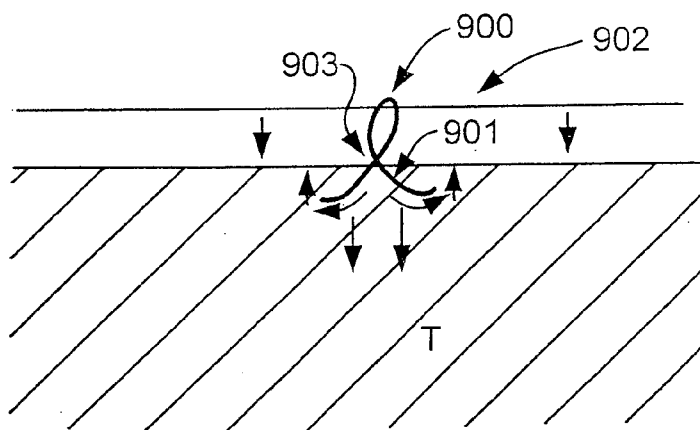

FIG. 17B

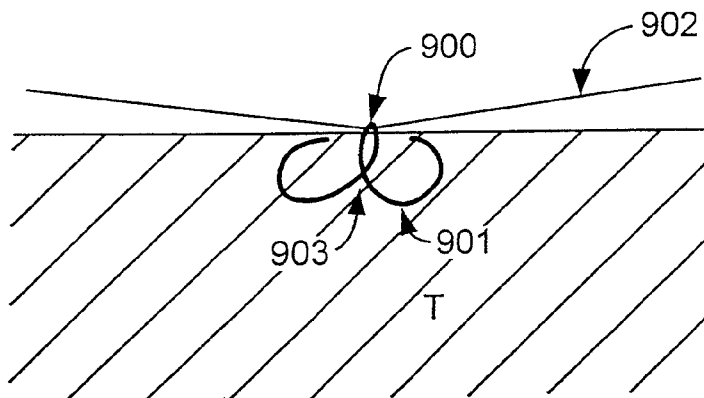

FIG. 17C

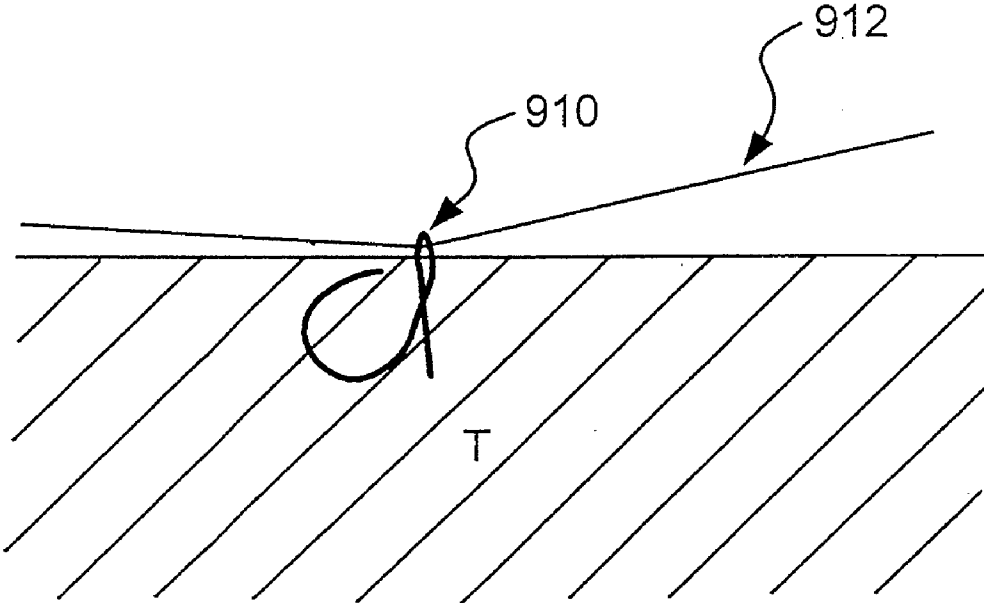

FIG. 18

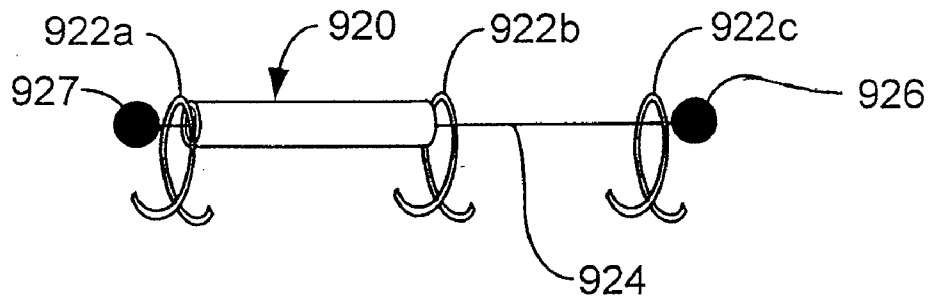

FIG. 19A

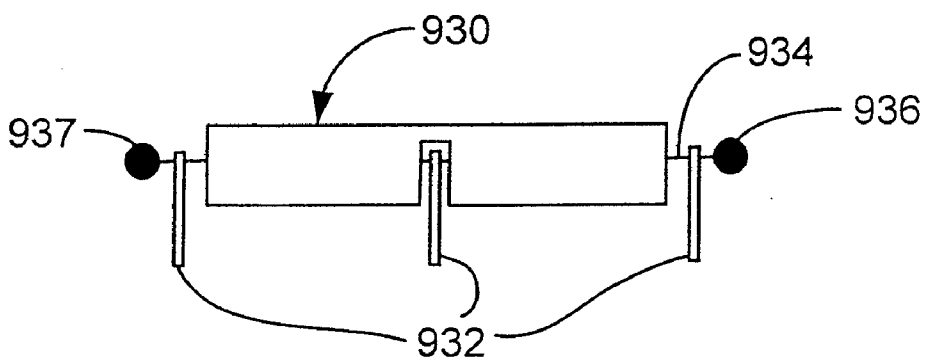

FIG. 19B

DELIVERY DEVICES AND METHODS FOR HEART VALVE REPAIR

CROSS REFERENCE TO RELATED APPLICATIONS

[0001] The present application is a continuation-in-part of U.S. patent application Ser. No. 10/792,681 (Attorney Docket No. 016886-001330US), filed on Mar. 2, 2004, which is a continuation-in-part of U.S. patent application Ser. No. 10/741,130 (Attorney Docket No. 016886-001320US), filed on Dec. 19, 2003, which is a continuation-in-part of U.S. patent application Ser. Nos. 10/656,797 (Attorney Docket No. 16886-001300US), filed on Sep. 4, 2003, and 10/461,043 (Attorney Docket No. 16886-000310US), filed on Jun. 13, 2003, the latter of which claims the benefit of U.S. Provisional Patent Application Nos. 60/388,935 (Attorney Docket No. 016886-000300US), filed on Jun. 13, 2002; 60/429,288 (Attorney Docket No. 016886-000700US), filed on Nov. 25, 2002; 60/445,890 (Attorney Docket No. 016886-000800US), filed on Feb. 6, 2003; 60/459,735 (Attorney Docket No. 16886-000900US), filed on Apr. 1, 2003; and 60/462,502 (Attorney Docket No. 016886-001100US), filed on Apr. 10, 2003. The full disclosures of all of the above-listed references are hereby incorporated by reference.

[0002] The present application is related to U.S. patent application Ser. Nos. 10/____ (Docket No. 16886-001340US); 10/____ (Attorney Docket No. 16886-001350US); 10/____ (Attorney Docket No. 16886-001360US); 10/____ (Attorney Docket No. 16886-001370US); and 10/____ (Attorney Docket No. 16886-001380US), all of which are filed concurrently herewith, and all of which are hereby fully incorporated by reference.

BACKGROUND OF THE INVENTION

[0003] 1. Field of the Invention

[0004] The present invention relates generally to medical devices and methods. More particularly, the invention relates to devices, systems and methods for enhancing cardiovascular valve repair, especially the repair of heart valves such as the mitral and tricuspid valves.

[0005] In recent years, many advances have been made to reduce the invasiveness of cardiac surgery. In an attempt to avoid open, stopped-heart procedures, which may be accompanied by high patient morbidity and mortality, many devices and methods have been developed for operating on a heart through smaller incisions, operating on a beating heart, and even performing cardiac procedures via transvascular access. Different types of cardiac procedures, such as cardiac ablation techniques for treating atrial fibrillation, stenting procedures for atherosclerosis, and valve repair procedures for treating conditions such as mitral valve regurgitation have experienced significant technological advances. In implementing many minimally invasive cardiac surgery techniques, especially beating-heart techniques, one of the most significant challenges is positioning a treatment device (or multiple devices) in a desired location in or around the heart for performing the procedure. Another challenge, once a device is positioned, is to effectively deploy a given treatment into or on the target cardiac tissue.

[0006] One type of cardiac surgery which may benefit from less invasive techniques is heart valve repair. Traditional treatment of heart valve stenosis or regurgitation, such as mitral or tricuspid regurgitation, typically involves an open-

heart surgical procedure to replace or repair the valve. Valve repair procedures typically involve annuloplasty, a set of techniques designed to restore the valve annulus shape and strengthen the annulus. Conventional annuloplasty surgery generally requires a large incision into the thorax of the patient (a thoracotomy), and sometimes a median sternotomy (cutting through the middle of the sternum). These open heart, open chest procedures routinely involve placing the patient on a cardiopulmonary bypass machine for sustained periods so that the patient's heart and lungs can be artificially stopped during the procedure. Finally, valve repair and replacement procedures are typically technically challenging and require a relatively large incision through the wall of the heart to access the valve.

[0007] Due to the highly invasive nature of open heart valve repair or replacement, many patients, such as elderly patients, patients having recently undergone other surgical procedures, patients with comorbid medical conditions, children, late-stage heart failure patients, and the like, are often considered too high-risk to undergo heart valve surgery and are relegated to progressive deterioration and cardiac enlargement. Often, such patients have no feasible alternative treatments for their heart valve conditions.

[0008] To obviate this situation, a number of devices and methods for repairing cardiac valves in a less invasive manner have been described. Some devices provide for heart valve repair through minimally invasive incisions or intravascularly, while others improve upon open heart surgical procedures on beating hearts, stopped hearts or both. As mentioned above, difficulties in performing minimally invasive intracardiac surgery include positioning a minimally invasive treatment device in a desired location for performing a procedure and effectively deploying a given treatment into or on the target cardiac tissue. In heart valve repair procedures, for example, it is often essential for a physician to secure one or more treatment devices to valve annulus tissue. Annular tissue tends to be more fibrous than surrounding muscular or valve leaflet tissue, thus providing a more suitable location for securing such treatment devices, such as anchors, to treat a heart valve. Positioning an anchor deliver device in a desired location adjacent the annular tissue may often be challenging, especially in an intravascular procedure when visualization of the location is limited.

[0009] Devices and methods that address these difficulties are described in U.S. patent application Ser. Nos. 10/792,681, 10/741,130, 10/656,797, 10/461,043, 60/388,935, 60/429,288, 60/445,890, 60/462,502 and 60/524,622, which were previously incorporated by reference. For example, these references describe devices and methods for exposing, stabilizing and/or performing a procedure on a heart valve annulus, such as a mitral valve annulus. Many of the devices and methods previously described by the inventors have been found to be highly effective, but improvements are still being sought.

[0010] Therefore, it would be beneficial to have improved methods, devices and systems for enhancing heart valve annulus treatment procedures. Ideally, such methods, devices and systems would facilitate positioning of one or more devices in a left ventricle or elsewhere for performing a procedure on a heart valve annulus, visualizing the annulus and/or the like. Additionally, such methods, devices and systems would ideally be introduced intravascularly. At least some of these objectives will be met by the present invention.

[0011] 2. Description of the Background Art

[0012] Published U.S. Application Nos. 2002/0156526, 2003/0220685, 2004/0019378, 2004/0003819, 2004/0030382 and 2004/0039442, and U.S. Pat. Nos. 6,629,534 and 6,619,291 describe catheter-based methods for performing annuloplasty. Published U.S. Application 2002/0042621 describes a heart valve annuloplasty system with constrictable plication bands which are optionally attached to a linkage strip. Published U.S. Application 2002/0087169 describes a remote controlled catheter system which can be used to deliver anchors and a tether for performing an annuloplasty procedure. Other patent publications of interest include WO01/26586; US2001/0005787; US2001/0014800; US2002/0013621; US2002/0029080; US2002/0035361; US2002/0042621; US2002/0095167; and US2003/0074012. U.S. patents of interest include U.S. Pat. No. 4,014,492; U.S. Pat. No. 4,042,979; U.S. Pat. No. 4,043,504; U.S. Pat. No. 4,055,861; U.S. Pat. No. 4,700,250; U.S. Pat. No. 5,366,479; U.S. Pat. No. 5,450,860; U.S. Pat. No. 5,571,215; U.S. Pat. No. 5,674,279; U.S. Pat. No. 5,709,695; U.S. Pat. No. 5,752,518; U.S. Pat. No. 5,848,969; U.S. Pat. No. 5,860,992; U.S. Pat. No. 5,904,651; U.S. Pat. No. 5,961,539; U.S. Pat. No. 5,972,004; U.S. Pat. No. 6,165,183; U.S. Pat. No. 6,197,017; U.S. Pat. No. 6,250,308; U.S. Pat. No. 6,260,552; U.S. Pat. No. 6,283,993; U.S. Pat. No. 6,269,819; U.S. Pat. No. 6,312,447; U.S. Pat. No. 6,332,893; and U.S. Pat. No. 6,524,338. Publications of interest include De Simone et al. (1993) *Am. J. Cardiol.* 73:721-722, and Downing et al. (2001) *Heart Surgery Forum*, Abstract 7025. All of the above cited references are hereby incorporated by reference in the present application.

BRIEF SUMMARY OF THE INVENTION

[0013] Devices, systems and methods of the present invention are generally used to facilitate transvascular, minimally invasive and other "less invasive" surgical procedures, by facilitating the delivery of treatment devices at a treatment site. "Less invasive," for the purposes of this application, means any procedure that is less invasive than traditional, large-incision, open surgical procedures. Thus, a less invasive procedure may be an open surgical procedure involving one or more relatively small incisions, a procedure performed via transvascular percutaneous access, a transvascular procedure via cut-down, a laparoscopic or other endoscopic procedure, or the like. Generally, any procedure in which a goal is to minimize or reduce invasiveness to the patient may be considered less invasive. Furthermore, although the terms "less invasive" and "minimally invasive" may sometimes be used interchangeably in this application, neither these nor terms used to describe a particular subset of surgical or other procedures should be interpreted to limit the scope of the invention. Generally, devices and methods of the invention may be used in performing or enhancing any suitable procedure.

[0014] The present application typically describes devices, systems and methods for performing heart valve repair procedures, and more specifically heart valve annuloplasty procedures such as mitral valve annuloplasty to treat mitral regurgitation. Devices and methods of the invention, however, may be used in any suitable procedure, both cardiac and non-cardiac. For example, they may be used in procedures to repair any heart valve, to repair an atrial-septal defect, to access and possibly perform a valve repair or other procedure from (or through) the coronary sinus, to place one or more pacemaker leads, to perform a cardiac ablation procedure

such as ablating around pulmonary veins to treat atrial fibrillation, and/or the like. In other embodiments, the devices and methods may be used to enhance a laparoscopic or other endoscopic procedure on any part of the body, such as the bladder, stomach, gastroesophageal junction, vasculature, gall bladder, or the like. Therefore, although the following description typically focuses on mitral valve and other heart valve repair, such description should not be interpreted to limit the scope of the invention as defined by the claims.

[0015] That being said, the present invention generally provides devices, systems and methods for enhanced treatment of a cardiac valve annulus such as a mitral valve annulus. Methods generally involve contacting an anchor delivery device with a length of a valve annulus, delivering a plurality of coupled anchors from the anchor delivery device to secure the anchors to the annulus, and drawing the anchors together to circumferentially tighten the annulus. One device generally includes an elongate catheter having a housing at or near the distal end for releasably housing a plurality of coupled anchors. The device may be positioned such that the housing abuts or is close to valve annular tissue, such as at an intersection of the left ventricular wall and one or more mitral valve leaflets of the heart. Some embodiments include self-securing anchors, which may change from undeployed to deployed configurations. Anchors may be drawn together to tighten the annulus by cinching a tether slidably coupled with the anchors and/or by a self-deforming member coupled with the anchors. Another device includes a steerable guide catheter for helping position the anchor delivery device for treating a valve annulus.

[0016] In many cases, methods of the present invention will be performed on a beating heart. Access to the beating heart may be accomplished by any available technique, including intravascular, transthoracic, and the like. Intravascular access to a heart valve may be achieved using any suitable route or method. To perform a procedure on a mitral valve, for example, in one embodiment a catheter may be advanced through a femoral artery, to the aorta, and into the left ventricle of the heart, to contact a length of the mitral valve. Alternatively, access may be gained through the venous system, to a central vein, into the right atrium of the heart, and across the interatrial septum to the left side of the heart to contact a length of the mitral valve. In either of these two types of intravascular access, the catheter will often easily be advanced, once it enters the left side of the heart, into a space defined by the left ventricular wall, one or more mitral valve leaflets, and chordae tendineae of the left ventricle. This space provides a convenient conduit for further advancement of the catheter to a desired location for performing mitral valve repair. In alternative embodiments, a catheter device may access the coronary sinus and a valve procedure may be performed directly from the sinus. Furthermore, in addition to beating heart access, methods of the present invention may be used for intravascular stopped heart access as well as stopped heart open chest procedures. Any suitable intravascular or other access method is contemplated within the scope of the invention.

[0017] In one aspect of the present invention, a device for performing a procedure on heart valve annulus includes: a flexible, elongate catheter having a proximal portion and a shaped distal portion, the distal portion having at least one aperture for allowing passage of tissue anchors; multiple tissue anchors releasably housed in the shaped distal portion; at least one cinchable tether slidably coupled with the tissue

anchors; and at least one anchor delivery member housed in the distal portion for delivering the anchors out of the at least one aperture to engage tissue of the valve annulus.

[0018] In some embodiments, the shaped distal portion comprises at least a first curve. The first curve may have any suitable shape, radius of curvature or the like, such as in one embodiment where the first curve has a radius of curvature between 0.5 inches and 1.5 inches. In some embodiments, the shaped distal portion further comprises a second curve. The first and second curves may be adapted to orient a distal-most portion of the catheter at an angle of between 45° and 90°, relative to the proximal portion of the catheter immediately adjacent the distal portion. In some embodiments, the second curve has a radius of curvature approximating a radius of curvature of the heart valve. In an alternative embodiment, the second curve has a radius of curvature greater than a radius of curvature of the heart valve, wherein the greater radius of curvature causes the distal portion to press outward against the valve annulus. Optionally, at least one of the first and second curves may have the same shape as a corresponding curve in a guide catheter used for delivering the elongate catheter into contact with the valve annulus. For example, first and second curves in the elongate catheter may correspond to first and second corresponding curves in the guide catheter. In such embodiments, the elongate catheter, when advanced through the guide catheter, is oriented such that the at least one aperture contacts the valve annulus tissue.

[0019] Some embodiments of the device further include at least one stabilizing member coupled with the elongate catheter for maintaining the distal portion in contact with valve annulus tissue. In some embodiments, for example, the stabilizing member comprises a spiral-shaped member extending from the distal portion to press against heart wall tissue, thus urging the distal portion against the annulus tissue. Optionally, a distal end of the spiral-shaped member may be adapted to engage and press against a junction of one or more papillary muscles and heart wall tissue. In other embodiments, the stabilizing member comprises an arch-shaped shape-memory or spring-loaded member extending from the distal portion to press against heart wall tissue, thus urging the distal portion against the annulus tissue. In one embodiment, a portion of the arch-shaped member is adapted to engage and press against a junction of one or more papillary muscles and heart wall tissue. The device may optionally further include an expandable member coupled with the arch-shaped member for inflating to further press against the heart wall tissue. In other embodiment, the stabilizing member comprises multiple springs extending from the distal portion to press against heart wall tissue, thus urging the distal portion against the annulus tissue. Alternatively, the stabilizing member may include a curved balloon coupled with the distal portion of the catheter, the curved balloon having a greater radius of curvature than a radius of curvature of the valve annulus. Inflating the balloon thus urges the distal portion against the annulus tissue.

[0020] In some embodiments, the device further includes at least one termination member for enhancing attachment of a terminal tissue anchor to the heart valve annulus. In some embodiment, the termination member is slidably couplable with the tether. In some embodiments, the termination member is coupled with the tether via a termination catheter device. The termination member may include, for example, at least one deployable tissue attachment member deployable from a retracted configuration for delivery to an expanded

configuration for attachment to the valve annulus tissue. The tissue attachment members may include a plurality of members, such as but not limited to barbs, points, needles, hooks, tines, rakes, wires, teeth and/or the like. In some embodiments, the tissue attachment members comprise a shape-memory or super-elastic material. The tissue attachment members may, for example, be disposed circumferentially about a cylindrical member adapted to slide over the tether. Alternatively, the tissue attachment members may be disposed along a portion of a cylindrical member adapted to slide over the tether.

[0021] In some embodiments, the tissue attachment members further include a pusher for pushing the tissue attachment member out of the elongate catheter and into the valve annulus tissue. In some embodiments, the tissue attachment members are adapted to engage the terminal tissue anchor. In one embodiment, the tissue attachment members are adapted to enter into the valve annulus tissue in a direction from the terminal tissue anchor toward the other tissue anchors. Optionally, the tissue attachment members may further include a fiber, matrix, textile or mesh disposed on at least a portion of the tissue attachment member for enhancing tissue in-growth over the tissue attachment member.

[0022] In some embodiments, each of the tissue anchors comprises at least one tissue engagement feature for preventing the anchors from being pulled out of the valve annulus tissue when the tether is cinched. For example, the tissue engagement feature(s) may include a barb on each end of each tissue anchor. Such a barb may face inward toward a center of the anchor or outward away from the center. In another embodiment, the tissue engagement features comprise a plurality of bends in each anchor. Optionally, each of the tissue anchors may include at least one support member for preventing the anchors from being pulled out of the valve annulus tissue when the tether is cinched. For example, the support member may comprise an attachment point of one arm of each anchor to another arm of each anchor, the attachment point positioned adjacent an eyelet of the anchor. Optionally, a constraining member may be disposed over the attachment point to provide further support. The constraining member may include, for example, a band, tie, sleeve, belt or the like. In some embodiments of the device, each of the tissue anchors comprises at least one tissue adhesion feature adapted to enhance attachment of the tissue anchors to the valve annulus tissue. For example, the tissue adhesion feature may comprise one or more materials disposed over at least part of each anchor, the material(s) selected to promote encapsulation of the anchors within the valve annulus tissue. In one embodiment, the anchor delivery member comprises an anchor contacting member for contacting and urging the anchors out of the at least one aperture and a pull cord coupled with the anchor contacting member for applying force to the anchor contacting member to contact and urge the anchors.

[0023] In another aspect of the invention, a device for constricting a valve annulus in a heart includes a plurality of slidably coupled tissue anchors, each anchor including at least one tissue attachment feature for enhancing attachment of the anchor to valve annulus tissue, and at least one cinchable tether slidably coupled with at least some of the tissue anchors and fixedly attached to at least a first of the anchors. The tissue attachment features may comprise any of a number of suitable features. In one embodiment, for example, a surface feature is included along at least a portion of each anchor, such as a porous, textured or coated surface. In other embodi-

ments, the attachment feature comprises at least one circular or hooked portion of each anchor having a small radius of curvature. Alternatively or additionally, the attachment feature may comprise a barb at each end of each anchor.

[0024] In another aspect of the invention, a method of constricting a valve annulus in a heart involves: contacting a shaped distal portion of an anchor delivery catheter device with a length of the valve annulus; delivering a plurality of slidably coupled anchors from the anchor delivery device to secure the anchors to the annulus; drawing the anchors together to circumferentially tighten the valve annulus; and promoting attachment of the anchors to valve annulus tissue to help secure the anchors to the tissue over time. In some embodiments, contacting the distal portion comprises advancing the catheter device through a shaped introducer device, a shape of the shaped distal portion corresponding to a shape of the introducer device. In such embodiments, advancing the catheter device through the introducer devices may orient one or more apertures on the catheter device with the valve annulus tissue, so that the anchors are delivered into the tissue.

[0025] In some embodiments, the method includes stabilizing the distal portion of the catheter device against the valve annulus tissue. For example, stabilizing may involve deploying at least one stabilizing member from the distal portion of the catheter device to contact heart wall tissue of the heart. Optionally, the method may further include securing at least one termination member to the valve annulus tissue, to help maintain attachment of the coupled anchors to the tissue. In one embodiment, for example, securing the termination member involves sliding the termination member along a tether slidably coupled with the anchors and deploying tissue engagement means on the termination member from an unexpanded to an expanded configuration to engage the valve tissue. Some embodiments further include engaging the tissue engagement means with at least a terminal anchor of the plurality of anchors.

[0026] Promoting attachment of the anchors to the tissue may be achieved via any of a number of different methods in various embodiments. For example, in one embodiment promoting anchor attachment comprises contacting at least one surface feature of each anchor with the tissue. The surface features may include one or more of those described above, such as a porous surface, a roughened surface, a coated surface and/or an abrasive surface.

[0027] In another aspect of the present invention, a method for contacting a shaped distal portion of an anchor delivery catheter with a mitral valve annulus of a heart involves advancing the anchor delivery catheter through a shaped guide catheter into the left ventricle to contact the mitral valve. In this method, at least one bend in the shaped distal portion of the delivery device has approximately the same radius of curvature at least one corresponding bend in the guide catheter, so that advancing the distal portion of the delivery catheter through the at least one corresponding bend positions one or more anchor delivery apertures of the anchor delivery catheter in contact with the mitral valve annulus.

[0028] These and other aspects and embodiments are described more fully below with reference to the drawing figures.

BRIEF DESCRIPTION OF THE DRAWINGS

[0029] FIG. 1 is a cross-sectional view of a heart with a flexible anchor delivery device being positioned for treatment of a mitral valve annulus, according to one embodiment of the present invention;

[0030] FIGS. 2A and 2B are cross-sectional views of a portion of a heart, schematically showing positioning of a flexible device for treatment of a mitral valve annulus, according to one embodiment of the present invention;

[0031] FIGS. 2C and 2D are cross-sectional views of a portion of a heart, showing positioning of a flexible anchor delivery device for treatment of a mitral valve annulus, according to one embodiment of the present invention;

[0032] FIG. 3 is a perspective view of a distal portion of an anchor delivery device, according to one embodiment of the invention;

[0033] FIG. 4 is a perspective view of a segment of a distal portion of an anchor delivery device, with anchors in an undeployed shape and position;

[0034] FIG. 5 is a different perspective view of the segment of the device shown in FIG. 4;

[0035] FIG. 6 is a perspective view of a segment of a distal portion of an anchor delivery device, with anchors in a deployed shape and position;

[0036] FIGS. 7A-7E are cross-sectional views of an anchor delivery device, illustrating a method for delivering anchors to valve annulus tissue, according to one embodiment of the invention;

[0037] FIGS. 8A and 8B are top-views of a plurality of anchors coupled to a self-deforming coupling member or "backbone," with the backbone shown in an undeployed shape and a deployed shape;

[0038] FIGS. 9A-9C are various perspective views of a distal portion of a flexible anchor delivery device according to one embodiment of the present invention;

[0039] FIGS. 10A-10F demonstrate a method for applying anchors to a valve annulus and cinching the anchors to tighten the annulus, using an anchor delivery device according to an embodiment of the invention;

[0040] FIG. 11 shows a heart in cross-section with a guide catheter device advanced through the aorta into the left ventricle according to an embodiment of the invention;

[0041] FIG. 11A shows a distal end of an anchor delivery device passing through a guide catheter according to an embodiment of the invention;

[0042] FIG. 11B shows middle portions of an anchor delivery device and a guide catheter having corresponding orientation portions according to an embodiment of the invention;

[0043] FIGS. 12A-12D show various embodiments of support members for supporting an anchor delivery device against a valve annulus;

[0044] FIGS. 13A-13C show a device and method for facilitating termination and load distribution of a series of anchors according to one embodiment of the invention;

[0045] FIGS. 14A-14F demonstrate a method for advancing an anchor delivery device to a position for treating a heart valve according to an embodiment of the invention;

[0046] FIGS. 15A and 15B are side cross-sectional views of a guide catheter device for facilitating positioning of an anchor delivery device according to an embodiment of the invention;

[0047] FIGS. 16A-16E show improved tissue anchors according to various embodiments of the present invention;

[0048] FIGS. 17A-17C show a self-forming anchor attaching to tissue of a valve annulus according to one embodiment of the present invention;

[0049] FIG. 18 shows a self-forming anchor attaching to tissue of a valve annulus according to another embodiment of the present invention;

[0050] FIG. 19A shows an anchor device having a sleeve between two adjacent anchors according to one embodiment of the invention; and

[0051] FIG. 19B shows an anchor device having a sleeve between three anchors according to one embodiment of the invention.

DETAILED DESCRIPTION OF THE INVENTION

[0052] Devices, systems and methods of the present invention are generally used to facilitate transvascular, minimally invasive and other “less invasive” surgical procedures, by facilitating the delivery of treatment devices at a treatment site. Although the following description focuses on use of devices and methods of the invention for mitral valve repair, the devices and methods may be used in any suitable procedure, both cardiac and non-cardiac. When used for treatment of a cardiac valve annulus, the inventive methods generally involve contacting an anchor delivery device with a length of the valve annulus, delivering a plurality of coupled anchors from the anchor delivery device, and drawing the anchors together to tighten the annulus. Devices include an elongate catheter having a housing at or near the distal end for releasably housing a plurality of coupled anchors, as well as delivery devices for facilitating advancement and/or positioning of an anchor delivery device. Devices may be positioned such that the housing abuts or is close to valve annular tissue, such as in a location within the left ventricle defined by the left ventricular wall, a mitral valve leaflet and chordae tendineae. Self-securing anchors having any of a number of different configurations may be used in some embodiments. Additional devices include delivery devices for facilitating delivery and/or placement of an anchor delivery device at a treatment site.

[0053] In many cases, methods of the present invention will be performed on a beating heart. Access to the beating heart may be accomplished by any available technique, including intravascular, transthoracic, and the like. In addition to beating heart access, the methods of the present invention may be used for intravascular stopped heart access as well as stopped heart open chest procedures.

[0054] Referring now to FIG. 1, a heart H is shown in cross section, with an elongate anchor delivery device 100 introduced within the heart H. Generally, delivery device 100 comprises an elongate body with a distal portion 102 configured to deliver anchors to a heart valve annulus. (In FIGS. 1, 2A and 2B, distal portion 102 is shown diagrammatically without anchors or anchor-delivery mechanism to enhance clarity of the figures.) In some embodiments, the elongate body comprises a rigid shaft, while in other embodiments it comprises a flexible catheter, so that distal portion 102 may be positioned in the heart H and under one or more valve leaflets to engage a valve annulus via a transvascular approach. Transvascular access may be gained, for example, through the internal jugular vein (not shown) to the superior vena cava SVC to the right atrium RA, across the interatrial septum to the left atrium LA, and then under one or more mitral valve leaflets MVL to a position within the left ventricle (LV) under the valve annulus (not shown). Alternatively, access to the heart may be achieved via the femoral vein and the inferior vena cava. In other embodiments, access may be gained via the coronary sinus (not shown) and through the atrial wall into the left atrium. In still other embodiments, access may be achieved via a femoral artery and the aorta, into the left ventricle, and under the mitral valve. This access route will be

described in further detail below. Any other suitable access route is also contemplated within the scope of the present invention.

[0055] In other embodiments, access to the heart H may be transthoracic, with delivery device 100 being introduced into the heart via an incision or port on the heart wall. Even open heart surgical procedures may benefit from methods and devices of the invention. Furthermore, some embodiments may be used to enhance procedures on the tricuspid valve annulus, adjacent the tricuspid valve leaflets TVL, or any other cardiac or vascular valve. Therefore, although the following description typically focuses on minimally invasive or less invasive mitral valve repair for treating mitral regurgitation, the invention is in no way limited to that use.

[0056] With reference now to FIGS. 2A and 2B, a method for positioning delivery device 100 for treating a mitral valve annulus VA is depicted diagrammatically in a cross-sectional view. First, as in FIG. 2A, distal portion 102 is positioned in a desired location under a mitral valve leaflet L and adjacent a ventricular wall VW. (Again, distal portion 102 is shown without anchors or anchor-delivery mechanism for demonstrative purposes.) The valve annulus VA generally comprises an area of heart wall tissue at the junction of the ventricular wall VW and the atrial wall AW that is relatively fibrous and, thus, significantly stronger than leaflet tissue and other heart wall tissue.

[0057] Distal portion 102 may be advanced into position under the valve annulus by any suitable technique, some of which are described below in further detail. Generally, distal portion 102 may be used to deliver anchors to the valve annulus, to stabilize and/or expose the annulus, or both. In one embodiment, using a delivery device having a flexible elongate body as shown in FIG. 1, a flexible distal portion 102 may be passed from the right atrium RA through the interatrial septum in the area of the foramen ovale (not shown—behind the aorta A), into the left atrium LA and thus the left ventricle LV. Alternatively, flexible distal portion 102 may be advanced through the aorta A and into the left ventricle LV, for example using access through a femoral artery. Oftentimes, distal portion 102 will then naturally travel, upon further advancement, under the posterior valve leaflet L into a space defined above a subvalvular space 104 roughly defined for the purposes of this application as a space bordered by the inner surface of the left ventricular wall VW, the inferior surface of mitral valve leaflets L, and chordae tendineae CT connected to the ventricular wall VW and the leaflet L. It has been found that a flexible anchor delivery catheter, such as the delivery devices of the present invention, when passed under the mitral valve via an intravascular approach, often enters subvalvular space 104 relatively easily and may be advanced along space 104 either partially or completely around the circumference of the valve. Once in space 104, distal portion 102 may be conveniently positioned at the intersection of the valve leaflet (s) and the ventricular wall VW, which intersection is immediately adjacent or very near to the valve annulus VA, as shown in FIG. 2A. These are but examples of possible access routes of an anchor delivery device to a valve annulus, and any other access routes may be used.

[0058] In some embodiments, distal portion 102 includes a shape-changing portion which enables distal portion 102 to conform to the shape of the valve annulus VA. The catheter may be introduced through the vasculature with the shape-changing distal portion in a generally straight, flexible configuration. Once it is in place beneath the leaflet at the inter-

section between the leaflet and the interior ventricular wall, the shape of distal portion 102 is changed to conform to the annulus and usually the shape is “locked” to provide sufficient stiffness or rigidity to permit the application of force from distal portion 102 to the annulus. Shaping and optionally locking distal portion 102 may be accomplished in any of a number of ways. For example, in some embodiments, a shape-changing portion may be sectioned, notched, slotted or segmented and one of more tensioning members such as tensioning cords, wires or other tensioning devices coupled with the shape-changing portion may be used to shape and rigidify distal portion 102. A segmented distal portion, for example, may include multiple segments coupled with two tensioning members, each providing a different direction of articulation to the distal portion. A first bend may be created by tensioning a first member to give the distal portion a C-shape or similar shape to conform to the valve annulus, while a second bend may be created by tensioning a second member to articulate the C-shaped member upwards against the annulus. In another embodiment, a shaped expandable member, such as a balloon, may be coupled with distal portion 102 to provide for shape changing/deforming. In various embodiments, any configurations and combinations may be used to give distal portion 102 a desired shape.

[0059] In transthoracic and other embodiments, distal portion 102 may be shaped, and the method may simply involve introducing distal portion 102 under the valve leaflets. The shaped distal portion 102 may be rigid or formed from any suitable super-elastic or shape memory material, such as nitinol, spring stainless steel, or the like.

[0060] In addition to delivering anchors to the valve annulus VA, delivery device 100 (and specifically distal portion 102) may be used to stabilize and/or expose the valve annulus VA. Such stabilization and exposure are described fully in U.S. patent application Ser. No. 10/656,797, which was previously incorporated by reference. For example, once distal portion 102 is positioned under the annulus, force may be applied to distal portion 102 to stabilize the valve annulus VA, as shown in FIG. 2B. Such force may be directed in any suitable direction to expose, position and/or stabilize the annulus. For example, upward and lateral force is shown in FIG. 2B by the solid-headed arrow drawn from the center of distal portion 102. In other cases, only upward, only lateral, or any other suitable force(s) may be applied. With application of force to distal portion 102, the valve annulus VA is caused to rise or project outwardly, thus exposing the annulus for easier viewing and access. The applied force may also stabilize the valve annulus VA, also facilitating surgical procedures and visualization.

[0061] Some embodiments may include a stabilization component as well as an anchor delivery component. For example, some embodiments may include two flexible members, one for contacting the atrial side of a valve annulus and the other for contacting the ventricular side. In some embodiments, such flexible members may be used to “clamp” the annulus between them. One of such members may be an anchor delivery member and the other may be a stabilization member, for example. Any combination and configuration of stabilization and/or anchor delivery members is contemplated.

[0062] Referring now to FIGS. 2C and 2D, an anchor delivery device 108 is shown delivering an anchor 110 to a valve annulus VA. Of course, these are again representational figures and are not drawn to scale. Anchor 110 is shown first

housed within delivery device 108 (FIG. 2C) and then delivered to the annulus VA (FIG. 2D). As is shown, in one embodiment anchors 110 may have a relatively straight configuration when housed in delivery device 108, perhaps with two sharpened tips and a loop in between the tips. Upon deployment from delivery device 108, the tips of anchor 110 may curve in opposite directions to form two semi-circles, circles, ovals, overlapping helices or the like. This is but one example of a type of self-securing anchor which may be delivered to a valve annulus. Typically, multiple coupled anchors 110 are delivered, and the anchors 110 are drawn together to tighten the valve annulus. Methods for anchor delivery and for drawing anchors together are described further below.

[0063] Although delivery device 108 is shown having a circular cross-sectional shape in FIGS. 2C and 2D, it may alternatively have any other suitable shape. In one embodiment, for example, it may be advantageous to provide a delivery device having an ovoid or elliptical cross-sectional shape. Such a shape may help ensure that the device is aligned, when positioned between in a corner formed by a ventricular wall and a valve leaflet, such that one or more openings in the delivery device is oriented to deliver the anchors into valve annulus tissue. To further enhance contacting of the valve annulus and/or orientation of the delivery device, some embodiments may further include an expandable member, coupled with the delivery device, which expands to urge or press or wedge the delivery device into the corner formed by the ventricle wall and the leaflet to contact the valve annulus. Such enhancements are described further below.

[0064] With reference now to FIG. 3, one embodiment of a portion of an anchor delivery device 200 suitably includes an elongate shaft 204 having a distal portion 202 configured to deliver a plurality of anchors 210, coupled with a tether 212, to tissue of a valve annulus. Tethered anchors 210 are housed within a housing 206 of distal portion 202, along with one or more anchor retaining mandrels 214 and an expandable member 208. Many variations may be made to one or more of these features, and various parts may be added or eliminated, without departing from the scope of the invention. Some of these variations are described further below, but no specific embodiment(s) should be construed to limit the scope of the invention as defined by the appended claims.

[0065] Housing 206 may be flexible or rigid in various embodiments. In some embodiments, for example, flexible housing 206 may be comprised of multiple segments configured such that housing 206 is deformable by tensioning a tensioning member coupled to the segments. In some embodiments, housing 206 is formed from an elastic material having a geometry selected to engage and optionally shape or constrict the valve annulus. For example, the rings may be formed from super-elastic material, shape memory alloy such as Nitinol, spring stainless steel, or the like. In other instances, housing 206 could be formed from an inflatable or other structure can be selectively rigidified in situ, such as a gooseneck or lockable element shaft, any of the rigidifying structures described above, or any other rigidifying structure.

[0066] “Anchors,” for the purposes of this application, is defined to mean any fasteners. Thus, anchors 210 may comprise C-shaped or semicircular hooks, curved hooks of other shapes, straight hooks, barbed hooks, clips of any kind, T-tags, or any other suitable fastener(s). In one embodiment, as described above, anchors may comprise two tips that curve in opposite directions upon deployment, forming two intersecting semi-circles, circles, ovals, helices or the like. In some

embodiments, anchors **210** are self-deforming. By “self-deforming” it is meant that anchors **210** change from a first undeployed shape to a second deployed shape upon release of anchors **210** from restraint in housing **206**. Such self-deforming anchors **210** may change shape as they are released from housing **206** and enter valve annulus tissue, to secure themselves to the tissue. Thus, a crimping device or other similar mechanism is not required on distal end **202** to apply force to anchors **210** to attach them to annular tissue.

[0067] Self-deforming anchors **210** may be made of any suitable material, such as a super-elastic or shape-memory material like Nitinol or spring stainless steel. In other embodiments, anchors **210** may be made of a non-shape-memory material and made be loaded into housing **206** in such a way that they change shape upon release. Alternatively, anchors **210** that are not self-deforming may be used, and such anchors may be secured to tissue via crimping, firing or the like. Even self-securing anchors may be crimped in some embodiments, to provide enhanced attachment to tissue. In some embodiments, anchors **210** may comprise one or more bioactive agent. In another embodiment, anchors **210** may comprise electrodes. Such electrodes, for example, may sense various parameters, such as but not limited to impedance, temperature and electrical signals. In other embodiments, such electrodes may be used to supply energy to tissue at ablation or sub-ablation amounts. Delivery of anchors may be accomplished by any suitable device and technique, such as by simply releasing the anchors by hydraulic balloon delivery as discussed further below. Any number, size and shape of anchors **210** may be included in housing **206**.

[0068] In one embodiment, anchors **210** are generally C-shaped or semicircular in their undeployed form, with the ends of the C being sharpened to penetrate tissue. Midway along the C-shaped anchor **210**, an eyelet may be formed for allowing slidable passage of tether **212**. To maintain anchors **210** in their C-shaped, undeployed state, anchors **210** may be retained within housing **206** by two mandrels **214**, one mandrel **214** retaining each of the two arms of the C-shape of each anchor **210**. Mandrels **214** may be retractable within elongate catheter body **204** to release anchors **210** and allow them to change from their undeployed C-shape to a deployed shape. The deployed shape, for example, may approximate a complete circle or a circle with overlapping ends, the latter appearing similar to a key ring. Such anchors are described further below, but generally may be advantageous in their ability to secure themselves to annular tissue by changing from their undeployed to their deployed shape. In some embodiments, anchors **210** are also configured to lie flush with a tissue surface after being deployed. By “flush” it is meant that no significant amount of an anchor protrudes from the surface, although some small portion may protrude.

[0069] Tether **212** may be one long piece of material or two or more pieces and may comprise any suitable material, such as suture, suture-like material, a Dacron strip or the like. Retaining mandrels **214** may also have any suitable configuration and be made of any suitable material, such as stainless steel, titanium, Nitinol, or the like. Various embodiments may have one mandrel, two mandrels, or more than two mandrels.

[0070] In some embodiments, anchors **210** may be released from mandrels **214** to contact and secure themselves to annular tissue without any further force applied by delivery device **200**. Some embodiments, however, may also include one or more expandable members **208**, which may be expanded to help drive anchors **210** into tissue. Expandable member(s)

208 may have any suitable size and configuration and may be made of any suitable material(s). Hydraulic systems such as expandable members are known in the art, and any known or as yet undiscovered expandable member may be included in housing **206** as part of the present invention.

[0071] Referring now to FIGS. **4** and **5**, a segment of a distal portion **302** of an anchor delivery device suitably includes a housing **306**, multiple tensioning members **320** for applying tension to housing **306** to change its shape, two anchor retaining mandrels **314** slidably disposed in housing **306**, multiple anchors **310** slidably coupled with a tether **312**, and an expandable member **308** disposed between anchors **310** and housing **306**. As can be seen in FIGS. **4** and **5**, housing **306** may include multiple segments to allow the overall shape of housing **306** to be changed by applying tension to tensioning members **320**. As also is evident from the drawings, “C-shaped” anchors **310** may actually have an almost straight configuration when retained by mandrels **314** in housing **306**. Thus, for the purposes of this application, “C-shaped” or “semicircular” refers to a very broad range of shapes including a portion of a circle, a slightly curved line, a slightly curved line with an eyelet at one point along the line, and the like.

[0072] With reference now to FIG. **6**, the same segment of distal portion **302** is shown, but mandrels **314** have been withdrawn from two mandrel apertures **322**, to release anchors **310** from housing **306**. Additionally, expandable member **308** has been expanded to drive anchors out of housing **306**. Anchors **310**, having been released from mandrels **314**, have begun to change from their undeployed, retained shape to their deployed, released shape.

[0073] Referring now to FIGS. **7A-7E**, a cross-section of a distal portion **402** of an anchor delivery device is shown in various stages of delivering an anchor to tissue of a valve annulus VA. In FIG. **7A**, distal portion **402** is positioned against the valve annulus, an anchor **410** is retained by two mandrels **414**, a tether **412** is slidably disposed through an eyelet on anchor **410**, and an expandable member **408** is coupled with housing **406** in a position to drive anchor **410** out of housing **406**. When retained by mandrels **414**, anchor **410** is in its undeployed shape. As discussed above, mandrels **414** may be slidably retracted, as designated by the solid-tipped arrows in FIG. **7A**, to release anchor **410**. In various embodiments, anchors **410** may be released one at a time, such as by retracting mandrels **414** slowly, may be released in groups, or may all be released simultaneously, such as by rapid retraction of mandrels **414**.

[0074] In FIG. **7B**, anchor **410** has begun to change from its undeployed shape to its deployed shape (as demonstrated by the hollow-tipped arrows) and has also begun to penetrate the annular tissue VA. Empty mandrel apertures **422** demonstrate that mandrels **414** have been retracted at least far enough to release anchor **410**. In FIG. **7B**, expandable member **408** has been expanded to drive anchor **410** partially out of housing **406** and further into the valve annulus VA. Anchor **410** also continues to move from its undeployed towards its deployed shape, as shown by the hollow-tipped arrows. In FIG. **7D**, anchor **410** has reached its deployed shape, which is roughly a completed circle with overlapping ends or a “key ring” shape. In FIG. **7E**, delivery device **402** has been removed, leaving a tethered anchor in place in the valve annulus. Of course, there will typically be a plurality of tethered anchors

secured to the annular tissue. Tether **412** may then be cinched to apply force to anchors **410** and cinch and tighten the valve annulus.

[0075] With reference now to FIGS. **8A** and **8B**, a diagrammatic representation of another embodiment of coupled anchors is shown. Here, anchors **510** are coupled to a self-deforming or deformable coupling member or backbone **505**. Backbone **505** may be fabricated, for example, from Nitinol, spring stainless steel, or the like, and may have any suitable size or configuration. In one embodiment, as in FIG. **8A**, backbone **505** is shaped as a generally straight line when held in an undeployed state, such as when restrained within a housing of an anchor delivery device. When released from the delivery device, backbone **505** may change to a deployed shape having multiple bends, as shown in FIG. **8B**. By bending, backbone **505** shortens the longitudinal distance between anchors, as demonstrated by the solid-tipped arrows in FIG. **8B**. This shortening process may act to cinch a valve annulus into which anchors **510** have been secured. Thus, anchors **510** coupled to backbone **505** may be used to cinch a valve annulus without using a tether or applying tethering force. Alternatively, a tether may also be coupled with anchors **510** to further cinch the annulus. In such an embodiment, backbone **505** will be at least partially conformable or cinchable, such that when force is applied to anchors **510** and backbone **505** via a tether, backbone **505** bends further to allow further cinching of the annulus.

[0076] Referring now to FIGS. **9A-9C**, in one embodiment a flexible distal portion of an anchor delivery device **520** suitably includes a housing **522** coupled with an expandable member **524**. Housing **522** may be configured to house multiple coupled anchors **526** and an anchor contacting member **530** coupled with a pull cord **532**. Housing **522** may also include multiple apertures **528** for allowing egress of anchors **526**. For clarity, delivery device **520** is shown without a tether in FIGS. **9A** and **9C**, but FIG. **9B** shows that a tether **534** may extend through an eyelet, loop or other portion of each anchor **526**, and may exit each aperture **528** to allow for release of the plurality of anchors **526**. The various features of this embodiment are described further below.

[0077] In the embodiment shown in FIGS. **9A-9C**, anchors **526** are relatively straight and lie relatively in parallel with the long axis of delivery device **522**. Anchor contacting member **530**, which may comprise any suitable device, such as a ball, plate, hook, knot, plunger, piston, or the like, generally has an outer diameter that is nearly equal to or slightly less than the inner diameter of housing **522**. Contacting member **530** is disposed within the housing, distal to a distal-most anchor **526**, and is retracted relative to housing **522** by pulling pull cord **532**. When retracted, anchor contacting member **530** contacts and applies force to a distal-most anchor **526** to release cause that anchor **526** to exit housing **522** via one of the apertures **528**. Contacting member **530** is then pulled farther proximally to contact and apply force to the next anchor **526** to deploy that anchor **526**, and so on.

[0078] Retracting contacting member **530** to push anchors **526** out of apertures **528** may help cause anchors **526** to avidly secure themselves to adjacent tissue. Using anchors **526** that are relatively straight/flat when undeployed allows anchors **526** with relatively large deployed sizes to be disposed in (and delivered from) a relatively small housing **522**. In one embodiment, for example, anchors **526** that deploy into a shape approximating two intersecting semi-circles, circles, ovals, helices, or the like, and that have a radius of one of the

semi-circles of about 3 mm may be disposed within a housing **522** having a diameter of about 5 French (1.67 mm) and more preferably 4 French (1.35 mm) or even smaller. Such anchors **526** may measure about 6 mm or more in their widest dimension. In some embodiments, housing **522** may have a diametrical dimension ("d") and anchor **526** may have a diametrical dimension ("D") in the deployed state, and the ratio of D to d may be at least about 3.5. In other embodiments, the ratio of D to d may be at least about 4.4, and more preferably at least about 7, and even more preferably at least about 8.8. These are only examples, however, and other larger or smaller anchors **526** may be disposed within a larger or smaller housing **522**. Furthermore, any convenient number of anchors **526** may be disposed within housing **522**. In one embodiment, for example, housing **522** may hold about 1-20 anchors **526**, and more preferably about 3-10 anchors **526**. Other embodiments may hold more anchors **526**.

[0079] Anchor contacting member **530** and pull cord **532** may have any suitable configuration and may be manufactured from any material or combination of materials. In alternative embodiments, contacting member **530** may be pushed by a pusher member to contact and deploy anchors **526**. Alternatively, any of the anchor deployment devices and methods previously described may be used.

[0080] Tether **534**, as shown in FIG. **9B**, may comprise any of the tethers **534** or tether-like devices already described above, or any other suitable device. Tether **534** is generally attached to a distal-most anchor **526** at an attachment point **536**. The attachment itself may be achieved via a knot, weld, adhesive, or by any other suitable attachment means. Tether **234** then extends through an eyelet, loop or other similar configuration on each of the anchors **526** so as to be slidably coupled with the anchors **526**. In the embodiment shown, tether **534** exits each aperture **528**, then enters the next-most-proximal aperture, passes slidably through a loop on an anchor **526**, and exits the same aperture **528**. By entering and exiting each aperture **528**, tether **534** allows the plurality of anchors **526** to be deployed into tissue and cinched. Other configurations of housing **522**, anchors **526** and tether **534** may alternatively be used. For example, housing **522** may include a longitudinal slit through which tether **534** may pass, thus allowing tether **534** to reside wholly within housing before deployment.

[0081] Expandable member **524** is an optional feature of anchor delivery device **520**, and thus may be included in some embodiments and not in others. In other words, a distal portion of anchor delivery device **520** may include housing, contents of housing, and other features either with or without an attached expandable member. Expandable member **524** may comprise any suitable expandable member currently known or discovered in the future, and any method and substance(s) may be used to expand expandable member **524**. Typically, expandable member **524** will be coupled with a surface of housing **522**, will have a larger radius than housing **522**, and will be configured such that when it is expanded as housing **522** nears or contacts the valve annulus, expandable member **524** will push or press housing **522** into enhanced contact with the annulus. For example, expandable member **524** may be configured to expand within a space near the corner formed by a left ventricular wall and a mitral valve leaflet.

[0082] With reference now to FIGS. **10A-10F**, a method is shown for applying a plurality of tethered anchors **526** to a valve annulus VA in a heart. As shown in FIG. **10A**, an anchor

delivery device **520** is first contacted with the valve annulus VA such that openings **528** are oriented to deploy anchors **526** into the annulus. Such orientation may be achieved by any suitable technique. In one embodiment, for example, a housing **522** having an elliptical cross-sectional shape may be used to orient openings **528**. As just described, contact between housing **522** and the valve annulus VA may be enhanced by expanding expandable member **524** to wedge housing within a corner adjacent the annulus.

[0083] Generally, delivery device **520** may be advanced into any suitable location for treating any valve by any suitable advancing or device placement method. Many catheter-based, minimally invasive devices and methods for performing intravascular procedures, for example, are well known, and any such devices and methods, as well as any other devices or method later developed, may be used to advance or position delivery device **520** in a desired location. For example, in one embodiment a steerable guide catheter is first advanced in retrograde fashion through an aorta, typically via access from a femoral artery. The steerable catheter is passed into the left ventricle of the heart and thus into the space formed by the mitral valve leaflets, the left ventricular wall and cordae tendineae of the left ventricle. Once in this space, the steerable catheter is easily advanced along a portion (or all) of the circumference of the mitral valve. A sheath is advanced over the steerable catheter within the space below the valve leaflets, and the steerable catheter is removed through the sheath. Anchor delivery device **520** may then be advanced through the sheath to a desired position within the space, and the sheath may be removed. In some cases, an expandable member coupled to delivery device **520** may be expanded to wedge or otherwise move delivery device **520** into the corner formed by the left ventricular wall and the valve leaflets to enhance its contact with the valve annulus. Of course, this is but one exemplary method for advancing delivery device **520** to a position for treating a valve, and any other suitable method, combination of devices, etc. may be used.

[0084] As shown in FIG. 10B, when delivery device **520** is positioned in a desired location for deploying anchors **526**, anchor contacting member **530** is retracted to contact and apply force to a most-distal anchor **526** to begin deploying anchor **526** through aperture **528** and into tissue of the valve annulus VA. FIG. 10C show anchor **526** further deployed out of aperture **528** and into valve annulus VA. FIG. 10D shows the valve annulus VA transparently so that further deployment of anchors **526** can be seen. As shown, in one embodiment of the invention, anchors **526** include two sharpened tips that move in opposite directions upon release from housing **522** and upon contacting the valve annulus VA. Between the two sharpened tips, an anchor **526** may be looped or have any other suitable eyelet or other device for allowing slidable coupling with a tether **534**.

[0085] Referring now to FIG. 10E, anchors **526** are seen in their fully deployed or nearly fully deployed shape, with each pointed tip (or “arm”) of each anchor **526** having curved to form a circle or semi-circle. Of course, in various embodiments anchors **526** may have any other suitable deployed and undeployed shapes, as described more fully above. FIG. 10F shows anchors **526** deployed into the valve annulus VA and coupled with tether **534**, with the distal-most anchor **526** coupled attached fixedly to tether **524** at attachment point **536**. At this stage, tether **534** may be cinched to tighten the annulus, thus reducing valve regurgitation. In some embodiments, valve function may be monitored by means such as

echocardiogram and/or fluoroscopy, and tether **534** may be cinched, loosened, and adjusted to achieve a desired amount of tightening as evident via the employed visualization technique(s). When a desired amount of tightening is achieved, tether **534** is then attached to a most-proximal anchor **526** (or two or more most-proximal anchors **526**), using any suitable technique, and tether **534** is then cut proximal to the most-proximal anchor **526**, thus leaving the cinched, tethered anchors **526** in place along the valve annulus VA. Attachment of tether **534** to the most-proximal anchor(s) **526** may be achieved via adhesive, knotting, crimping, tying or any other technique, and cutting tether **534** may also be performed via any technique, such as with a cutting member coupled with housing **522**.

[0086] In one embodiment, cinching tether **534**, attaching tether **534** to most-proximal anchor **526**, and cutting tether **534** are achieved using a termination device (not shown). The termination device may comprise, for example, a catheter advancable over tether **534** that includes a cutting member and a nitinol knot or other attachment member for attaching tether **534** to most-proximal anchor. The termination catheter may be advanced over tether **534** to a location at or near the proximal end of the tethered anchors **526**. It may then be used to apply opposing force to the most-proximal anchor **526** while tether **534** is cinched. Attachment and cutting members may then be used to attach tether **534** to most-proximal anchor **526** and cut tether **534** just proximal to most-proximal anchor **526**. Such a termination device is only one possible way of accomplishing the cinching, attachment and cutting steps, and any other suitable device(s) or technique(s) may be used.

[0087] In some embodiments, it may be advantageous to deploy a first number of anchors **526** along a first portion of a valve annulus VA, cinch the first anchors to tighten that portion of the annulus, move the delivery device **520** to another portion of the annulus, and deploy and cinch a second number of anchors **526** along a second portion of the annulus. Such a method may be more convenient, in some cases, than extending delivery device **520** around all or most of the circumference of the annulus, and may allow a shorter, more maneuverable housing **522** to be used.

[0088] In an embodiment similar to that shown in FIGS. 10A-10F, an analogous method may be used but anchors **526** may be driven out of delivery device **520** through a biocompatible material attached to delivery device **520**, thereby attaching the biocompatible material to the valve annulus VA. For example, in one embodiment a Dacron strip may be attached to delivery device **520**, extending along device **520** and covering apertures **528**. Anchors **526** are then driven out of delivery device **520**, through the Dacron strip, into the valve annulus VA, thus detaching the Dacron strip from device **520** and attaching it to the valve annulus VA. Such a biocompatible material may facilitate tissue ingrowth of anchors **526** and may enhance attachment generally to the valve annulus VA. In an alternative embodiment, multiple pieces of biocompatible material, such as separate pieces of material disposed over each of apertures **528**, may be used. For example, in one embodiment multiple discs of Dacron material are disposed over multiple apertures **528**.

[0089] In another embodiment, a distal portion of delivery device **520** may be detachable from a proximal portion of delivery device **520**. Such an embodiment may be configured such that when anchors **526** are deployed from device **520**, the distal portion of device **520** detaches from the proximal por-

tion and is attached, via anchors 526, to the valve annulus VA. In one embodiment, for example, anchors 526 may pierce through the distal portion of device 520, rather than exiting device 520 through apertures 528. The distal portion may be detachable via any suitable means, such as perforations or the like.

[0090] Referring now to FIG. 11, a cross-sectional depiction of a heart H is shown with an anchor delivery device guide catheter 550 advanced through the aorta A and into the left ventricle LV. In a preferred embodiment, this access route to the subannular space and the valve annulus may be used. Guide catheter 550 is generally a flexible elongate catheter which may have one or more curves or bends toward its distal end to facilitate placement of the distal end of catheter 550 in a subannular space 552. Subannular space 552, which has been described above in detail, is generally defined by the left ventricular wall, the mitral valve leaflets MVL, and cordae tendinae, and travels along most or all of the circumference of the valve annulus. The distal end of guide catheter 550 may be configured to be positioned at an opening into space 552 or within space 552, such that subsequent catheter devices may be passed through guide catheter 550 into space 552. In some embodiments, it may be advantageous to provide guide catheter 550 with a curvable portion with a radius in an expanded/curved state that is greater than a radius of the valve annulus. For example, in one embodiment guide catheter 550 in the expanded state has a radius about 25%-50% larger than the valve annulus.

[0091] With reference now to FIG. 11A, a distal portion of guide catheter 550 is shown, with an anchor delivery device 558 extending through it and out of its distal end. As shown, in one embodiment guide catheter 550 includes at least one bend 551 or curvature, and anchor delivery device 558 is pre-shaped to include at least one corresponding bend 553, that has approximately the same radius of curvature as the bend 551 in guide catheter 550. In some embodiments (not shown), guide catheter 550 may have multiple bends 551, and anchor delivery device 558 may have multiple corresponding bends 553. In the embodiment shown, anchor delivery device 558 includes a proximal bend 553, which corresponds to the bend 551 in guide catheter 550, and a distal bend 555. By matching the radii of curvature of the proximal bend 553 and the guide catheter bend 551, the distal portion of anchor delivery device 558 becomes automatically oriented (when advanced through guide catheter 550) such that one or more anchor delivery apertures 557 are in contact with the valve annulus (not shown). Moreover, distal bend 555 may have a radius of curvature that matches approximately a radius of curvature of a valve annulus. Alternatively, distal bend 555 may have a radius of curvature greater than a valve annulus radius of curvature, such that the distal portion of anchor delivery device 558 tends to push radially outward, enhancing contact of the device 558 with valve annulus tissue. Such greater radii of curvature are described in greater detail below. Proximal bend 553 and distal bend 555 may therefore have any suitable angles relative to one another and relative to the more proximal portion of anchor delivery device 558. In some embodiments, anchor delivery device 558 is also steerable.

[0092] With reference now to FIG. 11B, in the embodiment described immediately above and/or in alternative embodiments, an anchor delivery device 588 and a guide catheter 590 may include one or more corresponding (or "registering") bends or orientation portions 592a, 592b at other locations along their lengths. In other words, although bends 551, 553,

555 are shown in FIG. 11A at or near the distal ends of guide catheter 550 and anchor delivery device 558, similar bends could be formed at more proximal locations. For example, FIG. 11B shows guide catheter 590 with orientation portion 592a having a chosen shape when relaxed. The chosen shape may lie along a two-dimensional or three-dimensional path. Anchor delivery device 588 has a corresponding orientation portion 592b along its length which is complementary to the shape of orientation portion 592a. The chosen shape may also be created by the application of energy, mechanical manipulation or the like. Such orientation portions 592a, 592b could be used for further registering or orienting delivery device 588 to a desired orientation. Typically, when orientation portions 592a, 592b are axially aligned, which can be indicated by orientation markers at the proximal ends of guide catheter 590 and anchor delivery device 588 external of the patient, proper rotary orientation can be sensed tactically by the physician to help insure the distal end of anchor delivery device 588 is properly oriented. Delivery device 588 may be rotated, advanced or moved in any suitable fashion within guide catheter 590 to achieve a desired orientation. The use of one or more complementary orientation portions 592a, 592b may be used with any of a number of various embodiments of guide catheters and anchor delivery devices.

[0093] In a number of cases, and with reference now to FIGS. 12A-12D, it may be advantageous to provide further support to an anchor delivery device 658, to support the device 658 against valve annulus tissue and/or to push the device 658 against valve annulus tissue to enhance contact with, and anchor delivery into, the tissue. In one embodiment, as shown in FIG. 12A, a helical support member 652 may be coupled with a distal end of anchor delivery device 658 and may be extended into the left ventricle of a heart (or other heart chamber in other embodiments) to contact the heart wall 651 and thus support anchor delivery device 658 against the valve annulus tissue. In alternative embodiments, helical support member 651 may extend out of a guide catheter 650 to contact the heart wall 651 and support anchor delivery device 658. Any suitable means may be used for extending helical member 652 into the left ventricle or other chamber. For example, helical member 652 is pushed out of guide catheter 650 in one embodiment, but may alternatively be extended out of anchor delivery device 658. Helical member 652 may be made of any suitable material, such as but not limited to Nitinol, stainless steel or the like.

[0094] In an alternative embodiment, pictured in FIG. 12B, a deployable U-shaped support member 662 may be movably coupled with a distal portion of an anchor delivery device 668, both of which are advanceable through a guide catheter 660. Upon being advanced out of the distal end of guide catheter 660, U-shaped member 662 may automatically spring out, or alternatively may be manually manipulated to extend outward, to contact the inner surface of the heart wall and/or to contact a papillary muscle 663. As shown in FIG. 12B, in one embodiment U-shaped member 663 contacts an intersection of a papillary muscle 663 with the heart wall, and thus provides upward support (solid-tipped arrows) to anchor delivery device 668. Again, such a U-shaped member 662 may automatically deform from a straight configuration for delivery through guide catheter 660 into a U-shaped configuration, such as if member 662 is made of Nitinol, spring stainless steel, or other shape memory or super-elastic material. Alternatively, U-shaped member 662 may be connected to anchor delivery device 668 at or near the distal end of the

device 668 and may be pushed distally to force the U-shaped member 662 to expand into its U-shape. In an alternative embodiment, U-shaped member 662 may be attached proximally and may be pulled into its expanded configuration. Any suitable method for changing the shape of U-shaped member 662 from straight to U-shaped may be used in various embodiments.

[0095] As shown in FIG. 12C, U-shaped member 662 may optionally include an expandable member 667, such as an inflatable balloon. Expandable member 667 may be expanded to provide further force against and support of anchor delivery device 668, to enhance its contact with valve annulus tissue. In another embodiment, as shown in FIG. 12D, multiple spring members 672 may be coupled with a distal end of an anchor delivery device 678 to provide force against an inner surface of a heart wall (solid tipped arrows) to thus support anchor delivery device 678 against annulus tissue (hollow tipped arrows). Thus, various embodiments of the invention may include any of a number of suitable support devices for enhancing support of an anchor delivery device against valve annulus tissue, thus enhancing the ability of the delivery device to delivery tissue anchors into the annulus.

[0096] Referring now to FIGS. 13A-13C, in some embodiments it may be advantageous to provide one or more devices to enhance the attachment of a terminal tissue anchor 710 to valve annulus tissue VA. Typically, in attaching tissue anchors to valve annulus tissue VA, a first tethered anchor (not shown) is attached, and subsequent anchors are then attached, ending in a final or terminal anchor 710. A tether 718 is then cinched, to apply force between the attached anchors (hollow arrow), thus cinching the valve annulus VA. Tether 718 is then typically attached by any suitable means to terminal anchor 710 and then cut or otherwise detached proximal to the terminal anchor 710, leaving the cinched, tethered anchors in place, attached to the valve annulus VA. To relieve some of the tension placed on terminal anchor 710 and/or to provide additional attachment/anchoring strength to the terminal end of the tethered anchors, one or more locking members 714 may be deployed at or near the terminal end. For example, in one embodiment locking member 714 comprises a cylinder slidably disposed over tether 718, with prongs 712 extending from one end of the cylinder. Locking member 714 is deployed out of the distal end of a termination catheter, guide catheter or the like (not shown) and is then slid along tether 718, such that prongs 712 contact and enter into valve annulus tissue VA. In one embodiment, a pusher member 716, such as a ball slidably disposed over tether 718, may be used to push locking member 714 forward and into engagement with tissue, as shown in FIG. 13B and as designated by solid tipped arrows. In some embodiments, locking member 714 engages with terminal anchor 710, as shown in FIGS. 13B and 13C, though such engagement is not required. Once locking member 714 is fully engaged with valve tissue VA, tether 718 is cut proximal to locking member 714. In some embodiments, pusher member 716 remains in place, while in others it may be removed before cutting tether 718.

[0097] A number of different variations of locking members are contemplated in various embodiments. For example, a two-pronged member may be used, with the prongs deployable from a delivery position to an expanded configuration, and with the prongs optionally engaging with the terminal anchor 710. In another embodiment, multiple prongs may be aligned in a linear fashion along a locking member, such as in a rake-like configuration. Yet another embodiment include

two prongs for engaging with the terminal anchor 710 and another prong for engaging with valve annulus tissue VA. Thus, any of a number of different embodiments may be employed as part of the present invention. Such locking members may be constructed from any suitable material or combination of materials, such as Nitinol, spring stainless steel and/or other shape memory or super-elastic materials.

[0098] FIGS. 14A-14F demonstrate a method for advancing an anchor delivery device to a position for treating a mitral valve MV. The mitral valve MV, including mitral valve leaflets MVL are represented diagrammatically from an inferior perspective looking up, to depict a method for delivering a device into subannular space 552. In FIG. 14A, first guide catheter 550 is shown extending up to or into subannular space 552, as in FIG. 11. As shown in FIG. 14B, in one method a second guide catheter 554 may be advanced through first guide catheter 550 to pass through/along subannular space 554. This second guide catheter 554 is steerable in one embodiment, as will be described further below, to help conform second guide catheter 554 to subannular space 552.

[0099] Next, as in FIG. 14C, a guide sheath 556 may be passed over second guide catheter 554 to extend along subannular space. Sheath 556 is generally a flexible, tubular member that can be passed over second guide catheter 554 and within first guide catheter 550. To enhance passage and exchange, any of these and other described catheter members, sheath members, or the like may be manufactured from and/or coated with one or more friction resistant materials. Once sheath 556 is in place, second guide catheter 554 may be withdrawn, as shown in FIG. 14D. As shown in FIG. 14E, an anchor delivery device 558 may then be advanced through sheath 556 to a position for treating the mitral valve MV. Sheath 556 may then be withdrawn, as in FIG. 14F, leaving anchor delivery device 558 in place for performing a treatment. A valve annulus treatment may be performed, as described extensively above, and anchor delivery device 558 may be withdrawn. In some embodiments, anchor delivery device 558 is used to treat one portion of the valve annulus and is then moved to another portion, typically the opposite side, to treat the other portion of the annulus. In such embodiments, any one or more of the steps just described may be repeated. In some embodiments, anchor delivery device 558 is withdrawn through first guide catheter 550, and first guide catheter 550 is then withdrawn. In alternative embodiments, first guide catheter 550 may be withdrawn before anchor delivery device 558.

[0100] In various embodiments, alternative means may be used to urge anchor delivery device 558 into contact with the valve annulus. For example, in one embodiment an expandable member is coupled with anchor delivery device 558 and expanded within the subannular space 552. In an alternative embodiment, a magnet may be coupled with anchor delivery device 558, and another anchor may be disposed within the coronary sinus, in proximity to the first magnet. The two magnets may attract one another, thus pulling the anchor delivery device 558 into greater contact with the annulus. In another embodiment, anchor delivery device 558 in an expanded (or deployed) state may have a radius of curvature that is larger than the radius of curvature of the mitral valve annulus, thus causing device 558 to be urged against the annulus. In one embodiment, for example, the radius of curvature of device 558 in the expanded/deployed state is about 25%-50% larger than the radius of curvature of the mitral valve annulus.

[0101] Various embodiments may also include visualizing the annulus using a visualization member coupled with the anchor delivery device **558** or separate from the device **558**. In some embodiments, anchors may be driven through a strip of detachable, biocompatible material, such as Dacron, that is coupled with anchor delivery device **558** but that detaches to affix to the valve annulus via the anchors. In some embodiments, the strip may then be cinched to tighten the annulus. In other embodiments, the anchors may be driven through a detachable, biocompatible, distal portion of the guide sheath **556**, and guide sheath **556** may then remain attached to the annulus via the anchors. Again, in some embodiments, the detached sheath may be cinched to tighten the annulus.

[0102] Of course, the method just described is but one embodiment of a method for delivering an anchor delivery device to a location for treating a valve annulus. In various alternative embodiments, one or more steps may be added, deleted or modified while achieving a similar result. In some embodiments, a similar method may be used to treat the mitral valve from a superior/right atrial position or to treat another heart valve. Additionally, other devices or modifications of the system just described may be used in other embodiments.

[0103] With reference now to FIGS. **15A** and **15B**, one embodiment of a steerable catheter device **560** is shown. Steerable catheter device **560** may be used in a method such as that just described in reference to FIGS. **14A-14F**, for example in performing a function similar to that performed by second guide catheter **554**. In other embodiments, catheter device **560** may perform any other suitable function. As shown, catheter device **560** suitably includes an elongate catheter body having a proximal portion **562** and a distal portion **564**. At least one tensioning member **568**, such as but not limited to a tensioning cord, extends from proximal portion **562** to distal portion **564** and is coupled with the distal portion **564** and at least one tensioning actuator **570/572** on the proximal portion. Tensioning actuator **570/572** may include, for example, a knob **570** and a barrel **572** for wrapping and unwrapping tensioning member **568** to apply and remove tension. Tensioning member **568** is coupled with distal portion **564** at one or more connection points **580**. In some embodiments, catheter device **560** includes a proximal housing **571**, handle or the like, coupled to the proximal end of proximal portion **562** via a hub **576** or other means. Housing **571** may be coupled with tensioning actuator **570/572** and may include one or more arms **574** for infusing fluid or for other functions. In the embodiment shown, arm **574** and housing **571** include a lumen **567** that is in fluid communication with a fluid lumen **566** of the catheter body. Fluid may be introduced through arm **574** to pass through fluid lumen **566** to provide, for example, for contrast material at the distal tip of catheter device **560** to enhance visualization of device **560** during a procedure. Any other suitable fluid(s) may be passed through lumens **567/566** for any other purpose. Another lumen **578** may be included in distal portion **564**, through which tensioning member **568** passes before attaching at a distal location along distal portion **564**.

[0104] FIG. **15B** shows catheter device **560** in a deformed/bent configuration, after tension has been applied to distal portion **564** by applying tension to tensioning member **568**, via knob **570** and barrel **572**. The bend in distal portion **564** will allow it to conform more readily to a valve annulus, while catheter device **560** in its straight configuration will be more amenable to passage through vasculature of the patient. Ten-

sioning member **568** may be manufactured from any suitable material or combination of materials, such as but not limited to Nitinol, polyester, nylon, polypropylene and/or other polymers. Some embodiments may include two or more tensioning members **568** and/or two or more tensioning actuators **570/572** to provide for changes in shape of distal portion **564** in multiple directions. In alternative embodiments, knob **570** and barrel **572** may be substituted with any suitable devices, such as a pull cord, button, lever or other actuator. Various alternatives may also be substituted for tensioning member **568** in various embodiments. For example, shaped expandable members, shape memory members and/or the like may be used to change the shape of distal portion **564**.

[0105] Generally, proximal portion **562** of the catheter body is less flexible than distal portion **564**. Proximal portion **562** may be made of any suitable material, such as PEBAX, FEP, nylon, polyethylene and/or the like, and may include a braided material, such as stainless steel, to provide stiffness and strength. Distal portion **564** may be made of similar or other materials, but the braided material is typically not included, to provide for greater flexibility. Both proximal and distal portions **562/564** may have any suitable lengths, diameters, overall configurations and the like. In one embodiment the catheter body is approximately 140 cm in length and 6 French in diameter, but any other suitable sizes may be used in other embodiments. Either proximal portion **562**, distal portion **564** or preferably both, may be made from or coated with one or more friction resistant or lubricating material to enhance passage of device **560** through an introducer catheter and/or to enhance passage of a sheath or other device over catheter device **560**.

[0106] With reference now to FIGS. **16A-16E**, another aspect of the present invention includes improved tissue anchors for enhancing anchor attachment to valve annulus tissue. Such improved anchors typically include one or more features to help prevent the anchors from pulling out of tissue, when the anchors are placed under tension from a cinched tether, and/or to help promote tissue ingrowth of the anchors to further enhance attachment. In one embodiment, as shown in FIG. **16A**, a tissue anchor **810** includes outwardly facing hooks **812** or bends at the ends of the two arms of anchor **810**. In another embodiment, as in FIG. **16B**, a tissue anchor **820** includes inwardly facing hooks **822**. In a related embodiment, shown in FIG. **16D**, a tissue anchor **840** includes multiple bends **842**. In any of these embodiments, hooks **812**, **822** or bends **842** have been found to enhance attachment of anchors **810**, **820**, **840** to tissue and thus prevent anchor pullout. In another embodiment, shown in FIG. **16C**, two arms of a tissue anchor **830** are attached at an attachment point **832**. The attachment point **832** may be formed by any suitable technique, such as soldering or the like. In another embodiment, as in FIG. **16E**, a belt **852** may be disposed over a tissue anchor **850** to hold the two arms of the anchor together. In either of the embodiments shown in FIGS. **16C** and **16E**, holding the two arms of the anchor together has been found to reduce pullout of the anchors **830**, **850** from tissue.

[0107] In the embodiments just described or in alternative embodiments, tissue anchors may also have one or more features designed to enhance ingrowth and/or encapsulation of the anchors into annular tissue. Such features, for example, may include a coating, a porous and/or rough surface, an attachment such as a polyester band or belt, or any other

suitable surface feature or added feature. By promoting encapsulation of tissue anchors, attachment strength of the anchors to tissue is enhanced.

[0108] Referring now to FIGS. 17A-17C, in many embodiments, self-forming anchors 900 are stored in the delivery device in a straightened configuration, coupled with a tether 902, as shown in FIG. 17A. Basically, anchors 900 are held or restrained in that straightened state, while their natural configuration is curved. Thus, when the straightened anchor 900 is released from the delivery device into tissue T, the anchor 900 actually pulls itself into the tissue T, as shown in FIG. 17B, due to the storage of potential energy in the straightened state and the tendency of each of the arms 901 of anchors 900 to drive the tip of the arm into the tissue as illustrated. Arms 901 are joined together at a junction 903. Each arm 901 is braced against the other arm so that forces exerted by tissue T on each arm 901 are opposed by the other arm 901 wherein the arms are joined to one another. This eliminates the need for an anchor driving device, such as required with staples, thus substantially simplifying the assembly and method. In addition, bracing arms 901 against one another also helps to reduce or eliminate problems associated with tissue deflection. As shown by the hollow-tipped arrows in FIG. 17B, the anchor 900 pulls itself into tissue T as it assumes its natural, curved shape, and exerts forces in vertical, horizontal and curved directions. Finally, after pulling itself into tissue and assuming its natural shape, as in FIG. 17C, anchor 900 is fully embedded in the tissue T.

[0109] In an alternative embodiment, as shown in FIG. 18, anchors 910 may have one curved arm and one straight arm. Such an anchor 910 will still pull itself into tissue T, thus embedding itself and positioning the tether 912 flush with the tissue T.

[0110] Referring now to FIG. 19A, some embodiments of a valve annulus anchor device may include anchors 922, a tether 924, a distal force applying member 927 coupled with the tether 924, a termination member 926 and one or more force distributing sleeves 920 disposed over the tether 924 and between adjacent anchors 922. In one embodiment, as shown, a separate sleeve 920 may be disposed between two adjacent anchors 922a, 922b. Additional sleeves 920 may optionally be disposed between other sets of two anchors, such as anchors 922b and 922c. In FIG. 19A, only three anchors 922 are shown for simplicity, but any number of anchors 922 and sleeves 920 between anchors may be used in various embodiments. Sleeve 920 acts to distribute force applied between two adjacent anchors 922, to help prevent such anchors 922 from pulling out of tissue when force is applied to tether 924. Sleeve 922 may be made of any suitable material, such as but not limited to metals, such as Nitinol, polymers, fabrics and the like. Sleeve 922 may be a solid cylindrical member, or alternatively may have patterned cut-outs, like a stent, or be made of ribbed, woven, braided, porous, nonporous or any other suitable material, pattern,

configuration or the like. Sleeve 920 may be essentially rigid and axially incompressible, while in other embodiments it may be axially compressible. In one embodiment, sleeve 920 may be configured as two rings, disposed adjacent two anchors 922, with the rings being connected by a rod or shaft, so that tether 924 is not encircled by the sleeve 922.

[0111] With reference now to FIG. 19B, in an alternative embodiment, a sleeve 930 may be disposed over a tether 934 so as to extend between more than two anchors 932. Such a sleeve 930 may thus distribute force applied between a termination member 936 and a force applying member 937 so as to help prevent anchor pull-out from tissue. Such a sleeve 930 may include one or more openings through which one or more middle anchors may extend. Again, sleeve 930 may have any suitable configuration, size, shape or the like and be made of any suitable material or combination of materials. Sleeve 930 may extend between three, four, five or any suitable number of anchors 932 in various embodiments. In an alternative embodiment, sleeve 930 may be pierced by one or more of the anchors 932 and thus attached to valve annulus tissue.

[0112] Although the foregoing is a complete and accurate description of the present invention, the description provided above is for exemplary purposes only, and variations may be made to the embodiments described without departing from the scope of the invention. Thus, the above description should not be construed to limit the scope of the invention as described in the appended claims.

1-42. (canceled)

43. A device for constricting a valve annulus in a heart, the device comprising:

- a plurality of slidably coupled tissue anchors, each anchor including at least one tissue attachment feature for enhancing attachment of the anchor to valve annulus tissue; and
- at least one cinchable tether slidably coupled with at least some of the tissue anchors and fixedly attached to at least a first of the anchors.

44. A device as in claim 43, wherein the at least one attachment feature comprises a porous surface along at least a portion of each anchor.

45. A device as in claim 43, wherein the at least one attachment feature comprises a textured surface along at least a portion of each anchor.

46. A device as in claim 43, wherein the at least one attachment feature comprises a coated surface along at least a portion of each anchor.

47. A device as in claim 43, wherein the at least one attachment feature comprises at least one circular or hooked portion of each anchor having a small radius of curvature.

48. A device as in claim 43, wherein the at least one attachment feature comprises a barb at each end of each anchor.

49-59. (canceled)

* * * * *