



(86) **Date de dépôt PCT/PCT Filing Date:** 2012/01/05
 (87) **Date publication PCT/PCT Publication Date:** 2012/07/12
 (45) **Date de délivrance/Issue Date:** 2016/07/19
 (85) **Entrée phase nationale/National Entry:** 2013/06/27
 (86) **N° demande PCT/PCT Application No.:** US 2012/020279
 (87) **N° publication PCT/PCT Publication No.:** 2012/094460
 (30) **Priorité/Priority:** 2011/01/06 (US12/985,703)

(51) **Cl.Int./Int.Cl. E21B 4/00** (2006.01)
 (72) **Inventeur/Inventor:**
 MARCHAND, NICHOLAS, CA
 (73) **Propriétaire/Owner:**
 NATIONAL OILWELL VARCO, L.P., US
 (74) **Agent:** TOMKINS, DONALD V.

(54) **Titre : SYSTEME DE COMPENSATION DE PRESSION POUR UN ENSEMBLE DE ROULEMENTS A JOINT D'HUILE POUR MOTEUR A BOUE**

(54) **Title: PRESSURE COMPENSATION SYSTEM FOR AN OIL-SEALED MUD MOTOR BEARING ASSEMBLY**

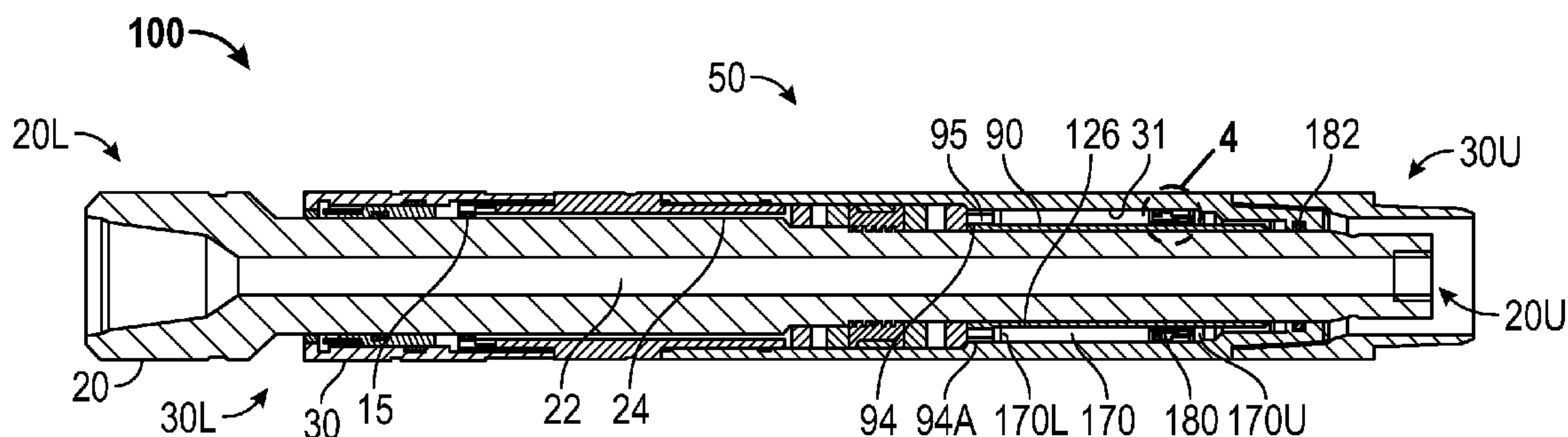

(57) **Abrégé/Abstract:**

In an oil-sealed bearing assembly in the bearing section of a mud motor, in which a mandrel is rotatably disposed within a cylindrical housing, a cylindrical sleeve is disposed coaxially and rotatably around the mandrel, with the sleeve being non-rotatably mounted to an inner surface of the housing, thereby forming an annular piston chamber forming part of a generally annular oil reservoir. The sleeve provides radial support to the mandrel along the length of the piston chamber by virtue of the flexural stiffness of the sleeve. The mandrel rotates within the sleeve, with a radial bearing being provided between the sleeve and the mandrel. An annular piston is axially movable within the piston chamber in response to variations in the volume of oil in the reservoir. The piston slides within the piston chamber without rotation relative to either the housing or the sleeve.

(12) INTERNATIONAL APPLICATION PUBLISHED UNDER THE PATENT COOPERATION TREATY (PCT)

(19) World Intellectual Property
Organization
International Bureau(43) International Publication Date
12 July 2012 (12.07.2012)(10) International Publication Number
WO 2012/094460 A2

- (51) **International Patent Classification:**
E21B 4/00 (2006.01)
- (21) **International Application Number:**
PCT/US2012/020279
- (22) **International Filing Date:**
5 January 2012 (05.01.2012)
- (25) **Filing Language:** English
- (26) **Publication Language:** English
- (30) **Priority Data:**
12/985,703 6 January 2011 (06.01.2011) US
- (71) **Applicant (for all designated States except US):** NATIONAL OILWELL VARCO, L.P. [US/US]; 7909 Parkwood Circle Drive, Houston, Texas 77036 (US).
- (72) **Inventor; and**
- (75) **Inventor/Applicant (for US only):** MARCHAND, Nicholas [CA/CA]; 9550-72 Ave., Edmonton, Alberta T6E 0Y4 (CA).
- (74) **Agent:** FALESKI, Thaddeus J.; Conley Rose, P.C., P.O. Box 3267, Houston, Texas 77253-3267 (US).
- (81) **Designated States (unless otherwise indicated, for every kind of national protection available):** AE, AG, AL, AM, AO, AT, AU, AZ, BA, BB, BG, BH, BR, BW, BY, BZ, CA, CH, CL, CN, CO, CR, CU, CZ, DE, DK, DM, DO, DZ, EC, EE, EG, ES, FI, GB, GD, GE, GH, GM, GT, HN, HR, HU, ID, IL, IN, IS, JP, KE, KG, KM, KN, KP, KR, KZ, LA, LC, LK, LR, LS, LT, LU, LY, MA, MD, ME, MG, MK, MN, MW, MX, MY, MZ, NA, NG, NI, NO, NZ, OM, PE, PG, PH, PL, PT, QA, RO, RS, RU, RW, SC, SD, SE, SG, SK, SL, SM, ST, SV, SY, TH, TJ, TM, TN, TR, TT, TZ, UA, UG, US, UZ, VC, VN, ZA, ZM, ZW.
- (84) **Designated States (unless otherwise indicated, for every kind of regional protection available):** ARIPO (BW, GH, GM, KE, LR, LS, MW, MZ, NA, RW, SD, SL, SZ, TZ, UG, ZM, ZW), Eurasian (AM, AZ, BY, KG, KZ, MD, RU, TJ, TM), European (AL, AT, BE, BG, CH, CY, CZ, DE, DK, EE, ES, FI, FR, GB, GR, HR, HU, IE, IS, IT, LT, LU, LV, MC, MK, MT, NL, NO, PL, PT, RO, RS, SE, SI, SK, SM, TR), OAPI (BF, BJ, CF, CG, CI, CM, GA, GN, GQ, GW, ML, MR, NE, SN, TD, TG).
- Published:**
— without international search report and to be republished upon receipt of that report (Rule 48.2(g))

(54) Title: PRESSURE COMPENSATION SYSTEM FOR AN OIL-SEALED MUD MOTOR BEARING ASSEMBLY

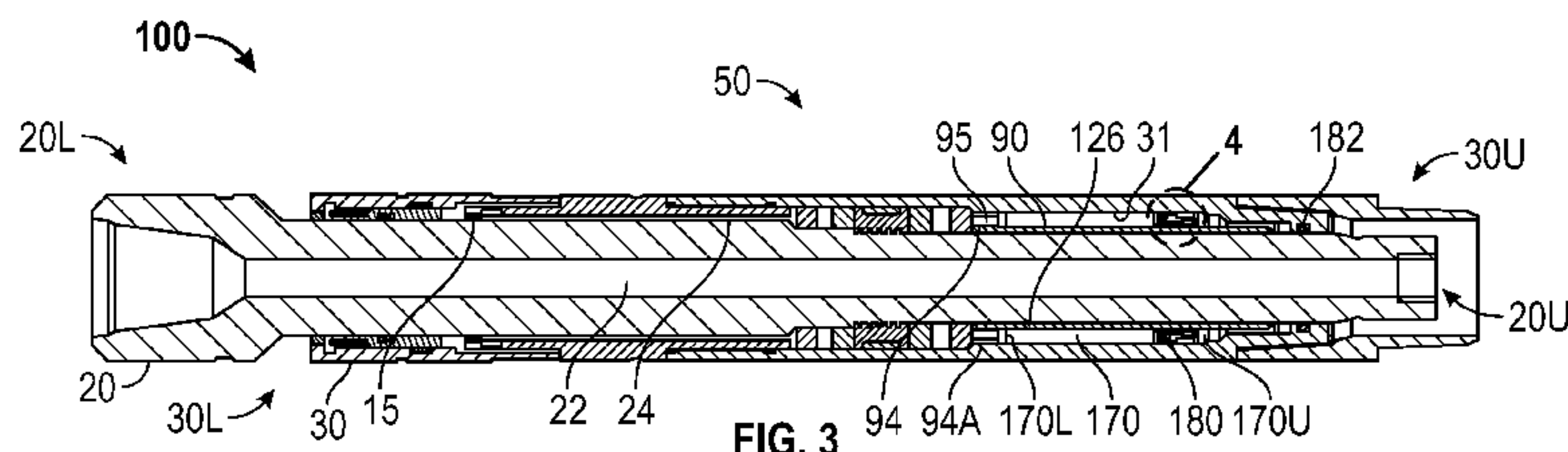

FIG. 3

(57) **Abstract:** In an oil-sealed bearing assembly in the bearing section of a mud motor, in which a mandrel is rotatably disposed within a cylindrical housing, a cylindrical sleeve is disposed coaxially and rotatably around the mandrel, with the sleeve being non-rotatably mounted to an inner surface of the housing, thereby forming an annular piston chamber forming part of a generally annular oil reservoir. The sleeve provides radial support to the mandrel along the length of the piston chamber by virtue of the flexural stiffness of the sleeve. The mandrel rotates within the sleeve, with a radial bearing being provided between the sleeve and the mandrel. An annular piston is axially movable within the piston chamber in response to variations in the volume of oil in the reservoir. The piston slides within the piston chamber without rotation relative to either the housing or the sleeve.



WO 2012/094460 A2

PRESSURE COMPENSATION SYSTEM FOR AN OIL-SEALED MUD MOTOR BEARING ASSEMBLY

[0001] Not applicable.

BACKGROUND

Field of the Invention

[0002] The invention relates generally to bearing assemblies for mud motors used in drilling of oil, gas, and water wells. More particularly, the invention relates to pressure compensation systems for oil-sealed bearing assemblies.

Background of the Technology

[0003] In drilling a wellbore into the earth, such as for the recovery of hydrocarbons or minerals from a subsurface formation, it is conventional practice to connect a drill bit onto the lower end of an assembly of drill pipe sections connected end-to-end (commonly referred to as a “drill string”), and then rotate the drill string so that the drill bit progresses downward into the earth to create the desired wellbore. In conventional vertical wellbore drilling operations, the drill string and bit are rotated by means of either a “rotary table” or a “top drive” associated with a drilling rig erected at the ground surface over the wellbore (or, in offshore drilling operations, on a seabed-supported drilling platform or a suitably adapted floating vessel).

[0004] During the drilling process, a drilling fluid (also commonly referred to in the industry as “drilling mud”, or simply “mud”) is pumped under pressure downward from the surface through the drill string, out the drill bit into the wellbore, and then upward back to the surface through the annular space between the drill string and the wellbore. The drilling fluid, which may be water-based or oil-based, is typically viscous to enhance its ability to carry wellbore cuttings to the surface. The drilling fluid can perform various other valuable functions, including enhancement of drill bit performance (e.g., by ejection of fluid under pressure through ports in the drill bit, creating mud jets that blast into and weaken the underlying formation in advance of the drill bit), drill bit cooling, and formation of a protective cake on the wellbore wall (to stabilize and seal the wellbore wall).

[0005] Particularly since the mid-1980s, it has become increasingly common and desirable in the oil and gas industry to use “directional drilling” techniques to drill horizontal and other non-

vertical wellbores, to facilitate more efficient access to and production from larger regions of subsurface hydrocarbon-bearing formations than would be possible using only vertical wellbores. In directional drilling, specialized drill string components and “bottomhole assemblies” (BHAs) are used to induce, monitor, and control deviations in the path of the drill bit, so as to produce a wellbore of desired non-vertical configuration.

[0006] Directional drilling is typically carried out using a “downhole motor” (alternatively referred to as a “mud motor”) incorporated into the drill string immediately above the drill bit. A typical mud motor includes several primary components, as follows (in order, starting from the top of the motor assembly):

- a top sub adapted to facilitate connection to the lower end of a drill string (“sub” being the common general term in the oil and gas industry for any small or secondary drill string component);
- a power section comprising a positive displacement motor of well-known type, with a helically-vaned rotor eccentrically rotatable within a stator section;
- a drive shaft enclosed within a drive shaft housing, with the upper end of the drive shaft being operably connected to the rotor of the power section; and
- a bearing section comprising a cylindrical mandrel coaxially and rotatably disposed within a cylindrical housing, with an upper end coupled to the lower end of the drive shaft, and a lower end adapted for connection to a drill bit.

The mandrel is rotated by the drive shaft, which rotates in response to the flow of drilling fluid under pressure through the power section. The mandrel rotates relative to the cylindrical housing, which is connected to the drill string.

[0007] In drilling processes using a mud motor, drilling fluid is circulated under pressure through the drill string and back up to the surface as in conventional drilling methods. However, the pressurized drilling fluid exiting the lower end of the drill pipe is diverted through the power section of the mud motor to generate power to rotate the drill bit.

[0008] The bearing section must permit relative rotation between the mandrel and the housing, while also transferring axial thrust loads between the mandrel and the housing. Axial thrust loads arise in two drilling operational modes: “on-bottom” loading, and “off-bottom” loading. On-bottom loading corresponds to the operational mode during which the drill bit is boring into a subsurface formation under vertical load from the weight of the drill string, which in turn is in compression; in other words, the drill bit is on the bottom of the wellbore. Off-bottom loading

corresponds to operational modes during which the drill bit is raised off the bottom of the wellbore and the drill string is in tension (i.e., when the bit is off the bottom of the wellbore and is hanging from the drill string, such as when the drill string is being “tripped” out of the wellbore, or when the wellbore is being reamed in the uphole direction). This condition occurs, for instance, when the drill string is being pulled out of the wellbore, putting the drill string into tension due to the weight of drill string components. Tension loads across the bearing section housing and mandrel are also induced when circulating drilling fluid with the drill bit off bottom, due to the pressure drop across the drill bit and bearing assembly

[0009] Accordingly, the bearing section of a mud motor must be capable of withstanding thrust loads in both axial directions, with the mandrel rotating inside the housing. A mud motor bearing section may be configured with one or more bearings that resist on-bottom thrust loads only, with another one or more bearings that resist off-bottom thrust loads only. Alternatively, one or more bi-directional thrust bearings may be used to resist both on-bottom and off-bottom loads. A typical thrust bearing assembly comprises bearings (usually but not necessarily roller bearings contained within a bearing cage) disposed within an annular bearing containment chamber.

[0010] Bearings contained in the bearing section of a mud motor may be either oil-lubricated or mud-lubricated. In an oil-sealed bearing assembly, the bearings are located within an oil-filled reservoir in an annular region between the mandrel and the housing, with the reservoir being defined by the inner surfaces of the housing and the outer surface of the mandrel, and by sealing elements at each end of the reservoir. Because of the relative rotation between the mandrel and the housing, these sealing elements must include rotary seals.

[0011] Mud motor bearing sections also include multiple radial bearings to maintain coaxial alignment between the mandrel and the bearing housing. In an oil-sealed assembly, the radial bearings can be provided in the form of bushings disposed in an annular space between the inner surface of the housing and the outer surface of the mandrel. It is desirable to maximize radial support for the mandrel in order to maximize the mandrel's resistance to flexural stresses induced when drilling non-straight wellbores.

[0012] An oil-sealed bearing assembly must incorporate pressure compensation means, whereby the volume of the annular oil reservoir is automatically adjusted to compensate for changes in oil volume due to temperature changes. In addition, certain types of elastomeric rotary seals (such as KALSI SEALS[®]) are designed to slowly pump oil underneath the seal interface, and this causes a gradual reduction in oil volume which also must be compensated

for. For optimum performance of the rotary seal, it is ideal for the sealing surface of the mandrel to be as wear-resistant as possible, while having a very fine surface finish.

[0013] A common method of providing pressure compensation in an oil-sealed bearing assembly uses an annularly-configured piston disposed within an annular region (or “piston chamber”) between the housing and mandrel. The outer diameter (O.D.) of the piston is sealed against the inner bore of the housing (by means of one or more sliding seals, such as O-rings), and also may incorporate anti-rotation seals to ensure that the piston does not rotate relative to the housing. The inner diameter (I.D.) of the piston is sealed against the mandrel by means of a rotary seal, which rotates relative to the mandrel during operation, and also slides axially along the mandrel as the piston moves. The rotary seal and sliding seals associated with the piston thus define the upper end of the oil reservoir within the bearing assembly.

[0014] A sufficient length of the mandrel below the piston’s initial position must remain uninterrupted to accommodate the piston travel that will occur as oil volume varies over time (whether due to temperature change or oil loss). The housing bore must be similarly uninterrupted along this length, forming a cylindrical oil reservoir. The uppermost radial support is thus located at a point below the oil reservoir. Therefore, a significant length of the mandrel in a conventional oil-sealed mud motor bearing section is not radially supported.

[0015] Alternatively, radial support for the mandrel may be provided to some extent by the pressure-compensating piston itself. However, the length of radial support is limited to the length of the piston (which desirably should be minimized), and the mandrel will still be unsupported along the length of the oil reservoir (said length of which will be greatest when the oil reservoir is full and the piston is at its uppermost position).

[0016] For optimum performance of the rotary seal, it is ideal for the sealing surface of the mandrel to be as wear-resistant as possible, with a very fine surface finish. This is typically provided through the use of a surface treatment such as an abrasion-resistant, diamond-ground coating. To accommodate axial translation of the piston within the piston chamber, the surface treatment of the mandrel needs to be provided over a length corresponding to at least the range of travel of the piston’s rotary seal, and preferably the full length of the piston chamber.

[0017] Accordingly, there remains a need in the art for a pressure compensation system for oil-sealed mud motor bearing assemblies that provides radial support for the portion of the mandrel corresponding to the stroke of the pressure-compensating piston. Embodiments disclosed herein are directed to these needs.

BRIEF SUMMARY OF THE DISCLOSURE

[0018] In accordance with at least one embodiment disclosed herein, a cylindrical sleeve is mounted, internally and coaxially, within the cylindrical housing of an oil-sealed bearing assembly in a mud motor, such that the sleeve is non-rotatable relative to the housing, and such that a cylindrical chamber is formed between the O.D. of the sleeve and the I.D. of the housing. The mandrel of the bearing assembly rotates coaxially within the sleeve, with suitable bearing means (such as a bushing) disposed between the I.D. of the sleeve and the O.D. of the mandrel. The sleeve effectively provides radial support to the corresponding length of the mandrel by virtue of the sleeve's flexural stiffness, such that flexural stresses induced in the mandrel during well-drilling operations will be less than they would be in a bearing assembly not having the radial support sleeve.

[0019] The above-noted cylindrical chamber between the O.D. of the radial support sleeve and the I.D. of the housing forms part of a generally annular oil reservoir in which one or more oil-lubricated thrust bearings are disposed. An annularly-configured pressure-balancing piston is disposed within the cylindrical chamber, and is axially movable within the chamber in response to variations in the volume of oil in oil reservoir. Because the radial support sleeve is non-rotating relative to the housing, the piston simply slides within the cylindrical chamber, and therefore can use simple sliding seals rather than rotary seals, which are generally more costly and susceptible to wear than non-rotary seals. As well, there is no need to provide the piston with anti-rotation seals, thus considerably reducing the seal friction that must be overcome as the piston translates during compensation. Accordingly, in addition to providing radial support for the mandrel along the length of the cylindrical chamber (unlike in conventional oil-sealed bearing assemblies), the radial support sleeve provides the significant further benefit of eliminating the need for rotary seals in the pressure-balancing piston. Instead, the upper rotary seal for the oil reservoir is housed in a fixed location within the housing rather than being associated with the piston, such that it does not translate during operation. Therefore, the length of the mandrel requiring wear-resistant surface treatment for the rotary seal can be kept to a minimum, resulting in significant cost savings.

[0020] Accordingly, at least one embodiment disclosed herein teaches an oil pressure compensation system for a mud motor bearing section, where the pressure compensation system comprises:

- a cylindrical sleeve coaxially and rotatably disposable around an outer cylindrical surface of the mandrel of the bearing section in a region above the bearing chamber,

in conjunction with a radial bearing disposed between the inner surface of the sleeve and the outer cylindrical surface of the mandrel, with the sleeve being non-rotatably connectable to the housing to form a cylindrical piston chamber between the outer surface of the sleeve and an inner surface of the housing; and

- an annularly-configured piston disposable within the piston chamber, such that the piston is axially and non-rotatingly movable within the piston chamber, with the inner and outer faces of the piston sealingly engageable, respectively, with the outer surface of the sleeve and the inner surface of the housing.

[0021] In another aspect, at least one embodiment disclosed herein teaches a bearing section for a mud motor, where the bearing section comprises:

- an elongate mandrel rotatably and coaxially disposed within an elongate cylindrical housing, with the mandrel having an outer surface, and the housing having an inner surface;
- an annular oil reservoir bounded by the outer surface of the mandrel and the inner surface of the housing, and extending between upper and lower rotary seals between the mandrel and the housing, a portion of said oil reservoir defining an annular bearing chamber;
- a cylindrical sleeve having inner and outer cylindrical surfaces, with the sleeve being coaxially and rotatably disposed around an outer cylindrical surface of the mandrel in a region above the bearing chamber, in conjunction with a radial bearing disposed between the inner surface of the sleeve and the outer cylindrical surface of the mandrel, with the sleeve being non-rotatably mounted to the housing to form a cylindrical piston chamber between the outer surface of the sleeve and an inner surface of the housing; and
- an annularly-configured piston disposed within the piston chamber, with the piston being axially and non-rotatingly movable within the piston chamber, and with the piston having inner and outer faces sealingly engageable, respectively, with the outer surface of the sleeve and the inner surface of the housing.

[0022] In a further aspect, at least one embodiment disclosed herein teaches a method of providing increased radial support for a mandrel rotatable within the cylindrical housing of a mud motor bearing section having a bearing chamber, where the method comprises the steps of:

- providing a cylindrical sleeve having inner and outer cylindrical surfaces; and

- mounting the sleeve coaxially and rotatably around an outer cylindrical surface of the mandrel in a region above the bearing chamber, in conjunction with a radial bearing disposed between the cylindrical inner surface of the sleeve and an outer cylindrical surface of the mandrel, and with the sleeve being non-rotatable relative to the housing.

[0023] Thus, embodiments described herein comprise a combination of features and advantages intended to address various shortcomings associated with certain prior devices, systems, and methods. The various characteristics described above, as well as other features, will be readily apparent to those skilled in the art upon reading the following detailed description, and by referring to the accompanying drawings.

BRIEF DESCRIPTION OF THE DRAWINGS

[0024] For a detailed description of the preferred embodiments of the invention, reference will now be made to the accompanying drawings, in which numerical references denote like parts, and in which:

[0025] FIGURE 1 is a longitudinal cross-section through the bearing section of a prior art mud motor.

[0026] FIGURE 2 is an enlarged detail of the pressure-compensating piston of the prior art bearing section shown in FIG. 1.

[0027] FIGURE 3 is a longitudinal cross-section through the bearing section of a mud motor incorporating pressure compensation means in accordance with an embodiment of the present invention.

[0028] FIGURE 4 is an enlarged detail of the pressure-compensating piston of the bearing section shown in FIG. 3.

DETAILED DESCRIPTION OF SOME OF THE PREFERRED EMBODIMENTS

[0029] The following discussion is directed to various embodiments of the invention. Although one or more of these embodiments may be preferred, the embodiments disclosed should not be interpreted, or otherwise used, as limiting the scope of the disclosure, including the claims. In addition, one skilled in the art will understand that the following description has broad application, and the discussion of any embodiment is meant only to be exemplary of that embodiment, and not intended to intimate that the scope of the disclosure, including the claims, is limited to that embodiment.

[0030] Certain terms are used throughout the following description and claims to refer to particular features or components. As one skilled in the art will appreciate, different persons may refer to the same feature or component by different names. This document does not intend to distinguish between components or features that differ in name but not function. The drawing figures are not necessarily to scale. Certain features and components herein may be shown exaggerated in scale or in somewhat schematic form and some details of conventional elements may not be shown in interest of clarity and conciseness.

[0031] In the following discussion and in the claims, the terms "including" and "comprising" are used in an open-ended fashion, and thus should be interpreted to mean "including, but not limited to... ." Also, the term "couple" or "couples" is intended to mean either an indirect or direct connection. Thus, if a first device couples to a second device, that connection may be through a direct connection, or through an indirect connection via other devices, components, and connections. In addition, as used herein, the terms "axial" and "axially" generally mean along or parallel to a central axis (e.g., central axis of a body or a port), while the terms "radial" and "radially" generally mean perpendicular to the central axis. For instance, an axial distance refers to a distance measured along or parallel to the central axis, and a radial distance means a distance measured perpendicular to the central axis.

[0032] Any use of any form of the terms "connect", "mount", "engage", "couple", "attach", or any other term describing an interaction between elements is not meant to limit the interaction to direct interaction between the subject elements, and may also include indirect interaction between the elements such as through secondary or intermediary structure. Relational terms such as "parallel", "perpendicular", "coincident", "intersecting", and "equidistant" are not intended to denote or require absolute mathematical or geometrical precision. Accordingly, such terms are to be understood as denoting or requiring substantial precision only (e.g., "substantially parallel") unless the context clearly requires otherwise.

[0033] FIG. 1 illustrates a typical oil-sealed bearing assembly in the bearing section **10** of a prior art mud motor, and FIG. 2 illustrates the pressure-compensating piston **80** of the prior art assembly. Bearing section **10** includes a mandrel **20** having an upper end **20U**, a lower end **20L**, and a central bore **22** through which drilling fluid can be pumped down to a drill bit (not shown) connected directly or indirectly to lower end **20L** of mandrel **20**. Mandrel **20** is coaxially and rotatably disposed within a cylindrical housing **30**, which typically will be made up of multiple subsections (such as **30A**, **30B**, **30C**, **30D** in FIG. 1) threaded together. Housing **30** has a first or upper end **30U** adapted for connection to the lower end of the drive shaft

housing (not shown) of the mud motor, and a second or lower end **30L** (through which lower end **20L** of mandrel **20** projects). Upper end **20U** of mandrel **20** is adapted for connection to the drive shaft (not shown) of the mud motor, such that the drive shaft will rotate mandrel **20** within and relative to housing **30**. In the illustrated assembly, a lower rotary seal **15** is provided between mandrel **20** and housing **30** near the lower end of subsection **30C** of housing **30**.

[0034] In the illustrated prior art bearing section **10**, a bearing assembly **50** is disposed within an annular bearing chamber between mandrel **20** and housing **30**, at roughly mid-length of bearing section **10**. For illustration purposes, bearing assembly **50** is shown as comprising a lower bearing **52** (with associated bearing races) for resisting off-bottom thrust loads; an upper bearing **54** (with associated bearing races) for resisting on-bottom thrust loads; and a split ring **56** mounted to mandrel **20** to provide load-transferring shoulders for transferring thrust loads to bearings **52** and **54**. However, the structural and operational details of bearing assembly **50** are not directly relevant to embodiments of the present invention, and therefore are not described in further detail in this patent specification. Between bearing assembly **50** and lower end **30L** of housing **30**, a lower radial bearing (shown in the form of a lower bushing **24**) is provided in an annular space between mandrel **20** and housing **30**, to provide radial support to mandrel **20** as it rotates within housing **30**.

[0035] Referring now to FIGS. 1 and 2, in a region above bearing assembly **50**, a cylindrical piston chamber **70** is formed between the outer cylindrical surface **21** of mandrel **20** and the inner cylindrical surface **31** of housing **30**. An annular piston **80** is disposed within cylindrical piston chamber **70**, and is axially and bi-directionally movable therein. Piston **80** typically is non-rotatable relative to housing **30**, while upper end **20U** of mandrel **20** rotates relative to piston **80** and housing **30**. Accordingly, piston **80** carries a rotary seal **82** to seal piston **80** relative to mandrel **20** as piston **80** moves axially within cylindrical piston chamber **70** and as mandrel **20** rotates within and relative to piston **80**. The upper end of piston **80** also carries a wiper seal **85** which engages outer surface **21** of mandrel **20**. Piston **80** is also shown with a bushing **84** engaging outer surface **21** of mandrel **20**, and multiple sliding seals **83** engaging inner surface **31** of housing **30**. Optionally, piston **80** may also have an outer bushing **86** engaging inner surface **31** of housing **30**, as shown in FIG. 2. A generally annular oil reservoir is thus formed between lower rotary seal **15**, piston **80** (with its associated seals), outer surface **21** of mandrel **20**, and inner surface **31** of housing **30**, and includes piston chamber **70** and the bearing chamber associated with bearing assembly **50**. As seen in FIG. 2, piston **80** may have one or more oil channels **87** and mud channels **88** for distributing oil and drilling mud

(respectively) between the inner and outer surfaces of piston **80**, to prevent hydraulic pressure locking between pairs of seals.

[0036] Piston chamber **70** has an upper end **70U** and a lower end **70L**, defining a piston travel length L_{PT} through which piston **80** can travel. An upper radial bearing (shown in the form of an upper bushing **26**) is provided in an annular space between mandrel **20** and housing **30** in a region between bearing assembly **50** and lower end **70L** of piston chamber **70**. However, a portion of mandrel **20** having a length corresponding to piston travel length L_{PT} has no radial support (except to the variable extent of any radial support provided by piston **80**).

[0037] FIGS. 3 and 4 illustrate a mud motor bearing section **100** incorporating a pressure compensation system in accordance with an embodiment of the present invention. Bearing section **100** includes a mandrel **20**, a housing **30**, and a lower rotary seal **15**, generally as described and illustrated with reference to prior art bearing section **10** in FIG. 1. Bearing section **100** incorporates a bearing assembly **50** disposed within an annular bearing chamber between mandrel **20** and housing **30**, at roughly mid-length of bearing section **100**. Bearing assembly **50** is shown as being identical to bearing assembly **50** in FIG. 1, but could be of a different configuration in other embodiments. As in prior art bearing section **10**, a lower bushing **24** is provided in the annular space between mandrel **20** and housing **30** between bearing assembly **50** and lower end **30L** of housing **30**, to provide radial support to mandrel **20** as it rotates within housing **30**. An upper rotary seal **182** is located within housing **30** (toward upper end **30U** thereof) to seal housing **30** relative to mandrel **20** as mandrel **20** rotates within and relative to housing **30**.

[0038] At a point above (and preferably directly above) bearing assembly **50**, a cylindrical sleeve **90** is mounted inside, and coaxial with housing **30**, such that sleeve **90** is non-rotatable relative to the housing, and such that an annular piston chamber **170** (with upper end **170U** and lower end **170L**) is formed between the outer cylindrical surface **91** of sleeve **90** and the inner cylindrical surface **31** of housing **30**. In general, sleeve **90** may be non-rotatably mounted to housing **30** in any suitable way known in the art. By way of non-limiting example, this is achieved in the embodiment shown in FIG. 3 by providing the lower end of sleeve **90** with a circular flange **94**, projecting radially outward from outer cylindrical surface **91**, to facilitate mounting to housing **30**, such as by means of a threaded connection represented in FIG. 3 by reference number **94A**. One or more oil passages **95** extend axially through flange **94** to allow the flow of oil between piston chamber **170** and bearing assembly **50**.

[0039] The upper end **96** of sleeve **90** is anchored to housing **30** by any suitably secure means (such as but not limited to friction due to makeup torque applied to threaded connection **94A**). An upper bushing **126** is provided in an annular space between the outer cylindrical surface **21** of mandrel **20** and the inner cylindrical surface **92** of sleeve **90**, the bushing directly engaging surface **92** and surface **21**. This facilitates rotation of mandrel **20** within sleeve **90** (optionally with lubrication channels **28** provided in the inner cylindrical surface **92** of sleeve **90** to allow passage of oil to lubricate bushing **126** and upper rotary seal **182**).

[0040] An annular pressure-balancing piston **180** is disposed within piston chamber **170**, and is axially and bi-directionally movable therein. Piston **180** has an outer face **180A** for sliding engagement with inner surface **31** of housing **30** in conjunction with an outer seal **93A**, and an inner face **180B** for sliding engagement with outer surface **91** of sleeve **90** in conjunction with an inner seal **93B**. Since sleeve **90** is non-rotatable relative to housing **30**, piston **180** does not rotate relative to both housing **30** and sleeve **90**. Accordingly, outer seal **93A** and inner seal **93B** can be sliding seals (such as O-rings or lip seals) rather than rotary seals.

[0041] A generally annular oil reservoir is thus formed between lower rotary seal **15**, upper rotary seal **182**, piston **90** (with sliding seals **93A** and **93B**), outer surface **91** of sleeve **90**, outer surface **21** of mandrel **20**, and inner surface **31** of housing **30**, and includes piston chamber **170** and the bearing chamber associated with bearing assembly **50**. Piston **180** is also shown with an optional bushing **184** engaging outer surface **91** of sleeve **90** and an optional bushing **186** engaging inner surface **31** of housing **30**.

[0042] Sleeve **90** effectively provides radial support to the corresponding length of mandrel **20** by virtue of the flexural stiffness of sleeve **90**. Furthermore, since piston **180** does not rotate relative to either housing **30** or sleeve **90**, rotary seals and anti-rotation seals within piston **180** are unnecessary. Whereas the upper rotary seal **82** in the prior art assembly of FIGS. 1 and 2 translates along mandrel **20** during operation of piston **80**, upper rotary seal **182** of the assembly in FIGS. 3 and 4 is housed in a fixed location within housing **30**, such that it does not translate during operation of piston **180**. Therefore, the length of outer surface **21** of mandrel **20** requiring wear-resistant surface treatment for rotary seal **182** can be kept to a minimum, with resultant cost savings. In addition, and unlike in prior art piston **80** in FIG. 2, piston **180** can use a single upper seal and a single lower seal as shown in FIG. 3, so hydraulic pressure locking is not an issue and it is unnecessary for piston **180** to have to oil channels **87** and mud channels **88** as in piston **80**.

[0043] While preferred embodiments have been shown and described, modifications thereof can be made by one skilled in the art without departing from the scope or teachings herein. The embodiments described herein are exemplary only and are not limiting. Many variations and modifications of the systems, apparatus, and processes described herein are possible and are within the scope of the invention. For example, the relative dimensions of various parts, the materials from which the various parts are made, and other parameters can be varied. Accordingly, the scope of protection is not limited to the embodiments described herein, but is only limited by the claims that follow, the scope of which shall include all equivalents of the subject matter of the claims.

**THE EMBODIMENTS OF THE INVENTION IN WHICH AN EXCLUSIVE
PROPERTY OR PRIVILEGE IS CLAIMED ARE DEFINED AS FOLLOWS:**

1. A mud motor bearing section having an upper end and a lower end, said bearing
5 section comprising:
- (a) an elongate mandrel rotatably and coaxially disposed within an elongate
cylindrical housing having a longitudinal axis, said mandrel having an
outer surface, and said housing having an inner surface;
 - (b) an annular oil reservoir radially disposed between the outer surface of the
10 mandrel and the inner surface of the housing, and extending axially
between an upper rotary seal and a lower rotary seal, wherein both the
upper rotary seal and the lower rotary seal are radially disposed between
the mandrel and the housing, and wherein a portion of the oil reservoir
defines an annular bearing chamber;
 - (c) an oil pressure compensation system comprising:
 - a cylindrical sleeve having an inner cylindrical surface and an outer
cylindrical surface, wherein the sleeve is coaxially disposed about an
outer cylindrical surface of the mandrel in a region axially above the
bearing chamber and is non-rotatably coupled to the housing to form
20 an annular piston chamber between the outer cylindrical surface of the
sleeve and an inner cylindrical surface of the housing, and wherein the
mandrel is configured to rotate relative to the sleeve;
 - an annular flange disposed at a lower end of the sleeve coupling the
sleeve to the housing, wherein the annular flange includes an oil
25 passage configured to allow oil to pass therethrough;
 - a radial bearing disposed between and directly engaging the inner
cylindrical surface of the sleeve and the outer cylindrical surface of
the mandrel; and

an annular piston non-rotatingly disposed within the piston chamber, wherein the piston is adapted to move axially within the piston chamber, and wherein the piston has an inner face sealingly engaging the outer cylindrical surface of the sleeve, and an outer face sealingly engaging the inner cylindrical surface of the housing.

5

2. The mud motor bearing section of Claim 1, wherein the inner face of the piston carries a non-rotary seal for sealing engagement with the outer cylindrical surface of the sleeve.
3. The mud motor bearing section of Claim 1 or Claim 2, wherein the outer face of the piston carries a non-rotary seal for sealing engagement with the inner surface of the housing.
4. The mud motor bearing section of any one of Claims 1-3, wherein the flange extends radially outward from the outer cylindrical surface of the sleeve, said flange being adapted for non-rotatable connection to the housing.
5. The mud motor bearing section of any one of Claims 1-4, wherein the radial bearing comprises a bushing.
6. The mud motor bearing section of Claim 5, wherein one or more lubrication channels are formed in the inner cylindrical surface of the sleeve.
7. The mud motor bearing section of any one of Claims 1-6, wherein a bushing is provided in association with the inner face of the piston.
8. The mud motor bearing section of any one of Claims 1-7, wherein a bushing is provided in association with the outer face of the piston.

10

15

20

9. A bearing section for a mud motor, said bearing section comprising:
- 5 (a) an elongate mandrel rotatably and coaxially disposed within an elongate cylindrical housing having a longitudinal axis, wherein the mandrel has an outer surface, and wherein the housing has a first end, a second end, and an inner surface extending axially between the first end and the second end;
- 10 (b) an annular oil reservoir bounded by the outer surface of the mandrel and the inner surface of the housing, and extending axially between an upper rotary seal and a lower rotary seal, wherein both the upper rotary seal and the lower rotary seal are disposed between the mandrel and the housing, and wherein a portion of the oil reservoir defines an annular bearing chamber;
- 15 (c) a cylindrical sleeve having an inner cylindrical surface and an outer cylindrical surface, wherein the sleeve is coaxially disposed around an outer cylindrical surface of the mandrel in a region completely above the bearing chamber, with the sleeve being non-rotatably mounted to the housing to form an annular piston chamber between the outer cylindrical surface of the sleeve and an inner cylindrical surface of the housing, and wherein the mandrel is configured to rotate relative to the sleeve;
- 20 (d) a radial bearing disposed between and directly engaging the inner cylindrical surface of the sleeve and the outer cylindrical surface of the mandrel; and
- 25 (e) an annularly-configured piston disposed within the piston chamber, wherein the piston is axially and non-rotatingly movable within the piston chamber, and wherein the piston has an inner face sealingly engageable with the outer cylindrical surface of the sleeve, and an outer face sealingly engageable with the inner cylindrical surface of the housing.

10. The bearing section of Claim 9, wherein the inner face of the piston sealingly engages the outer cylindrical surface of the sleeve by means of a non-rotary seal.
11. The bearing section of Claim 9 or Claim 10, wherein the outer face of the piston sealingly engages the inner cylindrical surface of the housing by means of a non-rotary seal.
12. The bearing section of any one of Claims 9-11, wherein the sleeve has a circular flange projecting radially outward from the sleeve's outer cylindrical surface, said sleeve being non-rotatably connected to the housing.
13. The bearing section of any one of Claims 9-12, wherein the radial bearing comprises a bushing.
14. The bearing section of Claim 13, wherein one or more lubrication channels are formed in the inner cylindrical surface of the sleeve.
15. The bearing section of any one of Claims 9-14, wherein a bushing is provided in association with the inner face of the piston.
16. The bearing section of any one of Claims 9-15, wherein a bushing is provided in association with the outer face of the piston.
17. A method of providing increased radial support for an elongate mandrel in association with an elongate mud motor bearing section, said mandrel having an outer surface and being rotatably and coaxially disposed within an elongate cylindrical housing having an inner surface, said method comprising the steps of:
- (a) providing a cylindrical sleeve having an upper end, a lower end, an inner cylindrical surface, and an outer cylindrical surface;
 - (b) mounting the sleeve coaxially around the outer cylindrical surface of the mandrel in a region between an annular bearing chamber and an upper

rotary seal, wherein the bearing chamber is formed in an annular oil reservoir bounded by the outer surface of the mandrel and the inner surface of the housing and extending between the upper rotary seal and a lower rotary seal between the mandrel and the housing, wherein the sleeve is non-rotatable relative to the housing, and wherein the mandrel is rotatable relative to the sleeve;

5

(c) coupling the sleeve to the housing with an annular flange disposed at the lower end of the sleeve, wherein the flange includes an oil passage; and

(d) providing a radial bearing disposed between and directly engaging the inner cylindrical surface of the sleeve and the outer cylindrical surface of the mandrel.

10

18. The method of Claim 17 wherein the radial bearing comprises a bushing.

19. The method of Claim 18 wherein one or more lubrication channels are formed in the inner cylindrical surface of the sleeve.

15

20. The method of any one of Claims 17-19 wherein:

(a) a cylindrical piston chamber is formed between the outer cylindrical surface of the sleeve and an inner cylindrical surface of the housing; and

(b) the method further comprises the step of providing pressure compensation means comprising an annularly-configured piston disposed within and axially movable within the piston chamber, said piston having an inner face sealingly engageable with the outer cylindrical surface of the sleeve, and an outer face sealingly engageable with the inner cylindrical surface of the housing.

20

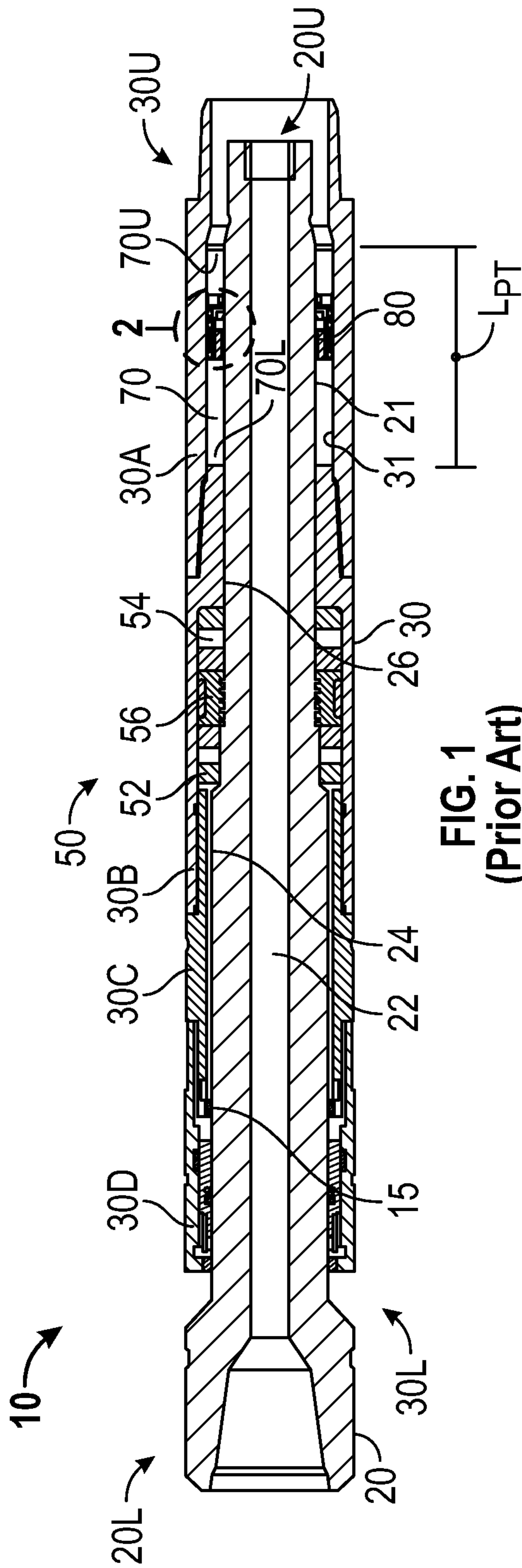

FIG. 1
(Prior Art)

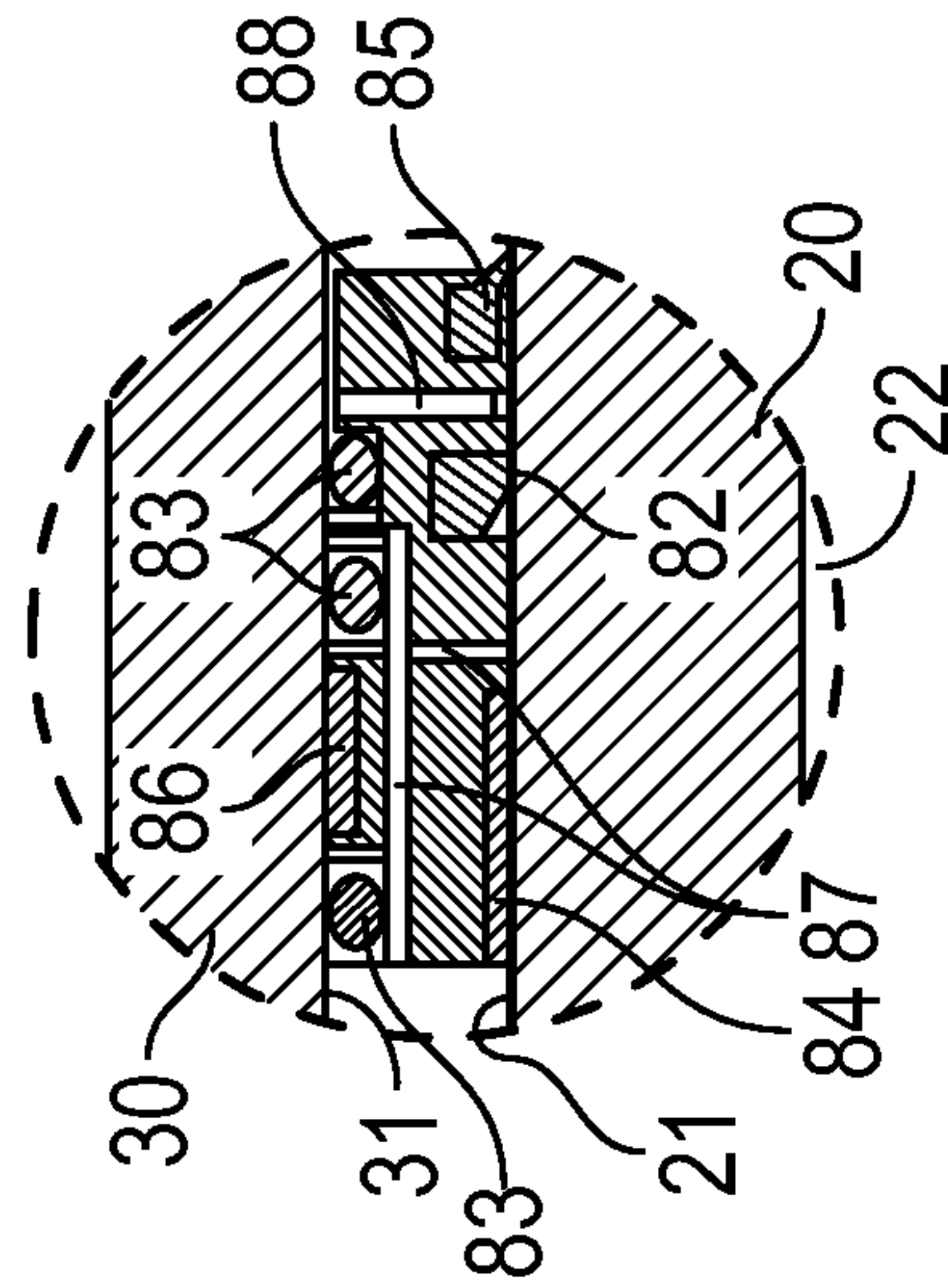

FIG. 2
(Prior Art)

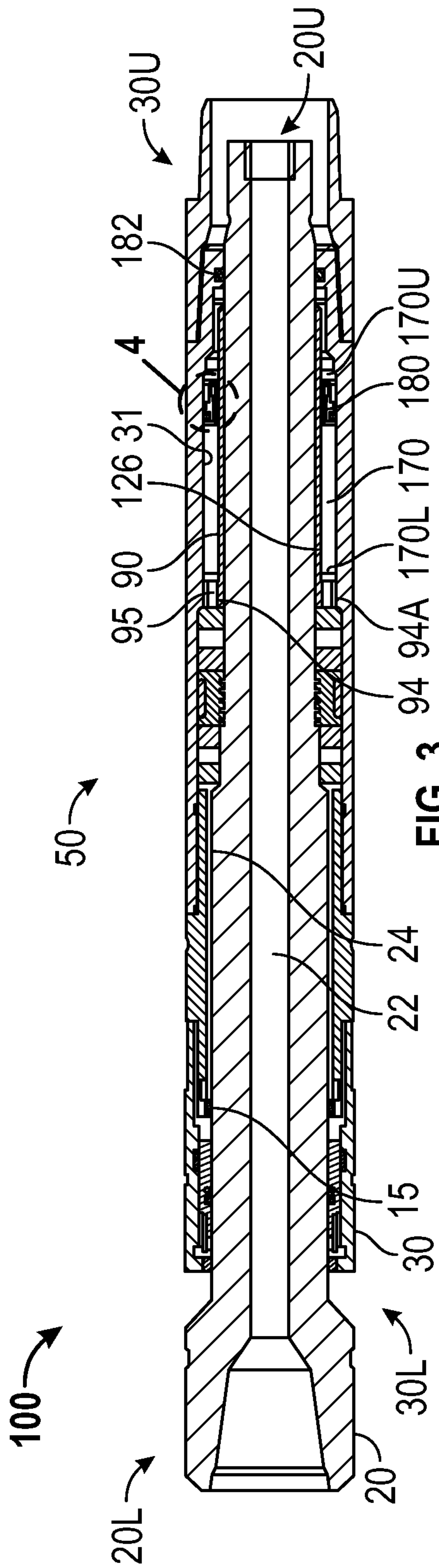

FIG. 3

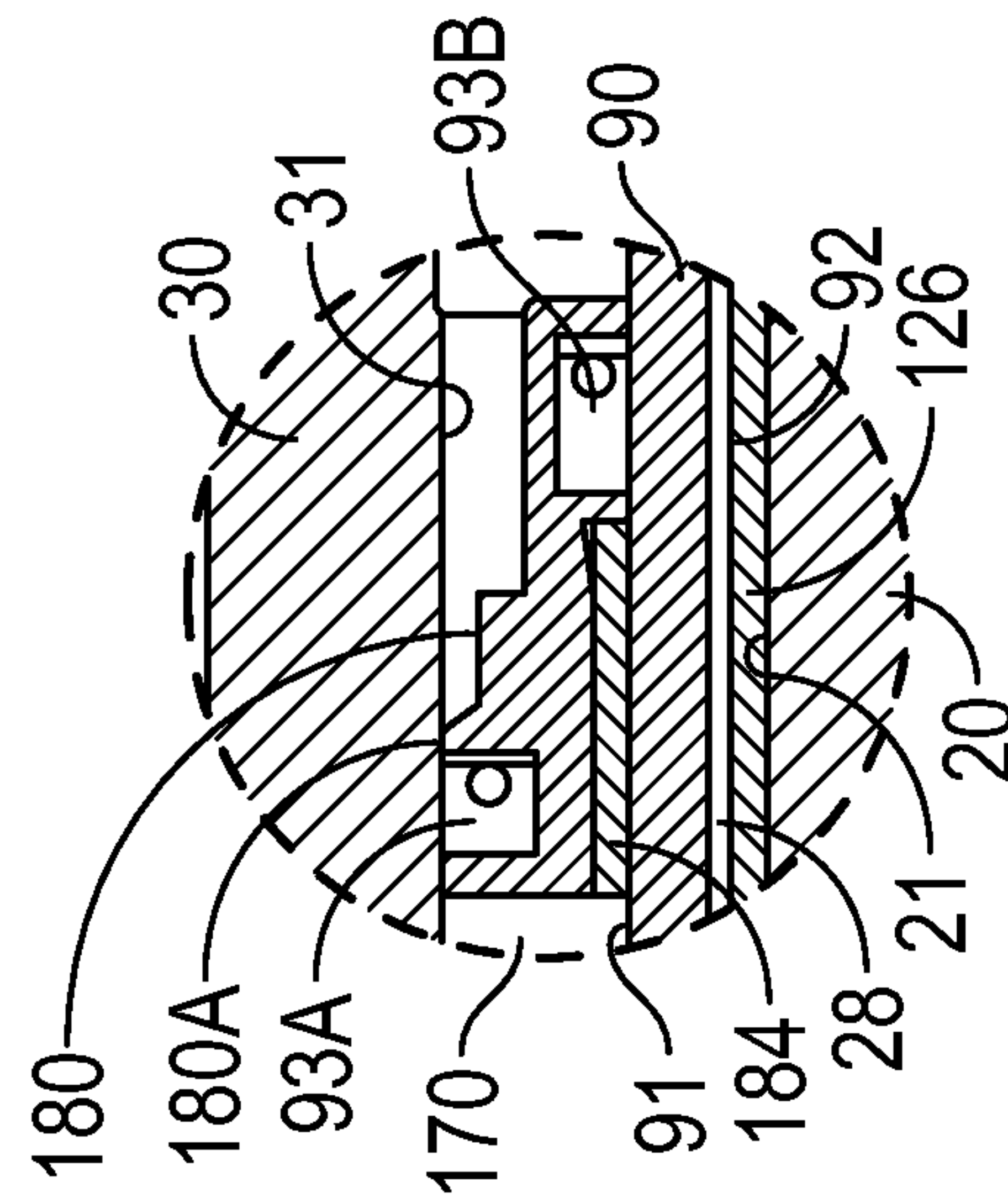

FIG. 4

